

BID OF \_\_\_\_\_

**2017**

**PROPOSAL, CONTRACT, BOND AND SPECIFICATIONS**

**FOR**

**BLACKHAWK WATER TOWER**

**CONTRACT NO. 7821**

**PROJECT NO. 10445**

**MUNIS NO. 10445-86-140**

**IN**

**MADISON, DANE COUNTY, WISCONSIN**

AWARDED BY THE COMMON COUNCIL  
MADISON, WISCONSIN ON \_\_\_\_\_

CITY ENGINEERING DIVISION  
1600 EMIL STREET  
MADISON, WISCONSIN 53713

<https://bidexpress.com/login>

**BLACKHAWK WATER TOWER  
CONTRACT NO. 7821**

**INDEX**

SECTION A: ADVERTISEMENT FOR BIDS AND INSTRUCTIONS TO BIDDERS ..... A-1  
SECTION B: PROPOSAL SECTION ..... B-1  
SECTION C: SMALL BUSINESS ENTERPRISE ..... C-1  
SECTION D: SPECIAL PROVISIONS ..... D-1  
SECTION E: BIDDER'S ACKNOWLEDGEMENT ..... E-1  
SECTION F: BEST VALUE CONTRACTING ..... F-1  
SECTION G: BID BOND ..... G-1  
SECTION H: AGREEMENT ..... H-1  
SECTION I: PAYMENT AND PERFORMANCE BOND ..... I-1

This Proposal, and Agreement have  
been prepared by:

**CITY ENGINEERING DIVISION  
CITY OF MADISON  
MADISON, DANE COUNTY, WISCONSIN**

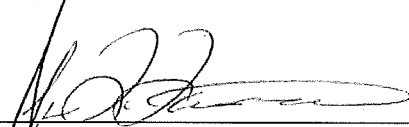

Alan Larson, P.E., B.C.E.E  
Water Utility Principal Engineer

PEH:



## SECTION A: ADVERTISEMENT FOR BIDS AND INSTRUCTIONS TO BIDDERS

### REQUEST FOR BID FOR PUBLIC WORKS CONSTRUCTION CITY OF MADISON, WISCONSIN

#### A BEST VALUE CONTRACTING MUNICIPALITY

PROJECT NAME:	BLACKHAWK WATER TOWER
CONTRACT NO.:	7821
SBE GOAL	2%
BID BOND	5%
PRE BID MEETING (1:00 P.M.)	1/20/2017
PREQUALIFICATION APPLICATION DUE (1:00 P.M)	1/20/2017
BID SUBMISSION (1:00 P.M.)	1/27/2017
BID OPEN (1:30 P.M.)	1/27/2017
PUBLISHED IN WSJ	1/6/2017, 1/13/2017 & 1/20/2017

PRE BID MEETING: Representatives of the Affirmative Action Department will be present to discuss the Small Business Enterprise requirements at 1600 Emil Street, Madison Wisconsin.

PREQUALIFICATION APPLICATION: Forms are available on our website, [www.cityofmadison.com/business/pw/forms.cfm](http://www.cityofmadison.com/business/pw/forms.cfm). If not currently prequalified in the categories listed in Section A, an amendment to your Prequalification will need to be submitted prior to the same due date. Postmark is not applicable.

BIDS TO BE SUBMITTED by hand to 1600 EMIL ST., MADISON, WI 53713 or online at [www.bidexpress.com](http://www.bidexpress.com).

THE BID OPENING is at 1600 EMIL ST., MADISON, WI 53713.

#### STANDARD SPECIFICATIONS

The City of Madison's Standard Specifications for Public Works Construction - 2016 Edition, as supplemented and amended from time to time, forms a part of these contract documents as if attached hereto.

These standard specifications are available on the City of Madison Public Works website, [www.cityofmadison.com/Business/PW/specs.cfm](http://www.cityofmadison.com/Business/PW/specs.cfm).

The Contractor shall review these Specifications prior to preparation of proposals for the work to be done under this contract, with specific attention to Article 102, "BIDDING REQUIREMENTS AND CONDITIONS" and Article 103, "AWARD AND EXECUTION OF THE CONTRACT." For the convenience of the bidder, below are highlights of three subsections of the specifications.

#### SECTION 102.1: PRE-QUALIFICATION OF BIDDERS

In accordance with Wisconsin State Statutes 66.0901 (2) and (3), all bidders must submit to the Board of Public Works proof of responsibility on forms furnished by the City. The City requires that all bidders be qualified on a biennial basis.

Bidders must present satisfactory evidence that they have been regularly engaged in the type of work specified herein and they are fully prepared with necessary capital, materials, machinery and supervisory personnel to conduct the work to be contracted for to the satisfaction of the City. All bidders must be pre-qualified by the Board of Public Works for the type of construction on which they are bidding prior to the opening of the bid.

In accordance with Section 39.02(9)(a)l. of the General Ordinances, all bidders shall submit in writing to the Affirmative Action Division Manager of the City of Madison, a Certificate of Compliance or an Affirmative Action Plan at the same time or prior to the submission of the proof of responsibility forms.

The bidder shall be disqualified if the bidder fails to or refuses to, prior to opening of the bid, submit a Certificate of compliance, Affirmative Action Plan or Affirmative Action Data Update, as applicable, as defined by Section 39.02 of the General Ordinances (entitled Affirmative Action) and as required by Section 102.11 of the Standard Specifications.

#### SECTION 102.4 PROPOSAL

No bid will be accepted that does not contain an adequate or reasonable price for each and every item named in the Schedule of Unit Prices.

A lump sum bid for the work in accordance with the plans and specifications is required. The lump sum bid must be the same as the total amounts bid for the various items and it shall be inserted in the space provided.

All papers bound with or attached to the proposal form are considered a part thereof and must not be detached or altered when the proposal is submitted. The plans, specifications and other documents designated in the proposal form will be considered a part of the proposal whether attached or not.

A proposal submitted by an individual shall be signed by the bidder or by a duly authorized agent. A proposal submitted by a partnership shall be signed by a member/partner or by a duly authorized agent thereof. A proposal submitted by a corporation shall be signed by an authorized officer or duly authorized registered agent of such corporation, and the proposal shall show the name of the State under the laws of which such corporation was chartered. The required signatures shall in all cases appear in the space provided thereof on the proposal.

Each proposal shall be placed, together with the proposal guaranty, in a sealed envelope, so marked as to indicate name of project, the contract number or option to which it applies, and the name and address of the Contractor or submitted electronically through Bid Express ([www.bidexpress.com](http://www.bidexpress.com)). Proposals will be accepted at the location, the time and the date designated in the advertisement. Proposals received after the time and date designated will be returned to the bidder unopened.

#### SECTION 102.5: BID DEPOSIT (PROPOSAL GUARANTY)

All bids, sealed or electronic, must be accompanied with a Bid Bond equal to at least 5% of the bid or a Certificate of Annual/Biennial Bid Bond or certified check, payable to the City Treasurer. Bid deposit of the successful bidders shall be returned within forty-eight (48) hours following execution of the contract and bond as required.

#### MINOR DISCREPENCIES

Bidder is responsible for submitting all forms necessary for the City to determine compliance with State and City bidding requirements. Notwithstanding any language to the contrary contained herein, the City may exercise its discretion to allow bidders to correct or supplement submissions after bid opening, if the minor discrepancy, bid irregularity or omission is insignificant and not one related to price, quality, quantity, time of completion or performance of the contract.

**Bidders for this Contract(s) must be Pre-Qualified for at least one of the following type(s) of construction denoted by an**

Building Demolition

- 101  Asbestos Removal
- 120  House Mover

- 110  Building Demolition

Street, Utility and Site Construction

- 201  Asphalt Paving
- 205  Blasting
- 210  Boring/Pipe Jacking
- 215  Concrete Paving
- 220  Con. Sidewalk/Curb & Gutter/Misc. Flat Work
- 221  Concrete Bases and Other Concrete Work
- 222  Concrete Removal
- 225  Dredging
- 230  Fencing
- 235  Fiber Optic Cable/Conduit Installation
- 240  Grading and Earthwork
- 241  Horizontal Saw Cutting of Sidewalk
- 242  Infrared Seamless Patching
- 245  Landscaping, Maintenance
- 250  Landscaping, Site and Street
- 251  Parking Ramp Maintenance
- 252  Pavement Marking
- 255  Pavement Sealcoating and Crack Sealing
- 260  Petroleum Above/Below Ground Storage Tank Removal/Installation
- 262  Playground Installer
- 265  Retaining Walls, Precast Modular Units

- 270  Retaining Walls, Reinforced Concrete
- 275  Sanitary, Storm Sewer and Water Main Construction
- 276  Sawcutting
- 280  Sewer Lateral Drain Cleaning/Internal TV Insp.
- 285  Sewer Lining
- 290  Sewer Pipe Bursting
- 295  Soil Borings
- 300  Soil Nailing
- 305  Storm & Sanitary Sewer Laterals & Water Svc.
- 310  Street Construction
- 315  Street Lighting
- 318  Tennis Court Resurfacing
- 320  Traffic Signals
- 325  Traffic Signing & Marking
- 332  Tree pruning/removal
- 333  Tree, pesticide treatment of
- 335  Trucking
- 340  Utility Transmission Lines including Natural Gas, Electrical & Communications
- 399  Other \_\_\_\_\_

Bridge Construction

- 501  Bridge Construction and/or Repair

Building Construction

- 401  Floor Covering (including carpet, ceramic tile installation, rubber, VCT)
- 402  Building Automation Systems
- 403  Concrete
- 404  Doors and Windows
- 405  Electrical - Power, Lighting & Communications
- 410  Elevator - Lifts
- 412  Fire Suppression
- 413  Furnishings - Furniture and Window Treatments
- 415  General Building Construction, Equal or Less than \$250,000
- 420  General Building Construction, \$250,000 to \$1,500,000
- 425  General Building Construction, Over \$1,500,000
- 428  Glass and/or Glazing
- 429  Hazardous Material Removal
- 430  Heating, Ventilating and Air Conditioning (HVAC)
- 433  Insulation - Thermal
- 435  Masonry/Tuck pointing

- 437  Metals
- 440  Painting and Wallcovering
- 445  Plumbing
- 450  Pump Repair
- 455  Pump Systems
- 460  Roofing and Moisture Protection
- 464  Tower Crane Operator
- 461  Solar Photovoltaic/Hot Water Systems
- 465  Soil/Groundwater Remediation
- 466  Warning Sirens
- 470  Water Supply Elevated Tanks
- 475  Water Supply Wells
- 480  Wood, Plastics & Composites - Structural & Architectural
- 499  Other \_\_\_\_\_

State of Wisconsin Certifications

- 1  Class 5 Blaster - Blasting Operations and Activities 2500 feet and closer to inhabited buildings for quarries, open pits and road cuts.
- 2  Class 6 Blaster - Blasting Operations and Activities 2500 feet and closer to inhabited buildings for trenches, site excavations, basements, underwater demolition, underground excavations, or structures 15 feet or less in height.
- 3  Class 7 Blaster - Blasting Operations and Activities for structures greater than 15 ' in height, bridges, towers, and any of the objects or purposes listed as "Class 5 Blaster or Class 6 Blaster".
- 4  Petroleum Above/Below Ground Storage Tank Removal and Installation (Attach copies of State Certifications.)
- 5  Hazardous Material Removal (Contractor to be certified for asbestos and lead abatement per the Wisconsin Department of Health Services, Asbestos and Lead Section (A&LS).) See the following link for application: [www.dhs.wisconsin.gov/Asbestos/Cert](http://www.dhs.wisconsin.gov/Asbestos/Cert). State of Wisconsin Performance of Asbestos Abatement Certificate must be attached.
- 6  Certification number as a Certified Arborist or Certified Tree Worker as administered by the International Society of Arboriculture
- 7  Pesticide application (Certification for Commercial Applicator For Hire with the certification in the category of turf and landscape (3.0) and possess a current license issued by the DATCP)
- 8  State of Wisconsin Master Plumbers License.

## SECTION B: PROPOSAL

Please refer to the  
Bid Express Website  
at <https://bidexpress.com>  
look up contract number  
and go to  
Section B: Proposal Page

You can access all City of Madison bid solicitations for FREE at [www.bidexpress.com](http://www.bidexpress.com)

Click on the "Register for Free" button and follow the instructions to register your company and yourself. You will be asked for a payment subscription preference, since you may wish to bid online someday. Simply choose the method to pay on a 'per bid' basis. This requires no payment until / unless you actually bid online. You can also choose the monthly subscription plan at this time. You will, however, be asked to provide payment information. Remember, you can change your preference at anytime. You will then be able to complete your free registration and have full access to the site. Your free access does not require completion of the 'Digital ID' process, so you will have instant access for viewing and downloading. To be prepared in case you ever do wish to bid online, you may wish to establish your digital ID also, since you cannot bid without a Digital ID.

If you have any problems with the free registration process, you can call the bidexpress help team, toll free at 1-888-352-2439 (option 1, option1).

## **SECTION C: SMALL BUSINESS ENTERPRISE**

### **Instructions to Bidders City of Madison SBE Program Information**

#### **2 Small Business Enterprise (SBE) Program Information**

##### **2.1 Policy and Goal**

The City of Madison reaffirms its policy of nondiscrimination in the conduct of City business by maintaining a procurement process which remains open to all who have the potential and ability to sell goods and services to the City. It is the policy of the City of Madison to allow Small Business Enterprises (SBE) maximum feasible opportunity to participate in City of Madison contracting. The bidder acknowledges that its bid has been submitted in accordance with the SBE program and is for the public's protection and welfare.

Please refer to the "ADVERTISEMENT FOR BIDS" for the goal for the utilization of SBEs on this project. SBEs may participate as subcontractors, vendors and/or suppliers, which provide a commercially useful function. The dollar value for SBE suppliers or 'materials only' vendors shall be discounted to 60% for purposes of meeting SBE goals.

A bidder which achieves or exceeds the SBE goal will be in compliance with the SBE requirements of this project. In the event that the bidder is unable to achieve the SBE goal, the bidder must demonstrate that a good faith effort to do so was made. Failure to either achieve the goal or demonstrate a good faith effort to do so will be grounds for the bidder being deemed a non-responsible contractor ineligible for award of this contract.

A bidder may count towards its attainment of the SBE goal only those expenditures to SBEs that perform a commercially useful function. For purposes of evaluating a bidder's responsiveness to the attainment of the SBE goal, the contract participation by an SBE is based on the percentage of the total base bid proposed by the Contractor. The total base bid price is inclusive of all addenda.

Work performed by an SBE firm in a particular transaction can be counted toward the goal only if it involves a commercially useful function. That is, in light of industry practices and other relevant considerations, does the SBE firm have a necessary and useful role in the transaction, of a kind for which there is a market outside the context of the SBE Program, or is the firm's role a superfluous step added in an attempt to obtain credit towards goals? If, in the judgment of the Affirmative Action Division, the SBE firm will not perform a commercially useful function in the transaction, no credit towards goals will be awarded.

The question of whether a firm is performing a commercially useful function is completely separate from the question of whether the firm is an eligible SBE. A firm is eligible if it meets the definitional criteria and ownership and control requirements, as set forth in the City of Madison's SBE Program.

If the City of Madison determines that the SBE firm is performing a commercially useful function, then the City of Madison must then decide what that function is. If the commercially useful function is that of an SBE vendor / supplier that regularly transacts business with the respective product, then the City of Madison will count 60% of the value of the product supplied toward SBE goals.

To be counted, the SBE vendor / supplier must be engaged in selling the product in question to the public. This is important in distinguishing an SBE vendor / supplier, which has a regular trade with a variety of customers, from a firm which performs supplier-like functions on an ad hoc basis or for only one or two contractors with whom it has a special relationship.

A supplier of bulk goods may qualify as an eligible SBE vendor / supplier if it either maintains an inventory or owns or operates distribution equipment. With respect to the distribution equipment; e.g., a fleet of trucks, the term "operates" is intended to cover a situation in which the supplier leases the equipment on a regular basis for its entire business. It is not intended to cover a situation in which the firm simply provides drivers for trucks owned or leased by another party; e.g., a prime contractor, or leases such a party's trucks on an ad hoc basis for a specific job.

If the commercially useful function being performed is not that of a qualified SBE vendor / supplier, but rather that of delivery of products, obtaining bonding or insurance, procurement of personnel, acting as a broker or manufacturer's representative in the procurement of supplies, facilities, or materials, etc., only the fees or commissions will apply towards the goal.

For example, a business that simply transfers title of a product from manufacturer to ultimate purchaser; e. g., a sales representative who re-invoices a steel product from the steel company to the Contractor, or a firm that puts a product into a container for delivery would not be considered a qualified SBE vendor / supplier. The Contractor would not receive credit based on a percentage of the cost of the product for working with such firms.

Concerning the use of services that help the Contractor obtain needed supplies, personnel, materials or equipment to perform a contract: only the fee received by the service provider will be counted toward the goal. For example, use of a SBE sales representative or distributor for a steel company, if performing a commercially useful function at all, would entitle the Contractor receiving the steel to count only the fee paid to the representative or distributor toward the goal. This provision would also govern fees for professional and other services obtained expressly and solely to perform work relating to a specific contract.

Concerning transportation or delivery services: if an SBE trucking company picks up a product from a manufacturer or a qualified vendor / supplier and delivers the product to the Contractor, the commercially useful function it is performing is not that of a supplier, but simply that of a transporter of goods. Unless the trucking company is itself the manufacturer or a qualified vendor / supplier in the product, credit cannot be given based on a percentage of the cost of the product. Rather, credit would be allowed for the cost of the transportation service.

The City is aware that the rule's language does not explicitly mention every kind of business that may contribute work on this project. In administering these programs, the City would, on a case-by-case basis, determine the appropriate counting formula to apply in a particular situation.

## **2.2 Contract Compliance**

Questions concerning the SBE Program shall be directed to the Contract Compliance Officer of the City of Madison Department of Civil Rights, Affirmative Action Division, 210 Martin Luther King, Jr. Blvd., Room 523, Madison, WI 53703; telephone (608) 266-4910.



## 2.3 Certification of SBE by City of Madison

The Affirmative Action Division maintains a directory of SBEs which are currently certified as such by the City of Madison. Contact the Contract Compliance Officer as indicated in Section 2.2 to receive a copy of the SBE Directory or you may access the SBE Directory online at [www.cityofmadison.com/dcr/aaTBDir.cfm](http://www.cityofmadison.com/dcr/aaTBDir.cfm).

All contractors, subcontractors, vendors and suppliers seeking SBE status must complete and submit the **Targeted Business Certification Application** to the City of Madison Affirmative Action Division by the time and date established for receipt of bids. A copy of the Targeted Business Certification Application is available by contacting the Contract Compliance Officer at the address and telephone indicated in Section 2.2 or you may access the Targeted Business Certification Application online at [www.cityofmadison.com/dcr/aaTBDir.cfm](http://www.cityofmadison.com/dcr/aaTBDir.cfm). Submittal of the Targeted Business Certification Application by the time specified does not guarantee that the applicant will be certified as a SBE eligible to be utilized towards meeting the SBE goal for this project.

## 2.4 Small Business Enterprise Compliance Report

### 2.4.1 Good Faith Efforts

Bidders shall take all necessary affirmative steps to assure that SBEs are utilized when possible and that the established SBE goal for this project is achieved. A contractor who self performs a portion of the work, and is pre-qualified to perform that category of work, may subcontract that portion of the work, but shall not be required to do so. When a bidder is unable to achieve the established SBE goal, the bidder must demonstrate that a good faith effort to do so was made. Such a good faith effort should include the following:

- 2.4.1.1 Attendance at the pre-bid meeting.
- 2.4.1.2 Using the City of Madison's directory of certified SBEs to identify SBEs from which to solicit bids.
- 2.4.1.3 Assuring that SBEs are solicited whenever they are potential sources.
- 2.4.1.4 Referring prospective SBEs to the City of Madison Affirmative Action Division for certification.
- 2.4.1.5 Dividing total project requirements into smaller tasks and/or quantities, where economically feasible, to permit maximum feasible SBE participation.
- 2.4.1.6 Establishing delivery schedules, where requirements permit, which will encourage participation by SBEs.
- 2.4.1.7 Providing SBEs with specific information regarding the work to be performed.
- 2.4.1.8 Contacting SBEs in advance of the deadline to allow such businesses sufficient time to prepare a bid.
- 2.4.1.9 Utilizing the bid of a qualified and competent SBE when the bid of such a business is deemed reasonable (i.e. 5% above the lowest bidder), although not necessarily low.
- 2.4.1.10 Contacting SBEs which submit a bid, to inquire about the details of the bid and confirm that the scope of the work was interpreted as intended.
- 2.4.1.11 Completion of Cover Page (page C-6), Summary Sheet (page C-7) and SBE Contact Reports (pages C-8 and C9) if applicable.

## 2.4.2 Reporting SBE Utilization and Good Faith Efforts

The Small Business Enterprise Compliance Report is to be submitted by the bidder with the bid: This report is due by the specified bid closing time and date. Bids submitted without a completed SBE Compliance Report as outlined below may be deemed non-responsible and the bidder ineligible for award of this contract. Notwithstanding any language to the contrary contained herein, the City may exercise its discretion to allow bidders to correct or supplement submissions after bid opening, if the minor discrepancy, bid irregularity or omission is insignificant and not one related to price, quality, quantity, time of completion, performance of the contract, or percentage of SBE utilization.

2.4.2.1 If the Bidder meets or exceeds the goal established for SBE utilization, the Small Business Enterprise Compliance Report shall consist of the following:

2.4.2.1.1 **Cover Page**, Page C-6; and

2.4.2.1.2 **Summary Sheet**, C-7.

2.4.2.2 If the bidder does not meet the goal established for SBE utilization, the Small Business Enterprise Compliance Report shall consist of the following:

2.4.2.2.1 **Cover Page**, Page C-6;

2.4.2.2.2 **Summary Sheet**, C-7; and

2.4.2.2.3 **SBE Contact Report**, C-8 and C-9. (A separate Contact Report must be completed for each applicable SBE which is not utilized.)

## 2.5 Appeal Procedure

A bidder which does not achieve the established goal and is found non-responsible for failure to demonstrate a good faith effort to achieve such goal and subsequently denied eligibility for award of contract may appeal that decision to the Small Business Enterprises Appeals Committee. All appeals shall be made in writing, and shall be delivered to and received by the City Engineer no later than 4:30 PM on the third business day following the bidder's receipt of the written notification of ineligibility by the Affirmative Action Division Manager. Postmark not acceptable. The notice of appeal shall state the basis for the appeal of the decision of the Affirmative Action Division Manager. The Appeal shall take place in accordance with Madison General Ordinance 33.54.

## 2.6 SBE Requirements After Award of the Contract

The successful bidder shall identify SBE subcontractors, suppliers and vendors on the subcontractor list in accordance with the specifications. The Contractor shall submit a detailed explanation of any variances between the listing of SBE subcontractors, vendors and/or suppliers on the subcontractor list and the Contractor's SBE Compliance Report for SBE participation.

No change in SBE subcontractors, vendors and/or suppliers from those SBEs indicated in the SBE Compliance Report will be allowed without prior approval from the Engineer and the Affirmative Action Division. The contractor shall submit in writing to the City of Madison Affirmative Action Division a request to change any SBE citing specific reasons which necessitate such a change. The Affirmative Action Division will use a general test of reasonableness in approving or rejecting the contractor's request for change. If the request is approved, the Contractor will make every effort to utilize another SBE if available.

The City will monitor the project to ensure that the actual percentage commitment to SBE firms is carried out.

## **2.7 SBE Definition and Eligibility Guidelines**

A Small Business Enterprise is a business concern awarded certification by the City of Madison. For the purposes of this program a Small Business Enterprise is defined as:

- A. An independent business operated under a single management. The business may not be a subsidiary of any other business and the stock or ownership may not be held by any individual or any business operating in the same or a similar field. In determining whether an entity qualifies as a SBE, the City shall consider all factors relevant to being an independent business including, but not limited to, the date the business was established, adequacy of its resources for the work in which it proposes to involve itself, the degree to which financial, equipment leasing and other relationships exist with other ineligible firms in the same or similar lines of work. SBE owner(s) shall enjoy the customary incidents of ownership and shall share in the risks and profits commensurate with their enjoyment interests, as demonstrated by an examination of the substance rather than form or arrangements that may be reflected in its ownership documents.
- B. A business that has averaged no more than \$4.0 million in annual gross receipts over the prior three year period and the principal owner(s) do not have a personal net worth in excess of \$1.32 million.

Firm and/or individuals that submit fraudulent documents/testimony may be barred from doing business with the City and/or forfeit existing contracts.

SBE certification is valid for one (1) year unless revoked.

**BLACKHAWK WATER TOWER  
CONTRACT NO. 7821**

**Small Business Enterprise Compliance Report**

**This information may be submitted electronically through  
Bid Express or submitted with bid in sealed envelope.**

**Cover Sheet**

Prime Bidder Information

Company: \_\_\_\_\_

Address: \_\_\_\_\_

Telephone Number: \_\_\_\_\_ Fax Number: \_\_\_\_\_

Contact Person/Title: \_\_\_\_\_

Prime Bidder Certification

I, \_\_\_\_\_, \_\_\_\_\_ of  
Name Title

\_\_\_\_\_ certify that the information  
Company

contained in this SBE Compliance Report is true and correct to the best of my knowledge and belief.

\_\_\_\_\_  
Witness' Signature

\_\_\_\_\_  
Bidder's Signature

\_\_\_\_\_  
Date

**BLACKHAWK WATER TOWER  
CONTRACT NO. 7821**

**Small Business Enterprise Compliance Report**

**Summary Sheet**

SBE Subcontractors Who Are NOT Suppliers

Name(s) of SBEs Utilized	Type of Work	% of Total Bid Amount
		%
		%
		%
		%
		%
		%
		%
		%
		%
		%
		%
		%
		%
		%
		%
		%
<b>Subtotal SBE who are NOT suppliers:</b>		_____ %

SBE Subcontractors Who Are Suppliers

Name(s) of SBEs Utilized	Type of Work	% of Total Bid Amount
		%
		%
		%
		%
		%
		%
		%
<b>Subtotal Contractors who are suppliers:</b>	_____ % x 0.6 = _____	% (discounted to 60%)

**Total Percentage of SBE Utilization:** \_\_\_\_\_ %.

**BLACKHAWK WATER TOWER  
CONTRACT NO. 7821**

**Small Business Enterprise Compliance Report**

**SBE Contact Report**

Submit separate copy of this form for each SBE which you are not able to utilize towards meeting the SBE goal for this project. Attach separate sheets if necessary.

SBE Information

Company: \_\_\_\_\_

Address: \_\_\_\_\_

Telephone Number: \_\_\_\_\_

Contact Person/Title: \_\_\_\_\_

1. Outline below all efforts to solicit a bid from the above SBE. Include date, means of contact, who from your company made this contact and the result.

\_\_\_\_\_  
\_\_\_\_\_  
\_\_\_\_\_

2. Describe the information provided to the aforementioned SBE regarding the scope of work for which he/she was to provide a bid.

\_\_\_\_\_  
\_\_\_\_\_  
\_\_\_\_\_

Is this the same scope of work on which the subcontractor you intend to utilize based his/her bid?

Yes     No

3. Did this SBE submit a bid?     Yes     No

4. Is the General Contractor pre-qualified to self-perform this category of work?

Yes     No

5. If you responded "Yes" to Question 3, please check the items below which apply and provide the requested detail. If you responded "No" to Question 3, please skip ahead to item 6 below.

The SBE listed above is unavailable for work on this project for the following reasons. Provide specific detail for this conclusion.

---

---

The SBE listed above is unqualified for work on this project. Provide specific details for this conclusion.

---

---

The SBE listed above provided a price that was unreasonable (i.e. more than 5% above the lowest bidder). Provide specific detail for this conclusion including the SBE's price and the price of the subcontractor you intend to utilize.

---

---

A contract with the SBE listed above may constitute a breach of the bidder's collective bargaining agreements. Provide specific detail for this conclusion including, but not limited to, correspondence from the SBE indicating it will not sign a project labor agreement and/or correspondence from the applicable trade union indicating a project labor agreement will not be allowed at the time of project bidding.

---

---

Other; please specify reason(s) other than listed above which made it impossible for you to utilize this SBE on this project.

---

---

6. Describe any other good faith efforts:

---

---

## **SECTION D: SPECIAL PROVISIONS**

### **BLACKHAWK WATER TOWER CONTRACT NO. 7821**

It is the intent of these Special Provisions to set forth the final contractual intent as to the matter involved and shall prevail over the Standard Specifications and plans whenever in conflict therewith. In order that comparisons between the Special Provisions can be readily made, the numbering system for the Special Provisions is equivalent to that of the Specifications.

Whenever in these Specifications the term "Standard Specifications" appears, it shall be taken to refer to the City of Madison Standard Specifications for Public Works Construction and Supplements thereto.

#### **SECTION 102.12: BEST VALUE CONTRACTING**

This Contract shall be considered a Best Value Contract if the Contractor's bid is equal to or greater than \$59,000 for a single trade contract; or equal to or greater than \$288,000 for a multi-trade contract pursuant to MGO 33.07(7).



**MADISON WATER UTILITY  
BLACKHAWK WATER TOWER  
TECHNICAL SPECIFICATIONS**

Baxter & Woodman, Inc.  
Crystal Lake, IL  
815.459.1260

Chicago, IL  
815.459.1260

DeKalb, IL  
815.459.1260

Grayslake, IL  
815.459.1260

Mokena, IL  
815.459.1260

Burlington, WI  
815.459.1260

Madison, WI  
608.277.1230

Milwaukee, WI  
815.459.1260

PROJECT TITLE PAGE  
00 01 01 (150826.40)

00 01 07

SEALS PAGE

December 27, 2016

1. Specifications of materials and labor required for the construction work shown on the Drawings are prepared by Baxter & Woodman, Inc., Consulting Engineers.
2. The Drawings which accompanies these Specifications are titled "Madison Water Utility, Madison, Wisconsin, Blackhawk Water Tower".
3. Copyright 2016 and 2017 by Baxter & Woodman, Inc. All Rights Reserved. No part of these Specifications or the accompanying Drawings may be reproduced by any means, or otherwise reused without the prior written permission of Baxter & Woodman, Inc.

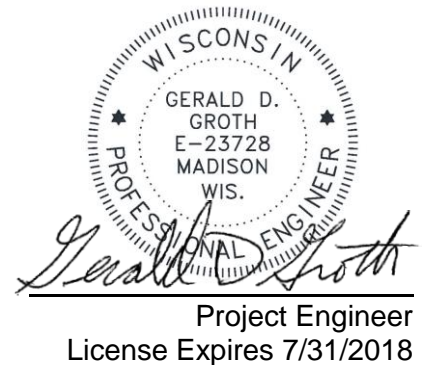

BAXTER & WOODMAN, INC.  
STATE OF WISCONSIN – PROFESSIONAL DESIGN FIRM  
LICENSE NO. 484-11 - EXPIRES 1/31/2018

SEALS PAGE  
00 01 07-1 (150826.40)

**MADISON WATER UTILITY  
BLACKHAWK WATER TOWER  
TECHNICAL SPECIFICATIONS**

**TABLE OF CONTENTS**

<u>Section Number</u>	<u>Section</u>
<u>DIVISION 00</u>	- PROCUREMENT AND CONTRACTING REQUIREMENTS
00 01 01	PROJECT TITLE PAGE
00 01 07	SEALS PAGE
00 01 10	TABLE OF CONTENTS
00 31 32.13	SUBSURFACE DRILLING AND SAMPLING INFORMATION
00 73 00.13	SUPPLEMENTARY CONDITIONS
<u>DIVISION 01</u>	- GENERAL REQUIREMENTS
01 14 11	CONTRACTOR USE OF PREMISES
01 26 13	REQUESTS FOR INTERPRETATION
01 26 13.13	RFI FORM
01 31 14	PROJECT COORDINATION AND CONSTRUCTION PHASING
01 31 19	PROJECT MEETINGS
01 32 16	CONSTRUCTION PROGRESS SCHEDULES
01 33 01	SUBMITTALS
01 41 26	PERMITS
01 42 13	ABBREVIATIONS AND ACRONYMS
01 45 29	TESTING LABORATORY SERVICES
01 50 00	TEMPORARY FACILITIES AND CONTROLS
01 61 01	GENERAL EQUIPMENT REQUIREMENTS
01 62 01	PRODUCT OPTIONS AND SUBSTITUTIONS
01 66 11	STORAGE AND PROTECTION OF MATERIAL AND EQUIPMENT
01 73 29	CUTTING AND PATCHING
01 74 23	FINAL CLEANING
01 77 01	CONTRACT CLOSEOUT
01 78 26	OPERATION AND MAINTENANCE MANUAL
01 78 39	PROJECT RECORD DOCUMENTS
01 91 58	FACILITY STARTUP
<u>DIVISION 03</u>	- CONCRETE
03 30 00	CAST-IN-PLACE CONCRETE
<u>DIVISION 04</u>	- MASONRY
04 01 00	MAINTENANCE OF MASONRY
04 20 00	UNIT MASONRY

Table of Contents - continued

<u>Section Number</u>	<u>Section</u>
<u>DIVISION 05</u>	- METALS
05 50 00	METAL FABRICATIONS
<u>DIVISION 06</u>	- WOOD, PLASTICS, AND COMPOSITES
06 10 00	ROUGH CARPENTRY
<u>DIVISION 07</u>	- THERMAL AND MOISTURE PROTECTION
07 21 00	THERMAL INSULATION
07 60 00	FLASHING AND SHEET METAL
07 92 00	JOINT SEALANTS
<u>DIVISION 08</u>	- OPENINGS
08 11 19.26	FIBERGLASS REINFORCED PLASTIC DOORS, FRAMES, AND HARDWARE
08 36 13	SECTIONAL DOORS
08 71 00	DOOR HARDWARE
08 91 00	LOUVERS
<u>DIVISION 09</u>	- FINISHES
09 90 00	PAINTING AND COATING
<u>DIVISION 22</u>	- PLUMBING
22 19 13	PIPE AND PIPE FITTINGS
22 19 23	VALVES
22 19 26	GAUGES
22 19 33	PIPE INSULATION
22 19 43	PLUMBING AND FIXTURES
<u>DIVISION 23</u>	- HEATING, VENTILATING, AND AIR CONDITIONING (HVAC)
23 00 00	HEATING, VENTILATING, AND AIR CONDITIONING (HVAC)
23 37 13	DIFFUSERS, REGISTERS, AND GRILLES
23 85 00	ELECTRIC HEATERS
<u>DIVISION 26</u>	- ELECTRICAL
26 05 19	LOW-VOLTAGE ELECTRICAL POWER CONDUCTORS AND CABLES
26 05 23	CONTROL-VOLTAGE ELECTRICAL POWER CABLES
26 05 26	GROUNDING AND BONDING OF ELECTRICAL SYSTEMS
26 05 29	HANGERS AND SUPPORTS FOR ELECTRICAL SYSTEMS

Table of Contents - continued

<u>Section Number</u>	<u>Section</u>
<u>DIVISION 26</u>	- ELECTRICAL
26 05 33	RACEWAY AND BOXES FOR ELECTRICAL SYSTEMS
26 05 53	IDENTIFICATION FOR ELECTRICAL SYSTEMS
26 09 95	PUSHBUTTONS, SELECTOR SWITCHES, AND PILOT LIGHTS
26 24 16	PANELBOARDS
26 27 26	WIRING DEVICES
26 28 00	LOW-VOLTAGE CIRCUIT PROTECTIVE DEVICES
26 28 16	ENCLOSED SWITCHES AND CIRCUIT BREAKERS
26 60 20	ELECTRICAL SERVICE
<u>DIVISION 28</u>	- ELECTRONIC SAFETY AND SECURITY
28 31 00	FIRE DETECTION AND ALARM
<u>DIVISION 31</u>	- EARTHWORK
31 16 00	SITE PREPARATION
31 22 22	EARTHWORK FOR ROADS, DRIVEWAYS, AND WALKS
31 23 39	EXCAVATING, BACKFILLING, AND COMPACTING
31 23 79	TRENCHING, BACKFILLING, AND COMPACTING
31 25 00	SOIL EROSION AND SEDIMENT CONTROLS
<u>DIVISION 32</u>	- EXTERIOR IMPROVEMENTS
32 10 00.13	ROADS, DRIVEWAYS, AND WALKS
32 31 13	GATES
32 92 00.13	LAWNS AND GRASSES
32 93 79	TREES, PLANTS, AND GROUND COVER
<u>DIVISION 33</u>	- UTILITIES
33 16 19.33	CONCRETE/STEEL COMPOSITE WATER STORAGE TANKS
33 32 26	SUBMERSIBLE SUMP PUMP PUMPING SYSTEM
33 42 13	PIPE CULVERTS
<u>DIVISION 40</u>	- PROCESS INTEGRATION
40 90 10	PROCESS CONTROL SYSTEM FOR WATER SYSTEM FACILITIES
40 91 10	PROCESS INSTRUMENTATION AND CONTROL SCHEDULE
40 91 19.29	LIQUID PRESSURE PROCESS MEASUREMENT DEVICES
40 91 23.36	LEVEL PROCESS MEASUREMENT DEVICES
40 94 27	DISTRIBUTED INPUT/OUTPUT (DIO) DEVICES
40 94 43	PROGRAMMABLE LOGIC PROCESS CONTROLLERS

Table of Contents - continued

<u>Section Number</u>	<u>Section</u>
<u>DIVISION 40</u>	- PROCESS INTEGRATION
40 95 13	PROCESS CONTROL PANELS AND HARDWARE
40 95 74	PROCESS CONTROL SIGNAL CONDITIONERS/CONVERTERS
40 95 88	POWER SUPPLY SYSTEMS
40 97 96	PROCESS SWITCHES

00 31 32.13

SUBSURFACE DRILLING AND SAMPLING INFORMATION

PART 1 - GENERAL

1.1 SUMMARY

- A. This Section describes soils investigation at the site, and use of data resulting from that investigation.

1.2 SOILS INVESTIGATION REPORT

- A. General:
  - 1. A soils investigation report has been prepared for the site of this Work by CGC, Inc.
  - 2. Attached are copies of boring logs for the 1.0 MG elevated tank proposed for the site south of Old Sauk Road and east of Pioneer Road. Three (3) soil borings drilled at the locations as indicated on the Drawings.
  - 3. Copies of the soils investigation report may be obtained from the Engineers, Baxter & Woodman, Inc., upon request.

- B. Use of data:
  - 1. The soil investigation report was obtained only for the Engineer's use in design and is not a part of the Contract Documents.
  - 2. The geotechnical data is included for Bidders' information and represents only the subsurface conditions at the exact location of each boring, but is not a warranty of subsurface conditions. Interpretation of geotechnical data is the responsibility of the Bidders.
  - 3. Bidders should visit the site and acquaint themselves with existing conditions.
  - 4. Prior to bidding, Bidders may make their own subsurface investigations to satisfy themselves as to site and subsurface conditions, but such investigations may be performed only under time schedules and arrangements approved in advance by the Engineer.
  - 5. The technical data in the above report, upon which the Contractor may rely, consists of boring methods, level of subsurface water, boring logs, laboratory test methods and results, and boring locations all as of the date made.
    - a. Engineer accepts no responsibility for accuracy of the soil data or water level information. Soil information, included with these Contract Documents, was not obtained for the purposes of designing excavations and trenches. Soil information was used by Engineer for design purposes only. Contractor shall assure itself by personal examination as to subsurface conditions and shall provide its own investigations and make its own assumptions to comply with OSHA and any other applicable laws and regulations regarding excavation and trenching requirements.

END OF SUBSURFACE DRILLING AND SAMPLING INFORMATION

SUBSURFACE DRILLING AND SAMPLING INFORMATION

00 31 32.13-1 (150826.40)

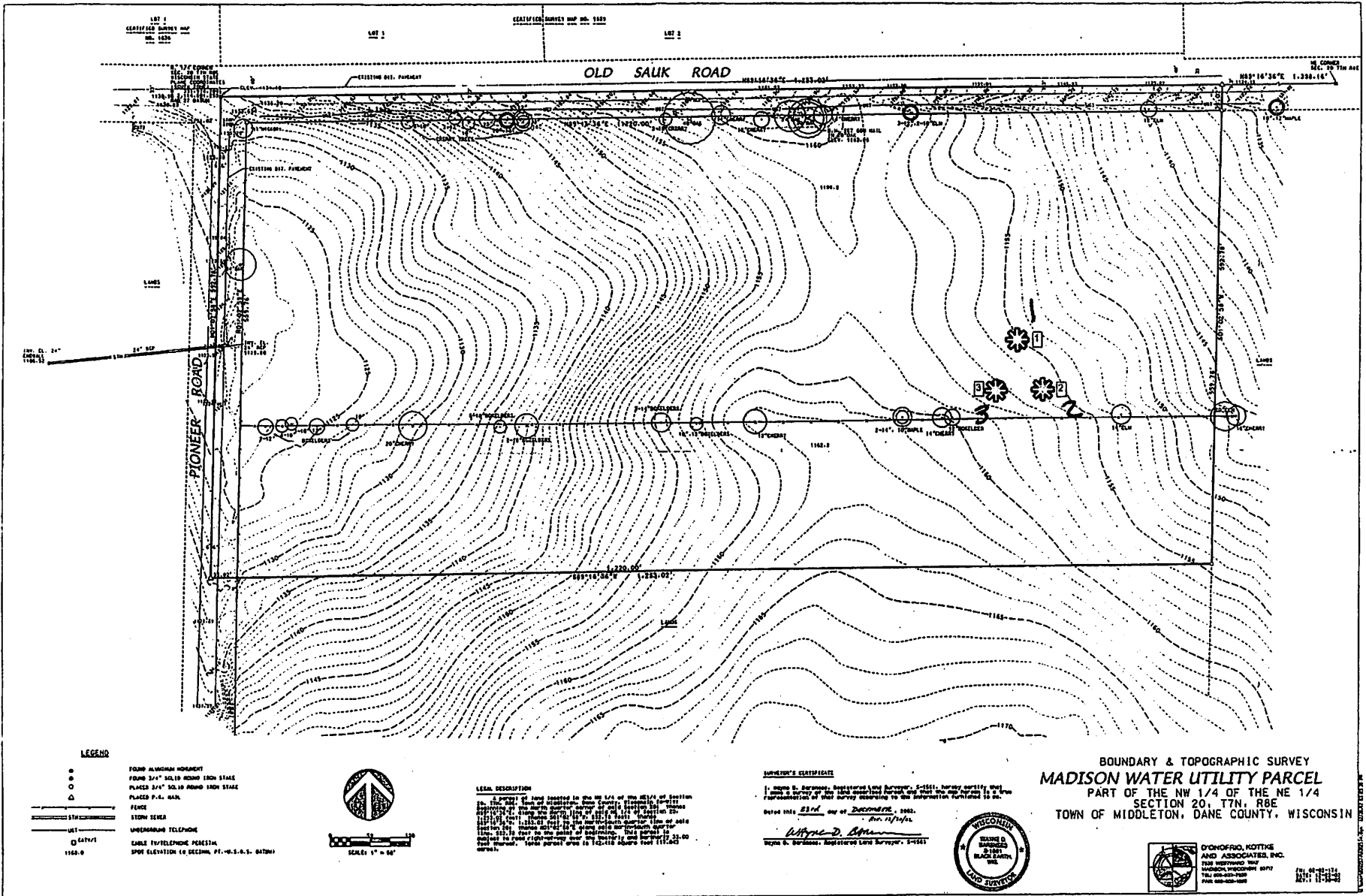

BOUNDARY & TOPOGRAPHIC SURVEY  
**MADISON WATER UTILITY PARCEL**  
 PART OF THE NW 1/4 OF THE NE 1/4  
 SECTION 20, T7N, R8E  
 TOWN OF MIDDLETON, DANE COUNTY, WISCONSIN

**Legend**

☼ Denotes Boring Location and Number

**Notes**

- Soil borings were performed by Badger State Drilling in July 2016.
- Base map was prepared by D'Onofrio Kottke and provided by Madison Water Utility.
- Boring locations are approximate.

Scale: Reduced

Date: 7/20/16
Job No. C16051-6

CGC, Inc.

**SOIL BORING LOCATION EXHIBIT**  
**Proposed Water Tower**  
**Pioneer & Old Sauk Roads**  
**Madison, Wisconsin**





# LOG OF TEST BORING

Project Pioneer/Old Sauk Water Tower  
 PT #10000  
 Location Madison, WI

Boring No. 1  
 Surface Elevation (ft) 1155.1  
 Job No. C16051-6  
 Sheet 1 of 1

2921 Perry Street, Madison, WI 53713 (608) 288-4100, FAX (608) 288-7887

SAMPLE					VISUAL CLASSIFICATION and Remarks	SOIL PROPERTIES				
No.	Rec (in.)	Moist	N	Depth (ft)		qu (qa) (tsf)	W	LL	PL	LI
1	14	M	6	0	10.5 in. TOPSOIL	(1.0)	26.3			
2	14	M	11	5	Medium Stiff to Stiff, Brown Lean CLAY, Trace Sand and Gravel (CL)					
3	18	M	11	10	Medium Dense to Dense, Brown, Fine to Medium SAND, Some Silt and Gravel, Scattered Cobbles/Boulders (SM)					
4	16	M	20	15						
5	0	M	38	20	Weathered to Competent Orange-Brown Sandstone BEDROCK					
6	12	M	34	25	Hard Drilling Noted Near 15 ft					
7	10	M	43	30						
8	0		50/4"	35						
9	0		50/2"	40						
A	0			43.5	Core Run A: 38.5 - 43.5 ft 0% Recovery; SPT blow count at 38.5 ft = 50/2"					
10	0		50/1"	45						
11	0		50/2"	50	End of Boring at 50 ft					
				55	Backfilled with Bentonite Slurry and Chips, Topsoil Cover					
				60						
				65						
				70						

## WATER LEVEL OBSERVATIONS

While Drilling  Upon Completion of Drilling \_\_\_\_\_  
 Time After Drilling \_\_\_\_\_  
 Depth to Water \_\_\_\_\_  
 Depth to Cave in \_\_\_\_\_

## GENERAL NOTES

Start 7/1/16 End 7/1/16  
 Driller BSD Chief KD Rig D-50  
 Logger DD Editor ESF  
 Drill Method 2.25" HSA to 10 ft; 3 7/8" RB with Mud to 50 ft; Automatic Hammer

The stratification lines represent the approximate boundary between soil types and the transition may be gradual.



# LOG OF TEST BORING

Project Pioneer/Old Sauk Water Tower  
 PT #10001  
 Location Madison, WI

Boring No. 2  
 Surface Elevation (ft) 1155.8  
 Job No. C16051-6  
 Sheet 1 of 1

2921 Perry Street, Madison, WI 53713 (608) 288-4100, FAX (608) 288-7887

SAMPLE					VISUAL CLASSIFICATION and Remarks	SOIL PROPERTIES				
No.	Rec (in.)	Moist	N	Depth (ft)		qu (qa) (tsf)	W	LL	PL	LI
1	14	M	8	0	10 in. TOPSOIL	(1.75)	28.2			
2	14	M	5	5	Stiff, Brown Lean CLAY, Trace Sand and Gravel (CL)	(.25)				
3	16	M	13	10	Loose to Medium Dense, Brown Fine to Medium SAND, Some Silt and Gravel, Scattered Cobbles/Boulders (SM)					
4	14	M	10	10	Very Soft and Sandy Near 3.5 ft					
5	8	M/W	13	15						
6	12	M	37	20	Weathered to Competent Orange-Brown Sandstone BEDROCK					
7	12	M	47	25						
8	12	M	73/10"	30	Hard Drilling Noted Near 30 ft					
9	0	W	50/1"	35						
10	1	M/W	50/2"	40						
A				45	Core Run A: 43.5 - 48.5 ft 0% Recovery: SPT blow count at 43.5 ft = 50/1"					
11	0		50/1"	50	End of Boring at 50 ft					
				55	Backfilled with Bentonite Slurry and Chips, Topsoil Cover					
				60						
				65						
				70						

WATER LEVEL OBSERVATIONS					GENERAL NOTES				
While Drilling	<input checked="" type="checkbox"/>	Upon Completion of Drilling	<input type="checkbox"/>		Start	7/1/16	End	7/1/16	
Time After Drilling					Driller	BSD	Chief	KD	Rig D-50
Depth to Water					Logger	DD	Editor	ESF	
Depth to Cave in					Drill Method	2.25" HSA to 10 ft; 3 7/8 RB with Mud to 50 ft; Automatic Hammer...			
The stratification lines represent the approximate boundary between soil types and the transition may be gradual.									



# LOG OF TEST BORING

Project Pioneer/Old Sauk Water Tower  
 PT #10002  
 Location Madison, WI

Boring No. 3  
 Surface Elevation (ft) 1156.4  
 Job No. C16051-6  
 Sheet 1 of 1

2921 Perry Street, Madison, WI 53713 (608) 288-4100, FAX (608) 288-7887

SAMPLE					VISUAL CLASSIFICATION and Remarks	SOIL PROPERTIES				
No.	Rec (in.)	Moist	N	Depth (ft)		qu (qa) (tsf)	W	LL	PL	LI
1	12	M	6	0-12	12 in. TOPSOIL	(1.0)	23.0			
2	12	M	9	12-18	Medium Stiff to Stiff, Brown Lean CLAY, Trace Sand and Gravel (CL)					
3	14	M	20	18-22	Loose to Medium Dense, Brown Fine to Medium SAND, Some Silt and Gravel, Scattered Cobbles/Boulders (SM)					
4	14	M	12	22-26						
5	14	M	10	26-30						
6	16	M	64	30-36						
7	18	M	49	36-42	Weathered to Competent Orange-Brown Sandstone BEDROCK Firm Drilling Noted Near 17 ft					
8	8	M	50/2"	42-44						
9	0		50/2"	44-46	Core Run A: 43.5 - 53.5 ft 0% Recovery; SPT blow count at 43.5 ft = 50/1"					
10	0		50/1"	46-48						
A	0			48-53.5						
11	0		50/3"	53.5-56.5	End of Boring at 60 ft  Backfilled with Bentonite Slurry and Chips, Topsoil Cover					
				56.5-60						
				60-65						
				65-70						

## WATER LEVEL OBSERVATIONS

While Drilling  Upon Completion of Drilling \_\_\_\_\_  
 Time After Drilling \_\_\_\_\_  
 Depth to Water \_\_\_\_\_  
 Depth to Cave in \_\_\_\_\_

## GENERAL NOTES

Start 6/30/16 End 6/30/16  
 Driller BSD Chief KD Rig D-50  
 Logger DD Editor ESF  
 Drill Method 2.25" HSA to 30 ft; 3 7/8  
RB with Mud to 60 ft; Automatic Hammer

The stratification lines represent the approximate boundary between soil types and the transition may be gradual.

**LOG OF TEST BORING**  
*General Notes*

**DESCRIPTIVE SOIL CLASSIFICATION**

Grain Size Terminology

Soil Fraction	Particle Size	U.S. Standard Sieve Size
Boulders .....	Larger than 12" .....	Larger than 12"
Cobbles .....	3" to 12" .....	3" to 12"
Gravel: Coarse.....	¾" to 3" .....	¾" to 3"
Fine.....	4.76 mm to ¾".....	#4 to ¾"
Sand: Coarse.....	2.00 mm to 4.76 mm.....	#10 to #4
Medium .....	0.42 to mm to 2.00 mm .....	#40 to #10
Fine .....	0.074 mm to 0.42 mm.....	#200 to #40
Silt.....	0.005 mm to 0.074 mm.....	Smaller than #200
Clay.....	Smaller than 0.005 mm.....	Smaller than #200

Plasticity characteristics differentiate between silt and clay.

General Terminology

- Physical Characteristics  
Color, moisture, grain shape, fineness, etc.
- Major Constituents  
Clay, silt, sand, gravel
- Structure  
Laminated, varved, fibrous, stratified, cemented, fissured, etc.
- Geologic Origin  
Glacial, alluvial, eolian, residual, etc.

Relative Density

Term	"N" Value
Very Loose.....	0 - 4
Loose.....	4 - 10
Medium Dense.....	10 - 30
Dense.....	30 - 50
Very Dense.....	Over 50

Relative Proportions Of Cohesionless Soils

Proportional Term	Defining Range by Percentage of Weight
Trace.....	0% - 5%
Little.....	5% - 12%
Some.....	12% - 35%
And .....	35% - 50%

Consistency

Term	q <sub>u</sub> -tons/sq. ft
Very Soft.....	0.0 to 0.25
Soft.....	0.25 to 0.50
Medium.....	0.50 to 1.0
Stiff.....	1.0 to 2.0
Very Stiff.....	2.0 to 4.0
Hard.....	Over 4.0

Organic Content by Combustion Method

Soil Description	Loss on Ignition
Non Organic.....	Less than 4%
Organic Silt/Clay.....	4 - 12%
Sedimentary Peat.....	12% - 50%
Fibrous and Woody Peat...	More than 50%

Plasticity

Term	Plastic Index
None to Slight.....	0 - 4
Slight.....	5 - 7
Medium.....	8 - 22
High to Very High ..	Over 22

The penetration resistance, N, is the summation of the number of blows required to effect two successive 6" penetrations of the 2" split-barrel sampler. The sampler is driven with a 140 lb. weight falling 30" and is seated to a depth of 6" before commencing the standard penetration test.

**SYMBOLS**

Drilling and Sampling

- CS – Continuous Sampling
- RC – Rock Coring: Size AW, BW, NW, 2"W
- RQD – Rock Quality Designation
- RB – Rock Bit/Roller Bit
- FT – Fish Tail
- DC – Drove Casing
- C – Casing: Size 2 ½", NW, 4", HW
- CW – Clear Water
- DM – Drilling Mud
- HSA – Hollow Stem Auger
- FA – Flight Auger
- HA – Hand Auger
- COA – Clean-Out Auger
- SS - 2" Dia. Split-Barrel Sample
- 2ST – 2" Dia. Thin-Walled Tube Sample
- 3ST – 3" Dia. Thin-Walled Tube Sample
- PT – 3" Dia. Piston Tube Sample
- AS – Auger Sample
- WS – Wash Sample
- PTS – Peat Sample
- PS – Pitcher Sample
- NR – No Recovery
- S – Sounding
- PMT – Borehole Pressuremeter Test
- VS – Vane Shear Test
- WPT – Water Pressure Test

Laboratory Tests

- q<sub>a</sub> – Penetrometer Reading, tons/sq ft
- q<sub>u</sub> – Unconfined Strength, tons/sq ft
- W – Moisture Content, %
- LL – Liquid Limit, %
- PL – Plastic Limit, %
- SL – Shrinkage Limit, %
- LI – Loss on Ignition
- D – Dry Unit Weight, lbs/cu ft
- pH – Measure of Soil Alkalinity or Acidity
- FS – Free Swell, %

Water Level Measurement

- ▽ - Water Level at Time Shown
- NW – No Water Encountered
- WD – While Drilling
- BCR – Before Casing Removal
- ACR – After Casing Removal
- CW – Cave and Wet
- CM – Caved and Moist

Note: Water level measurements shown on the boring logs represent conditions at the time indicated and may not reflect static levels, especially in cohesive soils.

# CGC, Inc.

Madison - Milwaukee

# Unified Soil Classification System

## UNIFIED SOIL CLASSIFICATION AND SYMBOL CHART

### COARSE-GRAINED SOILS

(more than 50% of material is larger than No. 200 sieve size)

#### Clean Gravels (Less than 5% fines)



**GW** Well-graded gravels, gravel-sand mixtures, little or no fines

**GP** Poorly-graded gravels, gravel-sand mixtures, little or no fines

#### Gravels with fines (More than 12% fines)



**GM** Silty gravels, gravel-sand-silt mixtures

**GC** Clayey gravels, gravel-sand-clay mixtures

#### Clean Sands (Less than 5% fines)

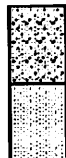

**SW** Well-graded sands, gravelly sands, little or no fines

**SP** Poorly graded sands, gravelly sands, little or no fines

#### Sands with fines (More than 12% fines)



**SM** Silty sands, sand-silt mixtures

**SC** Clayey sands, sand-clay mixtures

### FINE-GRAINED SOILS

(50% or more of material is smaller than No. 200 sieve size.)



**ML** Inorganic silts and very fine sands, rock flour, silty or clayey fine sands or clayey silts with slight plasticity

**CL** Inorganic clays of low to medium plasticity, gravelly clays, sandy clays, silty clays, lean clays

**OL** Organic silts and organic silty clays of low plasticity



**MH** Inorganic silts, micaceous or diatomaceous fine sandy or silty soils, elastic silts

**CH** Inorganic clays of high plasticity, fat clays

**OH** Organic clays of medium to high plasticity, organic silts



**PT** Peat and other highly organic soils

**GRAVELS**  
More than 50% of coarse fraction larger than No. 4 sieve size

**SANDS**  
50% or more of coarse fraction smaller than No. 4 sieve size

**SILTS AND CLAYS**  
Liquid limit less than 50%

**SILTS AND CLAYS**  
Liquid limit 50% or greater

**HIGHLY ORGANIC SOILS**

## LABORATORY CLASSIFICATION CRITERIA

**GW**  $C_u = \frac{D_{60}}{D_{10}}$  greater than 4;  $C_c = \frac{D_{30}}{D_{10} \times D_{60}}$  between 1 and 3

**GP** Not meeting all gradation requirements for GW

**GM** Atterberg limits below "A" line or P.I. less than 4

**GC** Atterberg limits above "A" line or P.I. greater than 7

Above "A" line with P.I. between 4 and 7 are borderline cases requiring use of dual symbols

**SW**  $C_u = \frac{D_{60}}{D_{10}}$  greater than 4;  $C_c = \frac{D_{30}}{D_{10} \times D_{60}}$  between 1 and 3

**SP** Not meeting all gradation requirements for GW

**SM** Atterberg limits below "A" line or P.I. less than 4

**SC** Atterberg limits above "A" line with P.I. greater than 7

Limits plotting in shaded zone with P.I. between 4 and 7 are borderline cases requiring use of dual symbols

Determine percentages of sand and gravel from grain-size curve. Depending on percentage of fines (fraction smaller than No. 200 sieve size), coarse-grained soils are classified as follows:

Less than 5 percent ..... GW, GP, SW, SP  
 More than 12 percent ..... GM, GC, SM, SC  
 5 to 12 percent ..... Borderline cases requiring dual symbols

## PLASTICITY CHART

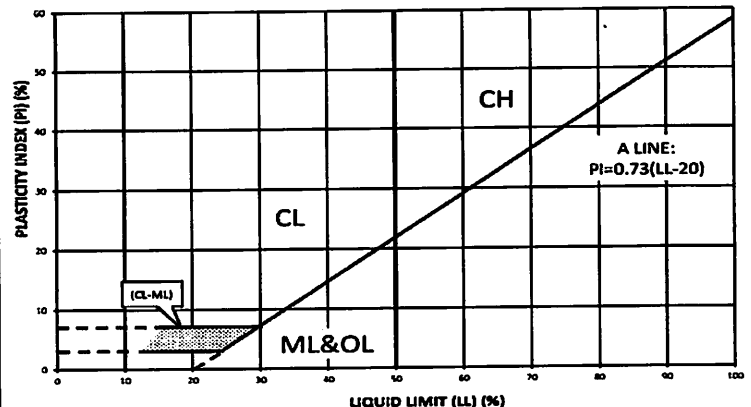

00 73 00.13

SUPPLEMENTARY CONDITIONS

PART 1 - GENERAL

1.1 SUPPLEMENTARY CONDITIONS

- A. These Supplementary Conditions add to but do not subtract from the General Conditions required by the City of Madison.

These Supplementary Conditions, as noted below; modify, change, delete from or add to the "Standard General Conditions of the Construction Contract" EJCDC No. C-700, 2007 edition. Where any Article of the General Conditions is modified, or any Paragraph, Subparagraph, or Clause thereof is modified or deleted by these Supplementary Conditions, the unaltered provisions of that Article, Paragraph, Subparagraph, or Clause shall remain in effect.

The City of Madison and EJCDC General Conditions also may be supplemented elsewhere in the Contract Documents by provisions located in, but not necessarily limited to Division 01 of the Specifications.

1.2 ARTICLE 1 – DEFINITIONS AND TERMINOLOGY

- A. SC-1
  - 1. The terms used in these Supplementary Conditions which are defined in the Standard General Conditions of the Construction Contract have the identical meaning assigned to them in said General Conditions.

- B. SC-(1.01A.17)
  - 1. The term "Drawings" and the term "Plans" shall be considered synonymous whenever and wherever used in the Contract Documents.

- 2. The following Drawings are part of the Contract Documents:

Drawings titled: Blackhawk Water Tower

Madison Water Utility Project No.: 10445/Contract No.: 7821

Baxter & Woodman, Inc. Project No.: 150826.40

Owner: Madison Water Utility, City of Madison, Wisconsin

Sheets: Consisting of 16 sheets prepared by Baxter & Woodman, Inc.

SUPPLEMENTARY CONDITIONS

00 73 00.13-1 (150826.40)

1.3 ARTICLE 2 - PRELIMINARY MATTERS

A. SC-2.01.B

1. Delete paragraph 2.01.B in its entirety and substitute the following:

2.01.B When Contractor delivers the executed Agreements to Owner, Contractor shall also deliver to Owner, with copies to each additional insured indicated in paragraphs 5.03 through 5.06, certificates of insurance which Contractor is required to purchase and maintain in accordance with paragraphs 5.03 and 5.04.

B. SC-2.02

1. Delete paragraph 2.02 in its entirety and substitute the following:

2.02 "Engineer will provide an electronic copy of the Drawings and Project Manual to the Contractor at the Preconstruction Conference."

C. SC-2.03

1. Under paragraph 2.03, delete the last sentence in its entirety.

D. SC-2.05.A

1. Delete paragraph 2.05.A in its entirety.

E. SC-2.05.A.1 through 2.05.A.3

1. Delete paragraphs 2.05.A.1 through 2.05.A.3 inclusive in their entirety.

F. SC-2.06

1. Under paragraph 2.06, change "paragraph 2.05.A " to "paragraph 2.07".

G. SC-2.07

1. Delete paragraph 2.07 in its entirety and substitute the following:

2.07 Prior to submission of the first Application for Payment, but no later than 30 calendar days after Contract Times commence, Contractor shall submit to Engineer for review and approval:

- A. A progress schedule indicating the times (numbers of days or dates) for starting and completing the various stages of the Work, including any Milestones specified in the Contract Documents;
- B. A schedule of Shop Drawings and Sample submittal which will list each required submittal and the times for submitting, reviewing, and processing such submittal;
  1. The schedule for shop drawings shall show all submittals complete before 25 percent of Contract Price has been paid to Contractor.
  2. The schedule for maintenance manuals shall show all submittals complete before 50 percent of Contract Price has been paid to Contractor.

3. Failure to meet either of these milestones will result in all future Pay Application Payments being delayed until such time as the milestone has been met in the opinion of the Engineer.

C. A schedule of values for all of the Work which will include quantities and prices of items aggregating the Contract Price and will subdivide the Work into component parts in sufficient detail to serve as the basis for progress payments during construction. Such prices will include an appropriate amount of overhead and profit applicable to each item of Work; and

D. A schedule of progress payments Contractor anticipates will be earned during the course of the Work.

No progress payment shall be made to Contractor until the schedules are submitted to and acceptable to Engineer as provided below. The progress schedule will be acceptable to Engineer as providing an orderly progression of the Work to completion within any specified Milestones and the Contract Times, but such acceptance will neither impose on Engineer responsibility for the sequencing, scheduling or progress of the Work nor interfere with or relieve Contractor from Contractor's full responsibility therefor. Contractor's schedule of Shop Drawing and Sample submissions will be acceptable to Engineer as providing a workable arrangement for reviewing and processing the required submittals. Contractor's schedule of values will be acceptable to Engineer as to form and substance.

1.4 ARTICLE 4 - AVAILABILITY OF LANDS; SUBSURFACE AND PHYSICAL CONDITIONS; REFERENCE POINTS

A. SC-4.01.A  
1. Under paragraph 4.01.A, third sentence, insert the words "and temporary construction easements shown on the Drawings" after the word "facilities".

B. SC-4.02.A  
1. Delete paragraph 4.02.A in its entirety and replace it with the following:  
A. Reports and Drawings:  
1. Section 00 31 32.13 identifies those reports known to Owner of explorations and tests of subsurface conditions at or contiguous to the Site; and  
2. The Supplementary Conditions identify those drawings known to Owner of physical conditions relating to existing surface or subsurface structures at the Site (except Underground Facilities).

C. SC-4.02.B  
1. Under paragraph 4.02.B, delete the second sentence "Such technical data is identified in the Supplementary Conditions".



D. SC-4.02.C

1. Immediately after subparagraph 4.02.B, 3. add the following:

C. The following are drawings of physical conditions relating to existing surface or subsurface structures at the Site (except Underground Facilities) known to Owner:

1. **1986 Well No. 26 Pump Station, Reservoir and Elevated Tank Drawings**

Drawings dated **10/24/1986**

Prepared by **Strand Associates, Inc.**

Drawings titled **Well No. 26 Pump Station, Reservoir and Elevated Tank**

Project No. **20-042**

Owner **Madison Water Utility**

Sheets **Consisting of 11 sheets numbered Sheet 1 to 11 inclusive.**

2. None of the contents of such drawings include technical data on which Contractor may rely.

A. The reports and drawings identified above are not part of the Contract Documents, but the “technical data” contained therein upon which Contractor may rely, as expressly identified and established above, are incorporated in the Contract Documents by reference. Contractor is not entitled to rely upon any other information and data known to or identified by Owner or Engineer.

B. Electronic copies of drawings identified in SC 4.02.C that are not included with the Bidding Documents may be requested from Baxter & Woodman, Inc., 8678 Ridgefield Road, Crystal Lake, IL 60012 during regular business hours.

D. SC-4.03

1. Delete paragraph 4.03A in its entirety and substitute the following:

A. Notification by Contractor, and processing by the Engineer and Owner of Contractor’s claims of differing site conditions shall be done in conformance with P.A. 91-0647.

E. SC-4.05.A

1. Under paragraph 4.05.A., delete first sentence and substitute the following:

A. Owner shall provide land surveys necessary to establish right-of-way, easements and property lines. Engineer will provide base lines, bench

marks and reference points which in Engineer's judgment are necessary to enable Contractor to proceed with the Work. Contractor shall provide all stakes, markers, labor and assistance required by Engineer.

- 2. Under paragraph 4.05.A, last sentence, insert the words "and pay" between the words "responsible" and "for".

1.5 ARTICLE 6 - CONTRACTOR'S RESPONSIBILITIES

A. SC-6.02.B

- 1. Under paragraph 6.02.B, add: The regular working hours are between 7:00 AM and 5:00 PM, Monday through Friday. In the event Contractor works more than eight hours on any weekday, or works anytime on Saturdays, Sundays, or holidays, during which time the Engineer, Resident Project Representative, or assistants are required to be present, Owner shall pay the cost for such overtime engineering services and shall deduct such cost from payments due Contractor. Overtime engineering services shall be charged at Engineer's standard hourly rates applied on a time and one-half basis for all time over eight hours on any single working day and for all hours on Saturday, and on a double time basis for all Sunday and holiday hours. If the amount due Contractor is not sufficient to cover the cost of overtime engineering services, Contractor shall reimburse Owner in the amount necessary to cover such costs. Legal holidays include:

- New Year's Day
- Independence Day
- Thanksgiving Day
- Day after Thanksgiving Day
- Martin Luther King, Jr. Day
- Memorial Day
- Labor Day
- Christmas Day

If the legal holiday falls on Saturday, all hours worked on the preceding Friday and/or the Saturday will be considered as holiday hours. If the legal holiday falls on Sunday, all hours worked on the following Monday will be considered as holiday hours.

B. SC-6.06.A

- 1. Under paragraph 6.06.A, add: Any person employed by Contractor or Subcontractors who does not perform his work in a proper and skillful manner, or who is intemperate, disorderly, or otherwise objectionable, shall, at the written request of Owner, be forthwith removed from the project site and shall not be employed again in any portion of the Work without written consent of Owner.

C. SC-6.06.B

- 1. Under paragraph 6.06.B, add: Contractor shall identify all Subcontractors, major Suppliers and other persons or organizations providing principal items of work, material, and equipment. Contractor shall within ten working days of the date on the Notice of Award identify and submit in writing to the Engineer for Owner acceptance the names, addresses, and telephone numbers of all Subcontractors, Major Suppliers, and other persons or organizations providing principal items of work, material, and equipment.

D. SC-6.19.A

1. Delete paragraph 6.19.A in its entirety and substitute the following:

6.19.A Contractor shall execute and deliver to Owner, before the final payment will be issued, a written warranty which guarantees that all work is in accordance with the Contract Documents and will not be defective. This warranty shall guarantee all work for a period of three years from the date of acceptance of the Work and final payment by Owner, except for equipment, motors, electrical controls, and other mechanical devices which shall be guaranteed for a period of two years from the date of acceptance and use of each item of equipment by Owner unless a different guarantee period of time is specified under other parts of the Contract Documents.

If within these guarantee periods or such longer period of time as may be prescribed by the Contract Documents, any work is found to be defective, Contractor shall promptly, without cost to Owner and in accordance with Owner's written instructions, either correct such defective work, or, if it has been rejected by Owner, remove it from the site and replace it with nondefective work. If Contractor does not promptly comply with the terms of such instructions, or in an emergency where delay would cause serious risk of loss or damage, Owner may have the defective work corrected or the rejected work removed and replaced, and all direct and indirect costs of such repair and/or replacement of work, including compensation for additional professional services, shall be paid or reimbursed to Owner by Contractor.

Contractor shall furnish a warranty bond in an amount equal to five percent (5%) of the Contract Price, but not less than \$10,000, by a surety satisfactory to Owner to guarantee Contractor's warranty to repair or replace defective work. The warranty bond shall be in addition to Contractor's contract Performance-Payment Bond, and shall be delivered to Owner prior to final payment to Contractor for the Work.

E. SC-6.20.A

1. Under paragraph 6.20.A, add:

In addition, Contractor shall indemnify, hold harmless, and pay for the defense of Owner and Engineer from and against claims, losses, or damages in regard to any act or failure to act by Owner or Engineer in connection with general supervision, observation and/or coordination of Contractor's operations.

Contractor shall, at its own expense, appear, defend, and pay all fees of attorneys and all costs and other expenses arising therefrom or incurred in connection therewith; and, if any judgments shall be rendered against any individual or entity indemnified hereunder in any such action, Contractor shall, at its own expense, satisfy and discharge same. Contractor expressly understands and agrees that any Letter of Credit or insurance protection required by the Contract, or otherwise provided by Contractor, shall in no way limit the responsibility to indemnify, keep, and save harmless, and defend any individual or entity indemnified hereunder as herein provided.

- F. SC-6.20.C-E.
  - 1. Delete paragraphs 6.20.C.1 and 6.20.C.2 and replace them with new paragraphs 6.20.C.1, D, and E.:
    - 1. The preparation of Drawings, Specifications, or Property Surveys.
  - D. For any matter for which Owner and Engineer are indemnified under Paragraph 6.20.A, Contractor shall pay for Owner's and Engineer's reasonable defense, including, but not limited to, all fees and charges of engineers, architects, attorneys, and other professionals and all court or arbitration or other dispute resolution costs or awards until Owner or Engineer are found negligent. If Owner or Engineer are found negligent, Owner or Engineer shall reimburse Contractor for the prorata extent of Owner's or Engineer's negligence for the cost of Owner's or Engineer's reasonable defense.
  - E. In Paragraphs 6.20.A. through D. as may be amended by the Supplementary Conditions, Engineer shall also include:
- G. SC-6.21
  - 1. Under paragraph 6.21, add two new subparagraphs:
    - F. The design professional providing the design calculations and design drawings shall be licensed in the State of Wisconsin.
    - G. The design calculation and design drawings are not shop drawings, but shall be submitted to Engineer separately along with the required shop drawings for the system, material, or equipment specified. These calculations will be forwarded to Owner for its records.

1.6 ARTICLE 8 - OWNER'S RESPONSIBILITIES

- A. SC-8.06
  - 1. Delete paragraph 8.06 in its entirety.

1.7 ARTICLE 9 - ENGINEER'S STATUS DURING CONSTRUCTION

- A. SC-9.03
  - 1. Under the paragraph 9.03.A., delete the second sentence.
  - 2. Under paragraph 9.03A add the following:

A LISTING OF THE DUTIES, RESPONSIBILITIES AND LIMITATIONS OF AUTHORITY OF THE RESIDENT PROJECT REPRESENTATIVE (RPR).

**A. General**

RPR is Engineer's agent at the site, will act as directed by and under the supervision of Engineer, and will confer with Engineer regarding RPR's dealings in matters pertaining to the on-site work shall in general be with

Engineer and Contractor keeping Owner advised as necessary. RPR's dealings with subcontractors will only be through or with the full knowledge and approval of Contractor. RPR shall generally communicate with Owner with the knowledge of and under the direction of Engineer.

## **B. Duties and Responsibilities of RPR**

1. *Schedules:* Review the progress schedule, schedule of the Shop Drawing submittals and schedule of values prepared by Contractor and consult with Engineer concerning acceptability.
2. *Conferences and Meetings:* Attend meetings with Contractor, such as preconstruction conferences, progress meetings, job conferences and other project-related meetings, and prepare and circulate copies of minutes thereof.
3. *Liaison:*
  - a. Serve as Engineer's liaison with Contractor, working principally through Contractor's superintendent and assist in understanding the intent of the Contract Documents; and assist Engineer in serving as Owner's liaison with Contractor when Contractor's operations affect Owner's on-site operations.
  - b. Assist in obtaining from Owner additional details or information, when required for proper execution of the Work.
4. *Shop Drawings and Samples:*
  - a. Record date of receipt of Shop Drawings and samples.
  - b. Receive samples which are furnished at the site by Contractor, and notify Engineer of availability of samples for examination.
  - c. Advise Engineer and Contractor of the commencement of any Work requiring a Shop Drawing or sample if the submittal has not been approved by Engineer.
5. *Review of Work, Rejection of Defective Work, Inspections and Tests:*
  - a. Conduct on-site observations of the Work in progress to assist Engineer in determining if the Work is in general proceeding in accordance with the Contract Documents.
  - b. Report to Engineer whenever RPR believes that any Work is unsatisfactory, faulty or defective or does not conform to the Contract Documents, or has been damaged, or does not meet the requirements of any inspection, test or approval required to be made: and advise Engineer of Work that RPR believes should be corrected or rejected or uncovered for observation, or requires special testing, inspection and approval.
  - c. Verify that tests, equipment and systems startups and operating and maintenance training are conducted in the presence of appropriate personnel and that Contractor maintains adequate records thereof; and observe, record and

- report to Engineer appropriate details relative to the test procedures and startups.
- d. Accompany visiting inspectors representing public or other agencies having jurisdiction over the Project, record the results of these inspections and report to Engineer.
6. *Interpretation of Contract Documents:* Report to Engineer when clarifications and interpretations of the Contract Documents are needed and transmit to Contractor clarifications and interpretations as issued by Engineer.
  7. *Modifications:* Consider and evaluate Contractor's suggestions for modifications in Drawings or Specifications and report with RPR's recommendations to Engineer. Transmit to Contractor decisions as issued by Engineer.
  8. *Records:*
    - a. Maintain at the job site orderly files for correspondence, reports of job conference, Shop Drawings and samples, reproductions of original Contract Documents including all Work Directive Changes, Addenda, Change Orders, Field Orders, additional Drawings issued subsequent to the execution of the Contract, Engineer's clarifications and interpretations of the Contract Documents, progress reports, and other Project related documents.
    - b. Complete a Daily Report recording Contractor hours on the job site, weather conditions, data relative to questions or Work Directive Changes, Change Orders or changed conditions, list of job site visitors, daily activities, decisions, observations in general, and specific observations in more detail as in the case of observing test procedures; and send original to Engineer.
    - c. Record names, address and telephone numbers of all Contractors, subcontractors and major suppliers of materials and equipment.
  9. *Reports:*
    - a. Furnish Engineer periodic reports as required of progress of the Work and the Contractor's compliance with the progress scheduled and schedule of Shop Drawings and sample submittals.
    - b. Consult with Engineer in advance of schedule major tests, inspections or start of important phases of the Work.
    - c. Draft Field Orders, obtain backup material from Contractor and recommend to Engineer Change Orders and Work Directive Changes. Furnish Engineer copies of all Field Orders.
    - d. Report immediately to Engineer and Owner upon occurrence of any accident.

10. *Payment Requests:* Review applications for payment with Contractor for compliance with the established procedure for their submission and forward with recommendations to Engineer, noting particularly the relationship of the payment requested to the schedule of values. Work completed and materials and equipment delivered at the site but not incorporated in the Work.
11. *Certificates, Operation and MAINTENANCE Manuals:* During the course of the Work, verify that certificates, operation and maintenance manuals and other data required to be assembled and furnished by Contractor are applicable to the items actually installed and in accordance with the Contract Documents, and have this material delivered to Engineer for review and forwarding to Owner prior to final payment for the Work.
12. *Completion:*
  - a. Before Engineer issues a Certificate of Substantial Completion, prepare and furnish to the Engineer a list of observed items requiring completion or correction.
  - b. Conduct final inspection in the company of Engineer, Owner, and Contractor and prepare and furnish to the Engineer a final list of items to be completed or corrected.
  - c. Observe that all items on final list have been completed or corrected and make recommendations to Engineer concerning acceptance.

**C. Limitations of Authority**

Resident Project Representative:

1. Shall not authorize any deviation from the Contract Documents or substitution of materials or equipment, unless authorized by Engineer.
2. Shall not exceed limitations of Engineer's authority as set forth in the Agreement or the Contract Documents.
3. Shall not undertake any of the responsibilities of Contractor, subcontractors or Contractor's superintendent.
4. Shall not advise on, issue directions relative to or assume control over any aspect of the means, methods, techniques, sequences or procedures or construction unless such advice or directions are specifically required by the Contract Documents.
5. Shall not advise on, issue directions relative or assume control over safety precautions and programs in connection with the Work.

- 6. Shall not accept Shop Drawing or sample submittals from anyone other than Contractor.
- 7. Shall not authorize Owner to occupy the Project in whole or in part.
- 8. Shall not participate in specialized field or laboratory tests or inspections conducted by others except as specifically authorized by Engineer.

1.8 ARTICLE 12 - CHANGE OF CONTRACT PRICE; CHANGE OF CONTRACT TIMES

A. SC-12.04 through 12.06

- 1. Add the following paragraphs:

12.04 Start and Completion Times:

The date of beginning and the time for completion of the Work are essential conditions of the Agreement and the Work required shall be commenced on a date specified in the Notice to Proceed.

12.05 Time for Completion:

Contractor shall proceed with the Work at such rate of progress to insure full completion within the Contract Times. It is expressly understood and agreed, by and between the Contractor and the Owner, that the Contract Times for the completion of the Work described herein is a reasonable time, taking into consideration the adverse weather conditions for the season, or seasons, involved and other factors prevailing in the locality of the Work.

The Contract Substantial Completion date is September 30, 2018. The Contract Final Completion date is October 31, 2018.

12.06 Liquidated Damages:

Contractor understands that time is of the essence and that Owner will suffer financial loss if the Work is not completed within the times or by the dates specified in the Bid Form, plus any extensions thereof allowed in accordance with Article 12 of the General Conditions. Contractor also recognizes the delays, expense, and difficulties involved in proving in a legal or arbitration proceeding the actual loss suffered by Owner if the Work is not completed on time. Accordingly, instead of requiring any such proof, Contractor shall pay Owner as liquidated damages for delay (but not as a penalty) the amount established by the City of Madison General Conditions for each day that expires after the time or date specified above for Substantial Completion until the Work is substantially complete. After Substantial Completion, if Contractor shall neglect, refuse or fail to complete the remaining Work within the Contract Time or any proper extension thereof granted by Owner, Contractor shall pay Owner liquidated damages for delay (but not as a penalty) the amount established by the City of Madison General Conditions for each day that expires after the time or date specified for Final Completion including readiness for final payment.



1.9 ARTICLE 13 - TESTS AND INSPECTIONS; CORRECTION, REMOVAL OR ACCEPTANCE OF DEFECTIVE WORK

A. SC-13.10

1. Add new paragraph 13.10 as follows:

13.10 Notification and Time Limit for Repairs:

- A. Contractor shall be responsible for the proper and safe protection of his work at all times during construction and also during the three-year guarantee period after the acceptance of the completed work by Owner. Contractor shall provide, erect, and maintain barricades, red flags, and torches and lights at all places where work is in progress, and wherever else required by Owner.
- B. Contractor shall maintain an emergency phone number where he/she can be notified at any time, Sundays and holidays included, of an emergency condition due to the work which requires immediate repair or protection. Upon such notification by Owner, Contractor shall be given a two-hour time limit to provide whatever barricades, flags, torches and lights are required to mark and protect the hazard. If Contractor fails to provide this protection within the two-hour period from time of notification, Owner will provide the necessary protection and deduct the sum of \$200.00 for each occurrence from the monies due and payable to Contractor for completed work.
- C. Also, upon notification by Owner, Contractor shall be given a 24-hour time limit to begin to make any repairs to the Work as deemed necessary by Owner. If Contractor fails to proceed with necessary repairs within the 24-hour notification period, Owner will make the necessary repairs to the Work and deduct the cost of labor and materials, including engineering costs, for each repair incident from the monies due and payable to Contractor for completed work.

1.10 ARTICLE 14 - PAYMENTS TO CONTRACTOR AND COMPLETION

A. SC-14.01

1. Add the following paragraph after paragraph 14.01.A:

- B. Contractor shall submit revisions to the initial schedule of progress payments whenever actual outlays for the Work vary beyond -5 percent and +10 percent from the schedule, as determined by Engineer.

B. SC-14.02

1. Under paragraph 14.02.A.1, delete the remainder of the first sentence after "(but not more than one a month)" and insert the following:  
Contractor shall submit to Engineer for review an original plus four duplicate copies of each Application for Payment and each copy shall be accompanied by a "Sworn Statement For Contractor And Subcontractor To Owner" on a pre-printed or computer generated form similar to Certificate 00 62 76.01.

- 2. Delete paragraph 14.02.A.3, and substitute the following:  
 Periodic partial payments shall be for the value of the completed work less a retained amount of 5 percent of the value of completed work as approved by Engineer until construction is 50 percent complete, after which no additional amount will be retained if Contractor is making progress to Owner's satisfaction and there is no specific cause for withholding 5 percent of the total value of completed work. At 50 percent completion or any time thereafter when the progress of the work is not satisfactory, additional amounts may be retained up to 10 percent of the value of the work completed. When the project is substantially complete and available for Owner's operational or beneficial occupancy, the retained amount shall be reduced to only that amount estimated by Engineer as necessary to assure completion of the Work, unless, in the opinion of the Engineer and Owner, Substantial and Final Completion will not be achieved by the designated completion dates established by the Notice to Proceed, as described by Article 12.06 of the Supplementary Conditions. The final payment, including the retained amount, shall be payable within 30 days after the completion of the Work, approval by Engineer and acceptance by Owner. The acceptance of the final payment by Contractor shall be considered to be a waiver of all claims against Owner under the Agreement.

- C. SC-14.02.C
  - 1. Under paragraph 14.02.C, change "Ten" to "Within 30".

- D. SC-14.03
  - 1. Under paragraph 14.03.A, add the following:
    - B. Contractor shall procure from each Subcontractor and Supplier of material or labor a waiver of any claim which they may have under the mechanics lien laws of the state in which the Work is located, to insure Owner immunity from mechanics liens on account of anything which is done by Contractor or his Subcontractors in carrying out the Agreement and any work orders for additions thereto, all as a condition of any payment by Owner. Any payments made by Owner without requiring compliance with this paragraph shall not be construed as a waiver by Owner of the right to require compliance with this paragraph as a condition of later payments. Contractor shall furnish with his final Application for Payment a complete release of all liens arising out of this contract, or receipts in full in lieu thereof and an affidavit that the releases and receipts include all labor and material for which a lien could be filed.

- E. SC-14.07
  - 1. Under paragraph 14.07.C, change "Thirty" to "Sixty".

1.11 ARTICLE 19 – PREVAILING WAGE RATES

- A. SC-19.01 Prevailing Wage Rates
  - 1. Prevailing wage rates will not apply to this project.

END OF SUPPLEMENTARY CONDITIONS

SECTION 01 14 11

CONTRACTOR USE OF PREMISES

PART 1 - GENERAL

1.1 SUMMARY

- A. This Section applies to all situations in which the Contractor or his representatives including, but not necessarily limited to, suppliers, subcontractors, employees, and field engineers, enter upon the Owner's property.
- B. Related work:
  - 1. Documents affecting work of this Section include, but are not necessarily limited to, General Conditions, Supplementary Conditions, and Division 01 - General Requirements of these Specifications.
- C. References:
  - 1. Reserved.

1.2 SUBMITTALS

- A. Shop Drawing Submittals – None Required.
- B. Operation and Maintenance Manuals – None Required.
- C. Certificates and Guarantees – None Required.
- D. Lubricants – None Required.
- E. Spare Parts – None Required.
- F. Provide a list of names and identification of all persons to be entering the Owner's property in connection with the Work of this Contract, and submit a copy of the list to the Owner at the preconstruction conference.
  - 1. Advise the Owner of personnel changes at project meetings.

1.3 QUALITY ASSURANCE

- A. Promptly upon award of the Contract, notify all pertinent personnel regarding requirements of this Section.
- B. Require that all personnel who will enter upon the Owner's property certify their awareness of and familiarity with the requirements of this Section.

1.4 DELIVERY, STORAGE, AND HANDLING

- A. Do not store construction equipment, tools or materials on any area of the Owner's property except where shown on the Drawings as the "Contractor's Storage Area," or where otherwise directed by the Engineer.

CONTRACTOR USE OF PREMISES

01 14 11-1 (150826.40)

1.5 SITE CONDITIONS – Reserved.

1.6 NOISE CONTROL

- A. Conduct operations to cause the least annoyance to residents in the vicinity of the Work and comply with City of Madison Ordinances.
- B. Work hours shall be between 7 AM and 7 PM, Monday through Saturday, except legal holidays observed by Owner and unless otherwise agreed to in writing from Owner.
- C. Equip all mechanical devices and engines with adequate silencers and mufflers.

1.7 USE AND RESTORATION OF THE SITE

- A. Construct and maintain temporary roadways from the existing public roadway to the site and within the entire site for material and equipment transport necessary to complete the work.
  - 1. Include necessary culverts for proper drainage.
  - 2. Obtain necessary permits for the construction of access temporary roadways.
  - 3. Obtain Engineer's approval for the location of the temporary roadways.
- B. Upon completion of the Work, restore areas used for temporary roadways to fully graded condition totally free of stones or crushed rock.
- C. Before submitting Final Application for Payment, restore all areas within the work site boundaries disturbed by the Work to a fully regraded condition, provided with at least four (4) inches of hand raked topsoil and seeded as specified under Section 32.92.00.13.
- D. Clean all permanent roadways used for construction activities by using motorized street sweeper that utilizes vacuum and water to pick up debris, at end of every day, as necessary.

1.8 CONTRACTOR'S INGRESS AND EGRESS

- A. Truck and Equipment access:
  - 1. Limit the access of trucks and equipment to the route shown on the Drawings as "Access Route" or where otherwise directed by the Engineer.
  - 2. Provide adequate protection for curbs and sidewalks over which trucks and equipment pass to reach the work site.
- B. Contractor's vehicles:
  - 1. Require Contractor's vehicles, vehicles belonging to employees of the Contractor, and all other vehicles entering upon the Owner's property in performance of the Work, to use only the Access Route shown on the Drawings, or as authorized by the Engineer.
  - 2. Do not permit such vehicles to park on any street or other area of the Owner's property except where authorized by the Engineer.

CONTRACTOR USE OF PREMISES

01 14 11-2 (150826.40)

- C. Restoration: Clean and restore to at least the preconstruction condition for all roadways, streets, sidewalks, driveways, and parking areas used during construction.

#### 1.9 ACCESS TO OWNER'S FACILITIES

- A. Restricted areas and structures:
  - 1. Do not enter any designated restricted area or any existing structure, except as required to do specific work.
  - 2. Obtain Owner's permission to enter restricted areas or existing structures to do specific work.
  - 3. Remove all construction debris and clean work areas daily when working in restricted areas or existing structures.
- B. Equipment:
  - 1. Do not use Owner's equipment or tools.

#### 1.10 PROTECTION OF EXISTING PROPERTY AND EQUIPMENT

- A. Property:
  - 1. Receive permission to remove existing brush-line along Old Sauk Road.
  - 2. Take all necessary precautions to protect existing structures, piping, trees and all other facilities from damage during construction, and comply with Section 31 23 79, paragraph 3.2 of these Specifications.
  - 3. Repair or replace all property damaged during construction.
- B. Equipment:
  - 1. Take all necessary precautions to protect all equipment from sand, dust, water and other debris which is produced during construction.
  - 2. Wherever possible, cut concrete or masonry from outside the structure to prevent production of dust in areas containing equipment.
  - 3. During dust-producing activities inside of structures, isolate work area from equipment using temporary impervious partitions or individual equipment encasement.
  - 4. Under excessive dust conditions, ventilate isolated working areas as directed by Engineer.
  - 5. Remove all temporary equipment protection facilities upon completion of construction activity requiring such protective measures.

#### 1.11 DISPOSAL OF SPOIL

- A. Remove all spoil, excess excavated material, or other construction activity residual materials from the work site. Do not deposit this material on private or public property without written permission from property owner or authorized representative of the appropriate public agency.

#### 1.12 SECURITY

- A. Restrict the access of all persons entering upon the Owner's property in connection with the Work to the Access Route and to the actual site of the Work.

END OF SECTION

CONTRACTOR USE OF PREMISES

01 14 11-3 (150826.40)

## SECTION 01 26 13

### REQUESTS FOR INTERPRETATION

#### PART 1 - GENERAL

##### 1.1 SUMMARY: REQUESTS FOR INTERPRETATION (RFI)

- A. The Contractor may submit Requests For Interpretation (RFI) to the Engineer to expedite the Contractor's performance on the Project. RFIs will be submitted following the requirements, all as described in this Section.
- B. Related work:
  - 1. Documents affecting work of this Section include, but are not necessarily limited to, General Conditions, Supplementary Conditions, and Sections in Division 01 of these Specifications.
  - 2. Individual requirements for submittals will be described in pertinent Sections of these Specifications.
- C. Work not included:
  - 1. Incomplete submittals will not be reviewed by the Engineer.
  - 2. The Contractor may require his subcontractors to provide drawings, setting diagrams, and similar information to help coordinate the Work, but such data shall remain between the Contractor and his subcontractors and will not be reviewed by the Engineer unless specifically called for within the Contract Documents.

##### 1.2 SUBMITTALS

- A. Make submittals of RFIs in accordance with the provisions of this Section.
- B. Prior to submitting each RFI, the Contractor shall first carefully study and compare the Contract Documents, field conditions, other Owner provided information, Contractor prepared Coordination Drawings, and prior Project correspondence and documentation to determine that the information requested is not reasonably obtainable from such sources.
- C. The Contractor shall submit each RFI sufficiently in advance of the date by which such information is required to allow the Engineer sufficient time, in the Engineer's professional judgement, to permit adequate review and response and to permit Contractor compliance with the latest construction schedule.

#### PART 2 - PRODUCTS

This Subsection intentionally left blank.

### REQUESTS FOR INTERPRETATION

01 26 13-1 (150856.40)

## PART 3 - EXECUTION

### 3.1 IDENTIFICATION OF SUBMITTALS

- A. Each RFI shall be submitted to the Engineer, in writing, on such form and with such accompanying information as the Engineer may require for such purpose. Each RFI shall identify the specific sources which were reviewed by the Contractor in its efforts to determine the information requested, and a statement to the effect that the information being requested could not be determined from such sources.
- B. Consecutively number all submittals.
  - 1. When material is submitted for any reason, transmit under a new letter of transmittal and with a new transmittal number.
  - 2. On re-submittals, cite the original submittal number for reference.
- C. Accompany each submittal with a letter of transmittal showing all information required for identification and checking.
  - 1. Use Request for Interpretation (RFI) Form, RFI 01 26 13.13-1.
- D. On at least the first page of each submittal, and elsewhere as required for positive identification, show the submittal number in which the item was included.
- E. Submittal log:
  - 1. Maintain an accurate submittal log for the duration of the Work, showing current status of all submittals at all times, the date of the request, to whom the request was made, by whom the request was made, the nature of the request, and the Engineer's resolution thereof.
  - 2. Make the submittal log available to the Engineer for the Engineer's review upon request.
  - 3. Review this log at each Project Meeting and make the resolution of RFIs a part of the minutes of such meetings.

END OF SECTION

01 26 13.13

REQUEST FOR INTERPRETATION (RFI) FORM

RFI NO. \_\_\_\_\_

Contractor requests for interpretation will be considered upon receipt of this completed RFI Form. By submission of this form the Contractor attests to the fact that having carefully reviewed the Contract Documents and coordinated the Work with the appropriate trades and reviewed field conditions, that the information requested cannot be determined from such efforts as called for in the General Conditions of the Contract.

Date: \_\_\_\_\_ Project: \_\_\_\_\_

To: \_\_\_\_\_

Description of Requested Interpretation: \_\_\_\_\_

\_\_\_\_\_

\_\_\_\_\_

Specification References: \_\_\_\_\_

Drawing References: \_\_\_\_\_

Proposed method of resolving issue.      Sketches and/or Pages Attached: \_\_\_\_\_ Yes, \_\_\_\_\_ No

\_\_\_\_\_

\_\_\_\_\_

Potential impact on project cost: \_\_\_\_\_

Response Date: \_\_\_\_\_ List date by which response by Engineer is requested to maintain project schedule. (Allow sufficient time for response).

Signed: \_\_\_\_\_, Project Superintendent  
Signature signifies acceptance of responsibility for accuracy and completeness of information.

ENGINEER'S RESPONSE

Notations listed below indicate the Engineer's action on method proposed by the Contractor to resolve issues or remarks in response to RFI when no Contractor recommendation has been provided. Changes to Contract Amount and/or project time shall be processed using standard Change Order Forms.      Sketches and/or Pages Attached \_\_\_\_\_ Yes \_\_\_\_\_ No

\_\_\_\_\_

\_\_\_\_\_

Signed: \_\_\_\_\_ Date: \_\_\_\_\_



## SECTION 01 31 14

## PROJECT COORDINATION AND CONSTRUCTION PHASING

## PART 1 - GENERAL

## 1.1 SUMMARY

- A. This section describes the Contractor's general project coordination and construction phasing requirements under this Contract.
- B. Related work:
  - 1. Documents affecting work of this Section include, but are not necessarily limited to, General Conditions, Supplementary Conditions, and Sections in Division 01 and Division 02 of these Specifications.
- C. Coordinate construction activities with the Owner and Engineer.
- D. Follow specific procedures and project phasing requirements specified in this Section.
- E. Submit the plan of construction phasing to the Owner and Engineer for review two working days prior to the pre-construction conference.

## 1.2 SUBMITTALS

- A. Submit a detailed plan for phasing of construction in all areas and phasing of construction and restoration that will illustrate compliance with project phase completion requirements.
  - 1. Define construction activities on a week-by-week basis.
  - 2. Allow for reasonable periods of delays caused by inclement weather.
- B. Define Contractor's plans regarding storage and staging areas.
  - 1. Include property owner representative's name and phone number.
  - 2. Outline requirements of agreement.
  - 3. Define means to be utilized to meet agreements, including security measures and restoration methods.
- C. Submit a detailed plan that indicates the methods and materials that are to be utilized for sewer testing and temporary street patching.
  - 1. Submit plan at pre-construction meeting for approval by Owner and Engineer.
  - 2. Revise plan, methods, and materials to comply with comments by Owner and Engineer.

## PROJECT COORDINATION AND CONSTRUCTION PHASING

01 31 14-1 (150826.40)

### 1.3 CONTRACTOR'S REQUIREMENTS

- A. Project Completion: Prepare and maintain a sequence of construction activities with overall Project Completion as established in Item 1.8 A. 1., of these Supplementary Conditions.
- B. Utility Installation: Coordinate Electrical Service installation to meet Project Completion dates and coordinate with MWU for water main installation.
- C. Access Road Construction: Coordinate temporary and final access road construction. Receive permission to remove shrubs and trees along Old Sauk Road fenceline prior to construction activities.
- D. Seeding: Coordinate seeding to limit amount of and duration of time that soils will remain unseeded and exposed to erosion.
- E. Elevated Tank 126: Installation of new altitude valve and modifications to riser pipe will need to occur after Blackhawk Water Tower is successfully put on line. Contractor to disinfect Elevated Tank 126 after completion of tank modifications.

### PART 2 - PRODUCTS

No products are required in this Section.

### PART 3 - EXECUTION

#### 3.1 INSTALLATION

- A. Construct the proposed facilities in a timely manner and comply with these project coordination and construction phasing requirements.

END OF SECTION

SECTION 01 31 19  
PROJECT MEETINGS

PART 1 - GENERAL

1.1 DESCRIPTION

- A. Work included: To enable orderly review during progress of the Work, and to provide for systematic discussion of problems, the Engineer will conduct project meetings throughout the construction period.
- B. Related work:
  - 1. Documents affecting work of this Section include, but are not necessarily limited to, General Conditions, Supplementary Conditions, and Division 01 – General Requirements of these Specifications.
  - 2. The Contractor's relations with his subcontractors and materials suppliers, and discussions relative thereto, are the Contractor's responsibility and normally are not part of project meetings content.

1.2 SUBMITTALS

- A. Agenda items: To the maximum extent practicable, advise the Engineer at least 24 hours in advance of project meetings regarding items to be added to the agenda.
- B. Minutes:
  - 1. The Engineer will compile minutes of each project meeting, and will furnish three copies to the Contractor and required copies to the Owner.
  - 2. Recipients of copies may make and distribute such other copies as they wish.

1.3 QUALITY ASSURANCE

- A. For those persons designated by the Contractor to attend and participate in project meetings, provide required authority to commit the Contractor to solutions agreed upon in the project meetings.

PART 2 - PRODUCTS

(No products are required in this Section)

PART 3 - EXECUTION

3.1 MEETING SCHEDULE

- A. Project meetings will be scheduled at the Pre-construction Meeting.

- B. Coordinate as necessary to establish mutually acceptable schedule for meetings.

### 3.2 MEETING LOCATION

- A. The Engineer will establish meeting location. To the maximum extent practicable, meetings will be held at the job site.

### 3.3 PRECONSTRUCTION MEETING

- A. Pre-construction Meeting will be scheduled to be held within 20 working days after the effective date of the Agreement.
  - 1. Provide attendance by authorized representatives of the Contractor and major subcontractors.
  - 2. The Engineer will advise other interested parties, including the Owner, and request their attendance.
- B. Minimum agenda: Data will be distributed and discussed on at least the following items:
  - 1. Organizational arrangement of Contractor's forces and personnel, and those of subcontractors, materials suppliers, and Engineer.
  - 2. Channels and procedures for communications.
  - 3. Construction schedule, including sequence of critical work.
  - 4. Contract Documents, including distribution of required copies of original Documents and revisions.
  - 5. Processing of Shop Drawings and other data submitted to the Engineer for review.
  - 6. Processing of Bulletins, field decisions, and Change Orders.
  - 7. Rules and regulations governing performance of the Work; and
  - 8. Procedures for safety and first aid, security, quality control, housekeeping, and related matters.

### 3.4 PROJECT MEETINGS

- A. Attendance:
  - 1. To the maximum extent practicable, assign the same person or persons to represent the Contractor at project meetings throughout progress of the Work.
  - 2. Subcontractors, materials suppliers, and others may be invited to attend those project meetings in which their aspect of the Work is involved.

END OF SECTION

## SECTION 01 32 16

## CONSTRUCTION PROGRESS SCHEDULES

## PART 1 - GENERAL

## 1.1 SUMMARY

- A. Prepare and maintain the schedules and reports described in this Section to assure adequate planning and execution of the Work so that the Work is completed within the Contract Times, and to assist the Engineer in appraising the reasonableness of the proposed schedule and in evaluating progress of the Work.
- B. Related work:
  - 1. Documents affecting work of this Section include, but are not necessarily limited to, General Conditions, Supplementary Conditions, and Division 01 – General Requirements of these Specifications.
  - 2. Requirements for progress schedule: General Conditions.
  - 3. Construction period: Form of Agreement.

## 1.2 SUBMITTALS

- A. Comply with pertinent provisions of Section 01 33 01.
- B. Construction schedule: Prior to submission of the first Application for Payment, but no later than 30 calendar days after Contract Times commence, submit to the Engineer one reproducible copy and four prints of a construction schedule prepared in accordance with Part 3 of this Section.
- C. Periodic reports: Prior to submittal of Application for Payment for completed work coinciding with 50 percent and 80 percent of the Contract Price, submit to the Engineer four prints of the construction schedule updated as described in Part 3 of this Section.

## 1.3 QUALITY ASSURANCE

- A. Perform data preparation, analysis, charting, and updating in accordance with standards approved by the Engineer.
- B. Reliance upon the approved schedule:
  - 1. The construction schedule as approved by the Engineer will be an integral part of the Contract and will establish interim completion dates for the various activities under the Contract.
  - 2. Processing of the first Application for Payment will not be completed by the Engineer until the construction schedule has been submitted in accordance with 1.2 B. above.
  - 3. Processing of the 50 percent and 80 percent progress payment applications will not be completed by the Engineer until the periodic reports have been submitted in accordance with 1.2 C. above.

## CONSTRUCTION PROGRESS SCHEDULES

01 32 16-1 (150826.40)

## PART 2 - PRODUCTS

### 2.1 CONSTRUCTION ANALYSIS

- A. Graphically show by Critical-Path (CPM), Program Evaluation and Review Technique (PERT), Precedence Methods, bar-chart, or other means acceptable to the Engineer, the order and interdependence of all activities necessary to complete the Work, and the sequence in which each activity is to be accomplished, as planned by the Contractor and his project field superintendent in coordination with all subcontractors whose work is shown on the diagram.
- B. Include, but do not necessarily limit indicated activities to:
  - 1. Project mobilization.
  - 2. Work elements.
  - 3. Special material and equipment installation and testing.
  - 4. Final cleanup.
  - 5. Final inspecting and testing.
  - 6. All activities by the Engineer that affect progress, required dates for completion, or both, for all and each part of the work.
  - 7. Contractor's anticipated working dates.

## PART 3 - EXECUTION

### 3.1 CONSTRUCTION SCHEDULE

- A. As soon as practicable after receipt of Notice to Proceed, complete the construction schedule in preliminary form, meet with the Engineer, review contents of the proposed construction schedule, and make all revisions agreed upon.
- B. Submit in accordance with Paragraph 1.2 B. above.

### 3.2 PERIODIC REPORTS

- A. As required under Paragraph 1.2 C. above, update the approved construction schedule.
  - 1. Indicate "actual" progress in percent completion for each activity;
  - 2. Provide written narrative summary of revisions causing delay in the program, and an explanation of corrective actions taken or proposed.

### 3.3 REVISIONS

- A. Make only those revisions to approved construction schedule as are approved in advance by the Engineer.

END OF SECTION

CONSTRUCTION PROGRESS SCHEDULES

01 32 16-2 (150826.40)

## SECTION 01 33 01

## SUBMITTALS

## PART 1 - GENERAL

## 1.1 SUMMARY

- A. Provide submittals required by the Contract Documents, and revise and resubmit as necessary to establish compliance with the specified requirements, all as described in this Section.
- B. Related work:
  - 1. Documents affecting work of this Section include, but are not necessarily limited to, General Conditions, Supplementary Conditions, and Division 01 - General Requirements of these Specifications.
  - 2. Individual requirements for submittals will be described in pertinent Sections of these Specifications.
    - a. The process for securing approval of proposed substitutions is described in Section 01 62 01, "Product Options and Substitutions".
- C. Work not included:
  - 1. Submittals not required by the various Specification Sections of the Contract Documents will not be reviewed by the Engineer.
  - 2. The Contractor may require his subcontractors to provide drawings, setting diagrams, and similar information to help coordinate the Work, but such data shall remain between the Contractor and his subcontractors and will not be reviewed by the Engineer unless specifically called for within the Contract Documents.
- D. References:
  - 1. Reserved.

## 1.2 SUBMITTALS

- A. Provide submittals of Shop Drawings, Samples, Substitution Requests, progress schedules and other items required in the Contract Documents in accordance with the provisions of this Section.

## 1.3 QUALITY ASSURANCE

- A. Coordination of submittals:
  - 1. Review and coordinate all aspects of each item being submitted carefully prior to each submittal.
  - 2. Verify that each item and the submittal for it conform in all respects with the specified requirements.

3. Certify that this coordination has been performed by affixing the Contractor's signature to each Contractor's Submittal Transmittal Form Attachment 01 33 01.

B. Resubmittals and reimbursement of Engineer's costs.

1. The Engineer will record all time used by the Engineer in the review of any third and subsequent submittals.
2. The Owner will reimburse the Engineer at the Engineer's standard hourly rate for all time spent in such third and subsequent reviews and deduct such costs from payments due the Contractor.

1.4 DELIVERY, STORAGE, AND HANDLING – Reserved.

1.5 SITE CONDITIONS – Reserved.

1.6 MAINTENANCE – Reserved.

## PART 2 - PRODUCTS

### 2.1 SHOP DRAWINGS

- A. Provide Shop Drawings accurately to a scale sufficiently large to show all pertinent aspects of the item and its method of connection to the Work.
  1. Shop Drawings are not required for manholes, valve vaults, catch basins, pipe, and appurtenances needed for infrastructure systems (storm sewers, sanitary sewers, and water distribution) so long as the items match the materials and manufacturers specified in the project manual.
- B. Submit Shop Drawings electronically to the Engineer as a single .pdf file set.
  1. Attach, as the first page of each Shop Drawing, a completely executed Contractor's Submittal Transmittal Form Attachment 01 33 01.
  2. Collate the electronic .pdf file to include all data pertaining to the Shop Drawing Submittal in one .pdf set.
    - a. Separate .pdf files submitted will be cause for rejection and the Shop Drawing will be returned to the Contractor.
- C. Submit all required shop drawings for a specification section at the same time under one Contractor's Submittal Transmittal Form Attachment 01 33 01.
- D. Do not submit partial submittals of an item within a specification section or use a separate Contractor's Submittal Transmittal Form Attachment 01 33 01 for separate items within a particular section.
- E. Identify exceptions or items that do not comply with the specifications and provide explanation for exception or non-compliance.



- F. For Shop Drawings required to be resubmitted for review, include the following:
1. A completely executed cover sheet Contractor's Submittal Transmittal Form Attachment 01 33 01.
  2. A cover letter responding to each of the review comments returned to the Contractor by the Engineer with the previous review and specifically stating:
    - a. If the equipment and resubmitted data provided complies with the review comment(s). If so, then the Contractor shall provide:
      - (1) How the equipment complies.
      - (2) Specifically indicate where support documentation can be located in the shop drawing.
    - b. If the equipment and resubmitted data provided cannot or does not comply with the review comment(s). If so, then the Contractor shall provide:
      - (1) What is being provided to comply instead.
      - (2) Justify why the Contractor feels the Engineer should consider it is acceptable not to allow the Contractor to not comply with the specification.
  3. Resubmission of a complete and fully-inclusive shop drawing with all data pertinent to the item(s) being submitted.
    - a. Partial submission of data that only addresses the Engineer's specific review comments, or a portion thereof, and does not include all data for a complete resubmittal, will be cause for immediate rejection.

## 2.2 MANUFACTURERS' LITERATURE

- A. Where contents of submitted literature from manufacturers includes data not pertinent to the submittal, clearly indicate which portion of the contents is being submitted for review by highlighting, circling, or other means, or by crossing out contents that do not pertain to the submittal and are not to be considered.
1. This also applies to specifically indicating, when applicable, which optional items will or will not be provided with items specified.

## 2.3 SAMPLES

- A. Provide Sample or Samples identical to the precise article proposed to be provided.
1. Identify as described under "Identification of submittals" below.
- B. Number of Samples required:
1. Unless otherwise specified, submit Samples in the quantity which is required to be returned, plus one which will be retained by the Engineer.
  2. By prearrangement in specific cases, a single Sample may be submitted for review and, when approved, be installed in the Work at a location agreed upon by the Engineer.
  3. Because submittals are submitted to the Engineer in an electronic format as described herein, specifically indicate on the Contractor's Submittal Transmittal Form Attachment 01 33 01 included with each submittal (when samples are required) when and where the physical samples will or have been transmitted for physical observation.

4. Include as part of the electronic submittal a .pdf copy of any and all transmittals, shipping information, signatures of receipt, etc. identifying the transmission and receipt of the said sample(s).

## 2.4 COLORS AND PATTERNS

- A. Unless the precise color and pattern is specifically called out in the Contract Documents, and whenever a choice of color or pattern is available in the specified products, submit accurate color and pattern charts to the Engineer for selection.

## 2.5 MANUFACTURERS' RECOMMENDED INSTALLATION PROCEDURES

- A. Maintain in a safe place at the site one copy of manufacturers' recommended installation procedures for all equipment and materials.
  1. Make these installation procedures readily available to the Engineer for reference.
- B. When the manufacturers' recommended installation procedures are submitted as part of the shop drawings required by the Contract Documents, approval of such installation procedures by the Engineer will not be required.

## PART 3 - EXECUTION

### 3.1 IDENTIFICATION OF SUBMITTALS

- A. Consecutively number all submittals beginning with identifying number "001" for the first submittal delivered by the Contractor.
  1. When items are submitted for any reason, transmit under a new Contractor's Submittal Transmittal Form Attachment 01 33 01 and with a new transmittal number.
  2. When material is resubmitted for any reason, cite the original identifying submittal number, and followed by insertion of a letter "A" for the first resubmittal, "B" for the second resubmittal, and so on.
- B. Accompany each submittal with a letter of transmittal showing all information required for identification and checking.
  1. Use Contractor's Submittal Transmittal Form, Attachment 01 33 01.
- C. On at least the first page of each submittal, and elsewhere as required for positive identification, show the submittal number in which the item was included.

### 3.2 GROUPING OF SUBMITTALS

- A. Shop Drawings may be submitted for different specification sections under one Contractor's Submittal Transmittal Form Attachment 01 33 01, provided the items are specifically and directly related to each other such that review of the items from different specification sections is pertinent for a complete review.
  1. Identify any and all items and their specific specification section(s) if included with and submitted under a differing main specification section submittal.

2. Partial submittals may be rejected as not complying with the provisions of the Contract.
3. The Contractor may be held liable for delays so occasioned.
4. Do not submit unrelated items in group submittals.

### 3.3 ELECTRONIC SUBMITTAL PROCEDURES

- A. Electronic Submittals:
  1. Transmit submittals to Engineer in electronic (.pdf) format.

### 3.4 TIMING OF SUBMITTALS

- A. Make submittals far enough in advance of scheduled dates for installation to provide time required for reviews, for securing necessary approvals, for possible revisions and resubmittals, and for placing orders and securing delivery.
- B. In scheduling, allow at least ten working days for review by the Engineer following the Engineer's receipt of the submittal.

END OF SECTION

ATTACHMENT 01 33 01

CONTRACTOR'S SUBMITTAL TRANSMITTAL FORM

TO: BAXTER & WOODMAN, INC.  
256 S. PINE STREET  
BURLINGTON, WI 53105

DATE: \_\_\_\_\_

ATTN: \_\_\_\_\_

PROJECT NAME: \_\_\_\_\_

FROM: \_\_\_\_\_ SPEC NO. \_\_\_\_\_

\_\_\_\_\_ ENGR. DWG. NOS. \_\_\_\_\_

\_\_\_\_\_ TRANSMITTAL NO. \_\_\_\_\_

1. The following submittals are forwarded for your review:

<u>No. of Copies</u>	<u>Manufacturer</u>	<u>Description</u>	<u>Drawing No.</u>	<u>Date</u>
_____	_____	_____	_____	_____
_____	_____	_____	_____	_____
_____	_____	_____	_____	_____

2. Have all field measurements, field construction criteria, materials, dimensions, catalog numbers, and similar data been determined and verified? Yes \_\_\_ No \_\_\_\_\_

3. Has work indicated in this submittal been coordinated with all trades? Yes \_\_\_ No \_\_\_\_\_

4. Is work by all trades being provided as necessary to accommodate this submittal? Yes \_\_\_ No \_\_\_\_\_

5. Contractor has approved submittal and has affixed his certification stamp. Yes \_\_\_ No \_\_\_\_\_

6. Contractor's description and justification for deviations from Contract Documents. (Use additional sheet if necessary.)

\_\_\_\_\_  
\_\_\_\_\_  
\_\_\_\_\_

7. Remarks: \_\_\_\_\_

\_\_\_\_\_  
\_\_\_\_\_

Signature:

SECTION 01 41 26

PERMITS

PART 1 - GENERAL

1.1 SUMMARY

- A. This section describes permit requirements for building, work in highway and railroad rights-of way, and environmental permits.
- B. Related sections:
  - 1. Documents affecting work of this Section include, but are not necessary limited to, General Conditions and Supplementary Conditions, and Division 01 – General Requirements of these Specifications.
  - 2. Other permits requirements may also be described in other Sections of these Specifications.

1.2 SUBMITTALS - Reserved.

1.3 QUALITY ASSURANCE

- A. Promptly upon award of the Contract, notify all pertinent personnel regarding requirements of this Section.
- B. Require that all personnel who will enter upon the Owner's property certify their awareness of and familiarity with the requirements of this Section.

1.4 DELIVERY, STORAGE, AND HANDLING – Reserved.

1.5 SITE CONDITIONS – Reserved.

1.6 MAINTENANCE – Reserved.

1.7 BUILDING PERMITS

- A. Obtain all permits required, and pay all inspection fees for the respective work requiring such permits. Madison Water Utility to reimburse Contractor for all regulatory inspection and permit fees.

1.8 WORK IN HIGHWAY RIGHTS-OF-WAY

- A. Conform in all respects with the requirements of the controlling authority in performing construction work in the rights-of-way of Township, County, State, and Federal highways where required by the locations shown on the Drawings.

PERMITS

- B. Execute all necessary highway permit forms, provide and pay for any bond requirements, and execute and comply with any required Traffic Control Authorization Requests.
- C. Notify the highway authority involved not less than ten (10) days prior to starting construction in highway rights-of-way.

1.9 TRENCH DEWATERING

- A. Conform to the Wisconsin Department of Natural Resources (WDNR) Construction Site Best Management Practice Handbook, Technical Standards, and WPDES permit requirements.

1.10 ENVIRONMENTAL PERMITS

- A. Conform to the requirements of the Wisconsin Department of Natural Resources (WDNR) permits.

END OF SECTION

## SECTION 01 42 13

## ABBREVIATIONS AND ACRONYMS

## PART 1 - GENERAL

## 1.1 SUMMARY

- A. This Section describes abbreviations referenced in the Contract Documents.
- B. Related Work:
  - 1. Documents affecting work of this Section include, but are not necessarily limited to, General Conditions, Supplementary Conditions, and Division 01 – General Requirements of these Specifications.

## 1.2 ABBREVIATIONS

- A. Referenced Standards:
  - 1. Where the Contract Documents reference any published specifications or standards of any organization or association, comply with the requirements of the specification or standards which are current on the date of Advertisement for Bids. In case of a conflict between the referenced specifications or standards, the one having the more stringent requirements shall govern.
  - 2. In case of conflict between the referenced specifications or standards and the Contract Documents, the Contract Documents shall govern.
- B. Abbreviations:
  - 1. The following are definitions of abbreviations that may be used within the Project Manual:
    - AA - Aluminum Association
    - AASHTO - American Association of State Highway and Transportation Officials
    - ACI - American Concrete Institute
    - AISC - American Institute of Steel Construction
    - ANSI - American National Standard Institute
    - ASCE – American Society of Civil Engineers
    - ASTM - American Society for Testing and Materials
    - AWG - American Wire Gauge
    - AWS - American Welding Society
    - AWWA - American Water Works Association
    - CBM - Certified Ballast Manufacturers Association
    - CRSI - Concrete Reinforcing Steel Institute
    - ICEA - Insulated Cable Engineers Association
    - IEEE - Institute of Electrical and Electronics Engineers, Inc.
    - ISA - Instrument Society of America
    - FS - Federal Specifications
    - MWU – Madison Water Utility

## ABBREVIATIONS AND ACRONYMS

01 42 13-1 (150826.40)

NEC - National Electrical Code (NFPA 70)  
NECA - National Electrical Contractors' Association  
NEMA - National Electrical Manufacturer's Association  
NFPA - National Fire Protection Association or National Forest Products Association  
NSF - National Sanitation Foundation  
OSHA - U.S. Department of Labor, Occupational Safety and Health Department  
PS - United States Products Standards  
SSPC - Structural Steel Painting Council  
UL - Underwriter's Laboratories, Inc.  
WDOT - "STANDARD SPECIFICATIONS" - Wisconsin Department of Transportation, "STANDARD SPECIFICATIONS for Highway and Structure Construction"

END OF SECTION



## SECTION 01 45 29

## TESTING LABORATORY SERVICES

## PART 1 - GENERAL

## 1.1 SUMMARY

- A. This Section describes testing to be provided by an independent testing laboratory service.
- B. Related work:
  - 1. Documents affecting work of this Section include, but are not necessarily limited to, General Conditions, Supplementary Conditions, and Division 01 – General Requirements of these Specifications.
  - 2. Requirements for specific tests will be described in various Sections of these Specifications.

## 1.2 QUALITY ASSURANCE

- A. Coordinate the services of a testing laboratory approved by the Engineer.
- B. Upon completion of each test and/or inspection, promptly distribute copies of test or inspection reports to the Engineer, to governmental agencies requiring submission of such reports, and to such other persons as directed by the Engineer.

## 1.3 TESTING AGENCY DUTIES AND LIMITS OF AUTHORITY

- A. Cooperate with the Engineer and the Contractor; provide qualified personnel and equipment to perform the scope of testing work outlined.
- B. Acquaint the Engineer and the Contractor with testing procedures for special conditions encountered at the site.
- C. Perform specified monitoring, sampling, and testing of the materials and construction.
  - 1. Comply with specified standards, ASTM, other authorities, and as specified.
  - 2. Ascertain compliance with the Contract Documents.
  - 3. Obtain written acknowledgment of sampling or testing.
- D. Give prompt written notice to the Engineer and the Contractor of irregularities or deficiencies of work which are observed during performance of service.

## TESTING LABORATORY SERVICES

01 45 29-1 (150826.40)

- E. The Laboratory is not authorized to release, revoke, alter or enlarge the Contract requirements, nor to approve or accept any portion of the work, nor to perform the duties of the Contractor.

## PART 2 - PRODUCTS

### 2.1 PAYMENT FOR TESTING

- A. Include within the Contract Price an amount sufficient to cover all testing required of the Contractor under pertinent Sections of these Specifications.
- B. The Owner will pay for all testing and inspecting specifically requested by the Engineer over and above those described in Paragraph 2.1 A. above, including City of Madison permit inspection efforts and inspection of final elevated tank subgrade by Geotechnical firm.
- C. When tests indicate noncompliance with the Contract Documents, all testing and subsequent retesting occasioned by the noncompliance shall be performed by the same testing laboratory and the costs thereof shall be paid by the Contractor.

## PART 3 - EXECUTION

### 3.1 TAKING SPECIMENS

- A. Except as may be specifically otherwise approved by the Engineer, have the testing laboratory secure and handle all samples and specimens for testing.

### 3.2 COOPERATION WITH TESTING LABORATORY

- A. Provide access to the Work at all times and at all locations where the Work is in progress. Provide facilities for such access to enable the laboratory to perform its functions properly.
- B. Furnish casual labor and facilities:
  - 1. To obtain and handle samples at the site or at the source of the product to be tested.
  - 2. To facilitate testing operations.
  - 3. For laboratory's exclusive use for storage and curing of test samples on site.
- C. Notify the testing agency sufficiently in advance of operations to allow for assignment of personnel and scheduling of its operations.
- D. Provide the testing laboratory with copies of approved relevant shop drawings.

END OF SECTION

TESTING LABORATORY SERVICES  
01 45 29-2 (150826.40)

## SECTION 01 50 00

## TEMPORARY FACILITIES AND CONTROLS

## PART 1 - GENERAL

## 1.1 SUMMARY

- A. This Section describes construction facilities and temporary controls required for the Work.
- B. Related work:
  - 1. Documents affecting work of this Section include, but are not necessarily limited to, General Conditions, Supplementary Conditions, and Division 01 - General Requirements of these Specifications.
  - 2. Except that equipment furnished by subcontractors shall comply with requirements of pertinent safety regulations, such equipment normally furnished by the individual trades in execution of their own portions of the Work are not part of this Section.
  - 3. Permanent installation and hookup of the various utility lines are described in other Sections.

## 1.2 REQUIREMENTS

- A. Provide construction facilities and temporary controls needed for the Work including, but not necessarily limited to:
  - 1. Temporary utilities such as heat, water, electricity, and telephone.
  - 2. Field office for the Contractor's personnel, as needed.
  - 3. Sanitary facilities.
  - 4. Enclosures such as fencing, tarpaulins, barricades, and canopies.
  - 5. Temporary fencing of the construction site.
  - 6. Fire extinguishers.
  - 7. Dust and mud control.
  - 8. Traffic control.
  - 9. Security.
  - 10. Temporary work boundary fence on excavations.
  - 11. Construction layout and staking.

## 1.3 DELIVERY, STORAGE, AND HANDLING

- A. Maintain temporary facilities and controls in proper and safe condition throughout progress of the Work.

## PART 2 - PRODUCTS

## 2.1 UTILITIES DURING CONSTRUCTION

- A. Water:
  - 1. The Owner will provide water for the initial filling for flushing and testing of new water main and filling of elevated tank at no cost to the Contractor.

## TEMPORARY FACILITIES AND CONTROLS

01 50 00-1 (150826.40)

2. Provide necessary temporary piping and water supply and, upon completion of the work, remove such temporary facilities.  
The Owner will provide water for use by the Contractor for miscellaneous construction activities. The Contractor will fill his tank truck at the location designated by the Owner. There will be no charge for the water utilized, but Contractor must coordinate the times of loading water with the Owner.

B. Electricity:

1. Provide necessary temporary wiring and, upon completion of the Work, remove such temporary facility.
2. Provide and pay for electricity used in construction.

C. Heating: Provide and maintain heat necessary for proper conduct of operations needed in the Work.

D. Telephone:

1. Provide cellular phone availability for key Contractor staff.

## 2.2 FIELD OFFICES AND SHEDS

A. Contractor's facilities:

1. Provide a field office and sheds adequate in size and accommodation for Contractor's offices, supply, and storage as desired.

## 2.3 SANITARY FACILITIES

A. Provide temporary sanitary facilities meeting Federal, State, and local health department requirements.

1. Maintain in a sanitary condition at all times.

## 2.4 ENCLOSURES

A. Provide and maintain for the duration of construction all scaffolds, tarpaulins, canopies, warning signs, steps, platforms, bridges, and other temporary construction necessary for proper completion of the Work in compliance with pertinent safety and other regulations.

## 2.5 TEMPORARY FENCING

A. Provide and maintain for the duration of construction a temporary fence of design and type needed to prevent entry into any open excavations by Public.

## 2.6 FIRE EXTINGUISHERS

A. Provide and maintain not less than two fire extinguishers, multi-purpose dry chemical type with UL rating of 4A-60 B:C, 10-pound capacity, Amerex Model ABC, or equal, enclosed in suitable protecting cabinets and conveniently located for proper protection.

## TEMPORARY FACILITIES AND CONTROLS

01 50 00-2 (150826.40)

## 2.7 CONSTRUCTION LAYOUT

- A. The Contractor shall furnish construction stakes required for layout and staking of the project.
- B. The Contractor shall provide personnel, equipment, and material to perform layout and staking and to establish supplementary benchmarks.

## PART 3 - EXECUTION

### 3.1 MAINTENANCE AND REMOVAL

- A. Maintain temporary facilities and controls as long as needed for safe and proper completion of the Work.
- B. Remove such temporary facilities and controls as rapidly as progress of the Work will permit, or as directed by the Engineer.

### 3.2 DUST AND MUD CONTROL

- A. Take necessary precautions to control dust and mud associated with the Work, subject to the approval of the Engineer.
  - 1. In dry weather, spray dusty areas daily with water in order to control dust.
  - 2. Apply calcium chloride having a minimum chemical content of 77 percent calcium chloride at an application rate of 3 pounds per square yard of surface covered at locations as directed by the Engineer.
- B. Take necessary steps to prevent the tracking of mud onto adjacent streets and highways.
  - 1. Remove mud resulting from the construction traffic from the adjacent streets and highways.

### 3.3 TRAFFIC CONTROL

- A. Protect and maintain traffic by the proper use of barricades, warning lights, flares, and necessary traffic control and safety devices, conforming to federal, state, and local regulations regarding their use.
- B. Use forms of traffic control on public roadways required by the construction operations in accordance with the latest revision of "Traffic Controls for Construction and Maintenance Operations of the Wisconsin Manual on Uniform Traffic Control Devices", and Section 643, TRAFFIC CONTROL, of the WDOT "Standard Specifications".
- C. Unless the Contractor has obtained written permission from the Engineer to temporarily close any street, alley, or other traveled way, keep such traveled way open to traffic on the existing pavement.

- D. Maintain alternating one-way traffic from opposing directions during working hours. At all other times, provide sufficient width within existing shoulders or curbs to permit one lane of traffic in each direction.
- E. Ensure that all barricades, warning signs, lights, and other devices are operational 24 hours each day, including Sundays and holidays, during the time the contract is in force.
  - 1. In the event of severe weather conditions, provide any additional personnel necessary to properly maintain all traffic control devices.
- F. At the preconstruction meeting, furnish the name of the individual in the Contractor's direct employ who is to be responsible for the installation and maintenance of the traffic control for this project.
  - 1. If the actual installation and maintenance are to be accomplished by a Subcontractor, obtain the Engineer's consent at the time of the preconstruction meeting.
  - 2. The Owner will provide the Contractor with the name of its representative who will be responsible for the administration of the traffic control plan.
- G. Provide access to private driveways at all times except during pipeline installation across a driveway.
  - 1. Keep driveway closure times to an absolute minimum.
  - 2. Warn homeowners 24 hours in advance of a driveway closure, and again just prior to closing to allow homeowners to move their vehicles.
  - 3. Maintain access for emergency vehicles at all times.
- H. Provide access to commercial or industrial driveways at all times except during pipeline installation across a driveway.
  - 1. Keep driveway closure times to an absolute minimum.
  - 2. If two driveway entrances exist, keep one driveway open at all times.
  - 3. Establish schedule for driveway closures with commercial or industrial establishments that will not obstruct passage of employees or customers during heavy use period.
  - 4. Maintain access for emergency vehicles at all times.
- I. The costs for traffic control will be considered incidental to the Contract and no additional compensation will be allowed.

### 3.4 SECURITY

- A. Take whatever measures are necessary to protect the safety of the public, workmen, and materials.
  - 1. Provide inspection of work area daily.
  - 2. Provide the security of the site, both day and night.

### 3.5 CONSTRUCTION LAYOUT AND STAKING

- A. The Contractor shall place construction layout stakes for this project. The Owner will provide adequate reference points and benchmarks. Any additional control points

set by the Owner will be identified in the field to the Contractor and all field notes will be maintained by the Owner.

- B. The Contractor shall establish offset stakes, reference points, and any other horizontal or vertical controls, including supplementary benchmarks necessary to secure a correct layout of the Work.
  - 1. Stakes shall be set at sufficient intervals to assure construction is in conformance with the Drawings.
  - 2. The Contractor will not be required to set additional stakes to locate a utility line which is not included as a Pay Item in the contract or to determine property lines between private properties.
  
- C. The Contractor shall be responsible for having the finished work conform to the lines, grades, elevations, and dimensions shown on the Drawings.
  - 1. Any inspection or checking of the Contractor's layout by the Engineer and the acceptance of all or any part of the layout shall not relieve the Contractor of his/her responsibility to secure the proper dimensions, grades, and elevations of the several parts of the Work.
  - 2. The Contractor shall exercise care in the preservation of stakes and benchmarks and shall have them reset when any are damaged, lost, displaced, removed, or otherwise obliterated.
  
- D. Responsibility of the Contractor:
  - 1. The Contractor shall establish control points necessary to construct the individual project elements.
  - 2. The Contractor shall locate right-of-way and easement points. The Contractor shall set all line stakes for the construction of fences by the Contractor.
  - 3. All work shall be according to normally accepted self-checking surveying practices.
    - a. Field notes shall be kept in standard survey field notebooks and those books shall become the property of the Owner at the completion of the project.
    - b. All notes shall be neat, orderly, and in accepted form.

END OF SECTION

SECTION 01 61 01

GENERAL EQUIPMENT REQUIREMENTS

PART 1 - GENERAL

1.1 SUMMARY

- A. This Section describes the general equipment requirements applicable to all equipment and supplements the detailed equipment specifications.
- B. Related work:
  - 1. Documents affecting work of this Section include, but are not necessarily limited to, General Conditions, Supplementary Conditions, and Division 01 - General Requirements of these Specifications.
- C. References:
  - 1. Reserved.

1.2 SUBMITTALS

- A. Provide Attachment 01 61 01-1, Manufacturer's Certificate of Inspection; Attachment 01 61 01-2, Contractor's Verification of Equipment Inspection; and Attachment 01 61 01-3, Contractor's Equipment Guarantee for equipment as identified in Part 1 of the particular equipment specifications.
- B. Provide field service reports as specified below.
- C. Comply with pertinent provisions of Sections 01 33 01.

1.3 QUALITY ASSURANCE – Reserved.

1.4 DELIVERY, STORAGE, AND HANDLING – Reserved.

1.5 SITE CONDITIONS – Reserved.

1.6 MAINTENANCE – Reserved.

PART 2 - PRODUCTS

2.1 LUBRICANTS

- A. Provide lubricants of the type recommended by the equipment manufacturer for each item of equipment in sufficient quantity for start-up and initial operation of equipment.
- B. Provide lubrication fittings readily accessible from the outside of all equipment without removing covers or guards.

GENERAL EQUIPMENT REQUIREMENTS

01 61 01-1 (150826.40)



## 2.2 SAFETY GUARDS

- A. Cover all drive belts, chains and couplings with suitable guard fabricated of 14 gauge or heavier steel designed for easy installation and removal, unless otherwise specified.

## 2.3 ANCHORS

- A. Provide the size and number of anchor bolts, mechanical anchors and adhesive anchors determined by the equipment manufacturer unless otherwise indicated on the Drawings.
- B. Provide Type 316 stainless steel anchor bolts, threaded rods, nuts, washers, mechanical anchors, adhesive anchors, and other fastener parts for installing equipment, complying with ASTM F593 and F594.
- C. Comply with pertinent provisions of Section 05 50 00.

## PART 3 - EXECUTION

### 3.1 SHOP ASSEMBLY AND MATCHMARKING

- A. Assemble, inspect, and test equipment in the manufacturer's shop as far as is practical.
- B. Provide accurate shopmarking and identification for items to be field erected in accordance with erection details furnished with the equipment.
- C. Provide all fasteners and miscellaneous small parts to be field erected individually packaged for shipment, and identify as to location in accordance with a schedule of fasteners with the equipment.

### 3.2 INSTALLATION, INSPECTION, TESTING AND OPERATOR INSTRUCTIONS

- A. Provide the services of a qualified field service technician from the manufacturer of each piece of equipment to:
  - 1. Inspect the equipment installation including alignment, clearances, field erection where applicable, and initial lubrication where applicable.
  - 2. Ascertain that equipment has been installed in accordance with the manufacturer's recommended procedures and is ready for operation.
- B. For each site visit of the manufacturer's field service technician, submit a field service report from the field service technician within five (5) working days of the visit.
- C. After the installation has been completed in accordance with the manufacturer's recommendations and in the presence of the manufacturer's field service technician,

test the equipment and its appurtenances for proper operating condition and for performance in accordance with these Specifications.

- D. Provide three (3) copies of the Manufacturer's Certificate of Inspection and the Contractor's Verification of Equipment Inspection to the Engineer certifying and verifying that the equipment and all appurtenances supplied with it have been installed in accordance with the manufacturer's recommendations and that the test operation was satisfactory.
  - 1. Use the forms, Attachment 01 61 01-1 and Attachment 01 61 01-2.
- E. Instruct the Owner's personnel in the proper operation and maintenance of the equipment in accordance with the manufacturer's recommendations.

### 3.3 EQUIPMENT GUARANTEE

- A. Guarantee all equipment, motors, electrical controls, and other mechanical devices to operate in accordance with the requirements of these Specifications and replace and repair any guaranteed item found to be defective within two years, or longer period if specifically stated for any particular item, from the date of the Owner's acceptance for use of the equipment without additional expense to the Owner for labor or materials.
  - 1. After obtaining Owner Authorized Representative's signature, provide three (3) copies of a Contractor's Equipment Guarantee WITH ORIGINAL SIGNATURES to the Engineer, using the form, Attachment 01 61 01-3.

END OF SECTION

ATTACHMENT 01 61 01-1

**MANUFACTURER'S CERTIFICATE OF INSPECTION**

Date of Inspection: \_\_\_\_\_

Project Name \_\_\_\_\_

Contractor: \_\_\_\_\_

Equipment Manufacturer: \_\_\_\_\_

Equipment Specification: \_\_\_\_\_

Equipment Type & Name: \_\_\_\_\_

This will certify that I, the manufacturer's representative, have completely checked and inspected the installation of this equipment and it has been properly installed in accordance with our instructions and requirements. I also certify that the equipment has been satisfactorily tested and is now ready for normal operation and use.

I have instructed the Owner's personnel in the proper operation and maintenance of the equipment which we have furnished for this project.

\_\_\_\_\_  
Manufacturer's Representative's Signature

\_\_\_\_\_  
Name and Title

Attendees:

\_\_\_\_\_  
Name and Title

\_\_\_\_\_  
Signature

\_\_\_\_\_  
Name and Title

\_\_\_\_\_  
Signature

\_\_\_\_\_  
Name and Title

\_\_\_\_\_  
Signature

\_\_\_\_\_  
Name and Title

\_\_\_\_\_  
Signature

\_\_\_\_\_  
Name and Title

\_\_\_\_\_  
Signature

\_\_\_\_\_  
Name and Title

\_\_\_\_\_  
Signature

ATTACHMENT 01 61 01-2

**CONTRACTOR'S VERIFICATION OF EQUIPMENT INSPECTION**

Date of inspection: \_\_\_\_\_

Project Name: \_\_\_\_\_

Contractor: \_\_\_\_\_

Equipment Manufacturer: \_\_\_\_\_

Equipment Specification: \_\_\_\_\_

Equipment Type & Name: \_\_\_\_\_

We, the Contractor for the subject project, hereby verify that the equipment manufacturer's serviceman has inspected and tested the installation of this equipment within the last 30 days and has certified that the equipment which we have furnished and installed for this project is now ready for normal operation and use by the Owner.

\_\_\_\_\_  
Contractor's Representative's Signature

\_\_\_\_\_  
Name and Title

ATTACHMENT 01 61 01-3

**CONTRACTOR'S EQUIPMENT GUARANTEE**

Date: \_\_\_\_\_

Project Name: \_\_\_\_\_

Contractor: \_\_\_\_\_

Equipment Manufacturer: \_\_\_\_\_

Equipment Specification: \_\_\_\_\_

Equipment Type & Name: \_\_\_\_\_

We, the Contractor for the subject project, hereby guarantee this equipment for a period of \_\_\_ years from the date of the Owner's acceptance and use of this equipment, and shall replace or repair the equipment or any parts thereof which become defective or do not function properly during normal operation and maintenance without any additional expense to the Owner for labor or materials.

\_\_\_\_\_  
Contractor's Representative's Signature

\_\_\_\_\_  
Name and Title

ACCEPTED this \_\_\_\_\_ day of \_\_\_\_\_, 20\_\_\_\_, for Owner's use and initiation of Contractor's Equipment Guarantee. The Owner hereby accepts responsibility for operation and maintenance of said equipment as of this date.

\_\_\_\_\_  
Owner's Representative's Signature

\_\_\_\_\_  
Name and Title

## SECTION 01 62 01

## PRODUCT OPTIONS AND SUBSTITUTIONS

## PART 1 - GENERAL

## 1.1 SUMMARY

- A. This Section describes product options available to bidders and the Contractor, plus procedures for securing approval of proposed substitutions.
- B. Related work:
  - 1. Documents affecting work of this Section include, but are not necessarily limited to, General Conditions, Supplementary Conditions, and Division 01 - General Requirements of these Specifications.
  - 2. Make submittals after the Effective Date of the Agreement in accordance with pertinent provisions of Section 01 33 01.

## 1.2 PRODUCT OPTIONS

- A. The Contract is based on standards of quality established in the Contract Documents.
  - 1. In agreeing to the terms and conditions of the Contract, the Contractor has accepted a responsibility to verify that the specified products will be available and to place orders for all required materials in such a timely manner as is needed to meet his agreed construction schedule.
  - 2. Neither the Owner nor the Engineer has agreed to the substitution of materials or methods called for in the Contract Documents, except as they may specifically otherwise state in writing.
- B. Materials and/or equipment specified by name:
  - 1. Where materials and/or equipment are specified by naming one single manufacturer and/or model number, followed by words that indicate no substitution is permitted, only the material and/or equipment named is approved for incorporation into the Work.
  - 2. Should the Contractor demonstrate to the approval of the Engineer that a specified material or method was ordered in a timely manner and will not be available in time for incorporation into this Work, the Contractor shall submit to the Engineer such data on proposed substitute materials and/or equipment as are needed to help the Engineer determine suitability of the proposed substitution.
- C. Where materials and/or equipment are specified by name and/or model number, followed by the words "or equal":
  - 1. The material and/or equipment specified by name establishes the required standard of quality.

## PRODUCT OPTIONS AND SUBSTITUTIONS

01 62 01-1 (150826.40)

2. Materials and/or equipment proposed by the Contractor to be used in lieu of materials and/or equipment so specified by name shall in all ways equal or exceed the qualities of the named materials and/or equipment.
  3. The Contractor may propose "substitute" or "or equal" items for non-major equipment in accordance with Paragraph 6.05 of the General Conditions.
    - a. If in the Engineer's sole discretion an item of material or equipment proposed by the Contractor does not qualify as an "or equal" item, the Engineer will notify the Contractor in writing that the item will be considered as a "substitute" item. If the Contractor wishes for the Engineer to continue the evaluation, the Contractor shall submit additional information in accordance with Paragraph 6.05.A.2 of the General Conditions.
  4. The Engineer will record all time used by the Engineer to evaluate proposed substitute items. Owner will reimburse the Engineer at the Engineer's standard hourly rate for all time spent evaluating proposed substitute items and deduct such costs from payments due the Contractor. Costs associated with review of proposed "or equal" items will not be charged to the Contractor.
- D. Products specified by reference to standard specifications such as ASTM and similar standards do not require submittal except for interface within the Work.

### 1.3 DELAYS

- A. Delays in construction arising by virtue of the non-availability of a specified material and/or method will not be considered by the Engineer as justifying an extension of the agreed Contract Time.

END OF SECTION

## SECTION 01 66 11

## STORAGE AND PROTECTION OF MATERIAL AND EQUIPMENT

## PART 1 - GENERAL

## 1.1 SUMMARY

- A. Protect products scheduled for use in the Work by means including, but not necessarily limited to, those described in this Section.
- B. Related work:
  - 1. Documents affecting work of this Section include, but are not necessarily limited to, General Conditions, Supplementary Conditions, and Division 01 - General Requirements of these Specifications.
  - 2. Additional procedures also may be prescribed in other Sections of these Specifications.
- C. References:
  - 1. Reserved.

## 1.2 SUBMITTALS – Reserved.

## 1.3 QUALITY ASSURANCE – Reserved.

## 1.4 DELIVERY, STORAGE, AND HANDLING

- A. Comply with Section 01 14 11 for Contractor's storage area.
- B. Comply with the requirements of this Section for off-site storage.
  - 1. The Engineer reserves the right to visit and observe the off-site storage areas.
- C. Store equipment and materials in accordance with the manufacturer's instructions.
- D. Provide temporary weathertight enclosures to protect products from damage by the elements.
- E. Protect finished surfaces through which equipment and materials are handled.
- F. Provide protection for finished floor surfaces in traffic areas prior to allowing equipment or materials to be moved over such surfaces.
- G. Maintain finished surfaces clean, unmarred, and suitably protected until accepted by the Owner.
- H. Do not store plant maintenance equipment, furniture, and laboratory equipment on site until they are needed by the Owner or for progress of work.

## STORAGE AND PROTECTION OF MATERIAL &amp; EQUIPMENT

01 66 11-1 (150826.40)



1.5 SITE CONDITIONS – Reserved.

1.6 MAINTENANCE – Reserved.

1.7 MANUFACTURERS' RECOMMENDATIONS

- A. Except as otherwise approved by the Engineer, determine and comply with manufacturers' recommendations on product handling, storage, and protection.

1.8 PACKAGING

- A. Deliver products to the job site in their manufacturer's original container, with labels intact and legible.
  - 1. Maintain packaged materials with seals unbroken and labels intact until time of use.
  - 2. Promptly remove damaged material and unsuitable items from the job site, and promptly replace with material meeting the specified requirements, at no additional cost to the Owner.
- B. The Engineer may reject as non-complying such material and products that do not bear identification satisfactory to the Engineer as to manufacturer, grade, quality, and other pertinent information.

1.9 REPAIRS AND REPLACEMENTS

- A. In event of damage, promptly make replacements and repairs to the approval of the Engineer and at no additional cost to the Owner.
- B. Additional time required to secure replacements and to make repairs will not be considered by the Engineer to justify an extension in the Contract Time of Completion.

END OF SECTION

SECTION 01 73 29  
CUTTING AND PATCHING

PART 1 - GENERAL

1.1 SUMMARY

- A. This Section establishes general requirements pertaining to cutting (including excavating), fitting, and patching of the Work required to:
  - 1. Make the several parts fit properly.
  - 2. Uncover work to provide for installing, inspecting, or both, of ill-timed work.
  - 3. Remove and replace work not conforming to requirements of the Contract Documents.
  - 4. Remove and replace defective work.
  
- B. Related work:
  - 1. Documents affecting work of this Section include, but are not necessarily limited to, General Conditions, Supplementary Conditions, and Division 01 - General Requirements of these Specifications.
  - 2. In addition to other requirements specified, upon the Engineer's request uncover work to provide for inspection by the Engineer of covered work, and remove samples of installed materials for testing.
  - 3. Do not cut or alter work performed under separate contracts without the Engineer's written permission.

1.2 SUBMITTALS

- A. Request for Engineer's consent:
  - 1. Prior to cutting which affects structural safety, submit written request to the Engineer for permission to proceed with cutting.
  - 2. Should conditions of the Work, or schedule, indicate a required change of materials or methods for cutting and patching, so notify the Engineer and secure his written permission and the required Change Order prior to proceeding.
  
- B. Notices to the Engineer:
  - 1. Prior to cutting and patching performed pursuant to the Engineer's instructions, submit cost estimate to the Engineer. Secure the Engineer's approval of cost estimates and type of reimbursement before proceeding with cutting and patching.
  - 2. Submit written notice to the Engineer designating the time the Work will be uncovered, to provide for the Engineer's observation.

PART 2 - PRODUCTS

2.1 MATERIALS

- A. For replacement of items removed, use materials complying with pertinent Sections of these Specifications.

## 2.2 PAYMENT FOR COSTS

- A. The Owner will reimburse the Contractor for cutting and patching performed pursuant to a written Change Order, after claim for such reimbursement is submitted by the Contractor. Perform other cutting and patching needed to comply with the Contract Documents at no additional cost to the Owner.

## PART 3 - EXECUTION

### 3.1 SURFACE CONDITIONS

- A. Inspection:
  - 1. Inspect existing conditions, including elements subject to movement or damage during cutting, excavating, patching, and backfilling.
  - 2. After uncovering the work, inspect conditions affecting installation of new work.
- B. Discrepancies:
  - 1. If uncovered conditions are not as anticipated, immediately notify the Engineer and secure needed directions.
  - 2. Do not proceed until unsatisfactory conditions are corrected.

### 3.2 PREPARATION PRIOR TO CUTTING

- A. Provide required protection including, but not necessarily limited to, shoring, bracing, and support to maintain structural integrity of the Work.

### 3.3 PERFORMANCE

- A. Perform required excavating and backfilling as required under pertinent other Sections of these Specifications.
- B. Perform cutting and demolition by methods which will prevent damage to other portions of the Work and provide proper surfaces to receive installation of repair and new work.
- C. Perform fitting and adjusting of products to provide finished installation complying with the manufacturer's recommendations for specified equipment, products, tolerances, and finishes.
- D. Perform slight alterations needed to make adjustable parts fit to fixed parts to provide a complete installation.
- E. Refinish surfaces as necessary to match adjacent finishes.

END OF SECTION

## SECTION 01 74 23

### FINAL CLEANING

#### PART 1 - GENERAL

##### 1.1 SUMMARY

- A. Throughout the construction period, maintain the buildings and site in a standard of cleanliness as described in this Section.
- B. Related work:
  - 1. Documents affecting work of this Section include, but are not necessarily limited to, General Conditions, Supplementary Conditions, and Division 01 – General Requirements of these Specifications.
  - 2. In addition to standards described in this Section, comply with requirements for cleaning as described in other pertinent Sections of these Specifications.

##### 1.2 QUALITY ASSURANCE

- A. Conduct daily inspection, and more often if necessary, to verify that requirements for cleanliness are being met.
- B. In addition to the standards described in this Section, comply with pertinent requirements of governmental agencies having jurisdiction.

#### PART 2 - PRODUCTS

##### 2.1 CLEANING MATERIALS AND EQUIPMENT

- A. Provide required personnel, equipment, and materials needed to maintain the specified standard of cleanliness.

##### 2.2 COMPATIBILITY

- A. Use only the cleaning materials and equipment which are compatible with the surface being cleaned, as recommended by the manufacturer of the material.

#### PART 3 - EXECUTION

##### 3.1 PROGRESS CLEANING

- A. General:
  - 1. Retain stored items in an orderly arrangement allowing maximum access, not impeding traffic or drainage, and providing required protection of materials.

2. Do not allow accumulation of scrap, debris, waste material, and other items not required for construction of this Work.
  3. At least twice each month, and more often if necessary, completely remove all scrap, debris, and waste material from the job site.
  4. Provide adequate storage for all items awaiting removal from the job site, observing requirements for fire protection and protection of the environment.
- B. Site:
1. Daily, and more often if necessary, inspect the site and pick up all scrap, debris, and waste material. Remove such items to the place designated for their storage.
  2. Weekly, and more often if necessary, inspect all arrangements of materials stored on the site. Restack, tidy, or otherwise service arrangements to meet the requirements of Paragraph 3.1 A. 1. above.
  3. Maintain the site in a neat and orderly condition at all times.
- C. Structures:
1. Weekly, and more often if necessary, inspect the structures and pick up all scrap, debris, and waste material. Remove such items to the place designated for their storage.
  2. Weekly, and more often if necessary, sweep interior spaces clean.
    - a. "Clean," for the purpose of this subparagraph, shall be interpreted as meaning free from dust and other material capable of being removed by use of reasonable effort and a hand-held broom.
  3. As required preparatory to installation of succeeding materials, clean the structures or pertinent portions thereof to the degree of cleanliness recommended by the manufacturer of the succeeding material, using equipment and materials required to achieve the necessary cleanliness.
  4. Following the installation of finish floor materials, clean the finish floor daily (and more often if necessary) at all times while work is being performed in the space in which finish materials are installed.
    - a. "Clean," for the purpose of this subparagraph, shall be interpreted as meaning free from foreign material which, in the opinion of the Engineer, may be injurious to the finish floor material.

### 3.2 FINAL CLEANING

- A. "Clean," for the purpose of this Article, and except as may be specifically provided otherwise, shall be interpreted as meaning the level of cleanliness generally provided by skilled cleaners using commercial quality building maintenance equipment and materials.
- B. Prior to completion of the Work, remove from the job site all tools, surplus materials, equipment, scrap, debris, and waste. Conduct final progress cleaning as described in Paragraph 3.1 above.

- C. Site:
  - 1. Unless otherwise specifically directed by the Engineer, broom clean paved areas on the site and public paved areas adjacent to the site.
  - 2. Completely remove resultant debris.
  
- D. Structures:
  - 1. Exterior:
    - a. Visually inspect exterior surfaces and remove all traces of soil, waste materials, smudges, and other foreign matter.
    - b. Remove all traces of splashed materials from adjacent surfaces.
    - c. If necessary to achieve a uniform degree of cleanliness, hose down the exterior of the structure.
    - d. In the event of stubborn stains not removable with water, the Engineer may require light sandblasting or other cleaning at no additional cost to the Owner.
  - 2. Interior:
    - a. Visually inspect interior surfaces and remove all traces of soil, waste materials, smudges, and other foreign matter.
    - b. Remove all traces of splashed material from adjacent surfaces.
    - c. Remove paint droppings, spots, stains, and dirt from finished surfaces.
  - 3. Glass: Clean inside and outside.
  - 4. Polished surfaces: To surfaces requiring routine application of buffed polish, apply the polish recommended by the manufacturer of the material being polished.
  
- E. Schedule final cleaning as approved by the Engineer to enable the Owner to accept a completely clean Work.

### 3.3 CLEANING DURING OWNER'S OCCUPANCY

- A. Should the Owner occupy the Work or any portion thereof prior to its completion by the Contractor and acceptance by the Owner, responsibilities for interim and final cleaning shall be as determined by the Engineer in accordance with the General Conditions of the Contract.

END OF SECTION

SECTION 01 77 01  
CONTRACT CLOSEOUT

PART 1 - GENERAL

1.1 SUMMARY

- A. This Section describes an orderly and efficient transfer of the completed Work to the Owner.
- B. Related work:
  - 1. Documents affecting work of this Section include, but are not necessarily limited to, General Conditions, Supplementary Conditions, and Division 01 – General Requirements of these Specifications.
  - 2. Activities relative to Substantial Completion and Contract closeout are described in the General Conditions.

1.2 QUALITY ASSURANCE

- A. Prior to requesting that the Engineer issue a certificate of Substantial Completion in accordance with Paragraph 14.04 or 14.05 of the General Conditions, use adequate means to assure that the Work is completed in accordance with the specified requirements and is ready for a joint inspection by Owner, Contractor, and Engineer.

1.3 PROCEDURES

- A. Substantial Completion:
  - 1. Prepare the list required by Paragraph 14.04.A of the General Conditions and submit it along with a written request that Engineer issue a certificate of Substantial Completion.
  - 2. Within a reasonable time after receipt of the list, Owner, Contractor, and Engineer will jointly inspect the Work to determine status of completion.
  - 3. Should the Engineer determine that the Work is not substantially complete:
    - a. The Engineer will so notify the Contractor, in writing, giving the reasons therefore.
    - b. Remedy the deficiencies and notify the Engineer when ready for reinspection.
    - c. Owner, Contractor, and Engineer will reinspect the Work.
  - 4. When the Engineer concurs that the Work is substantially complete:
    - a. The Engineer will prepare a tentative "Certificate of Substantial Completion," accompanied by the Contractor's list of items to be completed or corrected, as verified by the Engineer.
    - b. The Engineer will submit the tentative Certificate to the Contractor for acceptance.

- c. After Contractor signs and returns the tentative Certificate to Engineer, Engineer will submit the tentative Certificate to Owner accompanied by a tentative list of items to be completed or corrected before final payment.
- d. Owner will have seven days after receipt of the tentative Certificate during which to make objection to Engineer as to any provisions of the Certificate on attached list.
  - (1) If Owner objects, Engineer will consider Owner's objections. If, after considering Owner's objections, Engineer concludes that the Work is not substantially complete, Engineer will, within fourteen days after submission of the tentative Certificate to Owner, notify Contractor in writing, stating reasons therefor. If, after considering Owner's objections, Engineer considers the Work substantially complete, Engineer will within said fourteen days execute and deliver to Owner and Contractor, a definitive Certificate of Substantial Completion (with a revised tentative list of items to be completed or corrected) reflecting such changes from the tentative Certificate as Engineer believes justified after consideration of any objections of Owner.
  - (2) If Owner has no objections, Engineer will within fourteen days after submission of the tentative Certificate to Owner and Contractor issue a definitive Certificate of Substantial Completion.
- e. At the time of delivery of the tentative Certificate of Substantial Completion, Engineer will deliver to Owner and Contractor a written recommendation as to division of responsibilities pending final payment between Owner and Contractor with respect to security, operation, safety, maintenance, heat, utilities, insurance, warranties, and guarantees. Unless Owner or Contractor advise the Engineer in writing of any objections within seven days after delivery of the tentative Certificate of Substantial Completion, the Engineer's aforesaid recommendation will be binding on Owner and Contractor until final payment.

B. Final Completion:

- 1. Prepare and submit the notice required by the first sentence of Paragraph 14.06.A of the General Conditions.
- 2. Verify that the Work is complete including, but not necessarily limited to, the items mentioned in Paragraph 14.07.A of the General Conditions.
- 3. Certify that:
  - a. Contract Documents have been reviewed.
  - b. Work has been inspected for compliance with the Contract Documents.
  - c. Work has been completed in accordance with the Contract Documents.



- d. Equipment and systems have been tested as required, and are operational.
  - e. Work is completed and ready for final inspection.
  - 4. Owner, Contractor, and Engineer will make a joint inspection to verify status of completion.
  - 5. Should the Engineer determine that the Work is incomplete or defective:
    - a. The Engineer will so notify the Contractor, in writing, listing the incomplete or defective work.
    - b. The Contractor will remedy the deficiencies promptly, and notify the Engineer when ready for reinspection.
  - 6. When the Engineer determines that the Work is acceptable under the Contract Documents, he will request the Contractor to make closeout submittals.
- C. Closeout submittals include, but are not necessarily limited to:
- 1. Project Record Documents described in Section 01 78 39.
  - 2. Manufacturer's Certificate of Inspection, Contractor's Verification of Equipment Inspection, and Contractor's Equipment Guarantee for each item of equipment as required in Section 01 61 01.
  - 3. Warranties and bonds.
  - 4. Keys and keying schedule.
  - 5. Spare parts and materials extra stock.
  - 6. Evidence of compliance with requirements of governmental agencies having jurisdiction including, but not necessarily limited to:
    - a. Certificates of Inspection.
    - b. Certificates of Occupancy.
  - 7. Certificates of Insurance for products and completed operations;
  - 8. Evidence of payment and release of liens; and
  - 9. Affidavit of Compliance with Prevailing Wage Rate Determination and Affirmative Action requirements.
  - 10. List of subcontractors, service organizations, and principal vendors, including names, addresses, and telephone numbers where they can be reached for emergency service at all times including nights, weekends, and holidays.
- D. Final adjustment of accounts:
- 1. Submit a final statement of accounting to the Engineer, showing all adjustments to the Contract Price.
  - 2. If so required, the Engineer will prepare a final Change Order showing adjustments to the Contract Price which have not been made by previous Change Orders.

END OF SECTION

CONTRACT CLOSEOUT  
01 77 01-3 (150826.40)

SECTION 01 78 26  
OPERATION AND MAINTENANCE MANUAL

PART 1 - GENERAL

1.1 SUMMARY

- A. To aid the continued instruction of operating and maintenance personnel, and to provide a positive source of information regarding products incorporated into the Work, furnish and deliver the manuals described in pertinent Sections of these Specifications.
- B. Related work:
  - 1. Documents affecting work of this Section include, but are not necessarily limited to, General Conditions, Supplementary Conditions, and Division 01 – General Requirements of these Specifications.

1.2 SUBMITTALS

- A. Comply with pertinent provisions of Section 01 33 01.
- B. Submit three copies of the required manuals for each item of equipment to the Engineer no later than 30 days following the Engineer's approval of shop drawings for said item of equipment, plus one electronic copy in searchable .pdf format.

1.3 QUALITY ASSURANCE

- A. Use only personnel who are thoroughly trained and experienced in operation and maintenance of the described items, completely familiar with the requirements of this Section, and skilled in technical writing to the extent needed for communicating the essential data.

PART 2 - PRODUCTS

2.1 OPERATION AND MAINTENANCE MANUALS

- A. Where operation and maintenance manuals are required to be submitted under other Sections of these Specifications, prepare in accordance with the provisions of this Section.
- B. Format:
  - 1. Size: 8-1/2" x 11".
  - 2. Paper: White bond, at least 20 lb weight.
  - 3. Text: Neatly printed.
  - 4. Drawings: 11" in height preferable; bind in with text; foldout acceptable; larger drawings acceptable but fold to fit within the manual and provide a drawing pocket inside rear cover or bind in with text.
  - 5. Flysheets: Separate each portion of the manual with neatly prepared flysheets briefly describing contents of the ensuing portion; flysheets may be in color.

- 6. Binding: Use heavy-duty plastic or fiberboard covers with binding mechanism concealed inside the manual; 3-ring binders will be acceptable.
- 7. Measurements: Provide all measurements in U.S. standard units such as feet-and-inches, lbs., and cfm; where items may be expected to be measured within ten years in accordance with metric formulas, provide additional measurements in the "International System of Units" (SI).

C. Provide front and back covers for each manual, using durable material, and clearly identified on or through the cover with at least the following information:

OPERATING AND MAINTENANCE MANUALS

( )
( Name and address of Work )
( )
( Name of Contractor )
( )
( General subject of this Manual )
( )
( Engineer, and approval date )

- D. Contents: Include at least the following:
- 1. Neatly typewritten index near the front of the manual, giving immediate information as to location within the manual of all emergency information regarding the installation.
  - 2. Complete instructions regarding operation and maintenance of all equipment involved including lubrication, disassembly, and reassembly.
  - 3. Complete nomenclature of all parts of the equipment.
  - 4. Complete nomenclature and part number of all replaceable parts, name and address of nearest vendor, and all other data pertinent to procurement procedures.
  - 5. Manufacturers' bulletins, cuts, and descriptive data, where pertinent, clearly indicating the precise items included in this installation and deleting, or otherwise clearly indicating, all manufacturers' data with which this installation is not concerned.
  - 6. Such other data as required in pertinent other Sections of these Specifications.

PART 3 - EXECUTION

3.1 TIMING AND PAYMENT

- A. Make submittals far enough in advance of scheduled dates for equipment installation to provide at least ten (10) working days for review by the Engineer following the Engineer's receipt of the submittal.
- B. Payment for the fabrication, delivery, or installation of any equipment will be withheld until the Engineer has received the required operation and maintenance manual(s).

END OF SECTION

OPERATION AND MAINTENANCE MANUAL

01 78 26-2 (150826.40)

## SECTION 01 78 39

## PROJECT RECORD DOCUMENTS

## PART 1 - GENERAL

## 1.1 SUMMARY

- A. Throughout progress of the Work, maintain an accurate record of changes in the Contract Documents, as described in Paragraph 3.1 below and, upon completion of the Work, submit the recorded changes as described in Paragraph 3.2 below.
- B. Related work:
  - 1. Documents affecting work of this Section include, but are not necessarily limited to, General Conditions, Supplementary Conditions, and Division 01 – General Requirements of these Specifications.
  - 2. Other requirements affecting Project Record Documents may appear in pertinent other Sections of these Specifications.

## 1.2 SUBMITTALS

- A. Comply with pertinent provisions of Section 01 33 01.
- B. The Engineer's approval of the current status of Project Record Documents may be a prerequisite to the Engineer's approval of requests for progress payment and request for final payment under the Contract.
- C. Prior to submitting each request for progress payment, secure the Engineer's approval of the current status of the Project Record Documents.
- D. Prior to submitting request for final payment, submit the final Project Record Documents to the Engineer and secure his approval.

## 1.3 QUALITY ASSURANCE

- A. Delegate the responsibility for maintenance of Record Documents to one person on the Contractor's staff as approved by the Engineer.
- B. Accuracy of records:
  - 1. Thoroughly coordinate changes within the Record Documents, making adequate and proper entries on each page of Specifications and each sheet of Drawings and other Documents where such entry is required to show the change properly.
  - 2. Accuracy of records shall be such that future search for items shown in the Contract Documents may rely reasonably on information obtained from the approved Project Record Documents.

## PROJECT RECORD DOCUMENTS

01 78 39-1 (150826.40)

- C. Make entries within 24 hours after receipt of information that the change has occurred.
- D. Do not conceal any work until the required information is recorded.

#### 1.4 DELIVERY, STORAGE, AND HANDLING

- A. Maintain the job set of Record Documents completely protected from deterioration and from loss and damage until completion of the Work and transfer of all recorded data to the final Project Record Documents.
- B. In the event of loss of recorded data, use means necessary to again secure the data to the Engineer's approval.
  - 1. Such means shall include, if necessary in the opinion of the Engineer, removal and replacement of concealing materials.
  - 2. In such case, provide replacements to the standards originally required by the Contract Documents.

### PART 2 - PRODUCTS

#### 2.1 RECORD DOCUMENTS

- A. Job set: Promptly following receipt of the Owner's Notice to Proceed, secure from the Engineer at no charge to the Contractor one complete set of all Documents comprising the Contract.

### PART 3 - EXECUTION

#### 3.1 MAINTENANCE OF JOB SET

- A. Immediately upon receipt of the job set described in Paragraph 2.1 A. above, identify each of the Documents with the title, "RECORD DOCUMENTS - JOB SET".
- B. Preservation:
  - 1. Considering the Contract completion time, the probable number of occasions upon which the job set must be taken out for new entries and for examination, and the conditions under which these activities will be performed, devise a suitable method for protecting the job set.
  - 2. Do not use the job set for any purpose except entry of new data and for review by the Engineer.
  - 3. Maintain the job set at the site of Work where designated by the Engineer.

- C. Making entries on Drawings:
  - 1. Using an erasable colored pencil (not ink or indelible pencil), clearly describe the change by graphic line and note as required.
  - 2. Date all entries.
  - 3. Call attention to the entry by a "cloud" drawn around the area or areas affected.
  - 4. In the event of overlapping changes, use different colors for the overlapping changes.
- D. Make entries in the pertinent other Documents as approved by the Engineer.
- E. Conversion of schematic layouts:
  - 1. In some cases on the Drawings, arrangements of conduits, circuits, piping, ducts, and similar items, is shown schematically and is not intended to portray precise physical layout.
    - a. Final physical arrangement is determined by the Contractor, subject to the Engineer's approval.
    - b. However, design of future modifications of the facility may require accurate information as to the final physical layout of items which are shown only schematically on the Drawings.
  - 2. Show on the job set of Record Drawings, by dimension accurate to within one inch, the centerline of each run of items such as are described in Paragraph 3.1 E. 1. above.

### 3.2 REVIEW AND SUBMITTAL

- A. Submit the completed set of Project Record Documents to the Engineer as described in Paragraph 1.2 D. above.
- B. Participate in review meetings as required.
- C. Make required changes and promptly deliver the final Project Record Documents to the Engineer.

### 3.3 CHANGES SUBSEQUENT TO ACCEPTANCE

- A. The Contractor has no responsibility for recording changes in the Work subsequent to Final Completion, except for changes resulting from work performed under Warranty.

END OF SECTION

## SECTION 01 91 58

## FACILITY STARTUP

## PART 1 - GENERAL

## 1.1 SUMMARY

- A. This Section describes the Contractor's general equipment requirements for facility start-up.
- B. Related work:
  - 1. Documents affecting work of this Section include, but are not necessarily limited to, General Conditions, Supplementary Conditions, and Division 01 and Division 02 of these Specifications.

## 1.2 SUBMITTALS

- A. Submit a detailed plan and schedule for start-up of the facility at least thirty (30) days prior to the scheduled start-up of the facility.

## PART 2 - PRODUCTS

No products are required in this Section.

## PART 3 - EXECUTION

## 3.1 CONTRACTOR'S REQUIREMENTS

- A. In addition to the services required to comply with Section 01 61 01, Articles 3.2 and 3.3, provide the services of a qualified and experienced factory employed field service engineer from each equipment manufacturer:
  - 1. Ascertain that equipment has been installed in accordance with the manufacturer's recommended procedures.
  - 2. Ascertain that equipment is operational and ready for start-up.
  - 3. Make necessary repairs, corrections, and/or modifications prior to the scheduled start-up.
- B. Coordinate efforts of various equipment field service engineers with construction activities including painting and facility disinfection.
  - 1. Complete painting of equipment containing process water prior to disinfection.
  - 2. Successfully complete facility disinfection prior to start-up in accordance with appropriate provisions of AWWA C-652 and AWWA C-653, including Elevated Tank 126.

- C. Perform the above services at least two weeks prior to the scheduled start-up.
- D. Perform the facility start-up procedures in the presence of the Owner and Engineer.
- E. Operate the facility without problems for a period of fourteen (14) consecutive days prior to Owner's acceptance of the facility.

END OF SECTION



## SECTION 03 30 00

## CAST-IN-PLACE CONCRETE

## PART 1 - GENERAL

## 1.1 SUMMARY

- A. Provide cast-in-place concrete, including formwork and reinforcement, as shown on the Drawings, as specified herein, and as needed for a complete and proper installation.
- B. Related work:
  - 1. Documents affecting work of this Section include, but are not necessarily limited to, General Conditions, Supplementary Conditions, and Division 01 - General Requirements of these Specifications.
- C. See specification Section 33 16 19.33, Concrete/Steel Composite Water Storage Tank for specific information regarding concrete requirements for the water storage tank, including concrete support structure architectural concrete, which may exceed the requirements of this section.

## 1.2 SUBMITTALS

- A. Shop Drawing Submittals:
  - 1. Prior to placing concrete on the project, submit the following to the Engineer for approval:
    - a. Testing laboratory reports for each proposed concrete mix, design proportions and sieve analysis, and soundness tests for fine and coarse aggregates.
    - b. Test results for strength, slump, and entrained air content in accordance with the latest requirements of ASTM C39 and ASTM C192 on trial mix or field-testing records completed within previous 24 months. Perform strength tests on two test cylinders after 7 days curing and on two cylinders after 28 days curing.
    - c. Evidence of compliance with ASTM specifications for materials proposed to be used in the concrete mix.
    - d. Detailed reinforcing bar fabrication drawings prepared in accordance with ACI 315 including location of bar splices proposed by the Contractor in addition to those shown on the Drawings.
    - e. Casting plan indicating the location of construction joints which are proposed by the Contractor in addition to those shown on the Drawings.
  - 2. Submit, within 10 days of testing, duplicate copies of each laboratory report for concrete tests on samples taken at the jobsite, including the following information in each test report:
    - a. Project name.
    - b. Description of concrete work.

## CAST-IN-PLACE CONCRETE

03 30 00-1 (150826.40)

- c. Quantity of concrete placed.
  - d. Dates of samples and testing.
  - e. Slump.
  - f. Total air content.
  - g. Compressive strength.
  - h. Air temperature at time of sampling.
3. Submit manufacturer's data to prove compliance with the specifications for the following products:
- a. Non-shrink grout.
  - b. Anchoring adhesive.
- B. Comply with pertinent provisions of Section 01 33 01.

### 1.3 QUALITY ASSURANCE

- A. Use adequate numbers of skilled workmen who are thoroughly trained and experienced in the necessary crafts and who are completely familiar with the specified requirements and the methods needed for proper performance of the work of this Section.
- B. Comply with "Specifications for Structural Concrete for Buildings," ACI 301, except as may be modified herein.
- C. Provide access for, and cooperate with, the inspector and testing laboratory described in Section 01 45 29 of these Specifications.

### 1.4 DELIVERY, STORAGE, AND HANDLING

- A. Comply with pertinent provisions of Section 01 66 11.
- B. Provide proper storage for reinforcing steel at the project site, including protective covering and blocking to keep steel off the ground.

## PART 2 - PRODUCTS

### 2.1 FORMS

- A. Use smooth, clean plywood or metal lined panels in good condition for forming exposed concrete surfaces including interior and exterior walls, beams, columns, and slabs. Coat the forms with a non-staining, non-reactive mineral oil.
- B. Use form liners for exposed ceilings.
- C. Provide 3/4-inch chamfers on exposed corners.
- D. When reusing lumber for formwork, remove nails, thoroughly clean, and fill and finish holes to produce smooth concrete surfaces free of defects.

- E. Provide temporary openings at the base of column and wall forms and elsewhere as required to facilitate cleaning and final inspection prior to concrete placement.
- F. Form Ties: Factory-fabricated steel snap-off or coil tie assemblies designed to resist the lateral pressure of fresh concrete on forms and to prevent spalling of concrete on removal.
  - 1. Furnish tie assemblies that will leave no metal or other material except concrete within 1½ inches of the formed surface when forms, inserts and tie ends are removed.
  - 2. Furnish tie assemblies that provide cone-shaped depressions in the forms at the surface, at least 1-inch in diameter and 1½ inches deep, to allow filling and patching.
  - 3. Do not use common wire for form ties.

## 2.2 REINFORCEMENT

- A. Comply with the following:
  - 1. Bars: Deformed billet steel conforming to ASTM A615, grade 60, unless otherwise shown on the Drawings.
  - 2. Welded wire reinforcement: Sheets of longitudinal and transverse cold drawn smooth steel wires electrically welded together at intersections, conforming to ASTM A185.
  - 3. Tie wire: 16 gauge annealed steel wire.
- B. Fabricate reinforcement in accordance with the latest provisions of ACI 318 "Building Code Requirements for Structural Concrete".
- C. Shop fabricate bars by cold bending to the dimensions and shapes shown on the detail shop drawings unless otherwise shown on the Drawings or approved by the Engineer.
- D. Use bars that are free from paint, oil, dirt, scale, or excessive rust which will destroy or reduce the bond when embedded in concrete.

## 2.3 CONCRETE

- A. Comply with the following:
  - 1. Portland cement: ASTM C150, Type I or II.
  - 2. Aggregate, general:
    - a. ASTM C33, uniformly graded and clean;
    - b. 35 to 50 percent ratio of fine aggregate to total aggregate by weight of surface dry materials.
  - 3. Aggregate, coarse: Pass a 1.500-inch sieve.
  - 4. Aggregate, fine: Pass a 0.375-inch sieve.
  - 5. Water: Fresh, clean, and free of oils, acids, alkalies, organic matter and deleterious substances.
- B. Provide concrete with the following properties:
  - 1. Minimum 28-day compressive strength: 4,000 psi.

2. Maximum water-cement ratio: 0.45 by weight.
  3. Minimum cement content: 520 pounds per cubic yard.
  4. Minimum slump: 1-inch.
  5. Maximum slump:
    - a. 3 inches for footings.
    - b. 4 inches for slabs, walls, beams, girders, and columns.
- C. Use air-entrained concrete except where a smooth steel trowel finish is required. Provide a total air content of 4 to 6 percent by volume.

#### 2.4 NON-SHRINK GROUT

- A. Furnish pre-mixed, non-metallic, non-staining, non-corrosive, non-gas liberating, cement-based grout specifically recommended by the manufacturer for interior and exterior applications and complying with U.S. Corps of Engineers' Specification CRD C-621 and ASTM C1107.
- B. Acceptable products:
1. Multipurpose Grout, Dayton Superior Corporation.
  2. Or equal.

#### 2.5 CONCRETE ADMIXTURES

- A. Air-entraining admixtures: Conform to the latest requirements of ASTM C260.
- B. Water reducing admixtures:
1. Conform to the latest requirements of ASTM C494.
  2. Type A (normal setting type) for all concrete.
  3. Type D (retarding setting type) or Type E (accelerating setting type) when approved by the Engineer.
- C. Fly ash admixtures (when approved by the Engineer):
1. Maximum sulfur trioxide content: 5 percent.
  2. Maximum loss of ignition: 5 percent.
- D. Do not add calcium chloride, salts, or chemical antifreeze compounds to concrete.

#### 2.6 ANCHORING ADHESIVE

- A. Provide a cartridge type, two-component, high solids acrylic-based adhesive system dispensed and mixed through a static mixing nozzle supplied by the manufacturer.
- B. Furnish material suitable for anchorage of reinforcing bars and threaded rods in cracked and uncracked concrete to resist long-term sustained loading, tested and qualified in accordance with the International Code Council Acceptance Criteria for Post-installed Adhesive Anchors in Concrete Elements (AC308).
- C. Acceptable products:
1. Hilti Inc., HIT-HY 200.
  2. Simpson Strong-Tie, AT-XP.
  3. No substitution permitted.

## 2.7 OTHER MATERIALS

- A. Cement mortar: One part Portland Cement, 2½ parts fine aggregate, and sufficient water to obtain a maximum slump of 6 inches.
- B. Bonding grout: One part cement, one part fine aggregate, and sufficient water to obtain the consistency of thick cream.
- C. Patching mortar: One part cement, 2½ parts fine aggregate, and sufficient water to obtain a maximum slump of 1-inch.
- D. Joint sealants: Comply with Section 07 92 00.
- E. Expansion joint filler material: Asphalt type conforming to the latest requirements of ASTM D994.
- F. Curing and sealing compound: Clear, non-yellowing, water-based, acrylic liquid membrane-forming curing and sealing compound complying with ASTM C1315, Type 1, Class A.
  - 1. Maximum VOC content: 50g/L.
  - 2. Acceptable products:
    - a. W. R. Meadows, VOCOMP-30.
    - b. Or equal.
- G. Dissipating curing compound: Water based, hydrocarbon resin liquid membrane-forming dissipating curing compound complying with ASTM C309, Type 1, Class B.
  - 1. Maximum VOC content: 100 g/L.
  - 2. Acceptable products:
    - a. W. R. Meadows, 1100-CLEAR.
    - b. Or equal.
- H. Provide other materials, not specifically described but required for a complete and proper installation, as selected by the Contractor subject to the approval of the Engineer.

## PART 3 - EXECUTION

### 3.1 SURFACE CONDITIONS

- A. Examine the areas and conditions under which work of this Section will be performed. Correct conditions detrimental to timely and proper completion of the Work. Do not proceed until unsatisfactory conditions are corrected.

### 3.2 FORMS

- A. Design, erect, support, brace, and maintain formwork to safely support vertical and lateral loads until such loads can be supported safely by the concrete structure.

- B. Assemble forms with tight flush joints securely clamped to prevent leakage of mortar. Brace forms to safely support concrete without deformation under load.
- C. Construct forms within the tolerance limits of permissible variations from lines, grades, and dimensions shown on the Drawings, in accordance with ACI 347 "Recommended Practice for Concrete Formwork".
- D. Construct forms to the exact sizes, shapes, lines, and dimensions shown, and as required to obtain accurate alignment, location, grades, and level and plumb work in the finished structure.
- E. Notify the Engineer when formwork is complete so that a proper check may be made at least 24 hours prior to concrete placement.
- F. Carefully remove forms, ensuring complete protection of the structure.
- G. Remove forms for vertical sides of walls, beams, girders, columns, and other similar structural members 24 hours minimum after placement of concrete, provided the concrete has hardened sufficiently and will not be damaged.
- H. Do not remove forms and bracing for slabs, beams, girders, and similar structural members until the concrete structural members have attained sufficient strength to safely support their own weight and any construction or storage load.

### 3.3 REINFORCING

- A. Comply with the following, as well as the specified standards, for details and methods of reinforcing placement and supports.
  - 1. Clean reinforcement and remove loose dust and mill scale, earth, and other materials that reduce bond or destroy bond with concrete.
  - 2. Accurately place and secure reinforcing steel within the tolerances required by ACI 318 using tie bars, chairs, bolsters, wire, clips or other devices approved by the Engineer.
  - 3. Provide plastic protected bar supports for slab reinforcing.
  - 4. Place bar supports for grade beams and slabs on bearing plates or blocks to prevent displacement into the earth subgrade.
  - 5. Place reinforcement to obtain the following clear concrete coverage for protection, within tolerance limits specified in ACI 318 "Building Code Requirements for Structural Concrete":
    - a. Concrete cast against and permanently exposed to earth: 3 inches.
    - b. Concrete exposed to earth, liquid, weather, or bearing on work mat or slabs supporting earth.
      - (1) Slabs and joists: 2 inches.
      - (2) Beams and columns:
        - i. Stirrups, spirals, and ties: 2 inches.
        - ii. Primary reinforcement: 2½ inches.
      - (3) Walls: 2 inches.
      - (4) Footings and base slabs:
        - i. Formed surfaces: 2 inches.

- ii. Top of footings and base slabs: 2 inches.
  - (5) Shells, folded plate members: 1½ inches
- c. Other conditions:
  - (1) Slabs and joists:
    - i. No. 11 bars and smaller: ¾-inch.
    - ii. No. 14 and No. 18 bars: 1½ inches.
  - (2) Beams and columns:
    - i. Stirrups, spirals, and ties: 1½ inches.
    - ii. Primary reinforcement: 2 inches.
  - (3) Walls:
    - i. No. 11 bars and smaller: ¾-inch.
    - ii. No. 14 and No. 18 bars: 1½ inches.
- 6. Provide the following minimum clear distances between parallel reinforcing bars, between adjacent contact splices, and between a contact splice and an adjacent bar:
  - a. Columns: 1½ inches, 1.5 times the bar diameter, or 1.5 times the maximum size of the coarse aggregate, whichever is larger.
  - b. Other elements: 1-inch, one bar diameter, or 1.33 times the maximum size of coarse aggregate, whichever is larger.
- 7. Reinforcing bar splices:
  - a. Use contact lap splices securely tied to adjacent bars and installed with lap lengths shown on the Drawings.
  - b. Stagger splices in adjacent reinforcing bars unless otherwise shown on the drawings or specified:
    - (1) Beams and slabs: Splice bottom bars over supports and top bars at midspan.
  - c. Welded only where shown on the Drawings, conforming to the requirements of AWS D12.1.
- 8. Install welded wire reinforcement in lengths as long as practicable, lapping adjoining pieces two full mesh panels minimum.

### 3.4 EMBEDDED ITEMS

- A. Provide for the proper placement and support of fittings, inserts, fixtures, and sleeves to be built into the concrete work under other sections of the Specifications.
- B. Shop paint non-ferrous metal surfaces of embedded items as described in Section 05 50 00 of these Specifications.

### 3.5 MIXING CONCRETE

- A. Project site batched-mixed concrete:
  - 1. Mix in accordance with ACI 318, Chapter 5.8.1 and 5.8.3.
- B. Ready-mixed concrete:
  - 1. Pre-mix and transport to project site in accordance with ASTM C94.
  - 2. Record time of departure from the mixing plant and batch weights of cement and water on the delivery tickets.

3. Water may be added to the ready-mixed concrete once after delivery, only if the maximum water cement ratio and slump will not be exceeded.
4. Reject concrete not in place within 60 minutes after introducing water to the mix when transported in agitator trucks or within 30 minutes after introducing water to the mix when transported in nonagitator trucks.

### 3.6 PLACING CONCRETE

#### A. Preparation:

1. Remove hardened concrete and foreign material from conveying equipment.
2. Remove foreign matter and excess water accumulated in forms.
3. Rigidly close temporary openings left in formwork.
4. Thoroughly sprinkle earth subgrades for structural slabs without vapor barrier protection to eliminate moisture absorption.
5. Before depositing new concrete on or against concrete which has hardened:
  - a. Thoroughly clean hardened concrete and saturate with water.
  - b. Thoroughly cover hardened concrete surface with a 1/8-inch thick coating of neat cement mortar and place new concrete before the mortar has attained its initial set.
6. Use only clean tools.

#### B. Conveying:

1. Convey concrete from the mixer to place of final deposit as rapidly as practical by methods which will prevent separation or loss of ingredients and assure the required quality of concrete.
2. Deposit concrete as nearly as practicable to its final location to avoid separation due to rehandling and flowing.
3. Do not allow free fall of concrete to exceed 5 feet.
4. Do not use concrete which becomes non-plastic and unworkable, or does not meet required quality control limits, or has been contaminated by foreign materials.
5. Remove rejected concrete from job site.

#### C. Placing concrete in forms:

1. Deposit concrete continuously or in layers so that no concrete will be placed on concrete which has hardened sufficiently to cause cold joints in the work.
2. If necessary, add construction joints, approved by the Engineer.
3. Remove temporary spreaders, screeds, etc. as they become unnecessary.

#### D. Placing concrete slabs:

1. Deposit and consolidate concrete slabs in a continuous operation, within limits of construction joints, until placing of a panel or section is completed.
2. Bring slab surfaces to correct level with a straightedge, and then strike off.
3. Use bullfloats or darbies to smooth the surface, leaving it free of bumps and hollows.
4. Do not sprinkle water on plastic surface. Do not disturb slab surface prior to start of finishing operations.
5. Place beams, girders, brackets, column capitals, haunches, and drop panels integrally with slabs.



- E. Do not begin placement of concrete in supported structural members until concrete previously placed in columns and walls is no longer plastic.

### 3.7 CONSOLIDATION

#### A. General:

1. Consolidate each layer of concrete immediately after placing, by use of mechanical vibrators supplemented by hand spading, rodding, or tamping so that the concrete is thoroughly worked around reinforcement, embedded items, and into corners of the forms, eliminating all air or stone pockets which may cause honeycomb, pitting, or planes of weakness.
2. Use mechanical vibrators with a minimum frequency of 7,000 revolutions per minute.
3. Insert vibrator at points approximately 18 inches apart for approximately 5 to 15 seconds at each point, sufficient to consolidate concrete, but not to cause segregation.
4. Do not overvibrate or use vibrators to transport concrete inside forms.
5. Provide a spare vibrator and auxiliary power source at the site during placement operations.

### 3.8 JOINTS

#### A. Construction joints:

1. Do not relocate construction joints shown on the Drawings or add construction joints, unless approved by the Engineer.
2. Form construction joints perpendicular to main reinforcement and near quarter points of slabs, beams, and girders.
3. Limit spacing of vertical construction joints to 40 feet in any one direction.
4. Locate horizontal wall and column construction joints at the top of footings and grade slabs and the underside of slabs, beams, and girders.
5. Continue reinforcing steel across construction joints as shown on the Drawings or as required by the Engineer.
6. Form keyways in construction joints a minimum of 1½ inches deep and 3½ inches wide unless otherwise shown on the Drawings.
7. Provide the following minimum bearing lengths on concrete walls and columns unless otherwise shown on the Drawings:
  - a. 2 inches for slabs.
  - b. 6 inches for beams and girders.

#### B. Expansion joints:

1. Form expansion joints ½-inch wide with chamfered edges.
2. Fill expansion joints full depth with expansion joint material.
3. Do not permit reinforcement or other embedded metal items that are being bonded with concrete (except dowels in floors bonded on only one side of the joints) to extend continuously through any expansion joint.

#### C. Contraction joints:

1. Sawcut joints: Cut ⅛-inch wide joints to a minimum depth of ¼ the thickness of the slab, but not less than 1-inch. Perform saw cutting within 12 hours of

placement when cutting action will not tear, abrade, or otherwise damage surface and before concrete develops random contraction cracks.

2. Formed joints: Insert preformed plastic or hard board joint strips into the concrete to form 1/8-inch wide joints to a minimum depth of 1-inch.
3. Fully caulk joints with sealant.

### 3.9 CONCRETE FINISHING

- A. Finish concrete work to smooth, clean surfaces of uniform color with no roughness or imperfections.
- B. Remove roughness, projections, honeycomb, and other defects in formed concrete surfaces to sound concrete.
- C. Patch depressions and tie holes immediately after form removal.
  1. Thoroughly wet areas to be patched to prevent absorption of water from patching mortar.
  2. Thoroughly brush bonding grout on areas to be patched.
  3. Consolidate patching mortar into place and strike off to leave a patch slightly higher than surrounding concrete surface to allow for initial shrinkage.
  4. Leave patch area undisturbed for at least one hour before final finishing.
  5. Prepared proprietary compounds for bonding grout and patching mortar may be used in lieu of or in addition to the above patching procedure, if approved by the Engineer.
- D. Unless otherwise shown on the Drawings, provide the following finishes at the indicated locations:
  1. Float finish:
    - a. Monolithic slab surfaces that are to receive trowel finish and other slab finishes specified herein.
  2. Trowel finish:
    - a. Monolithic slab surfaces that are to be exposed to view, unless otherwise shown.
    - b. Slab surfaces that are to be covered with paint.
  3. Non-slip broom finish:
    - a. Walks, stairs, drives, ramps, and similar pedestrian and vehicular areas.
    - b. Apply by dragging coarse bristle broom or burlap belt across concrete with uniform parallel overlapping strokes.
  4. As-formed finish:
    - a. Surfaces adjacent to earth and more than 12 inches below finished grade level.
    - b. Other surfaces not exposed to view.
  5. Smooth rubbed grout finish:
    - a. Exposed concrete surfaces including walls, beams, columns, and other vertical and inclined surfaces.
    - b. Undersides of walkways and slabs.

- c. Surfaces adjacent to earth, stone, sand, or other special media to a depth of 12 inches below the required material grade line or low water level.
- d. Apply finish to freshly hardened concrete as soon as possible after removal of forms.
- e. Apply grout slurry, consisting of one part cement to 1½ parts fine aggregate mixed with water, uniformly over a predampened surface with clean burlap pads or with sponge-rubber or cork floats.
- f. Rub grout surface with carborundum stone or similar abrasive to produce a uniform color and texture.
- g. Remove excess grout with a dry burlap pad or a brush.

### 3.10 CONCRETE CURING

- A. Protect fresh concrete and grout surfaces from premature drying and excessively hot or cold temperatures.
- B. Cure fresh concrete and grout surfaces in a moist condition at a relatively constant temperature for at least 7 days after placement of Type I Portland Cement concrete, or longer if necessary for hydration and proper hardening of the concrete.
- C. Perform curing by one of the following methods:
  - 1. Ponding or continuous water spraying on concrete surface.
  - 2. Covering concrete surfaces with continuously wetted burlap, cotton, or other absorptive mats or fabric.
  - 3. Covering concrete surfaces with impervious waterproof paper or polyethylene film having 4-inch tape-sealed laps at common edges and taped-sealed and weighted perimeter.
  - 4. Applying curing compound on concrete surfaces to which additional concrete will not be bonded in strict accordance with manufacturer's instructions:
    - a. For interior exposed horizontal floors, stairway landings and tread surfaces which will not receive floor covering or other coatings, apply two uniform coats of curing and sealing compound:
      - (1) Apply first coat when the surface water disappears and the concrete surface will not be marred by walking workers.
      - (2) Apply second coat at right angles to the first coat after the first coat has thoroughly dried.
    - b. For all other horizontal surfaces, apply uniform coat of dissipating curing compound when the surface water disappears and the concrete surface will not be marred by walking workers.
    - c. For vertical surfaces, apply uniform coat of dissipating curing compound promptly after removal of forms.
- D. Maintain temperature of fresh concrete between 50 degrees and 70 degrees F for the required curing period.
- E. Provide and erect necessary facilities for heating, covering, insulating, or housing the concrete work for cold weather protection.

### 3.11 CONCRETE TESTING

- A. Provide equipment and services required for sampling and testing concrete.
- B. Include the cost of testing in the total amount of the contract price for concrete work.
- C. Sample concrete in accordance with ASTM C172.
- D. Slump testing:
  - 1. Perform in accordance with ASTM C143.
  - 2. Perform one test minimum for each 50 cubic yards of concrete placed in one operation to check and maintain the required consistency of concrete.
  - 3. Perform whenever required by the Engineer.
- E. Air content testing:
  - 1. Perform concurrently with the taking of the concrete compression test cylinder specimens.
  - 2. Perform in accordance with one of the following methods:
    - a. ASTM C231 pressure method.
    - b. ASTM C173 volumetric method.
    - c. ASTM C138 gravimetric method.
- F. Compression testing:
  - 1. Make and cure compression test cylinder specimens in accordance with ASTM C31.
  - 2. Take one set of four (4) 6-inch x 12-inch cylinders or six (6) 4-inch x 8-inch cylinders for every concrete pour for structural slabs, walls, beams, girders, footings, and columns, and additional sets for each 100 cubic yards of concrete placed in one operation.
  - 3. Take test cylinder specimens as directed by the Engineer to obtain representative samples of the concrete materials.
  - 4. Cure the specimens on the job site under the same field conditions as the concrete work they represent for a minimum of 72 hours after sampling.
  - 5. Test half of each set of concrete test cylinder specimens for compressive strength at 7 days and at 28 days in accordance with ASTM C39 (testing to be performed by an independent testing laboratory approved by the Engineer).
  - 6. In any case where test results of concrete cylinder specimens fail to meet minimum compressive strength requirements, make additional tests in accordance with ASTM C42 or perform load tests in accordance with ACI 318, as required by the Engineer.
  - 7. If these alternate strength tests show that concrete work does not meet minimum strength requirements, remove unsatisfactory concrete and reconstruct the work.

### 3.12 CUTTING AND PATCHING OF EXISTING CONCRETE

- A. Provide neat and smooth finished exposed surfaces.

- B. Provide 1-inch deep (minimum) saw cuts.
- C. Cut off exposed reinforcing bars a minimum of 1½-inch back of finished surface and fill remaining cavity with patching mortar.
- D. Provide straight and square lines at finished openings and ¾-inch chamfers at exposed corners.
- E. Core drill openings for new pipes and conduits and patch with non-shrink grout.
- F. Grind exposed finished surfaces flush to meet and match existing surfaces.

### 3.13 ANCHORING WITH ADHESIVE

- A. Drill holes, prepare surface, dispense and mix adhesive through a static mixing nozzle supplied by the manufacturer, and set reinforcement bars and threaded rod anchors in accordance with the manufacturer's recommendations where shown on the Drawings.
  - 1. Identify position of reinforcing steel and other embedded items prior to drilling holes. Do not cut or damage reinforcing steel, prestressed steel tendons, piping, conduits or other embedded items. Notify the Engineer if reinforcing steel or other embedded items are encountered during drilling.
  - 2. Use rotary impact hammer drills with carbide-tipped bits of diameters as specified by the adhesive manufacturer.
  - 3. Drill holes perpendicular to surface of concrete after has achieved full design strength.
  - 4. Clean holes to remove loose material and drilling dust prior to installation of adhesive.
  - 5. Follow manufacturer's recommendations to ensure proper mixing of adhesive components.
  - 6. Inject adhesive into holes proceeding from the bottom of the hole and progressing toward the surface in such a manner as to avoid introduction of air pockets in the adhesive.
  - 7. Inject sufficient adhesive in the hole to ensure that the annular gap is filled to the surface. Remove excess adhesive from the surface. Shim anchors with suitable device to center the anchor in the hole. Do not disturb or load anchors before manufacturer specified cure time has elapsed.
  - 8. Observe manufacturer's recommendations with respect to installation temperatures.

### 3.14 REMEDIAL WORK

- A. Repair or replace deficient work as directed by the Engineer and at no additional cost to the Owner.

END OF SECTION

SECTION 04 01 00  
MAINTENANCE OF MASONRY

PART 1 - GENERAL

1.1 SUMMARY

- A. Provide maintenance of masonry as shown on the Drawings, as specified herein, and as needed for a complete and proper installation including replacement of existing masonry, pointing and cleaning.
- B. Related work:
  - 1. Documents affecting work of this Section include, but are not necessarily limited to, General Conditions, Supplementary Conditions, and Division 01 - General Requirements of these Specifications.
  - 2. Section 04 20 00, Unit Masonry.

1.2 QUALITY ASSURANCE

- A. Use adequate numbers of skilled workmen who are thoroughly trained and experienced in the necessary crafts and who are completely familiar with the specified requirements and the methods needed for proper performance of the work of this Section.

1.3 DELIVERY, STORAGE, AND HANDLING

- A. Comply with pertinent provisions of Section 01 66 11.

PART 2 - PRODUCTS

2.1 MORTAR

- A. Comply with Section 04 20 00, Unit Masonry.

PART 3 - EXECUTION

3.1 POINTING AND CLEANING

- A. Remove and replace masonry work which is damaged, stained, discolored or otherwise imperfect as directed by the Engineer.
- B. Pointing:
  - 1. Point or cut out and repoint if necessary, all holes and defective joints.
    - a. Cut out and remove loose and disintegrated mortar in joints to sound material.

- b. Dampen joint with water immediately prior to placement of mortar.
  - c. Pack and tool mortar tightly to form a smooth joint.
- C. Cleaning:
- 1. Clean exposed interior and exterior masonry wall surfaces after the mortar has thoroughly set and cured.
  - 2. Secure Engineers approval prior to using any cleaning agents:
    - a. Apply cleaning agent to the sample wall panel or a 10 to 20 square foot section of wall.
    - b. To judge the effectiveness of the cleaning agent the sample will be inspected by the Engineer following a period of not more than 7 days for approval or rejection.
  - 3. Clean all masonry surfaces to be left exposed in the finished work after the mortar has thoroughly set and cured.
    - a. Dry clean masonry surfaces removing large mortar particles and foreign matter.
    - b. Saturate masonry with clean water and flush off all loose mortar and dirt.
    - c. Scrub down walls with a cleaning agent using a stiff fiber brush or wood paddle.
    - d. Thoroughly rinse off all cleaning solution, dirt and mortar crumbs using clean water.
    - e. Protect masonry which may be damaged, stained or discolored during the cleaning process.
    - f. Do not use pure acid, metallic scrapers, or other devices to clean masonry surfaces.

END OF SECTION

## SECTION 04 20 00

## UNIT MASONRY

## PART 1 - GENERAL

## 1.1 SUMMARY

- A. Provide unit masonry as shown on the Drawings, as specified herein, and as needed for a complete and proper installation.
- B. Related work:
  - 1. Documents affecting work of this Section include, but are not necessarily limited to, General Conditions, Supplementary Conditions, and Division 01 - General Requirements of these Specifications.
  - 2. Section 04 01 00, Maintenance of Masonry.

## 1.2 SUBMITTALS

- A. Shop Drawing Submittals:
  - 1. Laboratory testing completed within the last 12 months on concrete masonry units sampled from lots ready for delivery to prove compliance with the specified requirements.
  - 2. Product data: Submit design mixes for mortar and grout including evidence of compliance with ASTM specifications for materials proposed.
  - 3. Detailed reinforcing bar fabrication drawings indicating location of the bar splices proposed in addition to those shown on Drawings.
- B. Comply with pertinent provisions of Section 01 33 01.

## 1.3 QUALITY ASSURANCE

- A. Use adequate numbers of skilled workmen who are thoroughly trained and experienced in the necessary crafts and who are completely familiar with the specified requirements and the methods needed for proper performance of the work of this Section.

## 1.4 DELIVERY, STORAGE, AND HANDLING

- A. Comply with pertinent provisions of Section 01 66 11.
- B. Store masonry units off ground to prevent contamination by mud, dust or materials likely to cause staining or other defects.
- C. Store masonry units above ground on level platforms which allow air circulation under the stacked units.
- D. Cover and protect concrete masonry units against wetting prior to use.



## PART 2 - PRODUCTS

### 2.1 CONCRETE MASONRY UNITS

- A. Provide standard modular size concrete masonry units with uniform texture and color.
- B. Furnish concrete masonry units produced in advance to allow a minimum 28 day cure prior to use.
- C. Where concrete blocks are called for or indicated on the Drawings:
  - 1. Provide hollow concrete masonry units complying with ASTM C90 for load bearing and non-load bearing walls.
- D. Provide accessory shapes as indicated or otherwise required.

### 2.2 MORTAR MATERIALS

- A. General:
  - 1. Water: Provide potable water free from injurious amounts of acids, alkalis, oils, and organic matter.
  - 2. Admixtures: Do not use antifreeze compounds, salts, or admixture.
- B. Concrete masonry units:
  - 1. Portland Cement: Comply with ASTM C150, Type I. "Masonry" cement will not be acceptable.
  - 2. Hydrated lime: Comply with ASTM C207, Type S.
  - 3. Mortar aggregate: Comply with ASTM C144.

### 2.3 GROUT MATERIALS

- A. Grout:
  - 1. Portland Cement: Comply with ASTM C150, Type I. "Masonry" cement will not be acceptable.
  - 2. Hydrated lime: Comply with ASTM C207, type S.
  - 3. Grout aggregate: Comply with ASTM C404.
  - 4. Water: Provide potable water free from injurious amounts of acids, alkalis, oils, and organic matter.
  - 5. Admixtures: Do not use antifreeze compounds, salts, or admixture.

### 2.4 JOINT REINFORCEMENT

- A. Comply with the following:
  - 1. Deformed reinforcement wire: ASTM A496.
  - 2. Wire ties: ASTM A82.
  - 3. Hot dip galvanized coating applied after fabrication:
    - 1. Comply with ASTM A153, Class B.
    - 2. Minimum coating of 1.5 ounces per square foot.

- B. Use prefabricated ladder type horizontal joint reinforcing conforming to ASTM A951 manufactured in 10-foot long sections.
- C. Use prefabricated sections of joint reinforcing at corners and wall intersections to maintain continuity at corners.
- D. Single Wythe Wall Reinforcing:
  1. Provide two parallel longitudinal deformed 9 gauge side rods.
  2. Space longitudinal side rods to allow for 1-inch mortar cover.
  3. Provide 9 gauge cross rods welded at 16-inch intervals to side rods.

## 2.5 REINFORCEMENT

- A. Comply with the following:
  1. Bars: Deformed billet steel conforming to ASTM A615, grade 60, unless otherwise shown on the Drawings.
  2. Tie wire: 16 gauge annealed steel wire.
  3. Rebar positioners: 9 gauge galvanized steel wire.
- B. Fabricate reinforcement in accordance with the latest provisions of ACI 318 "Building Code Requirements for Structural Concrete".
- C. Shop fabricate bars by cold bending to the dimensions and shapes shown on the detail shop drawings unless otherwise shown on the Drawings or approved by the Engineer.
- D. Use bars that are free from paint, oil, dirt, scale, or excessive rust which will destroy or reduce the bond when embedded in grout.

## 2.6 CONTROL JOINT GASKET

- A. Provide factory-extruded solid rubber joint gaskets equal to Dur-O-Wal Rapid Control Joint Rubber Compound manufactured by Dur-O-Wal, Inc.

## 2.7 JOINT SEALANTS

- A. Comply with Section 07 92 00.

## 2.8 BEARING STRIPS

- A. Provide neoprene strips 1-inch wide and ¼-inch thick with a durometer hardness of 50.

## 2.9 LINTELS

- A. Comply with the following:
  1. Steel shapes and plates: ASTM A36.
  2. Painting: Section 09 90 00 of these Specifications.
  3. Welding: AWS Code D1.1.

4. Electrodes for welding: E70XX.
5. Bolts: ASTM A307.

## PART 3 - EXECUTION

### 3.1 PREPARATION

- A. Layout modular masonry coursing to avoid using pieces less than 4 inches long.
- B. Examine the areas and conditions under which work of this Section will be performed. Correct conditions detrimental to timely and proper completion of the Work. Do not proceed until unsatisfactory conditions are corrected.
- C. Foundations:
  1. Do not commence installation until foundations are clean, rough, and level.
  2. Remove laitance, loose aggregate and any foreign material that prevents mortar from bonding to the foundation.
  3. Verify that the foundation elevation is such that the bed joint thickness will be between 1/4-inch and 1/2-inch.

### 3.2 ENVIRONMENT AND PROTECTION

- A. Cold weather requirements: Comply with cold weather construction requirements contained in ACI 530.1/ASCE 6/TMS 602.
  1. Protect masonry work from freezing during cold weather:
  2. Provide enclosures and heating devices to keep the air temperature around the work above 40 degrees F.
  3. Maintain air temperature above 40 degrees F during construction and for 48 hours after work has been completed.
- B. Hot weather requirements: Comply with hot weather construction requirements contained in ACI 530.1/ASCE 6/TMS 602.
- C. Cover unfinished masonry work for protection when work is stopped at the end of the day.

### 3.3 MORTAR MIXING

- A. General:
  1. Measure ingredients accurately.
  2. Prepare mortar in accordance with C270 to produce a workable dense mixture.
  3. Preheat water and aggregate when necessary to produce a mortar temperature above 40 degrees F.
  4. Do not retemper mortar after initial set occurs.
  5. Discard and do not use mortar which is unused after 1½ hours following initial mixing.

6. Add color pigment to mortar mix in accordance with manufacturer's recommendations.

- B. Provide type N mortar consisting of:
  1. One part Portland Cement; to
  2. One part hydrated lime; to
  3. Six parts mortar aggregate measured damp and loose.

### 3.4 GROUT MIXING

- A. General:
  1. Measure ingredients accurately.
  2. Prepare mortar in accordance with C476 to produce a workable dense mix having slump of 8 to 11 inches.
  3. Discard and do not use mortar which is unused after 1½ hours following initial mixing.
- B. Provide fine grout consisting of:
  1. One part Portland Cement; to
  2. One-tenth part hydrated lime; to
  3. Three parts grout aggregate.

### 3.5 INSTALLATION

- A. Laying:
  1. General:
    1. Unless otherwise indicated on the Drawings, make the masonry work plumb, level, and true to line, with square angles and corners.
    2. Construct masonry such that all exposed surfaces are free from chips, pinholes and other imperfections.
    3. Use masonry that is clean and free from dust and other foreign matter.
    4. Spalled, cracked or broken pieces of masonry can be used as backup where concealed.
    5. Lay in running bond unless otherwise shown on the Drawings.
    6. Tothing of masonry is not acceptable.
    7. Completely fill mortar joints to provide a watertight surface.
    8. Use a carborundum saw to make straight, smooth, sharp edges when cutting masonry.
    9. Where mortar has moved or shifted, remove and lay again in fresh mortar.
    10. Build anchors, grounds, inserts, frames, thimbles, brackets, nailers, flashing, lintels, bearing plates and other items into the masonry as work progresses.
    11. Construct masonry such that the fit around windows, doors, panels, cut-out cabinets and openings is close and neat.
    12. Set sills and ends of lintels in full mortar beds.
    13. Use standard units to provide square internal corners and lintel edges.

14. Immediately remove mortar and grout from areas where they are not scheduled to be placed.

- B. Concrete masonry units:
1. Use only dry concrete masonry units.
  2. Provide 3/8-inch mortar joints.
  3. Provide fully grouted units for the top course of walls except where noted on the Drawings.
  4. Use bullnose units for external corners and jambs.
- C. Control joints:
1. Provide vertical control joints at intervals of not more than 48 horizontal feet of continuous exterior wall unless otherwise shown on the Drawings.
  2. Extend control joint completely through masonry wall section.
  3. Provide control joint gasket between concrete masonry units.
  4. Provide smooth dowel bar with dowel cap between fully grouted concrete masonry bond beam units.
  5. Fill the joint opening on each side of masonry wall with joint sealant.
- D. Joint reinforcing:
1. Place horizontal joint reinforcing in every second course of masonry walls.
  2. Place horizontal joint reinforcing in the first and second course above and below openings.
  3. Extend joint reinforcing not less than 24 inches beyond each side of opening.
  4. Place prefabricated sections of joint reinforcing at corners and wall intersections to maintain continuity at corners.
  5. Lap joint reinforcing a minimum of 6 inches at splice locations.
  6. Do not extend joint reinforcing through vertical masonry control joints or isolation joints.
- E. Reinforcement:
1. Provide reinforcement as shown on the Drawings, fully embedded in grout and not in mortar or mortar joints.
  2. Provide required metal accessories to ensure adequate alignment of steel during grouting operations.
- F. Bearing strips:
1. Attach bearing strips to the top of loadbearing walls which support a cast in place concrete slab.
  2. Position bearing strip such that it is flush with the interior face of the masonry wall.

### 3.6 JOINERY

- A. General: On all joints exposed to the weather, tool and make smooth, solid, and watertight.
- B. Joint Pattern:
1. Provide a smooth uniform concave tooled mortar surface without voids for exposed areas.

2. Provide struck joints for all other areas.

### 3.7 GROUTING

#### A. Placement:

1. Place grout within 1½ hours from introducing water in the mixture and prior to initial set.
2. Comply with maximum grout pour height and minimum grout space dimensions for grouting cells of hollow units for fine grout per Table 7 of ACI 530.1 Specification for Masonry Structures, latest edition.
3. Limit grout lifts to maximum height of 5 feet.
4. Provide cleanouts for grout pours over 5 feet. Locate cleanout openings in face shells of bottom course units containing dowels or vertical reinforcing and at maximum spacing of 32 inches for solidly grouted walls.
5. Verify that vertical and horizontal reinforcement is in proper position and adequately secured before beginning pours.
6. Place each grout pour continuously and consolidate immediately. Do not interrupt placements more than 1½ hours.
7. Level off grout 1-inch below top of bed joint to create shear key between grout lifts.
8. Place grout for spanning elements in single, continuous pour.

#### B. Consolidation:

1. Consolidate grout placements 12 inches or less in height by mechanical vibration or by puddling.
2. Consolidate grout placements exceeding 12 inches in height by mechanical vibration and reconsolidate by mechanical vibration after initial water loss and settlement has occurred.
3. Do not overconsolidate.

### 3.8 LINTELS

- A. Provide 8-inch bearing at each end.
- B. Grout cores of block below ends of lintel steel bearing on masonry.
- C. Above window openings, bolt back to back lintel angles together with window frame fins inserted between the angle legs.

END OF SECTION

SECTION 05 50 00  
METAL FABRICATIONS

PART 1 - GENERAL

1.1 SUMMARY

- A. Provide miscellaneous metal work as shown on the Drawings, as specified herein, and as needed for a complete and proper installation.
- B. Related work:
  - 1. Documents affecting work under this Section include, but are not necessarily limited to, General Conditions, Supplementary Conditions, and Division 01 - General Requirements of these Specifications.
  - 2. See specification Section 33 16 19.33, Concrete/Steel Composite Water Storage Tank for specific information regarding metal fabrication requirements for the water storage tank, which may exceed the requirements of this section.
- C. References:
  - 1. Reserved.

1.2 SUBMITTALS

- A. Shop Drawing Submittals – None Required.
- B. Operation and Maintenance Manuals – None Required.
- C. Certificates and Guarantees – None Required.
- D. Lubricants – None Required.
- E. Spare Parts – None Required.
- F. Comply with pertinent provisions of Section 01 33 01.

1.3 QUALITY ASSURANCE

- A. Perform shop and/or field welding required in connection with the work of this Section in strict accordance with pertinent recommendations of the American Welding Society.
  - 1. Structural Welding Code Steel: D1.1.
  - 2. Structural Welding Code Aluminum: D1.2.
  - 3. Structural Welding Code Sheet Steel: D1.3.
  - 4. Structural Welding Code Stainless Steel: D1.6.

#### 1.4 DELIVERY, STORAGE, AND HANDLING

- A. Comply with pertinent provisions of Section 01 66 11.

#### 1.5 SITE CONDITIONS – Reserved.

#### 1.6 MAINTENANCE – Reserved.

### PART 2 - PRODUCTS

#### 2.1 MATERIALS

- A. In fabricating items which will be exposed to view, limit materials to those which are free from surface blemishes, pitting, rolled trade names, and roughness.
- B. Comply with pertinent provisions of the following standards, latest edition.
1. Aluminum castings: ASTM B26.
  2. Aluminum sheet and plate: ASTM B209, Alloy 6061-T6.
  3. Aluminum drawn seamless tubes: ASTM B210, Alloy 6063-T5.
  4. Aluminum extrusions: ASTM B221, Alloy 6063-T6.
  5. Aluminum seamless pipe: ASTM B241, Alloy 6061-T6.
  6. Aluminum forgings: ASTM B247, Alloy 6061-T6.
  7. Aluminum structural shapes: ASTM B308, Alloy 6061-T6.
  8. Aluminum structural pipe and tube: ASTM B429, 6061-T6.
  9. Aluminum tread plate: ASTM B632, Alloy 6061-T6.
  10. Steel W-shapes: ASTM A992.
  11. Steel M-shapes, S-shapes, C-shapes, MC shapes: ASTM A36.
  12. Steel rectangular and round hollow structural sections (HSS): ASTM A500, Grade B.
  13. Steel angles, plates, and bars: ASTM A36.
  14. Steel plates to be bent or cold-formed: ASTM A283, Grade C.
  15. Cold-finished steel bars: ASTM A108.
  16. Cold-rolled carbon steel sheets: ASTM A1008.
  17. Galvanized carbon steel sheets: ASTM A653, with G90 zinc coating.
  18. Stainless steel bars, angles and shapes: ASTM A276, Type 316 (Type 316L for welded connections).
  19. Welded stainless steel mechanical tubing: ASTM A554, Type 316 (Type 316L for welded connections).
  20. Stainless steel fasteners: ASTM F593 and F594, Type 316.
  21. Stainless steel wire fabric, sheet and plates: ASTM A240, Type 316 (Type 316L for welded connections).
  22. Gray iron castings: ASTM A48.
  23. Malleable iron castings: ASTM A47.
  24. Steel pipe: ASTM A53, Grade B, Schedule 40, black finish unless otherwise noted.
  25. Concrete inserts: Threaded or wedge type galvanized ferrous castings of malleable iron complying with ASTM A27.



## 2.2 ANCHORS AND FASTENERS

- A. Provide Type 316 stainless steel anchor bolts, threaded rods, bolts, nuts, screws, staples, washers, rivets, lock nuts, nails, pins, hooks, clamps, and all other metal fasteners.
- B. Post installed mechanical anchors:
  - 1. Provide Type 316 stainless steel wedge, sleeve and drop-in expansion anchors of size and number required for the particular use.
  - 2. Furnish anchors suitable for installation in cracked and uncracked base materials to resist short and long-term sustained loading.
  - 3. Acceptable manufacturers:
    - a. Simpson Strong-Tie Company, Inc.
    - b. Hilti, Inc.
    - c. ITW Redhead.
    - d. Or equal.
- C. Post installed adhesive anchors:
  - 1. Provide Type 316 stainless steel threaded rods set in place with a cartridge type, two-component, high solids adhesive system dispensed and mixed through a static mixing nozzle supplied by the manufacturer.
  - 2. Concrete base material: Furnish material suitable for anchorage of threaded rods in cracked and uncracked concrete to resist long-term sustained loading, tested and qualified in accordance with the International Code Council Acceptance Criteria for Post-installed Adhesive Anchors in Concrete Elements (AC308).
    - a. Acceptable products:
      - (1) Hilti Inc., HIT-HY 200.
      - (2) Simpson Strong-Tie, AT-XP.
      - (3) No substitution permitted.
  - 3. Solid grouted masonry base material: Furnish material suitable to resist long-term sustained loading, tested and qualified in accordance with the International Code Council Acceptance Criteria for Adhesive Anchors in Concrete and Masonry Elements (AC58).
    - a. Acceptable products:
      - (1) Hilti Inc., HIT-HY 70.
      - (2) Simpson Strong-Tie, ET HP.
      - (3) No substitution permitted.
  - 4. Hollow masonry base material: Furnish material suitable to resist long-term sustained loading, tested and qualified in accordance with the International Code Council Acceptance Criteria for Adhesive Anchors in Unreinforced Masonry Elements (AC60). Provide screen tubes for anchorage of threaded rods in hollow concrete masonry, hollow brick masonry and unreinforced masonry applications.
    - a. Acceptable products:
      - (1) Hilti Inc., HIT-HY 70.
      - (2) Simpson Strong-Tie, ET HP.
      - (3) No substitution permitted.

- D. Provide Type 304 stainless steel screw anchors of size and number required for the particular use.
  - 1. Acceptable products:
    - a. Powers Fasteners, Tapper Screw Anchor.
    - b. Or equal.

### 2.3 OTHER MATERIALS

- A. Provide other materials, not specifically described but required for a complete and proper installation, as selected by the Contractor subject to the approval of the Engineer.

### 2.4 FABRICATION

- A. Except as otherwise shown on the Drawings or the approved Shop Drawings, use materials of size, thickness, and type required to produce reasonable strength and durability in the work of this Section.
- B. Fabricate with accurate angles and surfaces which are true to the required lines and levels, grinding exposed welds smooth and flush, forming exposed connections with hairline joints, and using concealed fasteners wherever possible.
- C. Prior to shop painting or priming, properly clean metal surfaces as required for the applied finish and for the proposed use of the item.
- D. On surfaces inaccessible after assembly or erection, apply two coats of the specified primer. Change color of second coat to distinguish it from the first.

### 2.5 CAST IRON FRAMES AND COVERS

- A. Provide gray cast iron frames and covers as follows unless otherwise indicated on the Drawings.
  - 1. Adjusting grade rings: Neenah R-1979, Type A, or equal.
- B. Provide machined bearing surfaces for all frames, covers, grates, and adjusting rings.

### 2.6 MANHOLE STEPS

- A. Provide steps with a minimum width of 12 inches and a minimum projection of 5 inches.
  - 1. Use steps consisting of copolymer polypropylene plastic with continuous 1/2-inch steel reinforcement as manufactured by M.A. Industries, Inc., or cast iron steps, Neenah R-1980-I, or equal.

## 2.7 ALUMINUM LADDERS AND STAIRS

- A. Fabricate of structural shapes in accordance with details shown on the Drawings.
  - 1. Provide stainless steel bolts, nuts, washers, and other fasteners.
  - 2. Stairway treads: Pressure locked rectangular bar type with corrugated nosing.
  - 3. Acceptable manufacturers:
    - a. Breuer Metal Craftsmen, Beaver Dam, WI.
    - b. Or equal.

## 2.8 SUPPORT AND SAFETY CHAINS

- A. Provide 1/4-inch size stainless steel proof coil type chains.
  - 1. Use stainless steel snaps, eye bolts, hooks, swivels, and turnbuckles.

## PART 3 - EXECUTION

### 3.1 SHOP TREATMENT OF METAL SURFACES

- A. Clean ferrous metal surfaces, except stainless steel and work to be galvanized, by sandblasting to bare metal in accordance with the Steel Structures Painting Council Specifications (SSPC) SP-10 and shop prime as specified under the Section 09 90 00.
  - 1. Do not shop prime or paint contact surfaces which are to be field bolted or welded.
- B. Clean cast iron surfaces by sandblasting to bare metal in accordance with SSPC SP-6 and shop paint with a two-coat system of bituminous paint using Tnemec 46-465 Heavy Duty Black, or equal.
- C. Clean stainless steel surfaces to remove oil, grease, hand and finger prints, and any other surface contaminants after fabrication and passivate in a 20 percent nitric acid solution.
  - 1. Protect polished stainless steel surfaces with removable plastic coatings or coverings during delivery, handling, and installation.
- D. Provide standard mill finish for aluminum surfaces unless clear anodized or color finish is otherwise specified.
  - 1. Provide caustic etch and anodic oxide treatment for aluminum surfaces to be anodized, conforming to the Aluminum Association Standard AA-M12C22A.
- E. Properly clean copper and bronze metal surfaces and shop coat with a high quality clear finishing lacquer.

- F. Shop paint non-ferrous metal surfaces which will contact dissimilar metals, mortar, concrete, plaster, or any other corrosive material with one heavy coat of bituminous paint, using Tnemec 46-465, or equal.

### 3.2 COORDINATION

- A. Coordinate as required with other trades to assure proper and adequate provision in the work of those trades for interface with the work of this Section.

### 3.3 INSTALLATION

#### A. General:

1. Set work accurately into position, plumb, level, true, and free from rack.
2. Anchor firmly into position.
3. Where field welding is required, comply with AWS recommended procedures of manual-shielded metal-arc welding for appearance and quality of weld and for methods to be used in correcting welding work.
4. Grind exposed welds smooth and touch-up shop prime coats.
5. Do not cut, weld, or abrade surfaces which have been hot-dip galvanized after fabrication and which are intended for bolted or screwed field connections.
6. Immediately after erection, clean the field welds, bolted connections, and abraded areas of shop priming. Paint the exposed areas with same material used for shop priming.

#### B. Post installed anchors:

1. Perform anchor installation in accordance with manufacturer's instructions.
2. Identify location of reinforcing steel and other embedded items prior to drilling holes for anchors. Do not cut or damage reinforcing steel, prestressed steel tendons, piping, conduits or other embedded items. Notify the Engineer of reinforcing steel or other embedded items encountered during drilling.
3. Use drill type, bit type and diameter recommended by the anchor manufacturer.
4. Drill holes perpendicular to surface of concrete or masonry after concrete, mortar or grout has achieved full design strength.
5. Clean holes to remove loose material and drilling dust prior to installation of anchors.
6. Mechanical anchors:
  - a. Protect threads from damage during anchor installation.
  - b. Use a torque wrench to set anchors to manufacturer's recommended torque.
7. Adhesive anchors:
  - a. Install screen tubes for anchorage of threaded rods in hollow masonry base materials.
  - b. Follow manufacturer's recommendations to ensure proper mixing of adhesive components.

- c. Inject adhesive into holes proceeding from the bottom of the hole and progressing toward the surface in such a manner as to avoid introduction of air pockets in the adhesive.
  - d. Inject sufficient adhesive in the hole to ensure that the annular gap is filled to the surface. Remove excess adhesive from the surface. Shim anchors with suitable device to center the anchor in the hole. Do not disturb or load anchors before manufacturer's specified cure time has elapsed.
  - e. Observe manufacturer's recommendations with respect to installation temperatures.
8. Provide the following minimum embedment, edge distance and spacing unless indicated otherwise by the anchor manufacturer's instructions or shown otherwise on the Drawings:

Anchor Type	Min Embedment (Bolt Diameters)	Min Edge Distance (Bolt Diameters)	Min Spacing (Bolt Diameters)
Wedge	9	6	10
Sleeve	4	6	12
Drop-In	4	6	12
Adhesive	9	9	14

END OF SECTION

SECTION 06 10 00  
ROUGH CARPENTRY

PART 1 - GENERAL

1.1 SUMMARY

- A. Provide wood, nails, bolts, screws, framing anchors, miscellaneous hardware and other items needed to perform carpentry for construction shown on the Drawings, as specified herein, and as needed for a complete and proper installation.
- B. Related work:
  - 1. Documents affecting work of this Section include, but are not necessarily limited to, General Conditions, Supplementary Conditions, and Division 01 - General Requirements of these Specifications.
- C. References:
  - 1. Reserved.

1.2 SUBMITTALS

- A. Shop Drawing Submittals – Comply with pertinent provision of Section 01 33 01.
- B. Operation and Maintenance Manuals – Comply with pertinent provisions of Section 01 78 26.

1.3 QUALITY ASSURANCE

- A. Use adequate numbers of skilled workmen who are thoroughly trained and experienced in the necessary crafts and who are completely familiar with the specified requirements and the methods needed for proper performance of the work of this Section.
- B. Comply with the pertinent codes and regulations of governmental agencies having jurisdiction.
- C. Comply with pertinent provisions of the following codes and standards:
  - 1. American Wood Council (AWC): National Design Specifications for Wood Construction, ANSI/AF&PA NDS-latest edition.
  - 2. National Institute of Standards and Technology:
    - a. American Softwood Lumber Standard, PS 20-latest edition.
    - b. Standard for Construction and Industrial Plywood, PS 1-latest edition.
  - 3. American Lumber Standards Committee (ALSC): National Grading Rule.
  - 4. American Plywood Association (APA): Grades and Specifications.
  - 5. American Wood Preservers Association (AWPA):
    - a. Lumber, Timber, Bridge Ties and Mine Ties -- Pressure Treatment, AWPA C2-latest edition.

- b. Plywood Pressure Treatment, AWPA C9-latest edition.

#### 1.4 DELIVERY, STORAGE, AND HANDLING

- A. Comply with pertinent provisions of Section 01 66 11.
- B. Deliver the materials to the job site and store, in a safe area, out of the way of traffic, and shored up off the ground surface.
- C. Identify framing lumber as to grades, and store each grade separately from other grades.
- D. Use extreme care in off loading of lumber to prevent damage, splitting and breaking of materials.
- E. Protect metals with adequate waterproof outer wrapping.

#### 1.5 METAL FRAMING MATERIAL OPTIONS

- A. Where noted on drawings, metal framing meeting size and structural properties of wood framing shall be utilized.

### PART 2 - PRODUCTS

#### 2.1 GRADE STAMPS

- A. Identify framing lumber by the grade stamp of the National Lumber Grades Authority (NLGA), or such other grade stamp as is approved in advance by the Engineer.
- B. Identify plywood as to species, grade, and glue type by the stamp of the American Plywood Association (APA).
- C. Identify other materials of this Section by the appropriate stamp of the agency approved in advance by the Engineer.

#### 2.2 MATERIALS

- A. Provide materials in the quantities needed for the Work shown on the Drawings, and meeting or exceeding the following standards of quality:
  - 1. Framing lumber for studs, plates, rafters, beams, and joists: Douglas Fir-Larch or Spruce-Pine-Fir, Grade No. 2 or better.
  - 2. Plywood: APA EXT Grade C-D or better.
  - 3. Finish lumber for trim: Grade C Select White Pine, thoroughly seasoned or kiln dried, and uniform in color.
  - 4. Rough hardware:
    - a. Steel items: Comply with ASTM A36.
    - b. Bolts: Comply with ASTM A307.
    - c. Lag screws: Comply with ASTM A307.

- d. Nails: Use common except as otherwise noted.
- e. Connectors: Simpson, Teco, or equal as approved by the Engineer.
- f. Provide ASTM A653, G185 hot dip galvanized coating for rough hardware at exposed exterior locations or at locations in contact with treated wood.
  - (1) Steel items, bolts, lag screws and nails: Comply with ASTM A153.
  - (2) Connectors: Comply with ASTM A123.

B. Treated wood:

- 1. Provide pressure treated lumber and plywood where shown on the Drawings.
- 2. Pressure treat above ground wood members in contact with concrete or masonry with waterborne alkaline copper quaternary (ACQ) preservative system containing no arsenic and no chromium to a minimum retention of 0.25 lb./cu.ft.
- 3. Pressure treat wood members in contact with ground or fresh water with waterborne alkaline copper quaternary (ACQ) preservative system containing no arsenic and no chromium to a minimum retention of 0.45 lb./cu.ft.
- 4. Kiln dry all wood to a 19 percent maximum moisture content before and after pressure treatment.

## 2.3 OTHER MATERIALS

- A. Provide other materials, not specifically described but required for a complete and proper installation, as selected by the Contractor subject to the approval of the Engineer.

## 2.4 FRP WALL AND CEILING PANEL

- A. Provide FRP wall and ceiling panels consisting of FRP laminate and wood substrate.
- B. Laminates shall be uniform in color and be of Class C fire protection. Owner to select color and texture from manufacturer's standard colors and texture.
- C. Wood substrate shall be of minimum 5/8-inch thickness and adequately supported between wall or ceiling studs.
- D. Provide manufacturers fasteners and fabricated edge and corner connecting pieces to provide for a completely finished product.

## PART 3 - EXECUTION

### 3.1 SURFACE CONDITIONS

- A. Examine the areas and conditions under which work of this Section will be performed. Correct conditions detrimental to timely and proper completion of the Work. Do not proceed until unsatisfactory conditions are corrected.



### 3.2 DELIVERIES

- A. Stockpile materials sufficiently in advance of need to assure their availability in a timely manner for this Work.
- B. Make as many trips to the job site as are needed to deliver materials of this Section in a timely manner to ensure orderly progress of the Work.

### 3.3 COMPLIANCE

- A. Do not permit materials not complying with the provisions of this Section to be brought onto or to be stored at the job site.
- B. Promptly remove non-complying materials from the job site and replace with materials meeting the requirements of this Section.

### 3.4 WORKMANSHIP

- A. Produce joints which are tight, true, and well nailed, with members assembled in accordance with the Drawings and with pertinent codes and regulations.
- B. Finish trim jointing:
  - 1. Make joints to conceal shrinkage; miter exterior joints; cope interior joints; miter or scarf end-to-end joints.
  - 2. Install trim in pieces as long as possible, jointing only where solid support is obtained.
- C. Selection of lumber pieces:
  - 1. Carefully select the members.
  - 2. Select individual pieces so that knots and obvious defects will not interfere with placing bolts or proper nailing, and will allow making of proper connections.
  - 3. Cut out and discard defects which render a piece unable to serve its intended function.
  - 4. Lumber may be rejected by the Engineer, whether or not it has been installed, for excessive warp, twist, bow, crook, mildew, fungus, or mold, as well as for improper cutting and fitting.
- D. Do not shim any framing component.

### 3.5 GENERAL FRAMING

- A. General:
  - 1. In addition to framing operations normal to the fabrication and erection indicated on the Drawings, install wood blocking and backing required for the work of other trades.
  - 2. Set horizontal and sloped members with crown up.

3. Do not notch, cut, or bore members for pipes, ducts, or conduits, or for other reasons except as shown on the Drawings or as specifically approved in advance by the Engineer.

B. Bearings:

1. Make bearings full unless otherwise indicated on the Drawings.
2. Finish bearing surfaces on which structural members are to rest so as to give sure and even support.
3. Where framing members slope, cut or notch the ends as required to give uniform bearing surface.

### 3.6 BLOCKING AND BRIDGING

- A. Install blocking as required to support items of finish and to cut off concealed draft openings, both vertical and horizontal, between ceiling and floor areas.

B. Bridging:

1. Install wood cross bridging (not less than 2" x 3" nominal), metal cross bridging of equal strength, or solid blocking between joists where the span exceeds 8' - 0".
2. Provide maximum distance of 8' - 0" between a line of bridging and a bearing.
3. Cross bridging may be omitted for roof and ceiling joists where the omission is permitted by code, except where otherwise indicated on the Drawings.
4. Install solid blocking between joists at points of support and wherever sheathing is discontinuous. Blocking may be omitted where joists are supported on metal hangers.

### 3.7 ALIGNMENT

- A. On framing members to receive a finished surface, align the finish subsurface to vary not more than 1/8-inch from the plane of surfaces of adjacent furring and framing members.

### 3.8 INSTALLATION OF PLYWOOD SHEATHING

A. Placement:

1. Place plywood with face grain perpendicular to supports and continuously over at least two supports, except where otherwise shown on the Drawings.
2. Center joints accurately over supports, unless otherwise shown on the Drawings.

- B. Protect plywood from moisture by use of waterproof coverings until the plywood in turn has been covered with the next succeeding component or finish.

### 3.9 FASTENING OF FRAMING LUMBER

A. Nailing:

1. Provide penetration into the piece receiving the point of not less than 1/2 the length of the nail or spike, provided, however, that 16d nails may be used to connect two pieces of 2-inch (nominal) thickness.

2. Nail without splitting wood.
  3. Prebore as required.
  4. Remove split members and replace with members complying with the specified requirements.
- B. Bolting:
1. Drill holes 1/16-inch larger in diameter than the bolts being used.
  2. Drill straight and true from one side only.
  3. Do not bear bolt heads on wood, but use washers under head and nut where both bear on wood, and use washers under all nuts.
- C. Screws:
1. For lag screws and wood screws, prebore holes same diameter as root of threads, enlarging holes to shank diameter for length of shank.

### 3.10 FASTENING OF TRIM

- A. Install items straight, true, level, plumb, and firmly anchored in place.
- B. Where blocking or backing is required, coordinate as necessary with other trades to ensure placement of required backing and blocking in a timely manner.
- C. Nail trim with finish nails of proper dimension to hold the member firmly in place without splitting the wood.
- D. Nail exterior trim with galvanized nails, making joints to exclude water and setting in waterproof glue or the sealant.
- E. On exposed work, set nails for putty.
- F. Screw, do not drive, wood screws; except that screws may be started by driving and then screwed home.

### 3.11 FINISHING

- A. Sandpaper finished wood surfaces thoroughly as required to produce a uniformly smooth surface, always sanding in the direction of the grain; except do not sand wood which is designed to be left rough.
- B. No coarse grained sandpaper mark, hammer mark, or other imperfection will be accepted.

END OF SECTION

SECTION 07 21 00  
THERMAL INSULATION

PART 1 - GENERAL

1.1 SUMMARY

- A. Provide building insulation as shown on the Drawings, as specified herein, and as needed for a complete and proper installation.
- B. Related work:
  - 1. Documents affecting work under this Section include, but are not necessarily limited to, General Conditions, Supplementary Conditions, and Division 01 - General Requirements of these Specifications.
- C. References:
  - 1. Reserved.

1.2 SUBMITTALS

- A. Shop Drawing Submittals – None Required.
- B. Operation and Maintenance Manuals – None Required.
- C. Certificates and Guarantees – None Required.
- D. Lubricants – None Required.
- E. Spare Parts – None Required.

1.3 QUALITY ASSURANCE – Reserved.

1.4 DELIVERY, STORAGE, AND HANDLING

- A. Comply with pertinent provisions of Section 01 66 11.

1.5 SITE CONDITIONS – Reserved.

1.6 MAINTENANCE – Reserved.

PART 2 - PRODUCTS

2.1 MASONRY INSULATION

- A. Block core fill:
  - 1. Provide two component foam insulation systems consisting of aminoplast resin and a catalyst foaming agent surfactant.

2. Acceptable product:
  - a. Core-Fill 500, Tailored Chemical Products, Inc.
  - b. Or equal.

## 2.2 WALL BOARD INSULATION

- A. Provide rigid extruded polystyrene foam insulation in sheets.
  1. Thickness: Two layers of 2-inch minimum.
  2. Acceptable products:
    - a. Thermax Heavy Duty Insulation by Dow Chemical Company.
    - b. Or equal.

## 2.3 WATER MAIN INSULATION

- A. Provide rigid extruded polystyrene foam insulation in sheets.
  1. Thickness: 2-inch minimum.
  2. Minimum compressive strength of 40 psi.
  3. Acceptable products:
    - a. Styrofoam HI-40 by Dow Chemical Company.
    - b. Or equal

## PART 3 - EXECUTION

### 3.1 INSTALLATION

- A. Building Insulation: Install in strict accordance with the building insulation manufacturer's recommended installation procedures, anchoring all components firmly into place.

END OF SECTION

SECTION 07 60 00  
FLASHING AND SHEET METAL

PART 1 - GENERAL

1.1 SUMMARY

- A. Provide flashing and sheet metal not specifically described in other Sections of these Specifications but required to prevent penetration of water through the exterior wall of the building.
- B. Related work:
  - 1. Documents affecting work of this Section include, but are not necessarily limited to, General Conditions, Supplementary Conditions, and Division 01 - General Requirements of these Specifications.
- C. References:
  - 1. Reserved.

1.2 SUBMITTALS

- A. Shop Drawing Submittals:
  - 1. Copings and gravel stops, including layout and manufacturer's catalog cuts.
- B. Operation and Maintenance Manuals – None Required.
- C. Certificates and Guarantees – None Required.
- D. Lubricants – None Required.
- E. Spare Parts – None Required.

1.3 QUALITY ASSURANCE

- A. In addition to complying with pertinent codes and regulations, comply with pertinent recommendations contained in current edition of "Architectural Sheet Metal Manual" published by the Sheet Metal and Air conditioning Contractors National Association (SMACNA).
- B. Standard commercial items may be used for flashing, trim, reglets, and similar purposes provided such items meet or exceed the quality standards specified.

1.4 DELIVERY, STORAGE, AND HANDLING

- A. Comply with pertinent provisions of Section 01 66 11.

1.5 SITE CONDITIONS – Reserved.

1.6 MAINTENANCE – Reserved.

PART 2 - PRODUCTS

2.1 METAL FLASHINGS AND COUNTER-FLASHINGS

- A. Fabricate of Type 304 stainless steel sheets of not less than 0.015-inch thickness in accordance with the manufacturer's recommendations and instructions pertaining to overlappings distance, method of soldering, bending and crimping, provisions for expansion and other construction details.

2.2 OTHER MATERIALS

- A. Provide other materials, not specifically described but required for a complete and proper installation.

PART 3 - EXECUTION

3.1 WORKMANSHIP

- A. General:
  - 1. Form sheet metal accurately and to the dimensions and shapes required, finishing molded and broken surfaces with true, sharp, and straight lines and angles and, where intercepting other members such as at a building corner, coping to an accurate fit and soldering or welding securely.
  - 2. Unless otherwise specifically permitted by the Engineer, turn exposed edges back 1/2-inch.
- B. Form, fabricate, and install sheet metal so as to adequately provide for expansion and contraction in the finished Work.
- C. Weatherproofing:
  - 1. Finish watertight and weathertight where so required.
  - 2. Make lock seam work flat and true to line, sweating full of solder.
  - 3. Make lock seams and lap seams, when soldered, at least ½-inch wide.
  - 4. Where lap seams are not soldered, lap according to pitch, but in no case less than 3 inches.
  - 5. Make flat and lap seams in the direction of flow.
- D. Joints:
  - 1. Join parts with rivets or sheet metal screws where necessary for strength and stiffness.
  - 2. Provide suitable watertight expansion joints for runs of more than 40'-0", except where closer spacing is indicated on the Drawings or required for proper installation.

- E. Nailing:
  - 1. Whenever possible, secure metal by means of clips or cleats, without nailing through the exterior metal.
  - 2. In general, space nails, rivets, and screws not more than 8 inches apart and, where exposed to the weather, use lead washers.
  - 3. For nailing into wood, use barbed roofing nails 1¼ inches long by 11 gauge.
  - 4. For nailing into concrete, use drilled plugholes and plugs.

### 3.2 SOLDERING

- A. General:
  - 1. Thoroughly clean and tin the joint materials prior to soldering.
  - 2. Perform soldering slowly, with a well heated copper, in order to heat the seams thoroughly and to completely fill them with solder.
  - 3. Perform soldering with a heavy soldering copper of blunt design, properly tinned for use.
  - 4. Make exposed soldering on finished surfaces neat, full flowing, and smooth.
- B. After soldering, thoroughly wash acid flux with a soda solution.

### 3.3 TESTS

- A. Upon request of the Engineer, demonstrate by hose or standing water that the flashing and sheet metal are completely watertight.

END OF SECTION



SECTION 07 92 00

JOINT SEALANTS

PART 1 - GENERAL

1.1 SUMMARY

- A. Provide joint sealants as shown on the Drawings, as required by other Sections, as specified herein, and as needed for a complete and proper installation.
- B. Related work:
  - 1. Documents affecting work of this Section include, but are not necessarily limited to, General Conditions, Supplementary Conditions, and Division 01 – General Requirements of these Specifications.
- C. References:
  - 1. Reserved.

1.2 SUBMITTALS

- A. Shop Drawing Submittals – None Required.
- B. Operation and Maintenance Manuals – None Required.
- C. Certificates and Guarantees – None Required.
- D. Lubricants – None Required.
- E. Spare Parts – None Required.

1.3 QUALITY ASSURANCE

- A. Use adequate numbers of skilled workmen who are thoroughly trained and experienced in the necessary crafts and who are completely familiar with the specified requirements and the methods needed for proper performance of the work of this Section.

1.4 DELIVERY, STORAGE, AND HANDLING

- A. Comply with pertinent provisions of Section 01 66 11.

1.5 SITE CONDITIONS – Reserved.

1.6 MAINTENANCE – Reserved.

## 1.7 DEFINITION

- A. The terms sealant and caulk shall be considered synonymous whenever and wherever used in Contract Documents.

## PART 2 - PRODUCTS

### 2.1 SEALANTS

- A. Type A – Silicone Sealant:
1. Low modulus silicone sealant conforming to the latest requirements of ASTM C920, Type S, Grade NS, Class 100/50, Uses NT & M.
  2. Acceptable products:
    - a. Silpruf LM SCS2700 by GE Silicones.
    - b. Dow Corning 790 Silicone Building Sealant by Dow Corning.
    - c. Or equal.
  3. Color as selected by Engineer.
- B. Type B – Acrylic Sealant:
1. Acrylic latex plus silicone sealant conforming to the latest requirements of ASTM C834, Type OP, Grade NF single component, paintable.
  2. Acceptable products:
    - a. AC20+Silicone by Pecora Corporation.
    - b. DAP ALEX Plus Acrylic Latex Caulk Plus Silicone by DAP.
    - c. Or equal.
- C. Type C – Polyurethane Sealant (General Purpose):
1. Polyurethane sealant conforming to the latest requirements of ASTM C920, Type S, Grade NS, Class 25, Uses NT, M, A, G and O.
  2. Acceptable products:
    - a. DynaTrol I-XL by Pecora Corporation.
    - b. Sikaflex-1a by Sika Concrete Restoration Systems.
    - c. Sonolastic NP1 by Degussa Construction Chemicals.
    - d. Or equal.
- D. Type D – Polyurethane Sealant (Continuous Water Immersion):
1. Polyurethane sealant approved by manufacturer for continuous water immersion conforming to latest requirements of ASTM C920, Type S, Grade P or NS, Class 25, Uses I, M and A.
  2. Acceptable products:
    - a. Sikaflex-1a by Sika Concrete Restoration Systems.
    - b. Sikaflex-1 CSL by Sika Concrete Restoration Systems.
    - c. Or equal.
- E. Primer: Non-staining type as recommended by sealant manufacturer.

- F. Joint Backing: Flexible, compressible, closed cell polyethylene compatible with sealant.
- G. Bond Breaker: Pressure sensitive tape as recommended by sealant manufacturer.
- H. Joint cleaner: Non-corrosive and non-staining type as recommend by sealant manufacturer and compatible with joint forming material.

## PART 3 - EXECUTION

### 3.1 EXAMINATION

- A. Verify substrate surfaces and joint openings are ready to receive work.
- B. Verify that joint backing and release tapes are compatible with sealant.

### 3.2 INSTALLATION

- A. Remove loose materials and foreign matter which might impair adhesion of sealant.
- B. Clean and prime joints in accordance with sealant manufacturer's instructions.
- C. Protect elements surrounding the work from damage or disfigurement.
- D. Install in accordance with sealant manufacturer's instructions.
- E. Measure joint dimensions and size joint backers to achieve width to depth ratios, neck dimension, and surface bond area as recommended by sealant manufacturer.
- F. Install bond breaker where joint backing is not used.
- G. Install sealant free from air pockets, foreign embedded matter, ridges and sags.
- H. Tool joints.

### 3.3 CLEANING

- A. Clean adjacent soiled surfaces in accordance with sealant manufacturer's instructions.

### 3.4 SCHEDULE

- A. Contracting joints in concrete: Type C.

- B. Exposed joints between precast concrete roof deck units and precast concrete roof deck units and adjacent work: Type B.
- C. Interior and exterior joints between precast concrete roof deck units and adjacent work: Type A.
- D. Control joints in masonry, and between masonry and adjacent work: Type A, color as selected by Owner.
- E. Joints between interior and exterior frames of doors, windows, wall panels and other device set in masonry: Type A, color as selected by Owner.
- F. Exterior joints for which no other sealant type is indicated: Type C, color as selected by Owner.
- G. Interior joints for which no other sealant type is indicated: Type B, color as selected by Owner.
- H. Water immersion joints for which no other sealant type is indicated: Type D.

END OF SECTION

## SECTION 08 11 19.26

## FIBERGLASS REINFORCED PLASTIC DOORS, FRAMES, AND HARDWARE

## PART 1 - GENERAL

## 1.1 SUMMARY

- A. Provide fiberglass reinforced plastic doors, frames, and hardware where shown on the Drawings, as specified herein, and as needed for a complete and proper installation.
- B. References:
  - 1. Reserved.

## 1.2 SUBMITTALS

- A. Shop Drawing Submittals:
  - 1. Manufacturer's specifications, product literature, fabrication descriptions, installation instructions, and other data needed to prove compliance with the specified requirements.
  - 2. Frames: Frame type, frame configuration, location of cutouts for hardware, reinforcement, finish, details of openings, and details of construction, installation, and anchorage types and spacing.
  - 3. Doors: Elevations of door designs, and internal reinforcement.
  - 4. Hardware: Manufacturer's literature and cut sheets to show materials of construction and relevant information to meet specification intent.
- B. Operation and Maintenance Manuals:
  - 1. Submit manufacturer's maintenance and cleaning instructions for doors, including maintenance and operating instructions for hardware.
- C. Certificates and Guarantees – None Required.
- D. Lubricants – None Required.
- E. Spare Parts – None Required.
- F. Comply with pertinent provisions of Section 01 33 01.

## 1.3 QUALITY ASSURANCE

- A. Provide fiberglass work manufactured by a single firm specializing in the production of this type of work, including:
  - 1. Continuously engaged in manufacturing of doors of similar type to that specified, with a minimum of 25 years successful experience.
  - 2. Door and frame components from same manufacturer.
  - 3. Evidence of a compliant documented quality management system.

#### 1.4 DELIVERY, STORAGE, AND HANDLING

- A. Comply with pertinent provisions of Section 01 66 11.

#### 1.5 SITE CONDITIONS – Reserved.

#### 1.6 MAINTENANCE – Reserved.

#### 1.7 REGULATORY REQUIREMENTS

- A. General: Provide door assemblies that have been designed and fabricated to comply with specified performance requirements, as demonstrated by testing manufacturer's corresponding standard systems.
- B. Air Infiltration: For a single door 3'-0" x 7'-0", test specimen shall be tested in accordance with ASTM E 283 at pressure differential of 6.27 psf. Door shall not exceed 0.58 cfm/ft<sup>2</sup>.
- C. Water Resistance: For a single door 3'-0" x 7'-0", test specimen shall be tested in accordance with ASTM E 331 at pressure differential of 7.50 psf. Door shall not have water leakage.
- D. Indoor air quality testing per ASTM D 6670-01: GREENGUARD Environmental Institute Certified including GREENGUARD for Children and Schools Certification.
- E. Swinging Door Cycle Test, Doors and Frames, ANSI A250.4: Minimum of 25,000,000 cycles.
- F. Cycle Slam Test Method, NWWDA T.M. 7-90: Minimum 5,000,000 Cycles.
- G. Swinging Security Door Assembly, Doors and Frames, ASTM F 476: Grade 40.
- H. Salt Spray, Exterior Doors and Frames, ASTM B 117: Minimum of 500 hours.
- I. Sound Transmission, Exterior Doors, STC, ASTM E 90: Minimum of 25.
- J. Thermal Transmission, Exterior Doors, U-Value, AAMA 1503-98: Minimum of 55 CRF value.
- K. Surface Burning Characteristics, FRP Doors and Panels, ASTM E 84:
  - 1. Flame Spread: Maximum of 200, Class C.
  - 2. Smoke Developed: Maximum of 450, Class C.
- L. Surface Burning Characteristics, Class A Option On Interior Faces of FRP Exterior Panels and Both Faces of FRP Interior Panels, ASTM E 84:
  - 1. Flame Spread: Maximum of 25.
  - 2. Smoke Developed: Maximum of 450.

- M. Impact Strength, FRP Doors and Panels, Nominal Value, ASTM D 256: 14.0 foot-pounds per inch of notch.
- N. Tensile Strength, FRP Doors and Panels, Nominal Value, ASTM D 638: 13,000 psi.
- O. Flexural Strength, FRP Doors and Panels, Nominal Value, ASTM D 790: 21,000 psi.
- P. Water Absorption, FRP Doors and Panels, Nominal Value, ASTM D 570: 0.20 percent after 24 hours.
- Q. Indentation Hardness, FRP Doors and Panels, Nominal Value, ASTM D 2583: 55.
- R. Gardner Impact Strength, FRP Doors and Panels, Nominal Value, ASTM D 5420: 120 in-lb.
- S. Abrasion Resistance, Face Sheet, Taber Abrasion Test, 25 Cycles at 1,000 Gram Weight with CS-17 Wheel: Maximum of 0.029 average weight loss percentage.
- T. Stain Resistance, ASTM D 1308: Face sheet unaffected after exposure to red cabbage, tea, and tomato acid. Stain removed easily with mild abrasive or FRP cleaner when exposed to crayon and crankcase oil.
- U. Chemical Resistance, ASTM D 543. Excellent rating.
  - 1. Acetic acid, Concentrated.
  - 2. Ammonium Hydroxide, Concentrated.
  - 3. Citric Acid, 10%.
  - 4. Formaldehyde.
  - 5. Hydrochloric Acid, 10%
  - 6. Sodium hypochlorite, 4 to 6 percent solution.
- V. Compressive Strength, Foam Core, Nominal Value, ASTM D 1621: 79.9 psi.
- W. Compressive Modulus, Foam Core, Nominal Value, ASTM D 1621: 370 psi.
- X. Tensile Adhesion, Foam Core, Nominal Value, ASTM D 1623: 45.3 psi.
- Y. Thermal and Humid Aging, Foam Core, Nominal Value, 158 Degrees F and 100 Percent Humidity for 14 Days, ASTM D 2126: Minus 5.14 percent volume change.

## PART 2 - PRODUCTS

### 2.1 ACCEPTABLE MANUFACTURERS

- A. Special-Lite, Inc., PO Box 6, Decatur, Michigan 49045. Toll Free (800) 821-6531. Phone (269) 423-7068. Fax (800) 423-7610. Web Site [www.special-lite.com](http://www.special-lite.com). E-Mail [info@special-lite.com](mailto:info@special-lite.com).

- B. Or equal:
  - 1. Substitution of another manufacturer will not be considered unless the proposed substitute manufacturer's door has successfully demonstrated door approval and design features of the door from Owner.

## 2.2 FRP DOORS

- A. Model: SL-17 Flush Doors with SpecLite3 fiberglass reinforced polyester (FRP) face sheets.
- B. Door Opening Size as Indicated within Door Schedule in Paragraph 2.7 of these specifications.
- C. Construction:
  - 1. Door Thickness: 1-3/4 inches.
  - 2. Stiles and Rails: Aluminum extrusions made from prime-equivalent billet that is produced from 100% reprocessed 6063-T6 alloy recovered from industrial processes, minimum of 2-5/16-inch depth.
  - 3. Corners: Mitered.
  - 4. Provide joinery of 3/8-inch diameter full-width tie rods through extruded splines top and bottom integral to standard tubular shaped stiles and rails reinforced to accept hardware as specified.
  - 5. Securing Internal Door Extrusions: 3/16-inch angle blocks and locking hex nuts for joinery. Welds, glue, or other methods are not acceptable.
  - 6. Furnish extruded stiles and rails with integral reglets to accept face sheets. Lock face sheets into place to permit flush appearance.
  - 7. Rail caps or other face sheet capture methods are not acceptable.
  - 8. Extrude top and bottom rail legs for interlocking continuous weather bar.
  - 9. Meeting Stiles: Pile brush weatherseals. Extrude meeting stile to include integral pocket to accept pile brush weatherseals.
  - 10. Bottom of Door: Install bottom weather bar with nylon brush weatherstripping into extruded interlocking edge of bottom rail.
  - 11. Glue: Use of glue to bond sheet to core or extrusions is not acceptable.
- D. Face Sheet:
  - 1. Material: SpecLite3 FRP, 0.120-inch thickness, finish color throughout.
  - 2. Protective coating: Abuse-resistant engineered surface. Provide FRP with SpecLite3 protective coating, or equal.
  - 3. Texture: Pebble.
  - 4. Color: Dark Bronze.
  - 5. Adhesion: The use of glue to bond face sheet to foam core is prohibited.
- E. Core:
  - 1. Material: Poured-in-place polyurethane foam.
  - 2. Density: Minimum of 5 pounds per cubic foot.
  - 3. R-Value: Minimum of 9.
- F. Cutouts:
  - 1. Manufacture doors with cutouts for required vision lites, louvers, and panels.



2. Factory install vision lites, louvers, and panels.

G. Hardware:

1. Premachine doors in accordance with templates from specified hardware manufacturers and hardware schedule.
2. Factory install hardware.

## 2.3 DOOR AND FRAME MATERIALS

A. Aluminum Members:

1. Aluminum extrusions made from prime-equivalent billet that is produced from 100% reprocessed 6063-T6 alloy recovered from industrial processes: ASTM B 221.
2. Sheet and Plate: ASTM B 209.
3. Alloy and Temper: As required by manufacturer for strength, corrosion resistance, application of required finish, and control of color.

B. Components: Door and frame components from same manufacturer.

C. Fasteners:

1. Material: Aluminum, 18-8 stainless steel, or other noncorrosive metal.
2. Compatibility: Compatible with items to be fastened.
3. Exposed Fasteners: Screws with finish matching items to be fastened.

## 2.4 FABRICATION

A. Sizes and Profiles: Required sizes for door and frame units, and profile requirements shall be as indicated in the table at the end of these specifications.

B. Coordination of Fabrication: Field measure before fabrication and show recorded measurements on shop drawings.

C. Assembly:

1. Complete cutting, fitting, forming, drilling, and grinding of metal before assembly.
2. Remove burrs from cut edges.

D. Welding: Welding of doors or frames is not acceptable.

E. Fit:

1. Maintain continuity of line and accurate relation of planes and angles.
2. Secure attachments and support at mechanical joints with hairline fit at contacting members.

## 2.5 HARDWARE

A. Pre-machine doors in accordance with templates from noted hardware manufacturers and schedule noted below.

B. Interior Doors to Heated Valve Room (Door 101):

1. 2 SL17 Doors.
2. 260 Framing.
3. 2 Hinges SL11hd.
4. 2 Flush Bolts 1555.
5. 1 Closer - Dorma 8916DST.
6. 1 Overhead Stop 9010 –Inactive Door.
7. 2 Kickplates 8".
8. 1 threshold 428 – Field Verify Width.
9. 2 Integral Sweeps SL301.
10. 1 Astragal By Door Mfg.

C. Exterior Door (102):

1. 1 SL17 Doors.
2. 260 Framing.
3. 1 Hinge SL11hd.
4. 1 Power Transfer Pt1000.
5. 1 Electric Lockset Dorma C880EU LRC.
6. 1 Exit Device 9300 X Prt03 X Cyl.
7. 1 Dorma 8916 Ds.
8. 1 Kickplate 8".
9. 1threshold 428 – Field Verify Width.
10. 1 Integral Sweeps SL301.
11. 1 Door Position Switch MC4.
12. 1 Latch Guard.
13. New Card Reader/Security.

D. Bathroom Door (103):

1. 1 SL17 Door.
2. 260 Framing.
3. 1 Hinge SL11HD.
4. 1 Dorma C880 LRC.
5. 1 Dorma 8916 DS.
6. 1 Kickplate 8".
7. 1threshold 428 – Field Verify Width.
8. 1 Integral Sweeps SL301.

## 2.6 ALUMINUM FINISHES

A. Anodized Finish: Class I finish, 0.7 mils thick.

1. Dark Bronze, AA-M10C12C22A44, Class I, 0.7 mils thick.

2.7 DOOR SCHEDULE

A. Provide doors as noted below.

Door Number	Door Sizes	Nominal M.O.	Swing	Frame Size
101	38" by 84"	80" by 88"	RH (active), LH (inactive)	2 x 3.5
102	36" by 84"	40" by 88"	LHR	2 x 3.5
103	36" by 84"	40" by 88"	RH	2 x 3.5

PART 3 - EXECUTION

3.1 SURFACE CONDITIONS

A. Examine the areas, substrates, and conditions under which work of this Section will be performed. Correct conditions detrimental to timely and proper completion of the Work.

3.2 INSTALLATION

A. General: Install FRP doors, frames and accessories in accordance with final shop drawings, as herein specified, and in accordance with manufacturer's written instructions.

- B. Placing frames:
1. When practical, place frames prior to construction of enclosing walls and ceilings.
  2. Set frames accurately into position, plumbed, aligned, and braced securely until permanent anchors are set.
  3. Place anchors at hinge locations and extend at least 8 inches into the masonry.
  4. Paint inside of frames with bituminous coating and fill the space between the frames and the wall with grout.
  5. After wall construction is completed, remove temporary braces and spreaders, leaving surfaces smooth and undamaged.
    - a. To avoid damaging finish, do not drill frame for brace supports.

- C. Door Installation:
1. Fit FRP doors accurately in frames, within adequate clearances.

3.3 PROTECT, ADJUST AND CLEAN

A. Protect fiberglass reinforced plastic work and finish against harmful substances and construction activities.

- B. Final adjustments:
1. Check and readjust all operable components to ensure they are properly installed and that they function smooth and freely.
  2. Leave work in complete and proper operating condition.
  3. Remove defective work and replace with work complying with the specified requirements.
- C. Remove dirt and excess sealant from exposed surfaces.
1. Follow the manufacturer's recommended cleaning techniques and procedures for cleaning all surfaces.
  2. Use only cleaning products that will not scratch or damage the surfaces, and are recommended by the manufacturer.
  3. Repair or replace materials damaged resulting from the use of other cleaning materials.

END OF SECTION

SECTION 08 36 13

SECTIONAL DOORS

PART 1 - GENERAL

1.1 SUMMARY

- A. Provide sectional doors as shown on the Drawings, as specified herein, and as needed for a complete and proper installation.
- B. Related work:
  - 1. Documents affecting work under this Section include, but are not necessarily limited to, General Conditions, Supplementary Conditions, and Division 01 - General Requirements of these Specifications.
- C. References:
  - 1. Reserved.

1.2 SUBMITTALS

- A. Shop Drawing Submittals:
  - 1. Manufacturer's specifications and other data needed to prove compliance with the specified requirements.
  - 2. Frame type, elevations of door designs, details of openings, and details of construction, installation, and anchorage.
  - 3. Manufacturer's recommended installation procedures.
- B. Operation and Maintenance Manuals – None Required.
- C. Certificates and Guarantees – None Required.
- D. Lubricants – None Required.
- E. Spare Parts – None Required.
- F. Comply with pertinent provisions of Section 01 33 01.

1.3 QUALITY ASSURANCE – Reserved.

1.4 DELIVERY, STORAGE, AND HANDLING

- A. Comply with pertinent provisions of Section 01 66 11.

1.5 SITE CONDITIONS – Reserved.

1.6 MAINTENANCE – Reserved.

## PART 2 - PRODUCTS

### 2.1 SECTIONAL OVERHEAD DOORS

- A. Provide doors of the type, dimensions and arrangements shown on the Drawings and as specified herein.
- B. Door features:
  - 1. Door panels:
    - a. Insulated, sectionalized steel construction, 1-5/8-inch thick.
    - b. Flush exterior face panels of 16-gauge galvanized steel.
    - c. Polystyrene core insulation with U-factor of 0.07.
    - d. Interior cover of 26-gauge galvanized steel.
    - e. Center and end stiles of 16-gauge galvanized steel.
    - f. Reinforce door to withstand 20-pound per square foot wind load when closed and limit deflection to less than 1/120 span width when fully open.
    - g. Weathertight section joints.
  - 2. Tracks:
    - a. Galvanized steel construction with reinforcing.
    - b. Rigidly secured to continuous bracket or angle mounts.
    - c. Design tracks for full vertical lift as shown on the Drawings.
    - d. Track supports as required for mounting.
  - 3. Hardware and rollers:
    - a. Galvanized steel construction.
    - b. End roller hinges and adjustable top roller brackets.
    - c. Twin full floating ball bearing rollers with adjustable cam plates at each section side.
  - 4. Torsion springs and cables:
    - a. Helical-wound high-tensile strength springs.
    - b. Counterbalancing springs mounted on cross header shaft and custom designed for each door.
    - c. Galvanized steel aircraft grade lift cables.
    - d. Minimum service life of 10,000 operating cycles.
  - 5. Weatherstripping:
    - a. Vinyl seals around door opening perimeter.
    - b. Vinyl "U" type bottom astragal attached to door edge.
  - 6. Acceptable door manufacturers and model:
    - a. Overhead Door Series 591 (Represented by Overhead Door Company of Madison; 608-271-4288).
    - b. Or equal.
- C. Manual operators:
  - 1. Provide adjustable spring-loaded automatic latching with inside and outside latch handles and a tumbler cylinder lock keyed from outside with inside thumb-turn.
- D. Electric operators:
  - 1. Electric powered draw bar trolley operator.

2. Totally enclosed drive motor, 1/3 horse-power, 120 volts, single phase, reversing type with thermal overload protection.
  3. Belt and chain drive reduction system.
  4. Driven limit switches for open and close positions.
  5. Adjustable friction clutch and solenoid brake.
  6. Trolley track full chain driven carriage.
  7. Quick release door arm.
  8. Pneumatic bottom door edge with take-up reel.
    - a. Reverse door on contact with obstruction in its closing path.
  9. Auxiliary chain hoist with disengaging clutch and release chain.
    - a. Design for maximum 40-pound pull force to operate door.
  10. NEMA 4 rated, three-button, momentary contact, open-close-stop pushbutton control station mounted as shown on the Drawings.
  11. Dual Photo Eye Sensors; Lift Master CPS OPEN4 or equal.
  12. Acceptable operator manufacturers and model:
    - a. Lift Master - J50L5 (Represented by Overhead Door Company of Madison; 608-271-4288).
    - b. Or equal.
- E. Pre-clean, phosphate treat and shop paint all steel surfaces with one baked-on coat of primer compatible with finish paint to be applied at the job site under Section 09 90 00 of these Specifications.

## PART 3 - EXECUTION

### 3.1 INSTALLATION

- A. Install in accordance with manufacturer's recommendations.

END OF SECTION

SECTION 08 71 00  
DOOR HARDWARE

PART 1 - GENERAL

1.1 SUMMARY

- A. Work included:
  - 1. Furnish finish hardware required to complete the Work as shown on the Drawings and as specified herein.
  - 2. Furnish trim attachments and fastenings, specified or otherwise required, for proper and complete installation.
  
- B. Related work:
  - 1. Documents affecting work of this Section include, but are not necessarily limited to, General Conditions, Supplementary Conditions, and Division 01 - General Requirements of these Specifications.
  - 2. Requirements of Section 08 11 19.26 will govern over minimum requirements of this Section.
  
- C. References:
  - 1. Reserved.
  
- D. Americans With Disabilities Act:
  - 1. Furnish finish hardware complying with the requirements of the Americans With Disabilities Act.

1.2 SUBMITTALS

- A. Shop Drawing Submittals:
  - 1. Materials list of items proposed to be provided under this Section. Approval of this list by the Engineer will not relieve the Contractor of the responsibility to provide all finish hardware items required for the Work even though such required items may not have been shown on the approved list.
  - 2. Manufacturer's specifications and other data needed to prove compliance with the specified requirements.
  - 3. Manufacturer's recommended installation procedures.
  
- B. Operation and Maintenance Manuals – None Required.
  
- C. Certificates and Guarantees – None Required.
  
- D. Lubricants – None Required.
  
- E. Spare Parts – None Required.



- F. Templates: In a timely manner to assure orderly progress of the Work, deliver templates or physical samples of the approved finish hardware items to pertinent manufacturers of interfacing items such as doors and frames.
- G. Comply with pertinent provisions of Section 01 33 01.

### 1.3 QUALITY ASSURANCE

- A. Use adequate numbers of skilled workmen who are thoroughly trained and experienced in the necessary crafts and who are completely familiar with the specified requirements and the methods needed for proper performance of the work of this Section.

### 1.4 DELIVERY, STORAGE, AND HANDLING

- A. Comply with pertinent provisions of Section 01 66 11.
- B. Individually package each unit of finish hardware, complete with proper fastenings and appurtenances, clearly marked on the outside to indicate contents and specific locations in the Work.

### 1.5 SITE CONDITIONS – Reserved.

### 1.6 MAINTENANCE – Reserved.

## PART 2 - PRODUCTS

### 2.1 FASTENERS

- A. Furnish necessary screws, bolts, and other fasteners of suitable size and type to anchor the hardware in position.
- B. Where necessary, furnish fasteners with toggle bolts, expansion shields, hex bolts, and other anchors approved by the Engineer according to the recommendations of the hardware manufacturer.
- C. Provide fasteners which harmonize with the hardware as to finish and material.

### 2.2 HINGES

- A. Provide three 4½-inch x 4½-inch full mortise template type heavy-weight stainless steel hinges for each swing door.
  - 1. Acceptable products:
    - a. Hager No. BB1199.
    - b. Stanley No. FBB199.
    - c. Or equal.

## 2.3 LOCKSETS

- A. Provide heavy duty, cylindrical type locksets with matching lever style and universal jamb strike.
  - 1. Comply with Federal Specification No. FF-H-106C, Government Series 161 and ANSI A156.2 Series 4000 Grade 1 and ANSI A117.1.
- B. Exterior doors:
  - 1. Provide Federal Specification No. 161A, ANSI F109 entrance door lockset with electronic door access swipe, provided by SCADA subcontractor.
  - 2. Acceptable products:
    - a. Yale Series No. 5407LN (or equal).
    - b. Corbin/Russwin Series No. CL 3551 (or equal).
- C. Interior passage doors:
  - 1. Provide Federal Specification No. 161N, ANSI F75 passage door latch set.
  - 2. Acceptable products:
    - a. Yale Series No. 5401LN.
    - b. Corbin/Russwin Series No. CL 3510.
    - c. Or equal.
- D. Bathroom doors:
  - 1. Provide Federal Specification 161L-ANSI F76, Grade 1 door lockset.
  - 2. Acceptable products:
    - a. Yale Series No. 5402LN.
    - b. Corbin/Russwin No. CL 3520.
    - c. Or equal.

## 2.4 KEYING

- A. Provide three keys for each lock.
- B. Key all locks alike and match existing key systems wherever practical, except:
  - 1. All keys to match Madison Water Utility standards.
  - 2. Utilize \$500 allowance to provide lockset requirements above these minimum requirements.

## 2.5 CLOSERS

- A. Provide heavy duty hydraulically controlled full rack and pinion type closer for each single swing door and active leaf of each double swing door. Provide closer with 90-140 degree hold-open arm.
- B. Comply with ANSI A156.4, Grade 1.
- C. Acceptable products:
  - 1. Yale Series No.51BF.
  - 2. Corbin Russwin Series No. DC 6000.
  - 3. Or equal.

## 2.6 ASTRAGAL

- A. For the inactive leaf of double doors, provide an overlapping type astragal with vinyl seal and universal strike adaptor.

## 2.7 HOLDER

- A. For the inactive leaf of double doors, provide Underwriters approved surface mounted solid bar slide bolts with top universal keeper and bottom recessed keeper.

## 2.8 WEATHER-STRIPPING

- A. Provide weather-stripping to resist infiltration of air and water at all exterior doors.
- B. Provide weather-stripping to resist infiltration of air and water at interior access doors for the following types of rooms:
  - 1. Chemical feed and storage rooms.
  - 2. Unheated storage rooms.
  - 3. Motor vehicle garages.
  - 4. Motor vehicle loading rooms.
  - 5. Engine-generator rooms.
- C. Provide ½-inch thick by 6-inch wide heavy duty fluted top aluminum saddle type threshold at doors to be weather-stripped.
  - 1. Acceptable product: Pemko No. 172A, or equal.
- D. At head and jambs of door frames, provide continuous heavy duty extruded aluminum interlocking door gasketing with silicone seal insert weather-stripping.
  - 1. Acceptable product: Pemko No. 303AS, or equal.
- E. At bottom of doors, provide a continuous heavy duty extruded aluminum channel with integral drip at the outside face of the door and flexible vinyl insert weather-stripping.
  - 1. Acceptable product: Pemko No. 216AV, or equal.
- F. At top of doors, provide a continuous heavy duty extruded aluminum interlocking weather-stripping unit with integral drip cap at the outside face of the door and built in rubber seal.
  - 1. Acceptable product: Pemko No. 68AR-347A, or equal.

## 2.9 DOOR STOPS

- A. For interior swing type doors, provide a dome type floor mounted door stop.
  - 1. Comply with Federal Specification Type 1300-A.
  - 2. Acceptable products:
    - a. Ives Series No. FS438.
    - b. Baldwin Series No. 4010.
    - c. Or equal.

- B. For exterior swing type doors, provide a pedestal type floor mounted door stop.
  - 1. Comply with Federal Specification Type 1328-E.
  - 2. Acceptable products:
    - a. Ives Series No. FS444.
    - b. Baldwin Series No. 4510.
    - c. Or equal.

2.10 SURFACE FINISH

- A. Provide standard US-26D chrome plated finish for locksets, closers, door stops, and other similar hardware.

PART 3 - EXECUTION

3.1 INSTALLATION

- A. Install hardware in accordance with manufacturer's recommendations.

3.2 FINAL ADJUSTMENTS

- A. Check and readjust operating finish hardware items.
- B. Leave work in complete and proper operating condition.
- C. Remove defective work and replace with work complying with the specified requirements.

END OF SECTION

## SECTION 08 91 00

## LOUVERS

## PART 1 - GENERAL

## 1.1 SUMMARY

- A. Provide louvers, screens, and associated dampers as shown on the Drawings, as specified herein, and as needed for a complete and proper installation.
- B. Related work:
  - 1. Documents affecting work of this Section include, but are not necessarily limited to, General Conditions, Supplementary Conditions, and Division 01 - General Requirements of these Specifications.
- C. This Section includes the following:
  - 1. Fixed, extruded-aluminum louvers.
- D. Related Sections:
  - 1. Refer to Section 23 00 00, HEATING, VENTILATING, AND AIR CONDITIONING (HVAC) for ductwork, motorized dampers, and gravity dampers associated with louvers.
- E. References:
  - 1. Reserved.

## 1.2 SUBMITTALS

- A. Shop Drawing Submittals:
  - 1. Materials list of items proposed to be provided under this Section.
  - 2. Manufacturer's specifications and other data needed to prove compliance with the specified requirements.
  - 3. Louver performance data, include printed catalog pages or computer selection results showing airflow pressure loss and water penetration based on tests in accordance with AMCA 500 standards.
    - a. For louvers specified to bear AMCA seal, include printed pages showing specified models with appropriate AMCA Certified Ratings Seals.
    - b. Indicate free area of each louver provided.
  - 4. Fabrication, installation, anchorage, and interface of the work of this Section with the work of adjacent trades.
- B. Operation and Maintenance Manuals – None Required.
- C. Certificates and Guarantees – None Required.
- D. Lubricants – None Required.

## LOUVERS

08 91 00-1 (150826.40)

- E. Spare Parts – None Required.
- F. Comply with pertinent provisions of Section 01 33 01.

### 1.3 QUALITY ASSURANCE

- A. Source Limitations: Obtain louvers through one source from a single manufacturer where indicated to be of same type, design, or factory-applied color finish.

### 1.4 DELIVERY, STORAGE, AND HANDLING

- A. Comply with pertinent provisions of Section 01 66 11.

### 1.5 SITE CONDITIONS – Reserved.

### 1.6 MAINTENANCE – Reserved.

## PART 2 - PRODUCTS

### 2.1 FIXED, EXTRUDED ALUMINUM LOUVERS

- A. General: Unless indicated otherwise, provide stationary type fixed aluminum louvers with drainable heads and drainable blades in 4" deep frames.
  - 1. Blades shall be positioned at 37 degree and 45 degree angles; approximately on 4" centers.
  - 2. Incorporate an integral drain gutter into the head and each stationary blade to drain water drain to ends of each blade and head.
  - 3. Incorporate an integral downspout into each jamb to drain water from the end of each blade and head, down the downspouts, and out at the louver sill; rather than cascading from blade to blade.
  - 4. Incorporate integral aluminum extended sill at bottom of louver.
- B. Construction: Welded construction with louver frames and blades fabricated of extruded aluminum, alloy 6063-T5, minimum 0.08-inch thickness.
- C. Screens: Provide framed, removable, rear-mounted bird screens constructed of aluminum wire mesh with no less than 0.063-inch wire diameter and ½-inch mesh openings.
- D. Wind Loading: Design factory-assembled louver sections to withstand wind loadings of 25 pounds per square foot.
- E. Finish: Provide clear anodized or color anodized finish as selected by Owner.
  - 1. Clear Anodized Finish: Minimum 0.7 mil thick clear anodized finish in accordance with AA-M10C22A41.
  - 2. Color Anodized Finish: Minimum 0.7 mil thick color anodized finish in accordance with AA-M10C22A44 in color selected by the Owner.

- F. AMCA Seal: Mark units with AMCA Certified Ratings Seal.
- G. Acceptable products: Subject to compliance with requirements, provide one of the following:
  1. Greenheck Model ESD-403.
  2. Ruskin Model ELF-375DX.
  3. No exceptions.

## PART 3 - EXECUTION

### 3.1 EXAMINATION

- A. Examine substrates and openings, with Installer present, for compliance with requirements for installation tolerances and other conditions affecting performance.
  1. Proceed with installation only after unsatisfactory conditions have been corrected.

### 3.2 INSTALLATION

- A. Install the work of this Section in accordance with the approved Shop Drawings and the recommendations of the manufacturers as approved by the Engineer.
- B. Locate and place louvers level, plumb, and at indicated alignment with adjacent work.
- C. Anchor all components firmly into position using concealed anchorages where possible. Provide synthetic washers fitted to screws where required to protect metal surfaces and to make a weather-tight connection.
- D. Provide perimeter reveals and openings of uniform width for sealants and joint fillers.
- E. Repair finishes damaged by cutting, welding, soldering, and grinding. Restore finishes so no evidence remains of corrective work. Return items that cannot be refinished in the field to the factory, make required alterations, and refinish entire unit or provide new units.
- F. Protect galvanized and nonferrous-metal surfaces from corrosion or galvanic action by applying a heavy coating of bituminous paint on surfaces that will be in contact with concrete, masonry, or dissimilar metals.
- G. Wall Opening Sleeves: In walls other than fiberglass construction, provide aluminum sheet metal sleeves in wall openings to form an air-tight connection between the exterior and interior wall openings; comply with requirements of Section 23 00 00, HEATING, VENTILATING, AND AIR CONDITIONING (HVAC).
  1. Set aluminum in asphaltic mastic where sleeves are installed in concrete or masonry wall openings.
  2. Terminate sleeves flush with outside louver surface.
  3. Terminate sleeves with 1.25-inch wide extruded aluminum border with mitered corners at inside wall surface.

- 4. Install louvers in wall openings only after aluminum sleeves have been installed.
- H. Support louver frames, mullions, and section joints adequately from the building structure to withstand wind loadings of 25 pounds per square foot.
- I. Seal exterior louver perimeter to wall opening according to manufacturer's installation instructions.

### 3.3 CLEANING

- A. Clean exposed surfaces of louvers that are not protected by temporary covering, to remove fingerprints and soil during construction period. Do not let soil accumulate until final cleaning.
- B. Before final inspection, clean exposed surfaces with water and a mild soap or detergent not harmful to finishes. Thoroughly rinse surfaces and dry.
- C. Restore louvers damaged during installation and construction so no evidence remains of corrective work. If results of restoration are unsuccessful, as determined by Owner, remove damaged units and replace with new units.
- D. Touch up minor abrasions in finishes with air-dried coating that matches color and gloss of, and is compatible with, factory-applied finish coating.

END OF SECTION



SECTION 09 90 00  
PAINTING AND COATING

PART 1 - GENERAL

1.1 SUMMARY

- A. Paint and finish exposed surfaces using the combination of materials listed on Painting Schedule in Part 3 of this Section, as specified herein, and as needed for a complete and proper installation.
- B. Related work:
1. Documents affecting work of this Section include, but are not necessarily limited to, General Conditions, Supplementary Conditions, and Division 01 - General Requirements of these Specifications.
  2. Priming or priming and finishing of certain surfaces may be specified to be factory-performed or installer-performed under pertinent other Sections.
  3. See specification Section 33 16 19.33, Concrete/Steel Composite Water Storage Tank for specific information regarding painting requirements for the water storage tank, which may exceed the requirements of this section.
- C. References:
1. Reserved.
- D. Work not included:
1. Metal surfaces of submerged galvanized metal more than 12 inches below water surface, anodized aluminum, stainless steel, chromium plate, and similar finished materials will not require painting under this Section except as may be so specified in other Sections of these Specifications.
  2. Do not paint moving parts of operating units; mechanical or electrical parts such as valve operators; linkages; sensing devices; and motor shafts, unless otherwise specified.
  3. Do not paint over required labels or equipment identification, performance rating, name, or nomenclature plates.
  4. Do not paint explosion-proof light fixtures, junction boxes, fittings or accessories.
- E. Definitions:
1. "Paint" as used herein, means coating systems materials including primers, emulsions, epoxy, enamels, sealers, fillers, and other applied materials whether used as prime, intermediate, or finish coats.

## 1.2 SUBMITTALS

- A. Shop Drawing Submittals:
  - 1. Materials list of items proposed to be provided under this Section.
  - 2. Manufacturer's specifications and other data needed to prove compliance with the specified requirements.
  - 3. Color charts for selection of colors by the Owner.
- B. Operation and Maintenance Manuals – None Required.
- C. Certificates and Guarantees:
  - 1. Contractor Qualifications - Provide certification of previous experience and equipment necessary to apply/install the specified painting and coating systems.
- D. Lubricants – None Required.
- E. Spare Parts – None Required.
- F. Comply with pertinent provisions of Section 01 33 01.

## 1.3 QUALITY ASSURANCE

- A. Use adequate numbers of skilled workmen who are thoroughly trained and experienced in the necessary crafts and who are completely familiar with the specified requirements and the methods needed for proper performance of the work of this Section.
- B. Paint coordination:
  - 1. Within 35 calendar days after the Contractor has received the Engineer's Notice to Proceed, arrange a conference with a technical representative of the paint manufacturer, the Engineer, the Contractor, and the Owner to:
    - a. review the paint systems to be used;
    - b. select colors;
    - c. review painting procedures; and
    - d. establish painting schedule.
  - 2. Notify the equipment manufacturers and miscellaneous metals fabricators of the correct shop primer to be used to assure compatibility of the total coating system.
  - 3. Review other Sections of these Specifications as required, verifying the prime coats to be used and assuring compatibility of the total coating system.
  - 4. Provide barrier coats over non-compatible primers, or remove the primer and reprime as required.
  - 5. Notify the Engineer in writing of anticipated problems in using the specified coating systems over prime-coatings supplied under other Sections.

#### 1.4 DELIVERY, STORAGE, AND HANDLING

- A. Comply with pertinent provisions of Section 01 66 11.
  - 1. Store materials in a safe, ventilated location.
  - 2. Remove oily rags, waste, etc. every day and do not allow to accumulate under any circumstances.
  - 3. Take precautions to prevent spontaneous combustion.

#### 1.5 SITE CONDITIONS

- A. Do not apply paints when the temperature of surfaces to be painted and the surrounding air temperatures are below 50 degrees F, unless otherwise permitted by the manufacturers' printed instructions as approved by the Engineer.
- B. Weather conditions:
  - 1. Do not apply paint in snow, rain, fog, or mist; or when the relative humidity exceeds 85 percent; or to damp or wet surfaces, unless otherwise permitted by the manufacturers' printed instructions as approved by the Engineer.
  - 2. Applications may be continued during inclement weather only within the temperature limits specified by the paint manufacturer as being suitable for use during application and drying periods.

#### 1.6 MAINTENANCE

- A. Upon completion of the work of this Section, deliver to the Owner an extra stock equaling 10 percent, but not less than one gallon, of each color, type, and gloss of paint used in the Work, tightly sealing each container, and clearly labeling with contents and location where used.

### PART 2 - PRODUCTS

#### 2.1 PAINT MATERIALS

- A. Acceptable materials:
  - 1. The Painting Schedule in Part 3 of this Section is based on products of the Tnemec Company, Inc., except where another manufacturer is named for a specific application.
  - 2. Products of other manufacturers may be submitted for review in accordance with provisions of the Contract. These products will be considered substitutions and will be reviewed in accordance with the requirements of General Conditions, Article 6.05 and Section 01 62 01. Contractor is responsible for reimbursement of the Engineer's substitute products review costs to the Owner as described in General Conditions, Article 6.05 E.
  - 3. Where products are proposed other than those specified by name and number in the Painting Schedule, provide submittal required by Article 1.2

of this Section and a new painting schedule compiled in the same format used for the Painting Schedule included in this Section.

- B. Undercoats:
  - 1. Provide undercoat paint produced by the same manufacturer as the finish coat.
  - 2. Insofar as practicable, use undercoat and finish coat material as parts of a unified system of paint finish.
- C. Provide all paints and materials supplied by one manufacturer.

## 2.2 APPLICATION EQUIPMENT

- A. For application of the approved paint, use only such equipment as is recommended for application of the particular paint by the manufacturer of the particular paint, and as approved by the Engineer.
- B. Prior to use of application equipment, verify that the proposed equipment is actually compatible with the material to be applied, and that integrity of the finish will not be jeopardized by use of the proposed equipment.

## 2.3 OTHER MATERIALS

- A. Provide other materials, not specifically described but required for a complete and proper installation, as selected by the Contractor subject to the approval of the Engineer.

# PART 3 - EXECUTION

## 3.1 SURFACE CONDITIONS

- A. Examine the areas and conditions under which work of this Section will be performed.
  - 1. Correct conditions detrimental to timely and proper completion of the Work.
  - 2. Do not proceed until unsatisfactory conditions are corrected.

## 3.2 MATERIALS PREPARATION

- A. General:
  - 1. Mix and prepare paint materials in strict accordance with the manufacturers' recommendations as approved by the Engineer.
  - 2. When materials are not in use, store in tightly covered containers.
  - 3. Maintain containers used in storage, mixing, and application of paint in a clean condition, free from foreign materials and residue.

- B. Stirring:
1. Stir materials before application, producing a mixture of uniform density.
  2. Do not stir into the material any film which may form on the surface, but remove the film and, if necessary, strain the material before using.

### 3.3 SURFACE PREPARATION

- A. General:
1. Perform preparation and cleaning procedures in strict accordance with the paint manufacturers' recommendations as approved by the Engineer.
  2. Remove removable items such as hardware, accessories, nameplates, fixtures which are in place and are not scheduled to receive paint finish; or provide surface applied protection prior to surface preparation and painting operations.
  3. Following completion of painting in each space or area, reinstall the removed items by using workmen who are skilled in the necessary trades.
  4. Clean each surface to be painted prior to applying paint or surface treatment.
  5. Schedule the cleaning and painting so that dust and other contaminants from the cleaning process will not fall onto wet newly painted surfaces and other surfaces.
- B. Preparation of wood surfaces:
1. Fill, prime and clean wood surfaces until free from dirt, oil, and other foreign substance.
  2. Smooth finished wood surfaces exposed to view, using the proper sandpaper to produce a uniformly smooth and unmarred wood surface.
- C. Preparation of metal surfaces:
1. Thoroughly clean surfaces until free from dust, dirt, black oxide, scale, rust, paint, oil, and grease in accordance with The Society for Protective Coatings (SSPC) Specifications required in Paint Schedule.
  2. On galvanized surfaces, prepare in accordance with the methods outlined in ASTM D 6386-99 Standard Practice for Preparation of Zinc (Hot Dipped Galvanized) Coated Iron and Steel Product and Hardware Surfaces for Painting.
- D. Preparation of concrete and masonry surfaces:
1. Clean concrete and masonry surfaces by the methods outlined in SSPC SP-13, Surfaces Preparation of Concrete. Use wire brushing, scraping, high pressure water cleaning, mechanical abrasion, blast tracking, or sandblasting as necessary and as required on the Paint Schedule. Vacuum clean, air blast clean or water clean to remove dirt, dust and loose material. Steam clean or detergent clean to remove oils and grease, efflorescence, stains and contaminants.
  2. Allow new concrete and masonry to cure a minimum of 28 days before paint application.
  3. Level protrusions and mortar spatter.

- E. Preparation of Ductile and Cast Iron Surfaces:
1. Solvent clean in accordance with NAPF 500-03-01 Surface Preparations Standard for Solvent Cleaning.
  2. Abrasive Blast Cleaning of Ductile and Cast Iron:
    - a. For external pipe surfaces, abrasive blast clean in accordance with NAPF 500-03-04 Surface Preparations Standards for Abrasive Blast Cleaning – External Pipe Surfaces.
    - b. For internal pipe surfaces, abrasive blast clean in accordance with NAPF 500-03-04 Surface Preparations Standards for Abrasive Blast Cleaning – Internal Pipe Surfaces.

### 3.4 PAINT APPLICATION

- A. General:
1. Touch-up shop-applied prime coats which have been damaged, and touch-up bare areas prior to start of finish coats application.
  2. Notify the Engineer or the Owner of the completion of each coat.
    - a. Do not apply additional coats until the completed coat has been inspected and approved.
    - b. Only the inspected and approved coats of paint will be considered in determining the number of coats applied.
  3. Do all necessary touching up after other mechanics have finished and leave entire work in a neat and clean condition.
  4. Do not leave paint spots on glass, hardware, floors, or other finished work.
  5. If required by the Engineer, tint by mixing a small amount of white paint of the exact same type with any or all paint used prior to the final coat so that the area covered by the application of each coat is readily discernible.
  6. Provide an approved gauge for determining the mil thickness of the paint on a surface.
- B. Drying:
1. Allow sufficient drying time between coats, modifying the period as recommended by the material manufacturer to suit adverse weather conditions.
- C. Brush applications:
1. Apply the painting materials by brush and work the brush coats onto the surface in an even film.
  2. Cloudiness, spotting, holidays, laps, brush marks, runs, sags, ropiness, and other surface imperfections will not be acceptable.
- D. Spray application:
1. Except as specifically otherwise approved by the Engineer, confine spray application to metal and similar surfaces where hand brush work would be inferior.

2. Where spray application is used, apply each coat to provide the hiding equivalent of brush coats.
  3. Do not double back with spray equipment to build up film thickness of two coats in one pass.
  4. Protect other surfaces from over spray.
- E. For completed work, match the approved texture, color, and coverage. Remove, refinish, or repaint work not in compliance with the specified requirements.

### 3.5 PAINTING SCHEDULE

		<u>Dry Film - mils</u>
A.	Steel, iron, galvanized and non-ferrous metal; tanks, pipes, conduits, electrical boxes, and equipment:	
1.	Exterior, non-immersion: System Series 1075 Endura-Shield.	
a.	Surface preparation: SSPC-SP6 Commercial Blast Cleaning for ferrous metal; ASTM D 6386-99 for galvanized; scarify non-ferrous metal; NAPF 500-03 for cast & ductile iron.	
b.	1 <sup>st</sup> Coat: Tnemec Series 1 Omnithane.	2.5 - 4.0
c.	2 <sup>nd</sup> Coat: Tnemec Series N69-Color Hi-Build Epoxoline II. (2-3 mil dft for galvanized and non-ferrous metal.)	4.0 - 6.0
d.	3 <sup>rd</sup> Coat: Tnemec Series 1075-Color Endura-Shield II.	<u>2.0 - 3.0</u> 8.5 - 13.0
2.	Interior, non-immersion: System Series N69 Hi-Build Epoxoline II.	
a.	Surface preparation: SSPC-SP6 Commercial Blast Cleaning for ferrous metal; ASTM D 6386-99 for galvanized; scarify non-ferrous metal; NAPF 500-03 for cast & ductile iron.	
b.	1 <sup>st</sup> Coat: Tnemec Series 1 Omnithane.	2.5 - 4.0
c.	2 <sup>nd</sup> Coat: Tnemec Series N69-Color Hi-Build Epoxoline II. (2-3 mil dft for galvanized and non-ferrous metal.)	4.0 - 6.0
d.	3 <sup>rd</sup> Coat: Tnemec Series N69-Color Hi-Build Epoxoline II. (2-3 mil dft for galvanized and non-ferrous metal.)	<u>4.0 - 6.0</u> 10.5 - 16.0
3.	Immersion, or subject to splash or spray of potable water: System Series N140 Pota-Pox Plus.	
a.	Surface Preparation: SSPC-SP10 Near White Metal Blast Cleaning. NAPF 500-03 for cast & ductile iron.	
b.	1 <sup>st</sup> Coat: Tnemec Series 1 Omnithane.	2.5 - 4.0

Dry Film - mils

- |    |   |                       |
|----|---|-----------------------|
| c. | 2 <sup>nd</sup> Coat: Tnemec Series N140-15BL Tank White Pota-Pox Plus.                                 | 3.0 - 5.0             |
| d. | 3 <sup>rd</sup> Coat: Tnemec Series N140-1255 Beige Pota-Pox Plus.                                      | 3.0 - 5.0             |
| e. | 4 <sup>th</sup> Coat: Tnemec Series N140-15BL Tank White Pota-Pox Plus.                                 | <u>3.0 - 5.0</u>      |
|    |   | 11.5 - 19.0           |
|    |   |                       |
| 4. | Immersion, or subject to splash or spray of non-potable water: System Series N69 Hi-Build Epoxoline II. |                       |
| a. | Surface Preparation: SSPC-SP10 Near White Metal Blast Cleaning. NAPF 500-03 for cast & ductile iron.    |                       |
| b. | 1 <sup>st</sup> Coat: Tnemec Series 1 Omnithane.  | 2.5 - 4.0             |
| c. | 2 <sup>nd</sup> Coat: Tnemec Series N69-Color Hi-Build Epoxoline II.                                    | 3.0 - 5.0             |
| d. | 3 <sup>rd</sup> Coat: Tnemec Series N69-Color Hi-Build Epoxoline II.                                    | 3.0 - 5.0             |
| e. | 4 <sup>th</sup> Coat: Tnemec Series N69-Color Hi-Build Epoxoline II.                                    | <u>3.0 - 5.0</u>      |
|    |   | 11.5 - 19.0           |
|    |   |                       |
| B. | Concrete:   |                       |
| 1. | Interior, exposed except floor: System Series N69 Hi-Build Epoxoline II.                                |                       |
| a. | Surface Preparation: SSPC SP-13, fill voids with Tnemec Series 218 MortarClad.                          |                       |
| b. | 1 <sup>st</sup> Coat: Tnemec Series N69-W6160 Hi-Build Epoxoline II.                                    | (80-100 sq. ft./gal.) |
| c. | 2 <sup>nd</sup> Coat: Tnemec Series N69-Color Hi-Build Epoxoline II.                                    | 3.0 - 4.0             |
| d. | 3 <sup>rd</sup> Coat: Tnemec Series N69-Color Hi-Build Epoxoline II.                                    | <u>3.0 - 4.0</u>      |
|    |   | (Topcoats) 6.0 - 8.0  |
| 2. | Interior floor: System #1 – Curing New Concrete to Harden and Dustproof.                                |                       |
| a. | Reference Section 03 30 00.   |                       |
|    |   |                       |
| C. | Concrete Block:   |                       |
| 1. | Interior: System Series N69 Hi-Build Epoxoline II.  |                       |
| a. | Surface Preparation: Allow new mortar to cure 28 days, level protrusions and mortar spatter.            |                       |
| b. | 1 <sup>st</sup> Coat: Tnemec Series N69-W6160 Hi-Build Epoxoline II.                                    | 75-100 sq. ft./gal.   |
| c. | 2 <sup>nd</sup> Coat: Tnemec Series N69-Color Hi-Build Epoxoline II.                                    | 3.0 - 4.0             |



Dry Film - mils

- d. 3<sup>rd</sup> Coat: Tnemec Series N69-Color Hi-Build Epoxoline II.

3.0 - 4.0  
(Topcoats) 6.0 - 8.0

D. Wood:

- 1. Interior and exterior: System Series 113 HB Tneme-Tufcoat.
  - a. Surface Preparation: Clean and dry.
  - b. 1<sup>st</sup> Coat: Tnemec Series 151-1051 Elasto-Grip FC.
  - c. 2<sup>nd</sup> Coat: Tnemec Series 113 H.B. Tneme-Tufcoat.
  - d. 3<sup>rd</sup> Coat: Tnemec Series 113 H.B Tneme-Tufcoat.

1.0 - 1.5

2.0 - 3.0

2.0 - 3.0

5.0 - 7.5

E. PVC:

- 1. Interior: System Series N69 Hi-Build Epoxoline II.
  - a. Surface Preparation: Hand Sand to Scarify.
  - b. 1<sup>st</sup> Coat: Tnemec Series N69-Color Hi-Build Epoxoline II.
  - c. 2<sup>nd</sup> Coat: Tnemec Series N69-Color Hi-Build Epoxoline II.
- 2. Exterior: System Series 1075 Endura-Shield II.
  - a. Surface Preparation: Hand Sand to Scarify.
  - b. 1<sup>st</sup> Coat: Tnemec Series N69-Color Hi-Build Epoxoline II.
  - c. 2<sup>nd</sup> Coat: Tnemec Series 1075 Endura-Shield II.

2.0 - 3.0

2.0 - 3.0

4.0 - 6.0

2.0 - 3.0

2.0 - 3.0

4.0 - 6.0

3.6 PIPELINE IDENTIFICATION COLORS AND LABELS

A. Paint pipelines including fittings and valves with the following color scheme:

- 1. Potable water lines: 11SF Safety Blue
- 2. Sewage lines: GR28 Fossil

END OF SECTION

SECTION 22 19 13  
PIPE AND PIPE FITTINGS

PART 1 - GENERAL

1.1 SUMMARY

- A. Provide pipe and pipe fittings as shown on the Drawings, as specified herein, and as needed for a complete and proper installation.
- B. Provide labor, materials, tools, chemicals and equipment necessary to perform the pressure and leakage tests and disinfection.
- C. Related work:
  - 1. Documents affecting work under this Section include, but are not necessarily limited to, General Conditions, Supplementary Conditions, and Division 01 - General Requirements of these Specifications.
  - 2. See specification Section 33 16 19.33, Concrete/Steel Composite Water Storage Tank for specific information regarding pipe and piping requirements for the water storage tank, which may exceed the requirements of this section.
- D. References:
  - 1. Reserved.

1.2 SUBMITTALS

- A. Shop Drawing Submittals – None Required.
- B. Operation and Maintenance Manuals – None Required.
- C. Certificates and Guarantees – None Required.
- D. Lubricants – None Required.
- E. Spare Parts – None Required.

1.3 QUALITY ASSURANCE

- A. Use adequate numbers of skilled workmen who are thoroughly trained and experienced in the necessary crafts and who are completely familiar with the specified requirements and the methods needed for proper performance of the work of this Section.
- B. Perform shop and field welding required in connection with the work of this Section in strict accordance with pertinent recommendations of the American Welding Society.
  - 1. Provide the services of an independent testing laboratory to take and test weld specimens or otherwise test welds to verify proper welding procedures as required by the Engineer.

## 1.4 DELIVERY, STORAGE, AND HANDLING

- A. Comply with pertinent provisions of Section 01 66 11.

## 1.5 SITE CONDITIONS – Reserved.

## 1.6 MAINTENANCE – Reserved.

## PART 2 - PRODUCTS

### 2.1 DUCTILE IRON PIPE (DIP) AND FITTINGS

#### A. Flanged joint pipe and fittings:

1. Pipe: Comply with ANSI A21.51, thickness Class 53 with pipe flanges faced and drilled to ANSI Class 125 standard template unless otherwise designated on the Drawings.
2. Fittings: Comply with ANSI A21.10 or ANSI B16.1.
3. Flange gaskets: 1/16-inch thick sheet rubber, full face type or 1/8-inch thick Full Faced American Toruseal flange gasket.
4. Flange bolts, studs, and nuts:

#### B. Mechanical joint pipe, push-on joint pipe:

1. Pipe: Comply with ANSI A21.51, thickness Class 52 unless otherwise designated on the Drawings.
2. Pipe joints: Comply with ANSI A21.11 for rubber gasket type.
3. Provide restrained joint pipe system at all pipe joints and fittings, that utilizes one of the following methods:
  - a. Lock rings welded into place around pipe barrel.
  - b. Bolted rings installed around pipe barrels that fit inside pipe bells.
  - c. Gaskets which include stainless steel locking segments vulcanized into the gasket.
  - d. Mechanical joint retainer gland systems that provide locking segments shaped to pipe barrel that do not create stress points on pipe barrel.
    - (1) Do not use setpoint type retainer glands.
  - e. Acceptable products:
    - (1) American Fastite, Flex-ring, Lok-ring, and MJ coupled joint.
    - (2) Clow Tyton Joint – Type A or Type B, and Super - Lock.
    - (3) U.S. Pipe TR-Flex Gripper.
    - (4) Griffin Bolt Lok or Snap Lok.
    - (5) Field Lok or Fast Grip Gasket Systems.
    - (6) Meg-A-Lug System.
      - i. Series 1100 Megalug for MJ to pipe.
      - ii. Series 1700 Megalug Harness for push on joint.
      - iii. As recommended by manufacturer for connection to existing pipes.

- C. Except for digester gas piping, provide cement lining for all ductile iron pipes and pipe fittings complying with ANSI A21.4, standard thickness.
  - 1. For digester gas piping, provide unlined ductile iron pipe and pipe fittings.
- D. Fittings:
  - 1. Use ductile iron fittings with mechanical joint complying with ANSI A21.10 or A21.53.
  - 2. Use cement lining complying with ANSI A-21.4, standard thickness.
  - 3. Bolts and nuts:
    - a. Use 316 stainless steel bolts, nuts and washers.
  - 4. Provide restrained joint type fittings that are compatible with system utilized, as specified by the pipe manufacturer.
- E. Polyethylene sheet: Comply with ANSI/AWWA A 21.5-99/C105:
  - 1. Thickness: linear low-density polyethylene film (minimum 8 mils) or high-density cross laminated polyethylene film (minimum 4 mils).
  - 2. Markings: The following information will be clearly marked on the sheet at minimum increments of 2 feet along its length:
    - a. Manufacturers name or trademark.
    - b. Year of manufacture.
    - c. Min. film thickness and material type (LLDPE or HDCLPE).
    - d. Applicable range of nominal pipe diameter size(s).
    - e. Warning – Corrosion Protection – Repair any damage.
- F. Conductivity appurtenances:
  - 1. Provide wedges of serrated silicon bronze: or #10-copper cable and tapping devices specifically designed for this purpose.
  - 2. Use devices provided by the pipe manufacturer.
  - 3. Standard mechanical joints, field lok, or meg-a-lug do not provide conductivity.

## 2.2 CORPORATION AND CURB STOPS

- A. Corporation stop shall be Mueller H-100003.
- B. Curb stop shall be Mueller H-15201.

## 2.3 CAST IRON SOIL PIPE (CISP) AND FITTINGS

- A. Pipe and fittings: Service weight, hub and spigot type conforming to ANSI A112.5.2.
- B. Joints: Use either the caulked lead and oakum type or the rubber compression gasket type.

## 2.4 IPS CAST IRON PIPE

- A. Comply with ANSI A40.5.

## 2.5 STEEL PIPE AND FITTINGS

- A. Welded steel pipe and fittings:
1. Pipe: Comply with ASTM A-53 and AP1-5L for black seamless and welded pipe.
    - a. Pipe sizes 12-inch diameter and smaller: ASA Schedule 40 weight and wall thickness.
    - b. Pipe sizes 14-inch and larger: ASA Standard weight and 0.375-inch wall thickness.
  2. Pipe flanges and fittings: Continuous weld type conforming to ANSI B16.5.
  3. Connections: Continuous butt weld type.
    - a. Welding procedures: Conform to ANSI B31.1.
    - b. Minimum yield strength of welded joints: 35,000 psi.
  4. Provide extruded plastic coatings, Standard X-TRU-COAT, or equal, for underground steel pipe.
    - a. Make field joints and repairs with thermofit pipe sleeves, or primer and plastic, or hot applied coal tar tapes.
- B. Galvanized steel pipe and fittings:
1. Pipe: Comply with ASTM A-53, ASA Schedule 40 weight and wall thickness.
  2. Fittings: Use 150-pound galvanized malleable iron screwed end fittings.
- C. Stainless steel pipe and fittings:
1. Pipe sizes 2½-inch and smaller:
    - a. Comply with ASTM A-312, Schedule 40, Type 316L seamless stainless steel pipe.
    - b. Fittings: Use 150 LB. 316 stainless steel screwed fittings.
    - c. In lieu of screwed fittings, Victaulic Vic-Press 304 System may be used.
      - (1) Provide pipe that is approved for use with the Vic-Press 304 system.
      - (2) O-Rings: Grade "E" EPDM (green color code).
      - (3) Ball valves: see Section 22 19 23.
      - (4) Pipe supports: provide supports as specified in Part 3 of this Section and do not exceed spans recommended by Victaulic for the Vic-Press 304 system.
  2. Pipe sizes 3-inch and larger:
    - a. Piping system: Mechanical Grooved Piping System conforming to ANSI-B-31.1, B-31.3, AND B-31.9.
    - b. Pipe: comply with ASTM A-778, Schedule 10, Type 304L welded unannealed austenitic stainless steel pipe.
    - c. Fittings: smooth turn, full flow Type 304L stainless steel fittings or segmentally welded fittings with grooves designed to accept to specified couplings.
    - d. Joints:
      - (1) Rolled or cut-grooved-ends as appropriate to pipe material, wall thickness, pressures, size, and method of joining.
      - (2) Groove pipe ends in accordance with ANSI/AWWA C-606.

- e. Couplings 3" to 12":
  - (1) Victaulic Style 489 stainless steel rigid coupling, or equal.
  - (2) Meet requirements of ASTM F-1476.
  - (3) Housing: Type 316 stainless steel, conforming to ASTM A-351, A-743, and A-744 Grade CF-8M.
  - (4) Housing coating: none.
  - (5) Gaskets: Grade "E" EPDM (green color code) compound conforming to ASTM D-2000 designation 2CA615A25B24F17Z.
  - (6) Bolts and nuts: Type 316 stainless steel, oval neck track bolts and heavy hexagonal nuts with chemical and physical properties of ASTM F-593, Group 2, Condition CW.
- f. Couplings 14" and over:
  - (1) Provide flexible couplings as specified later in this Section.

## 2.6 POLYVINYL CHLORIDE PIPE

- A. General:
  - 1. Make polyvinyl chloride (PVC) pipe and fittings of Class 12454B material conforming to ASTM D1784.
- B. PVC pressure pipe and fittings:
  - 1. Use Schedule 80 with a minimum pressure rating of 125 psi at 73 degrees F, conforming to ASTM D1785.
  - 2. Joints: Use solvent-weld socket type, threaded type, or flanged type.
- C. PVC plastic sewer pipe:
  - 1. For pipe and fittings 4-inch through 15-inch:
    - a. Comply with ASTM D3034 for Type PSM polyvinyl chloride (PVC) sewer pipe and fittings of minimum wall thickness SDR 26.
    - b. Joints: Use either the solvent-weld type complying with ASTM D2564 and ASTM D2855, or the elastomeric gasket type complying with ASTM F477 AND ASTM D3212.
    - c. Fittings in sizes through 8-inch: Molded in one piece with elastomeric joints and minimum socket depths as specified in Section 6.2 and 7.3.2 of ASTM D3034.
    - d. Fittings 10-inch and larger: Molded or fabricated in accordance with Section 7.11 of ASTM D3034 with manufacturer's standard pipe bells and gaskets.
    - e. Gaskets for fittings and joints: Provide minimum cross-sectional area of 0.20 square inches complying with ASTM F477.
  - 2. For pipe and fittings 18-inch through 36-inch:
    - a. Comply with ASTM F679 for polyvinyl chloride (PVC) large diameter heavy wall gravity sewer pipe and fittings.
      - (1) Corresponding to SDR 26 (pipe stiffness = 115 psi).
    - b. Joints: Use integral bell gasketed type with elastomeric gaskets to form a watertight seal complying with ASTM F477 or ASTM D3212.

3. Branch fittings: Use either factory fabricated type with attached main line coupling, or solvent welded saddle type attached to the pipe with cement and held in place with stainless steel bands.
  - a. Branch fittings: SDR 26.
    - (1) Acceptable manufacturers:
      - i. GPK Products.
      - ii. Harco.
      - iii. Multi Fittings.
      - iv. Plastic Trends.
      - v. Sealtite Sewer Saddles by Geneco.
      - vi. Or equal.
4. Risers and service pipe and fittings: Use SDR 26, solid wall type complying with ASTM D3034 for PVC pipe.

## 2.7 PLASTIC DRAINAGE PIPE AND FITTINGS

- A. Use either Schedule 40 PVC-DWV or ABS-DWV conforming to ASTM D2661 or D2665 and bearing the National Sanitation Foundation seal of approval.
- B. Fittings: Use molded, fully recessed, socket type with solvent welded joints or O-ring type joints.
  1. Special purpose threaded or flanged adapter fittings, couplings, and unions may be used, provided that they are fully recessed and create no restriction to flow greater than conventional fittings.

## 2.8 WALL PIPES, SLEEVES, AND SEALS

- A. Wall pipes:
  1. Use cast iron mechanical joint type with rubber gaskets and flanges tapped for studs, or ANSI Class 125 flange type with flanges tapped for studs.
- B. Wall sleeves:
  1. Cast iron wall sleeves: Use mechanical joint type with flanges tapped for studs.
  2. Steel wall sleeves: Fabricate sleeve from Schedule 40 black steel pipe.
- C. Link seals:
  1. Use modular mechanical type consisting of interlocking solid rubber links designed for positive hydrostatic pressure of 20 psig.
    - a. Connect each pair of links by a carbon steel zinc phosphate plated bolt and nut each with a heavy Delrin plastic elongated washer.
  2. Acceptable product: "LINK-SEAL" as manufactured by Thunderline Corp. and supplied by Maddock Mechanical Industries, Inc., Chicago, IL, or equal.
- D. Provide integral intermediate water stop wall collars for all wall pipes and sleeves.

## 2.9 FLEXIBLE COUPLINGS AND FLANGED ADAPTERS

- A. Flexible couplings:
  1. Use slip ring sleeve type with rubber gaskets, tightening flanges and high strength bolts and nuts, Dresser Style 38, or equal.

2. Provide two tie-rods for each coupling to secure the coupling to the adjacent pipe fitting.

B. Flanged adapters:

1. Use steel fabricated type, Dresser Style 128, or equal.

## 2.10 MECHANICAL GROOVED PIPE JOINTS

A. Mechanical grooved pipe couplings and fittings may be used in lieu of flanged or screwed end joints for all piping systems.

1. Fabricate couplings and fittings in two or more parts of malleable iron conforming to ASTM A47, Grade 32510.
2. Coupling gaskets: Molded synthetic rubber conforming to ASTM D2000, Grade 3BA615A14B13.
3. Bolts: Oval neck track head type with hexagonal nuts conforming to ASTM A183 and A194.
4. Make grooved and shouldered ends of piping in accordance with the manufacturer's recommendations.

## 2.11 INSULATING COUPLINGS

A. Provide insulating couplings for dielectric protection from electrolytic corrosion on piping where dissimilar metals (copper to steel, etc.) are joined.

1. Use inert, non-conductive, linen-impregnated laminate material for lining with standard NPS threaded ends.
2. Acceptable products: Lochinvar V-Line Insulating Couplings, or equal.

## 2.12 RESTRAINED FLANGE ADAPTOR

A. Provide a ductile iron flange adaptor dual ring system with bolt circles compatible with 125#/Class 150 bolt pattern.

1. Provide adaptor with individual actuated gripping wedges that utilize torque limiting screws to insure proper initial set.
2. Set screw "only" restraining adaptors are not acceptable.
3. Provide system that allows joint deflection of up to 5°.
4. Provide a fluoropolymer coating to the wedge and wedge assembly and powder coating to the restraint body.

B. Acceptable manufacturers:

1. Series 2100 Megaflange by Ebaa Iron;
2. Or approved equal.

## PART 3 - EXECUTION

### 3.1 FIELD MEASUREMENTS

A. Make necessary measurements in the field to assure precise fit of items in accordance with the Drawings.



### 3.2 INSTALLATION OF PIPING

#### A. General:

1. Trench, backfill, and compact for the work of this Section in strict accordance with pertinent provisions of Section 31 23 79 of these Specifications, and City of Madison Water Utility Standards, Detail Drawing No. 7.01, attached to the back of this Section.
  - a. Install pipe in accordance with pipe manufacturer's recommendations.
  - b. Lay pipe by proceeding upgrade with the spigot ends of bell-and-spigot pipe pointing in direction of flow.
  - c. Use proper and suitable tools and appliances for safe and convenient handling and installation of piping.
  - d. Continually clear interior of the pipe free from foreign material.
  - e. Before making pipe joints, clean and dry all surfaces of the pipe to be joined.
  - f. Use lubricants, primers, and adhesives recommended for the purpose by the pipe manufacturer.
  - g. Comply with ASTM D2321 for flexible thermoplastic sewer pipe installation.
  - h. Make adequate provision for expansion and contraction of piping.

#### B. Water main separation:

1. Whenever water mains are encountered in the course of piping installation, notify the Engineer to determine the construction necessary to comply with the provisions of the "Standard Specifications for Sewer and Water Construction in Wisconsin".

#### C. Install unions or flanges at piping connections to each piece of equipment, at intervals of not more than 50 feet in straight runs of threaded pipe, at each valve, and wherever else required to disassemble piping for service of fittings, fixtures, equipment and appurtenances.

1. Use unions in piping sizes 3 inches and smaller.
2. Use flanges in piping sizes larger than 3 inches.
3. Make connections between ferrous and non-ferrous metal piping with dielectric type insulated unions or flanges.

### 3.3 PIPING SUPPORTS

#### A. General:

1. Design and provide complete system of supports and anchors for all piping, fittings, valves, fixtures and appurtenances.
2. Absence of pipe supports and details on the Drawings shall not relieve the Contractor of responsibility for providing them.
3. Design pipe support system to withstand dead loads imposed by weight of pipes filled with water plus test pressure and insulation (if required), with a minimum safety factor of 5.
4. Paint pipe supports in accordance with Section 09 90 00.

B. Types of support:

1. Piping adjacent to walls may be supported or braced by wall brackets.
2. Floor pipe supports: Use adjustable with floor flanges, pipe stanchion, and saddle where they do not obstruct passage.
3. Ceiling supported pipe hangers: Use adjustable steel clevis type with full diameter hanger rods conforming to the following sizes:

<u>Pipe Size</u>	<u>Minimum Rod Size</u>
1/2" - 2"	3/8"
2-1/2" - 3-1/2"	1/2"
4" - 5"	5/8"
6" - 12"	7/8"
14" - 16"	1"
18" - 20"	1-1/4"
24" - 30"	1-1/2"

C. Support spacing:

1. For rigid pipes except PVC pipes:

<u>Pipe Size</u>	<u>Maximum Spacing</u>
1/2" - 2"	6'
2-1/2" - 3-1/2"	8'
4" - 5"	8'
6" - 12"	9'
14" - 16"	9'
18" - 20"	9'
24" - 30"	9'

2. For PVC Schedule 80 pipes:

<u>Pipe Size</u>	<u>Maximum Spacing</u>
3/4" and smaller	continuous rigid support
1" - 1-1/2"	4'
2" - 2-1/2"	5'
3"	6'
4" and larger	7'

3. For flexible hose and tubing:
  - a. Provide continuous support by means of rigid carrier pipes or troughs consisting of structural channels or angles which are supported at intervals of 10 feet or less.
4. Provide a minimum of two pipe supports for each pipe run.

D. Thrust anchors and guides:

1. Provide thrust anchors and guides to resist thrust due to changes in pipe sizes or direction, or dead end of pipes.

### 3.4 PIPE RESTRAINING SYSTEMS FOR UNDERGROUND PRESSURE PIPING

A. General:

1. Provide protection from movement of pressure piping, plugs, caps, tees, valves, hydrants, and bends of 11-1/4 degrees or greater.

2. Provide concrete thrust blocks at all locations noted in A.1 and as shown on City of Madison Water Utility Standards, Detail Drawing No.7.13, attached to the back of this Section.
3. Where restrained joint type fittings are called for on the Drawings, but cannot be utilized, provide concrete thrust blocks.

B. Concrete thrust blocks:

1. Provide precast or cast-in-place concrete thrust blocking with a compressive strength of 3000 psi in 28 days.
2. Locate thrust blocking between solid ground and the fitting to be anchored.
3. Unless otherwise shown or directed by the Engineer, place the base and thrust bearing sides of thrust blocking directly against undisturbed earth.
4. Sides of thrust blocking not subject to thrust may be placed against forms.
5. Place thrust blocking so the fitting joints will be accessible for repair.
6. When conditions prevent the use of concrete thrust blocks, use tie rods or restrained joints of an approved type.

C. Restrained type pipe and fittings:

1. Provide restraining system as outlined in Part 2 of this Section or utilize metal tie rods, clamps, and lugs to prevent pipe and appurtenances from movement.
  - a. Protect tie rods and clamps with epoxy or bituminous paint.
  - b. Protect all restrainers used for PVC fittings with a double layer of polyethylene wrapping or tubing.
2. Where utilizing restrained joint pipe system to immobilize joints or fittings, provide restrained joint pipe to distance indicated on the Drawings, or not less than a minimum of three pipe lengths on each side of the bend or fitting to be restrained.

### 3.5 POLYETHYLENE WRAPPING OF DUCTILE IRON PIPE AND APPURTENANCES

- A. Comply with requirements of ANSI/AWWA C105/A21.5-99 and City of Madison Water Utility Standards, Detail Drawing No. 7.02, attached to the back of this Section.
1. Place polyethylene sheet around the entire circumference of the pipe, tie or tape sheet securely to prevent displacement during backfilling.
  2. Wrap all water mains, fittings, valves, fire hydrant leaders, fire hydrants, service lines, or other pipe where indicated on the Drawings.
    - a. Wrap copper service lines to a point 3 feet from center of water main.
    - b. Do not block fire hydrant weep hole.

### 3.6 CONDUCTIVITY APPURTENANCES

- A. Install conductivity through joints by use of conductivity wedges or copper cable and taps.
1. Use two (2) wedges per joint for pipes 12 inches or smaller, and four (4) wedges per joint for pipe sizes larger than 12 inches.
  2. Use number of copper cable connectors per joint as recommended by the pipe manufacturer.

### 3.7 CORPORATION AND CURB STOPS

- A. Install corporation and curb stops in accordance with City of Madison Water Utility Standards, Detail Drawing No. 7.10, attached the back of this section.
- B. Locate curb box near 16-inch tank isolation valve.

### 3.8 TESTING AND INSPECTING

- A. Hydrostatic tests:
  - 1. Where any section of a pressure piping is provided with concrete thrust blocking, do not make hydrostatic tests until at least 5 days after installation of the concrete thrust blocking, unless otherwise directed by the Engineer.
  - 2. Devise a method for disposal of waste water from hydrostatic tests, and for disinfection, as approved in advance by the Engineer.
- B. Testing of pressure piping:
  - 1. Subject the pressure piping to the following hydrostatic pressure:
    - a. Water, sewage, and sludge piping with a normal operating pressure of 20 psig or greater: 125 psig.
    - b. Water, sewage, and sludge piping with a normal operating pressure of less than 20 psig: 50 psig.
    - c. Water, sewage, and sludge pump suction piping: Negative pressure of 7 psig.
    - d. Air and gas piping: Pneumatic pressure of 15 psig.
  - 2. Hold the test pressure for a duration of 30 minutes without pressure loss or further pressure application.
  - 3. Replace or remake joints showing visible leakage.
  - 4. Remove cracked pipe, defective pipe, and cracked or defective joints, fittings, and valves. Replace with sound material and repeat the test until results are satisfactory.
  - 5. Make repair and replacement without additional cost to the Owner.
  - 6. Do not test against existing valves.
- C. Testing of non-pressure piping:
  - 1. Test all non-pressure piping for watertightness by the low pressure air testing, or exfiltration, or infiltration method as selected by the Engineer.
  - 2. Low pressure air test:
    - a. Prior to testing for leakage, flush and clean the lines by passing a snug-fitting inflated rubber ball through the line by upstream water pressure.
    - b. Seal pipe openings with airtight plugs and braces.
    - c. Whenever the line to be tested is submerged under groundwater, insert a pipe probe by boring or jetting into the backfill material adjacent to the center of the line to determine the groundwater hydrostatic pressure by forcing air to flow slowly through the probe pipe.

- d. Add air to the plugged pipe sections under test until internal air pressure reaches 4.0 psig greater than any groundwater hydrostatic pressure.
  - e. Allow at least two minutes for air temperature to stabilize and adding air to maintain the initial test pressure.
  - f. Shut off the air supply after stabilizing the air temperature and record the time in seconds using an approved stopwatch for the internal pressure to drop from 3.5 psig to 2.5 psig greater than any groundwater hydrostatic pressure.
  - g. Allowable limits: Total rate of air loss not to exceed 0.0030 cubic feet of air per minute per square foot of internal pipe area.
  - h. If the air test fails to meet these requirements, locate and repair, or remove and replace the faulty sections of pipe in a manner approved by the Engineer, as necessary to meet the allowable limits upon retesting.
  - i. Do not use acrylamid gel sealant to correct leakage.
3. Water exfiltration tests:
- a. Seal the section of pipe to be tested by inserting inflatable rubber stoppers or by other means approved by the Engineer.
  - b. Fill the pipe with water to a point two feet above the top of the pipe at the upper end; or, if groundwater is present, two feet above the average adjacent groundwater level for a period of not less than 24 hours prior to measuring leakage.
  - c. Measure the leakage by the amount of water added to maintain the water level at that level for a period as required by the Engineer but not less than one hour.
4. Water infiltration test:
- a. If, in the opinion of the Engineer, excessive groundwater (a minimum of 24 inches above the top of the pipe) is encountered in the construction of a section of the pipe, the exfiltration test shall not be used.
  - b. Close the end of the pipe at the upper structure sufficiently to prevent the entrance of water.
  - c. Pump out groundwater in the pipe to allow the infiltration to come to equilibrium, then test for infiltration.
5. Allowable limits for water infiltration or exfiltration test: Not to exceed 200 gallons per inch of pipe diameter per 24 hours per mile of pipe.
6. Provide and use measuring devices approved by the Engineer.
7. Provide materials, and labor for making required tests.
8. Make tests in the presence of the Engineer, giving the Engineer at least three days advance notice of being ready for test observation.

### 3.9 WATER SYSTEM DISINFECTION

#### A. General:

- 1. After the potable water system has been satisfactorily completed and tested, disinfect the work in accordance with AWWA C651, and "Standard Specifications for Sewer and Water Construction in Wisconsin".

- B. Forms of applied chlorine:
1. Apply chlorine by the dry gas feeder unless solution feed chlorination, solution of chlorine-bearing compounds, or tablet method are approved by the Owner.
    - a. Provide effective diffusion of the gas into the water within the water main and regulating the rate of gas flow.
    - b. Provide means for preventing the backflow of water into the chlorinator.
  2. Chlorine-bearing compounds in water:
    - a. Apply solution of calcium hypochlorite granular or sodium hypochlorite into one end of the section of main to be disinfected while filling the main with water.
  3. Tablet method:
    - a. Apply tablet of calcium hypochlorite to short extensions only.
    - b. Utilize only when scrupulous cleanliness has been used in construction.
    - c. Do not use if trench water or foreign material has entered the water piping or if the water is below 41 degrees F. Place tablets at the top of the main and attach by an adhesive, such as Permatex No. 1.
    - d. Place crushed tablets inside the annular space of the pipe joints.
- C. Requirement of chlorine:
1. Apply disinfecting solutions having at least 50 mg/l of available chlorine.
  2. Retain the disinfecting solutions in the work for at least 24 hours.
  3. Chlorine residual after the retention period: At least 25 mg/l.
- D. Flushing and testing:
1. Following chlorination, flush treated water thoroughly from the water system until the chlorine concentration in the water flowing from the system is no higher than generally prevailing in the Owner's system, or less than 1 mg/l.
  2. After flushing, the Owner will collect two samples on successive days at least 24 hours apart in sterile bottles treated with sodium thiosulfate. Notify the Engineer and Owner when leakage testing is complete and schedule the time for sample collection with the Owner. Provide materials and support to the Owner in collection of samples.
  3. The Owner will deliver the samples to a state approved laboratory for bacteriological analysis.
  4. Should the initial disinfection result in an unsatisfactory bacterial test, repeat the chlorination procedure until satisfactory results are obtained.
  5. The Owner will provide the water for initial flushing and testing only. Compensate the Owner for water used in subsequent flushing and testing.
- E. Swabbing:
1. Flush and swab the piping, valves, and fittings that must be placed in service immediately and cannot be disinfected by the above specified methods, with five percent solution of calcium hypochlorite prior to assembly.
    - a. Secure the Engineer's approval before applying this method of disinfection.

### 3.10 DECHLORINATION

- A. Comply with AWWA C651-05 requirements to neutralize the residual chlorine in new water mains.
- B. After new water mains have passed disinfection requirements, utilize portable diffusing dechlorinators that utilize sulfur dioxide or other chemicals listed in Appendix C of AWWA C651 to lower chlorine residuals prior to discharge to the drainage system.
  - 1. Lower concentration to 1 mg/l or less.

END OF SECTION

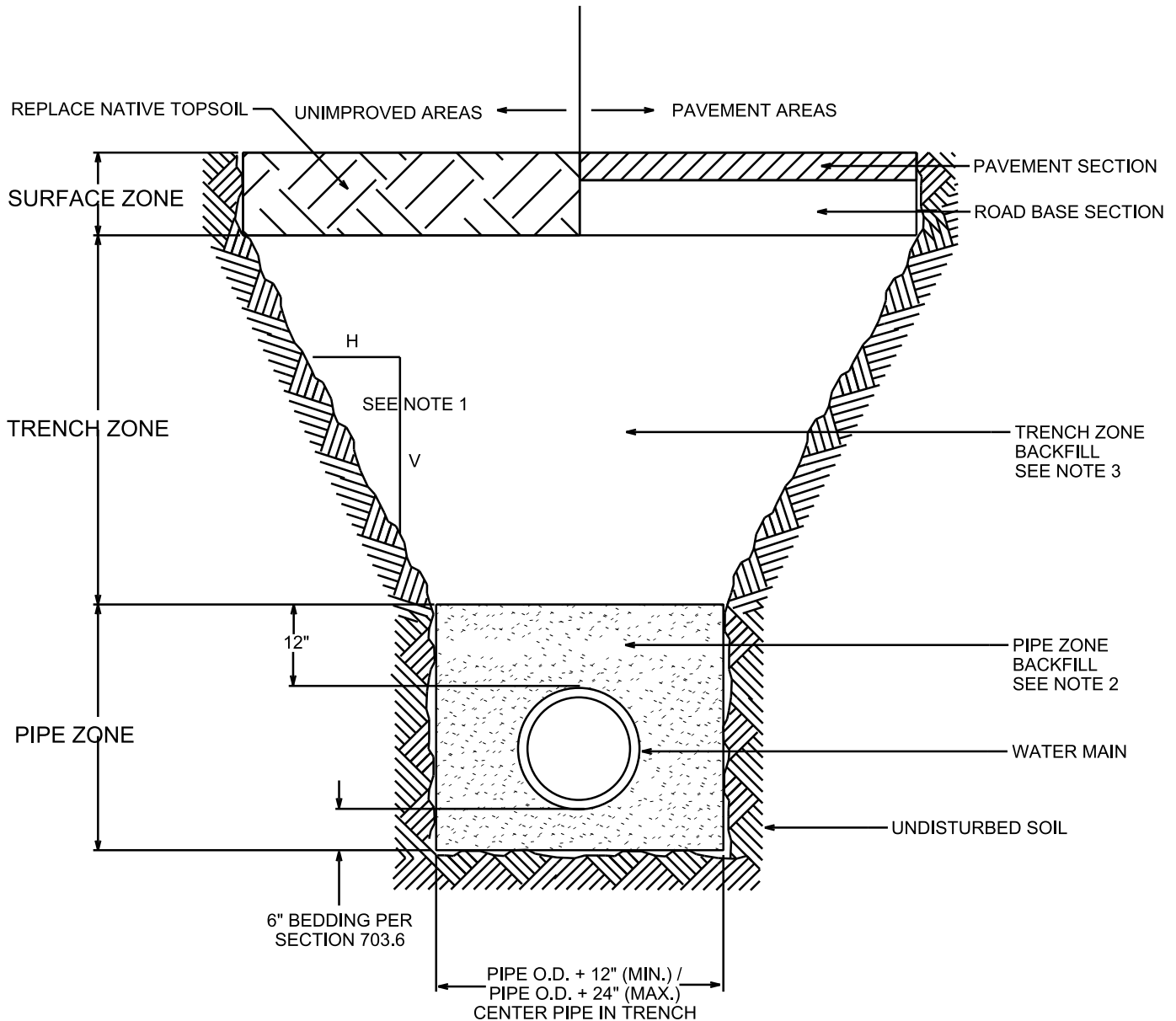

**NOTES:**

- 1) ALL EXCAVATION SHALL BE IN ACCORDANCE WITH THE WISCONSIN ADMINISTRATIVE CODE FOR "TRENCH EXCAVATION AND TUNNEL CONSTRUCTION" AND ANY ADDITIONAL REQUIREMENTS INCLUDING IN THE CONTRACT DOCUMENTS.
- 2) BACKFILL OPERATIONS SHALL COMPLY WITH SECTIONS 703.6 AND 202.2(B) OF THE STANDARD SPECIFICATIONS.
- 3) THE PIPE ZONE BEDDING MATERIAL SHALL CONSIST OF SELECT FILL SAND, LIMESTONE SCREENINGS, CLEAR STONE, OR WASHED GRAVEL.
- 4) SEE SECTION 703.6.1 FOR BACKFILL/COMPACTION REQUIREMENTS OF BEDDING/COVER MATERIAL IN THE PIPE ZONE.
- 5) TRENCH ZONE COMPACTION REQUIREMENTS:
  - ALL COMPACTION OPERATIONS SHALL COMPLY WITH SECTION 703.6.3
  - DENSITY REQUIREMENTS:
    1. FROM 2-FEET OVER THE PIPE TO WITHIN 3-FEET OF THE SUBGRADE:  
A MINIMUM OF 90% OF MAXIMUM DENSITY.
    2. WITHIN 3-FEET OF THE BOTTOM OF SUBGRADE:  
A MINIMUM OF 95% OF MAXIMUM DENSITY.

CITY OF MADISON  
WATER UTILITY

NOT TO SCALE

TYPICAL WATER PIPE TRENCH



**FIELD INSTALLATION-POLYETHYLENE WRAP**

**STEP-1**

CLEAN SURFACE OF PIPE. CUT POLYETHYLENE TWO FEET LONGER THAN THE PIPE (8 MIL MIN.). PLACE TUBE OF POLYETHYLENE MATERIAL AROUND PIPE PRIOR TO LOWERING PIPE INTO TRENCH. DIG BELL HOLES AT JOINTS, LOWER PIPE.

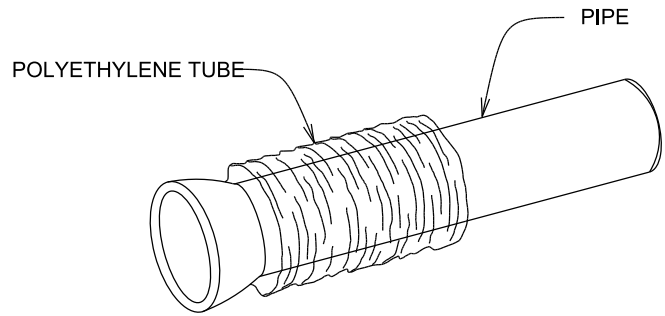

**STEP-2**

LIFT ENOUGH TO PULL THE TUBE OVER THE PIPE. TAPE TUBE TO PIPE AT JOINT. FOLD MATERIAL AROUND THE ADJACENT SPIGOT END AND WRAP WITH THREE CIRCUMFERENTIAL TURNS OF TWO-INCH WIDE PLASTIC TAPE TO HOLD PLASTIC TUBE AROUND SPIGOT END.

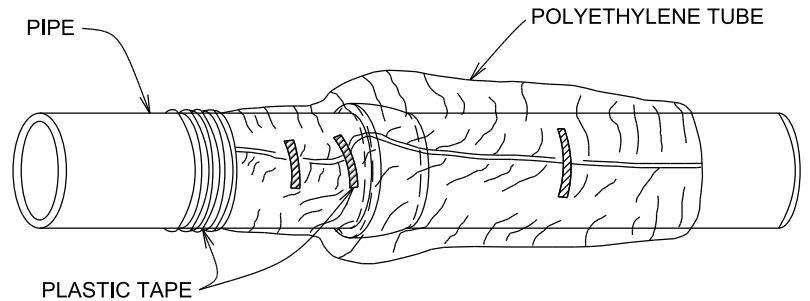

**STEP-3**

ADJACENT TUBE OVERLAPS FIRST TUBE AND IS SECURED WITH PLASTIC ADHESIVE TAPE. THE POLYETHYLENE TUBE MATERIAL COVERING THE PIPE WILL BE LOOSE. EXCESS MATERIAL SHALL BE NEATLY DRAWN UP AROUND THE PIPE BARREL, FOLDED INTO AN OVERLAP ON TOP OF THE PIPE AND HELD IN PLACE BY MEANS OF PIECES OF THE PLASTIC TAPE AT APPROX. THREE FOOT INTERVALS. REPAIR ANY TEARS WITH TAPE OR SECURED POLYWRAP PATCHES. CAREFULLY BACKFILL TO AVOID DAMAGING THE POLYETHYLENE WRAP.

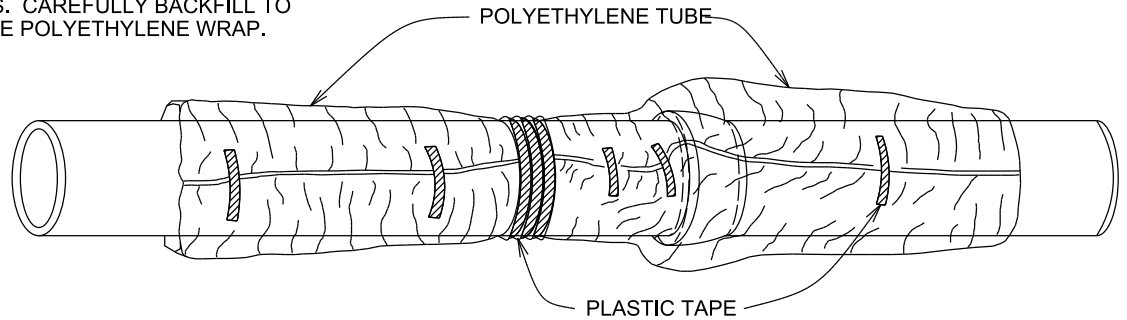

**TAPPING POLYETHYLENE WRAP**

**STEP-1**

WRAP TWO OR THREE LAYERS OF TAPE COMPLETELY AROUND PIPE WHERE TAPPING MACHINE WILL BE PLACED. MOUNT TAPPING MACHINE ON TAPED AREA AND TAP DIRECTLY THROUGH THE TAPE AND POLYETHYLENE WRAP. INSTALL CORPORATION STOP. INSPECT AREA FOR DAMAGE AND REPAIR IF NECESSARY. WRAP COPPER SERVICE LINE WITHIN THREE FEET OF PIPE LOCATION.

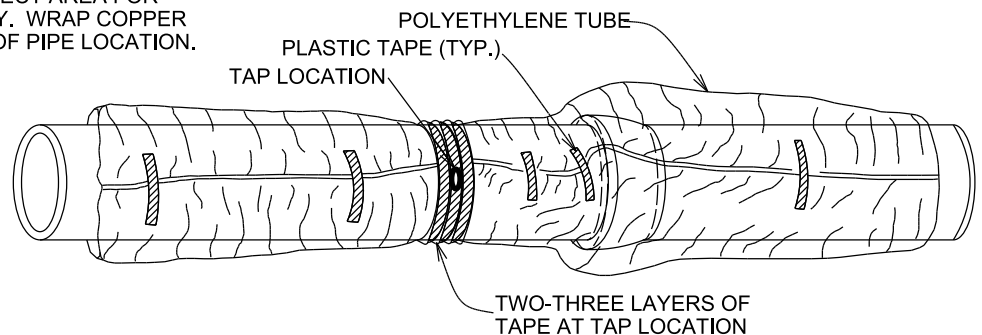

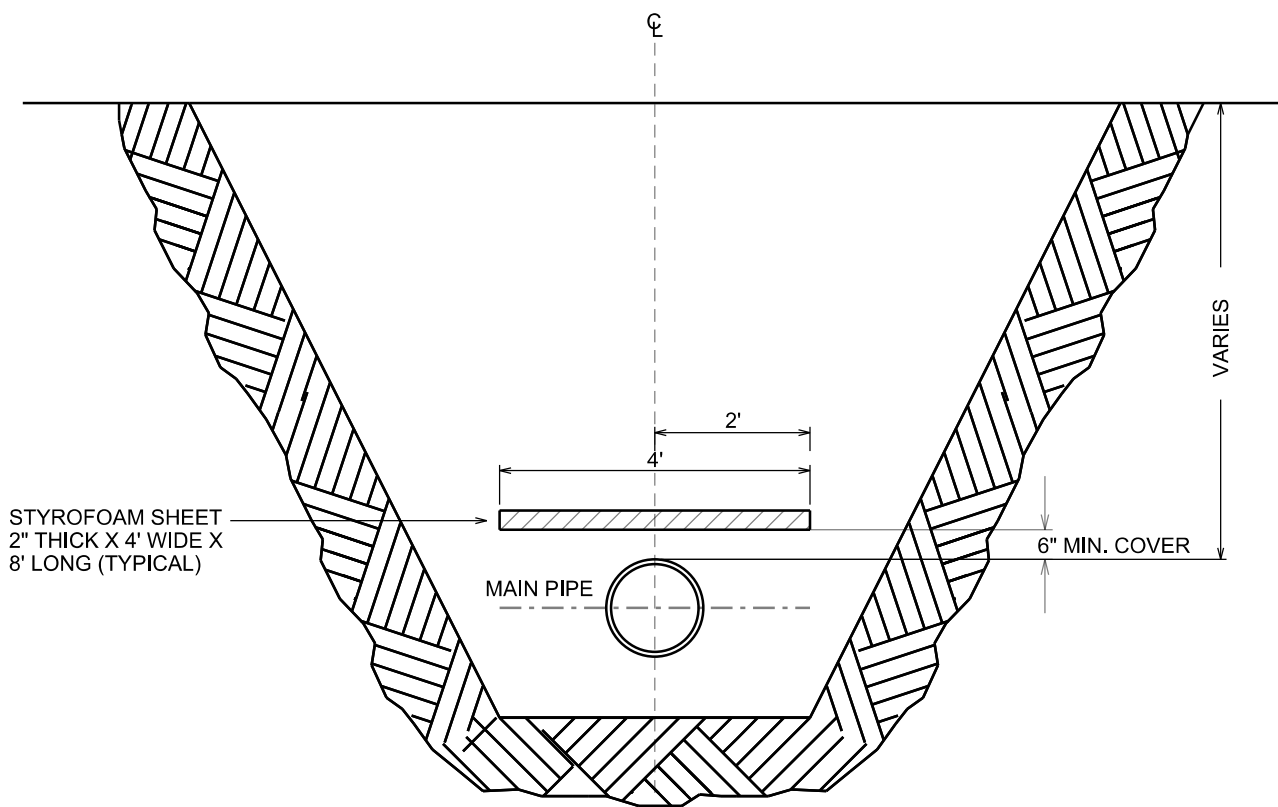

NOTE: ALL STYROFOAM TO BE 2" THICK  
HIGH DENSITY POLYSTYRENE BOARD

CITY OF MADISON  
WATER UTILITY

NOT TO SCALE

TYPICAL STYROFOAM  
INSTALLATION

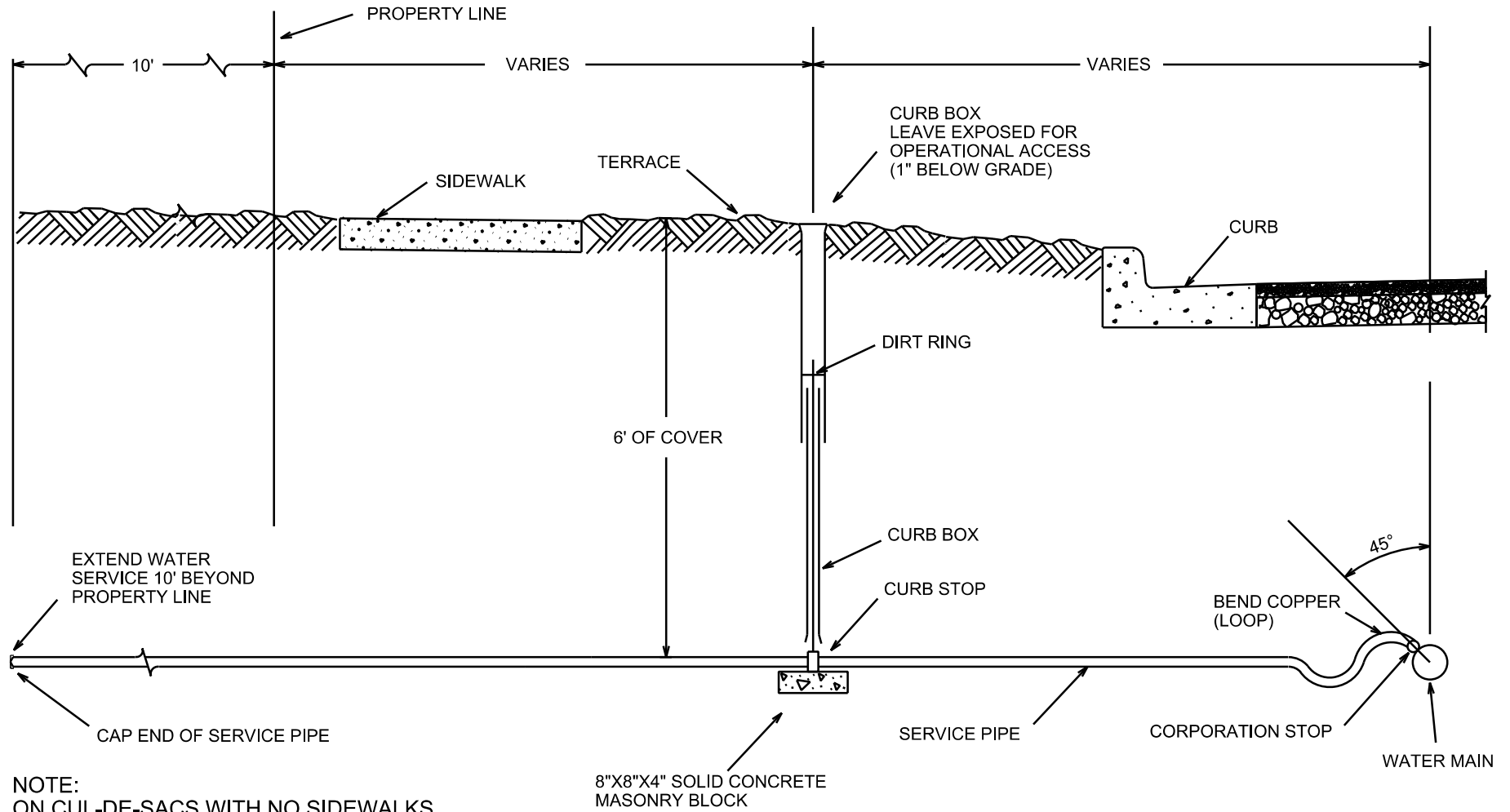

NOTE:  
ON CUL-DE-SACS WITH NO SIDEWALKS,  
WATER SERVICE PIPE TO END AT  
PROPERTY LINE.

CITY OF MADISON  
WATER UTILITY

NOT TO SCALE

SERVICE INSTALLATION -  
PRIVATE CONTRACT

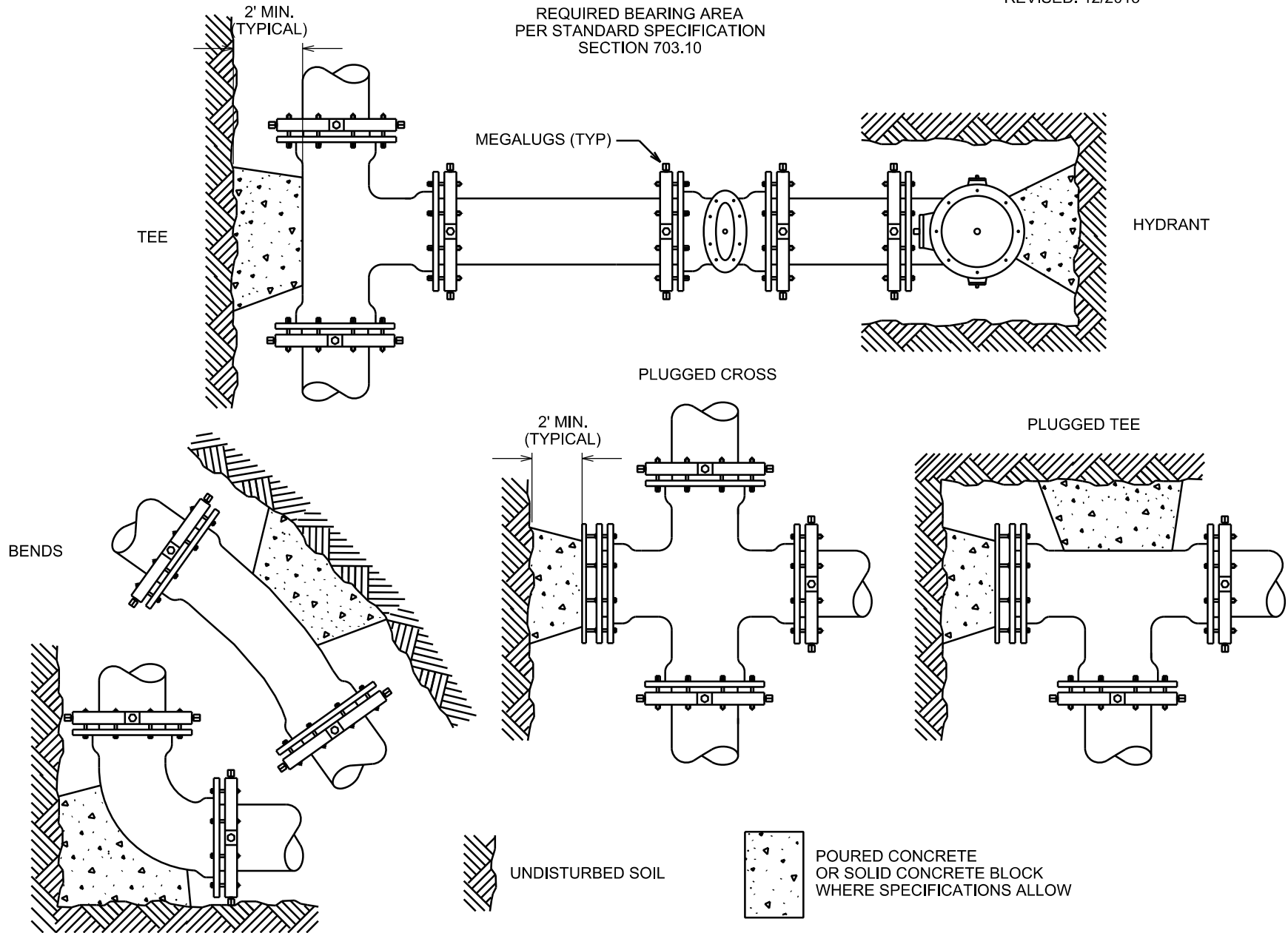

CITY OF MADISON  
WATER UTILITY

NOT TO SCALE

STANDARD CONCRETE BLOCK  
THRUST RESTRAINT

VOLUME REQUIREMENT FOR VERTICAL DOWN BENDS (C.Y.)				
FITTING SIZE (IN)	90° BEND	45° BEND	22.5° BEND	11.25° BEND
4	0.7	0.5	0.3	0.1
6	1.6	1.1	0.6	0.3
8	2.8	2.0	1.1	0.6
10	4.4	3.1	1.7	0.9
12	6.4	4.5	2.4	1.2
16	11.3	8.0	4.3	2.2
20	17.7 3 BARS	12.5 3 BARS	6.8	3.4
24	25.4 6 BARS	18.0 4 BARS	9.7	5.0

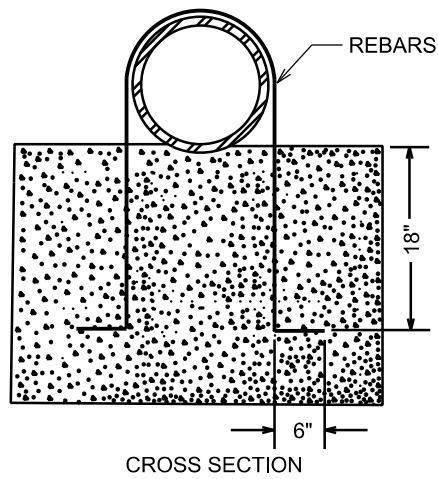
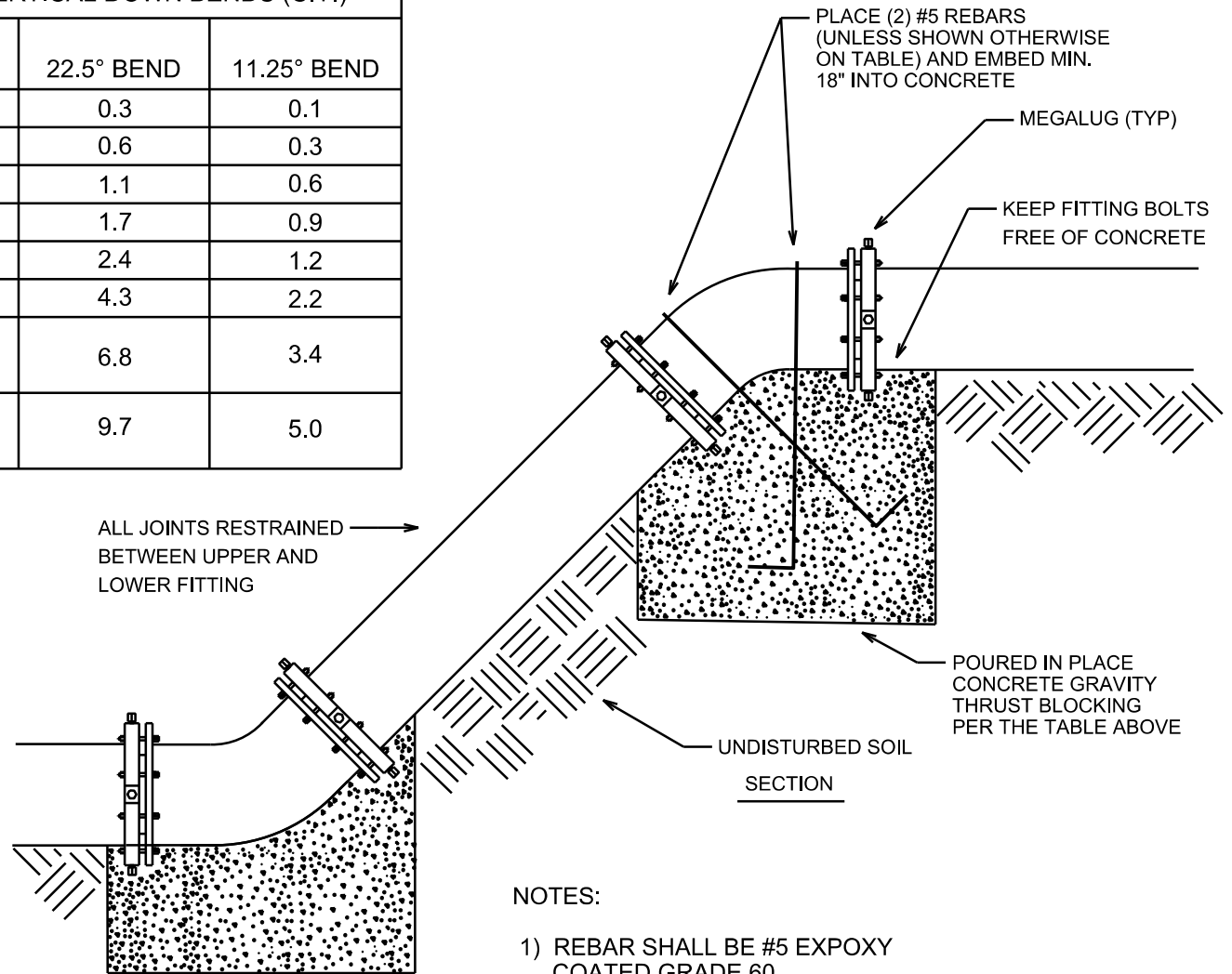

POURED IN PLACE CONCRETE  
THRUST BLOCKING PER  
HORIZONTAL RESTRAINT  
REQUIREMENTS

NOTES:

- 1) REBAR SHALL BE #5 EXPOXY COATED GRADE 60
- 2) CONCRETE SHALL BE MIN. 3,000 PSI COMPRESSIVE STRENGTH
- 3) ABOVE VALUES ARE BASED ON 150 PSI TEST PRESSURE FOR OTHER TEST PRESSURES PROPORTION AS FOLLOWS:  
BLOCK VOLUME=TEST PRESSURE/150 X TABLE VALUE

CITY OF MADISON  
WATER UTILITY

NOT TO SCALE

GRAVITY BLOCK THRUST RESTRAINT  
FOR VERTICAL BENDS

## SECTION 22 19 23

## VALVES

## PART 1 - GENERAL

## 1.1 SUMMARY

- A. Provide valves as shown on the Drawings, as specified herein, and as needed for a complete and proper installation.
- B. Related work:
  - 1. Documents affecting work under this Section include, but are not necessarily limited to, General Conditions, Supplementary Conditions, and Division 01 – General Requirements of these Specifications.
  - 2. Valves furnished as part of factory-fabricated equipment are specified as part of equipment assembly in other sections.
- C. References:
  - 1. Reserved.

## 1.2 SUBMITTALS

- A. Shop Drawing Submittals:
  - 1. General dimensions, construction details, and manufacturer's specifications.
- B. Operation and Maintenance Manuals – Submit operation and maintenance manuals in compliance with pertinent provisions of Section 01 78 26.
- C. Certificates and Guarantees – None Required.
- D. Lubricants – None Required.
- E. Spare Parts – None Required.

## 1.3 QUALITY ASSURANCE

- A. Provide valves of same type by same manufacturer to greatest extent possible.
- B. Provide valves with manufacturer's name and pressure rating clearly marked on valve body.
- C. Ensure all brass and bronze alloys contain less than 15 percent zinc, unless otherwise specified.
  - 1. Brass that will come in contact with potable water shall contain no more than 0.25% lead.
    - a. Brass fittings shall be marked with industry standard marking to indicate the amount of lead (no lead, low lead, etc.) in the brass.

## VALVES

1.4 DELIVERY, STORAGE, AND HANDLING

- A. Comply with pertinent provisions of Section 01 66 11.

1.5 SITE CONDITIONS – Reserved.

1.6 MAINTENANCE – Reserved.

PART 2 - PRODUCTS

2.1 GATE VALVES

- A. Gate valves smaller than 3-inch size:
  - 1. Provide bronze body, wedge disc, screwed bonnet, non-rising stem, threaded-end type with handwheel.
  - 2. Valves designed for 300-pound non-shock W.O.G.
- B. Gate valves 3-inch to 20-inch size:
  - 1. Design in accordance with AWWA C509 (cast iron body), or AWWA C515 (ductile iron body), bronze fitted, resilient wedge disc and seat type with non-rising stem and O-ring seals.
    - a. Provide gear operator for valves 14-inch and larger.
  - 2. Provide ANSI Class 125 standard flange ends and cast iron handwheel for valves to be installed in flanged piping.
    - a. Provide chain wheels, chain guards, and galvanized chains for valves located higher than 6'-6" above the floor level.
  - 3. Provide mechanical joint or push-on joint ends for valves to be installed in underground piping.
- C. Open all gate valves by turning in counterclockwise direction.

2.2 BUTTERFLY VALVES

- A. General:
  - 1. Provide resilient seated type designed for a minimum water working pressure of 150 psi and a maximum temperature rating of 180 degrees F.
  - 2. Design to meet or exceed AWWA C504 for pressure Class 150B.
  - 3. Valve body of one piece cast iron.
  - 4. Valve shafts of 18-8 Type 304 stainless steel and one-piece design.
  - 5. Valve discs of Ni-Resist cast iron alloy, or ductile iron, or ASTM A48, Class 40 cast iron attached to the shaft with solid stainless steel pins or equal, to prevent slippage or misalignment.
  - 6. Valve shaft seals designed for the use of split-V type packing, for O-ring seals or for a pull-down packing.
    - a. Design seals to be replaceable without dismantling the valve.
  - 7. Corrosion resistant, self-lubricating valve shaft bearings.

8. Rubber valve seats designed to provide tight shutoff with 150 psi upstream pressure and zero psi downstream pressure.
- B. Butterfly valves installed in non-submerged flanged piping:
    1. ANSI Class 125 standard flange.
    2. Manual crank or handwheel operated enclosed mechanical type actuator for operation with maximum of 40 pounds of force for valves 10-inch size and smaller and 50 pounds of force for valves 12-inch size or larger unless otherwise shown on the Drawings.
      - a. Rotate gear operator as required to prevent oil leakage.
    3. Chainwheels, chain guides, and galvanized chain for valves with manual operators located higher than 6'-6" above the floor level.
  - C. Butterfly valves installed in underground piping:
    1. Mechanical joint ends.
  - D. Provide fully enclosed manual operators for submerged or underground valves, gasketed, grease lubricated, and sealed for the life of the valve.
    1. Stainless steel exposed nuts, bolts, springs, and washers.
  - E. Acceptable manufacturers:
    1. DeZurik.
    2. Pratt.
    3. Val-Matic Valve.
    4. Or equal.

### 2.3 PVC VALVES

- A. General:
  1. Manufacture PVC valves of Type 1, Grade 1 polyvinyl chloride thermoplastic conforming to the latest revised specification requirements of ASTM D1784.
  2. Provide socket type, threaded type, or ANSI Class 150 standard flange type valve ends.
- B. Ball valves:
  1. True union design with two-way blocking capability.
  2. One-piece capsule feature, or threaded in seal carrier, or other positive means to prevent over-tightening seating components.
  3. Teflon seat and Viton O-ring seals.
- C. Check valves:
  1. True union design ball check valves.
  2. Viton seat and O-ring seals.
- D. Acceptable manufacturers:
  1. Asahi/America.
  2. Hayward Manufacturing Co., Inc.



3. Nibco.
4. Or equal.

## 2.4 HOSE VALVES

- A. Provide compression type valves with brass or bronze body, bonnet, stem and disc holder, rubber composition disc, removable wheel or tee handle, and 3/4-inch standard garden hose thread outlet connection.
  1. 3/8-inch steel or brass operating rod and black steel or copper tube casing on frost-proof valves.
  2. Equip each hose valve with a vacuum breaker similar to Watts No. 8A, or equal.

## 2.5 SAMPLING FAUCET

- A. Provide smooth nose sampling faucet consisting of 1/4-inch diameter copper pipe of 4-inch length (downturned 90 degrees) suitable for bacteriological sampling and flaming connected to a 1/2-inch pipe inlet connection with isolation valve and levered handle. Terminate over a 4-inch PVC pipe funnel drain with 1-inch PVC piping to floor drain.

## 2.6 ALTITUDE VALVE FOR COMPOSITE TANK

- A. Provide a (two-way) flow, hydraulically-operated, globe-type valve with pilot control designed to limit the high water level in an elevated storage tank (and to allow flow to return to the system during higher demand).
  1. Valve body: Ductile iron, ASTM A536 with ANSI B16.1, Class 125 end flanges and ASTM A536 ductile iron cover, with stainless steel trim.
  2. Valve disc: Buna-N synthetic rubber compound.
    - a. Rectangular cross-section.
    - b. Retained on three and one-half sides.
  3. Disc guide: Contoured type for smooth transition of flow.
  4. Diaphragm assembly:
    - a. Diaphragm: Flexible Buna-N synthetic rubber compound, reinforced and fully-supported.
    - b. Equip with two-piece stainless steel stem of sufficient diameter to withstand hydraulic pressure.
    - c. Drill and tap stem in cover end for accessory attachment.
    - d. Stem assembly: Fully supported in three locations with a bearing in the valve cover, a bearing in the power unit body, and an integral bearing in the valve seat.
  5. Valve seat: Removable insert type.
  6. Fusion bonded epoxy interior and exterior.
- B. Provide altitude valve with:
  1. Diaphragm-actuated, 3-way type pilot control system.
    - a. Operates on the differential force between the height of the water in the reservoir and an adjustable spring-load.

- b. Adjustment range: 110 to 160 ft.
  - c. Material: Cast brass, ASTM B62, with Type 303 stainless steel trim and monel.
  - d. Equip with external wye-type strainer and isolation valves.
2. A pilot system so that no surface water can be drawn into the pilot or main valve at any time.
  3. Pilot isolation cocks and sensing line back to tank riser pipe above valve.
  4. A 24 volt single limit switch (X105LCW), with valve position indication back to SCADA.
  5. Cla Val RGT Reservoir Gauge with Tester on pilot system, including pressure gauge.
  6. Dry drain provisions.
- C. Acceptable manufacturers:
1. Cla-Val 210-16BYCHPRKCX105LCW (two-way). Local representative is Dorner Company, Mike Barreau 262-932-2100, ext. 120.
  2. Or equal.

## 2.7 ALTITUDE VALVE FOR ELEVATED TANK (ET 126) AT WELL 26

- A. Provide a (one-way) flow, hydraulically-operated, globe-type valve with pilot control designed to limit the high water level in an elevated storage tank.
1. Valve body: Ductile iron, ASTM A536 with ANSI B16.1, Class 125 end flanges and ASTM A536 ductile iron cover, with stainless steel trim.
  2. Valve disc: Buna-N synthetic rubber compound.
    - a. Rectangular cross-section.
    - b. Retained on three and one-half sides.
  3. Disc guide: Contoured type for smooth transition of flow.
  4. Diaphragm assembly:
    - a. Diaphragm: Flexible Buna-N synthetic rubber compound, reinforced and fully-supported.
    - b. Equip with two-piece stainless steel stem of sufficient diameter to withstand hydraulic pressure.
    - c. Drill and tap stem in cover end for accessory attachment.
    - d. Stem assembly: Fully supported in three locations with a bearing in the valve cover, a bearing in the power unit body, and an integral bearing in the valve seat.
  5. Valve seat: Removable insert type.
  6. Fusion bonded epoxy interior and exterior.
- B. Provide altitude valve with:
1. Diaphragm-actuated, 3-way type pilot control system.
    - a. Operates on the differential force between the height of the water in the reservoir and an adjustable spring-load.
    - b. Adjustment range: 110 to 160 ft.
    - c. Material: Cast brass, ASTM B62, with Type 303 stainless steel trim and monel.
    - d. Equip with external wye-type strainer and isolation valves.

2. A pilot system so that no surface water can be drawn into the pilot or main valve at any time.
  3. Pilot isolation cocks and sensing line back to tank riser pipe above valve.
  4. A 24 volt single limit switch (X105LCW), with valve position indication back to SCADA.
  5. Cla Val RGT Reservoir Gauge with Tester on pilot system, including pressure gauge.
  6. Dry drain provisions.
- C. Acceptable manufacturers:
1. Cla-Val 210-01BYCHPRKCX105LCW (one-way). Local representative is Dorner Company, Mike Barreau 262-932-2100, ext. 120.
  2. Or equal.

## 2.8 BALL VALVES

- A. Brass ball valves:
1. Provide 2-inch and smaller, 2-way, ball valves for use with 2-inch and smaller tube and piping systems.
    - a. Body: Brass.
    - b. Ball stem, packing washers, seat retainers, and ball retainers: Brass.
    - c. Port adapters, packing nut: Brass.
    - d. Handle: Nylon.
    - e. Ball seat: Teflon.
    - f. Adapter and retainer seals: Teflon.
- B. Stainless steel ball valves:
1. Provide Victaulic Series 569, Vic-Press 316 Type 316 stainless steel ball valves.

## 2.9 PAINTING

- A. Comply with the pertinent provisions of Section 09 90 00.

## PART 3 - EXECUTION

- 3.1 Install valves in accordance with manufacturer's recommendations.

END OF SECTION

## SECTION 22 19 26

### GAUGES

#### PART 1 - GENERAL

##### 1.1 SUMMARY

- A. Provide gauges as shown on the Drawings, as specified herein, and as needed for a complete and proper installation.
- B. Related work:
  - 1. Documents affecting work of this Section include, but are not necessarily limited to, General Conditions, Supplementary Conditions, and Division 01 - General Requirements of these Specifications.
  - 2. Gauges furnished as part of factory fabricated equipment are specified as part of equipment assembly in other sections.
  - 3. Refer to Division 22 piping systems sections for specific gauge applications.
- C. References:
  - 1. Reserved.

##### 1.2 SUBMITTALS

- A. Shop Drawing Submittals:
  - 1. General dimensions and manufacturer's specifications.
- B. Operation and Maintenance Manuals – None Required.
- C. Certificates and Guarantees – None Required.
- D. Lubricants – None Required.
- E. Spare Parts – None Required.

##### 1.3 QUALITY ASSURANCE – Reserved.

##### 1.4 DELIVERY, STORAGE, AND HANDLING

- A. Comply with pertinent provisions of Section 01 66 11.

##### 1.5 SITE CONDITIONS – Reserved.

##### 1.6 MAINTENANCE – Reserved.

## PART 2 - PRODUCTS

### 2.1 GENERAL

- A. Provide gauges with ranges shown on the Drawings or specified under Division 22 piping systems.

### 2.2 BOURDON TUBE TYPE PRESSURE GAUGES

- A. Provide phosphor bronze tube, brass socket, 4½-inch aluminum alloy case, white dial, and plastic glass lens.
  - 1. Provide 1/4-inch gauge cock and stainless steel cartridge snubber.
- B. Provide ACCO Helicoid Type 410, or H.O. Trerice Company 500X, or equal.
- C. Provide one (1) for Water System Pressure Transmitter at 0 to 100 psi.
- D. Provide one (1) for Inlet Riser piping at 0 to 100 psi.

## PART 3 - EXECUTION

- 3.1 Install gauges and accessories in accordance with manufacturer's recommendations.

END OF SECTION

SECTION 22 19 33

PIPE INSULATION

PART 1 - GENERAL

1.1 SUMMARY

- A. Provide pipe insulation as shown on the Drawings, as specified herein, and as needed for a complete and proper installation.
- B. Related work:
  - 1. Documents affecting work under this Section include, but are not necessarily limited to, General Conditions, Supplementary Conditions, and Division 01 - General Requirements of these Specifications.
- C. References:
  - 1. Reserved.

1.2 SUBMITTALS

- A. Shop Drawing Submittals:
  - 1. Manufacturer's specifications and other data needed to assure compliance with specified requirements.
  - 2. Manufacturers' recommended installation procedures.
- B. Operation and Maintenance Manuals – None Required.
- C. Certificates and Guarantees – None Required.
- D. Lubricants – None Required.
- E. Spare Parts – None Required.
- F. Comply with pertinent provisions of Section 01 33 01.

1.3 QUALITY ASSURANCE – Reserved.

1.4 DELIVERY, STORAGE, AND HANDLING

- A. Comply with pertinent provisions of Section 01 66 11.

1.5 SITE CONDITIONS – Reserved.

1.6 MAINTENANCE – Reserved.

## PART 2 - PRODUCTS

### 2.1 PIPE INSULATION

- A. Provide pipe insulation on exposed cold water piping with the following features:
  - 1. Flame-attenuated fiberglass bonded with thermosetting resin.
  - 2. Service temperature: 850 degrees F maximum.
  - 3. All-service vapor barrier jacket.
    - a. Reinforced white kraft bonded to aluminum foil.
    - b. Factory-applied double pressure-sensitive adhesive system with matching pressure-sensitive butt strips.
  - 4. Exterior piping: Protect pipe insulation with 0.016-inch smooth or corrugated aluminum jacketing with factory-applied galvanic action barrier and 3/4-inch wide bands.
  - 5. Minimum thickness:
    - a. Pipe sizes 2-inch and smaller: 1-inch.
- B. Provide saddle spreaders between jacketed pipe insulation and pipe supports.
- C. Acceptable products:
  - 1. Manville Micro-Lok.
  - 2. Owens-Corning Fiberglass ASJ-SSL-II.
  - 3. Or equal.

## PART 3 - EXECUTION

### 3.1 INSTALLATION

- A. Install over clean, dry surfaces and in strict accordance with the manufacturer's recommended installation procedures.

END OF SECTION

## SECTION 22 19 43

### PLUMBING AND FIXTURES

#### PART 1 - GENERAL

##### 1.1 SUMMARY

- A. Provide plumbing as shown on the Drawings, as specified herein, and as needed for a complete and proper installation including, but not necessarily limited to:
  - 1. Building hot and cold water piping systems.
  - 2. Drain, waste, and vent systems.
  - 3. Plumbing fixtures and trim.
- B. Related work:
  - 1. Documents affecting work of this Section include, but are not necessarily limited to, General Conditions, Supplementary Conditions, and Division 01 - General Requirements of these Specifications.
- C. References:
  - 1. Reserved.

##### 1.2 SUBMITTALS

- A. Shop Drawing Submittals:
  - 1. Manufacturer's specification catalog cuts for water heaters.
- B. Operation and Maintenance Manuals: Submit operation and maintenance manuals in compliance with pertinent provisions of Section 01 78 26.
- C. Certificates and Guarantees – None Required.
- D. Lubricants – None Required.
- E. Spare Parts – None Required.
- F. Comply with pertinent provisions of Section 01 33 01.

##### 1.3 QUALITY ASSURANCE

- A. Use adequate numbers of skilled workmen who are thoroughly trained and experienced in the necessary crafts and who are completely familiar with the specified requirements and the methods needed for proper performance of the work of this Section.
- B. Codes and regulations:
  - 1. In addition to complying with the specified requirements, comply with pertinent regulations of governmental agencies having jurisdiction.
  - 2. In the event of conflict between or among specified requirements and pertinent regulations, the more stringent requirement will govern when so directed by the Engineer.



1.4 DELIVERY, STORAGE, AND HANDLING

- A. Comply with pertinent provisions of Section 01 66 11.

1.5 SITE CONDITIONS – Reserved.

1.6 MAINTENANCE – Reserved.

PART 2 - PRODUCTS

2.1 PIPE SCHEDULE

- A. Drain, waste, and vent system:
  - 1. For sanitary work below the floor and outside underground:
    - a. Provide cast iron soil pipe and fittings unless otherwise shown on the Drawings.
  - 2. For inside building:
    - a. Provide cast iron soil pipe and fittings or plastic drainage pipe and fittings unless otherwise shown on the Drawings.
- B. Potable water system (cold water piping): as shown on the Drawings.
  - 1. Inside building:
    - a. Tempered and cold water piping: Provide insulation for exposed water piping.

2.2 PIPE AND FITTING MATERIALS

- A. Comply with Section 22 19 13.

2.3 VALVES

- A. Comply with Section 22 19 23.

2.4 FIXTURES

- A. Floor drains:
  - 1. Provide cast iron standard 3-inch spigot outlet type, 9-inch x 9-inch top size with loose strainer, Tyler Series 300-TY, or equal.

PART 3 - EXECUTION

3.1 SURFACE CONDITIONS

- A. Examine the areas and conditions under which work of this Section will be performed. Correct conditions detrimental to timely and proper completion of the Work. Do not proceed until unsatisfactory conditions are corrected.

### 3.2 PLUMBING SYSTEM LAYOUT

- A. Lay out the plumbing system in careful coordination with the Drawings, determining proper elevations for all components of the system and using only the minimum number of bends to produce a satisfactorily functioning system.
- B. Follow the general layout shown on the Drawings in all cases except where other work may interfere.
- C. Lay out pipes to fall within partition, wall, or roof cavities, and to not require furring other than as shown on the Drawings.

### 3.3 INSTALLATION OF PIPING AND EQUIPMENT

- A. General:
  - 1. Comply with Section 22 19 13 for pipe installation, support, testing, and/or disinfection.
  - 2. Thoroughly clean items before installation. Cap pipe openings to exclude dirt until fixtures are installed and final connections have been made.
  - 3. Run horizontal sanitary and storm drainage piping at a uniform grade of 1/4-inch per foot, unless otherwise noted. Run horizontal water piping with an adequate pitch upwards in direction of flow to allow complete drainage.
  - 4. Pipe the drains from pump glands, drip pans, relief valves, air vents, and similar locations, to spill over an open sight drain, floor drain, or other acceptable discharge point, and terminate with a plain end unthreaded pipe 6 inches above the drain.
  - 5. Securely bolt all equipment, isolators, hangers, and similar items in place.
  - 6. Support each item independently from other pipes. Do not use wire for hanging or strapping pipes.
  - 7. Provide complete dielectric isolation between ferrous and non-ferrous metals.
  - 8. Provide union and shut off valves suitably located to facilitate maintenance and removal of equipment and apparatus.
  - 9. Install 1/4-inch bronze cock with 1/4-inch copper tubing return manual air vents at the high points of all pipelines carrying water of any service class which cannot be vented through service connections or vent cocks provided with equipment.
- B. Equipment access:
  - 1. Install piping, equipment, and accessories to permit access for maintenance. Relocate items as necessary to provide such access, and without additional cost to the Owner.
  - 2. Provide access doors where valves, motors, or equipment requiring access for maintenance are located in walls or chases or above ceilings. Coordinate location of access doors with other trades as required.

### 3.4 CLEANOUTS

- A. Secure the Engineer's approval of locations for cleanouts in finished areas prior to installation.

- B. Provide cleanouts of same nominal size as the pipes they serve; except where cleanouts are required in pipes 4-inch and larger provide 4-inch cleanouts.
- C. Make cleanouts accessible. After pressure tests are made and approved, thoroughly graphite the cleanout threads.

### 3.5 VALVES

- A. Locate and arrange so as to give complete regulation of apparatus, equipment and fixtures.
- B. Provide valves in at least the following locations:
  - 1. In branches and/or headers of water piping serving a group of fixtures.
  - 2. On both sides of apparatus and equipment.
  - 3. For shutoff of risers and branch mains.
  - 4. For flushing and sterilizing the system.
  - 5. Where shown on the Drawings.
- C. Locate valves for easy accessibility and maintenance.

### 3.6 PLUMBING FIXTURE INSTALLATION

- A. Installation:
  - 1. Set fixtures level and in proper alignment with respect to walls and floors, and with fixtures equally spaced.
  - 2. Provide supplies in proper alignment with fixtures and with each other.
  - 3. Provide flush valves in alignment with the fixture, without vertical or horizontal offsets.
- B. Grout wall and floor mounted fixtures watertight where the fixtures are in contact with walls and floors.
- C. Caulk deck-mounted trim at the time of assembly, including fixture and casework mounted. Caulk self-rimming sinks installed in casework.

### 3.7 OTHER TESTING AND ADJUSTING

- A. Provide personnel and equipment, and arrange for and pay the costs of, all required tests and inspections required by governmental agencies having jurisdiction.
- B. Where tests show materials or workmanship to be deficient, replace or repair as necessary, and repeat the tests until the specified standards are achieved.
- C. Adjust the system to optimum standards of operation.

END OF SECTION

## SECTION 23 00 00

## HEATING, VENTILATING, AND AIR CONDITIONING (HVAC)

## PART 1 - GENERAL

## 1.1 SUMMARY

- A. Provide heating, ventilating, and air conditioning systems as shown on the Drawings, as specified herein, and as needed for a complete and proper installation.
- B. Related work:
  - 1. Documents affecting work under this Section include, but are not necessarily limited to, General Conditions, Supplementary Conditions and Division 01 - General Requirements of these Specifications.
- C. References:
  - 1. Reserved.

## 1.2 SUBMITTALS

- A. Shop Drawing Submittals:
  - 1. Design drawings, signed by a registered engineer and showing proposed layout of equipment, ducts, registers, grilles, controls, and other components of the system.
  - 2. Calculations demonstrating the adequacy of the proposed systems and its compliance with these Specifications.
  - 3. Manufacturers' catalogs and other items needed to fully demonstrate the quality of the proposed materials and equipment.
- B. Operation and Maintenance Manuals – Submit operation and maintenance manuals in compliance with pertinent provisions of Section 01 78 26.
- C. Certificates and Guarantees – None Required.
- D. Lubricants – None Required.
- E. Spare Parts – None Required.
- F. Comply with pertinent provisions of Section 01 33 01.
- G. Submit Testing, Adjusting and Balancing report specified in Part 3.

## 1.3 QUALITY ASSURANCE

- A. Without additional cost to the Owner, provide such other labor and materials as are required to complete the work of this Section in accordance with the requirements of

## HEATING, VENTILATING, AND AIR CONDITIONING (HVAC)

23 00 00-1 (150826.40)

governmental agencies having jurisdiction, regardless of whether such materials and associated labor are called for elsewhere in these Contract Documents.

#### 1.4 DELIVERY, STORAGE, AND HANDLING

- A. Comply with pertinent provisions of Section 01 66 11.

#### 1.5 SITE CONDITIONS – Reserved.

#### 1.6 MAINTENANCE – Reserved.

### PART 2 - PRODUCTS

#### 2.1 VENTILATING FANS

A. General:

1. Provide ventilating fans of the type and capacity as shown on the Drawings and specified herein.
2. Unless otherwise specified, provide fans for operation on 120 volt, single phase, 60 Hertz alternating current power supply.
3. Provide polarized safety disconnect plug or safety disconnect switch as part of unit, except for propeller type wall exhaust fans.

B. Wall fans (propeller type):

1. Provide fresh air inlet fan, motorized damper and louver with appurtenances as noted in this Section and Section 33 16 19.33.

C. Washroom exhaust fan:

1. Provide centrifugal type, direct driven, complete with heavy-duty steel housing, life-time lubricated motor, ceiling grille, backdraft damper, wall or roof cap as shown on the Drawings, and solid state speed control switch.
2. Acceptable manufacturers: Penn Zephyr Z5, or ACME Model V100, or equal.
3. Connect exhaust with aluminum duct work and provide 45 degree angled hood outlet on exterior of tank, with color selected by Owner.

#### 2.2 MOTORIZED DAMPERS

A. Provide insulated, AMCA-rated, low leakage, extruded aluminum control dampers with parallel blades for 2-position control and the following:

1. Frames: Minimum 0.125-inch thick, 5-inch x 1-inch extruded 6063T5 aluminum channel frames with reinforced corners; thermally broken with dual polyurethane resin filled gaps.
2. Blades: Heavy gage extruded 6063T5 aluminum, airfoil shaped damper blades; each blade internally insulated with polyurethane foam and thermally broken between inner and outer skins.
3. Blade Axles: Blades shall be secured to 1/2-inch diameter, 304 stainless steel axles and hardware.

### HEATING, VENTILATING, AND AIR CONDITIONING (HVAC)

23 00 00-2 (150826.40)

4. Bearings: Non-corrosive dual bearing with molded synthetic inner sleeve and flanged outer bearings.
5. Linkage: 304 stainless steel blade-to-blade side linkage, out of airstream, concealed in frame.
6. Control Shafts: For duct mounted applications, provide minimum 6-inch long, ½-inch diameter, 304 stainless steel removable control shaft with support bearing on side of damper.
7. Jackshaft Systems: For multiple section dampers, provide factory installed 1-inch diameter jackshaft systems with support bearings and required linkages.
8. Crank Arm Systems: For wall louver applications, provide factory installed blade crank arms, controls shafts, and actuators. Provide factory installed linkages and actuator supports suitable for damper installation within wall openings and actuator installation in the damper airstream or adjacent to wall opening with actuator as high as possible above floor and in locations to minimize hazards to building occupants.
9. Blade Seals: Synthetic resilient jamb seals and blade edge seals.
10. Leakage Rating: AMCA certified for no greater than 3 cfm/sq.ft. leakage at 1 inwc. pressure differential when tested according to AMCA 500D.
11. Thermal Performance: Minimum 0.549 (sf-deg F)/Btuh damper assembly thermal resistance rating (R-value), when tested per ASTM C1363/C976.

B. Acceptable products: Subject to compliance with requirements, provide one of the following motorized dampers:

1. Greenheck, Model ICD-45.
2. No substitutions.

### 2.3 MOTORIZED DAMPER ACTUATORS

A. Provide UL listed, double insulated, actuators; direct-coupled type, designed for direct mounting to damper control shafts or jackshafts without crank arms or linkages.

1. Torque: Provide actuators in quantities and sizes for running torques sufficient to operate dampers with sufficient reserve power to provide smooth 2-position action.
2. Motor: Brushless DC motor, monitored and controlled by integrated circuit with rotation sensing to prevent damage or overload due to stall conditions at all angles of rotation.
3. Housing: Constructed of zinc coated steel, NEMA type 2.
4. Coupling: V-bolt and V-shaped, toothed cradle suitable for shafts with 1.05-inch diameter or less.
5. Direction of Rotation: Reversible; clockwise or counterclockwise with visual position indicator.
6. Manual Override: Manual positioning mechanism accessible on cover.
7. Overload Protection: Electronic overload or digital rotation-sensing circuitry.
8. Fail-Safe Operation: Mechanical, spring-return mechanism.
9. Auxiliary Switches: Two UL listed SPDT switches, one fixed and one adjustable.
10. Power Requirements (Two-Position, Spring Return): 120 VAC, 60 Hz.
11. Temperature Rating: Minus 22 to plus 122 deg F.

12. Run Time: 15 seconds maximum on powered stroke, independent of torque; less than 15 seconds spring return.
  13. Acceptable manufacturers: Subject to compliance with requirements, provide damper actuators by one of the following manufacturers:
    - a. Honeywell model MS4120F-1204.
    - b. No substitutions.
- B. Damper Fail-Safe Positions: Provide actuators with the following fail-safe positions on power failure or loss of signal:
1. Unless noted otherwise: Spring Return Closed.
- C. Hardware: Provide factory-supplied brackets, bearings, control rods, crank arms, ball joints, and any other hardware required for actuator installation and function.

## 2.4 DEHUMIDIFIERS

- A. Commercial grade, high efficiency, refrigeration type:
1. Low temperature, self-contained unit complete with humidistat, blower switch that permits continuous blower operation, four casters for complete portability, internal condensate pump, wiring with 115V grounded plug, and plastic drain hose.
  2. Capacity:
    - a. Moisture removal: 106 pints per day at 80 degrees F and 60 percent relative humidity.
  3. Voltage: 120 volts, single phase, 60 Hz AC.
  4. Acceptable products:
    - a. Hi-E Dry Model 100.

## PART 3 - EXECUTION

### 3.1 COORDINATION

- A. Coordinate as required with other trades to assure proper and adequate provision in the work of those trades for interface with the work of this Section.

### 3.2 PREPARATION

- A. Holes in concrete:
1. Provide sleeves, accurately dimensioned and shaped to permit passage of items of this Section.
  2. Deliver all such sleeves, with accurate setting drawings and setting information, to the trades providing the surfaces through which such items must penetrate, and in a timely manner to assure inclusion in the Work.
- B. Flashing:
1. Where items of this Section penetrate the roof, outer walls, or waterproofing of any kind, provide under this Section all base flashing and counterflashing required at such penetration.
  2. Provide on each pipe passing through the roof a 3 lb. seamless lead flashing and counterflashing assembly.

### 3.3 EQUIPMENT INTERFACE

- A. Provide all required shutoff valves, unions, and final connections of piping to the work of this Section.
- B. For electrically operated equipment, verify the electrical characteristics actually available for the work of this Section and provide equipment meeting those characteristics.

### 3.4 PAINTING

- A. For equipment, provide factory prefinish on all exposed surfaces.
- B. Touch up scratches and abrasions to be invisible to the unaided eye from a distance of 5'-0".

### 3.5 INSTRUCTIONS

- A. Upon completion of this portion of the Work, and prior to its acceptance by the Owner, provide a qualified engineer and fully instruct the Owner's maintenance personnel in the proper operation and maintenance of items provided under this Section.
- B. Demonstrate the contents of the approved operation and maintenance manual required under Article 1.2 above.

### 3.6 TESTING AND ADJUSTING

- A. Test and adjust each piece of equipment and each system as required to assure proper balance and operation.
  - 1. Test and regulate ventilation and air conditioning systems to conform to the air volumes shown on the approved design drawings.
  - 2. Make tests and adjustments in apparatus and ducts for securing the proper volume and face distribution of air for each grille and ceiling outlet.
  - 3. For each system, record the following data in tabulated form:
    - a. Air volumes at all supply, return, and exhaust outlets.
    - b. Total cfm supplied.
    - c. Total cfm returned.
    - d. Total static pressure at each fan and at each system.
    - e. Room pressure in inches of water column for each room
    - f. Motor speed, fan speed, and input ampere rating for each fan.
- B. Submit two sets of test and balance reports to the Engineer for approval.
- C. Eliminate noise and vibration, and assure proper function of all controls, maintenance of temperature, and operation in accordance with the approved design.

END OF SECTION



## SECTION 23 37 13

### DIFFUSERS, REGISTERS, AND GRILLES

#### PART 1 - GENERAL

##### 1.1 SUMMARY

- A. Provide diffusers, registers and grilles as shown on the Drawings, as specified herein, and as needed for a complete and proper installation.
- B. Related work:
  - 1. Documents affecting work of this Section include, but are not necessarily limited to, General Conditions, Supplementary Conditions, and Division 01 - General Requirements of these Specifications.
- C. References:
  - 1. Reserved.

##### 1.2 SUBMITTALS

- A. Shop Drawing Submittals:
  - 1. Product Data: Indicate materials of construction, finish, and mounting details for each furnished item.
  - 2. Schedule: Indicate drawing designation, room location, quantity, model number, size, and accessories furnished for each diffuser, register, and grille.
  - 3. Performance Data: Include throw and drop, static-pressure drop, and noise ratings for each furnished item.
  - 4. Testing, Adjusting, and Balancing Data: Provide TAB instructions and balancing factors for each furnished item.
- B. Operation and Maintenance Manuals – None Required.
- C. Certificates and Guarantees – None Required.
- D. Lubricants – None Required.
- E. Spare Parts – None Required.
- F. Comply with pertinent provisions of Section 01 33 01.

##### 1.3 QUALITY ASSURANCE – Reserved.

##### 1.4 DELIVERY, STORAGE, AND HANDLING

- A. Comply with pertinent provisions of Section 01 66 11.

1.5 SITE CONDITIONS – Reserved.

1.6 MAINTENANCE – Reserved.

1.7 CLOSEOUT SUBMITTALS

A. Operation and Maintenance Data:

1. Submit data in compliance with Section 01 78 26, Operation and Maintenance Manual requirements.
2. Include operation, balancing, and maintenance manuals.

## PART 2 - PRODUCTS

2.1 GENERAL

- A. Provide metal diffusers, registers, and grilles in the arrangements and dimensions indicated.
- B. Provide blades, frames, and dampers constructed of aluminum or stainless steel; matching the construction of attached ductwork.

2.2 SUPPLY, RETURN, EXHAUST, AND WALL LOUVER APPLICATIONS

A. All Supply Return, Exhaust, and Transfer Applications:

1. Type: Fixed egg crate type.
2. Border: 1¼-inch border with countersunk screw holes.
  - a. Mount with stainless steel screws.
3. Finish: White baked acrylic or polyester finish for ceiling or wall mounted units and mounting screws, unless indicated otherwise.
  - a. Provide mill finish for units and screws mounted to exposed ducts.

## PART 3 - EXECUTION

3.1 INSTALLATION

- A. Coordinate as required with other trades to assure proper and adequate provision in the work of those trades for interface with the work of this Section.
- B. Install the work of this Section in strict accordance with the approved Shop Drawings and the recommendations of the manufacturers as approved by the Engineer, anchoring all components firmly into position in true alignment vertically and horizontally.

END OF SECTION

SECTION 23 85 00  
ELECTRIC HEATERS

PART 1 - GENERAL

1.1 SUMMARY

- A. Provide electric heaters as shown on the Drawings, as specified herein, and as needed for a complete and proper installation.
- B. This section includes the following:
  - 1. Electric unit heaters.
- C. Related work:
  - 1. Documents affecting work under this Section include, but are not necessarily limited to, General Conditions, Supplementary Conditions, and Division 01 - General Requirements of these Specifications.
- D. References:
  - 1. Reserved.

1.2 SUBMITTALS

- A. Shop Drawing Submittals:
  - 1. Enclosure dimensions, nameplate data, electrical ratings, wiring diagrams, and manufacturer's detailed specifications.
- B. Operation and Maintenance Manuals – Submit operation and maintenance manuals in compliance with pertinent provisions of Section 01 78 26.
- C. Certificates and Guarantees – None Required.
- D. Lubricants – None Required.
- E. Spare Parts – None Required.

1.3 QUALITY ASSURANCE

- A. Comply with the following requirements:
  - 1. NFPA 70 National Electrical Code (NEC).
  - 2. Local codes and ordinances.

1.4 DELIVERY, STORAGE, AND HANDLING

- A. Comply with pertinent provisions of Section 01 66 11.

1.5 SITE CONDITIONS – Reserved.

1.6 MAINTENANCE – Reserved.

## PART 2 - PRODUCTS

### 2.1 GENERAL

- A. Provide electric heaters with indicated performance ratings, styles, and accessories. Provide proper mounting hardware for wall mounting.
- B. Provide electric heaters listed by UL.

### 2.2 ELECTRIC UNIT HEATERS

- A. Provide electric unit heaters consisting of casing, heating element, propeller fan, fan motor, controls, and the following:
  - 1. Configurations: Horizontal or vertical discharge, as indicated.
  - 2. Louvers: Individually adjustable louver blades.
    - a. Horizontal blades for horizontal discharge units.
    - b. Radial blades for vertical discharge units.
  - 3. Casings: Steel construction with paint or powder coat finish.
  - 4. Heating elements: Nickel-chromium resistance wire embedded in compacted dielectric within sealed corrosion resistant steel tubes with fins. Enclose ends of element in terminal box.
    - a. Circuit protection.
  - 5. Fans: Direct driven resiliently mounted propeller fans with aluminum blades.
  - 6. Motors: Totally enclosed, rated for continuous duty, same voltage as heating element, with thermal overload protection and permanently lubricated bearings.
  - 7. Controls:
    - a. High temperature safety switch.
    - b. Fan control with time or temperature based start and stop delay functions.
    - c. Unit-mounted thermostat, contractor, and reduced voltage transformer.
  - 8. Electrical characteristics: 208 volt, 3 phase, 60 Hz unless indicated otherwise; factory-wired for single point wiring connection in field.
  - 9. Acceptable products: Provide Chromalox Type KUH, Electromode EU Series, QMark MUH Series, Markel Series 51, or equal.

## PART 3 - EXECUTION

### 3.1 INSTALLATION

- A. Install electric heaters in accordance with manufacturer's recommendations.
  - 1. Mount cabinet unit heaters flush in wall or ceiling as shown on Drawings.

### 3.2 ADJUSTMENT

- A. Adjust and plumb units for proper mounting and installation. Check that air flow is directed properly.
- B. Set thermostat to temperatures as directed by the Owner or Engineer.

END OF SECTION

ELECTRIC HEATERS  
23 85 00-2 (150826.40)

## SECTION 26 05 19

## LOW-VOLTAGE ELECTRICAL POWER CONDUCTORS AND CABLES

## PART 1 - GENERAL

## 1.1 SUMMARY

- A. Provide low-voltage electrical power conductors and cables as shown on the Drawings, as specified herein, and as needed for a complete and proper installation.
- B. Related work:
  - 1. Documents affecting work under this Section include, but are not necessarily limited to, General Conditions, Supplementary Conditions, and Division 01 - General Requirements of these Specifications.
- C. References:
  - 1. Reserved.

## 1.2 SUBMITTALS

- A. Shop Drawing Submittals – None Required.
- B. Operation and Maintenance Manuals – None Required.
- C. Certificates and Guarantees – None Required.
- D. Spare Parts – None Required.

## 1.3 QUALITY ASSURANCE

- A. Comply with the following requirements:
  - 1. NFPA 70 National Electrical Code (NEC).
  - 2. Local codes and ordinances.

## 1.4 DELIVERY, STORAGE, AND HANDLING

- A. Comply with pertinent provisions of Section 01 66 11.

## 1.5 SITE CONDITIONS – Reserved.

## 1.6 MAINTENANCE – Reserved.

## PART 2 - PRODUCTS

### 2.1 GENERAL

- A. Comply with the following standards:
  - 1. UL 83 and ICEA S-61-402 for thermoplastic insulated wire and cable.
  - 2. UL 44, ICEA S-19-81 and ICEA S-66-524 for rubber or rubber-like and cross-linked thermosetting polyethylene insulated wire and cable.
- B. Provide copper wire only.
- C. No underground splices allowed unless approved by the Engineer.

### 2.2 WIRE AND CABLE IN RACEWAY AND CONDUIT

- A. Power, light, and control conductors:
  - 1. Insulation: Rated for 600 volts.
    - a. Use dual rated type THHN/THWN in temperature controlled indoor locations.
    - b. Use Type XHHW in underground locations and unheated concrete structures.
  - 2. Use stranded wire for control conductors.

### 2.3 JOINTS, TAPS, SPLICES, AND TERMINATIONS

- A. Conductors No. 10 AWG and smaller: Use twist type insulated wire nut solderless connectors.
- B. Conductors No. 8 AWG and larger: Use solderless compression type connectors of type that will not loosen under vibration or normal strains.
- C. Control and instrumentation conductors: Use crimp type spade connectors where control wires are connected to screw terminals of equipment.
- D. Joints, taps, and splices located in enclosures subject to moisture: Use watertight splice kits.

### 2.4 PERMANENT WIRE MARKERS

- A. Provide type-on, self-laminating vinyl, heat shrink polyolefin or nylon clip-sleeve, alpha-numeric, permanent wire markers.
  - 1. Use fine-line, black, permanent ink pens where field marking is necessary.
  - 2. Cloth tags are not acceptable.

## PART 3 - EXECUTION

### 3.1 INSTALLATION

- A. Install wiring system in accordance with manufacturer's recommendations.

- B. Install wire and cable in conduit unless otherwise shown on the Drawings.
- C. Trench and backfill for direct burial cables: Comply with Section 31 23 79.
  - 1. Install cable in rigid steel conduit under and 1-foot beyond all driveways and other pavement, and within a radius of 5 feet from all structures, trees, obstacles, etc.
  - 2. Provide suitable bracing for cable to withstand movement due to settlement where cable crosses a previous or new excavation.
  - 3. Seal all conduit entrances with watertight cable-conduit seals to prevent entrance of water into underground structures and caulk opposite end of conduit where conductors enter junction box, panel or electrical enclosure.
- D. Install warning tape along and above direct buried cable.
  - 1. Use red plastic, 6-inch wide tape.
  - 2. Imprinted "CAUTION - ELECTRIC CABLE BELOW".
  - 3. Bury approximately 1-foot below surface before final backfilling.
- E. Maintain barrier or conduit separation between power conductors and instrumentation conductors to avoid magnetic interaction where such conductors enter and pass through same manhole, handhole, casing pipe, box, or enclosure.

### 3.2 WIRE AND CABLE IDENTIFICATION

- A. Install permanent wire markers on wire and cable in junction boxes, pull boxes, wireways, and wiring gutters of panels. Markers to identify wire or cable number.
- B. Provide schedule identifying various power and lighting conductors from power source to equipment or device served.

### 3.3 FIXTURE OUTLETS

- A. Use minimum AWG No. 12 wire for conductors supplying power to single fixture.

END OF SECTION

## SECTION 26 05 23

## CONTROL-VOLTAGE ELECTRICAL POWER CABLES

## PART 1 - GENERAL

## 1.1 SUMMARY

- A. Provide control-voltage wires, cables, and connectors as shown on the Drawings, as specified herein, and as needed for a complete and proper installation.
- B. Related work:
  - 1. Documents affecting work under this Section include, but are not necessarily limited to, General Conditions, Supplementary Conditions, and Division 01 - General Requirements of these Specifications.
- C. References:
  - 1. Reserved.

## 1.2 SUBMITTALS

- A. Shop Drawing Submittals – None Required.
- B. Operation and Maintenance Manuals – None Required.
- C. Certificates and Guarantees – None Required.
- D. Spare Parts – None Required.

## 1.3 QUALITY ASSURANCE

- A. Comply with the following requirements:
  - 1. NFPA 70 National Electrical Code (NEC).
  - 2. Local codes and ordinances.

## 1.4 DELIVERY, STORAGE, AND HANDLING

- A. Comply with pertinent provisions of Section 01 66 11.

## 1.5 SITE CONDITIONS – Reserved.

## 1.6 MAINTENANCE – Reserved.

## PART 2 - PRODUCTS

## 2.1 GENERAL

- A. Comply with the following standards:
  - 1. UL 83 and ICEA S-61-402 for thermoplastic insulated wire and cable.



2. UL 44, ICEA S-19-81 and ICEA S-66-524 for rubber or rubber-like and cross-linked thermosetting polyethylene insulated wire and cable.

B. Provide copper wire only.

## 2.2 WIRE AND CABLE

A. Shielded instrumentation cable:

1. Conductors: Stranded No. 18 AWG tinned copper.
2. Insulation: Polyethylene or fluorinated ethylene propylene (FEP), color coded, rated for 300 volts.
3. Jacket: Polyvinyl chloride or FEP.
4. Shielding: Aluminum polyester, 100 percent coverage.
  - a. Includes stranded No. 20 AWG tinned copper drain wire.
5. Provide Belden, or equal, copper instrumentation cable systems:
  - a. For 2-conductor requirements:
    - (1) Belden No. 8760 suitable for indoor.
    - (2) Belden No. 88760 suitable for outdoor & burial.
  - b. For 3-conductor requirements:
    - (1) Belden No. 8770 suitable for indoor.
    - (2) Belden No. 88770 suitable for outdoor & burial.
  - c. For 2-twisted pair requirements: Belden No. 9552.
6. UL Listed for use.
7. Provide shielded instrumentation cable suitable for flooded burial and freeze/thaw conditions where installed in duct banks, underground conduits, or conduits in and on unheated structures.

B. Multi-conductor shielded instrumentation cable:

1. Conductors: Stranded No. 16 or 18 AWG tinned copper.
2. Insulation: Flame-retardant ethylene propylene rubber (EPR) Type II or cross-linked polyethylene (XLPE). Color code per ICEA Method 1; pair – black & white. One conductor in each pair is printed alpha-numerically for easy identification.
3. Shield: Individual pairs shielded with aluminum/polyester in contact with stranded tinned copper drain wire and overall shielded is aluminum/polyester in contact with stranded tinned copper drain wire.
4. Outer jacket: Flame-retardant thermoplastic chlorinated polyethylene (CPE).
5. Volts: 300V or 600V.
6. Conductors: Class B stranding per ASTM B8, tinned annealed copper per ASTM B33.
7. Application: In free air, raceways or direct burial in accordance with NEC. Permitted for use in Class I Div. 2 industrial hazardous locations per NEC Article 501-4(b) for UL Type PLTC cables.
8. Acceptable manufacturers:
  - a. General Cable.
  - b. Omni Cable.
  - c. Or equal.

- C. Data cables:
1. Verify unique cable requirements of individual data systems shown on Drawings with Systems Integrator.
  2. Provide Belden or equal, copper data cable systems:
    - a. DeviceNet Applications:
      - (1) No. 3083A CPE (Thick).
      - (2) No. 3085A CPE (Thin).
      - (3) No. 3082A PVC (Thick).
      - (4) No. 3084A PVC (Thin).
    - b. ControlNet Applications:
      - (1) No. 3092A RG-6 PVC Quad shield coax suitable for outdoor.
      - (2) No. 3093A RG-6 FEP Quad shield coax, plenum, suitable for outdoor & burial.
    - c. E/IP application:
      - (1) Belden No. 7953A Cat 6 – 4 pair, bonded, indoor rated, stranded, shielded, 600 Volt rated.
      - (2) Belden No. 7937A Cat 5e – 4 pair, bonded, burial rated, stranded, shielded, 300 Volt rated.
    - d. Profibus DP Applications:
      - (1) No. 3079A 22AWG 300V Twinax.
      - (2) No. 3079E 22AWG 300V Twinax, Flex Version.
    - e. Modbus application:
      - (1) No. 8777 22 AWG, 3 pair modem drop cable.
  3. Provide data cable suitable for flooded burial and freeze/thaw conditions where installed in duct banks, underground conduits, or conduits in and on unheated structures.
  4. Provide data cables UL listed for intended use.
  5. Crimped-on “male” connectors are not allowed for E/IP cable terminations. E/IP cables are to be “punched-down” in “key-stone” type jack that is to be supplied by panel manufacturer as specified in other cabinet/panel specifications.
  6. Utilize 600 Volt rated cable inside electrical enclosures that contain more than 300 Volts.

## 2.3 JOINTS, TAPS, SPLICES, AND TERMINATIONS

- A. Conductors No. 10 AWG and smaller: Use twist type insulated wire nut solderless connectors.
- B. Control and instrumentation conductors: Use crimp type spade connectors where control wires are connected to screw terminals of equipment.
- C. Joints, taps, and splices located in enclosures subject to moisture: Use watertight splice kits.

## 2.4 PERMANENT WIRE MARKERS

- A. Provide type-on, self-laminating vinyl, heat shrink polyolefin or nylon clip-sleeve, alpha-numeric, permanent wire markers.
  1. Use fine-line, black, permanent ink pens where field marking is necessary.

2. Cloth tags are not acceptable.

## PART 3 - EXECUTION

### 3.1 INSTALLATION

- A. Install wiring system in accordance with manufacturer's recommendations.
- B. Install wire and cable in conduit unless otherwise shown on the Drawings.
- C. Maintain barrier or conduit separation between power conductors and instrumentation conductors to avoid magnetic interaction where such conductors enter and pass through same manhole, handhole, casing pipe, box, or enclosure.
- D. Run instrumentation conductors into control cabinets or MCC only if terminated therein. Maintain separation of power and instrumentation conductors inside cabinets.
- E. Provide individual wiring compartments or barrier for separation between intrinsically safe and non-intrinsically safe conductors inside enclosures.

### 3.2 WIRE AND CABLE IDENTIFICATION

- A. Install permanent wire markers on wire and cable in junction boxes, pull boxes, wireways, and wiring gutters of panels. Markers to identify wire or cable number.
- B. Provide schedule identifying various control and instrumentation circuit conductors based on equipment tag numbers.

END OF SECTION

## SECTION 26 05 26

## GROUNDING AND BONDING OF ELECTRICAL SYSTEMS

## PART 1 - GENERAL

## 1.1 SUMMARY

- A. Provide grounding and bonding as shown on the Drawings, as specified herein, and as needed for a complete and proper installation.
- B. Related work:
  - 1. Documents affecting work under this Section include, but are not necessarily limited to, General Conditions, Supplementary Conditions, and Division 01 - General Requirements of these Specifications.
- C. References:
  - 1. Reserved.

## 1.2 SUBMITTALS

- A. Shop Drawing Submittals – None Required.
- B. Operation and Maintenance Manuals – None Required.
- C. Certificates and Guarantees – None Required.
- D. Spare Parts – None Required.

## 1.3 QUALITY ASSURANCE

- A. Comply with the following requirements:
  - 1. NFPA 70 National Electrical Code (NEC).
  - 2. Local codes and ordinances.
  - 3. Utility company providing electrical service.

## 1.4 DELIVERY, STORAGE, AND HANDLING

- A. Comply with pertinent provisions of Section 01 66 11.

## 1.5 SITE CONDITIONS – Reserved.

## 1.6 MAINTENANCE – Reserved.

## PART 2 - PRODUCTS

## 2.1 GENERAL

- A. Ground clamp fittings, connections, and joints:
  - 1. Provide interlocking listed clamp fabricated from high strength corrosion-resistant metal.

## GROUNDING AND BONDING OF ELECTRICAL SYSTEMS

26 05 26-1 (150826.40)

2. Use high strength silicon bronze U-bolt, nuts, and lock washers.
  3. Use high strength cast bronze ground rod clamp listed for direct burial for ground rod.
- B. Ground rods:
1. Provide copper or copper-clad steel core.
  2. Use 5/8-inch diameter minimum and 10-foot long.
- C. Ground wires:
1. Use copper wire only.
  2. Size as shown on the Drawings.

## PART 3 - EXECUTION

### 3.1 INSTALLATION

- A. Grounding electrode system:
1. Attach ground wire to a point ahead of water meter or service shut-off valve, when available.
  2. Attach ground wire to building steel where available.
- B. Main and supplemental grounding electrode conductors:
1. Install jumper or shunt around water meter and/or shut-off valve when applicable.
  2. Attach nonferrous metal tag at water pipe connection to warn against removal.
- C. Install properly terminated equipment grounding conductor in all flexible conduits.
- D. Drive ground rod to a depth that allows for physical protection and concealment below finished floor or grade. Leave approximately 4 inches of rod exposed for inspection prior to concealment.
- E. Make connections to ground rods with molded exothermic weld process, or a listed and approved ground rod clamp.

### 3.2 FIELD QUALITY CONTROL

- A. Perform and record resistance-to-earth measurements witnessed by Engineer with all grounding electrode conductors.
1. Isolate ground under test from other grounds.
  2. Measure in normally dry conditions not less than 48 hours after rainfall.
  3. Measure at each ground rod and other ground connections when applicable.
- B. Maximum D.C. resistance allowable is 5 ohms.
- C. Use the three-point method of measurement, unless specified otherwise.

END OF SECTION

SECTION 26 05 29

HANGERS AND SUPPORTS FOR ELECTRICAL SYSTEMS

PART 1 - GENERAL

1.1 SUMMARY

- A. Provide hangers and supports as shown on the Drawings, as specified herein, and as needed for a complete and proper installation.
- B. Related work:
  - 1. Documents affecting work under this Section include, but are not necessarily limited to, General Conditions, Supplementary Conditions, and Division 01 - General Requirements of these Specifications.
- C. References:
  - 1. Reserved.

1.2 SUBMITTALS

- A. Shop Drawing Submittals – None Required.
- B. Operation and Maintenance Manuals – None Required.
- C. Certificates and Guarantees – None Required.
- D. Spare Parts – None Required.

1.3 QUALITY ASSURANCE

- A. Comply with the following requirements:
  - 1. NFPA 70 National Electrical Code (NEC).
  - 2. Local codes and ordinances.

1.4 DELIVERY, STORAGE, AND HANDLING

- A. Comply with pertinent provisions of Section 01 66 11.

1.5 SITE CONDITIONS – Reserved.

1.6 MAINTENANCE – Reserved.

PART 2 - PRODUCTS

2.1 GENERAL

- A. Provide zinc galvanized, cadmium plated steel, or malleable iron supporting devices.

HANGERS AND SUPPORTS FOR ELECTRICAL SYSTEMS

26 05 29-1 (150826.40)

- B. Provide factory PVC-coated metal supports, clamps, and hardware when PVC-coated, galvanized rigid steel conduit is used.
  - 1. Comply with Section 26 05 33.
- C. Provide PVC supports, clamps and hardware for nonmetallic conduit system.
- D. Provide drilled expansion insert type sleeve anchors, lag shields, or plastic anchors suitable for load and application.

## 2.2 SUPPORTING STRUCTURES

- A. Provide rack supports of stainless steel channels with adequate feet for secure mounting.

## 2.3 MOUNTING PANELS

- A. Provide adequately braced and sized equipment mounting panels where required to mount equipment.
- B. Paint surfaces of panel to comply with Section 09 90 00.

## 2.4 CONDUIT SUPPORTS

- A. Provide continuous or T-slot concrete insert channel.
- B. Provide one-hole or two-hole conduit straps as required.

## PART 3 - EXECUTION

### 3.1 PREPARATION

- A. Determine if ceiling channel system is adequately supported to receive and support lighting fixtures.
  - 1. Where deemed inadequate, provide additional support to prevent ceiling from sagging.

### 3.2 INSTALLATION

- A. Install supporting devices in accordance with manufacturer's recommendations.
- B. Do not use perforated hanger iron.
- C. Pass conduit through pitch pocket at roof line when extending conduit through roof.

END OF SECTION

SECTION 26 05 33

RACEWAY AND BOXES FOR ELECTRICAL SYSTEMS

PART 1 - GENERAL

1.1 SUMMARY

- A. Provide raceway and boxes as shown on the Drawings, as specified herein, and as needed for a complete and proper installation.
- B. Related work:
  - 1. Documents affecting work under this Section include, but are not necessarily limited to, General Conditions, Supplementary Conditions, and Division 01 - General Requirements of these Specifications.
- C. References:
  - 1. Reserved.

1.2 SUBMITTALS

- A. Shop Drawing Submittals – None Required.
- B. Operation and Maintenance Manuals – None Required.
- C. Certificates and Guarantees – None Required.
- D. Spare Parts – None Required.

1.3 QUALITY ASSURANCE

- A. Comply with the following requirements:
  - 1. NFPA 70 National Electrical Code (NEC).
  - 2. Local codes and ordinances.

1.4 DELIVERY, STORAGE, AND HANDLING

- A. Comply with pertinent provisions of Section 01 66 11.

1.5 SITE CONDITIONS – Reserved.

1.6 MAINTENANCE – Reserved.

PART 2 - PRODUCTS

2.1 GENERAL

- A. Provide conduit system of the types of conduit as indicated in the Conduit Usage Schedule in Part 3 of this Section.

RACEWAY AND BOXES FOR ELECTRICAL SYSTEMS

26 05 33-1 (150826.40)



- B. Provide junction boxes as necessary to facilitate pulling and/or splicing of wires.
- C. Provide factory PVC-coated boxes of same coating thickness as conduit system where PVC-coated conduit is used (except hazardous classified areas).
- D. Provide PVC boxes where non-metallic conduit system is used.

## 2.2 METAL RACEWAY AND FITTINGS

- A. Galvanized rigid steel conduit (GRC) and fittings:
  - 1. Conduit: Comply with ANSI C80.1 and UL 6 standards.
  - 2. Fittings: Comply with UL 514B and NEMA FB1 & FB2.10 standards.
- B. Intermediate metal conduit (IMC) and fittings:
  - 1. Conduit: Comply with ANSI C80.6 and UL 1242 standards.
  - 2. Fittings: Comply with UL 514B and NEMA FB1 & FB2.10 standards.
- C. Electrical metallic tubing (EMT) and fittings:
  - 1. Conduit: Comply with ANSI C80.3 and UL 797 standards.
  - 2. Fittings: Comply with UL 514B and NEMA FB1 & FB2.10 standards.
- D. Polyvinyl-chloride (PVC) coated galvanized rigid steel conduit and fittings.
  - 1. Conduit: Comply with ANSI C80.1, UL 6, and NEMA RN1 standards.
    - a. Galvanized rigid steel conduit with full weight 40 mil thick PVC exterior coating.
    - b. PVC bonding to galvanized metal shall be stronger than plastic tensile strength.
    - c. Provide nominal 2 mil thick urethane, or equal, coating to inside of conduit.
  - 2. Fittings:
    - a. Comply with UL 514B and NEMA RM1 standards.
    - b. Threaded with full weight 40 mil thick PVC exterior coating.
    - c. Inside coating: Nominal 2 mil thick urethane, or equal.
    - d. Provide pressure sealing sleeves on all conduit openings.
  - 3. Accessories: Provide straps, clamps, and screws with full weight 40 mil thick PVC exterior coating.
  - 4. Provide factory-installed PVC coating on all components of PVC coated conduit system.
    - a. Use coating in field only for touch-up of components.
- E. Rigid aluminum conduit and fittings:
  - 1. Conduit: Comply with ANSI C80.5 and UL 6 standards.
  - 2. Fittings: Threaded, and in compliance with Comply with UL 514B and NEMA FB1 standards.

## 2.3 FLEXIBLE METAL RACEWAY AND FITTINGS

- A. Liquidtight, flexible metal conduit and fittings:
  - 1. Conduit: Comply with UL 360 standards.
    - a. Galvanized flexible steel core.

- b. Provide outer liquidtight, PVC sunlight resistant jacket.
2. Fittings: Comply with UL 514B and NEMA FB1 standards.

B. Flexible metal conduit and fittings:

1. Conduit: Comply with UL 1 standards.
2. Fittings: Comply with UL 514B and NEMA FB1 standards.

## 2.4 NON-METALLIC RACEWAY AND FITTINGS

A. Rigid conduit: Comply with ANSI C80.3, ASTM F512, NEMA TC-2 and UL 651 standards.

1. Use heavy wall, sunlight resistant, PVC Schedule 40 or 80 as shown on the Drawings.
2. Rated for use with 90 degree C. conductors.

B. Liquid tight, flexible conduit: Comply with ANSI-79 and UL 1660 standards.

1. Fittings: Liquid-tight.

C. Fittings:

1. Comply with UL 514C and NEMA TC3 standards.
2. Schedule 40 or 80 to match conduit.

## 2.5 CONDUIT BODIES

A. Metallic conduit bodies:

1. Comply with ANSI C80.4 and C33.84, and UL 514 standards.
  - a. Use galvanized or cadmium plated malleable iron, or copper-free aluminum material.
  - b. Provide factory PVC-coated conduit bodies of same coating thickness as conduit where PVC-coated conduit is used.

B. Non-metallic conduit bodies:

1. Comply with ASTM F512 and UL 514 and 651 standards.
  - a. Compatible with Schedule 40 or 80 conduit.
  - b. UL listed for use.

C. Provide removable cover with gasket and corrosion-resistant screws.

## 2.6 WALL AND FLOOR SLEEVES

- A. Comply with requirements of Section 22 19 13.

## 2.7 FLEXIBLE SEALING COMPOUND

- A. Use Panduit DS-5 duct sealing compound, or equal, where air and vaportight conduit sealing is required.

## 2.8 OUTLET BOXES AND JUNCTION BOXES

- A. Surface mounted: Provide corrosion-resistant single or multiple gang malleable iron or aluminum Type FS or FD cast boxes with threaded hubs, or pressed steel boxes as permitted under Part 3 of this Section.
- B. Weatherproof boxes: Provide gasketed covers and corrosion-proof fasteners.

## 2.9 PULL BOXES AND SPECIAL PURPOSE OUTLET BOXES

- A. Provide pull boxes with covers held in place by corrosion-resistant machine screws, and of type or NEMA rating as shown on the Drawings.
- B. Provide special purpose outlet boxes furnished with fixtures and devices where standard outlets are not applicable.

## PART 3 - EXECUTION

### 3.1 INSTALLATION - RACEWAY

- A. Install conduit and fittings in accordance with manufacturer's recommendations.
- B. Run exposed conduits parallel to or at right angles with lines of building or structure.
- C. Route conduit runs above suspended panel ceilings so as not to interfere with panel removals.
- D. Keep conduit plugged, clean and dry during construction.
- E. Install wall sleeves as shown on the Drawings where conduits pass through foundation walls below grade.
- F. Conduit runs extending through areas of different temperature or atmospheric conditions, or partly indoors and partly outdoors must be sealed, drained, and installed in a manner preventing drainage of condensed or entrapped moisture into cabinets, boxes, fixtures, motors, or equipment enclosures.
- G. Conduits run in concrete structures:
  - 1. Comply with applicable provisions of ACI 318 for conduits embedded in structural frame slab.
  - 2. Install conduits parallel to each other spaced on center of at least three times conduit trade diameter with minimum 2-inch concrete covering.
  - 3. Conduits over 1-1/2 inches may not be installed in slab without approval of Engineer.
- H. Install bushings with ground lugs and integral plastic linings at equipment with open-bottom conduit entrances.

- I. In precast areas, run conduits in roof insulation space. Use 3/4-inch maximum conduit size.
- J. Exterior underground conduit:
  - 1. Comply with pertinent provisions of Section 31 23 79.
  - 2. Provide conduits or ducts terminating below grade with means to prevent entry of dirt or moisture.

### 3.2 INSTALLATION – BOXES

- A. Install boxes in accordance with manufacturer's recommendations.
- B. Use weatherproof boxes for interior and exterior locations exposed to weather or moisture.
- C. Do not install boxes back to back or through wall. Off set outlet boxes on opposite sides of wall minimum 12 inches.
- D. Set outlet boxes parallel to construction.
- E. Thoroughly clean boxes prior to installing wiring devices.

### 3.3 CUTTING AND PATCHING

- A. Make provisions for openings, holes, and clearances through walls, floors, ceilings, and partitions in advance of construction.
- B. Cut and patch in accordance with Section 01 73 29.
- C. Core drill through reinforced concrete with approval of Engineer.

### 3.4 RESTRICTIONS

- A. Cross high temperature piping or ducts with 12-inch clearance.
- B. Do not route conduit over boiler, incinerator, or other high temperature equipment, piping, or ducts.
- C. Do not route exposed conduit below and parallel to, or adjacent to water piping.
- D. Do not use EMT indenter-type fittings on EMT conduit.

### 3.5 CONDUIT USAGE SCHEDULE

- A. Install GRC when in contact with earth or fill unless otherwise shown on the Drawings.
- B. Install GRC or IMC in the following locations unless otherwise shown on the Drawings:
  - 1. Concealed in poured concrete walls and floor or roof slabs.

2. Concealed in insulation above poured or precast concrete roof slabs.
  3. Exposed.
- C. EMT conduit may be installed in the following locations unless otherwise shown on the Drawings:
1. Above suspended ceilings.
  2. In attic spaces.
  3. Concealed in walls, hollow metal or wood framed floors, ceilings, soffits, and overhangs.
  4. Concealed by counter base cabinets.
  5. Inside exterior electrical enclosures.
- D. Install liquidtight flexible metal conduit and fittings for connections to motors, instrumentation, transformers (primary and secondary connections), and equipment subject to vibration and at locations shown on the Drawings.
- E. Install PVC coated galvanized rigid steel conduit, rigid aluminum conduit, and rigid non-metallic conduit only when shown on the Drawings.

### 3.6 EXPOSED OUTLET AND JUNCTION BOXES

- A. Use cast boxes up to 45 inches above floor.
- B. Pressed steel boxes acceptable over 45 inches above floor in dry, indoor locations.
- C. Install weatherproof outlet, switch, and junction boxes outdoors and in any area where Drawings show weatherproof (WP) wiring devices.

### 3.7 OUTLET BOX ACCESSORIES

- A. Provide outlet box accessories and mounting devices as required for each installation.

### 3.8 OUTLET BOX LOCATIONS

- A. Location of outlets and equipment is approximate. Exact location to be verified and determined by:
  1. Conflict with equipment of other trades.
  2. Equipment manufacturer's drawings.
  3. Engineer in field.
- B. Minor modification in location of outlets and equipment is considered incidental up to distance of 10 feet with no additional compensation, providing necessary instructions are given prior to roughing-in of outlet boxes and equipment.
- C. Nominal mounting heights for devices and equipment to be measured from either above finished floor (AFF) or above finished grade (AFG) to center line of device and, unless otherwise shown on the Drawings, are as follows:
  1. Switches: 48 inches AFF OR AFG.

2. AC receptacles and telephone outlets: 48 inches AFF or AFG.
3. Thermostats: 60 inches above floor.

END OF SECTION

SECTION 26 05 53

IDENTIFICATION FOR ELECTRICAL SYSTEMS

PART 1 - GENERAL

1.1 SUMMARY

- A. Provide identification for electrical systems as shown on the Drawings, as specified herein, and as needed for a complete and proper installation.
- B. Related work:
  - 1. Documents affecting work under this Section include, but are not necessarily limited to, General Conditions, Supplementary Conditions, and Division 01 - General Requirements of these Specifications.
- C. References:
  - 1. Reserved.

1.2 SUBMITTALS

- A. Shop Drawing Submittals – None Required.
- B. Operation and Maintenance Manuals – None Required.
- C. Certificates and Guarantees – None Required.
- D. Spare Parts – None Required.

1.3 QUALITY ASSURANCE – Reserved.

1.4 DELIVERY, STORAGE, AND HANDLING

- A. Comply with pertinent provisions of Section 01 66 11.

1.5 SITE CONDITIONS – Reserved.

1.6 MAINTENANCE – Reserved.

PART 2 - PRODUCTS

2.1 NAMEPLATES AND TAGS

- A. Provide nameplates or tags for identification of panels, panel components, and field mounted devices with the following requirements.
  - 1. Engraved laminated plastic.

IDENTIFICATION FOR ELECTRICAL SYSTEMS

26 05 53-1 (150826.40)

2. White or black letters on background of opposite color. Match and coordinate color of nameplate or tag background with other panels.
- B. Panel nameplates to have 1/2-inch high letter engraving.
  - C. Device and component nameplates or tags to have 3/16-inch high letter engraving.
  - D. Engravings include the following:
    1. Alpha-numeric number.
    2. Descriptive title.
    3. Range, where applicable.
    4. Engineering units, where applicable.

### PART 3 - EXECUTION

#### 3.1 INSTALLATION

- A. Install nameplates and tags on enclosures, panel mounted components, and field mounted devices.

END OF SECTION



SECTION 26 09 95

PUSHBUTTONS, SELECTOR SWITCHES, AND PILOT LIGHTS

PART 1 - GENERAL

1.1 SUMMARY

- A. Provide pushbuttons, selector switches, and pilot lights as shown on the Drawings, as specified herein, and as needed for a complete and proper installation.
- B. Related work:
  - 1. Documents affecting work under this Section include, but are not necessarily limited to, General Conditions, Supplementary Conditions, and Division 01 - General Requirements of these Specifications.
- C. References:
  - 1. Reserved.

1.2 SUBMITTALS

- A. Shop Drawing Submittals:
  - 1. Manufacturer's detailed specifications.
- B. Operation and Maintenance Manuals – None Required.
- C. Certificates and Guarantees – None Required.
- D. Spare Parts:
  - 1. Two (2) pilot light lamps of each type.

1.3 QUALITY ASSURANCE

- A. Comply with the following requirements:
  - 1. NFPA 70, National Electrical Code (NEC).
  - 2. Local codes and ordinances.

1.4 DELIVERY, STORAGE, AND HANDLING

- A. Comply with pertinent provisions of Section 01 66 11.

1.5 SITE CONDITIONS – Reserved.

1.6 MAINTENANCE – Reserved.

## PART 2 - PRODUCTS

### 2.1 GENERAL

- A. Provide oil-tight, heavy duty NEMA 4 rated pushbutton switches, selector switches, and pilot lights.
- B. Provide all devices with legend plates.
  - 1. Material: Non-tarnish metal or laminated plastic.
  - 2. Use white or black letters on background of opposite color for laminated plastic.
- C. Use two-circuit contact blocks (one N.O. and one N.C. contact set) for pushbutton switches and selector switches.

### 2.2 PUSHBUTTON SWITCHES

- A. Stop pushbuttons:
  - 1. Provide non-illuminated momentary operation type operators.
  - 2. Use red color button.
- B. Start pushbuttons:
  - 1. Provide non-illuminated momentary operation type operators.
  - 2. Use black color button.
- C. Stop-hold switches:
  - 1. Use stop pushbutton as specified above.
  - 2. Include sliding latch with padlock provision to engage stop button in the OFF position.
- D. Provide pushbuttons for other functions as shown on the Drawings.

### 2.3 SELECTOR SWITCHES

- A. Provide selector switches including the operating knob, operating cam and contact block(s).
- B. Use black color operating knob.
- C. Select operating cam and contact block combination to provide operating sequence as required.

### 2.4 PILOT LIGHTS

- A. Provide pilot lights with colored plastic lens as shown on the Drawings.
- B. Provide 120 volt or 24 Vdc, push-to-test type with LED lamp.

## 2.5 ENCLOSURES

- A. Provide for individual remote control or monitor stations the following type enclosure:
  - 1. Indoor locations: NEMA 1.
  - 2. Outdoor or wet locations: NEMA 3R or NEMA 4 steel construction.
  - 3. Corrosive locations: NEMA 4X stainless steel construction.
  
- B. Provide nameplate on enclosure for device being controlled.
  - 1. Provide engraved laminated plastic type.
  - 2. Use 3/16-inch high white or black letters on background of opposite color.

## PART 3 - EXECUTION

### 3.1 INSTALLATION

- A. Install pushbutton switches, selector switches, and pilot lights in accordance with manufacturer's recommendations.

END OF SECTION

## SECTION 26 24 16

## PANELBOARDS

## PART 1 - GENERAL

## 1.1 SUMMARY

- A. Provide panelboards as shown on the Drawings, as specified herein, and as needed for a complete and proper installation.
- B. Related work:
  - 1. Documents affecting work under this Section include, but are not necessarily limited to, General Conditions, Supplementary Conditions, and Division 01 - General Requirements of these Specifications.
- C. References:
  - 1. Reserved.

## 1.2 SUBMITTALS

- A. Shop Drawing Submittals:
  - 1. Cabinet dimensions.
  - 2. Nameplate nomenclature.
  - 3. Electrical ratings and characteristics.
  - 4. Type, amperage rating, listing, and position of circuit breakers in panelboard.
  - 5. Manufacturer's detailed specifications.
- B. Operation and Maintenance Manuals – None Required.
- C. Certificates and Guarantees – None Required.
- D. Spare Parts – None Required.

## 1.3 QUALITY ASSURANCE

- A. Comply with the following requirements:
  - 1. NFPA 70 National Electrical Code (NEC).
  - 2. Local codes and ordinances.
  - 3. Provide all panelboards of one manufacturer.

## 1.4 DELIVERY, STORAGE, AND HANDLING

- A. Comply with pertinent provisions of Section 01 66 11.

## 1.5 SITE CONDITIONS – Reserved.

## 1.6 MAINTENANCE – Reserved.

## PART 2 - PRODUCTS

### 2.1 GENERAL

- A. Comply with the following standards:
  - 1. NEMA AB 1 - Molded Case Circuit Breakers and Molded Case Switches.
  - 2. NEMA FU 1 - Low Voltage Cartridge Fuses.
  - 3. NEMA ICS 2 - Industrial Control and Systems: Controllers, Contactors, and Overload Relays, Rated Not More Than 2000 Volts AC or 750 Volts DC.
  - 4. NEMA ICS 5 - Industrial Control and Systems: Control Circuit and Pilot Devices.
  - 5. NEMA KS 1 - Enclosed and Miscellaneous Distribution Equipment Switches (600 Volts Maximum).
  - 6. NEMA PB 1 - Panelboards.
  - 7. NEMA PB 1.1 - General Instructions for Proper Installation, Operation, and Maintenance of Panelboards Rated 600 Volts or less.
- B. Comply with the requirements of UL 50, 67, and NEMA PB1 standards.
- C. Provide short circuit rating (integral equipment rating) for available fault current.
- D. Provide panelboard construction with the following:
  - 1. Neutral bus with terminals.
  - 2. Plated or tinned copper bussing:
    - a. Distributed phase sequence type.
    - b. Ratings as shown on the Drawings, 100 ampere minimum.
  - 3. Branch circuit breakers:
    - a. Comply with Section 26 28 00.
    - b. Ratings as shown on the Drawings.
    - c. UL Class A ground fault circuit protection (GFP) as required.
  - 4. Circuit directory:
    - a. Directory card suitable for complete descriptions.
    - b. Clear plastic cover.
    - c. Card holder attached to inside of panel door.
- E. Provide main lugs or main circuit breaker rated as shown on the Drawings.
  - 1. Main circuit breaker: Comply with Section 26 28 00.
- F. Listed for non-linear loads.

## PART 3 - EXECUTION

### 3.1 INSTALLATION

- A. Install panelboards in accordance with manufacturer's recommendations.

### 3.2 RESTRICTIONS

- A. Separation of hot wires and respective neutral wires where they enter a panelboard is not permitted.
  - 1. All ungrounded and grounded (hot and neutral) conductors of each feeder circuit and each branch circuit must be grouped together where they enter through knock-outs or slots into a panelboard gutter area.
  - 2. Comply with N.E.C. Section 300.20.

### 3.3 FIELD QUALITY CONTROL

- A. Energize each circuit and check for complete and correct function.

END OF SECTION

SECTION 26 27 26

WIRING DEVICES

PART 1 - GENERAL

1.1 SUMMARY

- A. Provide wiring devices as shown on the Drawings, as specified herein, and as needed for a complete and proper installation.
- B. Related work:
  - 1. Documents affecting work under this Section include, but are not necessarily limited to, General Conditions, Supplementary Conditions, and Division 01 - General Requirements of these Specifications.
- C. References:
  - 1. Reserved.

1.2 SUBMITTALS

- A. Shop Drawing Submittals – None Required.
- B. Operation and Maintenance Manuals – None Required.
- C. Certificates and Guarantees – None Required.
- D. Spare Parts – None Required.

1.3 QUALITY ASSURANCE

- A. Comply with the following requirements:
  - 1. NFPA 70 National Electrical Code (NEC).
  - 2. Local codes and ordinances.

1.4 DELIVERY, STORAGE, AND HANDLING

- A. Comply with pertinent provisions of Section 01 66 11.

1.5 SITE CONDITIONS – Reserved.

1.6 MAINTENANCE – Reserved.

PART 2 - PRODUCTS

2.1 GENERAL

- A. Provide wiring devices in type and electrical rating for service indicated.

- B. See symbol schedule on Drawings for identification of device type.
- C. Acceptable manufacturers:
  - 1. Hubbell.
  - 2. Leviton.
  - 3. Or equal.

## 2.2 SWITCHES

- A. General use lighting switches:
  - 1. Comply with UL 20, NEMA WD-1, and Federal Specification W-S-896 standards.
  - 2. Provide industrial grade, 20 ampere, toggle type switches.

## 2.3 RECEPTACLES

- A. Comply with UL 498, NEMA WD-1 & WD-6, and Federal Specification W-C-596 standards.
- B. General use single and duplex, 125 volt receptacles:
  - 1. Provide industrial grade, NEMA 5-20R grounding type receptacles rated at 20 amperes.
- C. Ground fault circuit interrupter receptacles:
  - 1. Comply with UL 943 Class A standard.
  - 2. Provide industrial grade, GFCI duplex receptacles rated at 20 amperes, 120 volts.
  - 3. Provide construction as follows:
    - a. Shallow depth and NEMA 5-20R configuration.
    - b. Feed-through feature.

## 2.4 WIRING DEVICE PLATES AND COVER

- A. Comply with UL 514D.
- B. Plates of interior flush mounted devices: Provide high impact thermoplastic polycarbonate, nylon or stainless steel.
- C. Device plates for surface mounted Type FS or FD boxes: Provide type FSK galvanized steel covers.
- D. Device plates for surface mounted, 4-inch square boxes: Provide 1/2-inch raised galvanized steel covers.
- E. Weatherproof (WP) plates and covers: Provide with gasketed, lift cover.
  - 1. Provide lift cover designed to be fully closed when plug for dedicated equipment is inserted in receptacle.



## PART 3 - EXECUTION

### 3.1 INSTALLATION

- A. Install wiring devices in accordance with manufacturer's recommendations.
- B. Install gasket plates for devices or system components having light emitting features, such as switch with pilot light.
- C. Install devices at height as specified in Section 26 05 33 or as shown on the Drawings.
- D. Do not use combination type switch/switch or switch/receptacle devices.
  - 1. Provide separate box gang for each switch and receptacle.
- E. Thoroughly clean box interiors from construction dust, debris, etc. prior to installing wiring devices.

### 3.2 FIELD QUALITY CONTROL

- A. Provide operational testing for devices.
- B. Test receptacles for correct polarity, proper ground connection, and wiring faults.

END OF SECTION

## SECTION 26 28 00

## LOW-VOLTAGE CIRCUIT PROTECTIVE DEVICES

## PART 1 - GENERAL

## 1.1 SUMMARY

- A. Provide overcurrent protective devices as shown on the Drawings, as specified herein, and as needed for a complete and proper installation.
- B. Related work:
  - 1. Documents affecting work under this Section include, but are not necessarily limited to, General Conditions, Supplementary Conditions, and Division 01 - General Requirements of these Specifications.
- C. References:
  - 1. Reserved.

## 1.2 SUBMITTALS

- A. Shop Drawing Submittals:
  - 1. Electrical ratings, physical size, interrupt ratings, trip curves, I<sup>2</sup>t curves, and manufacturer's detailed specifications.
- B. Operation and Maintenance Manuals – None Required.
- C. Certificates and Guarantees – None Required.
- D. Lubricants – None Required.
- E. Spare Parts – Provide the following spare parts to the Owner that match items specified:
  - 1. In three phase circuits: Three (3) fuses of each type and rating.
  - 2. In single phase circuits: Two (2) fuses of each type and rating.

## 1.3 QUALITY ASSURANCE

- A. Comply with the following requirements:
  - 1. NFPA 70 National Electrical Code (NEC).
  - 2. Local codes and ordinances.
  - 3. Provide overcurrent protective devices by same manufacturer for each type of device.

## 1.4 DELIVERY, STORAGE, AND HANDLING

- A. Comply with pertinent provisions of Section 01 66 11.

## LOW-VOLTAGE CIRCUIT PROTECTIVE DEVICES

26 28 00-1 (150826.40)

1.5 SITE CONDITIONS – Reserved.

1.6 MAINTENANCE – Reserved.

## PART 2 - PRODUCTS

### 2.1 FUSES

- A. General purpose fuses for protection of motor control circuits, lighting ballasts, control transformers, and street lighting fixtures:
  - 1. Use UL Class CC, fast acting, single element fuses.
  - 2. Rated for 0-30 amperes.
  - 3. Provide 200,000 ampere interrupting capacity.
  - 4. Use Bussman Limitron KTK-R, or equal: 600 volt rating.

### 2.2 MOLDED CASE CIRCUIT BREAKERS

- A. General:
  - 1. Comply with UL 489 requirements.
  - 2. Provide thermal and magnetic protection.
- B. Provide permanent trip lighting panel circuit breakers as follows:
  - 1. UL listed SWD (switching duty) on 120 volt circuits where switched circuits are indicated.
  - 2. Short circuit rating (integrated equipment rating):
    - a. Up to 240 volt: 10,000 RMS symmetrical amps minimum.
    - b. Up to 480 volt: 14,000 RMS symmetrical amps minimum.
- C. Provide permanent trip power panel circuit breakers as follows:
  - 1. Single magnetic trip adjustment.
  - 2. Bolt-on type.
  - 3. Short circuit rating (integrated equipment rating):
    - a. Main: 42,000 RMS symmetrical amps minimum.
    - b. Branch: 14,000 RMS symmetrical amps minimum.

## PART 3 - EXECUTION

### 3.1 INSTALLATION

- A. Install overcurrent protective devices in accordance with manufacturer's recommendations.

### 3.2 ADJUSTMENT

- A. Set and record adjustable settings on circuit breakers to provide selective coordination and proper operation.

END OF SECTION

SECTION 26 28 16

ENCLOSED SWITCHES AND CIRCUIT BREAKERS

PART 1 - GENERAL

1.1 SUMMARY

- A. Provide enclosed switches and circuit breakers as shown on the Drawings, as specified herein, and as needed for a complete and proper installation.
- B. Related work:
  - 1. Documents affecting work under this Section include, but are not necessarily limited to, General Conditions, Supplementary Conditions, and Division 01 - General Requirements of these Specifications.
- C. References:
  - 1. Reserved.

1.2 SUBMITTALS

- A. Shop Drawing Submittals:
  - 1. Electrical ratings, physical dimensions, NEMA rating, and manufacturer's detailed specifications.
- B. Operation and Maintenance Manuals – None Required.
- C. Certificates and Guarantees – None Required.
- D. Spare Parts – None Required.

1.3 QUALITY ASSURANCE

- A. Comply with the following requirements:
  - 1. NFPA 70 National Electrical Code (NEC).
  - 2. Local codes and ordinances.

1.4 DELIVERY, STORAGE, AND HANDLING

- A. Comply with pertinent provisions of Section 01 66 11.

1.5 SITE CONDITIONS – Reserved.

1.6 MAINTENANCE – Reserved.

## PART 2 - PRODUCTS

### 2.1 GENERAL

- A. Provide disconnect with the following ratings:
  - 1. 240 volt or 600 volt AC as required by circuit voltage.
  - 2. Ampere value as shown on Drawings.
  - 3. UL listed short circuit rating of 200,000 RMS amps with Class R fuses where a fused disconnect is indicated.
    - a. Comply with Section 26 28 00.

### 2.2 SAFETY SWITCH

- A. Provide NEMA heavy-duty, quick-make and quick-break type:
  - 1. Cover interlock mechanism with handle attached to box.
    - a. Handle position indication of ON in up position and OFF in down position.
  - 2. Padlock provision in the ON and OFF positions.
  - 3. Provisions for insulated or bonded neutral.
  - 4. Provision for control circuit interlock.

### 2.3 ENCLOSURES

- A. Indoor: Provide NEMA 3R steel construction.
- B. Outdoor area: Provide NEMA 3R or NEMA 4 steel construction.

### 2.4 NAMEPLATES

- A. Provide engraved laminated plastic type.
- B. Use 3/16-inch high white or black letters on background of opposite color.
- C. Identify disconnect means as follows:
  - 1. Disconnect: For purpose of switch or equipment controlled.

## PART 3 - EXECUTION

### 3.1 INSTALLATION

- A. Install motor and circuit disconnects in accordance with manufacturer's recommendations.

END OF SECTION

SECTION 26 60 20  
ELECTRICAL SERVICE

PART 1 - GENERAL

1.1 SUMMARY

- A. Provide electrical service as shown on the Drawings, as specified herein, and as needed for a complete and proper installation.
- B. References:
  - 1. Reserved.

1.2 SUBMITTALS

- A. Shop Drawing Submittals – None Required.
- B. Operation and Maintenance Manuals – None Required.
- C. Certificates and Guarantees – None Required.
- D. Spare Parts – None Required.

1.3 QUALITY ASSURANCE

- A. Comply with the following requirements:
  - 1. NFPA 70 National Electrical Code (NEC).
  - 2. Local codes and ordinances.
  - 3. Utility Company providing service.

1.4 DELIVERY, STORAGE, AND HANDLING

- A. Comply with pertinent provisions of Section 01 66 11.

1.5 SITE CONDITIONS – Reserved.

1.6 MAINTENANCE – Reserved.

PART 2 - PRODUCTS

2.1 ELECTRIC POWER SERVICE

- A. Electrical service for the site: Underground 480Y/277 volt, 3 phase, 4 wire, provided by Alliant Energy (Utility Company) along with a pad mounted transformer to provide service to the elevated tank.

## PART 3 - EXECUTION

### 3.1 PREPARATION

- A. Coordinate electrical service to site with Utility Company and Owner/Engineer.

### 3.2 INSTALLATION

- A. The Utility Company will provide the following:
  - 1. Underground service from Old Sauk to the utility transformer located just east of the elevated tank.
  - 2. Utility Meter.
- B. Contractor to provide the following and all other related electrical work and miscellaneous materials for a complete installation:
  - 1. Concrete transformer pad meeting Alliant Energy requirements and details.
  - 2. Conduits and wiring from transformer to metering equipment located on exterior of the tank pedestal walls. Provide ESE E116 approved Pedestal.
  - 3. Tank wall penetrations, conduit and wiring to 200 amp lighting panel as shown on the Drawings along with grounding.

### 3.3 OWNER RESPONSIBILITY

- A. Owner will pay directly to Utility Company all Utility installation and/or excess facilities charges, if any, and monthly service charges.

END OF SECTION

SECTION 28 31 00  
FIRE DETECTION AND ALARM

PART 1 - GENERAL

1.1 SUMMARY

- A. Provide fire detection and alarm as shown on the Drawings, as specified herein, and as needed for a complete and proper installation.
- B. Related work:
  - 1. Documents affecting work under this Section include, but are not necessarily limited to, General Conditions, Supplementary Conditions, and Division 01 - General Requirements of these Specifications.
- C. Comply with the requirements and codes of the local fire department having jurisdiction.
- D. References:
  - 1. Reserved.

1.2 SUBMITTALS

- A. Shop Drawing Submittals:
  - 1. The smoke detection equipment, including dimension drawings, electrical wiring diagrams, and manufacturer's detailed specifications.
- B. Operation and Maintenance Manuals – Submit operation and maintenance manuals for the smoke detector in compliance with pertinent provisions of Section 01 78 26.
- C. Certificates and Guarantees – None Required.
- D. Spare Parts – None Required.

1.3 QUALITY ASSURANCE – Reserved.

1.4 DELIVERY, STORAGE, AND HANDLING – Reserved.

1.5 SITE CONDITIONS – Reserved.

1.6 MAINTENANCE – Reserved.

PART 2 - PRODUCTS

2.1 SMOKE DETECTORS

- A. Provide photoelectric smoke detectors where indicated on the Drawings as follows:
  - 1. Includes red LED indicator that:
    - a. Flashes once every 15 seconds to indicate unit is powered.



- b. Emits a steady light when smoke is sensed.
- c. Automatically resets when smoke condition is cleared.
- 2. Includes one form A SPST and one form C DPDT dry contact sets rated 1 amp at 30 volts DC and 120 volts AC resistive that:
  - a. Reverse state when smoke is sensed.
  - b. Automatically return to quiescent state when smoke condition is cleared.
- 3. Emits an intermittent horn sound when smoke is sensed.
  - a. Automatically silences when smoke condition is cleared.
- 4. Includes test pushbutton on front cover.
- 5. Includes provision for tandem alarm activation of other detectors wired to same circuit.
- 6. Detection chamber includes pulsing LED light source and smoke sensing photodiode:
  - a. LED pulse rate is  $\pm$  once every 4 seconds.
  - b. Alarm is sounded when detector verifies presence of smoke through 2 successive pulses of LED.
- 7. Operates on 120 volts, 60 Hertz AC.

### PART 3 - EXECUTION

#### 3.1 INSPECTION

- A. Examine areas and condition under which alarm system is to be installed and notify Engineer, in writing, of conditions detrimental to proper and timely completion of work.
- B. Do not proceed with work until unsatisfactory conditions have been corrected.

#### 3.2 INSTALLATION

- A. Install smoke detectors and interconnect alarm signals to remote alarm bell and horns, and to telemetry/SCADA panel.

#### 3.3 START-UP AND TESTING

- A. Comply with the requirements of Section 01 61 01 for start-up, testing, and calibration of all instruments, devices, and complete system.
- B. Start-up and testing to be the responsibility of the system supplier.

END OF SECTION

SECTION 31 16 00  
SITE PREPARATION

PART 1 - GENERAL

1.1 SUMMARY

- A. This Section describes clearing and grubbing the site as shown on the Drawings and specified in this Section.
- B. Related work:
  - 1. Documents affecting work of this Section include, but are not necessarily limited to, General Conditions, Supplementary Conditions, and Division 01 – General Requirements of these Specifications.

1.2 QUALITY ASSURANCE

- A. Use adequate numbers of skilled workmen who are thoroughly trained and experienced in the necessary crafts and who are completely familiar with the specified requirements and the methods needed for proper performance of the work of this Section.

1.3 DELIVERY, STORAGE, AND HANDLING

- A. Comply with pertinent provisions of Section 01 66 11.

PART 2 - PRODUCTS

2.1 MATERIALS

- A. Provide materials, not specifically described but required for proper completion of the work of this Section, as selected by the Contractor subject to the approval of the Engineer.

PART 3 - EXECUTION

3.1 SURFACE CONDITIONS

- A. Examine the areas and conditions under which work of this Section will be performed. Correct conditions detrimental to timely and proper completion of the Work. Do not proceed until unsatisfactory conditions are corrected.

3.2 PROTECTION

- A. Obtain approval to remove brush and trees from fence-line along Old Sauk road prior to any removal on site.

- B. Protect existing utilities indicated or made known.
- C. Protect trees and shrubs, where indicated to remain, by plank wrappers securely wired in place or by providing a fence around the tree or shrub of sufficient distance away and of sufficient height so trees and shrubs will not be damaged in any way as part of this Work.
  - 1. Do not permit any equipment to operate within 5 feet of any trees or shrubs that are to remain or in a manner as to harm overhanging branches.
- D. Protection of persons and property:
  - 1. Barricade open depressions and holes occurring as part of this Work, and post warning lights on property adjacent to or with public access.
  - 2. Operate warning lights during hours from dusk to dawn each day and as otherwise required.
  - 3. Protect structures, utilities, sidewalks, pavements, and other facilities from damage caused by settlement, lateral movement, undermining, washout, and other hazards created by operations under this Section.
- E. Use means necessary to prevent dust becoming a nuisance to the public, to neighbors, and to other work being performed on or near the site.
- F. Maintain access to the site at all times.

### 3.3 CLEARING

- A. Tree removal:
  - 1. Cut off trees and stumps at the existing ground level. Remove stumps and roots as needed.
  - 2. Remove trees and stumps within 6 feet of the proposed structures and underground piping to a depth of not less than 12 inches below the base elevation of proposed structures or underground piping.

### 3.4 CONSERVATION OF TOPSOIL

- A. After the area has been cleared of vegetation, strip the existing topsoil in construction and construction laydown areas, without contamination with subsoils.
- B. Stockpile topsoil in an area clear of new construction.
- C. Maintain the stockpile in a manner which will not obstruct the natural flow of drainage.
  - 1. Maintain stockpile free from debris and trash.
  - 2. Keep the topsoil damp to prevent dust and drying out.
  - 3. Provide silt fences around perimeters of all stockpiles.
  - 4. Provide temporary seeding of stockpiles.
  - 5. Comply with erosion and sediment control requirements of these specifications and all permitting agencies.

### 3.5 DISPOSAL

- A. General:
  - 1. Remove and dispose of all debris from clearing and demolition work.
  - 2. Dispose away from the site in a legal manner.
  - 3. Do not store or accumulate debris at the job site.
- B. Do not burn debris at the site.
- C. Do not conduct any generation, transportation, or recycling of construction or demolition debris, clean or general or uncontaminated soil generated during construction, remodeling, repair, and demolition of utilities, structures, and roads that is not commingled with any waste, without the maintenance of documentation identifying the hauler, generator, place of origin of the debris or soil, the weight or volume of the debris or soil, and the location, owner, and operator of the facility where the debris or soil was transferred, disposed, recycled or treated. Maintain documentation for three years.

### 3.6 UTILITIES

- A. Coordinate with utility companies and agencies as required.
- B. Where utility cutting, capping, or plugging is required, pay Utility Company to do the work or perform such work in accordance with requirements of the utility company or governmental agency having jurisdiction.

END OF SECTION

## SECTION 31 22 22

## EARTHWORK FOR ROADS, DRIVEWAYS, AND WALKS

## PART 1 - GENERAL

## 1.1 SUMMARY

- A. This Section describes earthwork, including clearing, tree removal, hedge removal, excavation, embankment, compaction, and subgrade preparation for constructing roads, driveways, and sidewalks as shown on the Drawings, as specified herein, and as needed for a complete installation.
- B. Construct the work of this section in accordance with the WDOT "Standard Specifications" except as herein modified.
- C. Related works:
  - 1. Documents affecting work of this Section include, but are not necessarily limited to, General Conditions, Supplementary Conditions, and Division 01 – General Requirements of these Specifications.
  - 2. Section 32 10 00.13 "Roads, Driveways, and Walks".

## 1.2 QUALITY ASSURANCE

- A. Use adequate numbers of skilled workmen who are thoroughly trained and experienced in the necessary crafts and who are completely familiar with the specified requirements and the methods needed for proper performance of the work of this Section.
- B. Use equipment adequate in size, capacity, and numbers to accomplish the work in a timely manner.
- C. Comply with requirements of governmental agencies having jurisdiction.

## PART 2 - PRODUCTS

## 2.1 (As specified in Part 3)

## PART 3 - EXECUTION

## 3.1 GENERAL CONSTRUCTION REQUIREMENTS

- A. Strip topsoil and stockpile for use with final grading.
- B. Construct to the lines and grades as shown on the Drawings.

- C. Use excess excavated materials for embankment in areas as shown on the Drawings and as directed by the Engineer.

### 3.2 CLEARING, TREE REMOVAL, AND HEDGE REMOVAL

- A. Description:
  - 1. These items consist of the removal and disposal of all obstructions, such as fences, walls, foundations, buildings, accumulations of rubbish of whatever nature and existing structures, logs, shrubs, brush, and other vegetation; the cutting, grubbing, removal and disposal of all trees and stumps.
- B. Perform these items of work within the right of way, of excavation, and as directed by the Engineer in accordance with Section 201 of the WDOT "Standard Specifications".

### 3.3 ROADWAY EXCAVATION

- A. Description:
  - 1. Roadway excavation consists of excavation, removal and satisfactory disposal of all materials including pavement, taken from within the right of way for the construction of embankments, subgrade, sub-base, shoulders, intersections, ditches, waterways, and incidental work.
  - 2. Roadway excavation does not include excavation for structures, subgrade, or rock excavation.
- B. Perform roadway excavation in accordance with Section 205 of the WDOT "Standard Specifications".
  - 1. Terminate excavation with a full depth sawcut and provide a smooth vertical surface between the existing to be removed and the existing to remain as directed by the Engineer.

### 3.4 EMBANKMENT

- A. Description:
  - 1. This work consists of the construction of embankments by depositing, placing and compacting earth, stone, gravel, or other materials of acceptable quality above the existing grade.
- B. Comply with applicable articles of Section 207 of the WDOT "Standard Specifications".

### 3.5 BORROW

- A. Description:
  - 1. This work consists of obtaining embankment material from locations furnished by the Contractor or from borrow pits furnished by the Owner. It

includes excavating, transporting, and placing the material for the construction of embankments, subgrade, shoulders, sub-base, intersections, approaches, entrances, and other parts of the project as shown on the Drawings and directed by the Engineer.

- B. Comply with applicable articles of Section 208 of the WDOT "Standard Specifications".

### 3.6 SUBGRADE

- A. Description:

1. This work consists of preparing the subgrade including shaping and final compaction of the earth for the construction of sub-base, base, and surface course.

- B. Comply with applicable articles of Section 211 of the WDOT "Standard Specifications".

- C. Proof-roll the prepared subgrade for structural acceptance before pavement construction:

1. Provide 55,000-pound load on a rubber-tired, single-unit truck.
2. Drive slowly over area to be inspected.
3. Repair areas which show depressions or deflections greater than 1-inch deep.
  - a. Remove and dispose unsuitable material from failed area no more than 2 feet below proposed subgrade unless otherwise directed by Engineer.
  - b. Backfill excavation with material meeting the approval of Engineer or breaker run materials as specified in Section 311 of the WDOT "Standard Specifications".
  - c. Provide and install geotextile fabrics where directed by the Engineer.
    - (1) Comply with Section 645.2.5, Geotextile Fabric, Type SR (Subgrade Reinforcement) of the WDOT "Standard Specifications".
4. Repeat proof-roll and/or repair until approved by the Engineer.

END OF SECTION

SECTION 31 23 39

EXCAVATING, BACKFILLING, AND COMPACTING

PART 1 - GENERAL

1.1 SUMMARY

- A. Excavate, backfill, compact, and grade the site to the elevations shown on the Drawings, as specified herein, and as needed to meet the requirements of the construction shown in the Contract Documents.
- B. Related work:
  - 1. Documents affecting work of this Section include, but are not necessarily limited to, General Conditions, Supplementary Conditions, and Division 01 – General Requirements of these Specifications.

1.2 QUALITY ASSURANCE

- A. Use adequate numbers of skilled workmen who are thoroughly trained and experienced in the necessary crafts and who are completely familiar with the specified requirements and the methods needed for proper performance of the work of this Section.
- B. Use equipment adequate in size, capacity, and numbers to accomplish the work of this Section in a timely manner.
- C. Comply with requirements of governmental agencies having jurisdiction.

1.3 DELIVERY, STORAGE, AND HANDLING

- A. Comply with pertinent provisions of Section 01 66 11.

PART 2 - PRODUCTS

2.1 FILL AND EXCAVATED BACKFILL MATERIALS

- A. Provide excavated backfill materials free from organic matter, rubble, or frozen material, containing no rocks or lumps over 6 inches, and with not more than 15 percent of the rocks or lumps larger than 2 inches.
- B. Fill material is subject to the approval of the Engineer, and is that material removed from excavations or imported from off-site borrow areas, predominantly granular, non-expansive soils free from organic matter and other foreign matter.

EXCAVATING, BACKFILLING, AND COMPACTING

31 23 39-1 (150826.40)



- C. Do not permit rocks having a dimension greater than 1-inch in the upper 12 inches of fill or embankment.

## 2.2 TOPSOIL

- A. Topsoil is specified under Section 32 92 00.13 of these Specifications.
- B. Obtain topsoil from sources within the project limits, or provide imported topsoil obtained from sources outside the project limits, or from both sources.

## 2.3 STRUCTURAL BACKFILL MATERIAL

- A. Provide well graded, 100 percent crushed gravel or crushed stone aggregate free of clay, loam, dirt, calcareous or other foreign matter, conforming to the Section 210 of the WDOT "Standard Specifications" with the following gradation:

<u>Sieve Size</u>	<u>Percent Passing</u>
3.0-inch	100%
No. 4	Not less than 25%
No. 200	Not more than 15%

## PART 3 - EXECUTION

### 3.1 SURFACE CONDITIONS

- A. Examine the areas and conditions under which work of this Section will be performed. Correct conditions detrimental to timely and proper completion of the Work. Do not proceed until unsatisfactory conditions are corrected.

### 3.2 GENERAL CONSTRUCTION REQUIREMENTS

- A. Protection of existing facilities, persons, and property:
  1. Unless shown to be removed, protect existing structures, conduits, active utility lines and all other facilities shown on the Drawings or otherwise made known to the Contractor. If damaged, repair or replace to a condition equal to or better than the original condition at no additional cost to the Owner.
  2. Notify all persons, firms, corporations, or agencies owning or using any existing structures, conduits, or utilities which may be affected by the Work prior to the start of construction.
  3. Make arrangements to locate, maintain, protect, and/or relocate facilities in order to complete the Work.
  4. If existing utilities are found to interfere with the permanent facilities being constructed under this Section, immediately notify the Engineer and secure his instructions.
  5. Do not proceed with permanent relocation of utilities until written instructions are received from the Engineer.

## EXCAVATING, BACKFILLING, AND COMPACTING

31 23 39-2 (150826.40)

6. Barricade open holes and depressions occurring as part of the Work, and post warning lights on property adjacent to or with public access.
  7. Operate warning lights during hours from dusk to dawn each day and as otherwise required.
  8. Protect structures, utilities, sidewalks, pavements, and other facilities from damage caused by settlement, lateral movement, washout, and other hazards created by operations under this Section.
- B. Dewatering:
1. Remove all water, including rain water, encountered during trench and substructure work to an approved location by pumps, drains, and other approved methods.
  2. Keep excavations and site construction area free from water.
    - a. Whenever during construction operations any loose material is deposited in the flow line of gutters, drainage structures, or ditches such that the natural flow line of water is obstructed, remove this loose material at the close of each working day. At the conclusion of construction operations, keep all drainage structures and flow lines free from dirt and debris.
- C. Use means necessary to prevent dust becoming a nuisance to the public, to neighbors, and to other work being performed on or near the site.
- D. Maintain access to adjacent areas at all times.

### 3.3 EXCAVATING

- A. Perform excavating of every type of material encountered within the limits of the Work to the lines, grades, and elevations indicated and specified herein.
- B. Satisfactory excavated materials:
1. Transport to, and place in, fill or embankment areas within the limits of the Work.
- C. Unsatisfactory excavated materials:
1. Excavate to a distance below grade as directed by the Engineer, and replace with satisfactory materials.
  2. Include excavation of unsatisfactory materials, and replacement by satisfactory materials, as parts of the work of this Section.
- D. Surplus materials:
1. Dispose of unsatisfactory excavated material, and surplus satisfactory excavated material, away from the site at disposal areas arranged and paid for by the Contractor.

### EXCAVATING, BACKFILLING, AND COMPACTING

31 23 39-3 (150826.40)

- E. Topsoil materials:
  - 1. Strip and stockpile topsoil materials from areas to be excavated and regraded for use in final grading.
- F. Excavate and backfill in a manner and sequence that will provide proper drainage at all times.
- G. Borrow:
  - 1. Obtain material required for fill or embankment in excess of that produced within the grading limits of the Work from borrow areas selected and paid for by the Contractor and approved by the Engineer.
- H. Ditches and gutters:
  - 1. Cut accurately to the cross sections, grades, and elevations shown.
  - 2. Maintain excavations free from detrimental quantities of leaves, sticks, trash, and other debris until completion of the Work.
  - 3. Dispose of excavated materials as shown on the Drawings or directed by the Engineer; except do not, in any case, deposit materials less than 3'-0" from the edge of a ditch.
- I. Unauthorized excavation:
  - 1. Unauthorized excavation consists of removal of materials beyond indicated subgrade elevations or dimensions without specific instruction from the Engineer.
  - 2. Under footings, foundations, or retaining walls:
    - a. Fill unauthorized excavations by extending the indicated bottom elevation of the footing or base to the excavation bottom, without altering the required top elevation.
    - b. When acceptable to the Engineer, lean concrete fill may be used to bring the bottom elevation to proper position.
  - 3. Elsewhere, backfill and compact unauthorized excavations as specified for authorized excavations, unless otherwise directed by the Engineer.
- J. Stability of excavations:
  - 1. Slope sides of excavations to 1:1 or flatter, unless otherwise directed by the Engineer.
  - 2. Shore and brace where sloping is not possible because of space restrictions or stability of the materials being excavated.
  - 3. Maintain sides and slopes of excavations in a safe condition until completion of backfilling.
- K. Sheeting and bracing:
  - 1. Design, provide, and install sheeting and bracing as may be necessary for safety of personnel, protection of work, and compliance with requirements of governmental agencies having jurisdiction.
  - 2. Maintain sheeting and bracing in excavations regardless of the time period excavations will be open.

3. Remove sheeting and bracing after the excavation has been backfilled to an elevation which will prevent caving of exposed sidebanks.
4. Fill voids left by the withdrawal of sheeting with compacted sand.
5. Leave sheeting and bracing in place whenever necessary to protect adjacent facilities or property.

L. Excavating for structures:

1. Conform to elevations and dimensions shown within a tolerance of 0.10 ft, and extending a sufficient distance from footings and foundations to permit placing and removing concrete formwork, installation of services, other construction required, and for inspection.
2. In excavating for footings and foundations, take care not to disturb bottom of excavation:
  - a. Excavate by hand tools to final grade just before concrete is placed.
  - b. Trim bottoms to required lines and grades to leave solid base to receive concrete.
3. Excavate for footings and foundations only after general site excavating, filling, and grading are complete.
4. Minimum soil bearing capacity: 2500 psf or as otherwise required on the Drawings.

M. Excavating for pavements:

1. Cut surface under pavements to comply with cross sections, elevations, and grades.

N. Cold weather protection:

1. Protect excavation bottoms against freezing when atmospheric temperature is less than 35 degrees F.

### 3.4 FILLING AND BACKFILLING

A. General:

1. For each classification listed below, place acceptable soil material in layers to required subgrade elevations.
2. In excavations:
  - a. Use satisfactory excavated backfill or borrow fill materials.
3. Under concrete or bituminous pavements:
  - a. Use subbase materials as specified under Section 32 10 00.13 of these Specifications.
4. Under slabs, footings, conduits and other structures and facilities:
  - a. Use structural backfill material.

B. Backfill excavations as promptly as progress of the Work permits, but not until completion of the following:

1. Acceptance of construction below finish grade including, where applicable, dampproofing and water-proofing.

## EXCAVATING, BACKFILLING, AND COMPACTING

31 23 39-5 (150826.40)

2. Inspecting, testing, approving, and recording locations of underground utilities.
  3. Removing concrete formwork.
  4. Removing shoring and bracing, and backfilling of voids with satisfactory materials.
  5. Removing trash and debris.
  6. Placement of horizontal bracing on horizontally supported walls.
- C. Ground surface preparation:
1. Remove vegetation, debris, unsatisfactory soil materials, obstructions, and deleterious matter from ground surface prior to placement of fills.
  2. Plow, strip, or break up sloped surfaces steeper than one vertical to four horizontal so that fill material will bond with existing surface.
  3. When existing ground surface has a density less than that specified under "compacting" for the particular area, break up the ground surface, pulverize, moisture condition to the optimum moisture content, and compact to required depth and percentage of maximum density.
- D. Placing and compacting:
1. Place excavated backfill and fill materials in layers not more than 12 inches in loose depth.
  2. Place structural granular material in layers not more than 6 inches in loose depth.
  3. Compact each layer to the required density for the area.
  4. Do not place backfill or fill material on surfaces that are muddy, frozen, or containing frost or ice.
  5. Place backfill and fill materials evenly adjacent to structures, to required elevations.
  6. Take care to prevent wedging action of backfill against structures by carrying the material uniformly around the structure to approximately the same elevation in each lift.
  7. Where the construction includes basement or other underground walls having structural floors over them, do not backfill such walls until the structural floors are in place and have attained sufficient strength to support the walls.
  8. Compact each layer of structural backfill material with vibratory rollers, pneumatic tampers, or other compacting equipment approved by the Engineer.

### 3.5 GRADING

- A. General:
1. Uniformly grade the areas within limits of grading under this Section, including adjacent transition areas.
  2. Smooth the finished surfaces within specified tolerance.
  3. Compact with uniform levels or slopes between points where elevations are shown on the Drawings, or between such points and existing grades.

#### EXCAVATING, BACKFILLING, AND COMPACTING

31 23 39-6 (150826.40)

- B. Grading around structures:
  1. Grade areas adjacent to structures to achieve drainage away from the structures, and to prevent ponding.
  2. Finish the surfaces to be free from irregular surface changes, and:
    - a. Shape the surface of areas scheduled to be under walks to line, grade, and cross-section, with finished surface not more than 0.10 ft above or below the required subgrade elevation.
    - b. Shape the surface of areas scheduled to be under pavement to line, grade, and cross-section, with finished surface not more than 0.05 ft above or below the required subgrade elevation.

### 3.6 COMPACTING REQUIREMENTS

- A. Control soil compaction during construction to provide the minimum percentage of density specified for each area as determined according to ASTM D1557 or AASHTO T-180.
- B. Provide not less than the following maximum density of soil material compacted at optimum moisture content for the actual density of each layer of soil material in place, and as approved by the Engineer.
  1. Structures:
    - a. Compact the top 8 inches of subgrade and each layer of fill material or backfill material at 95 percent of maximum density.
  2. Lawn and unpaved areas:
    - a. Compact the top 8 inches of subgrade and each layer of fill material or backfill material at 85 percent of maximum density.
    - b. Compact the upper 12 inches of filled areas, or natural soils exposed by excavating, at 85 percent of maximum density.
  3. Walks:
    - a. Compact the top 8 inches of subgrade and each layer of fill material or backfill material at 90 percent of maximum density.
  4. Pavements:
    - a. Compact the top 8 inches of subgrade and each layer of fill material or backfill material at 90 percent of maximum density.
- C. Moisture control:
  1. Where subgrade or layer of soil material must be moisture-conditioned before compacting, uniformly apply water to surface of subgrade or layer of soil material to prevent free water appearing on surface during or subsequent to compacting operations.
  2. Remove and replace, or scarify and air dry, soil material that is too wet to permit compacting to the specified density.
  3. Soil material that has been removed because it is too wet to permit compacting may be stockpiled or spread and allowed to dry. Assist drying by discing, harrowing, or pulverizing.

### 3.7 MAINTENANCE

- A. Protection of newly graded areas:
  - 1. Protect newly graded areas from traffic and erosion, and keep free from trash and weeds.
  - 2. Repair and reestablish grades in settled, eroded, and rutted areas to the specified tolerances.
  
- B. Where completed compacted areas are disturbed by subsequent construction operations or adverse weather, scarify the surface, reshape, and compact to the required density prior to further construction.

END OF SECTION

## SECTION 31 23 79

## TRENCHING, BACKFILLING, AND COMPACTING

## PART 1 - GENERAL

## 1.1 SUMMARY

- A. Trench, backfill, and compact as specified herein and as needed for installation of underground pipelines and utilities associated with the Work.
- B. Related work:
  - 1. Documents affecting work of this Section include, but are not necessarily limited to, General Conditions, Supplementary Conditions, and Division 01 – General Requirements of these Specifications.
- C. References:
  - 1. The following detailed Specifications for Trenching, Backfilling, and Compacting shall govern where they alter/or add to the requirements and specifications set forth in the Standard Specifications for Sewer and Water Construction in Wisconsin, latest edition and the Wisconsin Department of Transportation Standard Specifications for Highway and Structure Construction, latest edition.

## 1.2 SUBMITTALS

- A. Shop Drawing Submittals – None Required.
- B. Operation and Maintenance Manuals – None Required.
- C. Certificates and Guarantees – None Required.
- D. Lubricants – None Required.
- E. Spare Parts – None Required.

## 1.3 QUALITY ASSURANCE

- A. Use adequate numbers of skilled workmen who are thoroughly trained and experienced in the necessary crafts and who are completely familiar with the specified requirements and the methods needed for proper performance of the work of this Section.
- B. Use equipment adequate in size, capacity, and numbers to accomplish the work in a timely manner.
- C. Comply with requirements of governmental agencies having jurisdiction.

## TRENCHING, BACKFILLING, AND COMPACTING

31 23 79-1 (150826.40)



## 1.4 DELIVERY, STORAGE, AND HANDLING

- A. Comply with pertinent provisions of Section 01 66 11.

## 1.5 SITE CONDITIONS – Reserved.

## 1.6 MAINTENANCE – Reserved.

# PART 2 - PRODUCTS

## 2.1 GRANULAR PIPE BEDDING AND COVER MATERIALS

- A. Provide well graded, washed, mixture of 100 percent crushed gravel or crushed stone aggregate free of clay, loam, dirt, calcareous or other foreign matter conforming to the "Standard Specifications for Sewer and Water Construction in Wisconsin", and City of Madison Water Utility Standard Details Drawing No. 701.

1. For pipe 18 inches in diameter and smaller, use material of 3/8-inch crushed stone chips with the following gradation:

<u>Sieve Size</u>	<u>Percent Passing By Weight</u>
1/2-inch	100%
3/8-inch	90-100%
No. 8	0-15%
No. 30	0-3%

2. For water mains with polyethylene wrap, use sand consisting of durable particles ranging in size from fine to coarse in a substantially uniform combination.

- a. Acceptable alternatives: Unwashed bank-run sand, rejected concrete sand, and crushed bank-run gravel.
- b. Include approximately 6 percent of fine clay or loam particles; do not allow clay or loam lumps.
- c. Moisture content: 10 percent maximum.
- d. Gradation requirements:

<u>Sieve Size</u>	<u>Percent Passing By Weight</u>
1-inch	100%
No. 16	45-80%
Material finer than No. 200	2-10%

3. For flexible thermoplastic pipes: Comply with ASTM D2321, Class I or II as modified below:

- a. Exclude sharp angular granular materials.
- b. Limit maximum particle size to 1/2-inch.
- c. Do not use Class II materials in wet conditions.

4. For rigid pipes comply with ASTM C12, Bedding Class B.

## 2.2 EXCAVATED BACKFILL MATERIALS

- A. Provide soil materials free from organic matter, rubble, or frozen material, containing no rocks or lumps over 6 inches, and with not more than 15 percent of the rocks or lumps larger than 2 inches.

# TRENCHING, BACKFILLING, AND COMPACTING

31 23 79-2 (150826.40)

2.3 GRANULAR BACKFILL

A. Provide either sand, pit run gravel, granular material, or excavated granular materials.

- 1. Sand: Well graded, free from organic matter, cohesionless, complying with the "Standard Specifications for Sewer and Water Construction in Wisconsin" with the following gradation:

<u>Sieve Size</u>	<u>Percent Passing By Weight</u>
1-inch	100%
No. 16	45-80%
Material finer than No. 200	2-10%

- 2. Pit run gravel: Free from organic matter, cohesionless granular material obtained from natural deposits of sand and gravel, passing 3/4-inch sieve, and not more than 15 percent passing the No. 200 sieve.
- 3. Granular material: Use granular materials consisting of durable particles ranging in size from fine to coarse in a substantially uniform combination complying with the "Standard Specifications for Sewer and Water Construction in Wisconsin" with the following gradation:

<u>Sieve Size</u>	<u>Percent Passing By Weight</u>
2-inch	95-100%
No. 4	35-60%
Finer than No. 200	5-15%

- 4. Excavated granular materials: A mixture of sand and gravel, free from organic matter, clay, loam, dirt, and other foreign material, passing the 1 1/2-inch sieve, with not more than 15 percent passing the No. 200 sieve.
- 5. No. 2 Crushed stone: Clean, hard, tough, durable, angular material crushed from bedrock limestone, dolomite, or granite.

a. Gradation requirements:

<u>Sieve Size</u>	<u>Percent Passing By Weight</u>
3-inch	100%
2 1/2-inch	90-100%
2-inch	35-70%
1 1/2-inch	0-15%
3/4-inch	0-5%

2.4 LEAN CONCRETE MIX BACKFILL

A. Provide lean concrete mix backfill, thoroughly mixed in a concrete mixer truck complying with the "Standard Specifications for Sewer and Water Construction in Wisconsin".

2.5 GEOTECHNICAL FABRIC

A. Provide geotechnical fabric for separation of granular material and native soil in areas where trench is overexcavated to remove unsuitable materials.

- 1. Acceptable manufacturers:
  - a. Mirafi: 160N.
  - b. Synthetic Industries: 601.
  - c. Amaco: 4551.

## PART 3 - EXECUTION

### 3.1 SURFACE CONDITIONS

- A. Examine the areas and conditions under which work of this Section will be performed. Correct conditions detrimental to timely and proper completion of the Work. Do not proceed until unsatisfactory conditions are corrected.

### 3.2 GENERAL CONSTRUCTION REQUIREMENTS

- A. Protection of existing facilities:
  - 1. Unless shown to be removed, protect existing structures, conduits, active utility lines and all other facilities shown on the Drawings or otherwise made known to the Contractor. If damaged, repair, replace, or restore to a condition equal to or better than the original condition at no additional cost to the Owner.
  - 2. Notify all persons, firms, corporations, or agencies owning or using any existing structures, conduits, or utilities which may be affected by the Work prior to the start of construction.
  - 3. Make arrangements to locate, maintain, protect, and/or relocate facilities in order to complete the Work.
  - 4. Make such exploration as is necessary to determine the exact location of underground utilities.
  - 5. Exercise care during the progress of work in the area to prevent damage to the utilities.
  - 6. Whenever it becomes necessary to relocate underground gas mains, telephone conduit, or electrical lines, the utility company involved will make such relocation. Notify the utility company promptly.
  - 7. Whenever it becomes necessary to relocate water or other pipes or conduits in direct conflict with the proposed pipe (exclusive of culverts) which are not shown on the Drawings, obtain the direction from the Engineer for the relocation. Compensation will be allowed only for such quantities as directed by the Engineer.
  - 8. Do not block or obstruct sidewalks, streets, and pavements.
  - 9. Whenever during construction operations any loose material is deposited in the flow line of gutters, drainage structures, or ditches such that the natural flow line of water is obstructed, remove this loose material at the close of each working day. At the conclusion of construction operations, keep all drainage structures and flow lines free from dirt and debris.
  - 10. Do not obstruct accessibility of fire hydrants.
  - 11. Maintain access to adjacent areas at all times.
- B. Protection of Trees and Shrubs:
  - 1. Protect trees and shrubs from damage.
  - 2. Provide exhaust deflectors or other devices for machinery as required to prevent damage to trees and shrubs from exhaust gases.
  - 3. Do not remove trees or shrubs unless indicated on the Drawings or authorized in the field by the Engineer.

4. Where trees which are to remain interfere with normal excavation operations, use the following procedures:
    - a. Prior to excavation, carefully remove trees with trunk diameters of less than 4 inches, shrubs, and other plantings in the way of construction.
    - b. Do not machine excavate within a distance of three trunk diameters or 12 inches (whichever is greater) of any tree, and do not cut roots over 2-inch diameter unless approved by the Engineer.
    - c. Excavate by hand when closer than three tree trunk diameters or 12 inches (whichever is greater).
    - d. Tree tunneling where necessary to be determined by the Engineer.
    - e. Tie back shrubs and tree limbs to prevent loss or damage.
    - f. Prune and seal damaged limbs and branches.
    - g. Provide plank wrappers wired in place to protect tree trunks from being damaged by trench machinery, tractors, or trucks; remove protective planking as soon as practical after work in vicinity has been completed.
    - h. Remove spoil banks from around trees by hand to prevent damage to trunks by construction machinery.
  5. Replace trees and shrubs which cannot be protected or are damaged during construction:
    - a. Replant or replace with stock of like character, quality, variety, size, shape, color and condition upon completion of the construction.
    - b. Replace 4-inch diameter and larger trees with one 4-inch diameter size tree for each 6 inches of original tree diameter or fraction thereof.
    - c. Replace trees smaller than 4-inch diameter and shrubs with same kind and type.
    - d. As an option, replant trees smaller than 2-inch diameter or shrubs which are not damaged.
  6. Remove and replace trees and shrubs which do not survive in good condition for a period of 18 months after time of planting.
- C. Work on private property:
1. Construct work on private property within easements obtained by the Owner as shown on the Drawings.
    - a. The Contractor will be permitted construction privileges within construction easement lines as shown on the Drawings.
    - b. Perform the work in a manner such as to minimize damage to lawns, shrubs, trees and other plantings, driveways, sidewalks, fences, outbuildings, and any other miscellaneous improvements, using proper size and type of equipment.
    - c. The Engineer has the authority to prohibit the use of any equipment which in his judgment is too large or otherwise unsuitable for the conditions of the work on private property.
  2. Remove and replace fences, outbuildings and other miscellaneous improvements in the way of construction to the satisfaction of the property owner.

3. When working in cultivated fields or gardens, remove original topsoil to a depth of 12 inches prior to excavation, and replace the topsoil to its original depth and grade upon completion of trench backfill.
4. Restore the private property to its original condition or better, free of debris, stones and excess materials.

### 3.3 TRENCHING

- A. Do not advance trench excavation more than 50 feet ahead of completed pipe installation except as approved by the Engineer.
- B. Provide and maintain sheeting, shoring, and bracing necessary for protection of the Work, adjacent property, and for the safety of personnel.
  1. Remove temporary sheeting and bracing after backfilling to an elevation which will prohibit caving of exposed sidebanks.
  2. Fill voids left by the withdrawal of sheeting with compacted sand.
  3. The Engineer may direct that supports in trenches be cut off at any specific elevation to protect adjacent facilities or property. Compensation for support left in place will be negotiated.
  4. No extra payment will be made for the supports left in place without the direction of the Engineer.
  5. Do not leave supports within 4 feet of the ground or pavement surface in place without the permission of the Engineer.
- C. Provide pumping, bailing, wellpointing, and construct ditches and dikes required to dewater and drain ground water, sewage, or storm water to keep the excavation and site dry for the completion of the Work.
- D. Excavation:
  1. Excavate by open cut unless otherwise indicated on the Drawings.
  2. Excavate trenches to the depths and grades necessary for the pipelines with allowances for bedding material.
    - a. Comply with the following minimum depth of cover unless otherwise noted on the Drawings:  
 Water pipelines: 6 feet.  
 Sewage and sludge pressure piping: 5 feet.  
 Air and gas piping: 3 feet.  
 Electrical or wiring conduits and cables: 30 inches.
  3. Overexcavate organic, soft, spongy, or otherwise unsuitable soils found at or below the bottom of the trench to meet firm subsoil or as directed by the Engineer.
  4. Comply with the following maximum trench widths at the top of pipelines:
 

<u>Nominal Pipe Sizes (Inches)</u>	<u>Trench Widths (Inches)</u>
12 or smaller	30
14-18	36
20-24	42
27-30	48
33 and larger	1-1/3 times pipe O.D.

5. Where the trench width exceeds the maximum limitations, provide higher strength pipe, or embed or cradle the pipe in concrete to achieve the necessary load factor as determined by the Engineer at no additional cost to the Owner.

### 3.4 EXCAVATION FOR APPURTENANCES

- A. Excavate for manholes and similar structures to the depths as shown on the Drawings and to a distance sufficient to leave at least 12 inches clear between outer surfaces and the embankment or shoring that may be used to hold and protect the banks.
- B. Overdepth excavation beyond depths indicated on the Drawings that has not been directed will be considered unauthorized. Fill with sand, gravel, or lean concrete as directed by the Engineer, and at no additional cost to the Owner.

### 3.5 BEDDING AND COVERING OF PIPE

- A. General:
  1. Bedding is defined as the shaped and tamped material which supports the pipes. Covering is defined as the compacted material which protects and covers the pipes.
  2. Provide continuous bedding and covering for underground pipelines, except where concrete encasement, concrete cradles, boring or jacking are indicated.
- B. Pipe bedding:
  1. Provide compacted granular pipe bedding and covering material with a minimum thickness of 4 inches under pipe barrels and 2 inches under bells.
  2. Wherever the trench is overexcavated due to the removal of unsuitable material, refill the excavated area to the bottom of the pipe bedding with No. 2 crushed stone or granular material conforming to the Granular Backfill Materials gradation as indicated in the "Open Cut Pipeline Installation Unsuitable Material Removal/Replacement Detail".
    - a. Removal and replacement of material, or unsuitable material, to a depth of one foot below the bottom of the pipe barrel is considered incidental to installation of the pipe.
  3. Wherever the trench is overexcavated to remove unsuitable material, install geotechnical fabric between native soil and granular material:
    - a. Install fabric to cover bottom and sides of trench to heights as follows:
      - (1) Sanitary sewer, force main, and water main: to envelope entire bedding and covering material and overlap 1-foot at the top.
      - (2) Storm sewer: to cover bedding material and from sides of trench to edge of pipe.
      - (3) Where undercut is of a depth that requires more than one piece of fabric to provide envelope, provide sewn seams between sections of fabric.

## TRENCHING, BACKFILLING, AND COMPACTING

31 23 79-7 (150826.40)

4. Wherever two or more pipes or conduits are placed in the same trench or excavated area, backfill the trench with granular pipe bedding and covering material to support the uppermost pipe or conduit.
5. Provide sand bedding with a minimum thickness of 3 inches under electrical and wiring conduits and cables.

C. Pipe covering:

1. Following placement of pipe and inspection of joints, provide compacted granular pipe bedding and covering material for the full width of the trench to the following levels unless otherwise shown on the Drawings:
  - a. For pipes sizes 24-inch and smaller, except flexible thermoplastic pipe: To 4 inches above the top of the pipe.
  - b. For pipes sizes 27-inch and larger, except flexible thermoplastic pipe: To the horizontal centerline of the pipe.
  - c. For flexible thermoplastic pipes: To 12 inches above the top of the pipe.
  - d. If compacted excavated materials are used for backfilling under the pavement as indicated on the Drawings: To 12 inches above the top of the pipe for all pipe sizes.
2. Place granular pipe bedding and covering material in uniform loose layers not exceeding 8 inches thick.
  - a. Compact each layer firmly by ramming or tamping with tools approved by the Engineer in such a manner as not to disturb or injure the pipe to yield a minimum density of 95 percent of maximum dry density as determined according to ASTM D1557 or AASHTO-T180.
3. Where trench is widened by installation of structures or jacking pits, extend bedding and covering materials to total width of excavation.

### 3.6 TRENCH BACKFILLING AND COMPACTING

A. General:

1. Backfill trench from the top of pipe cover to topsoil, paving subgrade, or foundation level.
2. If trenches settle during the period of construction and within the guarantee period of the work, fill trench back to the surrounding grade, and restore the surfaces.

B. For trench in lawns, parkways, and other improved areas not subject to vehicular traffic:

1. Backfill with excavated materials in uniform loose layer not exceeding 12 inches thick.
2. Compact each layer of trench backfill materials to yield a minimum of 85 percent of maximum dry density as determined according to ASTM D1557 or AASHTO-T180.

C. For trench in unimproved areas and cultivated fields:

1. Backfill with excavated materials.
2. Provide crowned surface to compensate for settlement.

### TRENCHING, BACKFILLING, AND COMPACTING

31 23 79-8 (150826.40)

- D. For trench in streets, parking areas, driveways, sidewalks, curb and gutter, or within 2 feet of any proposed curb and gutter, sidewalk, and other paved areas:
1. Backfilling with granular backfill materials:
    - a. Place in uniform loose layer not exceeding 12 inches thick and compact with vibrating roller or equivalent.
    - b. Fill the top of trenches with temporary aggregate pavement material to the depth(s) required to provide aggregate base and pavement base, binder and surface courses of the depth(s) shown in the Details in the Drawings.
  2. Compacting requirements:
    - a. Compact each layer of trench backfill materials to yield a minimum density of 90 percent of maximum dry density as determined according to ASTM D1557 or AASHTO T-180.
    - b. Determine the density of compacted backfill at intervals of not more than 500 feet at locations selected by the Engineer.
    - c. The Owner will provide the services of an independent testing laboratory for the density tests complying with the pertinent provisions of Section 01 45 29.
  3. Maintain temporary aggregate pavement level with adjoining pavement surfaces until the permanent pavement is placed.

### 3.7 BACKFILL AND BEDDING FOR APPURTENANCES

- A. Provide 3 inches of sand or granular bedding material unless otherwise shown on the Drawings.
- B. Do not backfill until new concrete has properly cured, and any required tests have been accepted.
- C. Backfill in lawns and landscaped areas with excavated materials.
- D. Backfill in pavement around manholes, catch basins, inlets, valve vaults, and other structures as directed by the Engineer with granular backfill materials.

### 3.8 FINISH GRADING

- A. General:
  1. Provide finish grading and filling to achieve the lines and grades.
  2. Slope grades to drain away from structures.
  3. Replace culverts damaged during the construction with new culverts as specified in Section 33 42 13 of the Specifications.
- B. Finish grading:
  1. Except where mounding over trenches is specified, grade smooth areas of the Work including previously grassed areas that have been disturbed, and adjacent transition areas.
  2. Fill and compact depressions from settlement and round tops of embankments and breaks in grade.



3. Protect newly graded areas from traffic and erosion. Repair settlement or washing away that may occur prior to surface restoration and re-establish grades to the required elevations at no additional cost to the Owner.

C. Disposal of waste excavated material:

1. Remove unsuitable and surplus excavated materials not used for backfilling from the project site.
2. Do not deposit on public or private property without written permission from property owner or authorized representative of appropriate public agency.

### 3.9 ROCK EXCAVATION

- A. Rock Excavation is not expected on this Project. If Rock is encountered it will need to be paid for through a negotiated Change Order.

- B. Rock excavation is classified as excavation requiring blasting or jack hammering to remove solid rock formations such as boulders, concrete, or solid masonry exceeding one cubic yard in volume.

C. Allowable trench width for open trench excavation:

1. For pipes up to 18 inches ID: 30 inches.
2. For larger pipes: The outside diameter of the pipe plus 8 inches.
3. Pipe bedding: 6 inches below the bottom of the pipe.
4. Manholes and similar structures not requiring formwork: 1-foot outside such structures.

- D. Lay pipelines constructed in trenches in rock to the grades shown on the Drawings on a continuous bed of compacted gravel or crushed stone.

1. Dispose of excavated rock; do not use as backfill.

E. Blasting:

1. Comply with rules and regulations of authorities having jurisdiction.
  - a. Issue signals of danger before firing a blast.
  - b. Do not blast adjacent to any portion of the completed work unless proper precautions are taken to protect the work.
  - c. Use only persons who are licensed as required by State or local regulations, and who are experienced in the techniques of blasting, to perform blasting operations.
2. Repair or reconstruct structures, pipelines, or other property damaged by blasting operations.

END OF SECTION

## SECTION 31 25 00

## SOIL EROSION AND SEDIMENT CONTROLS

## PART 1 - GENERAL

## 1.1 SUMMARY

- A. Provide soil erosion and sediment controls as shown on the Drawings, as specified herein, as required by the governmental authority, and as needed for a complete and proper installation.
- B. Related work:
  - 1. Documents affecting work of this Section include, but are not necessarily limited to, General Conditions, Supplementary Conditions, and Division 01 - General Requirements of these Specifications.
- C. Related documents:
  - 1. "Wisconsin Department of Natural Resources Storm Water Management Technical Standards" and "Conservation Practice Standards".
  - 2. Wisconsin Department of Transportation "Standard Specifications for Highway and Structure Construction", latest edition and "Erosion Control Product Acceptability List".
  - 3. City of Madison Standards

## 1.2 QUALITY ASSURANCE

- A. Provide adequate numbers of skilled workers who are thoroughly trained and experienced in the necessary crafts and who are completely familiar with the specified requirements and methods needed for proper performance of the work of this Section.
- B. Inspect all soil erosion and sediment control devices on a weekly basis and after rainfall events of ½-inch or greater. Provide a weekly inspection report.

## 1.3 DELIVERY, STORAGE, AND HANDLING

- A. Comply with pertinent provisions of Section 01 66 11.

## PART 2 - PRODUCTS

## 2.1 GENERAL

- A. Provide soil erosion and sediment controls in accordance with the requirements of the City of Madison, Wisconsin Department of Natural Resources and the Wisconsin Department of Transportation (WDOT) "Standard Specifications".
- B. Provide manufacturer's certification that product meets the minimum specified standard, if requested by the Engineer.

## SOIL EROSION AND SEDIMENT CONTROLS

31 25 00-1 (150826.40)

## 2.2 TEMPORARY EROSION AND SEDIMENT CONTROL SYSTEMS

- A. Construction Entrance:
1. Construction Entrance can be constructed out of 3-inch clear or washed stone, minimum 12 inches thick and underlain by WDOT Type HR or FF Geotextile fabric. Construction Entrance dimensions and other requirements shall comply with City of Madison Standard Detail Drawing 1.07.
- B. Rolled Erosion Control Products:
1. Material: Products consisting primarily of totally encased straw or excelsior that comply with WDOT Erosion Control Product Acceptability List for Temporary Ditch Checks.
  2. Stakes: As recommended by manufacturer.
- C. Straw bale barrier:
1. Material: Clean, weed-free straw, or similar material, from agricultural crops.
  2. Bales: Compacted, tightly bound with twine only, not wire.
  3. Bale stakes: 1/2-inch diameter steel, or 1-inch diameter wood.
    - a. Length: 4 feet minimum.
- D. Silt fence:
1. Material: Comply with WDOT Standard Specification 628.
  2. Support posts and other hardware: Comply with WDOT Standard Specification 628.
- E. Ditch check:
1. Ditch checks can be constructed out of stone, rock bags, double row of straw bales or WDOT-approved engineered products. Materials are described in WDNR Ditch Check Conservation Practice Standard and WDOT Standard Specification Section 628. Stone berm ditch checks shall match City of Madison Standard Detail Drawing 1.05.
- F. Temporary cover:
1. Comply with Section 32 92 00.13 of these Specifications for purity and germination.
  2. Seed: Annual rye, spring oats, or wheat.
- G. Temporary riprap:
1. Comply with WDOT, Section 606.
- H. Compost filter log:
1. Provide compost filter logs consisting of a compost/wood chip blend material placed inside a geotextile bag, and held in place with wood support posts/stakes.
    - a. Logs shall be minimum 12" diameter, unless otherwise shown on Drawings.
  2. Provide compost/wood chip blend consisting of 40 - 100% weed free compost and 0-60% partially decomposed wood chips. The

- compost/wood chip blend material shall pass a 2-inch sieve with a minimum of 70% retained on a 3/8-inch sieve.
3. Provide geotextile bags consisting of a knitted material with openings of 3/8 inches to contain the compost/wood chip material, but not limiting water infiltration.
  4. Provide compost material meeting the following requirements:
    - a. Particle Size: 98 percent passing a 0.75-inch screen.
    - b. Physical Contaminants: Less than 1 percent combined glass, metal, and plastic.
    - c. Organic Matter/Ash Content: At least 40 percent organic matter and less than 60 percent ash content.
    - d. Carbon to Nitrogen Ratio: 10:1 to 20:1 C:N ratio.
    - e. pH: Between 6 and 8.
    - f. Soluble Salts: Electrical conductivity below 10 dS m<sup>-1</sup> (mmhos cm<sup>-1</sup>).
    - g. Moisture Content: Between 35 and 50 percent by weight.
    - h. Maturity: Compost shall be resistant to further decomposition and free of compounds, such as ammonia and organic acids, in concentrations toxic to plant growth.
    - i. Residual Seeds and Pathogens: Noxious seeds and pathogens shall be minimized.
    - j. Other Chemical Contaminants: Meet WDNR land application requirements for compost and mulch.
    - k. A copy of the compost test results, verifying compliance with WDNR standards for Mulching For Construction Sites, shall be provided to the Engineer with each shipment of compost.
  5. Provide support posts consisting of wood stakes with minimum dimensions of 2-inch x 2-inch, with a minimum length of 28 inches for 12-inch diameter compost filter logs.
  6. Acceptable products:
    - a. Filtrex Silt Soxx.
    - b. Or equal.

### 2.3 EROSION MAT

- A. Provide WDOT-approved Erosion Mat as described in the Erosion Control Product Acceptability List and shown on the Drawings.
  1. Designer Note: Choose from the following list:
    - a. Class I:
      - (1) Type A.
      - (2) Type B.
      - (3) Urban Type A.
      - (4) Urban Type B.
- B. Hardware: Use staples and other hardware as described in WDOT Standard Specification Section 628.

## SOIL EROSION AND SEDIMENT CONTROLS

31 25 00-3 (150826.40)

## 2.4 RIPRAP

- A. Filter fabric:
  - 1. For Light Riprap, use Geotextile Fabric, Type R, and for Medium and Heavy Riprap, use Geotextile Fabric, Type HR, as specified in WDOT Section 645.
- B. Bedding material:
  - 1. Coarse aggregate conforming to WDOT "Standard Specifications" 3/4-Inch Dense Graded Base.
- C. Riprap:
  - 1. Conform to WDOT Section 606.
    - a. Medium Rip Rap.

## PART 3 - EXECUTION

### 3.1 PREPARATION

- A. Install soil erosion and sediment controls prior to any other construction and maintain until site is stabilized.
- B. Prepare subgrade for the installation of the soil erosion and sediment control systems to the lines and grades shown on the Drawings.
- C. Repair eroded or washed out areas prior to the installation of soil erosion and sediment control systems.

### 3.2 CONSTRUCTION ENTRANCE

- A. Install construction entrance where shown on the Drawings and as directed by the Engineer.
  - 1. Surface waters shall be prevented from passing through construction entrance.
  - 2. Clean by scraping or adding new stone if construction entrance becomes more than 50% covered by tracked mud.
  - 3. Remove upon completion of Work or as directed by Engineer.

### 3.3 ROLLED EROSION CONTROL PRODUCTS

- A. Install straw wattles or sediment logs where shown on the Drawings and as directed by the Engineer.
  - 1. Anchor each log by driving stakes through the ends and at 2-foot intervals.
  - 2. Inspect frequently and repair or replace as necessary.
  - 3. Remove upon completion of Work or as directed by Engineer.

### 3.4 STRAW BALE BARRIER

- A. Install straw bale barriers where shown on the Drawings and as directed by the Engineer.
  - 1. Place bales at the toe of the slope or on the contour in a row with ends tightly abutting the adjacent ends.

2. Embed each bale 4 inches, minimum.
3. Place bales such that bindings are horizontal.
4. Anchor each bale by driving two (2) stakes through the bale.
  - a. Drive the first stake in each bale towards the previously laid bale at an angle to force the bales together.
  - b. Drive stakes flush with the bale.
5. Inspect bales frequently and repair or replace as necessary.
6. Remove bales upon completion of Work or as directed by Engineer.

### 3.5 SILT FENCE

- A. Install silt fence where shown on the Drawings, in accordance with WDOT Standard Specification 628, and as directed by the Engineer.
  1. Perform maintenance as needed.
  2. Remove material when it reaches 1/3 of the fence height, and as directed by Engineer.
  3. Replace fence where it is torn or otherwise damaged.
  4. Retrench or replace fence that is not properly entrenched or anchored.
  5. Remove fence upon completion of Work, or as directed by Engineer.

### 3.6 DITCH CHECK

- A. Install ditch check where shown on the Drawings and as directed by the Engineer. Install in accordance with WDNR Ditch Check Conservation Practice Standard and WDOT Standard Specification 628.
  1. Maintain ditch check during course of the Work.
    - a. Remove trapped sediment.
    - b. Clean fabric periodically, and after each rainfall.
  2. Remove ditch check upon completion of Work, or as directed by Engineer.

### 3.7 TEMPORARY COVER

- A. Install temporary cover where shown on the Drawings, in accordance with pertinent provisions of Section 32 92 00.13 of these Specifications, particularly Article 32 92 00.13 3.4, and as directed by the Engineer.

### 3.8 EROSION MAT

- A. Install erosion mat where shown on the Drawings, in accordance with manufacturer's recommended installation procedures, and as directed by the Engineer.
- B. Immediately after rolling seeded area, place erosion mat on slopes steeper than 3 horizontal to 1 vertical. Or all seeded areas.
- C. Unless otherwise specified, place erosion mat at sides and bottoms of ditches, swales, and areas within 10 feet of catch basins in seeded areas.

### 3.9 RIPRAP

- A. Filter fabric:
  1. Install filter fabric as shown on the Drawings, in accordance with manufacturer's recommended installation procedures, and in accordance with WDOT Standard Specification 645.

## SOIL EROSION AND SEDIMENT CONTROLS

31 25 00-5 (150826.40)

2. Protect filter fabric from punching, cutting, or tearing.
  - a. Repair damage by placing another piece of fabric over the damaged area, or by completely replacing the fabric.
3. Overlap filter fabric a minimum of one (1) foot.

B. Riprap:

1. Install riprap where shown on the Drawings, in accordance with WDOT "Standard Specifications" Section 606, and as directed by the Engineer, except as modified herein.
2. Spread bedding material uniformly on filter fabric to neat lines as shown on the Drawings.
  - a. Place bedding material by methods that will not segregate particle sizes within the bedding.
  - b. Repair damage to bedding surface before proceeding with work.
  - c. Finish bedding material to an even surface free of mounds, windrows, or depressions.
3. Place riprap stone on the bedding layer to the lines and grades shown on the Drawings.
  - a. Provide minimum voids and maximum interlocking of rock.
  - b. Place the stone riprap to its full thickness in one operation.
  - c. Place stones at lower elevations first, then progress up the slope, and from the center outward.
  - d. Distribute larger stones evenly through the entire mass.
4. Use means necessary to remove accumulated sediment.

### 3.10 COMPOST FILTER LOG

- A. Install compost filter logs at locations shown, or as indicated by notes, on Drawings.
- B. Stake compost filter logs in place with wood support posts.
  1. Drive wood stakes through logs with at least 12 inches of the stake in the ground and 3 inches of the stake above the filter log. Install stakes every 5 feet along each log unless conditions warrant closer spacing.
    - a. Where more than one log is needed to achieve planned lengths, ends shall be overlapped at least 12 inches with both ends staked into place.
- C. Perform maintenance as needed. Remove collected silt or sediment when silt/sediment reaches one-half the height of filter log(s).
- D. Remove compost filter logs upon completion of Work or as directed by Engineer, unless logs to be incorporated into landscape. If compost filter logs are intended to be left as a permanent filter, or part of the natural landscape, seed the logs as part of permanent seeding requirements.

END OF SECTION

## SECTION 32 10 00.13

## ROADS, DRIVEWAYS, AND WALKS

## PART 1 - GENERAL

## 1.1 SUMMARY

- A. Provide roads, driveways, and walks as shown on the Drawings, as specified herein, and as needed for a complete and proper installation.
- B. Construct roads, driveways, and walks in accordance with the WDOT "Standard Specifications" and "Supplemental Specifications", except as herein modified.
- C. Related work:
  - 1. Documents affecting work of this Section include, but are not necessarily limited to, General Conditions, Supplementary Conditions, and Division 01 - General Requirements of these Specifications.

## 1.2 QUALITY ASSURANCE

- A. Source quality control:
  - 1. Comply with Section 106 of the WDOT "Standard Specifications".
  - 2. Submit certificates from source of aggregate materials that aggregate meets specified standards.
  - 3. Submit certificates from geotextile manufacturer that fabric meets specified standards.
  - 4. Obtain asphaltic mixtures and Portland Cement concrete from plants approved by the WDOT.
  - 5. Submit the name of the source of materials proposed for use on the Project to the Engineer at the Preconstruction Meeting.
  - 6. Submit WDOT mix designs for asphaltic surface plant mix, asphaltic concrete binder and surfaces courses, and Portland Cement concrete proposed to be constructed.
- B. Hot mix asphalt pavement quality management program:
  - 1. Comply with Section 460.2.8 of the WDOT "Standard Specifications".
  - 2. Comply with the pertinent provisions of Section 01 45 29.
- C. Concrete pavement testing and quality control:
  - 1. Provide the services of an independent testing laboratory for the following specified sampling and testing requirements:
    - a. Make beams or cylinders in accordance with Section 415 of the WDOT "Standard Specifications" and test the Portland Cement concrete pavement for flexural or compressive strength.
    - b. Take cores in accordance with Section 415 of the WDOT "Standard Specifications" and determine the thickness of the Portland Cement concrete pavement.
    - c. Comply with the pertinent provisions of Section 01 45 29.

## ROADS, DRIVEWAYS, AND WALKS

32 10 00.13-1 (150826.40)



## PART 2 - PRODUCTS

### 2.1 SUBBASE

- A. Breaker run materials:
  - 1. Use crushed stone or crushed concrete complying with Section 311 of the WDOT "Standard Specifications" for Breaker Run.

### 2.2 BASE COURSE

- A. Asphaltic base:
  - 1. Comply with Section 315 of the WDOT "Standard Specifications" for materials and material preparation.
- B. Concrete base:
  - 1. Comply with Section 320 of the WDOT "Standard Specifications" for materials and material preparation.

### 2.3 TACK COATS

- A. Asphaltic materials:
  - 1. Comply with types shown in Section 455.2.5 of the WDOT "Standard Specifications".

### 2.4 SURFACE COURSE

- A. Asphaltic surface:
  - 1. Comply with Section 465 of the WDOT "Standard Specifications" Type (E-0.3). Conform to the following nominal size of aggregate in the mixture:
    - a. Use 12.5 mm (1/2") for binder and surface course each layer being of 1-3/4" thickness for a 3-1/2" total asphalt thickness.

### 2.5 SHOULDERS

- A. Aggregate:
  - 1. Use crushed stone or crushed gravel complying with Section 305 of the WDOT "Standard Specifications", 3/4-inch dense graded base.

### 2.6 CONCRETE SIDEWALK AND APPROACH SLABS

- A. Comply with Section 602 of the WDOT "Standard Specifications".
- B. Concrete: Comply with Section 03 30 00 "CAST-IN-PLACE CONCRETE".

### 2.7 GEOTECHNICAL FABRIC

- A. Comply with applicable articles of Section 645.2.2, Type SAS (Subgrade Aggregate Separation), of the WDOT "Standard Specifications".

## 2.8 CONCRETE CURING AGENTS

- A. Comply with Section 415.2.4 of the WDOT "Standard Specifications".

## PART 3 - EXECUTION

### 3.1 GENERAL CONSTRUCTION REQUIREMENTS

- A. Comply with the following Sections of the WDOT "Standard Specifications" except as modified herein:
  1. Subbase: Section 311.
  2. Base courses:
    - a. Aggregate: Section 305.
    - b. Asphaltic: Section 315.
    - c. Concrete: Section 320.
  3. Surface Courses:
    - a. Asphaltic Surface: Section 465.
    - b. Concrete Pavement: Section 415.
  4. Tack Coat: Section 455.
  5. Shoulders:
    - a. Aggregate: Section 305.
  6. Concrete Sidewalks: Section 602.
  7. Geotechnical fabric: Section 645.
- B. Comply with the thickness and width shown on the Drawings.
  1. Construct elevation and crown of the finished surfaces to meet the required profile and section shown on the Drawings.
- C. Compaction test for aggregate subbase, base, and surface courses:
  1. Proof-roll for compaction by driving a rubber-tired, single-unit truck with a minimum 45,000 -pound load slowly over the area to be inspected.
  2. Repair areas which show depressions or deflections greater than:
    - a. 3/4-inch deep for subbase.
    - b. 1/2-inch deep for base.
    - c. 1/4-inch deep for surface.
  3. Repeat proof-roll and/or repair until approved by the Engineer.

### 3.2 TACK COAT

- A. Asphaltic Materials:
  1. Apply tack coat on new binder course if traffic has been allowed on it and on all existing paved surfaces to be overlaid at a minimum rate of 0.05 to 0.07 gallons per square yard.
  2. Do not apply when ambient temperature is less than 36 degrees F. or when local conditions indicate that rain is imminent.

### 3.3 SURFACE COURSES

- A. Asphaltic surface:
  1. A leveling binder course will be used to correct crown or other irregularities between the existing surface and the proposed surface shape.

2. Minimum and Maximum thickness: Comply with Section 460.3.2 of the WDOT "Standard Specifications".
  3. Repair settled trenches, spalled pavement, and other defective binder before placement of asphaltic surface course.
- B. Provide asphaltic materials of a consistency to allow adequate workability around structures and joints.
- C. Acceptable tolerances for the pavement surface:
1. Longitudinal tolerance:
    - a. Sweep the surface clean and test for smoothness when finish surface is complete.
    - b. Use a 10-foot straightedge as specified in Section 415.3.11.8 or Section 450.3.2.9 of the WDOT "Standard Specifications".
    - c. Remove and replace depressions or high points which cannot be corrected by grinding or further rolling.
    - d. Grinding high points or repairing depressions shall be done at the Contractor's expense.

### 3.4 SIDEWALKS AND APPROACH SLABS

- A. Construction requirements:
1. Construct to the lines, grades, and details as shown on the Drawings.
- B. Portland Cement concrete sidewalks and approach slabs:
1. Erect temporary forms for placement of concrete as specified in Article 602.3.2.2 of the WDOT "Standard Specifications".
  2. Backfill overexcavated area with approved granular material.
  3. Construct in accordance with Section 602 of the WDOT "Standard Specifications".
    - a. Provide a minimum thickness of 6 inches for sidewalks and 8 inches for approach slabs
    - b. Install aggregate base course to the following thickness:
      - (1) 4 inches under sidewalks.
      - (2) 6 inches under approach slabs.

### 3.5 CONCRETE CURING AGENTS

- A. Comply with Section 415.2.4 of the WDOT "Standard Specifications".

END OF SECTION

## SECTION 32 31 13

### GATES

#### PART 1 - GENERAL

##### 1.1 SUMMARY

- A. Provide entrance gate as shown on the Drawings as specified herein and as needed for a complete and proper installation.
- B. Related work:
  - 1. Documents affecting work of this Section include, but are not necessarily limited to, General Conditions, Supplementary Conditions, and Division 01 - General Requirements of these Specifications.

##### 1.2 SUBMITTALS

- A. Submit shop drawings and product data in compliance with pertinent provisions of Section 01 33 01 including general dimensions, manufacturer's specifications, recommended installation procedures, and concrete footing details.

##### 1.3 QUALITY ASSURANCE

- A. Gate framework and related accessories to be a complete system as specified herein.

##### 1.4 DELIVERY, STORAGE, AND HANDLING

- A. Comply with pertinent provisions of 01 66 11.

#### PART 2 - PRODUCTS

##### 2.1 GENERAL

- A. Provide gate with general dimensions as shown and top horizontal bar 38 inches above grade.

##### 2.2 FRAMEWORK

- A. Roll formed steel sections with 2.0 ounces of hot-dipped zinc coating conforming to ASTM A-123, or Type I steel pipe, or Type II steel pipe.
  - 1. Type I: Schedule 40 steel pipe with 2.0 ounces of hot-dipped zinc coating conforming to ASTM A-120.

### GATES

2. Type II: Pipe manufactured from steel conforming to ASTM A-569, cold-formed, high frequency welded, and having a minimum yield strength of 50,000 psi. External surface triple coated with 1.0 ounce  $\pm$ 0.1 ounce of zinc per square foot, 30  $\pm$ 115 micrograms of chromate per square inch and 0.5  $\pm$ 0.2 mils of clear cross linked polyurethane. Internal surface coated, after welding, with a zinc-rich based organic coating having a 91 percent zinc powder loading capable of providing galvanic protection.
- B. Gate posts for single swing gates or one leaf of double gates with leaf width over 13 feet to 18 feet:
    1. 6-5/8-inch O.D. Type I steel pipe weighing 18.97 pounds per foot.

### 2.3 GATES

- A. Frame assembly of 2-inch O.D. Type I or Type II steel pipe with welded or steel fitted corners. Provide braces and trusses where necessary.
- B. Heavy duty hinges and positive type latching device suitable for padlocking.
- C. Semi-automatic outer catches for drive gates with 2-inch posts or 4" by 4" wooden posts embedded a minimum of 3 feet in ground with concrete encasement.
- D. Provide red and white reflective tape on all major frame work members of gate suitable for rain, snow and sun.

## PART 3 - EXECUTION

### 3.1 INSTALLATION

- A. Installation by experienced fence/gate erectors.
- B. Conform to ASTM F-567.
- C. Set all posts to a minimum depth of 36 inches in a concrete foundation.
  1. 10-inch diameter foundation for posts 4 inches and less.
  2. 12-inch diameter foundation for posts over 4 inches.

END OF SECTION

SECTION 32 92 00.13

LAWNS AND GRASSES

PART 1 - GENERAL

1.1 SUMMARY

- A. Provide topsoil, seeding and care of grass during establishment period for a complete surface restoration of lawns, parkways, and other areas disturbed as a result of the construction.
- B. Construct the work of this section in accordance with the requirements of Article 207 of the City of Madison Standard Specifications for Construction and WDOT "Standard Specifications" except as herein modified.
- C. Related work:
  - 1. Documents affecting work of this Section include, but are not necessarily limited to, General Conditions, Supplementary Conditions, and Sections in Division 01 - General Requirements of these Specifications.

PART 2 - PRODUCTS

2.1 TOPSOIL

- A. Comply with the requirements of Section 625 of the WDOT "Standard Specifications" for materials and material preparation.

2.2 AGRICULTURAL LIMESTONE

- A. Comply with applicable Articles of Section 629 of the WDOT "Standard Specifications" for materials and material preparation.

2.3 FERTILIZER

- A. Comply with the requirements of Section 629 of the WDOT "Standard Specifications" for materials and material preparation.

2.4 MULCH

- A. Vegetative mulch:
  - 1. Provide vegetative mulch for seeded areas of a high-quality, air-dried straw of wheat, rye, oats, beans, or other approved straw, free from grass, broom sedge, noxious weeds, and weed seeds detrimental to growth of grass.

- B. Hydraulic mulch:
1. Provide virgin wood cellulose fibers complying with the following properties (percent by weight):
  2. Moisture content 15
  3. Organic matter, minimum 95
  4. Water holding capacity 400
  5. pH 4.3-8.5

## 2.5 SEED

- A. Provide new crop seed furnished in standard sealed containers bearing seed tags showing purity, germination, and weed seed content, free of wild onion, Canadian thistle, crab grass, and seeds of other noxious weeds, complying with the requirements of Article 207 of the City of Madison Standard Specifications for Construction and Section 630 of the WDOT "Standard Specifications".
1. No Mow Turf: Use "No Mow Turf" seed mixture in accordance with Article 207 of the City of Madison Standard Specifications. Apply at rate of 5.0 pounds per acre.
  2. Native Grass Seed Mix: Use "Tall Grass Prairie Mix" in accordance with Article 207 of the City of Madison Standard Specifications. Apply at rate of 8.0 pounds per acre. Enhance the "Tall Grass Prairie Mix" with native flowering plant mix by adding an "Upper Midwest Seed Mix – Madison, Wisconsin Mixed Height Prairie" seed mix by Prairie Moon Nursery of Winona, MN, (866) 417-8156; info@prairiemoon.com. Apply at rate recommended by Prairie Moon Nursery.

## PART 3 - EXECUTION

### 3.1 TOPSOIL PLACEMENT

- A. Scarify the compacted subgrade to a depth of 3 inches to receive the topsoil.
- B. Spread at least 4 inches of prepared topsoil in areas of new grading raked smooth and level.
- C. Grade flush with walks, curbs, and paving.

### 3.2 PREPARATION FOR SODDING OR SEEDING

- A. Do not start preparation until all other site and utility work and finished grading within the areas to be seeded have been completed.
- B. Till topsoil to a depth of at least 3 inches and smooth out all surface irregularities resulting therefrom. Leave area free of rocks or hard soil clods which will not pass through the tines of a standard garden rake.

- C. At least 7 days before applying fertilizer, spread lime uniformly in sufficient quantity to produce in the soil a pH of 6.5. Work lime thoroughly into topsoil to a depth of 3 inches.
- D. Apply fertilizer in accordance with the WDOT "Standard Specifications".

### 3.3 SEEDING

- A. Seed all grassed areas disturbed by construction operations and not receiving sod, and as indicated on the Drawings.
- B. Sow seed between September 1 and November 1, or in spring from time ground can be worked until May 15.
- C. Apply seed during favorable climatic conditions. Do not seed in windy weather or when soil is very wet. Sow seed at the rate specified for each seed mixture.
- D. Broadcasting seeding method:
  - 1. Sow seed with mechanical seeder in two directions at right angles to each other to achieve an even distribution of seed.
  - 2. After seeding, rake seed lightly into ground and roll with a roller weighing between 100 and 200 pounds per foot of roller width.
- E. Hydraulic seeding method:
  - 1. When seed is applied with a hydraulic seeder, apply at a rate of not less than 1,000 gallons of slurry per acre containing the proper quantity of seed specified above.
  - 2. When using a hydraulic seeder, apply the fertilizer in a separate operation.

### 3.4 MULCHING SEEDED AREAS

- A. Immediately after rolling seeded areas, apply mulch at the rate of 2 tons per acre within 24 hours after seeding. Use vegetative mulch on all seeded areas unless hydraulic seeding method is used.
- B. Apply mulch in accordance with the WDOT "Standard Specifications".

### 3.5 WATERING

- A. Immediately after placing erosion control matting or mulch, water seeded areas thoroughly with a fine mist spray. Keep soil thoroughly moist until seeds have sprouted and achieved a growth of 1-inch. For sod, immediately begin watering and continually keep moist until the sod has firmly knit itself to the topsoil.



3.6 PROTECTION OF WORK

- A. Protect newly seeded and sodded areas from all traffic by erecting temporary fences and signs. Protect slopes from erosion. Properly and promptly repair all damaged work when required.

3.7 APPLICATION OF FERTILIZER

- A. Six weeks after completion of seeding or sodding apply granular fertilizer over all areas at the rate of 2 lbs. of nitrogen nutrients per 1,000 sq.ft. of area.

3.8 CLEAN-UP

- A. At the time of final inspection of work, but before final acceptance, remove from seeded and sodded areas all debris, rubbish, excess materials, tools, and equipment.

3.9 MAINTENANCE, GUARANTY PERIOD AND RETAINAGE

- A. Provide watering, mowing, and replanting and continue as necessary until a close healthy stand of specified grasses is established.
- B. Replace lawns not showing a close uniform stand of healthy specified grasses at the end of a one year guaranty period and maintain until acceptance.
- C. Madison Water Utility shall retain \$1,000 in final payment until lawns show a close uniform stand of healthy specified grasses at end of guaranty period. Contractor to maintain until final acceptance.

END OF SECTION

## SECTION 32 93 79

## TREES, PLANTS, AND GROUND COVER

## PART 1 - GENERAL

## 1.1 SUMMARY

- A. Provide trees, plants, and ground cover as indicated on the Drawings, as specified herein, and as needed for a complete and proper installation.
- B. Construct the work of this Section in accordance with WDOT "Standard Specifications" except as herein modified.
- C. Related work:
  - 1. Documents affecting work of this Section include, but are not necessarily limited to, General Conditions, Supplementary Conditions, and Division 01 - General Requirements of these Specifications.

## 1.2 SUBMITTALS

- A. Comply with pertinent provisions of Section 01 33 01.
- B. Product data: Within 60 calendar days after the Contractor has received the Owner's Notice to Proceed, submit:
  - 1. Complete materials list of items proposed to be provided under this Section.
  - 2. Complete data on source, size, and quality.
  - 3. Sufficient data to demonstrate compliance with the specified requirements.
- C. Upon completion of the work of this Section, and as a condition of its acceptance, deliver to the Engineer two copies of a Manual compiled in accordance with the provisions of Section 01 78 26 of these Specifications.
- D. Certificates:
  - 1. Require certificates required by law to accompany shipments.
  - 2. Upon completion of the installation, deliver certificates to the Engineer.

## 1.3 QUALITY ASSURANCE

- A. Use adequate numbers of skilled workers who are thoroughly trained and experienced in the necessary crafts and who are completely familiar with the specified requirements and the methods needed for proper performance of the work of this Section.
- B. Standards:
  - 1. Plants and planting material: Meet or exceed the specifications of Federal, State, and County laws requiring inspection for plant disease and insect control.

## TREES, PLANTS, AND GROUND COVER

32 93 79-1 (150826.40)

2. Quality and size: Comply with current edition of "Horticultural Standards" for number one nursery stock as adopted by American Association of Nurserymen.
3. All plants:
  - a. True to name, with one of each bundle or lot tagged with the name and size of the plants in accordance with standards of practice of American Association of Nurserymen.
  - b. In all cases, botanical names take precedence over common names.

#### 1.4 DELIVERY, STORAGE, AND HANDLING

- A. Comply with pertinent provisions of Section 01 66 11.
- B. Immediately remove from the site plants which are not true to name, and materials which do not comply with the specified requirements, and promptly replace with plants and materials meeting the specified requirements.

### PART 2 - PRODUCTS

#### 2.1 FERTILIZER

- A. Provide commercial balanced organic fertilizer for the intended use, OMRI listed, delivered to the site in bags labeled with the manufacturer's guaranteed analysis.

#### 2.2 SOIL AMENDMENT

- A. Provide Redwood sawdust fortified with organic nitrogen.
- B. Approved products:
  1. "Tillo".
  2. "Silver Spade".
  3. Or equal.

#### 2.3 MULCH

- A. Bark Mulch:
  1. Provide standard size ground bark chips 1/4-inch to 1-inch in size, mill-run chips of Douglas Fir or hardwood bark.
  2. Approved products:
    - a. "Silvabark", distributed by Weyerhaeuser Company.

#### 2.4 TREE STAKES

- A. Unless otherwise indicated on the Drawings, provide Redwood stakes, Construction grade, rough sawn, 2 inches by 2 inches by 8 feet long.

2.5 PLANT MATERIALS

- A. Provide the plant materials shown on the schedule in the Drawings.

2.6 OTHER MATERIALS

- A. Provide other materials, not specifically described but required for a complete and proper installation, as selected by the Contractor subject to the approval of the Engineer.

PART 3 - EXECUTION

3.1 SURFACE CONDITIONS

- A. Examine the areas and conditions under which work of this Section will be performed. Correct conditions detrimental to timely and proper completion of the Work. Do not proceed until unsatisfactory conditions are corrected.

3.2 SPREADING TOPSOIL

- A. Finish grading will be performed under Section 31 23 39.
- B. Upon completion of finish grading, perform fine grading required in planting areas, using soil obtained from the site.
- C. Raised planter beds:
  - 1. Backfill with a mixture consisting of two parts topsoil and one part specified soil amendment, by volume.
  - 2. Place the backfill mixture in layers not exceeding 8-inch uncompacted thickness.
  - 3. Compact each layer by thorough saturation with water to prevent future settlement.

3.3 PLANTING TREES AND SHRUBS

- A. General:
  - 1. Plant nursery stock immediately upon delivery to the site and approval by the Engineer except that, if this is not feasible, heel-in all bare root and balled materials with damp soil and protect from sun and wind.
  - 2. Regularly water nursery stock in containers, and place them in a cool area protected from sun and drying winds.
- B. Excavating:
  - 1. For shrubs in one gal containers, dig a hole 12 inches in diameter and 12 inches deep.
  - 2. For shrubs and trees in 5-gallon containers, dig a hole 20 inches in diameter and 18 inches deep.

3. For trees in 15-gallon containers, dig a hole 30 inches in diameter and 30 inches deep.
4. At holes more than 12 inches deep, probe by hand to determine if mechanical auger will hit any in-place utilities.

C. Planting:

1. Fill holes with backfill mixture consisting of three parts soil taken from the hole and one part specified soil amendment, by volume.
2. Fill to proper height to receive the plant, and thoroughly tamp the mixture before setting the plant.
3. Set plant in upright position in the center of the hole, and compact the backfill mixture around the ball or roots.
4. Thoroughly water each plant when the hole is 2/3 full.
5. After watering, tamp the soil in place until the surface of the backfill is level with the surrounding area and the crown of the plant is at the finished grade of the surrounding area.
6. Build up a temporary watering basin around the base of each tree and shrub, except no basins around trees and shrubs in turf area or in raised planter beds.

- D. Apply the specified mulch to a depth of 2-inch, evenly spread over the entire area of each soil basin.

### 3.4 STAKING

- A. Stake trees, using one stake per tree with two tree ties per stake, and driving stakes into the ground at least 2 feet.

### 3.5 INSPECTION

- A. In addition to normal progress observations, schedule and conduct the following formal inspections, giving the Engineer at least 24 hours advance notice of readiness for inspection:
1. Inspection of plants in containers prior to planting.
  2. Inspection of plant locations, to verify compliance with the Drawings.
  3. Final inspection after completion of planting:
    - a. Schedule this inspection sufficiently in advance, and in cooperation with the Engineer, so final inspection may be conducted within 24 hours after completion of planting.
  4. Final inspection at the end of the maintenance period, provided that previous deficiencies have been corrected.

### 3.6 MAINTENANCE

- A. Maintain planting, starting with the planting operations and continuing for 30 calendar days after planting is complete and approved by the Engineer.
- B. Work included:
1. Watering, weeding, cultivating, spraying, and pruning necessary to keep the plant materials in a healthy growing condition and to keep the planted areas neat and attractive throughout the maintenance period.

2. Provide equipment and means for proper application of water to those planted areas not equipped with an irrigation system.
  3. Protect planted areas against damage, including erosion and trespassing, by providing and maintaining proper safeguards.
- C. Replacements:
1. At the end of the maintenance period, verify that all plant material is in a healthy growing condition.
  2. During the maintenance period, should the appearance of any plant indicate weakness and probability of dying, immediately replace that plant with a new and healthy plant of the same type and size without additional cost to the Owner.
  3. Replacements required because of vandalism or other causes beyond control of the Contractor are not part of this section.
- D. Extension of maintenance period:
1. Continue the maintenance period at no additional cost to the Owner until previously noted deficiencies have been corrected, at which time the final inspection will be made.

END OF SECTION

Single, straight, main trunk.  
Lower branches may require  
removal for height clearance

Remove transit guard

Root flare to be level  
with the finished grade

3"-4" of woody mulch:  
Shredded or Ground  
hardwood bark mulch

Remove wire baskets; or cut top and  
fold down in pit after positioned for  
backfill planting. Cut and remove or  
fold down burlap from upper 1/2  
of ball.

Cut and remove all poly ties and burlap !!

Water thoroughly to eliminate air pockets,  
and to settle the surrounding soil

Finish Grade

Soil under ball undisturbed  
to support root ball  
and reduce settling

Break down sides of  
hole when backfilling

3 times ball diameter

Backfill: Excavated soil or amended  
as specified. Do Not Tamp !!!

2004

CITY OF MADISON  
PARKS DIVISION

STANDARD PLANTING  
TECHNIQUE FOR TREES  
IN TURF AREAS

STANDARD DETAIL DRAWING 2.01

## SECTION 33 16 19.33

## CONCRETE/STEEL COMPOSITE WATER STORAGE TANKS

## PART 1 - GENERAL

## 1.1 SUMMARY

- A. Provide concrete and steel composite water storage tank as shown on the Drawings, as specified herein, and as needed for a complete and proper installation.
  - 1. Provide a composite water storage tank consisting of a foundation, a partial second floor, reinforced concrete support structure (pedestal), and a welded steel water storage tank.
  - 2. The support structure shall extend vertically from the foundation as a circular concrete wall. A concrete slab shall be provided as structural support for the steel tank within the perimeter of the wall. A reinforced concrete ring beam shall be provided to connect the steel tank, concrete dome and concrete support wall. The elevated tank shall be in accordance with the shape, dimensions and details required by these Specifications and Drawings.
- B. Related work:
  - 1. Documents affecting work under this Section include, but are not necessarily limited to, General Conditions, Supplementary Conditions, and Division 01 - General Requirements of these Specifications.
- C. Contractors performing work described in this Section must have a minimum of ten (10) years' experience designing and constructing composite tanks and have satisfactorily designed and completed a minimum of ten (10) composite tanks of equal or greater capacity with the past five (5) years.
- D. Contractors performing work described in this Section must also have a proven performance for procurement and placement of architectural concrete including formwork design to comply with the minimum requirements of ACI 318, ACI 117 and the applicable requirements of ACI 347, including aesthetic requirements of this Section. Satisfactory performance of achieving architectural aesthetic appearance shall include a minimum of ten (10) composite tanks of equal or greater capacity with the past five (5) years.

## 1.2 SUBMITTALS

- A. Comply with pertinent provisions of Section 01 33 01.
- B. Submit:
  - 1. Summary of design for the foundation, partial second floor, pedestal, and welded steel tank including design basis, loads and results certified by a

## CONCRETE/STEEL COMPOSITE WATER STORAGE TANKS

33 16 19.33-1 (150826.40)



- licensed Professional Engineer in the State of Wisconsin. Include a finite element analysis that accurately models the intersecting elements of the interface region affected by the transfer of forces from the tank cone and tank floor to the concrete support wall.
2. Plans and details for the partial second floor certified by a licensed Professional Engineer in the State of Wisconsin.
  3. Plans and details for the reinforced concrete foundation and pedestal certified by a licensed Professional Engineer in the State of Wisconsin.
  4. Shop drawings for the welded steel tank including complete details for fabrication and assembly of steel members certified by a licensed Professional Engineer in the State of Wisconsin.
    - a. Show design data.
    - b. Include details of cuts, connections, holes, and other pertinent data.
    - c. Indicate welds by AWS symbols, and show size, type, and length of weld.
    - d. Provide setting drawings, templates, and directions for installing anchor bolts and other required anchors.
    - e. Identify details by reference to sheet and detail number of the Drawings.
  5. Certified mill test reports for the structural steel tank elements.
  6. Written report of radiographic inspection of full penetration butt-welded joints prepared by an inspection and testing agency in accordance with AWWA D107 "AWWA Standard for Composite Elevated Tanks for Water Storage".
  7. Welder qualifications in accordance with AWWA D107.
  8. Separate concrete mix design for each concrete compressive strength required, which may exceed basic concrete mix design specification in Section 03 30 00 Cast-in-Place Concrete.
  9. Concrete reinforcing shop drawings.
  10. Electrical equipment, wiring, controls and other appurtenances as noted in Drawings and these Specifications, including (but not limited to):
    - a. Lighting fixtures.
    - b. Receptacles.
    - c. Aircraft warning light.
    - d. Electric Unit Heaters.
    - e. Exhaust Fan.
    - f. Fresh Air Intake Fan and Motor Operated Damper.
    - g. Pressure Transducer.
    - h. Level Floats.
    - i. Altitude valve position indicator.
    - j. Door Entry/Intrusion Switches.
    - k. Door Swipe Entry.
    - l. Overhead Door Operator and Push Button Control.
    - m. Room Low Temperature.
    - n. Smoke and Fire Alarm.
    - o. Flood Floats.
    - p. Overflow Alarm Flow Switch.

- q. Lighting panel and power connections from new service.
- r. Security Cameras with DVR.
- s. SCADA System.
- t. Control Panel (with SCADA integration).
- 11. Cathodic Protection System.
- 12. Paint product data:
  - a. Materials list of items proposed to be provided under this Section.
  - b. Manufacturer's specifications and other data needed to prove compliance with the specified requirements.
  - c. Color charts for selection of colors by the Owner.
- 13. Scale drawing of elevated tank showing size and major appurtenances for Owner's approval.
- 14. An affidavit, prior to application of any paint coating material, from the manufacturer or supplier of the paint or coating material, that the material supplied conforms with the requirements of AWWA Specification D102.
- 15. Reports on tests for holidays in the finished interior tank surfaces and dry film thickness of all complete paint coatings in accordance with Section 8 of AWWA D102.
- 16. An affidavit, after completion of the work, from the contractor stating that all painting was done in accordance with the requirements of AWWA Specification D102.

### 1.3 QUALITY ASSURANCE

- A. Use adequate numbers of skilled workmen who are thoroughly trained and experienced in the necessary crafts and who are completely familiar with the specified requirements and the methods needed for proper performance of the work of this Section.
- B. Perform shop and field welding required in connection with the work of this Section in strict accordance with pertinent recommendations of the American Welding Society.
- C. Paint Coordination:
  - 1. After the contractor has received the Engineer's Notice to Proceed, arrange a conference with a technical representative of the paint manufacturer, the Engineer, the Contractor, and the Owner to:
    - a. Review the paint systems to be used;
    - b. Select colors;
    - c. Review painting procedures; and
    - d. Establish painting schedule.
  - 2. Notify the Engineer in writing of anticipated problems in using the specified coating system.
- D. Provide a qualified on-site supervisor employed directly by the manufacturer at all times during construction of the foundation, support structure, steel tank, and major appurtenances.

- E. Contractor to perform all elevated tank design and construction of the concrete support structure and steel tank without subcontracting any portion.
- F. Exterior Concrete Appearance:
  - 1. The exterior surface of the concrete pedestal shall meet requirements of Architectural concrete and the visual mock-up panel for uniformity in color and appearance and without pour lines, as described in these Specifications.

#### 1.4 DELIVERY, STORAGE, AND HANDLING

- A. Comply with pertinent provisions of Section 01 66 11.
- B. Delivery and storage:
  - 1. Deliver materials to the job site properly marked to identify the location for which they are intended.
  - 2. Use markings corresponding to markings shown on the approved Shop Drawings.
  - 3. Store in a manner to maintain identification and to prevent damage.
  - 4. Store paint materials in a safe, ventilated location.
  - 5. Remove oily rags, waste, etc. every day and do not allow to accumulate under any circumstances.
  - 6. Take every precaution to prevent spontaneous combustion.

#### 1.5 SPARE PARTS AND MATERIALS

- A. Upon completion of the work of this Section, deliver to the Owner one gallon of each color, type and gloss of paint used in the Work, tightly sealing each container, and clearly labeling with contents and location where used.

#### 1.6 WARRANTY

- A. Comply with SC-6.19.A of the Supplementary Conditions, except:
  - 1. Guarantee the paint work of this Section for a period of 18 months from the date of acceptance of the work and final payment by the Owner.

### PART 2 - PRODUCTS

#### 2.1 GENERAL

- A. Provide concrete/steel composite elevated water storage tank including foundation, partial second floor, concrete pedestal, steel water storage tank, and appurtenances designed in accordance with the latest editions of AWWA D107, ACI 301, ACI 303R, ACI 318, and ACI 371R.
  - 1. Provide tank having the shape shown on the Drawings with either a pitched or domed roof.
  - 2. Operating range capacity to be 1,000,000 gallons (1.0 MG).
  - 3. The operating head range to be 35 feet.

CONCRETE/STEEL COMPOSITE WATER STORAGE TANKS  
33 16 19.33-4 (150826.40)

4. The ratio of steel tank outside diameter to pedestal diameter to be no greater than 1.94.
5. Design the concrete support pedestal to maximize the usable interior space.

B. Acceptable manufacturers:

1. CBI.
2. Landmark.
3. Caldwell Tanks, Inc.
4. Or equal.

## 2.2 DESIGN LOADING

A. Design composite water storage tank including foundation, partial second floor, pedestal, and welded steel tank using load combinations and loads in accordance with latest edition of AWWA D107 and the following design parameters:

1. Risk category: IV.
2. Site classification: D.

## 2.3 TANK AND FOUNDATION DESIGN

A. Comply with pertinent building code requirements of governmental agencies having jurisdiction.

B. Provide tank foundation design including concrete ringwall and footings based on net allowable soil bearing pressure of 8,000 psf as determined by CGC, Inc. of Madison, Wisconsin with a foundation bearing depth of at least 8' below finished floor. Owner to pay for review of foundation subgrade soil conditions by independent testing agency.

C. Include an added wind load of a 2,500 pounds, distributed around perimeter at 80' above finished floor and another 2,500 pound distributed loading at 90' above finished floor for up to four cellular carriers total.

## 2.4 WELDED STEEL WATER STORAGE TANK

A. Provide steel water storage tank designed in accordance with the latest edition of AWWA D107. All exposed lap joints shall be fully seal welded on both sides.

B. Cover the concrete tank floor with a welded steel liner with a minimum plate thickness of ¼-inch for the purpose of providing a water tight boundary.

## 2.5 CONCRETE SUPPORT STRUCTURE

A. Provide concrete, formwork and concrete placement meeting the requirements of AWWA D107, in addition to the following:

1. The exposed exterior surface of the concrete support wall is designated architectural concrete.

### CONCRETE/STEEL COMPOSITE WATER STORAGE TANKS

33 16 19.33-5 (150826.40)

2. The minimum wall thickness of the concrete support structure (pedestal) to be 8 inches.
  3. Provide horizontal and vertical reinforcement on both faces.
  4. Provide all formwork and shoring required to construct the concrete structures to their intended size and shape.
  5. Use smooth, clean steel or fiberglass coated panels in good condition for formwork to provide smooth as-cast finish for exposed concrete surfaces, including interior and exterior walls.
  6. Locate ties so as to impart a continuous patterned effect to the completed pedestal. Use ties that will break off at least 1½ inches behind the exposed concrete surface.
  7. Plug holes using grout on the interior and manufactured plastic plugs on the exterior which match the color of the cured concrete as closely as possible.
  8. Utilize largest form segments practicable so as to minimize panel joints.
  9. Concrete lifts and forms:
    - a. Place all wall concrete vertically and directly inside the reinforcement cage with drop chutes to prevent form splatter and the resulting surface finish variations.
    - b. Minimum height: four feet.
    - c. Maximum height: twelve feet.
    - d. Extend form panels full height of the concrete lift using only vertical panels.
    - e. Utilize segmented placement procedures with concreting support all consisting of temporary vertical bulkheads dividing the wall pour into segments corresponding to a single batch (truck load) of concrete.
    - f. Placement of multiple batches is not permitted.
    - g. Continuously place wall segment concrete to full form height for a single load.
    - h. Place a maximum of one support wall concreting operation each day.
    - i. Seal joints using closures which impart a continuous architectural effect to the completed structure.
    - j. Use forms having a uniform pattern of vertical and horizontal rustications (approved by the Owner) to provide architectural relief to the exterior wall surface.
    - k. Locate all construction joints and panel joints in rustications.
    - l. Seal vertical panel joints using closures which combine with the form pattern to eliminate grout leakage and panel joint lines.
    - m. Finish the top of each concrete placement with a grade strip.
    - n. Proportion and combine the vertical and horizontal rustications to impart a symmetrical architectural pattern to the completed structure.
- B. Exterior Concrete Surface:
1. The exterior surface of the concrete pedestal is intended to be unpainted.

2. Provide exterior concrete surface uniform in color and appearance and without pour lines.
  3. Construct a wall mock-up panel using the proposed form work and concreting methods.
    - a. Mock-up panel must be agreed upon by the Contractor and Owner.
    - b. The mock-up panel will serve as the reference standard for surface quality, appearance, and uniformity of color.
  4. Remove forms for inspection of pours prior to proceeding with succeeding pours.
    - a. Inform Engineer of pour and inspection schedule to avoid delays.
  5. Repair or remove, if directed by the Engineer, any sections with concrete surface defects exceeding limitation specified herein or not meeting the standard represented by the mock-up panel, with acceptability as determined by Owner.
- C. Construction Tolerances for the concrete pedestal shall be as follows:
1. Circular shape: Variation from true circular cross section, and the variation from the design diameter shall be not more than  $\pm 0.4$  percent, nor more than 3 inches.
  2. Plumbness: The plumbness with respect to a reference point at the base of the structure shall be within the following:
    - a. In any 10 feet of height:  $\pm 1.0$ -inch.
    - b. In any 50 feet of height:  $\pm 2.0$  inches.
    - c. Over maximum total height:  $\pm 3$  inches.
  3. Elevation: The elevation of the whole circumference is not to vary more than  $\pm \frac{1}{2}$ -inch from an established plane.
  4. Cross Section Dimension:
    - a. Wall thickness: + 5.0 percent or – 3.0 percent.
    - b. Dome thickness: +10.0 percent or – 6.0 percent.
  5. Dome tank Floor Radius:  $\pm 1.0$  percent.
- D. The interface between the pedestal wall, tank floor plate, and the supporting structural concrete slab shall be constructed with a 1-inch minimum void. Fill this void with a flowable grout after all welds are tested and approved.

## 2.6 CONCRETE FLOOR

- A. Provide a minimum 8-inch thick, 4,000 psi concrete floor slab in the base of the support structure as designed by tank designer. The slab shall be supported on compacted granular fill and shall be reinforced with reinforcing steel for crack control. Provide 1/2-inch expansion joint between floor slab and support wall and at pipes and supports that extend through the floor. Place cap strip and sealant over the expansion joint. Reinforcing shall be suitable for HL-93 truck loadings for “composite” tank style, plus imposed loads of masonry walls. Increase floor thickness under masonry walls as required by design.
- B. Slope floor 1/8" per foot to floor drains.

- C. Provide 4-inch diameter cast iron floor drain equal to Zurn Z-551, Wade W-1300 or equal in heated valve room, with trap, as shown on Drawings.
- D. Provide Neenah R-2504 lid with Type D grate in manhole for Floor Drain/Debris Trap in center of tank, with trap and one cleanout as shown on Drawings.

## 2.7 PARTIAL SECOND FLOOR

- A. Partial Second Floor to consist of complete concrete floor with fixed ladder access, removable railing, electrical lighting around the pedestal wall, hoist and hoist I-beam above altitude valve.
- B. Provide a concrete/composite structural floor located 12 feet above the slab on grade. It shall be designed for a minimum uniform live load of 125 psf. The floor shall consist of a concrete slab supported by concrete pedestal walls and interior masonry walls.
- C. All loads transferred from the structural floor to the support wall and masonry walls and shall be considered in the design. The wall shall be strengthened as required in the vicinity of hoist I-beam connection causing point load or eccentric conditions. Loads transferred from the structural floors to the foundation shall be considered in the design of the foundation.
- D. Unless structural floor and supports are isolated from the wall, loads on the wall caused by thermal stresses in these members shall be considered. An analysis of the lateral loading condition shall be performed and the wall strengthened accordingly.
- E. Provide a rigid heavy duty steel fixed ladder access to the partial second floor. Provide curved fixed ladder railing extension a minimum of 42-inches above top of partial second floor.
- F. Provide handrails above the masonry walls to protect the open area below to the first floor. Handrails shall be 42-inch high galvanized steel handrails and permanently attached to partial second floor concrete. Handrail shall incorporate space for ladder and shall have a minimum 6' long removable section above the double doorway into the heated valve room that can be removed without unbolting permanent fasteners.
- G. Provide hoist I-beam above altitude valve with design of partial second floor. Hoist beam to have one ton (2,000-pound) capacity.
- H. Incorporate insulation and FRP panels below second floor within heated valve room and bathroom as shown on drawings.
- I. Provide perimeter lights and convenience outlets above partial second floor as shown on Drawings.

## 2.8 TANK OPENINGS AND DOORS

- A. Provide access doors and insulated overhead sectional door as specified in Division 08. Exterior personnel access door to be provided with electronic swipe card access lock system as noted in Division 08.
- B. Provide openings in tank concrete pedestal as indicated below for bidding purposes. Location, final mounting height, and final actual size will be provided to the tank manufacturer prior to the development of shop drawings.
  - 1. One: 12'-0" x 12'-0" opening for insulated overhead sectional door.
  - 2. One: 7'-0" x 3'-0" man-doors.
  - 3. One: 30" x 30" fresh air intake fan and motor operated louver opening at 6'-0" above finished floor (AFF).
  - 4. One: 30" x 30" exhaust air damper and louver opening at approximately 100' AFF.
  - 5. Eight; 6" sleeves (with plugs) for future cellular antennae at approximately 80' AFF, radially spaced around tank perimeter.
  - 6. Eight; 6" sleeves (with plugs) for future cellular antennae at approximately 90' AFF, radially spaced around tank perimeter.
  - 7. One: 4" sleeves for plumbing vents at approximately 14' AFF.
  - 8. One: 2" sleeve for sump pump discharge at approximately 2' AFF.
  - 9. One: 6" sleeve for bathroom exhaust fan at approximately 14' AFF.
  - 10. One: 3" sleeve (with plug) for future GPS Antennae at approximately 10' AFF.
  - 11. Two; 4" sleeves (with plugs) for radio antennae in access tube above elevated tank roof.
  - 12. Two; 1.5" sleeves (with plug) for level transmitter, floats and intrusion switches above in access tube above elevated tank roof.
  - 13. One; 1.5" sleeves (with plug) for level transmitter and floats in water containment hatch way extension above elevated tank roof.

## 2.9 ACCESS TUBE

- A. Provide a minimum 60-inch diameter access tube conforming to Federal and Local Safety regulations.
- B. Provide condensate gutter with a drain at the bottom of the access tube.
- C. Provide with adequate extension for noted penetrations.

## 2.10 RAIN PROOF ROOF HATCHES

- A. Provide two 30-inch square weather proof access hatches on the roof of the tank as specified in Division 08. One hatch shall allow egress from the access tube to the roof. The second hatch, located adjacent to the first, shall allow access to the interior of the tank via the ladder mounted on the exterior of the access tube.



- B. The hatch openings shall have a minimum 6-inch curb. Provide watertight aluminum covers with a 2-inch down turned edge, stainless steel hardware, hold open arm, hinge and a locking hasp.

#### 2.11 WATER CONTAINMENT AREA ACCESS MANHOLE

- A. Provide a 30-inch diameter (or equivalent elliptical) manhole into the water containment portion of the tank. The manhole shall be operable from a ladder located on the upper platform and shall be designed to withstand the pressure of the tank contents without leakage. Provide with adequate extension for noted penetrations.

#### 2.12 FREEZE PROOF AND RAIN PROOF VENT AND OVERFLOW

- A. Provide 24-mesh non-corrodible screen for vent at top of tank.
  - 1. Vent to be fail-safe design to operate if screen frosts over, with reinforced steel frames to lift off the bearing surfaces in the event of either excessive positive or negative pressure.
  - 2. Provide vent with 30-inch square access hatch provisions for second opening to interior of tank.
  - 3. Design vent with overlapping protective cap acceptable to Wisconsin DNR to prevent the entrance of rain or snow.
  - 4. Design vent to handle air flows resulting from the following:
    - a. Maximum withdrawal rate (intake).
    - b. Maximum fill rate (venting).
    - c. Maximum rate of overflow pipe (intake).
- B. Provide overflow as shown on Drawings with weir box design.
  - 1. No inverted siphon designs will be accepted.
  - 2. Incorporate vertical check valve in overflow pipe and 90-degree downturned elbow with flap valve, splash pad and rip-rap.
- C. Maximum withdrawal rate = 3,500 gallons per minute.
- D. Maximum fill rate = 2,000 gallons per minute.

#### 2.13 ANTI-TERRORIST OVERFLOW SECURITY CHECK VALVE

- A. Vertically mounted Overflow Security check valves:
  - 1. Steel enclosed, flanged or welded steel, which incorporates an all rubber "pinched" check valve with tamper proof bolts.
- B. Acceptable manufacturers:
  - 1. Vertical Mounted Overflow Security Check Valve:
    - a. Tideflex Overflow Security Valve which incorporates Tideflex Series 37 check valve in steel enclosure, No substitution.

## 2.14 FLAP VALVE

- A. Provide circular port flap valve with offset single pivoted hinge at the terminus of the tank overflow.
  - 1. Body and flap gate: Cast iron conforming to ASTM A126, Class B.
  - 2. Seats and hinge pin: Bronze.

## 2.15 TANK BALL DRAIN

- A. Provide 4-inch non-freeze tank drain to overflow pipe.
- B. Acceptable product: Shand & Jurs, Model 96181, or equal.

## 2.16 SAFETY

- A. Provide ladders, ladder guards, railings, and access hatches conforming to Federal and local laws and regulations.
  - 1. Provide a climbing safety device similar to Saf-T-Climb, as manufactured by North Safety Products, Specialty Products Division, to match City of Madison Water Utility standard.
  - 2. Include notched climbing rails, mounting brackets, locking sleeves, and two safety harnesses.
  - 3. A 2' by 3' plastic caution sign shall be provided and secured to wall at the lowest point of access to the ladder requiring safe climbing devices, reading "CAUTION – Safety Equipment Required When Climbing Ladder" in red and black lettering.
- B. Ladder Access:
  - 1. Ladders shall be provided from the first floor inside the base of the support wall to the upper walkway platform located below the tank floor. The tank floor manhole shall be provided with ladder access from the upper platform. A ladder shall extend from the upper platform, through the access tube interior to the roof. A ladder mounted on the access tube exterior shall be provided for access to the tank interior, extending from the roof manhole to the tank floor. A ladder shall be provided from first floor to the partial second floor.
  - 2. Ladders that terminate at platforms landings shall extend a minimum of 48-inch above the platform elevations. A curved railing shall be provided at the termination of the partial second floor ladder and connected to the top of the partial second floor. A safety extension shall be provided at the top of the ladder under hatch(s). The safety extension shall be a Ladder Up Safety Post as manufactured by Bilco or equal. The post shall extend 42 inches above the top of the ladder and be constructed of hot dip galvanized steel. Mounting hardware shall be galvanized.
  - 3. Ladders located in the concrete support structure and access tube interior shall be galvanized steel. Tank interior ladders shall be coated in accordance with the tank interior coating system.

4. Ladder side rails shall be a minimum 3/8-inch by 2-inch with a 16-inch clear spacing. Rungs shall be minimum 3/4-inch diameter, spaced at 12-inch centers and plug welded into holes drilled in the side rails. Tank interior ladders shall be provided with 1-inch diameter rungs and 1/2-inch x 2-inch side rails and shall be fully seal welded.
  5. Ladder shall be secured to the adjacent structure by brackets located at intervals not exceeding 10 ft. Where possible ladders shall also be attached to floors. Brackets shall be of sufficient length to provide a minimum distance of 7-inch from the center of rung to the nearest permanent object behind the ladder. Ladder brackets located on the access tube exterior shall be reinforced at the access tube shell so that potential ice damage is confined to the ladder and bracket and not the access tube shell.
- B. Provide railings or handholds around each access hatch and along roof leading to railing.
  - C. Steel Safety Railing: Provide 42-inch high, double row steel pipe handrail, on 30-foot diameter, centered on tank.
  - D. Provide two painters rings at the top of the support pedestal on the exterior of the tank and two sets of painters rigging supports inside the interior of the tank.

#### 2.17 REST PLATFORMS

- A. Rest platforms shall be provided at maximum 35 ft. intervals along the support wall ladder. Platforms shall be minimum 3 ft. by 5 ft. and complete with handrails, mid rails and toe plates in accordance with OSHA requirements. Grating shall be used for the walking surface and shall be suitably hinged at the ladder penetration. Platforms shall be arranged for straight run ladder and operable without removing fall prevention equipment. All components shall be galvanized steel.

#### 2.18 LANDING

- A. Provide a minimum 4-foot wide walkway from the pedestal wall to the center of the tank.
- B. Fabricate from galvanized steel.
- C. Provide 42-inch high, double row galvanized steel hand railing.

#### 2.19 PIPE AND PIPE FITTINGS

- A. Flanged joint ductile iron pipe and fittings:
  1. Pipe: Comply with ANSI A21.15, thickness Class 52 with pipe flanges faced and drilled to ANSI Class 125 standard template unless otherwise designated on the Drawings.
  2. Fittings: Comply with ANSI A21.10 or ANSI B16.1.
  3. Flange gaskets: 1/16-inch thick sheet rubber, full face type.

4. Flange bolts, studs, and nuts: Use cadmium plated type complying with ANSI B16.1.
  5. Provide cement lining for all ductile iron pipes and pipe fittings complying with ANSI A21.4, standard thickness.
- B. Welded steel pipe and fittings:
1. Pipe: Comply with ASTM A-53 and AP1-5L for black seamless and welded pipe.
    - a. Pipe sizes 12-inch diameter and smaller: ASA Schedule 40 weight and wall thickness.
    - b. Pipe sizes 14-inch and larger: ASA Standard weight and 0.375-inch wall thickness.
  2. Pipe flanges and fittings: Continuous weld type conforming to ANSI B16.5.
  3. Connections: Continuous butt weld type.
    - a. Welding procedures: Conform to ANSI B31.1.
    - b. Minimum yield strength of welded joints: 35,000 psi.
- C. Stainless steel pipe and fittings:
1. Pipe sizes 2½-inch and smaller:
    - a. Comply with ASTM A-312, Schedule 40, Type 316L seamless stainless steel pipe.
    - b. Fittings: Use 150 LB. 316 stainless steel screwed fittings.
    - c. In lieu of screwed fittings, Victaulic Vic-Press 304 System may be used.
      - (1) Provide pipe that is approved for use with the Vic-Press 304 system.
      - (2) O-Rings: Grade "E" EPDM (green color code).
      - (3) Ball valves: Provide Victaulic Series 569, Vic-Press 316 Type 316 stainless steel ball valves.
      - (4) Pipe supports: provide supports as specified in Part 3 of this Section and do not exceed spans recommended by Victaulic for the Vic-Press 304 system.
  2. Pipe sizes 3-inch and larger:
    - a. Piping system: Mechanical Grooved Piping System conforming to ANSI-B-31.1, B-31.3, AND B-31.9.
    - b. Pipe: comply with ASTM A-778, Schedule 10, Type 304L welded unannealed austenitic stainless steel pipe.
    - c. Fittings: smooth turn, full flow Type 304L stainless steel fittings or segmentally welded fittings with grooves designed to accept to specified couplings.
    - d. Joints:
      - (1) Rolled or cut-grooved-ends as appropriate to pipe material, wall thickness, pressures, size, and method of joining.
      - (2) Groove pipe ends in accordance with ANSI/AWWA C-606.
    - e. Couplings 3" to 12":
      - (1) Victaulic Style 489 stainless steel rigid coupling, or equal.
      - (2) Meet requirements of ASTM F-1476.

- (3) Housing: Type 316 stainless steel, conforming to ASTM A-351, A-743, and A-744 Grade CF-8M.
  - (4) Housing coating: none.
  - (5) Gaskets: Grade "E" EPDM (green color code) compound conforming to ASTM D-2000 designation 2CA615A25B24F17Z.
  - (6) Bolts and nuts: Type 316 stainless steel, oval neck track bolts and heavy hexagonal nuts with chemical and physical properties of ASTM F-593, Group 2, Condition CW.
- D. Flexible Couplings: Use slip ring sleeve type coupling between two flanged by plain end pipe segments. Sleeve type coupling to have rubber gaskets, tightening flanges and high strength bolts and nuts, Dresser Style 38, or equal. Provide a minimum of 4 tie rods of 5/8-inch diameter for each coupling with tie rod ears to secure coupling to adjacent pipe flanges.
- E. Galvanized steel pipe and fittings:
- 1. Pipe: Comply with ASTM A53, ASA Schedule 40 weight and wall thickness.
  - 2. Fittings: Use 150-pound galvanized malleable iron screwed end fittings.

## 2.20 INLET/OUTLET RISER

- A. Provide a 16-inch stainless steel inlet/outlet riser from the tank foundation and terminating near the top capacity line (maximum water level).
- B. Incorporate altitude valve, bypass piping, and appurtenances into inlet/outlet riser inside heated valve as shown on drawings and specified herein.
- C. Incorporate Tank Mixing System into inlet/outlet riser inside tank.
- D. Incorporate and install vertical expansion joints in riser pipe. Riser pipes shall be designed and constructed to accommodate differential movement caused by settlement and by thermal expansion and contraction over the range of extreme temperature differences expected for the support wall and pipe. The required flexibility shall be provided by an expansion joint located as recommended by tank manufacturer.

## 2.21 RISER PIPE INSULATION

- A. Provide 4-inch thick expanded preformed pipe insulation with corrugated aluminum jacket and stainless steel bands, and mastic seals on riser piping above condensate ceiling.
- B. Use 3M filament reinforced tank to fasten insulation to the riser and seal joints. Insulation shall be equal to Trymer Rigid Foam with aluminum jacket equal to

Childer's 0.016-inch thick with 2-inch minimum overlap and aluminum or SS screws.

## 2.22 TANK MIXING SYSTEM

### A. General:

1. The Hydrodynamic Mixing System (HMS) is defined as a supplemental system installed within a potable water storage reservoir which passively utilizes the energy provided by the inlet water supply and generates a sufficient inlet momentum to achieve a complete homogeneous blending of the water volume within the reservoir with the inlet supply flow. Determination of Complete Homogeneous Blending shall be defined by the modeling requirements and supporting hydraulic analysis as conducted by each individual manufacturer for their specific system configuration as defined within these specifications. System submittals not providing this validation shall not be considered as a viable Hydrodynamic Mixing System (HMS) and shall not be accepted as an equivalent to this system specification.
2. The specifications in this section include all components of the Hydrodynamic Mixing System (HMS) consisting of a bi-directional flow manifold equipped with variable orifice duckbill inlet nozzles and outlet flow check valves that are NSF61 certified. The HMS manufacturer shall be responsible for designing the system in accordance with the hydrodynamic criteria defined within these specifications and submit design calculations verifying compliance in accordance with the submittal requirements. The following is a description of the Hydrodynamic Mixing System.
3. All modeling and hydraulic and mixing calculations pertaining to the HMS shall originate from the duckbill valve manufacturer. Modeling and calculations provided by parties other than the duckbill valve manufacturer are not allowed.
4. The complete Hydrodynamic Mixing System shall be supplied by the variable orifice nozzle manufacturer to maintain single source responsibility for the system. The complete system shall be defined as all piping and appurtenances within the tank downstream of the tank penetration. Appurtenances include pipe, fittings, horizontal and vertical pipe supports, expansion joints, variable orifice duckbill check valves, and any other equipment specified within this section of the specifications. Approved manufacturer is Tideflex Technologies, Carnegie, PA 15106. Local Representative is RDM Municipal Supply and Service, Oak Creek, WI; 414-856-1325.
5. Manufacturer's and/or contractors submitting an alternative to the named Tideflex Technologies mixing system shall be responsible for obtaining any and all proprietary rights, license fees, royalties, technology licenses, and/or permissions required to provide such a system. The Manufacturer shall indemnify and hold harmless the Owner and Engineer against all claims, damages, losses, and expenses arising out of any infringement of patent rights or copyright incident relating to this system.

**B. Variable Orifice Duckbill Inlet Nozzles:**

1. Inlet ports/nozzles shall be duckbill-style check valves that allow fluid to enter the reservoir during fill cycles and prevent flow in the reverse direction through the nozzle during draw periods. Inlet ports/nozzles may not be fixed-diameter ports or pipes.
2. The duckbill valves shall be NSF61 Certified. NSF61 approved/Certified materials will not be accepted in lieu of valve certification.
3. Inlet ports/nozzles shall have a variable diameter vs. flow hydraulic profile that provides a non-linear jet velocity vs. flow characteristic and a linear headloss vs. flow characteristic. The hydraulic characteristics of the duckbill valves shall be defined by "Hydraulic Code".
4. The inlet ports/nozzles shall discharge an elliptically shaped jet. The nozzle must have been modeled by an independent laboratory using Laser Induced Fluorescence (LIF).
5. Manufacturer shall have at least fifteen (15) years of experience in the manufacturing of "duckbill" style elastomeric valves.
6. Manufacturer must have duckbill valves installed on manifold piping systems in at least 100 distribution system reservoirs.
7. The duckbill style nozzles shall be one-piece elastomer matrix with internal fabric reinforcing designed to produce the required discharge velocity and minimum headloss requirements as stipulated in the Submittals section. The flange portion shall be an integral portion of the nozzle with fabric reinforcing spanning across the joint between the flange and nozzle body.
8. The elastomer used in construction of the duckbill valves must have been tested by an accredited independent laboratory that confirmed there is no degradation in the elastomer when exposed to chlorine and chloramine per the ASTM D471-98 "Standard Test Method for Rubber Property – Effect of Liquids."
9. The manufacturer's name, plant location, serial number and product part number which designates nozzle size, material and construction specifications shall be bonded onto the surface of the nozzle.

**C. Outlet Check Valves:**

1. The outlet flow valves shall be perforated disc type with elastomeric membrane.
2. The valves shall be NSF61 Certified. NSF61 approved/Certified materials will not be accepted in lieu of valve certification.
3. The perforated disc shall be fabricated of stainless steel plate with welded support gussets. The disc shall be flanged and drilled to mate with ANSI B16.1, Class 125/ANSI B16.5 Class 150 flanges. The disc shall have three (3) tapped holes used for fastening the membrane and support rod to the disc with stainless steel bolts, nuts, and lock washers. The top of the disc shall be tapped and supplied with lifting eyebolt for installation.
4. The membrane shall be circular, one piece rubber construction with fabric reinforcement. The diameter of the membrane shall allow adequate clearance between the membrane O.D. and the pipe I.D. The membrane shall be vulcanized with a specified convex radius to produce a

- compression set to allow the membrane to seal against the perforated disc at low reverse differential pressure.
5. The support rod shall be stainless steel and drilled with three (3) longitudinal holes to allow fastening of rod to membrane and perforated disc.
  6. When line pressure inside the valve exceeds the backpressure outside the valve, the line pressure forces the membrane to open, allowing flow to pass through the perforations in the disc. When backpressure exceeds the line pressure, the membrane seats on the perforated disc preventing backflow.
  7. The valve allows flow out of the reservoir during draw cycles and prevents flow into the reservoir during fill cycles.
  8. The elastomer used in construction of the membrane must have been tested by an accredited independent laboratory that confirmed there is no degradation in the elastomer when exposed to chlorine and chloramine per the ASTM D471-98 "Standard Test Method for Rubber Property – Effect of Liquids".
  9. The manufacturer's name, plant location, serial number and product part number which designates membrane size, material and construction specifications shall be bonded onto the surface of the membrane.
- D. Miscellaneous: Provide the following items as required for a complete and final installation:
1. Carbon Steel Pipe and Fittings.
  2. Stainless Steel Pipe and Fittings.
  3. Fasteners:
    - a. Hex head bolts and nuts shall be stainless steel 304 conforming to ANSI/ASME B18.2.1 and ANSI/ASME B18.2.2.
    - b. Plastic insulating sleeve/washers shall be utilized to isolate dissimilar bolt and flange metals where required.
  4. Pipe Supports:
    - a. Components of the bracket assembly shall be carbon steel with a stainless steel 304 U-bolt in accordance with the associated standards.
    - b. The bracket assemblies shall consist of four components:
      - (1) A base plate (when required). For concrete tanks, the base plate will have four thru holes for expansion anchors.
      - (2) A top-works weldment that consists of structural channel and angle iron. The TMS piping shall rest on the angle iron. The angle iron has predrilled holes for the U-bolt.
      - (3) U-bolt with four hex nuts.
      - (4) An 1/8" thick EPDM strip with a length equivalent to the circumference of the pipe. The strip shall be placed between the pipe and the angle iron and U-bolt.
    - c. The channel of the top-works weldment shall be field fit and modified to the required length. The channel shall then be field welded to the base plate.



- d. For steel tanks, the base plate shall be field welded to the tank floor or shell. The location of the base plate shall avoid welded joints in the floor/shell plates.
  - e. For concrete tanks, the support shall be anchored to the concrete floor with stud type expansion anchors, the pull-out rating of the combined anchors shall be a minimum of 10 times greater than the static weight of the vertical pipe section.
  - f. Plastic insulating sleeve/washers shall be utilized to isolate dissimilar metals where required.
5. Coatings:
- a. All carbon steel and ductile iron pipe, fittings, bolted connections, pipe supports, and appurtenances shall be coated according to the interior tank paint specification as specified in this section.
  - b. **Tideflex and Waterflex Valves shall not be coated.** The valves shall either be masked or be mounted after coating of the tank and piping. Contractor to ensure masking materials are removed after coating.
6. Delivery, Storage, and Material Handling:
- a. Individual nozzles and outlet valves shall be packaged separately from the piping equipment.
  - b. All flanges shall be protected by using plastic inserts or plank wood, pipe sections are to be fully supported to prevent pipe deflection or damage to fittings or connections.
  - c. All equipment shall be shipped on pallets capable of fully supporting the pipe sections across their entire length. Pallets should be accessible for fork lift transport or strap and hoist means without causing any load to the pipe equipment.
  - d. All stainless steel components shall be stored separately away from any carbon steel components or other materials that could stain or deface the stainless steel finish from run-off of oxidized ferrous materials.
  - e. All pipe equipment should be covered and stored in areas free from contact with construction site sediment erosion to prevent accumulation of materials within the pipe and fittings.
  - f. Duckbill nozzles should be protected from contact with rigid objects during handling and storage. The contractor shall be responsible for replacing any duckbill nozzles or elastomeric components that are damaged after arrival on the site through installation and start-up of the system.
7. Submittals: Provide the following items as required for a complete and final installation:
- a. Independent CFD Modeling Validation.
  - b. Full Scale Tracer Study Validation.
  - c. Tideflex Inlet Nozzle and Waterflex Outlet Valve Testing and Validation.
  - d. Validation of long-term performance.
  - e. NSF61 Certification.
  - f. Test Report on Elastomer Exposure to Chlorine and Chloramine.

- g. System Installation Drawings.
- h. Design Calculations:
  - (1) Calculations showing the fill time required, under isothermal conditions, for the HMS system to achieve complete mix of the reservoir volume at minimum, average and peak fill rates. Complete mixing defined as 95% homogenous solution. The theory and equations used in calculating the mixing times must be from a published AWWA reference manual or paper. The reference document(s) must be submitted with the equations and calculations.
  - (2) Calculations showing the water level drawdown required to achieve complete mixing on the fill cycles at minimum, average, and peak flow rates.
  - (3) Calculations of average storage tank water age for both fill-then-draw, and simultaneous fill and draw scenarios. Theory used in calculating water age must be submitted with the calculations.
  - (4) A representative Computational Fluid Dynamics (CFD) model evaluation of the proposed HMS system configuration applied within a reservoir of similar geometry. Model output documentation shall include all design variables applied for the simulation, plot of the 3-D geometry showing the mesh definition, velocity magnitude vector and contour plots at different cross-sections throughout the water volume, simulated tracer animations showing the spatial and temporal distribution of inlet water in real time during the fill cycle.
  - (5) Hydraulic calculations showing the resulting jet velocities of each inlet nozzle at minimum, average, and peak fill rates.
  - (6) Hydraulic calculations showing the flow distribution among all inlet ports at minimum, average, and peak fill rates.
  - (7) Manifold hydraulic calculations showing the total headloss of the HMS at minimum, average, and peak fill and draw rates. Headloss shall include all minor losses and headloss of nozzles and outlet check valves.
  - (8) Hydraulic curves showing thrust vs. flow for the inlet nozzles.
  - (9) Hydraulic curves for each outlet check valves showing headloss vs. flow.
  - (10) Calculations showing the terminal rise height of the jets that discharge at an angle above horizontal. The terminal rise height shall be calculated assuming 10°F and 20°F colder inlet water and calculated at minimum, average and peak fill rates. The theory and equations used to calculate the terminal rise height shall be included.
  - (11) Hydraulic curves for each inlet nozzle of Densimetric Froude number vs. flow

- (12) If the calculations and supporting data provided do not show compliance with the hydrodynamic requirements of the system as interpreted by the Engineer or Owner then the submittal shall be rejected.

## 2.23 WALL PIPES, SLEEVES AND SEALS

- A. Wall pipes:
  1. Use cast iron mechanical joint type with rubber gaskets and flanges tapped for studs, or ANSI Class 125 flange type with flanges tapped for studs.
- B. Wall sleeves:
  1. Cast iron wall sleeves: Use mechanical joint type with flanges tapped for studs.
  2. Steel wall sleeves: Fabricate sleeve from Schedule 40 black steel pipe.
- C. Link seals:
  1. Use modular mechanical type consisting of interlocking solid rubber links designed for positive hydrostatic pressure of 20 psig.
    - a. Connect each pair of links by a carbon steel zinc phosphate plated bolt and nut each with a heavy Delrin plastic elongated washer.
  2. Acceptable product: "LINK-SEAL" as manufactured by Thunderline Corp. and supplied by Maddock Mechanical Industries, Inc., Chicago, IL or equal.
- D. Provide integral intermediate water stop wall collars for all wall pipes and sleeves.

## 2.24 BALL VALVES

- A. Provide 2-inch and smaller, 2-way, ball valves for use with 2-inch and smaller tube and piping systems.
  1. Body: Brass.
  2. Ball stem, packing washers, seat retainers, and ball retainers: Brass.
  3. Port adapters, packing nut: Brass.
  4. Handle: Nylon.
  5. Ball seat: Teflon.
  6. Adapter and retainer seals: Teflon.

## 2.25 FABRICATION

- A. Shop fabrication and assembly:
  1. Fabricate items of structural steel in accordance with AWWA D107 and as indicated on the approved Shop Drawings.
  2. Properly mark and match-mark materials for field assembly and for identification as to location for which intended.

## 2.26 PAINT MATERIALS

- A. Acceptable materials:
  - 1. The Painting Schedule in Part 3 of this Section is based, in general, on products of the Tnemec Company, Inc.
  - 2. Equal products of other manufacturers approved in advance by the Engineer, may be substituted in accordance with provisions of the Contract.
  - 3. Where products are proposed other than those specified by name and number in the Painting Schedule, provide under the product data submittal required by Article 1.2 of this Section a new painting schedule compiled in the same format used for the Painting Schedule included in this Section.
  - 4. Paints used in the interior of the tank shall be NSF 61 certified.
- B. Undercoats:
  - 1. Provide undercoat paint produced by the same manufacturer as the finish coat.
  - 2. Insofar as practicable, use undercoat and finish coat material as parts of a unified system of paint finish.
- C. Provide all paints and materials supplied by one manufacturer in colors selected by the Owner.

## 2.27 PAINT APPLICATION EQUIPMENT

- A. For application of the approved paint, use only such equipment as is recommended for application of the particular paint by the manufacturer of the particular paint, and as approved by the Engineer.
- B. Prior to use of application equipment, verify that the proposed equipment is actually compatible with the material to be applied, and that integrity of the finish will not be jeopardized by use of the proposed equipment.

## 2.28 ELECTRICAL EQUIPMENT

- A. General:
  - 1. Provide complete electrical system as shown on the Drawings, as specified herein, and as needed for a complete and proper installation.
  - 2. Comply with requirements of the National Electric Code (NEC), local government regulations, and local utility requirements.
  - 3. Comply with pertinent provisions of Division 26.
  - 4. Provide two 3-inch PVC sleeves through the wall of the foundation in addition to those shown on the Drawings for future conduits.
- B. Conduit, fittings, and boxes:
  - 1. Comply with Section 26 05 33.

- C. Wiring:
1. Comply with Section 26 05 19.
- D. Wiring devices:
1. Comply with Section 26 27 26.
- E. Ladder and Access Tube Lighting fixtures:
1. Provide Crouse-Hinds "Vaporgard" vapor-proof LED type fixture EVLED C201, or equal, with guard, to operate on 120 volts.
  2. Provide with appropriated mounting brackets to fit location.
  3. Fixtures to be wired so lighting fixtures can be replaced in future without affecting other wiring.
- F. Aircraft warning light:
1. Provide Hubbell AWDP3120, or equal.
  2. LED, dual unit to operate on 120 volts.
- G. Lighting panel:
1. Comply with Section 26 24 16.
- H. Ground rod:
1. Provide 5/8-inch diameter copper clad steel ground rod, 10 feet long.
- I. Electrical service:
1. Provide necessary wiring and equipment for a complete electrical service as shown on the Drawings.
  2. Service to be 480 volt, three phase, 60 Hertz rated at 30 amperes.
  3. Service to come from Alliant Energy per Section 26 60 20.
- J. Control Wiring:
1. Provide necessary wiring and equipment to convey signals for control back to Madison Water Utility SCADA system as indicated herein.
  2. Control/signals to be delivered from the following equipment items:
    - a. Pressure Transducer levels 4/20ma.
    - b. Level Floats (open/closed).
    - c. Altitude position indication (open/closed).
    - d. Door Switches (open/closed).
    - e. Room Low Temperature alarm/switch.
    - f. Smoke/Fire Alarm switch.
    - g. Security Cameras.
    - h. Door Entry Swipe provisions.
    - i. Flood Float.
  3. Provide conduit, wiring, penetrations, and other provisions required to provide control equipment within elevated tank to be relayed to control wiring at Control Panel and integrate into the SCADA system.

## 2.29 CATHODIC PROTECTION SYSTEM

- A. Provide automatically controlled, impressed-current cathodic protection system designed to protect the interior surfaces of the tank, as manufactured by Harco Waterworks C.P.
- B. Comply with ANSI/AWWA D104, latest edition, "AWWA Standard for Automatically Controlled, Impressed-Current Cathodic Protection for the Interior of Steel Water Tanks".
- C. Comply with ANSI/NSF 61 for all system components in contact with water.
- D. Provide Type A – IR drop free system and submerged spider-type horizontal anode suspension for icing tank with a minimum ten year design life.
- E. Automatic rectifier unit:
  - 1. Provide unit to automatically maintain direct current at the optimum level necessary to prevent tank corrosion utilizing a reference electrode for control system feedback.
  - 2. Include a transformer, control circuitry, meters, operation selector, selenium or silicon rectifying elements, circuit breaker(s) and lighting, surge and overload protection.
  - 3. Provide unit operating on 120 volt, 60 Hertz, single phase alternating current.
  - 4. Provide NEMA 3R steel cabinet for mounting unit.
  - 5. Provide number and type of electrical wires required for electrical service and the cathodic protection system.
  - 6. Provide monitoring lights on the exterior of cabinet to display system performance.
- F. Tank anode assembly:
  - 1. Provide platinized niobium or titanium with a precious metal oxide coating.
  - 2. Provide continuous anode wire with a maximum of two (2) anode to power cable connections.
  - 3. Provide anode suspension system consisting of polyester cord secured to steel anchors welded to the side wall of the tank bowl or to the exterior of the dry access column.
- G. Pressure entrance fitting:
  - 1. Provide a pressure entrance fitting at the base of the tank to accommodate anode and reference electrodes lead wires.
  - 2. Manufacture fitting to prevent leakage through fitting and water migration through the wire insulation.

### 2.30 SUPPORT STRUCTURE VENTILATION

- A. Ventilation for the support column shall include one 30-inch by 30-inch fresh air inlet louvered wall opening with fan and motor operated damper, equal to the following:
  - 1. Greenheck SS1-20-428-C6 with 120 volt, 1/6 Hp motor.
  - 2. Greenheck motor damper, damper guard, OSHA guard, and supply grille in wall mounting housing.
  - 3. Greenheck/ESD – 403 with color selected by Owner.
- B. Provide 30" by 30" exhaust air louver with gravity damper at top of concrete pedestal approximately 90 feet AFF, equal to the following:
  - 1. Greenheck gravity operated damper ES-10 in wall mounting housing.
  - 2. Greenheck/ESD – 403 with color selected by Owner.
- C. Support structure louvered opening shall be accessible from the upper platform and may also be designed to provide access to the exterior rigging rails located at the tank/support wall intersection.
- D. Fan and ventilation louver shall be accessible from the first floor.
- E. Control operation of fan and motor operated damper with on/off manual control switch located by fan and fresh air inlet damper on first floor.

### 2.31 LIGHTNING PROTECTION

- A. Provide a lightning protection system for the elevated tank structure and any roof mounted equipment that may be damaged by lightning.
- B. Minimum requirements include two 28 strand by 14 gauge copper conductors bonded to the steel tank 180 degrees apart. The conductors shall be fastened to the interior support wall at 3-foot minimum spacing, and shall terminate with buried 5/8-inch diameter by 8-foot long copper clad ground rods.
- C. Lightning protection for obstruction lights shall consist of an air terminal mounted on the support and formed to fit around the fixture. The ½-inch diameter copper air terminal shall extend a minimum of 10 inches above the light fixture and shall connect to a copper conductor that terminates in a bonding plate secured to the tank roof.

### 2.32 SCADA AND ELECTRONIC ACCESS CONTROL

- A. Tank Contractor to provide SCADA and Electronic Access Control Subcontractors.
- B. SCADA Contractor will be responsible for the installation of all noted SCADA, Security and Electronic Access devices, including miscellaneous piping and fittings, electrical power connections, plus relay and termination of I/O signals

from devices to SCADA panel in valve room. Tank Contractor to coordinate with Electronic Access Control Consultant provided items and provide power to equipment requiring power above 120 volts. SCADA Consultant shall be responsible to install (or have an electrical subcontractor) to provide their equipment and provide necessary control wire/cabling for proper operation. Comply with provisions of Sections 40 90 10 and 40 91 10.

- C. SCADA Provisions to include but not be limited to the following:
1. Furnish tank level float and pressure transducers.
  2. Furnish Door Switches.
  3. Furnish low temperature, flood floats, intrusion switches and smoke/fire alarms.
  4. Furnish SCADA control panel with PLC, modem, and other misc. panel components.
  5. Security Cameras and DVR.
  6. Access Control Door Swipe.
  7. Radio Communications and Antennae (with provisions for future fiber optic).
  8. Door locks/strikes for reader wire.
  9. Wireless antenna to be mounted on tank exterior.
  10. Separate power supply for the door lock.
  11. Provide 4½-inch pressure gauge (1/2% accuracy) along with miscellaneous ball valves and piping as shown for Pressure Transmitter piping detail.
  12. Calibrate and configure all instruments.
  13. Provide local tower PLC programming and data communications to SCADA.
  14. Provide SCADA master PLC programming and software development to incorporate the tower into the existing SCADA system.
  15. Provide start-up and testing services.
  16. Coordinate activities with Contractor.
  17. Provide final documentation on CD including program backup copies, wiring schematics, and equipment manuals.
- D. Tank Contractor to coordinate with SCADA Contractor to meet SCADA requirements.

### 2.33 FUTURE CELLULAR ANTENNAE PROVISIONS

- A. Provide sixteen (16) 8-inch diameter penetrations, with capped couplings, through the tank wall, located approximately 2 feet above the foundation floor as shown on Drawings.
- B. Provide suitable clips attached to the inside of the tank pedestal and access tube to secure future antenna cables.



## 2.34 OTHER MATERIALS

- A. Provide other materials, not specifically described but required for a complete and proper installation, as selected by the Contractor subject to the approval of the Engineer.
- B. Provide supports and bracing for all components.

## PART 3 - EXECUTION

### 3.1 SURFACE CONDITIONS

- A. Examine the areas and conditions under which work of this Section will be performed. Correct conditions detrimental to timely and proper completion of the Work. Do not proceed until unsatisfactory conditions are corrected.

### 3.2 GENERAL CONSTRUCTION REQUIREMENTS

- A. Comply with requirements of federal, state local and other governmental agencies having jurisdiction.
- B. Maintain a health and safety program including temporary facilities and controls complying with the legal requirements imposed by and under the authority of the Occupational Health and Safety Administration (OSHA) including current and interim standards.

### 3.3 ERECTION

- A. Comply with AWWA D107, ACI 303R and ACI 371R except as may be modified herein.
- B. Surveys:
  - 1. Establish permanent benchmarks necessary for accurate erection of tank.
  - 2. Check elevations of concrete surfaces, and locations of anchor bolts and similar items, before erection proceeds.
- C. Field assembly:
  - 1. Set structural frames and plates accurately to the lines and elevations indicated.
  - 2. Align and adjust members before fastening permanently.
  - 3. Adjust as required to compensate for discrepancies in elevation and alignment.
  - 4. Seal weld all interior lap joints.
  - 5. Install pipe and pipe insulation in accordance with manufacturers' recommendations.

### 3.4 FIELD QUALITY CONTROL

- A. Provide the services of an independent qualified testing and inspection agency, approved by the Engineer to inspect and test materials, fabrication and field welding work in accordance with AWWA D107, as amended herein.
- B. Replace defective welding.
- C. Perform tank leakage testing after completion of erection, painting, and disinfection.
  - 1. Provide all equipment and devices necessary to fill tank from Owner's water system.
    - a. The Owner will provide water for initial leakage testing at no charge to the Contractor.
  - 2. Fill tank with water to the overflow level.
  - 3. Repair, repaint, and disinfect leaks and other defects discovered during testing.
  - 4. Retest by refilling the tank.
    - a. Pay for water used to refill the tank at the Owner's regular water service rate.
- D. Concrete testing: Test fresh concrete in accordance with AWWA D107. Additional considerations for Concrete Support Structure Construction are noted in Item 3.5 of this Section.
- E. Electrical testing:
  - 1. Provide operational testing for electrical devices.
  - 2. Test receptacles for correct polarity, proper ground connection, and wiring faults.
    - a. Measure and record resistance levels at ground rod.
  - 3. Measure in normally dry condition not less than 48 hours after rainfall.
    - a. Isolate ground under test from other grounds.

### 3.5 CONCRETE SUPPORT STRUCTURE

- A. Architectural Concrete Construction:
  - 1. The exposed exterior surface of the concrete support wall is designated architectural concrete. The concrete and formwork requirements of this section shall be strictly enforced to ensure concrete of the highest practicable architectural standard. Formwork design, installation and removal shall comply with the minimum requirements of ACI 318, ACI 117 and the applicable requirements of ACI 347, except as modified by this Section.
  - 2. Attention shall be given to ensure the same concrete design mix is used throughout the support wall. The proportion, type and source of cement and aggregates shall not be changed. Uniform moisture content and placing consistency shall be maintained.

3. Placement is crucial to achieving architectural concrete. All wall concrete shall be placed vertically and directly inside the reinforcement cage with drop chutes to prevent form splatter and the resulting surface finish variations. Placement methods that introduce concrete horizontally through wall reinforcement are strictly prohibited.
4. Support wall reinforcement shall be installed with plastic supports. Maximum spacing of supports for welded wire fabric shall be 5 ft. centers, horizontal and vertically. Forming systems shall be designed with the provision of ties and bracing such that concrete components conform to the correct dimensions, shape, alignment and elevation. Embedded items shall be properly positioned and secured. Form surfaces shall be thoroughly cleaned of concrete residue and coated with a release agent prior to placing reinforcement. Do not allow excessive release agent to accumulate on the form surface. Steel forms shall be coated with a non-staining, rust preventative form oil or otherwise protected. Steel formwork with rust stains and damaged surfaces shall not be used.
5. Support wall concreting shall incorporate segmented placement procedures. Temporary vertical bulkheads shall divide the wall pour into segments corresponding to a single truckload of concrete. The bulkheads shall be located at rustications, braced rigid and tight to maintain vertical alignment under concrete load. Wall segment concrete shall be placed vertically and continuously to full form height from a single truck load of concrete. Vertical pour rate shall be a minimum of 15 feet per hour. Placement from multiple loads is not permitted. Temporary bulkheads shall not be removed until adjacent concrete is placed.
6. The forming system for the pedestal wall shall be fully engineered and detailed with procedures to meet the increased demands of architectural concrete. The support wall shall be constructed with a jump form process using form segments prefabricated to match the wall curvature. Concrete pour height shall be a minimum of 4 ft. and a maximum of 10 ft. Form panels shall be designed for lateral pressures associated with full height plastic concrete head and eccentric loads resulting from the segmented wall pour procedure.
7. Form panels shall extend the full height of the concrete pour using only vertical panel joints. Form system shall be designed to lap and be secured to the previous wall pour. The space between the form and the previous pour shall be sealed to prevent grout leakage. Wall forms shall incorporate a positive means of adjustment to maintain dimensional tolerances specified. Wall forms shall be adjusted for vertical plumb and circularity and locked into position with through wall form ties prior to concrete placement. Working platforms that allow safe access for inspection and concrete placement shall be provided. Form surfaces shall be steel, plastic or fiberglass coated material.
8. The form system shall incorporate a uniform pattern of vertical and horizontal rustications to provide architectural relief to the exterior wall surface. Rustication strips shall be sealed to the form face to eliminate the grout leakage that results in broken corners, color variations and rock pockets. Broken edges and chamfers will not be accepted. All construction joints and panel joints shall be located in rustications.

Vertical panel joints shall be sealed using closures which combine with the form pattern to eliminate grout leakage and panel joint lines. All joints shall be grout tight. The vertical and horizontal rustications shall be proportioned and combined to impart a symmetrical architectural pattern to the completed structure. Form ties shall be located in a uniform pattern. No architectural form treatment is required on the interior surface.

9. Wall forms shall not be disturbed or removed until the concrete has attained sufficient strength to prevent forming operations or environmental loads from causing surface damage or excessive stress. Support wall concreting operations shall occur a maximum of once per day. Forms are to be removed and the concrete finish inspected prior to the subsequent placement of the next wall pour. Multiple form movements and concrete placements within a day are not permitted. Form removal shall be based on early age concrete strength testing. The minimum concrete strength shall be established by the Contractor, based on an analysis of stress at critical stages throughout the forming and concrete operations. Early age concrete testing shall be in accordance with ACI 228.1R-95. Pull Out testing in accordance with ASTM C 900-99, Maturity Method testing in accordance with ASTM C 1074-93, or field cured cylinders compressive strength tested in accordance with ASTM C 172 are the acceptable methods to determine early concrete strength.
10. The structural floor system shall be designed to support all temporary construction loads. Adequate shoring and bracing shall be provided to transfer loads without appreciable movements. Shoring and forms for the structural dome slab shall remain in place until the concrete has gained sufficient strength to carry the floor weight without damaging deflections. A system of precast segments, concreted and structurally tied together can be used in lieu of cast in place.
11. In periods of cold weather as defined by ACI 306, concrete surfaces shall be protected in accordance with recommendations until the component attains 35% of the specified compressive strength. At this time, protection may be removed subject to the allowable temperature differential. A reasonable temperature differential shall be defined, based on component thickness and restraint conditions.

B. Placement:

1. Concrete shall be placed in "one" continuous pour for partial segmented or full wall height being poured. Full wall height pours will be limited to a maximum of 4 feet high. For pours requiring more than one concrete truck, a hopper will be required to allow the blending of concrete from the multiple trucks and pumped into place with a concrete pumper. Backup provisions for a second concrete pumper truck shall be provided to ensure a continuous pour.

C. Finish:

1. Provide a smooth form finish without rub for the interior and exterior support wall. Tie holes shall be plugged using grout on the interior and manufactured plugs on the exterior which match the color of the cured

concrete as closely as possible. Provide a light sandblast to the exposed exterior concrete support wall surface.

### 3.6 PAINTING

- A. Paint all interior and exterior exposed metal surfaces in accordance with the requirements of AWWA Standard D102, latest edition, Standard for Painting Steel Water Storage Tanks, as amended herein.
- B. Schedule work to provide the Engineer with 72-hour notice for inspection of surface preparation and painting prime, intermediate, and finish coats.
- C. Site conditions:
  - 1. Apply paint under weather conditions specified by the paint manufacturer as being suitable for use during application and drying periods.
  - 2. Do not apply paints when the temperature of surfaces to be painted and the surrounding air temperatures are below 50 degrees F, unless otherwise permitted by the manufacturer's printed instructions as approved by the Engineer.
  - 3. Do not apply paint in snow, rain, fog, or mist; or when the relative humidity exceeds 85 percent; or to damp or wet surfaces, unless otherwise permitted by the manufacturer's printed instructions as approved by the Engineer.
- D. Surface preparation:
  - 1. Perform preparation and cleaning procedures in strict accordance with the painting schedule.
  - 2. Clean all metal surfaces of mill scale and rust after fabrication and immediately prior to application of a full coat of primer paint.
    - a. Shop cleaning of surfaces: Blast cleaning or pickling.
    - b. Field cleaning of surfaces: Blast cleaning.
  - 3. Remove removable items such as hardware, accessories, nameplates and fixtures which are in place and are not scheduled to receive paint finish; or provide surface applied protection prior to surface preparation and painting operations.
  - 4. Following completion of painting in each space or area, reinstall the removed items by using workmen who are skilled in the necessary trades.
  - 5. Schedule the cleaning and painting so that dust and other contaminants from the cleaning process will not fall onto wet newly painted surfaces and other surfaces.
  - 6. Thoroughly clean surfaces until free from dust, dirt, black oxide, scale, rust, paint, oil, and grease in accordance with the Society of Protective Coatings (SSPC) Specifications required in Paint Schedule.
  - 7. Allow to dry thoroughly before application of paint.
- E. Materials preparation:
  - 1. Mix and prepare paint materials in strict accordance with the manufacturer's recommendations as approved by the Engineer.
  - 2. When materials are not in use, store in tightly covered containers.
  - 3. Maintain containers used in storage, mixing, and application of paint in a clean condition, free from foreign materials and residue.

4. Stir materials before application, producing a mixture of uniform density.
5. Do not stir into the material any film which may form on the surface, but remove the film and, if necessary, strain the material before using.

F. Application:

1. Apply paint coating in accordance with SSPC Paint Application Specification No. PA1 and manufacturer's recommendations, with colors selected by the Owner.
2. Paint name of Owner and logo on two sides of the tank with size and style of italic script type letters selected by the Owner (see attached example).
3. Tint each prime, intermediate, and finish coat differently for contrast to assure complete coverage of surfaces.
4. Notify the Engineer or the Owner of the completion of each coat.
  - a. Do not apply additional coats until the completed coat has been inspected and approved.
  - b. Only the inspected and approved coats of paint will be considered in determining the number of coats applied.
5. Provide an approved gauge for determining the mil thickness of the paint on a surface.
6. Allow sufficient drying time between coats, modifying the period as recommended by the material manufacturer to suit weather conditions.

Dry Film – mils

G. Paint schedule:

1. Interior wet areas and metal surfaces of water storage tank and other metal surfaces which will be in contact with water:
  - a. Comply with AWWA D102, Inside Coating System No. 5, as amended herein.
  - b. Shop surface preparation: Remove all oil and grease from the surface prior to blast cleaning. Abrasive blast clean all surfaces in accordance with SSPC-SP10 Near White Metal Blast Cleaning. A minimum surface profile of 1.5 mils is required.
  - c. Shop prime coat: Series 94 H<sub>2</sub>O Hydro-Zinc. 2.5 - 3.5
  - d. Field surface preparation: Remove all oil, grease, dust, dirt and foreign matter from the entire surface. Grind weld slag, weld spatter, rough edges and sharp edges of weld seams smooth. Abrasive blast clean all rusted, abraded and unpainted areas in accordance with SSPC-SP10 Near White Metal Blast Cleaning. A surface profile of 1.5 mils is required.
  - e. Field prime coat: Series 91 H<sub>2</sub>O Hydro-Zinc to all bare metal surfaces. 2.5 - 3.5

Dry Film – mils

- |    |  |                  |
|----|--|------------------|
| f. | Stripe coat: Hand apply, by brush only, one coat of Series N140-39BL Delft Blue Pota-Pox Plus to all weld seams, sharp edges, angles, etc.   |                  |
| g. | Field intermediate coat: Series 20HS, Chicago Beige Pota-Pox.  | 6.0 - 8.0        |
| h. | Field finish coat: Series 20HS, Tank White Pota-Pox.   | <u>6.0 - 8.0</u> |
|    |  | 14.5 – 19.5      |
|    |  |                  |
| 2. | Interior dry area and non-immersed exposed metal surfaces of the supporting structure and appurtenances:   |                  |
| a. | Comply with AWWA D102, Inside Coating System no. 5, as amended herein.   |                  |
| b. | Shop surface preparation: Remove all oil and grease from the surface prior to blast cleaning. Abrasive blast clean all surfaces in accordance with SSPC-SP6 Commercial Blast Cleaning. A minimum surface profile of 1.0 mil is required.   |                  |
| c. | Shop prime coat: Series 94 H <sub>2</sub> O Hydro-Zinc.  | 2.5 - 3.5        |
| d. | Field surface preparation: Remove all oil, grease, dust, dirt and foreign matter from the entire surface. Grind weld slag, weld spatter, rough edges and sharp edges of weld seams smooth. Abrasive blast clean all rusted, abraded and unpainted areas in accordance with SSPC-SP6 Commercial Blast Cleaning. A surface profile of 1.0 mil is required. |                  |
| e. | Field prime coat: Series 91 H <sub>2</sub> O Hydro-Zinc to all bare metal surfaces.  | 2.5 - 3.5        |
| f. | Field intermediate coat: Series 20HS, Chicago Beige Pota-Pox.  | 6.0 - 8.0        |
| g. | Field finish coat: Series 20HS, Tank White Pota-Pox.   | <u>6.0 - 8.0</u> |
|    |  | 14.5 – 19.5      |
|    |  |                  |
| 3. | Exterior exposed metal surfaces of elevated tank, supporting structure, and appurtenances:   |                  |
| a. | Comply with AWWA D102, Outside Coating System No. 4, as amended herein.  |                  |
| b. | Shop surface preparation: Remove all oil and grease from the surface prior to blast cleaning. Abrasive blast clean all surfaces in accordance with SSPC-SP6 Commercial   |                  |

Dry Film – mils

- |    |  |                               |
|----|--|-------------------------------|
|    | Blast Cleaning. A minimum surface profile of 1.0 mil is required.  |                               |
| c. | Shop prime coat: Series 94 H <sub>2</sub> O Hydro-Zinc.  | 2.5 - 3.5                     |
| d. | Field surface preparation: Remove all oil, grease, dust, dirt and foreign matter from the entire surface. Grind weld slag, weld spatter, rough edges and sharp edges of weld seams smooth. Abrasive blast clean all rusted, abraded and unpainted areas in accordance with SSPC-SP6 Commercial Blast Cleaning. A surface profile of 1.0 mil is required. |                               |
| e. | Field prime coat: Series 91 H <sub>2</sub> O Hydro-Zinc to all bare metal surfaces.  | 2.5 - 3.5                     |
| f. | Additional spot prime coat: Series 135-DC74 Chembuild to all Engineer determined inaccessible and hard to reach areas, such as the inside of anchor bolt chairs, vent, manways, tie rods, turnbuckles, painters rings, and accessories.  |                               |
| g. | Field intermediate coat: Series 73-color Endura-Shield.  | 2.0 - 3.0                     |
| h. | Field finish coat: Series 700-color HydroFlon.   | <u>2.0 - 3.0</u><br>6.5 - 9.5 |
- H. Verify the dry film thickness of all completed paint coatings and test for holidays in the finished interior tank surfaces in accordance with Section 8 of AWWA D102. All tests shall be witnessed by the Engineer or the Owner's representative.
1. A test report shall be submitted to the Engineer.

### 3.7 DISINFECTION

- A. Disinfect the tank in accordance with AWWA C652.
1. Provide all equipment and devices necessary to fill tank from Owner's water system.
    - a. The Owner will provide at no charge to the Contractor water for the initial filling.
  2. Provide sampling tap to facilitate collection of water samples.
  3. Procure necessary water sample containers.
  4. Collect water samples for bacteriological analysis on two successive days at least 24 hours apart.
  5. Send water samples to a laboratory approved by the State agency responsible for the safety of public water systems.
  6. Repeat the disinfection procedure until satisfactory water samples are obtained, paying the entire cost of draining and refilling the tank.



### 3.8 ELECTRICAL WORK

- A. Coordinate installation of electrical service to site with local utility company and Owner/Engineer.
- B. Install conduit, boxes, wiring, fixtures, wiring devices, panels, and electrical equipment in accordance with NEC, manufacturer's written instructions, applicable standards, and recognized industry practices to ensure products serve intended function.
- C. Run conduits parallel to or at right angles with lines of structure.
- D. Clean electrical boxes of dirt and debris before installing wiring devices or light fixtures.
- E. Install top of underground conduit 30 inches below final grade or at depth shown on the Drawings.
- F. Coordinate telemetry panel installation with City's system integrator.

### 3.9 TANK MIXING SYSTEM

- A. Installation of the manifold system shall be in accordance with the installation plans and guidelines provided by the HMS manufacturer and as specified in the installation section of the IOM manual. Refer to section on Submittals for quantities and delivery schedules of the documents.
- B. Installation Inspection and Start-Up Testing Procedures:
  - 1. The TMS manufacturer's authorized representative shall provide one (1) day inspection to verify that the system has been installed in accordance with the design specifications and installation drawings.
  - 2. Start-Up Flow Testing:
    - a. Following installation of the complete manifold piping system, the contractor shall open the upstream isolation valve to allow flow into the tank through the manifold system. The isolation valve must be opened slowly to prevent surge or over-pressurization of the manifold system. The isolation valve must be fully opened to inspect the flow characteristics of the manifold system.
    - b. The contractor and factory representative shall visually inspect the entire piping system for leakage.
    - c. The contractor and factory representative shall visually inspect all of the inlet nozzles to ensure flow is being discharged into the tank through all nozzles.

### 3.10 CATHODIC PROTECTION EQUIPMENT SERVICE AGREEMENT

- A. Furnish a service agreement for the type of system installed. Include the annual service rate and a complete description of the scope of work proposed. Perform

inspection and annual testing in accordance with ANSI/AWWA D104, latest edition and include as a minimum:

1. One annual job site visit.
2. Conduct tank-to-water potential measurements conducted at minimum five representative locations within the tank.
3. Conduct measurements with a portable high impedance voltmeter and calibrated copper-copper sulfate reference cell.
4. Make appropriate adjustment for optimum corrosion control.
5. Provide sufficient information to evaluate the performance of the system relating to criteria for protection.
6. In the event additional work is required, submit a report with recommendations for optimizing corrosion control.

### 3.11 VALVES

- A. Install valves in accordance with manufacturer's recommendations.
- B. Install altitude valve with reservoir sensing line connection to water service line.
- C. Install vertical anti-terrorist check valve in overflow pipe to ensure that valve is normally closed during non-overflow (dry conditions) and will open to allow release of water during overflow events. Provide inspection port in piping above vertical check valve and flow switch in piping below vertical check valve as shown on drawings.

END OF SECTION

## SECTION 33 32 26

## SUBMERSIBLE SUMP PUMP PUMPING SYSTEM

## PART 1 - GENERAL

## 1.1 SUMMARY

- A. Provide submersible sewage grinder pumping system as shown on the Drawings, as specified herein, and as needed for a complete and proper installation.
- B. Related work:
  - 1. Documents affecting work under this Section include, but are not necessarily limited to, General Conditions, Supplementary Conditions, and Division 01 - General Requirements of these Specifications.
- C. References:
  - 1. Reserved.

## 1.2 SUBMITTALS

- A. Shop Drawing Submittals – None Required.
- B. Operation and Maintenance Manuals – Submit operation and maintenance manuals in compliance with pertinent provisions of Section 01 78 26.
- C. Certificates and Guarantees – None Required.
- D. Lubricants – None Required.
- E. Spare Parts – None Required.

## 1.3 QUALITY ASSURANCE – Reserved.

## 1.4 DELIVERY, STORAGE, AND HANDLING

- A. Comply with pertinent provisions of Section 01 66 11.

## 1.5 SITE CONDITIONS – Reserved.

## 1.6 MAINTENANCE – Reserved.

## PART 2 - PRODUCTS

## 2.1 GENERAL

- A. Provide simplex sump pumping system complete, ready for operation including:
  - 1. Submersible sump pump and motor.
  - 2. Sump and cover.
  - 3. Electrical controls.
  - 4. Piping and fittings.

## SUBMERSIBLE SUMP PUMP PUMPING SYSTEM

33 32 26-1 (150826.40)

- B. Acceptable manufacturers: Metropolitan Pump Company, or equal.

## 2.2 SUMP PUMP AND MOTOR

- A. Provide submersible sump pump having a discharge capacity of 20 gpm when operating against a total head of 17 feet at a maximum speed of 3500 rpm.
  - 1. Acceptable manufacturers: Hydromatic Model HP33 or equal.
- B. Pump construction: cast iron pump casing, Naryl impeller with bronze insert, stainless steel shaft, and 440C stainless steel self-adjusting dual cutters hardened to Rockwell 60C.
- C. Motor construction: 1/3 horsepower, oil-filled submersible motor with cast iron housing, tandem mechanical seals, and overheat sensor, for operating on 120 volt, single phase, 60 Hertz A. C. power source.

## 2.3 SUMP AND COVER

- A. Provide a sump with cover to enable the pump to be removed.
  - 1. Sump: Minimum 18-inch nominal diameter sump fabricated from minimum 1/2-inch fiberglass complete with a 3/8-inch steel cover.

## 2.4 ELECTRICAL CONTROLS

- A. Provide electronic level sensor (ION switch) for pump on/off operation with a NEMA 4X junction box, complete with necessary accessories and fittings.
- B. Provide a control panel with a circuit breaker, a magnetic starter with overload protection, pump run light, an H-O-A switch complete with control wirings in a NEMA 4X enclosure.

## 2.5 PIPE AND FITTINGS

- A. Pump discharge pipe and fittings: Use 1½-inch Schedule 80 PVC pressure pipe and fittings with a minimum pressure rating of 125 psi at 73 degrees F, conforming to ASTM D1785.
  - 1. Joints: Use solvent-weld socket type, or threaded type.
  - 2. Provide union for disassembly of pipe and manual pump removal.

## PART 3 - EXECUTION

### 3.1 INSTALLATION OF SUMP AND PUMPING EQUIPMENT

- A. Install sump and controls in accordance with the manufacturer's recommendations.
  - 1. Install control panel at location as directed by the Engineer or the Owner.
  - 2. Install conduits and wirings between the control panel and the sump complete as required by the equipment manufacturer and complying with all applicable regulations and codes.

END OF SECTION

SUBMERSIBLE SUMP PUMP PUMPING SYSTEM  
33 32 26-2 (150826.40)

SECTION 33 42 13

PIPE CULVERTS

PART 1 - GENERAL

1.1 SUMMARY

- A. Provide pipe culverts as shown on the Drawings, as specified herein, and as needed for a complete and proper installation.
- B. Related work:
  - 1. Documents affecting work of this Section include, but are not necessarily limited to, General Conditions, Supplementary Conditions, and Division 01 - General Requirements of these Specifications.
- C. References:
  - 1. Reserved.

1.2 SUBMITTALS

- A. Shop Drawing Submittals – None Required.
- B. Operation and Maintenance Manuals – None Required.
- C. Certificates and Guarantees – None Required.
- D. Lubricants – None Required.
- E. Spare Parts – None Required.

1.3 QUALITY ASSURANCE – Reserved.

1.4 DELIVERY, STORAGE, AND HANDLING

- A. Comply with pertinent provisions of Section 01 66 11.

1.5 SITE CONDITIONS – Reserved.

1.6 MAINTENANCE – Reserved.

PART 2 - PRODUCTS

2.1 PIPE AND FITTINGS

- A. Corrugated metal pipe (CMP):
  - 1. Fabricate pipe from hot-dipped galvanized steel or aluminized steel conforming to AASHTO M 36.

2. Minimum thickness of pipe:
  - a. For pipe diameter or span 21" and smaller: 16 gauge, or 0.064".
3. Fabricate connecting bands from the same material, gauge, and pattern of corrugation as the pipe.
4. Metal apron endwalls for corrugated metal pipe shall be manufactured in accordance with the pertinent requirements specified for Corrugated Metal Pipe and shall be in accordance with the designs, dimensions, and details shown on the City of Madison Standard Detail Drawing 5.4.1, apron endwalls and the project Drawings.

## PART 3 - EXECUTION

### 3.1 SURFACE CONDITIONS

- A. Examine the areas and conditions under which work of this Section will be performed. Correct conditions detrimental to timely and proper completion of the Work. Do not proceed until unsatisfactory conditions are corrected.

### 3.2 FIELD MEASUREMENTS

- A. Make necessary measurements in the field to assure precise fit of items in accordance with the Drawings.

### 3.3 PIPE INSTALLATION

- A. General:
  1. Trench, backfill, and compact for the work of this Section in accordance with pertinent provisions of Section 31 23 79 except sand may be used for pipe culvert bedding and covering.
  2. Install pipe in accordance with pipe manufacturer's recommendations.
  3. Lay pipe by proceeding upgrade with the spigot ends of bell-and-spigot pipe pointing in direction of flow.
  4. Lay each pipe accurately to the indicated line and grade, aligning so the pipe has a uniform invert.
  5. Continually clear interior of the pipe free from foreign material.
  6. Before making pipe joints, clean and dry all surfaces of the pipe to be joined.

END OF SECTION

## SECTION 40 90 10

## PROCESS CONTROL SYSTEM FOR WATER SYSTEM FACILITIES

## PART 1 - GENERAL

## 1.1 SUMMARY

- A. Provide necessary control system components for integration of the new elevated tank as shown on the Drawings, as specified herein and as needed for a complete and functional installation, equal to existing elevated tank facilities for Madison Water Utility.
- B. Related work:
  - 1. Documents affecting work under this Section include, but are not necessarily limited to, General Conditions, Supplementary Conditions, and Division 01 – General Requirements of these Specifications.
- C. Work under this Section includes:
  - 1. Providing and programming the following:
    - a. Complete Supervisory Control and Data Acquisition (SCADA) System.
  - 2. Instrumentation (as outlined in Division 40 and Section 33 16 19.33).
  - 3. Antenna supports and antenna equipment.
  - 4. Communication between the SCADA master station and the RTU including radio transmission and receiving provisions, with at least one radio.
  - 5. Back-up power supply provisions for up to 8 hours.
  - 6. All required PLC programming requirements.
  - 7. Security Cameras and Access Control provisions.
  - 8. DVR viewing and back-up recording for security cameras for period of 24-hour loop.
  - 9. Providing calibration, commissioning and start-up of the entire control and monitoring system.
  - 10. Providing 8 hours of on-site training to the water operator(s).
  - 11. Ability to connect to future fiber optic communications.
  - 12. All power and control wiring (as part of this contract or subcontracted with electrical subcontractor).
  - 13. All required penetrations (as part of this contract and coordinated with tank manufacturer, or as part of this contract and subcontracted out to another subcontracted).
- D. References:
  - 1. Reserved.

## 1.2 SUBMITTALS

- A. Shop Drawing Submittals – None Required.

- B. Operation and Maintenance Manuals – None Required.
- C. Certificates and Guarantees – None Required.
- D. Spare Parts – None Required.
- E. Submit a test protocol document which is to be used to record test results demonstrating the instrumentation and control system operates as designed, a minimum of two (2) weeks prior to installation testing (commissioning). Documentation includes but is not limited to the following:
  - 1. Detailed test procedure.
  - 2. Checklists.
  - 3. Blank forms and data to be recorded.
  - 4. Test equipment to be used and calculated tolerance limits.
- F. Submit completed test protocol document after installation testing has been completed certifying system functions as specified.

### 1.3 QUALITY ASSURANCE

- A. Provide the services of Madison Water Utility's System Integrator "Altronex" who has the expertise to integrate the approved hardware and software with components from various manufacturers to present the Owner with a total system solution for the control and monitoring of the water system facilities.

### 1.4 DELIVERY, STORAGE, AND HANDLING

- A. Comply with pertinent provisions of Section 01 66 11.

### 1.5 SITE CONDITIONS – Reserved.

### 1.6 MAINTENANCE – Reserved.

## PART 2 - PRODUCTS

### 2.1 SCADA SYSTEM

- A. Upgrade and modify the existing Supervisory Control and Data Acquisition (SCADA) System to provide control, monitoring, alarming and reporting functions for the water system facilities.
  - 1. Consult with the Owner for the following:
    - a. To determine type and layout of SCADA graphic screens representing the water system facilities process equipment.
    - b. To determine which alarms should notify operators via alarm notification software.
    - c. To determine phone list(s) and scheduling for alarm notification software.



- d. To determine the specific format and information displayed for each report.
- e. To determine the number of security password levels required for operations.

## 2.2 SCADA SERVER PROGRAMMING

- A. Provide simple and intuitive navigation system to branch to other screens, including but not limited to the following:
  - 1. Process overview status screen.
  - 2. Detailed individual process status screens.
  - 3. Control/setpoint entry screens.
  - 4. Water level and pressure screens.
  - 5. Trend screens.
  - 6. Communication status screens.
  - 7. Alarm status screen.
  - 8. Alarm history screen.
- B. Provide graphic screens to display the entire water system status including valve position, pumps, motors, solenoids, instruments, equipment, etc.
- C. Provide consistent color scheme to indicate equipment status.
  - 1. Green = "On" or "Open".
  - 2. Background or neutral color = "Off" or "Closed".
  - 3. Yellow = Required to operate, but not yet running.
  - 4. Blink Red = unacknowledged alarm.
  - 5. Solid Red = acknowledged alarm.
- D. Provide consistent color scheme to distinguish between operator adjustable control setpoints and view-only value displays.
- E. Provide data entry and control parameter adjustment screens to enter alarm setpoints, control setpoints, and select control sequence parameters.
- F. Provide communication network status screen.
- G. Provide Power Management screen to display data from Power Monitors such as voltage, current, power, etc.
- H. Provide security passwords to access control and data entry screens.
- I. Indicate if data setpoints entered are out of range and do not change setpoint to new value.
- J. Configure computer screens using 3-dimensional rendering, "Reichard Software" or similar graphic symbols.
- K. Display the alarm conditions as described elsewhere in this section.

## 2.3 GENERAL ALARM INDICATION

- A. Display the alarm conditions on the following alarm screens at the SCADA Computers:
  - 1. Alarm history screen.
  - 2. Alarm status screen (showing active alarms only).
  - 3. Pop-up alarm message window.
- B. Provide alarm indication with the following detail:
  - 1. Time alarm occurred.
  - 2. Time alarm was acknowledged.
  - 3. Time alarm cleared.
  - 4. Location and/or equipment name.
  - 5. Alarm description.

## 2.4 INTRUSION ALARM CONTROL

- A. Reactivate PLC programming to initiate an intrusion alarm if an intrusion detection device is activated.
- B. Provide graphic screen at the SCADA computer to show the following:
  - 1. Status of each sensing device (active/not active).
  - 2. Status of each arm/disarm switch.
  - 3. Status of each intrusion alarm.
- C. Provide ability to acknowledge alarm only at the SCADA computer via password protected screen.

## 2.5 FIRE ALARM CONTROL

- A. Provide PLC programming to initiate a fire alarm if a heat or smoke detector is activated.
- B. Provide graphic screen at the SCADA computer to show the fire alarm status.

## 2.6 PROCESS CONTROL PANELS AND HARDWARE

- A. Provide control panels in conjunction with new MCC.

## 2.7 SECURITY CAMERAS

- A. Provide exterior and interior security cameras, required power to cameras, output signal cabling back to Control Panel cabinet, mounting of cameras and cabling, coordination with tank contractor, DVR recording and on-site viewing of camera recordings, future fiber connection provisions, plus all current internal networking hardware, connections and software.
- B. Security cameras to be as follows:
  - 1. Exterior; Axis P1427-LE, Bullet Style.

2. Interior; Axis P3225-LVE MK II, Domed Style.
3. Acceptable local provider to be Integral Building Systems, Inc., Madison WI, Kevin Judd, 608-467-9193.

C. Cabling to meet or exceed Category 6 cable requirements.

## 2.8 ACCESS CONTROL

A. Provide access control door swipe requirements for exterior personnel door on first floor including, required power to door swipe, cabling back to Control Panel cabinet, coordination with door subcontractor and tank contractor, mounting of door swipe, future fiber connection provisions, plus all current internal networking hardware, connections and software.

B. Door swipe to be as follows:

1. Keyscan access control consisting of:
  - a. KPROX 2 card reader.
  - b. Electric strike and recessed door contact.
  - c. CA150 Control panel with PoE power.
2. Acceptable local provider to be Integral Building Systems, Inc., Madison WI, Kevin Judd, 608-467-9193.

C. Cabling to meet or exceed system requirements.

## 2.9 PROCESS INSTRUMENTATION AND CONTROL

A. Provide process instrumentation and control features in compliance with Section 40 91 10 and Section 33 16 19.33.

## PART 3 - EXECUTION

### 3.1 INSTALLATION

A. Install remote control and telemetry features for a complete functional system with the Utility's Master SCADA system utilizing radio telemetry and future fiber optic system.

B. All power and control wiring (as part of this contract or subcontracted with electrical subcontractor).

C. All required penetrations (as part of this contract and coordinated with tank manufacturer, or as part of this contract and subcontracted out to another subcontracted).

D. Coordination with door subcontractor, electrical contractor, security camera and access control subcontractor, plus tank contractor.

### 3.2 START-UP AND TESTING

A. Start-up and testing is responsibility of system integrator.

- B. Provide calibration of all equipment and signals prior to start-up and testing.
- C. Notify Owner and Engineer two (2) days prior to on-site start-up.
- D. Perform start-up and testing in accordance with Section 01 91 58, FACILITY START-UP.
- E. In the presence of the Owner and Engineer, perform commissioning of the system after the contractor has tested the equipment and its appurtenances for proper operating condition, start-up has been performed, and Contractor feels system is ready to be placed into operation. Commissioning includes the following:
  - 1. Testing of operational control of entire system, which includes:
    - a. System interlocks and controls.
    - b. Equipment status.
    - c. Alarm functions.
    - d. Password and security functions.
  - 2. Emergency shutdown and restarting of the system.
  - 3. Provide report after testing has been completed certifying system functions as specified.
- F. Operational test after commissioning:
  - 1. The control and monitoring system is to operate without failure prior to Substantial Completion.
  - 2. Engineer and Contractor will agree to the start date for the 14-day operational test.
  - 3. Any failure in the system will require correction by the Contractor. If the failure causes shutdown of the system for more than 12 hours, the failure will be considered as a major and a new starting date for the 14-day operational test will be determined.
    - a. Submit a major malfunction report which will include details concerning the nature of the malfunction and the resulting repair action required and taken.
- G. Provide two (2) man-days of on-site non-warranty programming modification time in two trips after Substantial Completion of the Contract.

### 3.3 TRAINING

- A. Provide eight (8) hours total of on-site formal training in two trips of the Owner's operating personnel prior to substantial completion, to include, but not be limited to the following:
  - 1. Emergency shutdown and re-start up of the system.
  - 2. Complete hands-on familiarization with the process control software functions, including but not limited to the following:
    - a. Location of equipment status and process value indications.
    - b. Adjustment of setpoints and equipment control parameters.
    - c. Backup equipment operation when primary sensing devices/instruments are out of service.
    - d. Security.

3. Procedure for manual operating equipment when the SCADA computer, HMI or PLC fail or are out of service.
4. Alarm management.
5. Report generation.
6. Back-up procedures.

END OF SECTION

## SECTION 40 91 10

## PROCESS INSTRUMENTATION AND CONTROL SCHEDULE

## PART 1 - GENERAL

## 1.1 SUMMARY

- A. Provide process instrumentation as shown on the Drawings, as specified herein and as needed for a complete and proper installation.
- B. Related work:
  - 1. Documents affecting work under this Section include, but are not necessarily limited to, General Conditions, and Sections in Division 01 of these Specifications.
  - 2. Comply with the requirements of Division 26 for any electrical work related to work in Division 40.
- C. Work under this Section includes:
  - 1. Providing, programming, and control aspects of process instrumentation.
  - 2. Providing calibration, commissioning and start-up of the process instrumentation.
  - 3. Providing on-site training to the water operator.
- D. References:
  - 1. Reserved.

## 1.2 SUBMITTALS

- A. Shop Drawing Submittals – None Required.
- B. Operation and Maintenance Manuals – None Required.
- C. Certificates and Guarantees – None Required.
- D. Lubricants – None Required.
- E. Spare Parts – None Required.

1.3 QUALITY ASSURANCE – Reserved.

1.4 DELIVERY, STORAGE, AND HANDLING – Reserved.

1.5 SITE CONDITIONS – Reserved.

1.6 MAINTENANCE – Reserved.

## 1.7 ENVIRONMENTAL REQUIREMENTS

- A. Conform to sections of Division 01 during and after installation of the process instrumentation.

## PART 2 - PRODUCTS

### 2.1 PROCESS INSTRUMENTATION

- A. Liquid Process Measurement:
- Provide Liquid Pressure Process Measurement Devices to comply with Section 40 91 19.29 as follows:

Tag	General Description	Loop Powered	Calibration Range	Output mAdc
PT-SYS	Monitors System Pressure in Pressure Zone (PZ11) (Level readout at unit).	24Vdc	0/100 psi	4/20
PT-ET	Monitors water level in elevated tank (Level readout at Control Panel)	24Vdc	0/15 psi	4/20

- Auxiliary float level notes:

Tag	Control Description
FS-HWL	Provides high level pre-overflow alarm/indication water levels within elevated tank.
FS-ML	Provides mid-level indication for water levels within elevated tank.
FS-LL	Provides normal low-level indication for water levels within elevated tank.

- Process Switches to comply with Section 40 97 96, including low temperature alarm, door intrusion, flood floats, overflow flow switch, smoke/fire alarm.

### 2.2 PROCESS EQUIPMENT CONTROL

- A. Blackhawk Water Tower and Elevated Tank 126 Altitude Valves:

- Altitude Valve Position (Section 22 19 23) notes:

Tag	Control Description
BHT-AV	Open/Closed position based on 24 V limit switch, provided by valve manufacturer.
ET126-AV	Open/Closed position based on 24 V limit switch provided by valve manufacturer.

## PART 3 - EXECUTION

### 3.1 INSTALLATION

- A. Install the process instrumentation devices in accordance with manufacturer's recommendation.

- B. Install identification tags to comply with Section 26 05 53 and as follows:
  - 1. Provide metal tags to field instruments.
  - 2. Provide engraved plastic tags at MCC equipment.
- C. Identify all wires at both ends with wire markers to comply with Section 26 05 19. Show these numbering on the as-build drawings.
- D. Ground the shield of instrumentation controls cable at one end only (control panel). Insulate the shield at the other end from the ground.
- E. Touch-up and clean enclosures after the start-up.

### 3.2 START-UP AND TESTING

- A. Start-up and testing is responsibility of equipment supplier.
- B. Provide calibration of all equipment and signals prior to start-up and testing.

### 3.3 TRAINING

- A. Provide eight (8) hour training sessions of on-site formal training of the Owner's operating personnel prior to substantial completion, to include, but not be limited to, the following:
  - 1. Complete hands-on familiarization with the process instrumentation devices functions related to the application.

END OF SECTION



SECTION 40 91 19.29

LIQUID PRESSURE PROCESS MEASUREMENT DEVICES

PART 1 - GENERAL

1.1 SUMMARY

- A. Provide liquid pressure process measurement devices as shown on the Drawings, as specified herein, and as needed for a complete and proper installation.
- B. Related work:
  - 1. Documents affecting work of this Section include, but are not necessarily limited to, General Conditions, Supplementary Conditions, and Division 01 - General Requirements of these Specifications.
- C. References:
  - 1. Reserved.

1.2 SUBMITTALS

- A. Shop Drawing Submittals:
  - 1. Manufacturer's detailed specifications.
- B. Operation and Maintenance Manuals: Submit operation and maintenance manuals in compliance with pertinent provisions of Section 01 78 26.
- C. Certificates and Guarantees – None Required.
- D. Lubricants – None Required.
- E. Spare Parts – None Required.

1.3 QUALITY ASSURANCE – Reserved.

1.4 DELIVERY, STORAGE, AND HANDLING

- A. Comply with pertinent provisions of Section 01 66 11.

1.5 SITE CONDITIONS – Reserved.

1.6 MAINTENANCE – Reserved.

PART 2 - PRODUCTS

2.1 PRESSURE INDICATOR TRANSMITTER

- A. Design pressure/level indicator transmitter to sense and transmit water pressure/level.

- B. Provide pressure transmitter with the following requirements:
  - 1. Transducer to be an integrated circuit sensor type with true gauge pressure reading by venting of reference side of sensor to atmosphere.
  - 2. Primary fill-fluid: Silicone 200.
  - 3. Diaphragm material: 316 stainless steel.
  - 4. Process Connection: 1/2" NPT.
  - 5. Mounting bracket: 1-1/4" to 2" pipe or surface mounting as required.
  - 6. Integral indicator: Local indicator with minimum 3-1/2 digit LCD meter.
  - 7. Damping: Adjustable up to 15 seconds minimum.
  - 8. Adjustment: Integral zero and span adjustments.
  - 9. Power Supply: Loop power 24 Vdc.
  - 10. Output: 4-20 mAdc.
  - 11. Transient protection as required.
  - 12. Block and bleed manifold.
  - 13. Enclosure: NEMA 4X.
  
- C. Provide remote diaphragm seals with the following requirements:
  - 1. Fluid: Silicone 200.
  - 2. Diaphragm size: 4-inch, 316 stainless steel.
  - 3. Capillary: 316 stainless steel armor capillary.
  
- D. Provide pressure sensor isolator ring as required to comply with Section 40 97 96.
  
- E. Acceptable manufacturers:
  - 1. Foxboro, Model IGP10-A22D1F.
  - 2. Or approved equal.

## PART 3 - EXECUTION

### 3.1 INSTALLATION

- A. Install equipment in accordance with manufacturer's recommendations.

### 3.2 CALIBRATION

- A. Calibrate and program equipment to meet system requirements.

### 3.3 START-UP AND TESTING

- A. Comply with the manufacturer's recommended testing procedures.

END OF SECTION

SECTION 40 91 23.36

LEVEL PROCESS MEASUREMENT DEVICES

PART 1 - GENERAL

1.1 SUMMARY

- A. Provide level process measurement devices as shown on the Drawings and as specified herein.
- B. References:
  - 1. Reserved.

1.2 SUBMITTALS

- A. Shop Drawing Submittals:
  - 1. Manufacturer's detailed specifications.
- B. Operation and Maintenance Manuals: Submit operation and maintenance manuals in compliance with pertinent provisions of Section 01 78 26.
- C. Certificates and Guarantees – None Required.
- D. Lubricants – None Required.
- E. Spare Parts – None Required.

1.3 QUALITY ASSURANCE – Reserved.

1.4 DELIVERY, STORAGE, AND HANDLING

- A. Comply with pertinent provisions of Section 01 66 11.

1.5 SITE CONDITIONS – Reserved.

1.6 MAINTENANCE – Reserved.

PART 2 - PRODUCTS

2.1 SUBMERSIBLE HYDROSTATIC LEVEL TRANSMITTER

- A. The liquid level of the elevated tank shall be sensed by a submersible level transducer. The transducer shall be a **KPSI Series 750 Submersible Non-fouling Level Transmitter, or equal**. The transducer shall be of the head-pressure sensing type, suitable for continuous submergence and operation and shall be installed in accordance with manufacturer's instructions. The bottom diaphragm face of the

sensor shall be installed 6 inches above the floor. The sensor shall be mounted using a 316 stainless steel cable and weight system; location to be determined in the field.

- B. The transducer shall sense water level (pressure) variations and transform these variations directly into a standard process signal of 1 to 5 volts DC or 4-20 mA over the desired level range (span). The transducer shall be completely solid state, with no mechanical linkages or moving parts. Supply voltage shall be as required by Contractor.
- C. The transducer shall include easily accessible offset and span adjustments. Span shall be adjustable from 100% down to 15% of the sensor range. Fine and coarse adjustments for both span and offset shall be provided using 25-turn potentiometers. Offset and span adjustments shall be non-interactive for ease of calibration. Operating pressure range of the transducer shall be between 0 to 15 psig.
- D. Submersible level transmitter shall be mounted on a stainless steel cable with PVC covered anchor and mounted per manufacturer's instructions. All mounting hardware shall be stainless steel and provided with transmitter.
- E. Mounting location to be at water containment access hatch located above elevated tank with approximately 50' of required control cabling. Include stainless steel eyebolt with "D-ring" connection.
- F. Provide minimum 12" by 8" by 8" stainless steel junction box outside access hatch for termination of power and control cabling. Cabling to extend from device to junction box and then from junction box to SCADA Control Panel via access tube. Coordinate penetrations of access tube and access hatch with Tank Contractor.
- G. Control cabling from junction box to SCADA Control Panel to be minimum 4 wire Belden cable.
- H. Provide local read-out of tank level at SCADA Control Panel located at base of elevated tank.

## 2.2 FLOAT SWITCHES

- A. Float switches when specified herein, shown on the drawings, or necessary to complete an operating system shall be as follows:
  - 1. The float switches shall be mercury free and consist of a 316 stainless steel housing 5½-inch diameter, stainless steel mounting clamp, a flexible two-conductor cable with a CPE jacket, and a potted SPST magnetic reed switch. Provide switch configuration (NO or NC) as required. The electrical load for the switch contacts shall be 100 VA at up to 250 volts. Float switches shall include a two-conductor cable 16 AWG with fine strands made for heavy flexing service and underwater use. Cable length shall provide for a continuous run to the terminating control panel where possible. A green grounding wire shall connect internally to the float housing. Floats shall be **Anchor Scientific Roto Float SSTNM, Type W, or equal.**

2. Weight and buoyancy shall be such that contaminants will not result in the float switch changing operating level more than 1-inch.
  3. Operating temperature range shall be -31° to 194°F.
  4. Provide three floats for insertion in elevated tank with depth of up to 40 feet below top of hatch with water level depth of up to 35 feet. Floats shall sense 3 independent depths and controls as follows:
    - a. Overflow High Water Level (Alarm); 2' below overflow elevation.
    - b. Middle Level (Alarm); 8' below overflow elevation.
    - c. Normal Low Water Level (Alarm); 17' below overflow elevation.
- B. Floats shall be provided with stainless steel cable with PVC covered anchor per manufacturer's instructions. All mounting hardware shall be stainless steel and provided. Mounting location to be at water containment access hatch located above reservoir pilaster and ladder.
- C. Provide stainless steel Kellems grips for each float cable. Include stainless steel eyebolt with "D-ring" connection.
- D. Utilize stainless steel junction box provided for submersible level transmitter outside of access hatch for termination of control cabling for floats. Cabling to extend from device to junction box and then from junction box to SCADA Control Panel via access tube. Coordinate penetrations of access tube and access hatch with Tank Contractor.
- E. Control cabling from junction box to SCADA Control Panel to be minimum 4 wire Belden cable.

## PART 3 - EXECUTION

### 3.1 INSTALLATION

- A. Provide power and control cabling for transducer and level floats from SCADA Control Panel to devices through stainless steel junction box located on top of elevated tank. Penetrate water containment tank through water tight fittings installed through access tube and tank access hatch. Coordinate locations and sizes of access tube penetrations with tank manufacturer.
- B. Install equipment in accordance with manufacturer's recommendations.

### 3.2 CALIBRATION

- A. Calibrate and program equipment to meet system requirements.
- B. Integrate into control system to provide noted system control.

### 3.3 START-UP AND TESTING

- A. Comply with the manufacturer's recommended testing procedures.

END OF SECTION

SECTION 40 94 27

DISTRIBUTED INPUT/OUTPUT (DIO) DEVICES

PART 1 - GENERAL

1.1 SUMMARY

- A. Provide distributed input/output (DIO) devices as needed for a complete and proper installation.
- B. Related work:
  - 1. Documents affecting work of this Section include, but are not necessarily limited to, General Conditions, Supplementary Conditions, and Division 01 - General Requirements of these Specifications.
- C. References:
  - 1. Reserved.

1.2 SUBMITTALS

- A. Shop Drawing Submittals:
  - 1. Manufacturer's detailed specifications.
- B. Operation and Maintenance Manuals: Submit operation and maintenance manuals in compliance with pertinent provisions of Section 01 78 26.
- C. Certificates and Guarantees - Reserved.
- D. Spare Parts:
  - 1. Provide one spare module for each unique module supplied, including power supply, I/O module, and adapter.

1.3 QUALITY ASSURANCE

- A. Provide all equipment by one manufacturer.

1.4 DELIVERY, STORAGE, AND HANDLING

- A. Comply with pertinent provisions of Section 01 66 11.

1.5 SITE CONDITIONS – Reserved.

1.6 MAINTENANCE – Reserved.

1.7 ENVIRONMENTAL REQUIREMENTS

- A. Maintain area free of dirt and dust during and after installation of products.

DISTRIBUTED INPUT/OUTPUT (DIO) DEVICES

40 94 27-1 (150826.40)

## PART 2 - PRODUCTS

### 2.1 GENERAL

- A. Design distributed I/O devices to accept input contact and analog signals, perform the functions through remote Programmable Logic Controller (PLC), and output contact and analog signals to control and/or indicate the specified process.
- B. Provide modular distributed I/O system consisting of adapter, terminal base and I/O modules.
- C. Provide stand-alone distributed I/O devices for installation in Motor Control Centers and/or Variable Frequency Drives.

### 2.2 MODULAR DISTRIBUTED I/O DEVICES

- A. Provide adapter module to power the internal logic of up to eight I/O modules and communicate with the PLC via one of following networks as shown on the Drawings:
  - 1. DeviceNet.
  - 2. ControlNet.
  - 3. Ethernet/IP.
  - 4. Remote I/O.
- B. Provide terminal base for termination of field wiring to the I/O module.
- C. Provide 120VAC or 24VDC discrete input module with 8 or 16 photo-optically isolated inputs.
- D. Provide discrete output module with the following requirements:
  - 1. Minimum 8 relay type output points with each relay contact rated at 2.0A continuous, 120 VAC.
  - 2. Provide surge suppression components across each output device, per manufacturer's recommendation.
- E. Provide analog input module with a minimum of 4 input channels selectable for a 4-20 mAdc current input, with current input impedance of 160 ohms per channel.
- F. Provide analog output module with a minimum of 4 output channels selectable for a 4-20 mAdc current output and load of 500 ohms.
- G. Provide 24VDC power supply to power adapter modules as required.
- H. Provide SCANport module to interface to related SCANport devices.
- I. Acceptable manufacturers:
  - 1. Allen Bradley Flex I/O.

2. Or equal.

### 2.3 STAND-ALONE DISTRIBUTED I/O DEVICES

- A. Provide DeviceNet System Accessory (DSA) module with following requirements.
  1. Inputs: Minimum two, 24 Vdc.
  2. Outputs: Minimum one relay, rated at 250V.
  3. Acceptable manufacturers:
    - a. Allen-Bradley.
    - b. Or equal.
- B. Provide SCANport to DeviceNet communication module to function as a gateway between DeviceNet and SCANport devices while providing discrete inputs.
  1. Acceptable manufacturers:
    - a. Allen-Bradley, 2100-GK61.
    - b. Or equal.

## PART 3 - EXECUTION

### 3.1 INSTALLATION

- A. Install distributed I/O devices in accordance with manufacturer recommendations.
- B. Install component identification and wire tags on all wiring.

### 3.2 START-UP AND TESTING

- A. Comply with the manufacturer's recommended procedures.

### 3.3 CLEANING

- A. Clean units as recommended by manufacturer.

END OF SECTION



## SECTION 40 94 43

## PROGRAMMABLE LOGIC PROCESS CONTROLLERS

## PART 1 - GENERAL

## 1.1 SUMMARY

- A. Provide programmable logic process controllers as specified herein, and as needed for a complete and proper installation.
- B. Related work:
  - 1. Documents affecting work of this Section include, but are not necessarily limited to, General Conditions, Supplementary Conditions, and Division 01 - General Requirements of these Specifications.
- C. References:
  - 1. Reserved.

## 1.2 SUBMITTALS

- A. Shop Drawing Submittals:
  - 1. Manufacturer's detailed specifications.
- B. Operation and Maintenance Manuals: Submit operation and maintenance manuals in compliance with pertinent provisions of Section 01 78 26.
- C. Spare Parts:
  - 1. Package all spare parts and label all packages with quantity, item description, and part number.
  - 2. Provide the following number of spare parts to the Owner that match items specified:
    - a. One spare processor unit for each unique processor installed.
    - b. One spare I/O Module for each unique I/O module type installed.
    - c. One spare communication module for each unique communication module installed.
    - d. One spare power supply for each unique power supply installed.

## 1.3 QUALITY ASSURANCE

- A. Provide all equipment by one manufacturer.

## 1.4 DELIVERY, STORAGE, AND HANDLING

- A. Comply with pertinent provisions of Section 01 66 11.

## 1.5 SITE CONDITIONS – Reserved.

1.6 MAINTENANCE – Reserved.

1.7 ENVIRONMENTAL REQUIREMENTS

- A. Maintain area free of dirt and dust during and after installation of products.

## PART 2 - PRODUCTS

### 2.1 GENERAL

- A. Design Programmable Logic Controller (PLC) to accept input contact and analog signals, perform the functions specified, and output contact and analog signals to control and/or indicate the specified processes.
- B. Provide rack-mounted style PLC consisting of I/O racks, power supplies, CPUs, memory units, network communication modules and I/O modules.
1. Provide a modular type system with the necessary number and type of inputs and outputs.
  2. Noise immunity to meet NEMA Standard ICS2-230.
  3. Rack-mounted module removable without disconnecting the wiring harness from its terminals.
  4. Provide expansion racks and power supplies at each location as required.
  5. Provide rack interconnect cables as required noting location of keyed plugs.
- C. Provide micro style PLC consisting of base unit with integral I/O, processor and power supply. Provide expansion I/O modules and network communication modules as required.
- D. Provide DIN rail mounted style PLC consisting of CPUs, power supplies, memory units, network communication modules and I/O modules.
1. Provide a modular type system with the necessary number and type of inputs and outputs.
  2. Provide expansion modules and power supplies at each location as required.
  3. Provide expansion module interconnect cables as required.

### 2.2 RACK-MOUNTED PROGRAMMABLE LOGIC CONTROLLER

- A. Provide I/O rack with the following requirements:
1. Modular style slotted mounting rack to support the power supply, CPU, and I/O modules.
  2. A minimum of two (2) spare slots after fully configured.
  3. Allows modules to slide into the racks along guides, without use of tools.
- B. Provide power supply with the following requirements:
1. Mounted on the side of each of the racks to power the CPU and I/O modules.
  2. Replaceable fuse and AC voltage selection jumper located for 120 VAC, 60 Hertz.
  3. Sized to accommodate the full load capacity of the rack including spare slots.

- C. Provide Central Processing Unit (CPU) with the following requirements:
  - 1. Minimum 16K program memory and capable of controlling up to 4096 input and output points.
  - 2. Integral communication ports:
    - a. One RS-232.
    - b. One Ethernet, DH+, or DH-485 as shown on the Drawings.
  - 3. Lithium battery backed RAM user memory.
  - 4. Flash EPROM or EEPROM memory backup.
  - 5. Ability to program on-line or off-line.
  - 6. Embedded proportional-integral-derivative (PID) instruction.
- D. Provide memory unit with the following requirements:
  - 1. Flash EPROM or EEPROM non-volatile memory backup unit.
  - 2. Minimum 16K memory capacity.
  - 3. Ability to save the contents of the CPU RAM (Random Access Memory) for storage purposes and load the contents of the Flash EPROM or EEPROM back into the processor RAM.
- E. Provide 120 VAC or 24 VDC discrete input modules with 4, 8, or 16 photo-optically isolated inputs.
- F. Provide discrete output modules with the following requirements:
  - 1. Minimum 8 individually isolated relay type output points with each relay contact rated at 5A continuous, 120 VAC.
  - 2. Surge suppression component across each output, per manufacturer's recommendation.
- G. Provide high speed counter or flow meter input modules with minimum 4 input channels:
  - 1. Acceptable manufacturers: Spectrum Controls or equal.
- H. Provide analog input module with a minimum of 4 input channels selectable for a 4-20 mAdc current input, and input impedance of 250 ohms per channel.
- I. Provide analog output module with a minimum of 4 output channels selectable for a 4-20 mAdc current output and output impedance of 500 ohms per channel.
- J. Provide communication modules as required:
  - 1. DeviceNet Scanner with DeviceNet Redundant Power Supply.
  - 2. Remote I/O Scanner.
  - 3. Remote I/O Adapter.
  - 4. KE Module.
  - 5. Modbus communication module.
    - a. Acceptable manufacturers: Prosoft Technology or equal.
- K. Provide cables as required for connecting PLC to related devices.
- L. Acceptable manufacturers:
  - 1. Allen-Bradley: (SLC-5/05, SLC-5/04, SLC-5/03).

2. Or equal.

### 2.3 MICRO PROGRAMMABLE LOGIC CONTROLLER

- A. Provide micro style programmable logic controller with the following requirements:
  1. Base unit consisting of integrated power supply, processor unit and I/O termination points for a complete controller unit.
  2. Ability to expand I/O capacity by adding compact I/O modules.
  3. Communication ports:
    - a. One RS-232.
    - b. One RS-232 or Ethernet as shown on the Drawings.
  4. Minimum 4K user memory.
  5. Built-in PID instruction.
  6. Real time clock.
  7. Power source requirement: 120 VAC or 24 VDC.
  8. Minimum ten 120VAC or 24VDC discrete inputs embedded on base unit.
  9. Minimum six relay discrete outputs embedded on base unit.
- B. Provide expansion I/O modules as required:
  1. Discrete input modules: 16-point, 120VAC or 24VDC as required.
  2. Discrete output modules: 8-point relay output.
  3. Analog input modules: 4-channel, configurable for dc voltage or current.
  4. Analog output modules: 2-channel, configurable for dc voltage or current.
- C. Provide cables as required to connect PLC with related devices.
- D. Acceptable manufacturers:
  1. Allen-Bradley: MicroLogix 1500, MicroLogix 1200, or MicroLogix 1100.
  2. Or equal.

### 2.4 DIN RAIL MOUNTED PLC

- A. Common Hardware Ratings:
  1. Operating Temperature range: 0°C to +55°C.
  2. Storage Temperature range: -40°C to +85°C.
  3. Humidity range: 5 to 95% non-condensing.
  4. Noise Immunity in compliance to NEMA Standard ICS 2-230.
  5. Operation Vibration Rating: 5.0 G at 10 to 500Hz, 0.030-inch peak-to-peak.
  6. Isolation level: 1500V between backplane and I/O.
  7. Dielectric withstand rating: 1500V ac in compliance with UL 508, CSA C22.2 No. 142.
- B. Processor Unit:
  1. Program memory: 750K RAM, minimum.
  2. Capable of controlling up to (16) I/O modules.
  3. Proportional Integral Derivative Control with up to 451 microsecond execution time.
  4. Online programming including runtime editing.

5. Standard RAM Memory Back-up provided through minimum two-year lithium battery.
  6. LED indicators for: POWER, RUN, CPU Fault, Forced I/O, Battery Low, DH485, RS-232.
  7. Two communication ports:
    - a. One RS-232 port that supports DF1 full-duplex, DF1 half-duplex master and slave, and ASCII protocols.
    - b. One Ethernet port that supports Ethernet/IP protocol.
  8. Real Time Clock.
  9. Key Switch Positions for Remote, Program and Run.
- C. Discrete Input Modules:
1. Operating voltage: 79 to 132V AC.
  2. Sixteen (16) Non-isolated inputs or eight (8) isolated inputs as required.
  3. Removable terminal block.
  4. LEDs to indicate the status of each I/O point.
- D. Analog Input Modules:
1. Four (4) input channels per module.
  2. Ratings:
    - a. Current Rating: 0 to 20mAdc, 4 to 20mAdc.
    - b. Voltage Rating: Plus/Minus 10Vdc, 0 to 10Vdc, 0 to 5Vdc, 1 to 5Vdc.
  3. Terminal Impedance:
    - a. Current Rating: 250 Ohms.
    - b. Voltage Rating: 220Kohms.
  4. LEDs to indicate the status of each I/O point.
- E. Relay Output Modules (Isolated):
1. Voltage rating: 5 to 265 Vac.
  2. Eight (8) Individually Isolated Relay outputs.
  3. Continuous current rating per point: 2.5A ac not to exceed 1440 VA for the module.
  4. Continuous current rating per module: 16A ac, 2.5A/common.
  5. LEDs to indicate the status of each I/O point.
  6. Optical isolation between digital and field circuits.
- F. Analog Output Modules:
1. Two (2 ) output channels per module, single-ended.
  2. Ratings:
    - a. Current Rating: 0 to 20mA, 4 to 20mA.
    - b. Voltage Rating of Plus/Minus 10Vdc, 0 to 10Vdc, 0 to 5Vdc, 1 to 5Vdc.
  3. LEDs to indicate the status of each I/O point.
- G. Expansion Power Supply:
1. Line Voltage rating: 85 to 265 Vac.
  2. User Power Capacity: 250mA at 24Vdc.
  3. Short circuit protection via front access fuse with cover.
  4. Plus 5V and Plus 24V overvoltage protection.

- 5. LED to indicate that input power is available.
- H. Provide communication modules as required:
  - 1. DeviceNet scanner.
- I. Provide taps and cables as required for connecting PLC to related devices.
- J. Acceptable manufacturers:
  - 1. Allen-Bradley: CompactLogix.
  - 2. Or equal.

## 2.5 INTERFACE CONVERTERS

- A. Provide the following interface converters as required:
  - 1. DF-1 to DH-485 Converter.
  - 2. DF-1 to DeviceNet Converter.
  - 3. DF-1 to Ethernet Converter.

## PART 3 - EXECUTION

### 3.1 INSTALLATION

- A. Install PLC in accordance with manufacturer's recommendations.
- B. Cover all unused rack slots with card slot fillers.
- C. Install component identification and wire tags on all wiring.

### 3.2 PROGRAMMING

- A. Program PLC in accordance with manufacturer's instructions and as shown on the Drawings.

### 3.3 CLEANING

- A. Clean units as recommended by manufacturer.

END OF SECTION

## SECTION 40 95 13

## PROCESS CONTROL PANELS AND HARDWARE

## PART 1 - GENERAL

## 1.1 SUMMARY

- A. Provide process control panel and hardware as shown on the Drawings, as specified herein and as needed for a complete and proper installation.
- B. Related work:
  - 1. Documents affecting work under this Section include, but are not necessarily limited to, General Conditions, and Sections in Division 01 of these Specifications.
- C. Work under this Section includes:
  - 1. Providing pre-wired and programmed process control panels.
  - 2. Start-up and testing of the process control panels.
  - 3. Providing on-site training to the operations staff.

## 1.2 SUBMITTALS

- A. Shop Drawing Submittals:
  - 1. Control panels, components, PLC power supply loading calculations, UPS runtime calculation, sequence of operation description, and manufacturer's detailed specifications (cut-sheets or data sheets).
    - a. Each control panel supplier to submit documentation for all supplied control panels and components in one submittal package.
- B. Operation and Maintenance Manuals: Submit operation and maintenance manuals in compliance with pertinent provisions of Section 01 78 26.
- C. Certificates and Guarantees – None Required.
- D. Spare Parts – None Required.
- E. Submit control system drawings, including drawing index, bill of materials, control system configuration overview, panel dimensions and layouts, programmable logic controller (PLC) rack layouts, control wiring schematics, instrument loop diagrams, and panel/field interconnecting diagram.
  - 1. Submit the initial drawings on 11" x 17" sheets with the shop drawings.
  - 2. After the control and monitoring system is fully operational and all modifications have been made, submit the final as-built drawings as follows:
    - a. Four (4) printed copies on 11" x 17" sheets.
    - b. Four (4) electronic copies on CD-ROM compatible with AutoCAD.

## PROCESS CONTROL PANELS AND HARDWARE

40 95 13-1 (150826.40)

- F. Submit a factory or shop operational test report for each panel verifying hardware and functional requirements not less than 10 days prior to shipment of the panels.
- G. Submit PLC register mapping document listing data registers to be transmitted to other networked PLCs as shown on the Drawings or as specified elsewhere. Document to include register address, description, data format, and engineering units.
- H. Submit two (2) complete printed copies of the Human Machine Interface (HMI) graphic screen shots for each system, a minimum of two (2) weeks prior to start-up.
- I. Submit electronic copies of final programs and device configurations after Substantial Completion as follows:
  - 1. Four (4) CD-ROMS for each system prior to final completion. Documentation for multiple control panels can be provided on one CD. Provide the following documentation:
    - a. HMI application source code.
    - b. PLC application source code.
    - c. DeviceNet network device configuration file and electronic data sheet (EDS) files for connected devices.
    - d. Radio Transceiver configuration files.
    - e. All passwords and any other required information to configure any system component.

### 1.3 QUALITY ASSURANCE

- A. Assemble and wire all panels in factory or shop.
  - 1. Provide color-coded wiring in accordance with applicable codes and laws to facilitate maintenance and repair of control panel. Post color-coding schedule inside the control panel.
  - 2. Provide minimum 16 AWG control wires and provide spiral wrap, tie wrap, fasteners, and wire duct as required.
  - 3. Label all wiring at each end with numbers corresponding to the wiring schematics. Show numbering on the as-built drawings. Use tubular heat shrink-type or self-laminating vinyl wire markers printed using thermal printer.
  - 4. Label all terminal blocks with numbers corresponding to the wire numbers.
  - 5. Segregate wiring of different voltage levels.
  - 6. Provide nameplates for enclosure, instruments, devices and components. Descriptions on the nameplate to agree with the descriptions on the as-built drawings.
- B. Provide enclosures, devices, components, etc., which have been listed and labeled by Underwriter's Laboratories.
- C. Perform a factory or shop operational test on each panel.

### 1.4 DELIVERY, STORAGE, AND HANDLING

- A. Comply with pertinent provisions of Section 01 66 11.



- 1.5 SITE CONDITIONS – Reserved.
- 1.6 MAINTENANCE – Reserved.
- 1.7 ENVIRONMENTAL REQUIREMENTS
  - A. Conform to Sections of Division 01 during and after installation of the control and monitoring systems.
  - B. Maintain area, including enclosures, free of dirt and dust during and after installation of products.

## PART 2 - PRODUCTS

### 2.1 GENERAL

- A. Facilitate coordination between all processes to ensure seamless integration into the existing SCADA system where applicable.
- B. Provide PLC-based control panel to control and monitor the process equipment as specified in other Sections and as shown on the Drawings with the following requirements:
  - 1. Controller (processor) with adequate memory.
  - 2. Power supplies with adequate load capacity.
  - 3. Analog and discrete input/output modules to control and monitor all applicable signals required for proper operation.
  - 4. Communication modules to interface with the SCADA network and field devices.
  - 5. Human Machine Interface (HMI) with screen size as shown on the Drawings.

### 2.2 GENERAL PLC PROGRAMMING

- A. Provide time delays for motors, valves, alarms, etc. as follows:
  - 1. To prevent motors from starting at the same time when power is restored from power outage.
  - 2. To prevent false starts/stops or false alarm due to process spikes or input “bouncing”.
  - 3. To prevent the 3<sup>rd</sup> large pump from operating (even in the “hand” mode) when the generator is operating.
- B. Provide monitoring of analog signals to determine if the signals are out of range, and alarm the out of range conditions.
- C. Provide programming to retain the timing, control and alarm setpoints in the event the HMI goes offline.
- D. Annunciate and indicate process alarms, limit alarms, motor failures, PLC faults, and mechanical equipment failures at local HMI and transmit to SCADA Server.

- E. Provide programming to allow operator acknowledgement of alarms using either of the following two methods as determined by the Owner:
  - 1. Allow acknowledgement via the SCADA Server only after user login is entered and log information in log file. Send acknowledgement information to local HMI to acknowledge alarm in HMI after acknowledged at SCADA Server.
  - 2. Allow acknowledgement at SCADA Server or at local HMI without logging user information when acknowledged at local HMI.
- F. Provide programming to annunciate PLC fault, communication loss, and low battery alarm.

## 2.3 GENERAL HUMAN MACHINE INTERFACE (HMI) PROGRAMMING

- A. Provide simple and consistent navigation system to branch to other screens, including but not limited to the following:
  - 1. Process status screen.
  - 2. Control/setpoint entry screens.
  - 3. Alarm status screen.
  - 4. Alarm history screen.
- B. Provide graphic screens to display the process status.
- C. Provide consistent color scheme to indicate equipment status as follows:
  - 1. Green = "On".
  - 2. Background or neutral color = "Off".
  - 3. Yellow = Required to operate, but not yet running.
  - 4. Blink Red = unacknowledged alarm.
  - 5. Solid Red = acknowledged alarm.
- D. Provide consistent color scheme to distinguish between operator adjustable control setpoints and view-only value displays.
- E. Provide data entry and control parameter adjustment screens to enter alarm setpoints, control setpoints, and select control sequence and process parameters.
- F. Provide screen to indicate solid state motor overload relay over-current setting and allow setting adjustment via password protected screen.
- G. Provide security passwords for access to control and data entry screens.
- H. Indicate if data setpoints entered are out of range and do not change setpoint.
- I. Display the alarm conditions as described elsewhere in this section.

## 2.4 GENERAL ALARM INDICATION IN HMI

- A. Display the alarm conditions on the following alarm screens at the HMI:
  - 1. Alarm history screen.

2. Alarm status screen (showing active alarms only).
  3. Pop-up alarm message window.
- B. Provide alarm indication with the following detail:
1. Time alarm occurred.
  2. Time alarm was acknowledged.
  3. Time alarm cleared.
  4. Location and/or equipment name.
  5. Alarm description.

## 2.5 ENCLOSURES, DEVICES, COMPONENTS

- A. Comply with applicable Sections in Divisions 26 and 40 for all equipment supplied under this Section.
- B. Provide pre-wired controls housed in an enclosure consisting of but not limited to the following as applicable and as shown on the Drawings:
1. Programmable Logic Controller (PLC).
  2. Human Machine Interface (HMI).
  3. Power supply systems as follows:
    - a. Uninterruptible power supply (UPS).
    - b. Redundant DC Power Supplies.
    - c. Redundant DeviceNet power supplies.
  4. Fused terminal blocks for power supply to field instruments.
  5. Surge protection to protect the following:
    - a. Analog and discrete signals from field instruments.
    - b. Power supplies leaving the building.
    - c. Main 120 volt power feed to control panel.
  6. Alarm horn, selector switches, push buttons, pilot lights, and other operator devices.
  7. Intrinsically safe relays.
  8. Control relays.
  9. Thermal management system to maintain components at rated temperature.
  10. Lighting package with remote mounted door switch.
  11. Corrosion inhibitors.
  12. Terminal blocks for field wiring:
    - a. Finger-safe, DIN rail mounted, with separation plates, end barriers, and end anchors as required.

## PART 3 - EXECUTION

### 3.1 INSTALLATION

- A. Install process control panels in accordance with manufacturer's recommendation and as follows:
1. Terminate all wiring between field devices.
  2. Ground the shield of instrumentation controls cable at one end only. Insulate the shield at the other end from the ground.

- B. Install nameplates and identification tags to comply with Section 26 05 53 and as follows:
  - 1. Label the enclosures, devices, and components.
- C. Touch-up and clean enclosures after the start-up.

### 3.2 START-UP AND TESTING

- A. Start-up and testing is responsibility of the process control panel supplier.
- B. Provide start-up and testing of process control panels in conjunction with the equipment it controls and as specified in other Sections of these Specifications.

END OF SECTION

## SECTION 40 95 74

## PROCESS CONTROL SIGNAL CONDITIONERS/CONVERTERS

## PART 1 - GENERAL

## 1.1 SUMMARY

- A. Provide process control signal conditioners/converters as shown on the Drawings, as specified herein, and as needed for a complete and proper installation.
- B. Related work:
  - 1. Documents affecting work under this Section include, but are not necessarily limited to, General Conditions, Supplementary Conditions, and Division 01 - General Requirements of these Specifications.
- C. References:
  - 1. Reserved.

## 1.2 SUBMITTALS

- A. Shop Drawing Submittals:
  - 1. Manufacturer's detailed specifications.
- B. Operation and Maintenance Manuals: Submit operation and maintenance manuals in compliance with pertinent provisions of Section 01 78 26.
- C. Spare Parts:
  - 1. Package all spare parts and label all packages with quantity, item description, and part number.
  - 2. Provide one spare unit for each unique type of unit installed.

## 1.3 QUALITY ASSURANCE – Reserved.

## 1.4 DELIVERY, STORAGE, AND HANDLING

- A. Comply with pertinent provisions of Section 01 66 11.

## 1.5 SITE CONDITIONS – Reserved.

## 1.6 MAINTENANCE – Reserved.

## PART 2 - PRODUCTS

## 2.1 SIGNAL CONDITIONER (ISOLATOR)

- A. Provide a single output isolator with the following requirements:
  - 1. Input: 4 to 20 mA dc.

2. Output: Isolated 4 to 20 mAdc.
  3. Power supply: 120 Vac, 60 Hertz or loop powered.
  4. Mounting: Plug-in DIN rail socket.
- B. Provide a dual output isolator with the following requirements:
1. Input: One (1) 4 to 20 mAdc.
  2. Output: Two (2) isolated 4 to 20 mAdc.
  3. Power supply: 120 Vac, 60 Hertz or loop powered.
  4. Mounting: Plug-in DIN rail socket.
- C. Acceptable manufacturers:
1. Action Instruments.
  2. Absolute Process Instruments.
  3. Acromag.
  4. Or equal.

## 2.2 RESISTANCE TO CURRENT CONVERTER

- A. Provide potentiometer input signal converter to provide current output signal directly proportional to resistance input signal with the following requirements:
1. Input: Potentiometer resistance.
  2. Output: Isolated 4 to 20 mAdc.
  3. Power supply: 120 Vac, 60 Hertz.
  4. Mounting: Plug-in DIN rail socket.
- B. Acceptable manufacturers:
1. Action Instruments.
  2. Absolute Process Instruments.
  3. Acromag.
  4. Or equal.

## 2.3 CURRENT TO CURRENT CONVERTERS

- A. Provide current input signal converter to provide current output signal directly proportional to current input signal with the following requirements:
1. Input: 0 to 5 amps AC.
  2. Frequency range: minimum 48 to 65Hz.
  3. Output: 4 to 20 mAdc; minimum 500 Ohms.
  4. Power supply: 120 VAC, 60 Hertz.
  5. Accuracy: +- 0.25% F.S.
- B. Acceptable manufacturers:
1. Flex-Core.
  2. Or equal.

## 2.4 LIMIT ALARM

- A. Provide a single trip field configurable limit alarm with the following requirements:
1. Input: 4 to 20 mAdc.

2. Output: Single trip DPDT.
3. Power supply: 120 Vac, 60 Hertz or loop powered.
4. Mounting: Plug-in DIN rail socket.

- B. Acceptable manufacturers:
1. Action Instruments.
  2. Absolute Process Instruments.
  3. Acromag.
  4. Or equal.

## PART 3 - EXECUTION

### 3.1 INSTALLATION

- A. Install process control signal conditioners/converters in accordance with manufacturer's recommendations.

END OF SECTION

SECTION 40 95 88  
POWER SUPPLY SYSTEMS

PART 1 - GENERAL

1.1 SUMMARY

- A. When existing devices specified in Section 40 90 10 (2.7) cannot be re-used: Provide power supply systems as shown on the Drawings, as specified herein, and as needed for a complete and proper installation.
- B. Related work:
  - 1. Documents affecting work of this Section include, but are not necessarily limited to, General Conditions, Supplementary Conditions, and Division 01 - General Requirements of these Specifications.
  - 2. Comply with the requirements of Division 26 for any electrical work related to work in Division 40.
- C. References:
  - 1. Reserved.

1.2 SUBMITTALS

- A. Shop Drawing Submittals:
  - 1. Manufacturer's detailed specifications.
- B. Operation and Maintenance Manuals: Submit operation and maintenance manuals in compliance with pertinent provisions of Section 01 78 26.
- C. Certificates and Guarantees – None Required.
- D. Spare Parts – None Required.

1.3 QUALITY ASSURANCE – Reserved.

1.4 DELIVERY, STORAGE, AND HANDLING

- A. Comply with pertinent provisions of Section 01 66 11.

1.5 SITE CONDITIONS – Reserved.

1.6 MAINTENANCE – Reserved.



## PART 2 - PRODUCTS

### 2.1 UNINTERRUPTIBLE POWER SUPPLY

- A. Design uninterruptible power supply (UPS) to supply the total power requirement of the system plus 25 percent for future expansion.
1. Provide no-break transfer line to inverter and return.
- B. Provide UPS unit with the following requirements:
1. Input: 120 VAC 60 Hertz, single phase.
  2. Output: voltage 120 VAC 60 Hertz, single phase, true sine wave.
  3. Battery time: 30 minutes minimum of running time at full load or 60 minutes minimum at half load.
  4. Battery: Sealed, lead acid 5-year-maintenance free.
  5. Input/output configuration:
    - a. Input: 6-foot line cord with 20A, 3-prong grounded plug (5-20P).
    - b. Output: minimum 2-duplex, 15A receptacles.
  6. Safety: UL listed.
  7. Acceptable manufacturers:
    - a. American Power Conversion (APC), Smart UPS.
    - b. Sola/Hevy-Duty S4K Series.
    - c. Allen Bradley 1609 Series.
    - d. Or equal.
- C. Provide control panel UPS with relay interface card with dry contact relay outputs to monitor the following UPS status:
1. Battery On.
  2. Battery Low.
  3. Communication Loss.
  4. Overloaded.
  5. Fault.
  6. Replace Battery.
- D. Provide computer UPS with interface communications software for the UPS to automatically perform an orderly shutdown of the computer to prevent loss of data, to monitor operating status of the UPS hardware and power system, and graphically display power system/UPS status.
1. Comply with Section 40 90 10.

### 2.2 DC POWER SUPPLY

- A. Design DC power supply to convert alternating current to direct current and supply the total power requirement of the system plus 25 percent for future expansion.
- B. Provide DC power supply with the following requirements:
1. Input: 120 VAC, 60 Hertz.
  2. Output: DC voltage as required.
  3. Housing: Enclosed housing, DIN mounted.
  4. NEC Class 2.

5. Suitable for use as redundant power supply when connected to redundancy module (for 24 VDC power supplies).
  6. Complies with DeviceNet requirements for DeviceNet power supplies.
  7. Output contact to indicate power supply fault.
  8. Acceptable manufacturers:
    - a. Sola/Hevi-Duty SDN "P" Series.
    - b. Allen Bradley Bulletin 1606-XL.
    - c. Or equal.
- C. Provide Redundant DC power supply module with the following requirements:
1. Nominal voltage: 24VDC.
  2. Housing: Enclosed housing, DIN mounted.
  3. Allows two 24VDC power supplies to be connected to module using isolated inputs.
  4. NEC Class 2.
  5. Output contact to indicate module fault.
  6. Acceptable manufacturers:
    - a. Sola/Hevi-Duty SDN RED Series.
    - b. Allen Bradley Bulletin 1606-XLRED.
    - c. Or equal.

### PART 3 - EXECUTION

#### 3.1 INSTALLATION

- A. Install power supply systems in accordance with manufacturer's recommendations.

END OF SECTION

SECTION 40 97 96  
PROCESS SWITCHES

PART 1 - GENERAL

1.1 SUMMARY

- A. Provide process switches as shown on the Drawings, as specified herein, and as needed for a complete and proper installation.
- B. Related work:
  - 1. Documents affecting work of this Section include, but are not necessarily limited to, General Conditions, Supplementary Conditions, and Division 01 - General Requirements of these Specifications.
- C. References:
  - 1. Reserved.

1.2 SUBMITTALS

- A. Shop Drawing Submittals:
  - 1. Manufacturer's detailed specifications.
- B. Operation and Maintenance Manuals – None Required.
- C. Certificates and Guarantees – None Required.
- D. Lubricants – None Required.
- E. Spare Parts – None Required.

1.3 QUALITY ASSURANCE – Reserved.

1.4 DELIVERY, STORAGE, AND HANDLING

- A. Comply with pertinent provisions of Section 01 66 11.

PART 2 - PRODUCTS

2.1 PROCESS TEMPERATURE SWITCHES

- A. Provide temperature switches for building temperature alarms with the following requirements:
  - 1. Rated for industrial use.
  - 2. Liquid filled sensing element with exposed portion plated and plastic coated.

3. Switch contact:
  - a. SPDT.
  - b. Rated for 5A @ 120VAC.
4. Temperature range: 30 to 110 deg F.
5. Minimum NEMA 12 enclosure.
6. Acceptable manufacturer:
  - a. Johnson Controls, A19 series.
  - b. Or equal.

## 2.2 MAGNETIC DOOR SWITCHES

- A. Provide Magnetic Door Switches with following requirements:
  1. Contact and magnet in anodized aluminum housing.
  2. Contact:
    - a. Hermetically sealed reed switch.
    - b. SPDT, rated for 30V AC/DC, 0.25 A.
  3. Three foot stainless steel armored cable.
  4. Gap distance up to 1½ inches.
  5. Acceptable manufacturers:
    - a. GE/Sentrol 2500 Series.
    - b. Or equal.

## 2.3 FLOOD FLOAT SWITCHES

- A. Provide flood float switches consisting of float, float switch, mounting arm and bracket along with fiberglass NEMA 4X junction box to automatically detect a flood with liquid rise of 3/8-inch. The flood float switch shall require no adjustments or calibration.
- B. Capable of operation on 24 volts.
- C. Acceptable manufacturers:
  1. Anchor Scientific, Model 101FX.
  2. Or equal.

## 2.4 ELECTRONIC FLOW SWITCHES

- A. Provide electronic flow switch with the following features:
  1. No moving parts.
  2. Easy field calibration.
  3. 316L stainless steel sensor.
  4. 1.8-inch probe length.
  5. Nema 4X enclosure.
  6. 1-inch MNPT threaded process connection.
  7. 1-inch FNPT Electrical connection.
  8. 24VDC/VAC operation.
- B. Acceptable manufacturers:
  1. Ameritrol, Series FX.

2. Or equal.

2.5 INSTRUMENT PIPING AND TAPS

- A. Comply with Section 22 19 13.
- B. Provide properly sized snubbers, shut-off valves, and fittings for pressure switches.

PART 3 - EXECUTION

3.1 INSTALLATION

- A. Install process switches in accordance with manufacturer's recommendations.

3.2 CALIBRATION

- A. Calibrate and program equipment to meet system requirements.

3.3 START-UP AND TESTING

- A. Comply with the manufacturer's recommended testing procedures.

END SECTION

**SECTION E: BIDDERS ACKNOWLEDGEMENT**

**BLACKHAWK WATER TOWER  
CONTRACT NO. 7821**

Bidder must state a Unit Price and Total Bid for each item. The Total Bid for each item must be the product of quantity, by Unit Price. The Grand Total must be the sum of the Total Bids for the various items. In case of multiplication errors or addition errors, the Grand Total with corrected multiplication and/or addition shall determine the Grand Total bid for each contract. The Unit Price and Total Bid must be entered numerically in the spaces provided. All words and numbers shall be written in ink.

1. The undersigned having familiarized himself/herself with the Contract documents, including Advertisement for Bids, Instructions to Bidders, Form of Proposal, City of Madison Standard Specifications for Public Works Construction - 2016 Edition thereto, Form of Agreement, Form of Bond, and Addenda issued and attached to the plans and specifications on file in the office of the City Engineer, hereby proposes to provide and furnish all the labor, materials, tools, and expendable equipment necessary to perform and complete in a workmanlike manner the specified construction on this project for the City of Madison; all in accordance with the plans and specifications as prepared by the City Engineer, including Addenda to the Contract Nos. \_\_\_\_\_ through \_\_\_\_\_ issued thereto, at the prices for said work as contained in this proposal. (Electronic bids submittals shall acknowledge addendum under Section E and shall not acknowledge here)
2. If awarded the Contract, we will initiate action within seven (7) days after notification or in accordance with the date specified in the contract to begin work and will proceed with diligence to bring the project to full completion within the number of work days allowed in the Contract or by the calendar date stated in the Contract.
3. The undersigned Bidder or Contractor certifies that he/she is not a party to any contract, combination in form of trust or otherwise, or conspiracy in restraint of trade or commerce or any other violation of the anti-trust laws of the State of Wisconsin or of the United States, with respect to this bid or contract or otherwise.
4. I hereby certify that I have met the Bid Bond Requirements as specified in Section 102.5. *(IF BID BOND IS USED, IT SHALL BE SUBMITTED ON THE FORMS PROVIDED BY THE CITY. FAILURE TO DO SO MAY RESULT IN REJECTION OF THE BID).*
5. I hereby certify that all statements herein are made on behalf of \_\_\_\_\_ (name of corporation, partnership, or person submitting bid) a corporation organized and existing under the laws of the State of \_\_\_\_\_ a partnership consisting of \_\_\_\_\_; an individual trading as \_\_\_\_\_; of the City of \_\_\_\_\_ State of \_\_\_\_\_; that I have examined and carefully prepared this Proposal, from the plans and specifications and have checked the same in detail before submitting this Proposal; that I have fully authority to make such statements and submit this Proposal in (its, their) behalf; and that the said statements are true and correct.

\_\_\_\_\_  
SIGNATURE

\_\_\_\_\_  
TITLE, IF ANY

Sworn and subscribed to before me this \_\_\_\_\_ day of \_\_\_\_\_, 20\_\_\_\_\_.

\_\_\_\_\_  
(Notary Public or other officer authorized to administer oaths)  
My Commission Expires \_\_\_\_\_

Bidders shall not add any conditions or qualifying statements to this Proposal.

## SECTION F: BEST VALUE CONTRACTING

### BLACKHAWK WATER TOWER CONTRACT NO. 7821

#### Best Value Contracting

1. The Contractor shall indicate the non-apprenticeable trades used on this contract.  

---

---
  
2. Madison General Ordinance (M.G.O.), 33.07(7), does provide for some exemptions from the active apprentice requirement. Apprenticeable trades are those trades considered apprenticeable by the State of Wisconsin. Please check applicable box if you are seeking an exemption.
  - Contractor has a total skilled workforce of four or less individuals in all apprenticeable trades combined.
  - No available trade training program; The Contractor has been rejected by the only available trade training program, or there is no trade training program within 90 miles.
  - Contractor is not using an apprentice due to having a journey worker on layoff status, provided the journey worker was employed by the contractor in the past six months.
  - First-time Contractor on City of Madison Public Works contract requests a onetime exemption but intends to comply on all future contracts and is taking steps typical of a "good faith" effort.
  - Contractor has been in business less than one year.
  - Contractor doesn't have enough journeyman trade workers to qualify for a trade training program in that respective trade.
  - An exemption is granted in accordance with a time period of a "Documented Depression" as defined by the State of Wisconsin.
  
3. The Contractor shall indicate on the following section which apprenticeable trades are to be used on this contract. Compliance with active apprenticeship, to the extent required by M.G.O. 33.07(7), shall be satisfied by documentation from an applicable trade training body; an apprenticeship contract with the Wisconsin Department of Workforce Development or a similar agency in another state; or the U.S Department of Labor. This documentation is required prior to the Contractor beginning work on the project site.
  - The Contractor has reviewed the list and shall not use any apprenticeable trades on this project.

**LIST APPRENTICABLE TRADES** (check all that apply to your work to be performed on this contract)

- BRICKLAYER
- CARPENTER
- CEMENT MASON / CONCRETE FINISHER
- CEMENT MASON (HEAVY HIGHWAY)
- CONSTRUCTION CRAFT LABORER
- DATA COMMUNICATION INSTALLER
- ELECTRICIAN
- ENVIRONMENTAL SYSTEMS TECHNICIAN / HVAC SERVICE TECH/HVAC INSTALL / SERVICE
- GLAZIER
- HEAVY EQUIPMENT OPERATOR / OPERATING ENGINEER
- INSULATION WORKER (HEAT & FROST)
- IRON WORKER
- IRON WORKER (ASSEMBLER, METAL BLDGS)
- PAINTER & DECORATOR
- PLASTERER
- PLUMBER
- RESIDENTIAL ELECTRICIAN
- ROOFER & WATER PROOFER
- SHEET METAL WORKER
- SPRINKLER FITTER
- STEAMFITTER
- STEAMFITTER (REFRIGERATION)
- STEAMFITTER (SERVICE)
- TAPER & FINISHER
- TELECOMMUNICATIONS (VOICE, DATA & VIDEO) INSTALLER-TECHNICIAN
- TILE SETTER



## **SECTION G: BID BOND**

KNOW ALL MEN BY THESE PRESENT, THAT Principal and Surety, as identified below, are held and firmly bound unto the City of Madison, (hereinafter referred to as the "Obligee"), in the sum of five per cent (5%) of the amount of the total bid or bids of the Principal herein accepted by the Obligee, for the payment of which the Principal and the Surety bind themselves, their heirs, executors, administrators, successors and assigns, jointly and severally, firmly by these presents.

The conditions of this obligation are such that, whereas the Principal has submitted, to the City of Madison a certain bid, including the related alternate, and substitute bids attached hereto and hereby made a part hereof, to enter into a contract in writing for the construction of:

### **BLACKHAWK WATER TOWER CONTRACT NO. 7821**

1. If said bid is rejected by the Obligee, then this obligation shall be void.
2. If said bid is accepted by the Obligee and the Principal shall execute and deliver a contract in the form specified by the Obligee (properly completed in accordance with said bid) and shall furnish a bond for his/her faithful performance of said contract, and for the payment of all persons performing labor or furnishing materials in connection therewith, and shall in all other respects perform the agreement created by the acceptance of said bid, then this obligation shall be void.

If said bid is accepted by the Obligee and the Principal shall fail to execute and deliver the contract and the performance and payment bond noted in 2. above executed by this Surety, or other Surety approved by the City of Madison, all within the time specified or any extension thereof, the Principal and Surety agree jointly and severally to forfeit to the Obligee as liquidated damages the sum mentioned above, it being understood that the liability of the Surety for any and all claims hereunder shall in no event exceed the sum of this obligation as stated, and it is further understood that the Principal and Surety reserve the right to recover from the Obligee that portion of the forfeited sum which exceed the actual liquidated damages incurred by the Obligee.

The Surety, for value received, hereby stipulates and agrees that the obligations of said Surety and its bond shall be in no way impaired or affected by an extension of the time within which the Obligee may accept such bid, and said Surety does hereby waive notice of any such extension.

IN WITNESS WHEREOF, the Principal and the Surety have hereunto set their hands and seals, and such of them as are corporations have caused their corporate seals to be hereto affixed and these presents to be signed by their proper officers, on the day and year set forth below.

Seal      PRINCIPAL

\_\_\_\_\_  
Name of Principal

\_\_\_\_\_  
By

\_\_\_\_\_  
Date

\_\_\_\_\_  
Name and Title

Seal      SURETY

\_\_\_\_\_  
Name of Surety

\_\_\_\_\_  
By

\_\_\_\_\_  
Date

\_\_\_\_\_  
Name and Title

This certifies that I have been duly licensed as an agent for the above company in Wisconsin under National Provider No. \_\_\_\_\_ for the year \_\_\_\_\_, and appointed as attorney in fact with authority to execute this bid bond and the payment and performance bond referred to above, which power of attorney has not been revoked.

\_\_\_\_\_  
Date

\_\_\_\_\_  
Agent Signature

\_\_\_\_\_  
Address

\_\_\_\_\_  
City, State and Zip Code

\_\_\_\_\_  
Telephone Number

**NOTE TO SURETY & PRINCIPAL**

The bid submitted which this bond guarantees shall be rejected if the following instrument is not attached to this bond:

Power of Attorney showing that the agent of Surety is currently authorized to execute bonds on behalf of the Surety, and in the amounts referenced above.

## Certificate of Biennial Bid Bond

TIME PERIOD - VALID (FROM/TO)
NAME OF SURETY
NAME OF CONTRACTOR
CERTIFICATE HOLDER <p style="text-align: center;">City of Madison, Wisconsin</p>

This is to certify that a biennial bid bond issued by the above-named Surety is currently on file with the City of Madison.

This certificate is issued as a matter of information and conveys no rights upon the certificate holder and does not amend, extend or alter the coverage of the biennial bid bond.

Cancellation: Should the above policy be cancelled before the expiration date, the issuing Surety will give thirty (30) days written notice to the certificate holder indicated above.

\_\_\_\_\_  
Signature of Authorized Contractor Representative

\_\_\_\_\_  
Date

## SECTION H: AGREEMENT

THIS AGREEMENT made this \_\_\_\_\_ day of \_\_\_\_\_ in the year Two Thousand and Seventeen between \_\_\_\_\_ hereinafter called the Contractor, and the City of Madison, Wisconsin, hereinafter called the City.

WHEREAS, the Common Council of the said City of Madison under the provisions of a resolution adopted \_\_\_\_\_, and by virtue of authority vested in the said Council, has awarded to the Contractor the work of performing certain construction.

NOW, THEREFORE, the Contractor and the City, for the consideration hereinafter named, agree as follows:

1. **Scope of Work.** The Contractor shall, perform the construction, execution and completion of the following listed complete work or improvement in full compliance with the Plans, Specifications, Standard Specifications, Supplemental Specifications, Special Provisions and contract; perform all items of work covered or stipulated in the proposal; perform all altered or extra work; and shall furnish, unless otherwise provided in the contract, all materials, implements, machinery, equipment, tools, supplies, transportation, and labor necessary to the prosecution and completion of the work or improvements:

### BLACKHAWK WATER TOWER CONTRACT NO. 7821

2. **Completion Date/Contract Time.** Construction work must begin within seven (7) calendar days after the date appearing on mailed written notice to do so shall have been sent to the Contractor and shall be carried on at a rate so as to secure full completion SEE SPECIAL PROVISIONS, the rate of progress and the time of completion being essential conditions of this Agreement.
3. **Contract Price.** The City shall pay to the Contractor at the times, in the manner and on the conditions set forth in said specifications, the sum of \_\_\_\_\_ (\$\_\_\_\_\_) Dollars being the amount bid by such Contractor and which was awarded to him/her as provided by law.
4. **Affirmative Action.** In the performance of the services under this Agreement the Contractor agrees not to discriminate against any employee or applicant because of race, religion, marital status, age, color, sex, disability, national origin or ancestry, income level or source of income, arrest record or conviction record, less than honorable discharge, physical appearance, sexual orientation, gender identity, political beliefs, or student status. The Contractor further agrees not to discriminate against any subcontractor or person who offers to subcontract on this contract because of race, religion, color, age, disability, sex, sexual orientation, gender identity or national origin.

The Contractor agrees that within thirty (30) days after the effective date of this agreement, the Contractor will provide to the City Affirmative Action Division certain workforce utilization statistics, using a form to be furnished by the City.

If the contract is still in effect, or if the City enters into a new agreement with the Contractor, within one year after the date on which the form was required to be provided, the Contractor will provide updated workforce information using a second form, also to be furnished by the City. The second form will be submitted to the City Affirmative Action Division no later than one year after the date on which the first form was required to be provided.

The Contractor further agrees that, for at least twelve (12) months after the effective date of this contract, it will notify the City Affirmative Action Division of each of its job openings at facilities in Dane County for which applicants not already employees of the Contractor are to be considered. The notice will include a job description, classification, qualifications and application procedures

and deadlines. The Contractor agrees to interview and consider candidates referred by the Affirmative Action Division if the candidate meets the minimum qualification standards established by the Contractor, and if the referral is timely. A referral is timely if it is received by the Contractor on or before the date started in the notice.

Articles of Agreement  
Article I

The Contractor shall take affirmative action in accordance with the provisions of this contract to insure that applicants are employed, and that employees are treated during employment without regard to race, religion, color, age, marital status, disability, sex, sexual orientation, gender identity or national origin and that the employer shall provide harassment free work environment for the realization of the potential of each employee. Such action shall include, but not be limited to, the following: employment, upgrading, demotion or transfer, recruitment or recruitment advertising, layoff or termination, rates of pay or other forms of compensation and selection for training including apprenticeship insofar as it is within the control of the Contractor. The Contractor agrees to post in conspicuous places available to employees and applicants notices to be provided by the City setting out the provisions of the nondiscrimination clauses in this contract.

Article II

The Contractor shall in all solicitations or advertisements for employees placed by or on behalf of the Contractors state that all qualified or qualifiable applicants will be employed without regard to race, religion, color, age, marital status, disability, sex, sexual orientation, gender identity or national origin.

Article III

The Contractor shall send to each labor union or representative of workers with which it has a collective bargaining agreement or other contract or understanding a notice to be provided by the City advising the labor union or worker's representative of the Contractor's equal employment opportunity and affirmative action commitments. Such notices shall be posted in conspicuous places available to employees and applicants for employment.

Article V

The Contractor agrees that it will comply with all provisions of the Affirmative Action Ordinance of the City of Madison, including the contract compliance requirements. The Contractor agrees to submit the model affirmative action plan for public works contractors in a form approved by the Affirmative Action Division Manager.

Article VI

The Contractor will maintain records as required by Section 39.02(9)(f) of the Madison General Ordinances and will provide the City Affirmative Action Division with access to such records and to persons who have relevant and necessary information, as provided in Section 39.02(9)(f). The City agrees to keep all such records confidential, except to the extent that public inspection is required by law.

Article VII

In the event of the Contractor's or subcontractor's failure to comply with the Equal Employment Opportunity and Affirmative Action Provisions of this contract or Section 39.03 and 39.02 of the Madison General Ordinances, it is agreed that the City at its option may do any or all of the following:

1. Cancel, terminate or suspend this Contract in whole or in part.

2. Declare the Contractor ineligible for further City contracts until the Affirmative Action requirements are met.
3. Recover on behalf of the City from the prime Contractor 0.5 percent of the contract award price for each week that such party fails or refuses to comply, in the nature of liquidated damages, but not to exceed a total of five percent (5%) of the contract price, or five thousand dollars (\$5,000), whichever is less. Under public works contracts, if a subcontractor is in noncompliance, the City may recover liquidated damages from the prime Contractor in the manner described above. The preceding sentence shall not be construed to prohibit a prime Contractor from recovering the amount of such damage from the non-complying subcontractor.

#### Article VIII

The Contractor shall include the above provisions of this contract in every subcontract so that such provisions will be binding upon each subcontractor. The Contractor shall take such action with respect to any subcontractor as necessary to enforce such provisions, including sanctions provided for noncompliance.

#### Article IX

The Contractor shall allow the maximum feasible opportunity to small business enterprises to compete for any subcontracts entered into pursuant to this contract. (In federally funded contracts the terms "DBE, MBE and WBE" shall be substituted for the term "small business" in this Article.)

5. Substance Abuse Prevention Program Required. Prior to commencing work on the Contract, the Contractor, and any Subcontractor, shall have in place a written program for the prevention of substance abuse among its employees as required under Wis. Stat. Sec. 103.503.
6. **Contractor Hiring Practices.**

#### **Ban the Box - Arrest and Criminal Background Checks. (Sec. 39.08, MGO)**

This provision applies to all prime contractors on contracts entered into on or after January 1, 2016, and all subcontractors who are required to meet prequalification requirements under MGO 33.07(7)(l), MGO as of the first time they seek or renew pre-qualification status on or after January 1, 2016. The City will monitor compliance of subcontractors through the pre-qualification process.

- a. **Definitions.** For purposes of this section, "Arrest and Conviction Record" includes, but is not limited to, information indicating that a person has been questioned, apprehended, taken into custody or detention, held for investigation, arrested, charged with, indicted or tried for any felony, misdemeanor or other offense pursuant to any law enforcement or military authority.

"Conviction record" includes, but is not limited to, information indicating that a person has been convicted of a felony, misdemeanor or other offense, placed on probation, fined, imprisoned or paroled pursuant to any law enforcement or military authority.

"Background Check" means the process of checking an applicant's arrest and conviction record, through any means.

- b. **Requirements.** For the duration of this Contract, the Contractor shall:

1. Remove from all job application forms any questions, check boxes, or other inquiries regarding an applicant's arrest and conviction record, as defined herein.

2. Refrain from asking an applicant in any manner about their arrest or conviction record until after conditional offer of employment is made to the applicant in question.
3. Refrain from conducting a formal or informal background check or making any other inquiry using any privately or publicly available means of obtaining the arrest or conviction record of an applicant until after a conditional offer of employment is made to the applicant in question.
4. Make information about this ordinance available to applicants and existing employees, and post notices in prominent locations at the workplace with information about the ordinance and complaint procedure using language provided by the City.
5. Comply with all other provisions of Sec. 39.08, MGO.

**c. Exemptions:** This section shall not apply when:

1. Hiring for a position where certain convictions or violations are a bar to employment in that position under applicable law, or
2. Hiring a position for which information about criminal or arrest record, or a background check is required by law to be performed at a time or in a manner that would otherwise be prohibited by this ordinance, including a licensed trade or profession where the licensing authority explicitly authorizes or requires the inquiry in question.

To be exempt, Contractor has the burden of demonstrating that there is an applicable law or regulation that requires the hiring practice in question, if so, the contractor is exempt from all of the requirements of this ordinance for the position(s) in question.

**BLACKHAWK WATER TOWER  
CONTRACT NO. 7821**

IN WITNESS WHEREOF, the Contractor has hereunto set his/her hand and seal and the City has caused these presents to be sealed with its corporate seal and to be subscribed by its Mayor and City Clerk the day and year first above written.

Countersigned:

	_____
	Company Name
Witness	Date
Witness	Date

CITY OF MADISON, WISCONSIN

Provisions have been made to pay the liability that will accrue under this contract.

Approved as to form:

Finance Director	City Attorney
Signed this _____ day of _____, 20_____	
Witness	Mayor
Witness	City Clerk



**SECTION I: PAYMENT AND PERFORMANCE BOND**

KNOW ALL MEN BY THESE PRESENTS, that we \_\_\_\_\_  
as principal, \_\_\_\_\_ and

Company of \_\_\_\_\_ as surety, are held and firmly bound unto the City of  
Madison, Wisconsin, in the sum of \_\_\_\_\_ (\$\_\_\_\_\_) Dollars, lawful money of the  
United States, for the payment of which sum to the City of Madison, we hereby bind ourselves and our  
respective executors and administrators firmly by these presents.

The condition of this Bond is such that if the above bounden shall on his/her part fully and faithfully  
perform all of the terms of the Contract entered into between him/herself and the City of Madison for the  
construction of:

**BLACKHAWK WATER TOWER  
CONTRACT NO. 7821**

in Madison, Wisconsin, and shall pay all claims for labor performed and material furnished in the  
prosecution of said work, and save the City harmless from all claims for damages because of negligence  
in the prosecution of said work, and shall save harmless the said City from all claims for compensation  
(under Chapter 102, Wisconsin Statutes) of employees and employees of subcontractor, then this Bond is  
to be void, otherwise of full force, virtue and effect.

Signed and sealed this \_\_\_\_\_ day of \_\_\_\_\_

Countersigned:

\_\_\_\_\_  
Company Name (Principal)

\_\_\_\_\_  
Witness

\_\_\_\_\_  
President Seal

\_\_\_\_\_  
Secretary

Approved as to form:

\_\_\_\_\_  
Surety Seal

Salary Employee       Commission

\_\_\_\_\_  
City Attorney

By \_\_\_\_\_  
Attorney-in-Fact

This certifies that I have been duly licensed as an agent for the above company in Wisconsin under  
National Producer Number \_\_\_\_\_ for the year \_\_\_\_\_, and appointed as attorney-in-fact  
with authority to execute this payment and performance bond which power of attorney has not been  
revoked.

\_\_\_\_\_  
Date

\_\_\_\_\_  
Agent Signature