



Department of Public Works  
**Engineering Division**  
Robert F. Phillips, P.E., City Engineer

City-County Building, Room 115  
210 Martin Luther King, Jr. Boulevard  
Madison, Wisconsin 53703  
Phone: (608) 266-4751  
Fax: (608) 264-9275  
[engineering@cityofmadison.com](mailto:engineering@cityofmadison.com)  
[www.cityofmadison.com/engineering](http://www.cityofmadison.com/engineering)

**Assistant City Engineer**  
Michael R. Dailey, P.E.

**Principal Engineer 2**  
Gregory T. Fries, P.E.

**Principal Engineer 1**  
Christina M. Bachmann, P.E.  
Eric L. Dundee, P.E.  
John S. Fahrney, P.E.  
Christopher J. Petykowski, P.E.

**Facilities & Sustainability**  
Jeanne E. Hoffman, Manager

**Operations Manager**  
Kathleen M. Cryan

**Mapping Section Manager**  
Eric T. Pederson, P.S.

**Financial Manager**  
Steven B. Danner-Rivers

April 5, 2017

### NOTICE OF ADDENDUM ADDENDUM 3

CONTRACT NO. 7928

Revise and amend the contract document(s) for the above project as stated in this addendum, otherwise, the original document shall remain in effect.

#### QUESTIONS:

Q: *Is hydrodemolition appropriate for this contract?*

A: No, there is not enough concrete demolition to warrant this method; among other concerns including noise and water cleanup.

Q: *What is the welded stud spacing on the angle on detail 1/D3 at the CSN haunch repair?*

A: Please see the supplemental detail below for specific information regarding the fabrication of the support angle segments – used to fulfil the total length necessary.

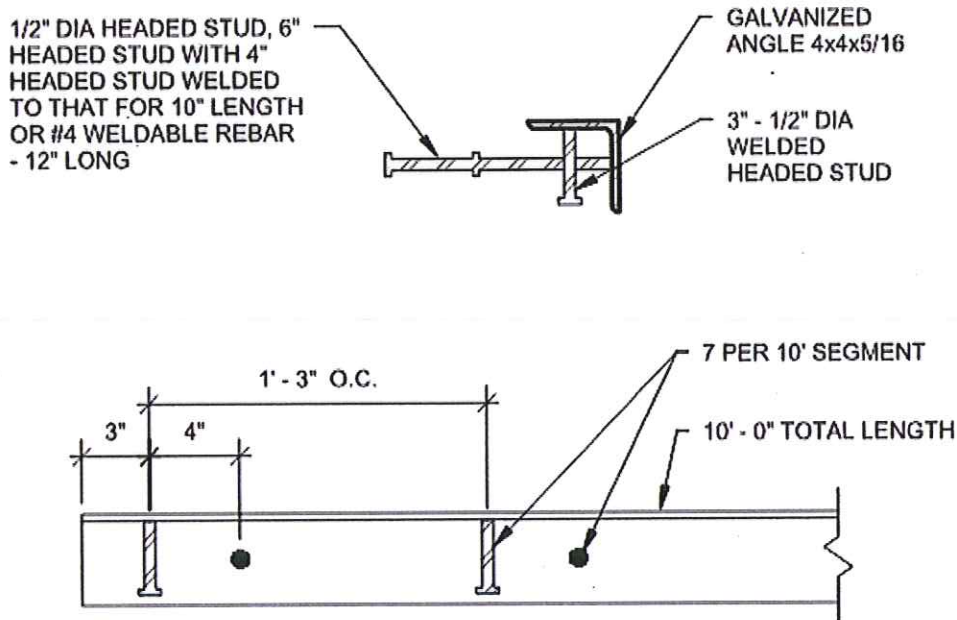

April 5, 2017  
Page 2

Please acknowledge this addendum on page E1 of the contract documents and/or in Section E: Bidder's Acknowledgement on Bid Express.

Electronic version of these documents can be found on the Bid Express web site at:

<http://www.bidexpress.com>

If you are unable to download plan revisions associated with the addendum, please contact the Engineering office at 608-266-4751 receive the material by another route.

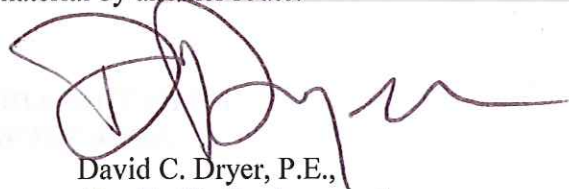
A handwritten signature in dark ink, appearing to read 'David C. Dryer', is written over the typed name and title.

David C. Dryer, P.E.,  
City Traffic Engineer and  
Parking Utility Manager