



Madison, Wisconsin

# CITY OF MADISON

CITY ENGINEERING DIVISION

DEPARTMENT OF PUBLIC WORKS

## PLAN OF PROPOSED IMPROVEMENT

### FELLAND ROAD & TRANQUILITY TRAIL ROUNDABOUT

### ASSESSMENT DISTRICT - 2021

CITY PROJECT NO. 13270

CONTRACT NO. 8564

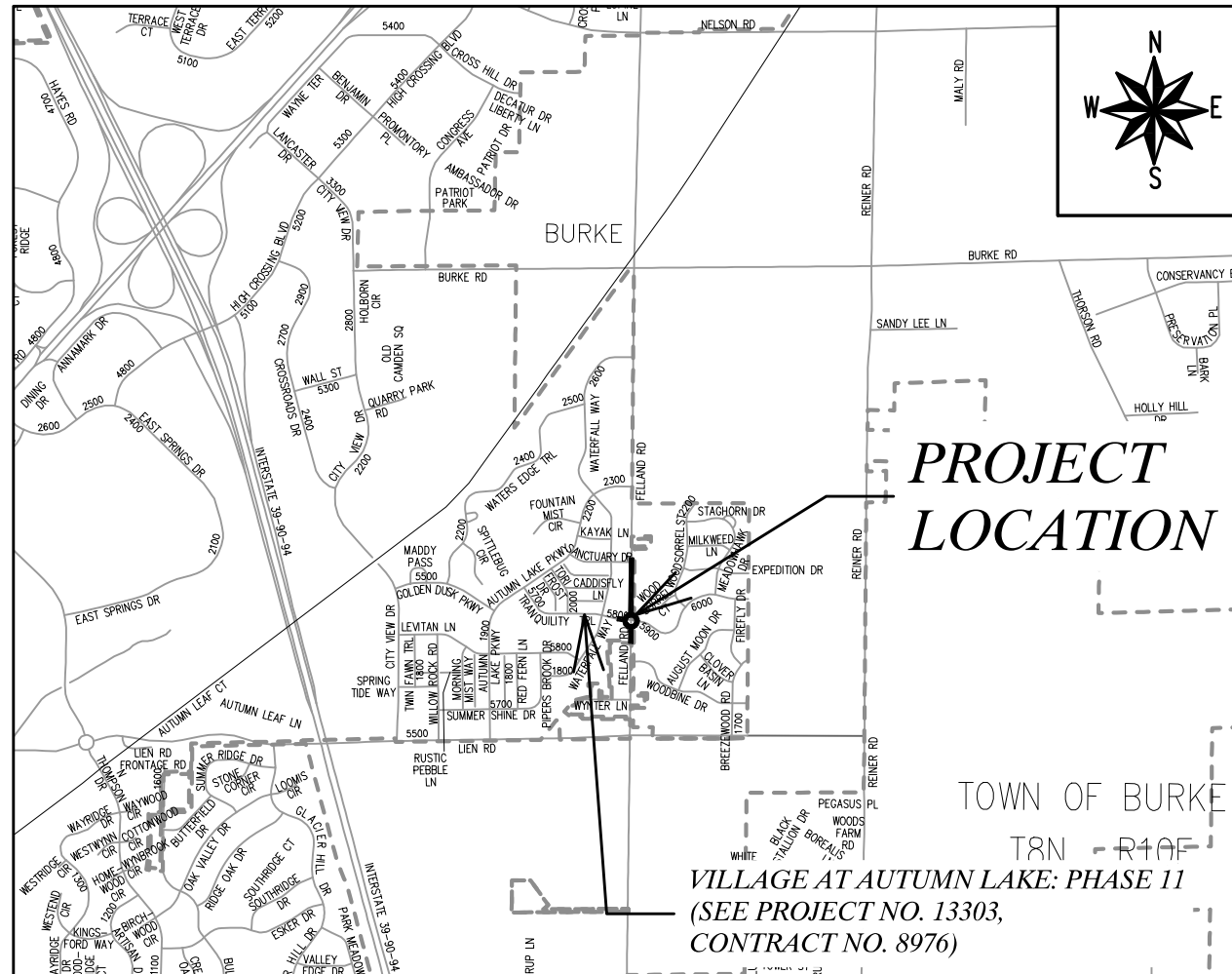

**PROJECT LOCATION**

VILLAGE AT AUTUMN LAKE: PHASE 11  
(SEE PROJECT NO. 13303,  
CONTRACT NO. 8976)

**EARTHWORK SUMMARY:**

EXCAVATION CUT (MEASURED PLAN QUANTITY).....	7330 CY
ESTIMATED UNDISTRIBUTED UNDERCUT.....	910 CY
TOTAL UNCLASSIFIED EXCAVATION CUT.....	8240 CY

**INDEX OF SHEETS**

SHEET NO. 1	TITLE SHEET
SHEET NO. D1-D3	TYPICAL SECTIONS
SHEET NO. D4	ROUNDBOUT DETAIL
SHEET NO. EC1-EC4	EROSION CONTROL PLANS
SHEET NO. P1-P4	STREET PLAN & PROFILES
SHEET NO. U1-U4	UTILITY PLAN & PROFILES
SHEET NO. U5	SANITARY SEWER SCHEDULE
SHEET NO. U6-U7	STORM SEWER SCHEDULE
SHEET NO. W1-W3	WATER PLANS
SHEET NO. E1-E5	ELECTRICAL PLANS
SHEET NO. M1-M2	PAVEMENT MARKING PLANS
SHEET NO. X1-X11	FELLAND RD CROSS SECTIONS
SHEET NO. X12-X13	OL 46 PATH CROSS SECTIONS
SHEET NO. C1-C2	CHANNEL CROSS SECTIONS
SHEET NO. MN-1	MAINTENANCE PLAN

CONVENTIONAL SIGNS	
FIELD VERIFY ALL UTILITY LOCATIONS	
GAS	— G —
STORM SEWER	— ST —
SANITARY SEWER	— SN —
WATER	— W —
BURIED ELECTRIC	— E —
OVERHEAD ELECTRIC	— OH —
POWER POLE	
ADA COMPLIANT RAMP W/ DETECTABLE WARNING FIELD	
COMBUSTIBLE FLUIDS	

**NOTES:**

ALL GUTTERS SHALL DRAIN WITH A MINIMUM GRADE OF 0.50% TOWARD STORM SEWER INLETS.

SIDEWALK RAMPS SHALL HAVE A MAXIMUM SLOPE OF 1" PER 12". SIDEWALK AND CURB RAMPS SHALL BE CONSTRUCTED WITH A SIDE SLOPE OF 2.00%. SIDEWALK SHALL HAVE A MINIMUM LONGITUDINAL SLOPE OF 0.50% AND A MAXIMUM LONGITUDINAL SLOPE OF 5.00% EXCEPT WHERE STREET GRADES EXCEED 5.00%.

PUBLIC IMPROVEMENT PROJECT APPROVED

MAY 18, 2021

BY THE COMMON COUNCIL OF MADISON, WISCONSIN

PUBLIC IMPROVEMENT DESIGN APPROVED BY:

*Christy Bachmann for* May 14, 2021  
Christy Bachmann for (May 14, 2021 15:54 CDT)

City Engineer Date

ELECTRICAL DESIGNED BY:

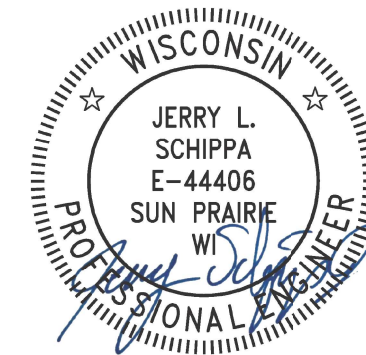

May 14, 2021

STREET GRADES DESIGNED BY:

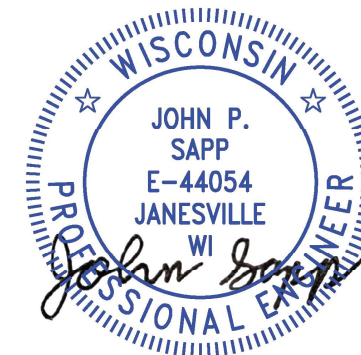

May 14, 2021

PAVEMENT MARKINGS DESIGNED BY:

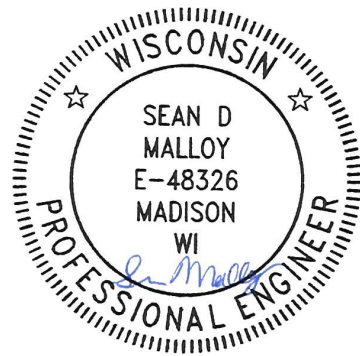

May 17, 2021

STORM & SANITARY SEWER DESIGNED BY:



May 14, 2021

STREET GEOMETRICS DESIGNED BY:



May 17, 2021

WATER MAIN DESIGNED BY:



May 14, 2021

PLOT SCALE: 1"=1'-0" XREF

PLOT NAME: ---

REV. DATE: 5/11/2021 4:41 PM

ORIGINATOR: CITY\_OF\_MADISON

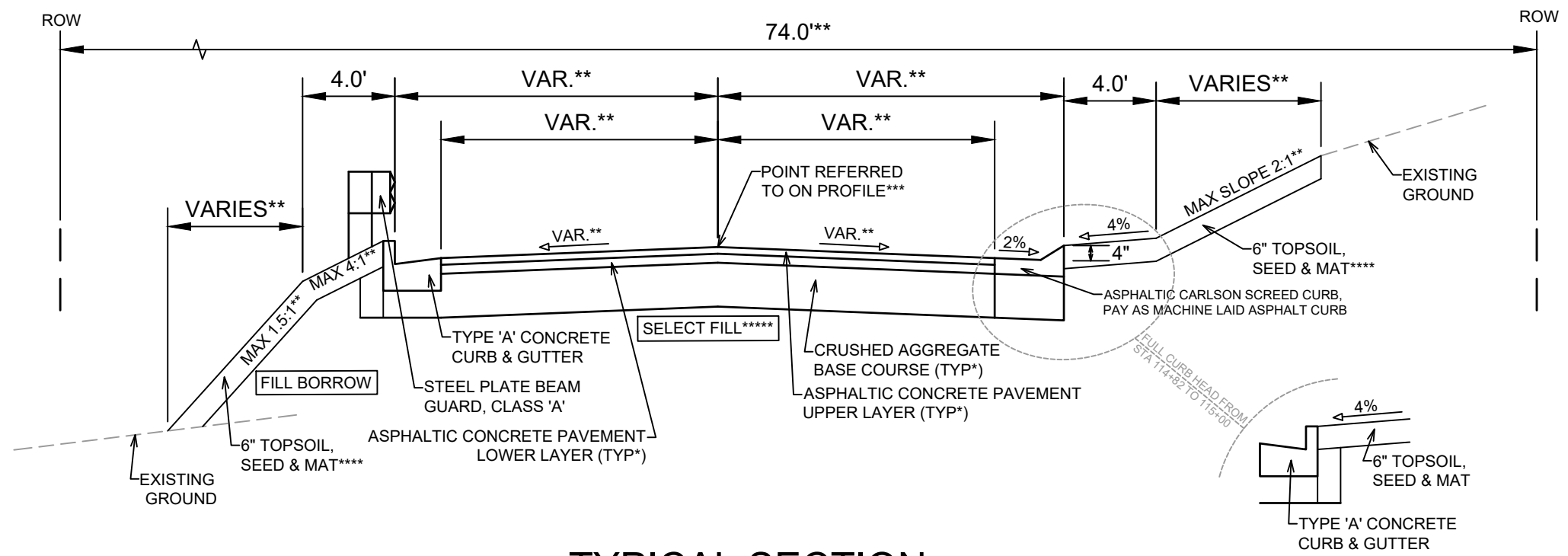

**TYPICAL SECTION**  
 FELLAND ROAD  
 (STA 114+00 TO STA 115+00)

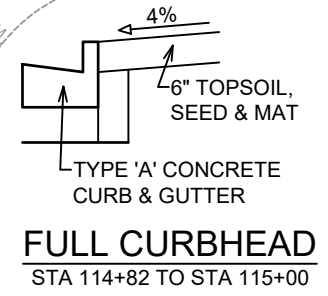

**FULL CURBHEAD**  
 STA 114+82 TO STA 115+00

**NOTES:**

- \*FELLAND ROAD SHALL BE CONSTRUCTED AS TYPE 'B' PAVEMENT PER CITY OF MADISON MINIMUM PAVEMENT DESIGN†
- \*\*SEE PLAN AND CROSS-SECTIONS FOR DETAILS AND DIMENSIONS
- \*\*\*OFFSET CENTERLINE TRANSITION ON FELLAND ROAD FROM STA 122+14 TO STA 123+68. SEE PLAN AND CROSS-SECTIONS.
- \*\*\*\*SIDE-SLOPES STEEPER THAN 3:1 SHOULD USE EROSION MATTING, CLASS I, TYPE B - ORGANIC (PER SPECS).
- \*\*\*\*\*SELECT FILL UNDER ROADWAY AND PATH SUBGRADE, DEPTH VARIES; 2" SELECT FILL UNDER SIDEWALK

CITY OF MADISON MINIMUM PAVEMENT DESIGN †

TYPE	CRUSHED AGGREGATE BASE COURSE		ASPHALTIC CONCRETE PAVEMENT			
	LOWER LAYER GRADATION 1	UPPER LAYER GRADATION 2	LOWER LAYER		UPPER LAYER	
			TYPE	THICKNESS	TYPE	THICKNESS
A	6"	6"	4 LT 58-28 S	1.75"	4 LT 58-28 S	1.75"
B	6"	6"	3 LT 58-28 S	2.50"	4 LT 58-28 S	2.00"
C	6"	6"	3 MT 58-28 S/H	3.50"	4 MT 58-28 S/H	2.00"

MARK	REVISION	DATE	BY
13270	5/13/2021	3:35 PM	Scale: #####
13270			D-1

13270  
 MADISON, WI  
 8564  
 CONTRACT NO:  
 TYPICAL SECTIONS  
 FELLAND ROAD & TRANQUILITY TRAIL ROUNDABOUT  
 M:\DESIGN\Projects\13303\CAD\Streets\13270EN-FellandRAB-Details.dwg

13270  
 D-1

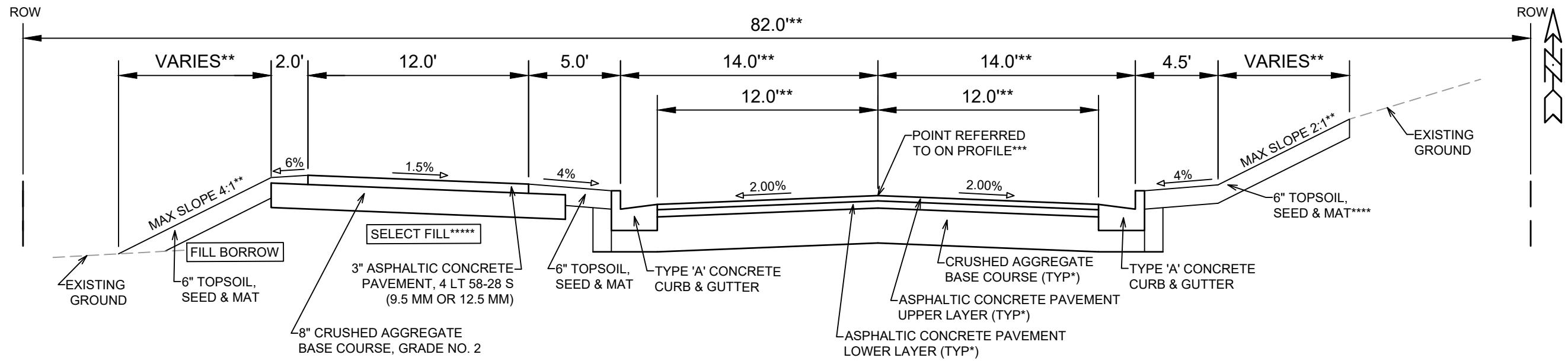

**TYPICAL SECTION**  
**FELLAND ROAD**  
 (STA 118+15 TO STA 122+14)

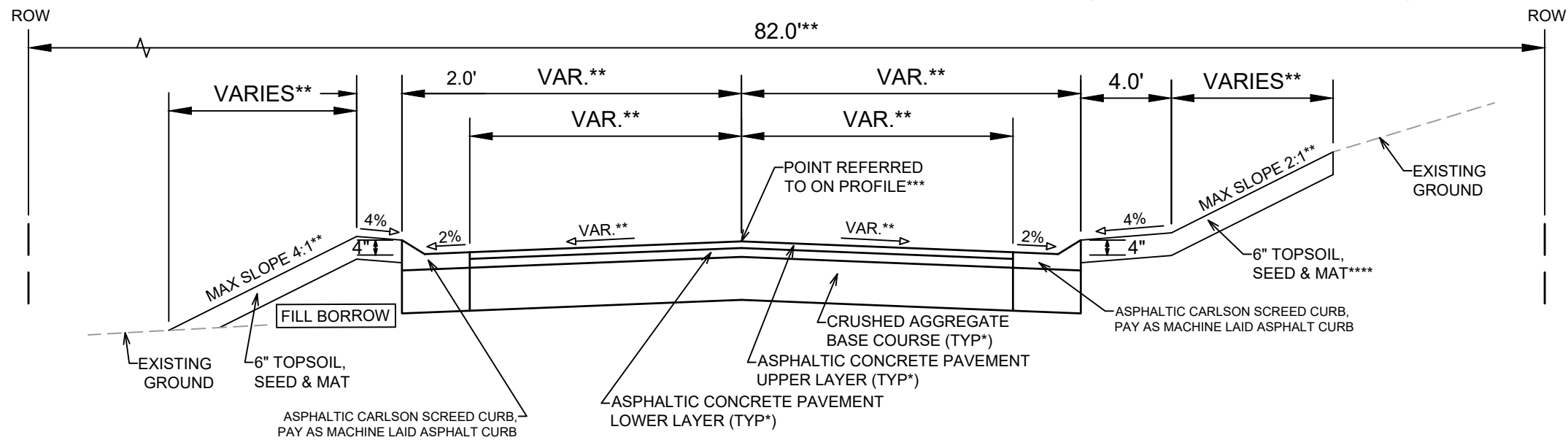

**TYPICAL SECTION**  
**FELLAND ROAD**  
 (STA 122+14 TO STA 123+68)

**NOTES:**

\*FELLAND ROAD SHALL BE CONSTRUCTED AS TYPE 'B' PAVEMENT PER CITY OF MADISON MINIMUM PAVEMENT DESIGN†

\*\*SEE PLAN AND CROSS-SECTIONS FOR DETAILS AND DIMENSIONS

\*\*\*OFFSET CENTERLINE TRANSITION ON FELLAND ROAD FROM STA 122+14 TO STA 123+68. SEE PLAN AND CROSS-SECTIONS.

\*\*\*\*SIDE-SLOPES STEEPER THAN 3:1 SHOULD USE EROSION MATTING, CLASS I, TYPE B - ORGANIC (PER SPECS).

\*\*\*\*\*SELECT FILL UNDER ROADWAY AND PATH SUBGRADE, DEPTH VARIES; 2" SELECT FILL UNDER SIDEWALK

CITY OF MADISON MINIMUM PAVEMENT DESIGN †

TYPE	CRUSHED AGGREGATE BASE COURSE		ASPHALTIC CONCRETE PAVEMENT			
	LOWER LAYER GRADATION 1	UPPER LAYER GRADATION 2	LOWER LAYER		UPPER LAYER	
			TYPE	THICKNESS	TYPE	THICKNESS
A	6"	6"	4 LT 58-28 S	1.75"	4 LT 58-28 S	1.75"
B	6"	6"	3 LT 58-28 S	2.50"	4 LT 58-28 S	2.00"
C	6"	6"	3 MT 58-28 S/H	3.50"	4 MT 58-28 S/H	2.00"

DATE	BY
REVISION	SCALE: #####
DESIGNED BY: AJC	DATE: 5/13/2021 3:35 PM
MARK	13270
PROJECT	D-2

13270  
 MADISON, WI  
 8564  
 CONTRACT NO:

TYPICAL SECTIONS  
 FELLAND ROAD & TRANQUILITY TRAIL ROUNDABOUT  
 M:\DESIGN\Projects\13303\CAD\Streets\13270EN-FellandRAB-Details.dwg



13270  
 D-2

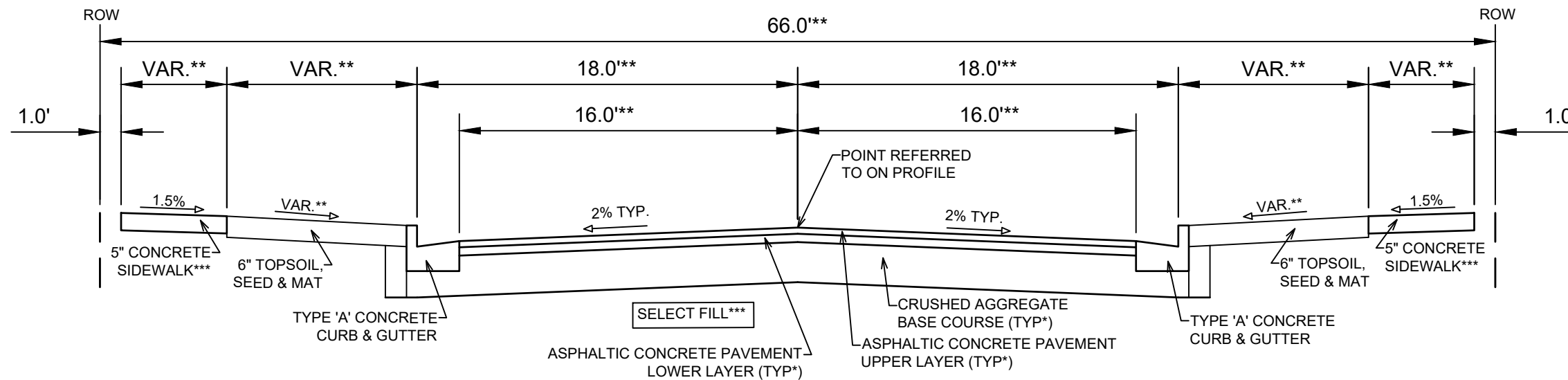

**TYPICAL SECTION**  
 TRANQUILITY TRAIL  
 (STA 22+00 TO STA 22+46)

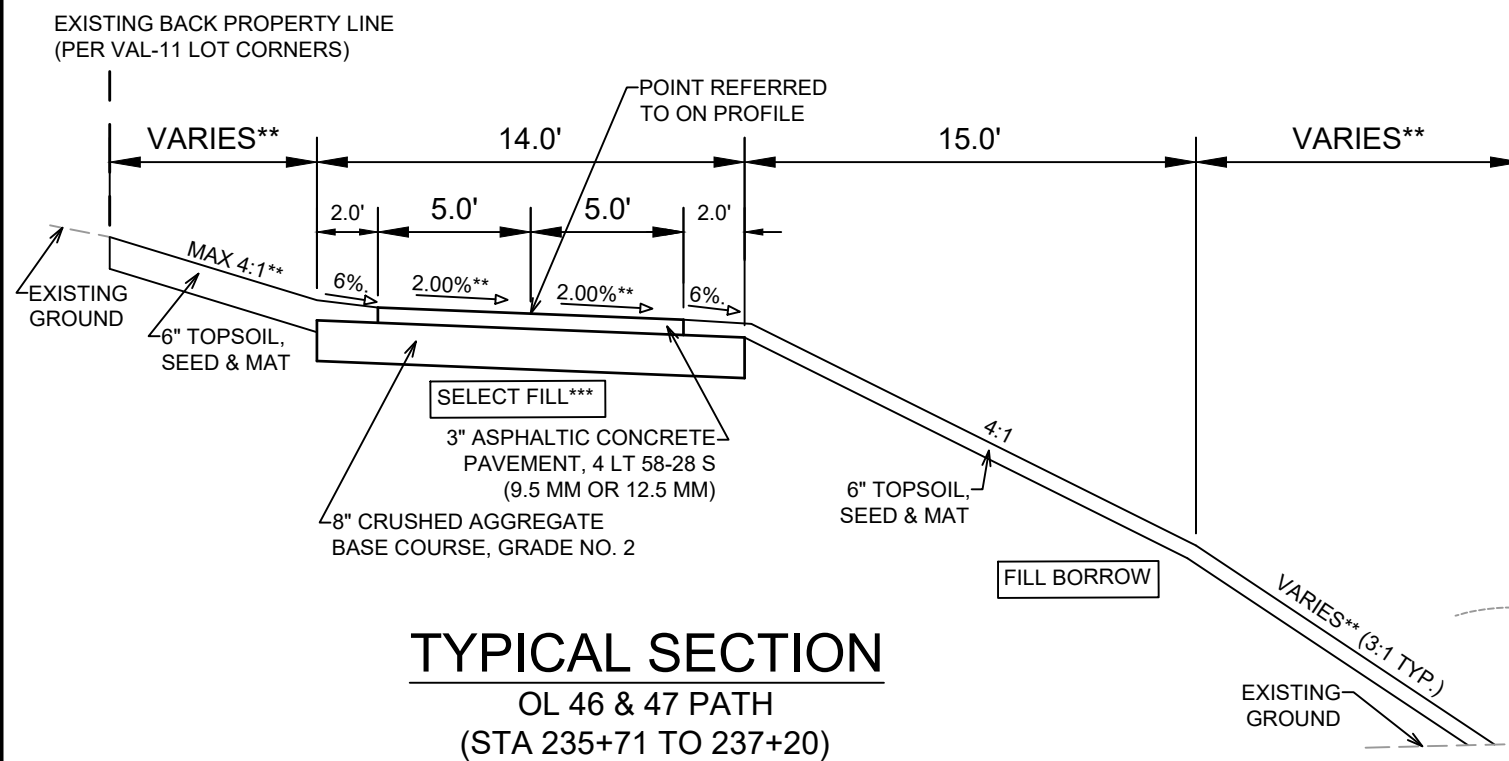

**TYPICAL SECTION**  
 OL 46 & 47 PATH  
 (STA 235+71 TO 237+20)

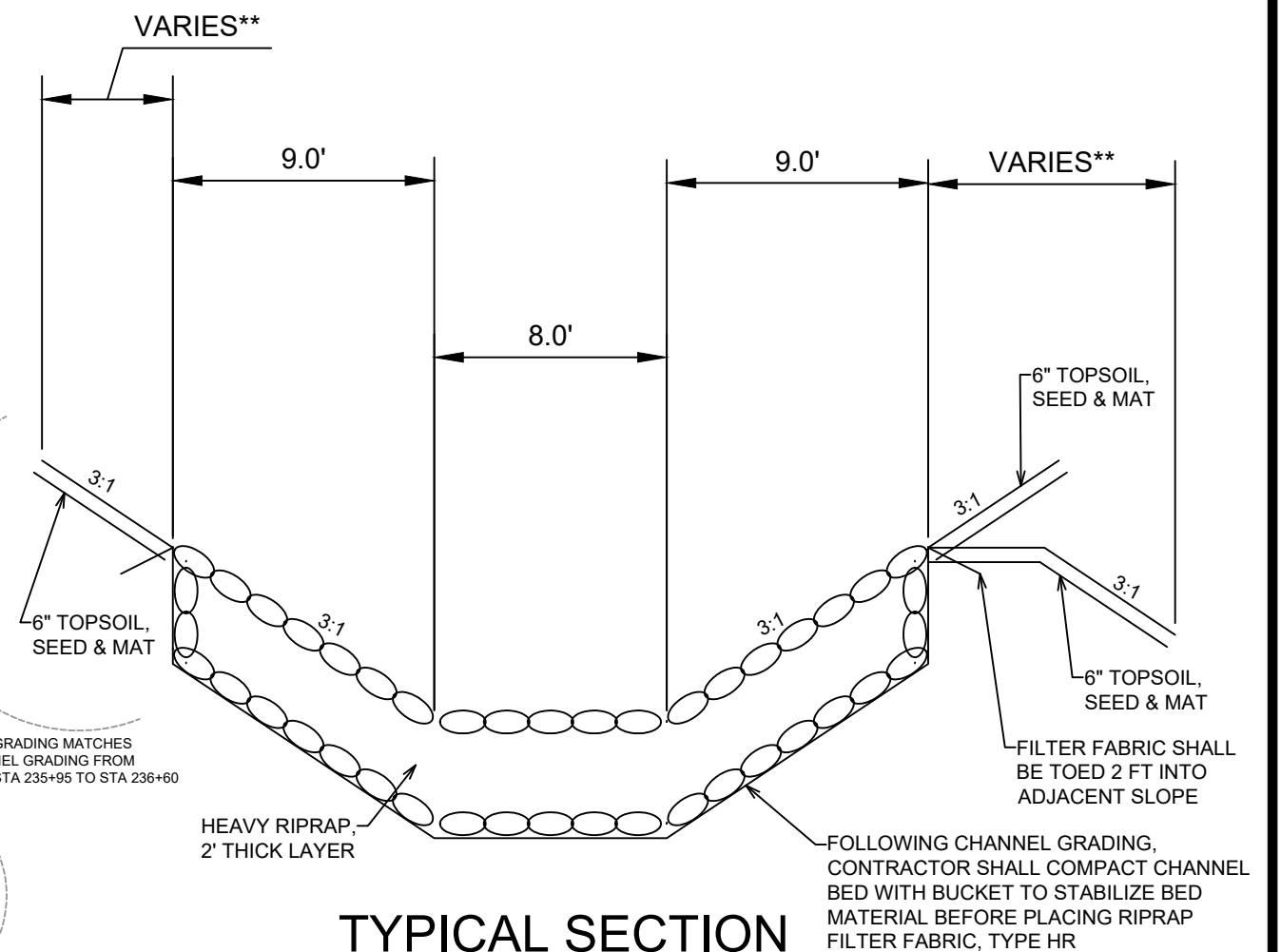

**TYPICAL SECTION**  
 FELLAND ROAD CHANNEL  
 (STA 0+50 TO 2+20)

**NOTES:**

\* TRANQUILITY TRAIL SHALL BE CONSTRUCTED AS TYPE 'A' PAVEMENT PER CITY OF MADISON MINIMUM PAVEMENT DESIGN †

\*\* SEE PLAN AND CROSS-SECTION FOR DETAILS AND DIMENSIONS.

\*\*\* SELECT FILL UNDER ROADWAY AND PATH SUBGRADE, DEPTH VARIES; 2" SELECT FILL UNDER SIDEWALK

CITY OF MADISON MINIMUM PAVEMENT DESIGN †

TYPE	CRUSHED AGGREGATE BASE COURSE		ASPHALTIC CONCRETE PAVEMENT			
	LOWER LAYER GRADATION 1	UPPER LAYER GRADATION 2	LOWER LAYER		UPPER LAYER	
			TYPE	THICKNESS	TYPE	THICKNESS
A	6"	6"	4 LT 58-28 S	1.75"	4 LT 58-28 S	1.75"
B	6"	6"	3 LT 58-28 S	2.50"	4 LT 58-28 S	2.00"
C	6"	6"	3 MT 58-28 S/H	3.50"	4 MT 58-28 S/H	2.00"

DATE	BY
REVISION	
DESIGNED BY: AJC	DATE: 5/13/2021 3:35 PM
SCALE: #####	
PROJECT NO: 13270	
CONTRACT NO: 8564	
DRAWING NO: D-3	

13270  
 MADISON, WI  
 8564  
 CONTRACT NO:  
 TYPICAL SECTIONS  
 FELLAND ROAD & TRANQUILITY TRAIL ROUNDABOUT  
 M:\DESIGN\Projects\13303\CAD\Streets\13270EN-FellandRAB-Details.dwg



13270  
 D-3



ROUNDBOUT DETAIL			
PNT	STA & OFF	ELEV.	COMMENT
001	22+00.00, -11.82LT	924.04	EP/PC/MATCH EX.
002	22+39.73, -18.16LT	925.40	EP/PT
003	22+89.59, -35.54LT	926.84	EP/PC
004	117+04.74, -54.28LT	927.09	EP/MC
005	117+17.73, -44.18LT	927.17	EP/PT/HI POINT
006	117+29.84, -38.11LT	927.11	EP/PC/LO POINT
007	117+56.68, -29.16LT	927.22	EP/CURB OPENING
008	117+62.74, -27.28LT	927.24	EP/MC
009	117+72.15, -24.09LT	927.29	EP/CURB OPENING
010	117+89.82, -20.80LT	927.38	EP/PRC/HI POINT
011	118+36.45, -16.84LT	926.98	EP/MC
101	117+90.03, 6.09RT	927.34	EP/LO POINT
102	117+65.34, 9.22RT	927.62	EP/MC
103	117+25.17, 24.14RT	928.15	EP/PRC/HI POINT
104	117+21.92, 23.75RT	928.13	EP/MC
105	117+20.97, 20.61RT	928.11	EP/PRC
106	117+23.67, 0.00	927.78	EP/MC
107	117+20.12, -20.48LT	927.57	EP/PRC
108	117+20.98, -23.69LT	927.54	EP/MC
109	117+24.27, -24.14LT	927.50	EP/PRC
110	117+43.23, -17.25LT	927.41	EP/LO POINT
111	117+57.13, -13.01LT	927.47	EP/MC
112	117+88.65, -5.85LT	927.63	EP/PT/HI POINT
113	118+11.45, -3.99LT	927.51	EP/PC
114	118+15.11, 0.00	927.48	EP/MC
115	118+11.45, 3.99RT	927.45	EP/PRC
116	117+60.41, 2.00RT		RAMP
117	117+45.62, 0.34RT		RAMP
201	118+34.02, 17.41RT	926.99	EP/MC
202	117+69.01, 23.85RT	927.65	EP/QC
203	117+64.20, 24.57RT	927.72	EP/CURB OPENING
204	117+52.92, 27.48RT	927.91	EP/CURB OPENING
205	117+15.57, 45.84RT	928.53	EP/PRC
206	117+06.27, 52.44RT	928.68	EP/MC
207	24+19.11, -45.92LT	928.91	EP/PT
208	24+37.69, -36.17LT	929.34	EP/PC
209	24+56.12, -29.37LT	929.71	EP/PT/END CURB
301	24+50.08, -15.19LT	929.61	EP/PC/BEGIN CURB
302	24+34.79, -20.87LT	929.18	EP/LO POINT
303	24+32.20, -22.13LT	929.20	EP/PRC
304	24+28.80, -21.79LT	929.22	EP/MC
305	24+27.88, -18.60LT	929.24	EP/PRC
306	24+30.99, -0.72LT	929.52	EP/HI POINT
307	24+31.02, 0.00	929.51	EP/MC
308	24+28.99, 18.76RT	929.20	EP/PRC
309	24+30.07, 21.85RT	929.19	EP/MC
310	24+33.33, 22.12RT	929.17	EP/PRC
311	24+35.98, 20.71RT	929.15	EP/LO POINT
312	24+49.88, 14.03RT	929.59	EP/PT/END CURB
401	24+54.88, 27.78RT	929.71	EP/PC/BEGIN CURB
402	24+36.78, 37.31RT	929.28	EP/PT
403	24+27.44, 42.62RT	929.02	EP/PC
404	116+02.96, 53.79RT	928.72	EP/MC
405	115+92.93, 46.00RT	928.49	EP/PT
406	115+78.85, 38.16RT	928.39	EP/PC
407	115+66.56, 32.65RT	928.33	EP/LO POINT
408	115+61.21, 31.17RT	928.35	EP/CURB OPENING
409	115+45.22, 26.77RT	928.42	EP/MC
410	115+42.37, 25.99RT	928.43	EP/CURB OPENING
411	115+13.59, 19.76RT	928.59	EP/PRC
501	115+75.25, -19.55LT	927.46	EP/LO POINT
502	115+85.11, -24.00LT	927.51	EP/PRC
503	115+88.36, -23.50LT	927.55	EP/MC
504	115+89.20, -20.32LT	927.58	EP/PRC
505	115+85.70, 0.00	927.76	EP/MC
506	115+88.36, 20.45RT	928.10	EP/PRC
507	115+87.37, 23.61RT	928.14	EP/MC
508	115+84.08, 23.93RT	928.19	EP/PRC/HI POINT
509	115+72.04, 18.57RT	928.12	EP/LO POINT
510	115+49.48, 12.15RT	928.24	EP/MC
511	115+14.59, 4.79RT	928.59	EP/PT
512	115+02.88, 3.99RT	928.71	EP/PC/HI POINT
513	114+99.16, 0.00	928.77	EP/MC
514	115+02.88, -3.99LT	928.54	EP/PRC
515	115+46.03, -8.58LT	927.92	EP/MC
516	115+67.35, -0.68LT		RAMP
517	115+52.45, -1.37LT		RAMP
601	115+10.86, -19.63LT	928.20	EP/MC
602	115+47.28, -24.24LT	927.68	EP/CURB OPENING
603	115+55.64, -26.95LT	927.54	EP/QC
604	115+58.37, -28.04LT	927.52	EP/CURB OPENING
605	115+98.10, -46.70LT	927.29	EP/PCC
606	116+06.81, -52.33LT	927.22	EP/MC
607	23+03.30, 46.54RT	926.95	EP/PT
608	22+84.36, 34.56RT	926.36	EP/PC
609	22+30.53, 17.47RT	924.95	EP/PT
610	22+00.00, 15.94RT	923.96	EP/MATCH EX.
701	22+46.68, 0.00	925.76	EP/MC
702	22+49.01, 2.92RT	925.91	EP/PRC
703	22+52.83, 3.87RT	925.85	EP/LO POINT
704	22+70.08, 9.31RT	926.25	EP/MC
705	22+89.79, 17.99RT	926.74	EP/PRC
706	22+93.03, 17.83RT	926.82	EP/MC
707	22+94.24, 14.83RT	926.90	EP/PRC/HI POINT
708	22+93.08, 0.00	926.77	EP/MC/LO POINT
709	22+95.12, -14.74LT	926.91	EP/PRC/HI POINT
710	22+94.12, -17.78LT	926.85	EP/MC
711	22+90.95, -18.19LT	926.80	EP/PRC
712	22+70.26, -9.10LT	926.42	EP/MC
713	22+49.01, -2.92LT	926.05	EP/PRC
714	22+55.14, -1.54LT		RAMP
715	22+77.28, -1.30LT		RAMP
801	117+05.67, 0.00	927.87	EP/VIPI
802	116+90.95, 37.29RT	928.51	EP
803	116+53.63, 52.41RT	929.16	EP/HI POINT
804	116+18.85, 37.71RT	928.53	EP
805	116+03.71, 0.00	927.85	EP/VIPI
806	116+20.31, -36.25LT	927.49	EP
807	116+59.85, -49.31LT	927.12	EP/LO POINT
808	116+86.45, -38.48LT	927.42	EP

- NOTES:
- 7" THICK CONCRETE SIDEWALK, WIDTH VARIES. SEE SHEETS P1-P4.
  - UNDERDRAIN
  - ASPHALT PATH. SEE TYPICAL SECTIONS.
  - SLOPED MEDIAN ISLAND NOSE PER S.D.D. 3.13. TYPICAL ON ALL ISLAND NOSES
  - END OF ROADWAY SIGNING PER S.D.D. 6.29
  - 5' ASPHALT TRANSITION FROM BACK-OF-CURB TO BACK-OF-CURB. CONSTRUCT ASPHALT CURB HEAD AND FLOWLINE TO MATCH CONCRETE CURB.
  - INSTALL CURB CUT FOR FUTURE RAMPS. DO NOT INSTALL PED RAMPS
  - ROUNDBOUT CENTER ISLAND LANDSCAPED WITH 18" PLANTING MIX TOPSOIL WITH 4" BARK MULCH PER SPECS

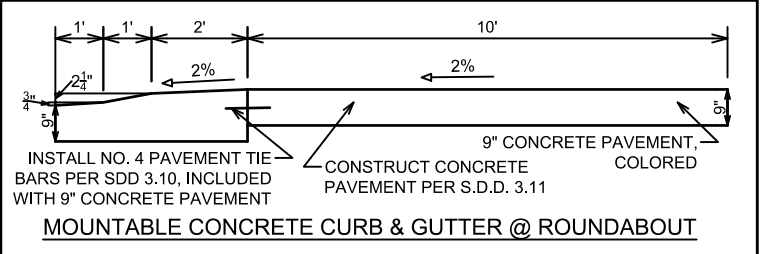
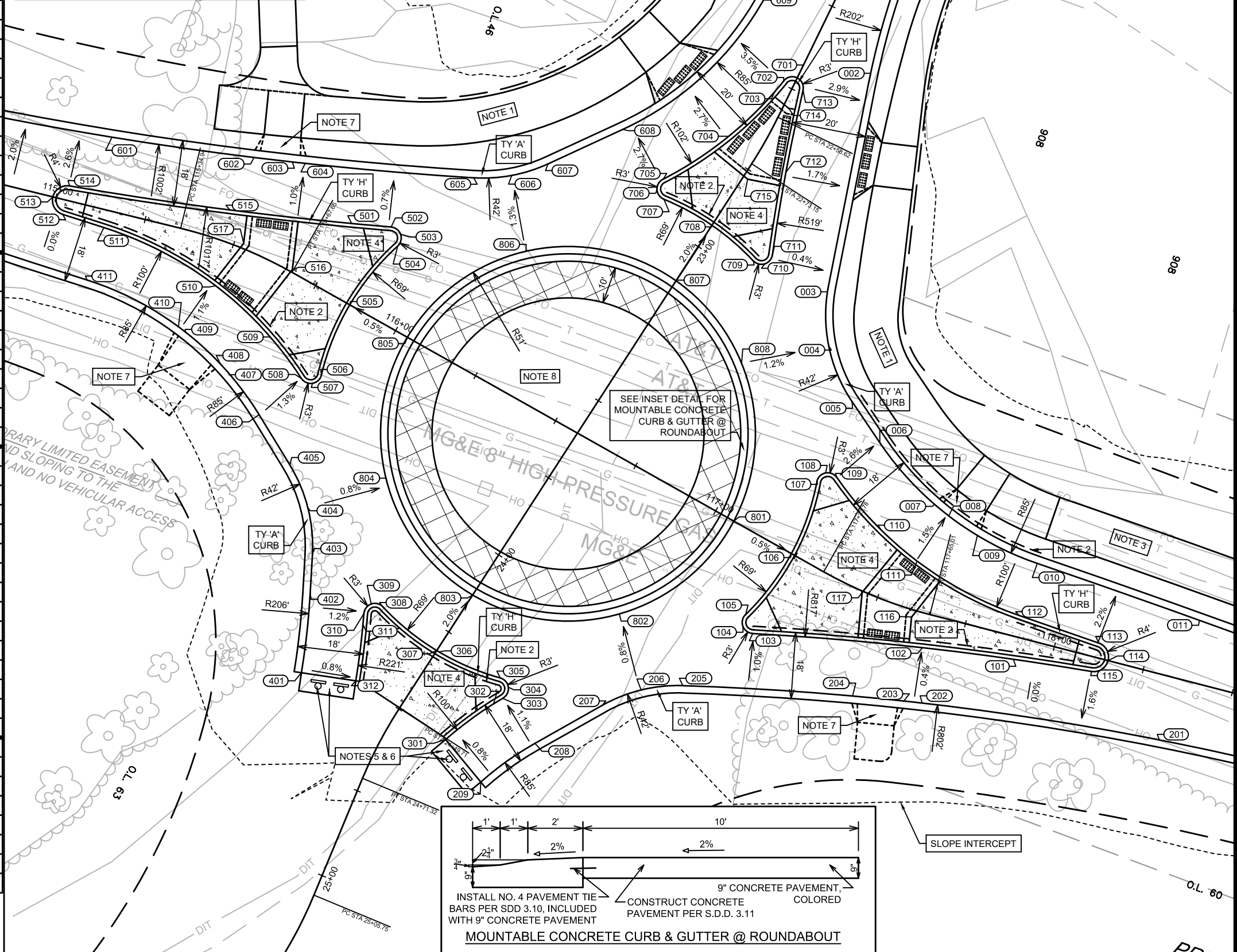
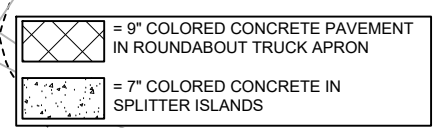





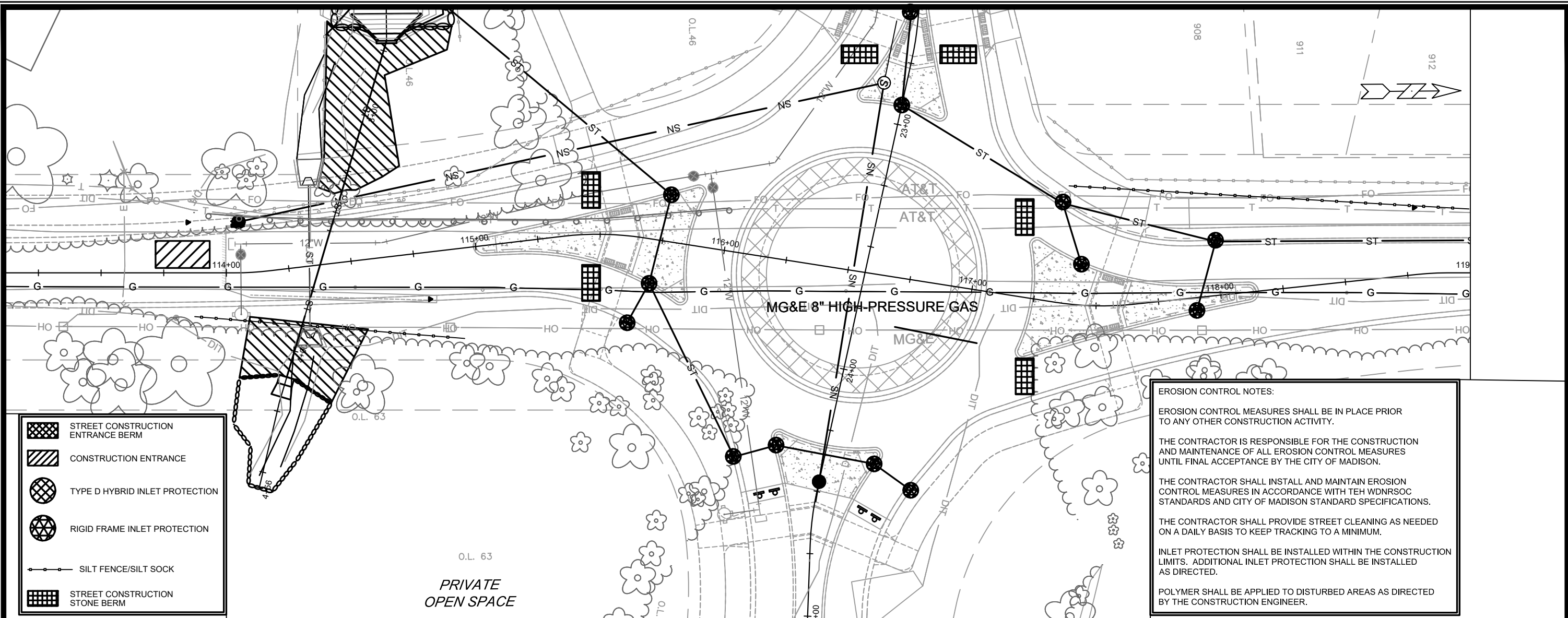

PROJECT NO.	13270
DATE	5/13/2021
REVISION	
MARK	
DESIGNED BY	AJC
SCALE	AS SHOWN
BY	D-4

CONTRACT NO.	8564
PROJECT NAME	FELLAND ROAD & TRANQUILITY TRAIL ROUNDBOUT
CITY	MADISON, WI
PROJECT ADDRESS	13303 CAD ST



-  STREET CONSTRUCTION ENTRANCE BERM
-  CONSTRUCTION ENTRANCE
-  TYPE D HYBRID INLET PROTECTION
-  RIGID FRAME INLET PROTECTION
-  SILT FENCE/SILT SOCK
-  STREET CONSTRUCTION STONE BERM

**EROSION CONTROL NOTES:**

EROSION CONTROL MEASURES SHALL BE IN PLACE PRIOR TO ANY OTHER CONSTRUCTION ACTIVITY.

THE CONTRACTOR IS RESPONSIBLE FOR THE CONSTRUCTION AND MAINTENANCE OF ALL EROSION CONTROL MEASURES UNTIL FINAL ACCEPTANCE BY THE CITY OF MADISON.

THE CONTRACTOR SHALL INSTALL AND MAINTAIN EROSION CONTROL MEASURES IN ACCORDANCE WITH TEH WDNRSOC STANDARDS AND CITY OF MADISON STANDARD SPECIFICATIONS.

THE CONTRACTOR SHALL PROVIDE STREET CLEANING AS NEEDED ON A DAILY BASIS TO KEEP TRACKING TO A MINIMUM.

INLET PROTECTION SHALL BE INSTALLED WITHIN THE CONSTRUCTION LIMITS. ADDITIONAL INLET PROTECTION SHALL BE INSTALLED AS DIRECTED.

POLYMER SHALL BE APPLIED TO DISTURBED AREAS AS DIRECTED BY THE CONSTRUCTION ENGINEER.

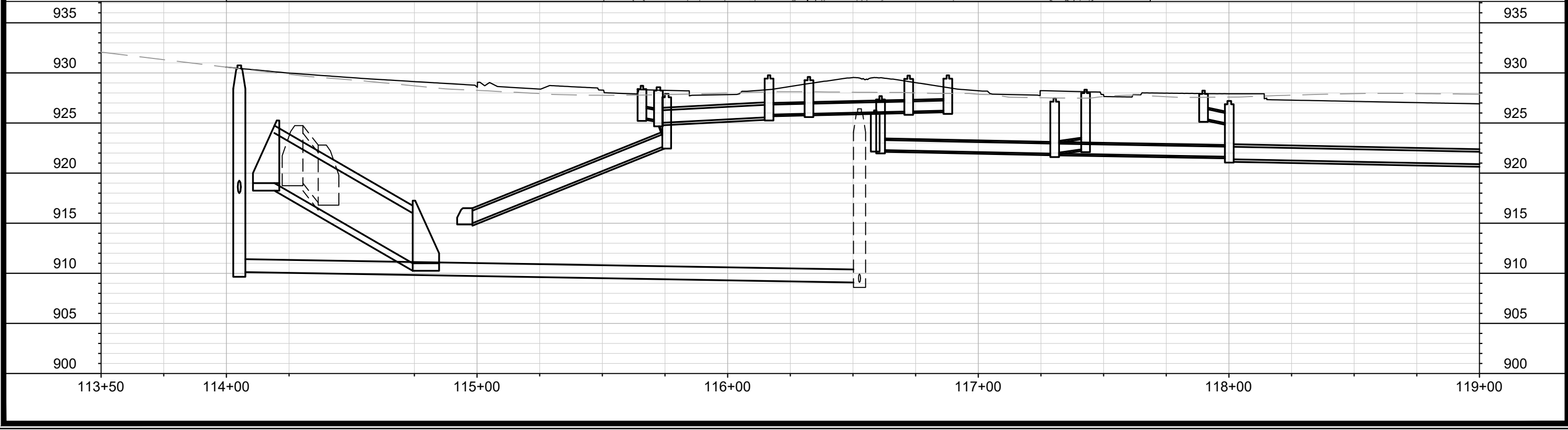

MARK	REVISION	DATE	BY
13270		5/13/2021 5:32 PM	

13270  
MADISON, WI  
8564  
CONTRACT NO:

EROSION CONTROL PLAN  
FELLAND ROAD & TRANQUILITY TRAIL ROUNDABOUT  
M:\DESIGN\Projects\13270\CAD\Sewers\13270SWR-PipeNetwork.dwg



13270  
EC-1

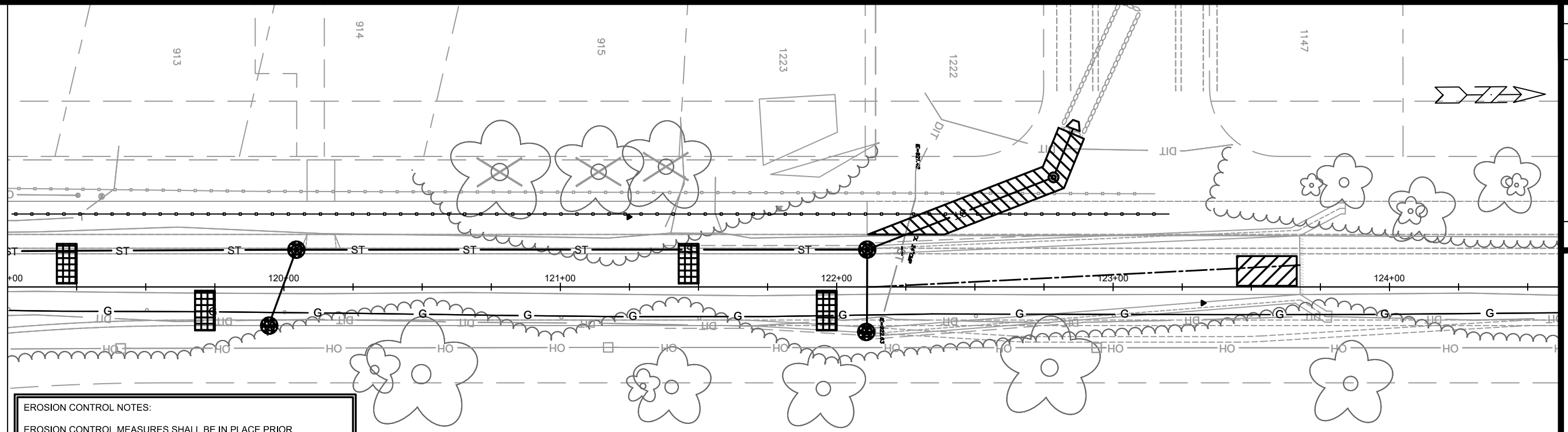

**EROSION CONTROL NOTES:**

EROSION CONTROL MEASURES SHALL BE IN PLACE PRIOR TO ANY OTHER CONSTRUCTION ACTIVITY.







THE CONTRACTOR IS RESPONSIBLE FOR THE CONSTRUCTION AND MAINTENANCE OF ALL EROSION CONTROL MEASURES UNTIL FINAL ACCEPTANCE BY THE CITY OF MADISON.

THE CONTRACTOR SHALL INSTALL AND MAINTAIN EROSION CONTROL MEASURES IN ACCORDANCE WITH THE WDNR SOC STANDARDS AND CITY OF MADISON STANDARD SPECIFICATIONS.

THE CONTRACTOR SHALL PROVIDE STREET CLEANING AS NEEDED ON A DAILY BASIS TO KEEP TRACKING TO A MINIMUM.

INLET PROTECTION SHALL BE INSTALLED WITHIN THE CONSTRUCTION LIMITS. ADDITIONAL INLET PROTECTION SHALL BE INSTALLED AS DIRECTED.

POLYMER SHALL BE APPLIED TO DISTURBED AREAS AS DIRECTED BY THE CONSTRUCTION ENGINEER.

-  STREET CONSTRUCTION ENTRANCE BERM
-  CONSTRUCTION ENTRANCE
-  TYPE D HYBRID INLET PROTECTION
-  RIGID FRAME INLET PROTECTION
-  SILT FENCE/SILT SOCK
-  STREET CONSTRUCTION STONE BERM

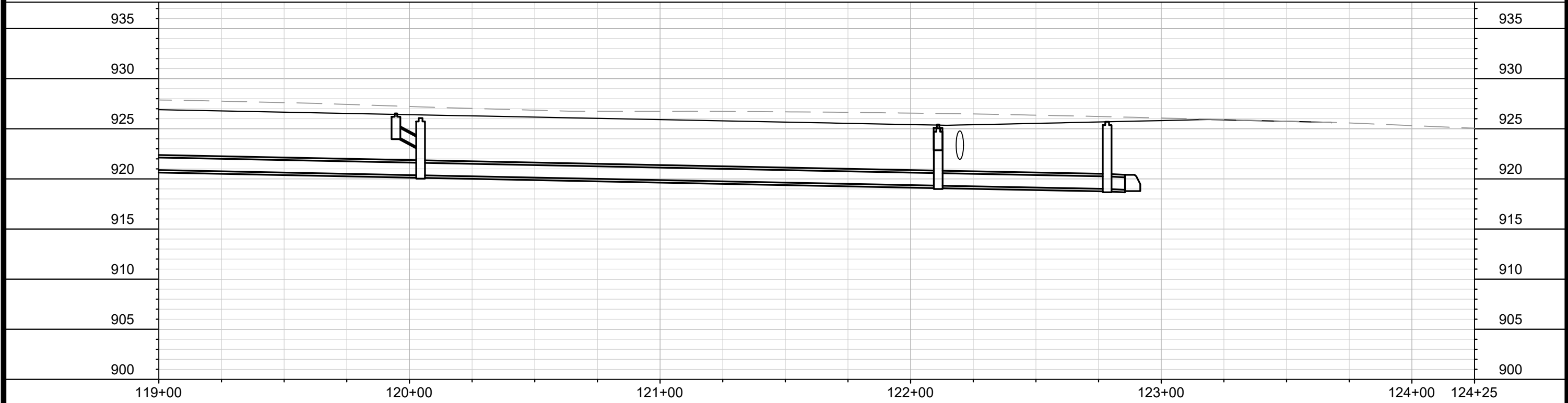

MARK	REVISION	DATE	BY	
Designed By: MAA	Date: 5/13/2021 5:32 PM			Scale: 40:1
13270				
13270		MADISON, WI		8564
EROSION CONTROL PLAN				
FELLAND ROAD & TRANQUILITY TRAIL ROUNDABOUT				
M:\DESIGN\Projects\13270\CAD\Sewers\13270SWR-PipeNetwork.dwg				
				
13270				
EC-2				

	STREET CONSTRUCTION ENTRANCE BERM
	CONSTRUCTION ENTRANCE
	TYPE D HYBRID INLET PROTECTION
	RIGID FRAME INLET PROTECTION
	SILT FENCE/SILT SOCK
	STREET CONSTRUCTION STONE BERM

**EROSION CONTROL NOTES:**

EROSION CONTROL MEASURES SHALL BE IN PLACE PRIOR TO ANY OTHER CONSTRUCTION ACTIVITY.

THE CONTRACTOR IS RESPONSIBLE FOR THE CONSTRUCTION AND MAINTENANCE OF ALL EROSION CONTROL MEASURES UNTIL FINAL ACCEPTANCE BY THE CITY OF MADISON.

THE CONTRACTOR SHALL INSTALL AND MAINTAIN EROSION CONTROL MEASURES IN ACCORDANCE WITH TEH WDNRSOC STANDARDS AND CITY OF MADISON STANDARD SPECIFICATIONS.

THE CONTRACTOR SHALL PROVIDE STREET CLEANING AS NEEDED ON A DAILY BASIS TO KEEP TRACKING TO A MINIMUM.

INLET PROTECTION SHALL BE INSTALLED WITHIN THE CONSTRUCTION LIMITS. ADDITIONAL INLET PROTECTION SHALL BE INSTALLED AS DIRECTED.

POLYMER SHALL BE APPLIED TO DISTURBED AREAS AS DIRECTED BY THE CONSTRUCTION ENGINEER.

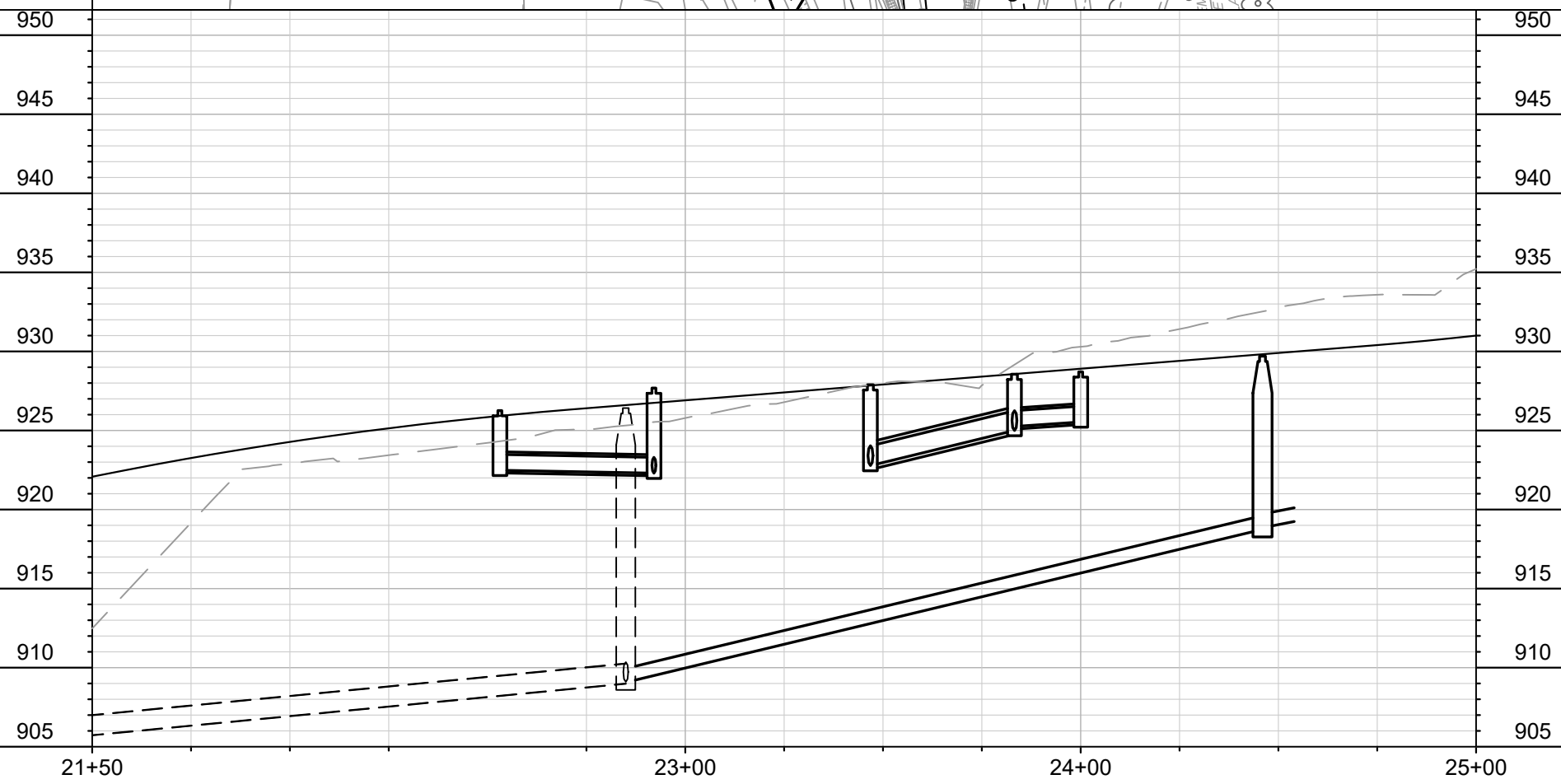
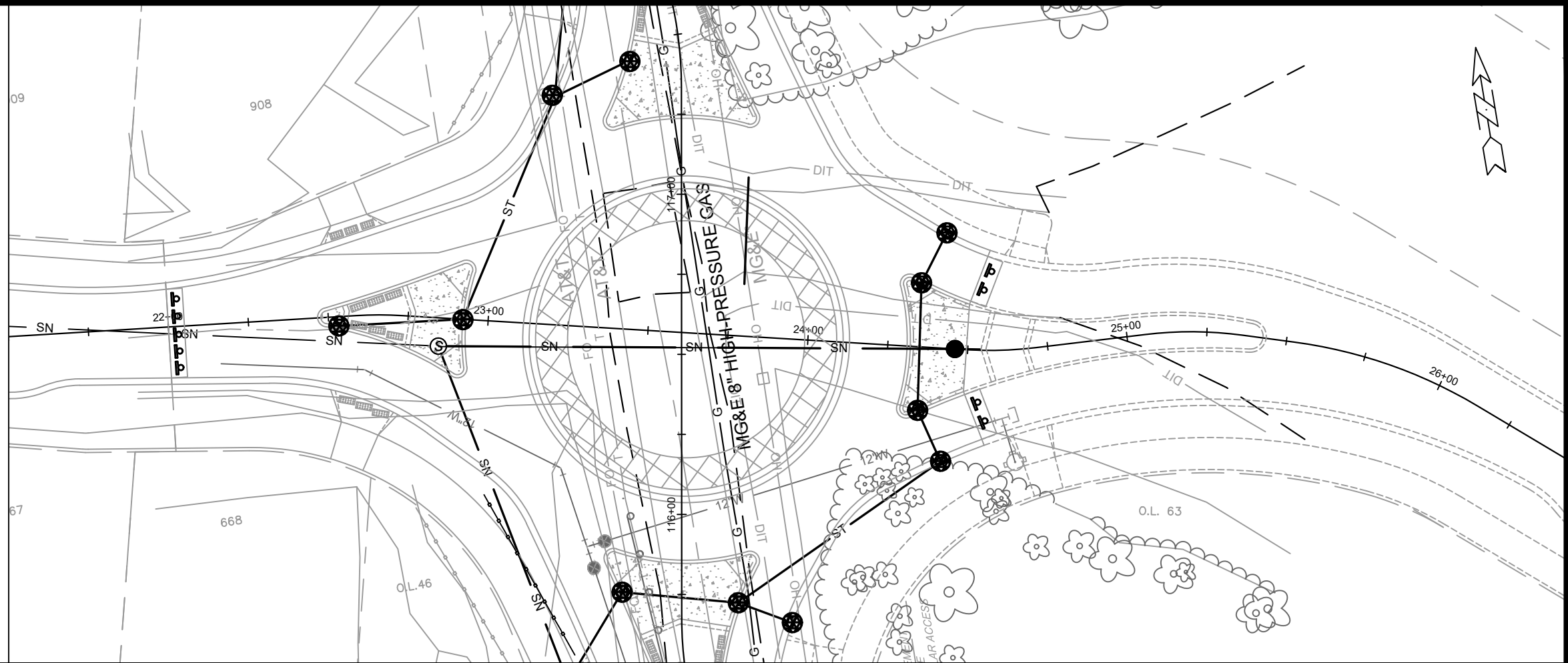

DATE	BY
REVISION	
Designed By: MAA	Date: 5/13/2021 5:38 PM
Scale: 40:1	
MARK	13270

13270  
 MADISON, WI  
 FELLAND ROAD & TRANQUILITY TRAIL ROUNDABOUT  
 CONTRACT NO: 8564  
 M:\DESIGN\Projects\13303\CAD\Sewers\13270SWR-Tranquility.dwg



13270  
 EC-3

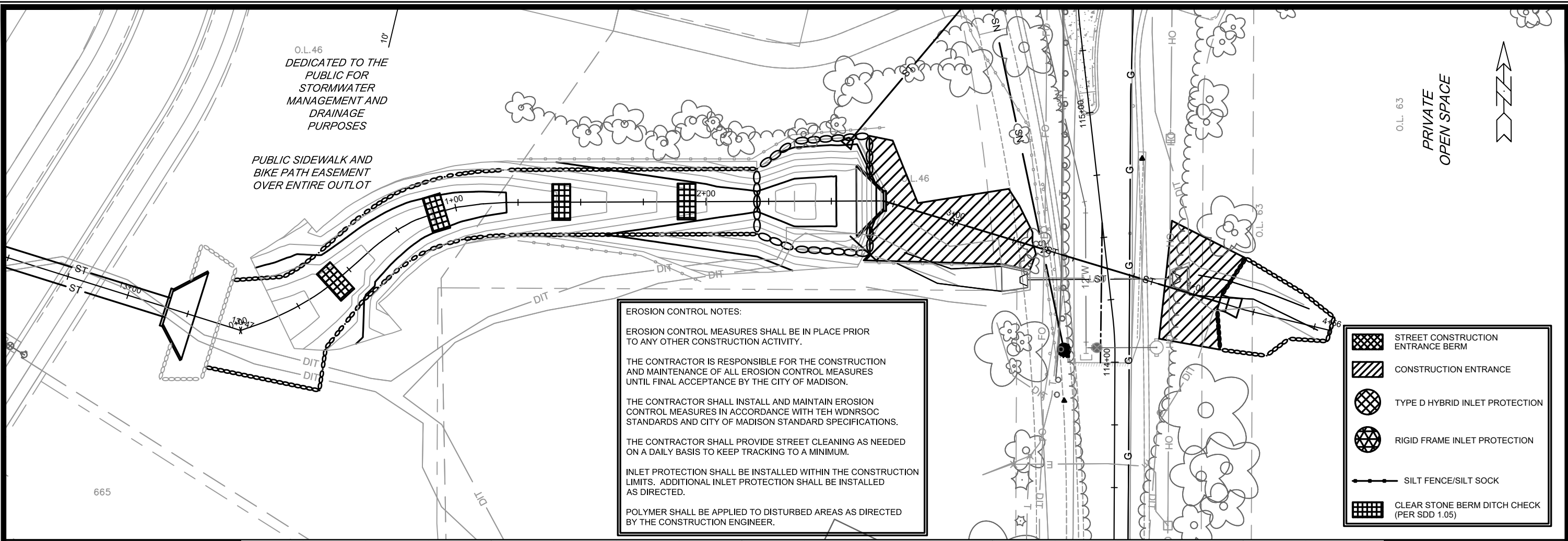

O.L. 46  
DEDICATED TO THE  
PUBLIC FOR  
STORMWATER  
MANAGEMENT AND  
DRAINAGE  
PURPOSES

PUBLIC SIDEWALK AND  
BIKE PATH EASEMENT  
OVER ENTIRE OUTLOT

O.L. 63  
PRIVATE  
OPEN SPACE

**EROSION CONTROL NOTES:**

EROSION CONTROL MEASURES SHALL BE IN PLACE PRIOR TO ANY OTHER CONSTRUCTION ACTIVITY.







THE CONTRACTOR IS RESPONSIBLE FOR THE CONSTRUCTION AND MAINTENANCE OF ALL EROSION CONTROL MEASURES UNTIL FINAL ACCEPTANCE BY THE CITY OF MADISON.

THE CONTRACTOR SHALL INSTALL AND MAINTAIN EROSION CONTROL MEASURES IN ACCORDANCE WITH THE WDNRSOC STANDARDS AND CITY OF MADISON STANDARD SPECIFICATIONS.

THE CONTRACTOR SHALL PROVIDE STREET CLEANING AS NEEDED ON A DAILY BASIS TO KEEP TRACKING TO A MINIMUM.

INLET PROTECTION SHALL BE INSTALLED WITHIN THE CONSTRUCTION LIMITS. ADDITIONAL INLET PROTECTION SHALL BE INSTALLED AS DIRECTED.

POLYMER SHALL BE APPLIED TO DISTURBED AREAS AS DIRECTED BY THE CONSTRUCTION ENGINEER.

-  STREET CONSTRUCTION ENTRANCE BERM
-  CONSTRUCTION ENTRANCE
-  TYPE D HYBRID INLET PROTECTION
-  RIGID FRAME INLET PROTECTION
-  SILT FENCE/SILT SOCK
-  CLEAR STONE BERM DITCH CHECK (PER SDD 1.05)

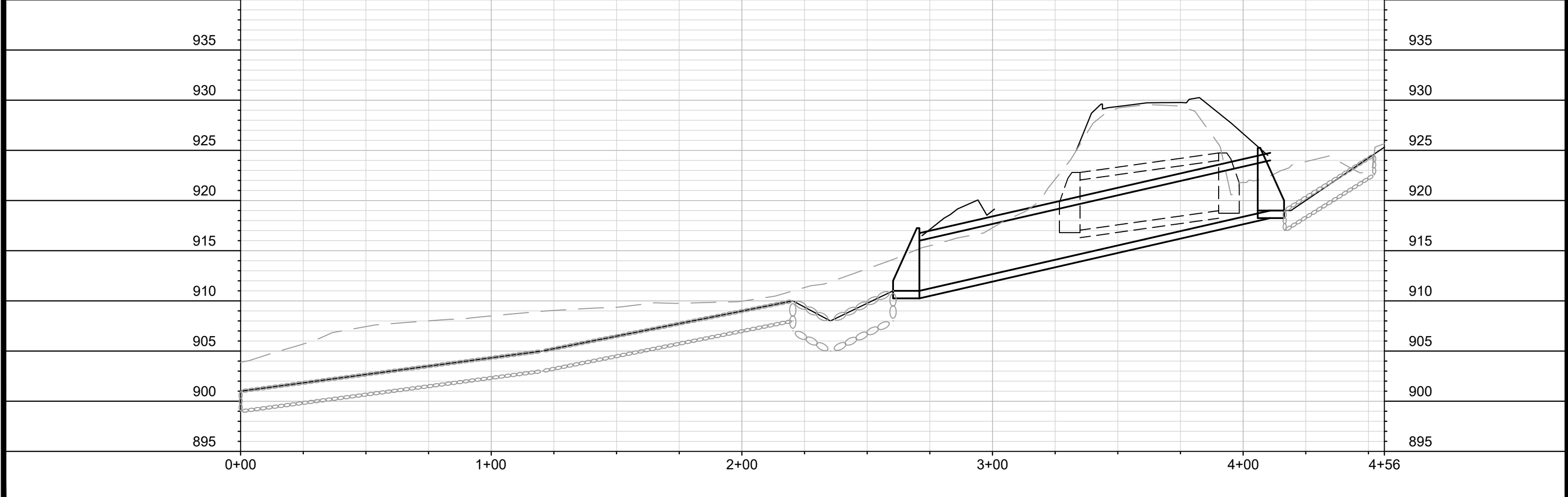

MARK	REVISION	DATE	BY

Designed By: MAA  
Date: 5/13/2021 5:32 PM  
Scale: #####

13270  
MADISON, WI  
8564  
CONTRACT NO.:

EROSION CONTROL PLAN  
FELLAND ROAD & TRANQUILITY TRAIL ROUNDABOUT  
M:\DESIGN\Projects\13270\CAD\Sewers\13270SWR-PipeNetwork.dwg



13270  
EC-4



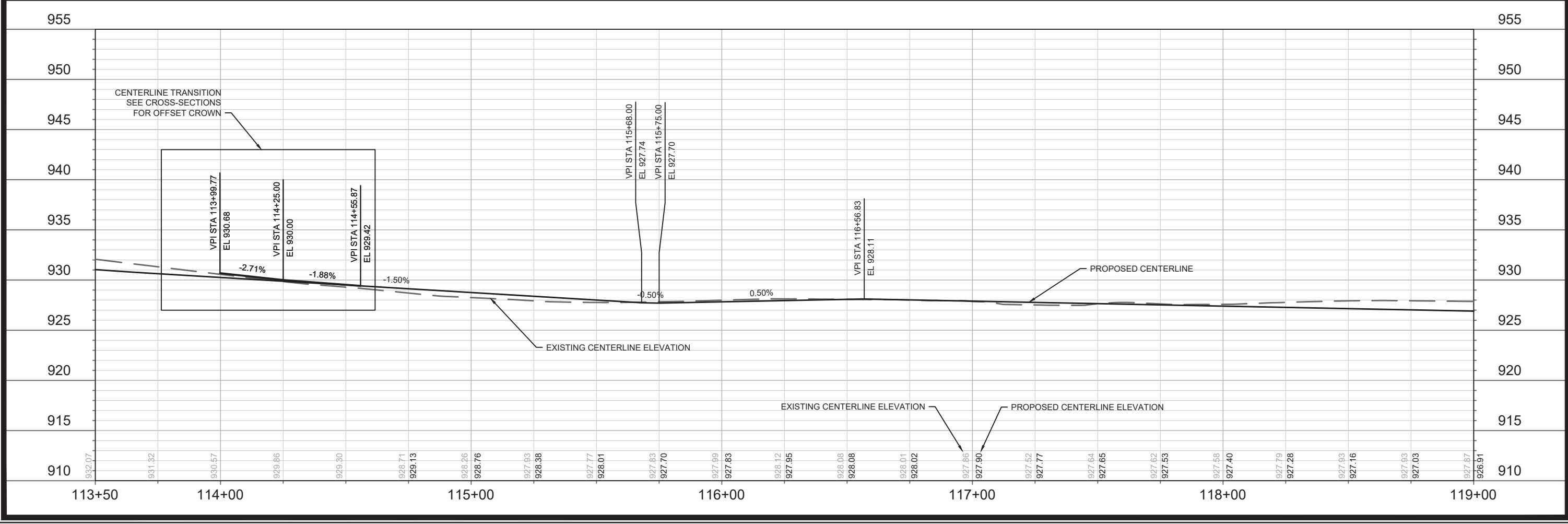
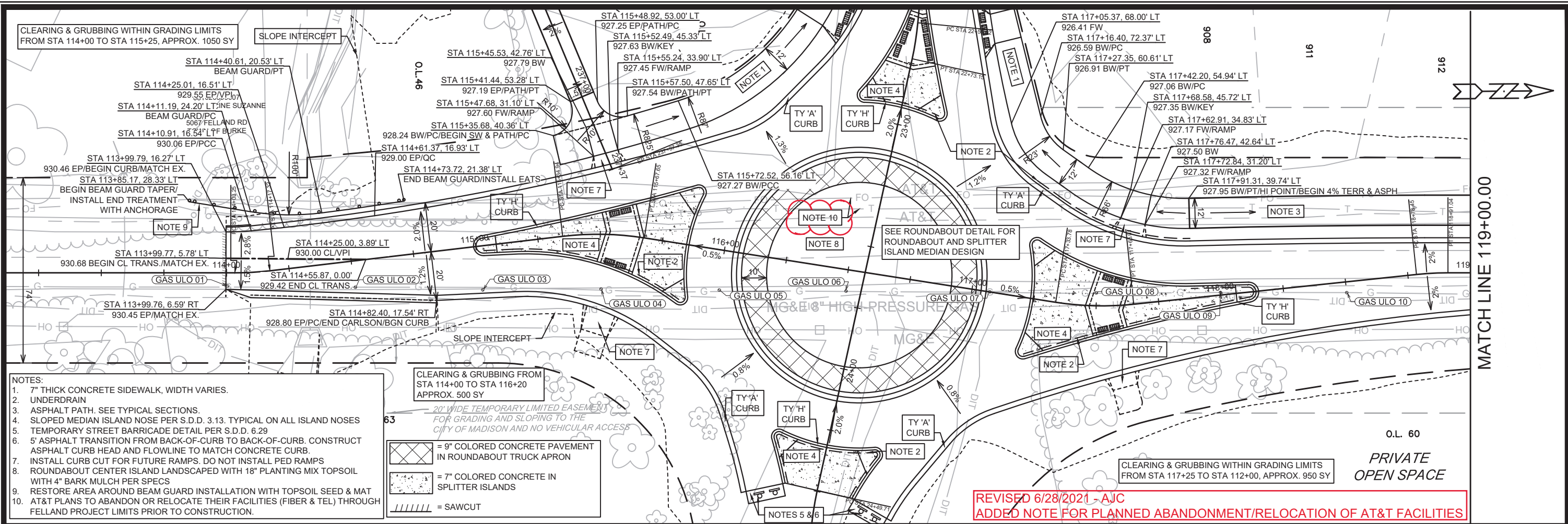

13270	MADISON, WI	8564	CONTRACT NO:
<b>FELLAND ROAD - PLAN &amp; PROFILE</b> <b>FELLAND ROAD &amp; TRANQUILITY TRAIL ROUNDABOUT</b>			
M:\DESIGN\Projects\13303\CAD\Streets\13270EN-FellandRAB-Pn-P.dwg			
13270		P-1	

MATCH LINE 119+00.00

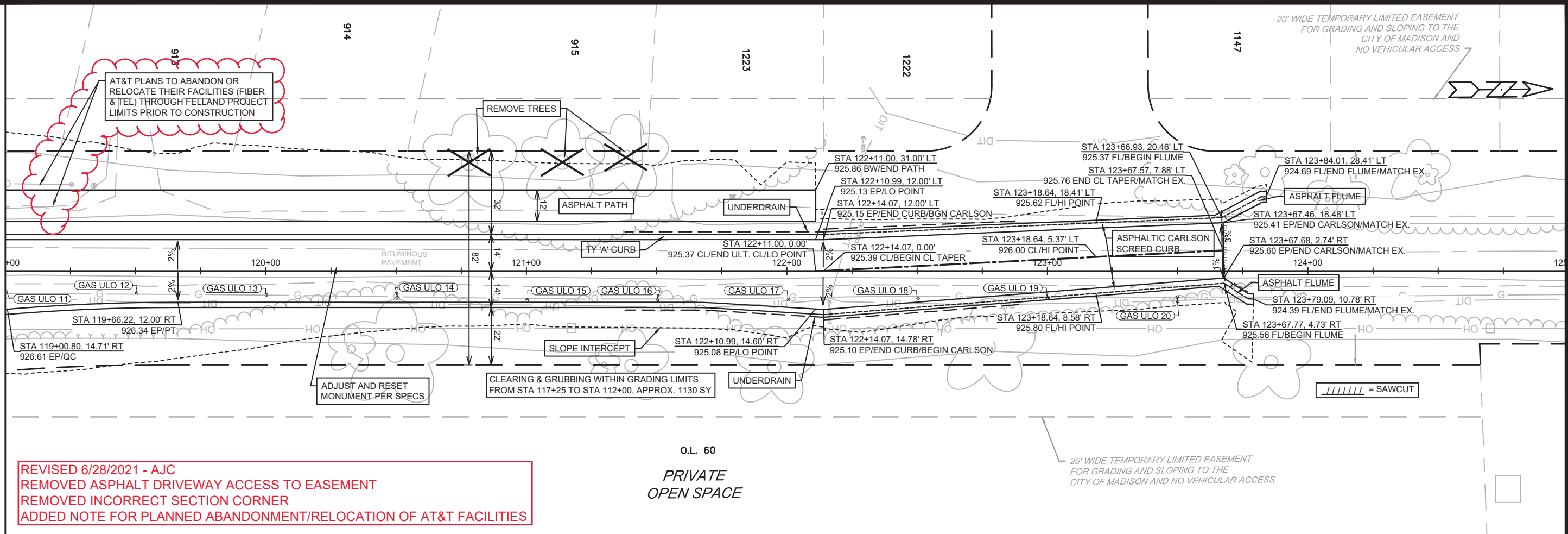

REVISED 6/28/2021 - AJC  
 REMOVED ASPHALT DRIVEWAY ACCESS TO EASEMENT  
 REMOVED INCORRECT SECTION CORNER  
 ADDED NOTE FOR PLANNED ABANDONMENT/RELOCATION OF AT&T FACILITIES

O.L. 60  
 PRIVATE  
 OPEN SPACE

/////// = SAWCUT

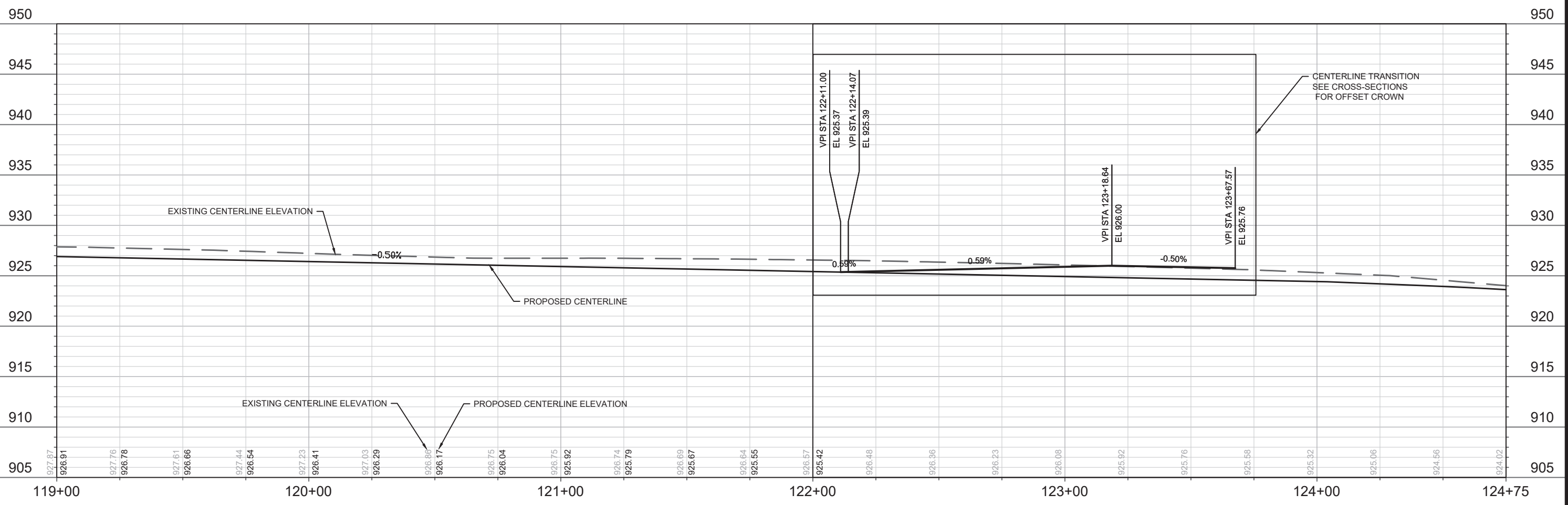

DATE	BY	P-2
REVISION		
Designed By: AJC	Date: 6/28/2021 1:31 PM	Scale: #####
MARK	13270	

13270  
 MADISON, WI  
 CONTRACT NO: 8564

FELLAND ROAD - PLAN & PROFILE  
 FELLAND ROAD & TRANQUILITY TRAIL ROUNDABOUT  
 M:\DESIGN\Projects\13303\CAD\Streets\13270EN-FellandRAB-Pn-P.dwg

13270  
 P-2



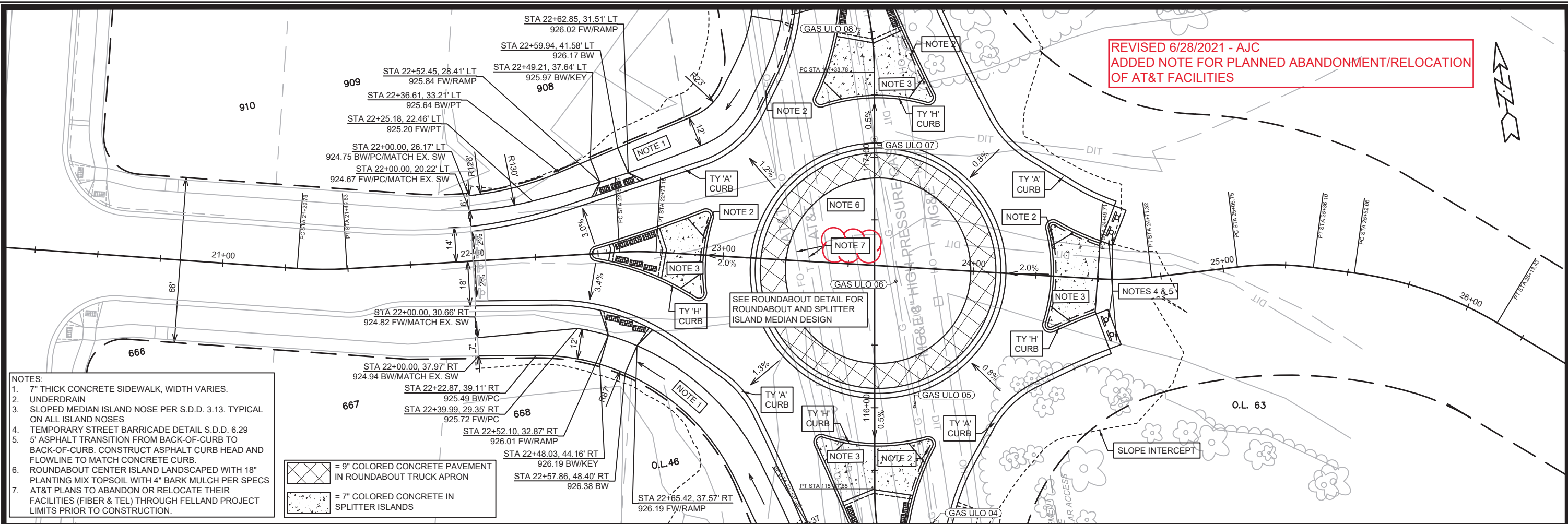

REVISED 6/28/2021 - AJC  
 ADDED NOTE FOR PLANNED ABANDONMENT/RELOCATION  
 OF AT&T FACILITIES

- NOTES:
- 7" THICK CONCRETE SIDEWALK, WIDTH VARIES.
  - UNDERDRAIN
  - SLOPED MEDIAN ISLAND NOSE PER S.D.D. 3.13. TYPICAL ON ALL ISLAND NOSES
  - TEMPORARY STREET BARRICADE DETAIL S.D.D. 6.29
  - 5' ASPHALT TRANSITION FROM BACK-OF-CURB TO BACK-OF-CURB. CONSTRUCT ASPHALT CURB HEAD AND FLOWLINE TO MATCH CONCRETE CURB.
  - ROUNDBOUT CENTER ISLAND LANDSCAPED WITH 18" PLANTING MIX TOPSOIL WITH 4" BARK MULCH PER SPECS AT&T PLANS TO ABANDON OR RELOCATE THEIR FACILITIES (FIBER & TEL) THROUGH FELLAND PROJECT LIMITS PRIOR TO CONSTRUCTION.

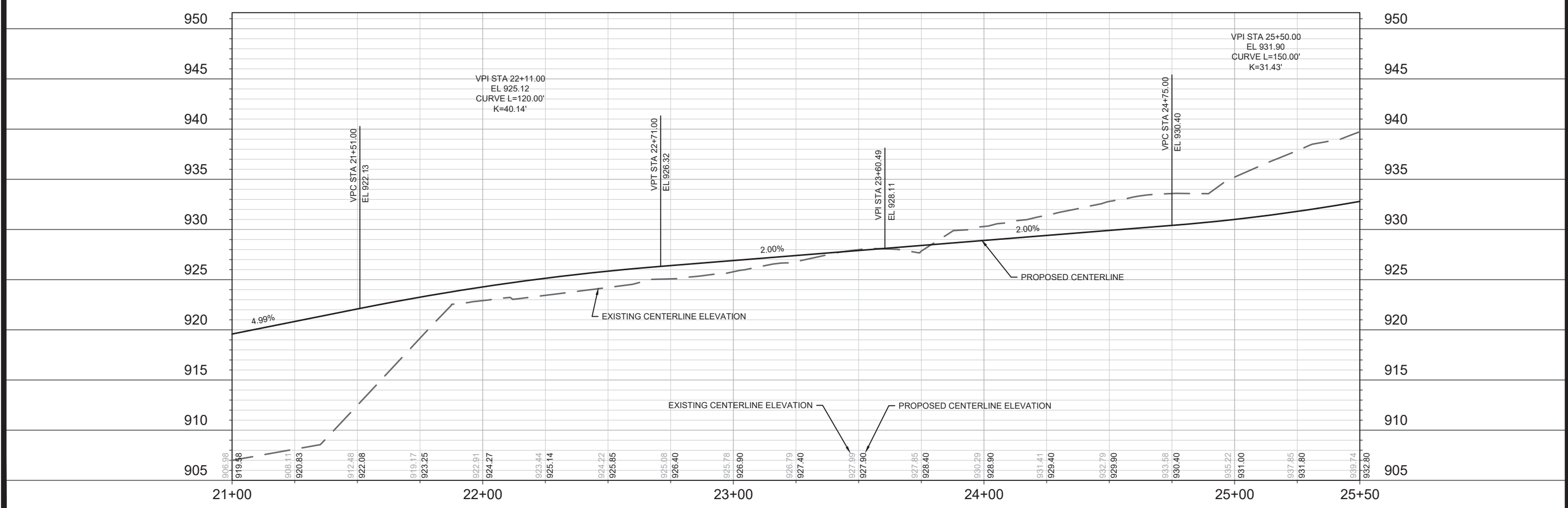

DATE	BY	P-3
REVISION		
Scale: #####		
Designed By: AJC	Date: 6/28/2021 1:31 PM	
MARK	13270	
CONTRACT NO:	8564	
PROJECT NAME:	MADISON, WI	
PROJECT NO:	13270	
CITY OF MADISON WISCONSIN		
PROJECT TITLE:	TRANQUILITY TRAIL - PLAN & PROFILE	
PROJECT TITLE:	FELLAND ROAD & TRANQUILITY TRAIL ROUNDBOUT	
PROJECT FILE:	M:\DESIGN\Projects\13303\CAD\Streets\13270\EN-FellandRAB-PnP.dwg	
PROJECT NO:	13270	
PROJECT NO:	P-3	

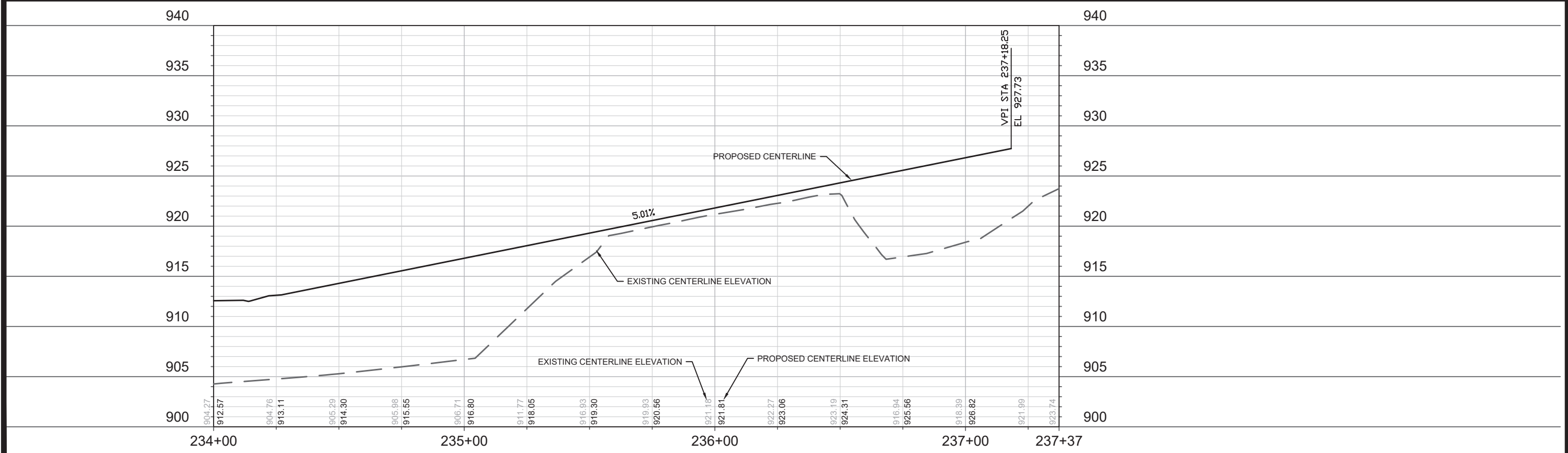
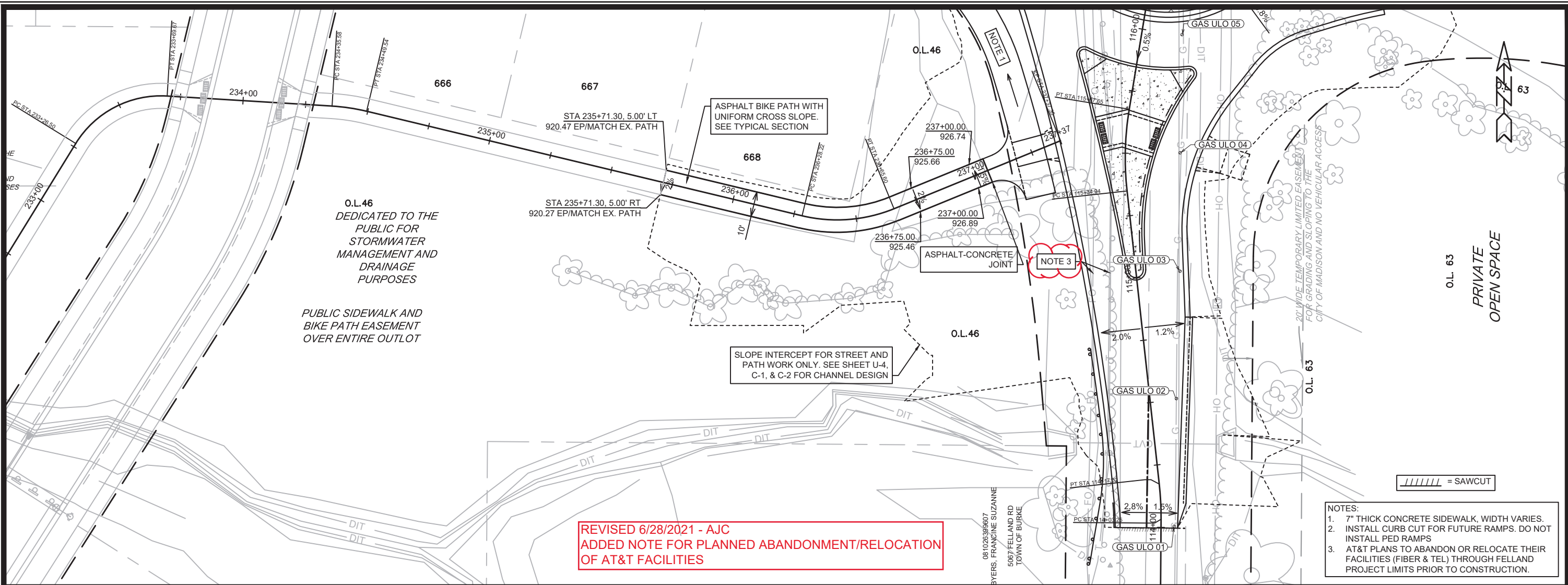

- NOTES:
- 7" THICK CONCRETE SIDEWALK, WIDTH VARIES.
  - INSTALL CURB CUT FOR FUTURE RAMPS. DO NOT INSTALL PED RAMPS
  - AT&T PLANS TO ABANDON OR RELOCATE THEIR FACILITIES (FIBER & TEL) THROUGH FELLAND PROJECT LIMITS PRIOR TO CONSTRUCTION.

MARK	REVISION	DATE	BY

13270  
MADISON, WI  
8564  
CONTRACT NO:

OL 46 PATH - PLAN & PROFILE  
FELLAND ROAD & TRANQUILITY TRAIL ROUNDABOUT  
M:\DESIGN\Projects\13303\CAD\Streets\13270EN-FellandRAB-Pn-P.dwg





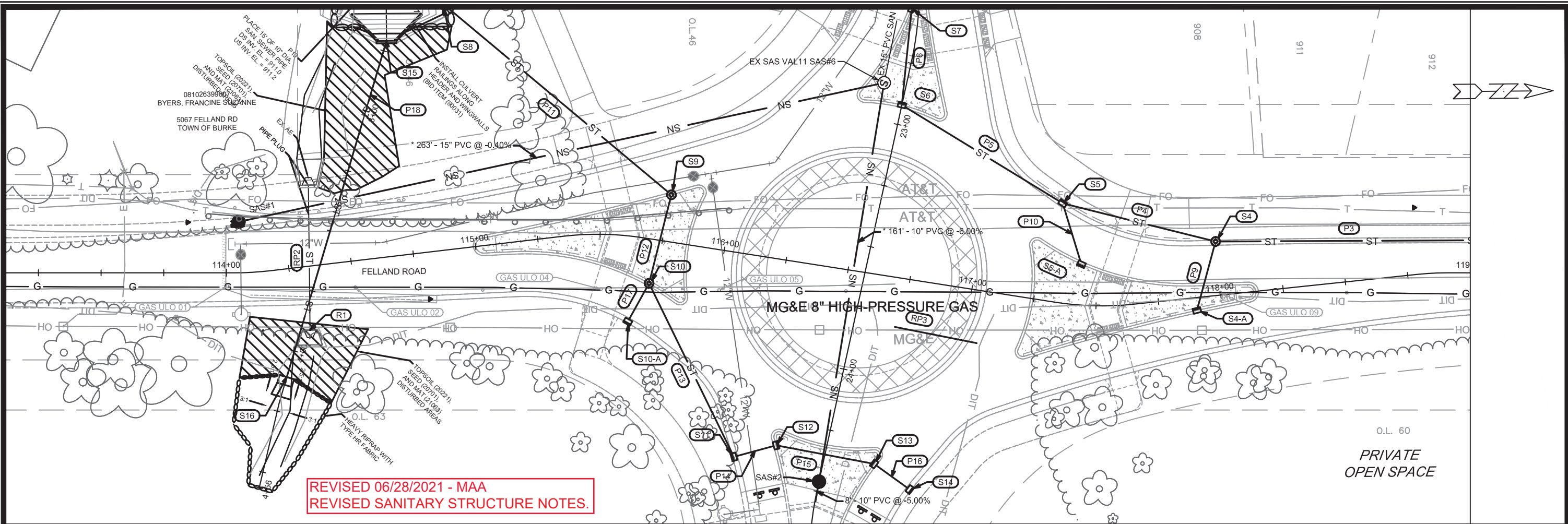

REVISED 06/28/2021 - MAA  
REVISED SANITARY STRUCTURE NOTES.

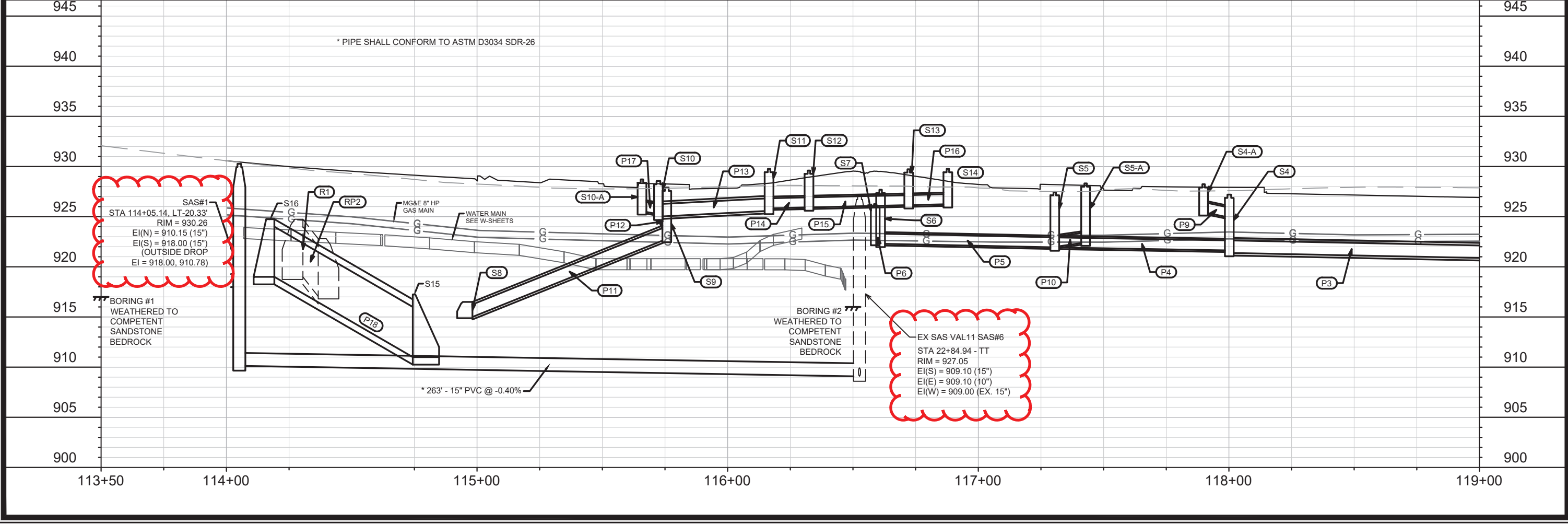

SAS#1  
STA 114+05.14, LT-20.33'  
RIM = 930.26  
EI(N) = 910.15 (15")  
EI(S) = 918.00 (15")  
(OUTSIDE DROP  
EI = 918.00, 910.78)

EX SAS VAL11 SAS#6  
STA 22+84.94 - TT  
RIM = 927.05  
EI(S) = 909.10 (15")  
EI(E) = 909.10 (10")  
EI(W) = 909.00 (EX. 15")

13270	13270	13270	13270
REMOVED ULOS CORRECTED SANITARY ELEVATIONS	REVISION	DATE	BY
MAA	MAA	06/24/2021	MAA
Designed By: MAA	Date: 06/24/2021	3:51 PM	Scale: #####
13270	8564	CONTRACT NO:	
UTILITY PLAN AND PROFILE - FELLAND ROAD			
FELLAND ROAD & TRANQUILITY TRAIL ROUNDABOUT			
M:\DESIGN\Projects\13270\CAD\Sewers\13270SWR-PipeNetwork.dwg			
CITY OF MADISON WISCONSIN			
13270			
U-1			









# SANITARY SEWER SCHEDULE

FELLAND ROAD PROJECT NO. 13270	SHEET NO. U-5
SANITARY SEWER SCHEDULE	
CITY OF MADISON	

## PROPOSED SANITARY STRUCTURES

SAS NO.	STATION	LOCATION (OFFSET)	TOP OF CASTING	E.I.	DEPTH	NOTES
<b>FELLAND ROAD</b>						
SAS#1	114+05.14	LT-20.3'	930.26	910.15	20.11	[1]
<b>TRANQUILITY TRAIL</b>						
SAS#2	24+46.00	CL	929.70	918.76	10.94	-

## PROPOSED SANITARY PIPES

FROM (DNSTM)	TO (UPSTM)	DWNSTRM E.I.	UPSTRM E.I.	PLAN LGTH (FT)	SLOPE (%)	PIPE SIZE	PVC TYPE	NOTES
<b>FELLAND ROAD</b>								
VAL11 SAS#6	SAS#1	909.10	910.15	263	0.40%	15"	SDR-26	-
<b>TRANQUILITY TRAIL</b>								
VAL11 SAS#6	SAS#2	909.10	918.76	161	6.00%	10"	SDR-26	-
SAS#2	STUB	918.86	919.26	8	5.00%	10"	SDR-26	[2]

## EXISTING SANITARY STRUCTURES

SAS NO.	STATION	LOCATION (OFFSET)	TOP OF CASTING	E.I.	DEPTH	NOTES
<b>TRANQUILITY TRAIL</b>						
VAL11 SAS#6	22+84.94	RT-8.8'	927.05	909.00	18.05	-

## OUTSIDE DROPS

SAS NO.	STATION	LOCATION (OFFSET)	PIPE SIZE	E.I.	E.I.	DROP (V.F.)	PAY QUANT.	NOTES
<b>FELLAND ROAD</b>								
SAS#1	114+05.14	LT-20.3'	15"	918.00	910.78	7.22	7.22	[1]

## SPECIFIC NOTES:

- [1] INSTALL OUTSIDE DROP IN ACCORDANCE WITH DETAIL A IN SDD 5.7.2
- [2] EXTEND 10" SDR-26 PVC 8' TO EAST, PLUG AND MARK END WITH 4"X4" POST

# STORM SEWER SCHEDULE

STORM SEWER SCHEDULE

CITY OF MADISON

## PROPOSED STORM STRUCTURES

STRUC. NO.	STATION	LOCATION (OFFSET)	TYPE	TOP OF CASTING	E.I.	DEPTH	NOTES
<b>FELLAND ROAD</b>							
S0	122+85.53	LT-57.3	15" RC AE	-	918.91	-	[1]; SEE SDD 5.4.1
S1	122+78.41	LT-39.7	3X3 AS	925.70	919.00	6.70	w/ R-1550-0054
S2	122+11.01	LT-13.5	3X3 AS	925.51	919.33	6.18	<b>LP; UD; w/ R-3067-7004-VB</b>
S2-A	122+10.95	RT-16.1	H INLET	925.44	923.19	2.25	<b>FP; LP; UD; w/ R-3067-7004-VB</b>
S3	120+04.46	LT-13.5	3X3 AS	926.53	920.36	6.17	w/ R-3067-7004-V
S3-A	119+94.63	RT-13.5	H INLET	926.58	924.30	2.28	FP; w/ R-3067-7004-V
S4	118+00.15	LT-21.5	3X3 AS	927.67	921.39	6.28	w/ R-3067-7004-V
S4-A	117+89.90	RT-5.1	H INLET	927.78	925.45	2.33	FP; LP; UD; w/ R-3067-7009-L
<b>S5</b>	117+30.51	LT-39.5	<b>H INLET</b>	927.48	921.94	5.54	<b>LP; UD; w/ R-3067-7004-VB</b>
<b>S5-A</b>	117+42.84	LT-16.3	<b>H INLET</b>	927.85	922.43	5.42	LP; w/ R-3067-7009-L
<b>S6</b>	116+61.03	LT-68.3	<b>H INLET</b>	927.21	922.30	4.91	LP; UD; w/ R-3067-7009-L
<b>S7</b>	116+58.91	LT-107.0	<b>H INLET</b>	926.29	922.48	3.81	LP; w/ R-3067-7009-L
S8	114+98.17	LT-98.1	15" RCP AE	-	915.00	-	[1]; SEE SDD 5.4.1
S9	115+75.71	LT-18.6	3X3 AS	927.89	922.78	5.11	LP; w/ R-3067-7009-L
S10	115+72.38	RT-17.6	3X3 AS	928.56	925.00	3.56	LP; UD; w/ R-3067-7009-L
S10-A	115+65.82	RT-34.1	PRECAST H INLET	928.71	925.54	3.17	<b>LP; w/ R-3067-7004-VB</b>
S11	116+16.53	RT-80.8	H INLET	929.80	925.58	4.22	w/ R-3067-7004-V
S12	116+32.46	RT-73.7	PRECAST H INLET	929.59	925.92	3.67	LP; UD; w/ R-3067-7009-L
S13	116+72.26	RT-74.9	PRECAST H INLET	929.63	926.15	3.48	LP; UD; w/ R-3067-7009-L
S14	116+87.88	RT-82.9	PRECAST H INLET	929.78	926.24	3.54	w/ R-3067-7004-V
S15	114+74.35	LT-85.7	WINGWALL APRON	-	911.00	-	[2]; [3]
S16	114+19.13	RT-42.9	60" RCP AE	-	919.00	-	[4]; SEE SDD 5.4.1

## PROPOSED STORM PIPES

PIPE NO.	FROM (DISCH.)	TO (INLET)	DISCH. E.I.	INLET E.I.	PLAN (PAY) LGTH (FT)	PIPE LGTH (FT)	SLOPE (%)	PIPE SIZE	PIPE TYPE	NOTES
<b>FELLAND ROAD</b>										
P0	S0	S1	918.91	919.00	19.0	17.5	0.50%	15"	TYPE I	-
P1	S1	S2	919.00	919.33	70.1	67.1	0.50%	15"	TYPE I	-
P2	S2	S3	919.33	920.36	206.6	203.6	0.50%	15"	TYPE I	-
P3	S3	S4	920.36	921.39	206.1	203.1	0.50%	15"	TYPE I	-
P4	S4	S5	921.635	921.94	62.8	59.7	0.50%	12"	TYPE I	-
P5	S5	S6	921.94	922.30	75.2	72.2	0.50%	12"	TYPE I	-
P6	S6	S7	922.30	922.48	38.8	36.2	0.50%	12"	TYPE I	-
P7	S2	S2-A	921.99	923.19	29.6	27.2	4.41%	12"	TYPE I	PIPE OVER HP GAS
P8	S3	S3-A	922.98	924.30	28.7	26.2	5.04%	12"	TYPE I	PIPE OVER HP GAS
P9	S4	S4-A	924.91	925.45	28.5	25.8	2.07%	12"	TYPE I	PIPE OVER HP GAS
P10	S5	S5-A	921.99	922.43	25.4	22.3	1.96%	12"	TYPE I	-
P11	S8	S9	915.00	922.78	119.2	117.9	6.60%	15"	TYPE I	-
P12	S9	S10	922.78	925.00	36.4	33.6	6.60%	15"	TYPE I	-
P13	S10	S11	925.00	925.58	77.1	74.1	0.78%	15"	TYPE I	PIPE OVER HP GAS
P14	S11	S12	925.83	925.92	17.5	15.5	0.60%	12"	TYPE I	-
P15	S12	S13	925.92	926.15	39.8	37.6	0.60%	12"	TYPE I	-
P16	S13	S14	926.15	926.24	17.5	15.5	0.60%	12"	TYPE I	-
P17	S10	S10-A	925.25	925.54	17.5	15.0	1.93%	12"	TYPE I	PIPE OVER HP GAS
P18	S15	S16	911.00	919.00	140.0	140.0	5.71%	60"	TYPE I	[5]; [8]; PIPE UNDER HP GAS
<b>FELLAND ROAD CHANNEL</b>										
P19	-	-	911.00	911.20	15.0	15.0	1.33%	10"	SDR-26	RELIEF DRAINAGE

## SPECIFIC NOTES:

- [1] INSTALL 15" RCP AE AND GATE AT PIPE OUTFALL
- [2] SEE SDD 5.5.1 A & B
- [3] INSTALL RAILING ALONG OR BEHIND HEADER AND WINGWALLS (BID ITEM 90031), SEE SDD 5.5.3
- [4] INCLUDE CUTOFF WALL AT THIS AE, PER SDD 5.4.4
- [5] INSTALL PIPE TIES, PER SDD 5.4.6
- [6] DS AE AND 12' OF PIPE TO BE ABANDONED IN PLACE
- [7] PLUG ENDS OF PIPE TO ABANDON IN PLACE
- [8] USE CAUTION WHEN EXCAVATING AND INSTALLING THIS PIPE; IF HP GAS MAIN NEEDS TO BE SUPPORTED DURING CONSTRUCTION, COORDINATE WITH ROGER AHLES OF MG&E (RAHLES@MGE.COM OR 608-252-5682)
- [9] UTILITY TO BE RELOCATED BY OWNER

## STANDARD NOTES:

- PLAN LENGTH (PAY LENGTH) IS FROM CENTER OF STRUCTURE TO CENTER OF STRUCTURE. PIPE LENGTH IS ACTUAL LENGTH OF PIPE FROM STRUCTURE WALL TO STRUCTURE WALL. SLOPE CALCULATED USING PIPE LENGTH.
- ABBREVIATIONS: AE = APRON ENDWALL; RCP = REINFORCED CONCRETE PIPE; HERCP = HORIZONTAL ELLIPTICAL REINFORCED CONCRETE PIPE; DNA = DOES NOT APPLY; SAS = SEWER ACCESS STRUCTURE; LP = LOW POINT INLET STRUCTURE; FP = FIELD POURED STRUCTURE; TR = TOP OF CONCRETE ROOF; NCM = NO CROWN MATCH FOR PIPES; UD = UNDERDRAIN
- APPROXIMATE DISCHARGE E.I. GIVEN, ADJUST E.I. AND PIPE SLOPE IN THE FIELD.
  - TOP OF CASTING GRADE GIVEN IS THE TOP OF CURB FOR INLET STRUCTURES AND THE FLOWLINE OF THE CLOSED CASTING FOR
- ALL REINFORCED CONCRETE PIPES TO BE CLASS III UNLESS OTHERWISE NOTED.
- SURVEYOR TO CONFIRM THAT ALL INLET STATION / OFFSETS LINE UP WITH PROPOSED CURB AND GUTTER.

- ALL FIELD POURED SAS STORM STRUCTURES SHALL BE CONSTRUCTED IN ACCORDANCE WITH THE NEW STANDARD DETAIL DRAWING FOR 5.7.3. ALL PRECAST SAS STORM STRUCTURES SHALL BE CONSTRUCTED IN ACCORDANCE WITH STANDARD DETAIL DRAWING 5.7.5.
- ALL STRUCTURES CALLED OUT AS FIELD POURED SHALL BE FIELD POURED. ALL OTHER STRUCTURES (NOT INDICATED AS FIELD POURED) SHALL BE SUBMITTED TO CITY ENGINEERING FOR APPROVAL IF PRECAST STRUCTURES ARE PREFERRED. CONTACT MATT ALLIE OF CITY ENGINEERING AT (608) 266-4058 FOR PRECAST APPROVALS, FAX SHOP DRAWINGS TO (608) 264-9275, OR EMAIL SHOP DRAWINGS TO MALLIE@CITYOFMADISON.COM.



# STORM SEWER SCHEDULE

\* REVISED 6/21/21 MAA - ULO#1-#4 REMOVED

FELLAND ROAD PROJECT NO. 13270	SHEET NO. U-7
STORM SEWER SCHEDULE	
CITY OF MADISON	

## REMOVE STORM STRUCTURES

STRUC. NO.	STATION	LOCATION (OFFSET)	TYPE	ID NO.
<b>FELLAND ROAD</b>				
R1	114+30.53	RT-25.4	60" RC AE	-

## REMOVE STORM PIPES

PIPE NO.	FROM (DISCH.)	TO (INLET)	PIPE LGTH (FT)	PAID (Y/N)	PAY LGTH (FT)	PIPE SIZE	PIPE TYPE	NOTES
<b>FELLAND ROAD</b>								
RP1	-	-	42.0	Y	42.0	24"	CMP	SEE SHEET U-2
RP2	-	R1	46.0	Y	17.0	60"	RCP	[6]; [8]; PIPE UNDER HP GAS; SEE SHEET U-1
RP3	-	-	34.0	Y	34.0	15"	CMP	SEE SHEET U-1

## EXISTING UTILITY LINE OPENINGS (ULOs)

ULO NO.	STATION	LOCATION (OFFSET)	TYPE	TOP ELEV.
GAS ULO 01	114+00.42	RT-5.3	HP GAS (8")	925.71
GAS ULO 02	114+50.44	RT-10.5	HP GAS (8")	924.82
GAS ULO 03	115+00.79	RT-17.5	HP GAS (8")	923.47
GAS ULO 04	115+50.60	RT-21.9	HP GAS (8")	923.13
GAS ULO 05	116+00.41	RT-16.0	HP GAS (8")	922.81
GAS ULO 06	116+50.46	RT-8.5	HP GAS (8")	923.20
GAS ULO 07	117+07.13	CL	HP GAS (8")	923.00
GAS ULO 08	117+49.94	LT-5.2	HP GAS (8")	922.99
GAS ULO 09	117+99.97	LT-1.0	HP GAS (8")	923.32
GAS ULO 10	118+50.06	RT-4.3	HP GAS (8")	923.03
GAS ULO 11	119+00.33	RT-8.1	HP GAS (8")	923.09
GAS ULO 12	119+50.42	RT-8.4	HP GAS (8")	923.09
GAS ULO 13	120+00.26	RT-9.2	HP GAS (8")	922.22
GAS ULO 14	120+50.36	RT-10.2	HP GAS (8")	921.77
GAS ULO 15	121+00.34	RT-11.1	HP GAS (8")	921.56
GAS ULO 16	121+50.28	RT-11.3	HP GAS (8")	921.44
GAS ULO 17	122+00.64	RT-11.1	HP GAS (8")	921.13
GAS ULO 18	122+50.37	RT-10.6	HP GAS (8")	920.98
GAS ULO 19	123+00.27	RT-10.5	HP GAS (8")	920.68
GAS ULO 20	123+49.85	RT-10.1	HP GAS (8")	920.68

## ABANDON STORM PIPES

FROM (DISCH.)	TO (INLET)	PIPE LGTH (FT)	PIPE SIZE	PIPE TYPE	NOTES
<b>FELLAND ROAD</b>					
AE EX	-	12.0	60"	RCP	[7]

## SPECIFIC NOTES:

- [1] INSTALL 15" RCP AE AND GATE AT PIPE OUTFALL
- [2] SEE SDD 5.5.1 A & B
- [3] INSTALL RAILING ALONG OR BEHIND HEADER AND WINGWALLS (BID ITEM 90031), SEE SDD 5.5.3
- [4] INCLUDE CUTOFF WALL AT THIS AE, PER SDD 5.4.4
- [5] INSTALL PIPE TIES, PER SDD 5.4.6
- [6] DS AE AND 12' OF PIPE TO BE ABANDONED IN PLACE
- [7] PLUG ENDS OF PIPE TO ABANDON IN PLACE
- [8] USE CAUTION WHEN EXCAVATING AND INSTALLING THIS PIPE; IF HP GAS MAIN NEEDS TO BE SUPPORTED DURING CONSTRUCTION, COORDINATE WITH ROGER AHLES OF MG&E (RAHLES@MGE.COM OR 608-252-5682)
- [9] UTILITY TO BE RELOCATED BY OWNER

## STANDARD NOTES:

- PLAN LENGTH (PAY LENGTH) IS FROM CENTER OF STRUCTURE TO CENTER OF STRUCTURE. PIPE LENGTH IS ACTUAL LENGTH OF PIPE FROM STRUCTURE WALL TO STRUCTURE WALL. SLOPE CALCULATED USING PIPE LENGTH.
- ABBREVIATIONS: AE = APRON ENDWALL; RCP = REINFORCED CONCRETE PIPE; HERCP = HORIZONTAL ELLIPTICAL REINFORCED CONCRETE PIPE; DNA = DOES NOT APPLY; SAS = SEWER ACCESS STRUCTURE; LP = LOW POINT INLET STRUCTURE; FP = FIELD POURED STRUCTURE; TR = TOP OF CONCRETE ROOF; NCM = NO CROWN MATCH FOR PIPES; UD = UNDERDRAIN
- APPROXIMATE DISCHARGE E.I. GIVEN, ADJUST E.I. AND PIPE SLOPE IN THE FIELD.
  - TOP OF CASTING GRADE GIVEN IS THE TOP OF CURB FOR INLET STRUCTURES AND THE FLOWLINE OF THE CLOSED CASTING FOR
- ALL REINFORCED CONCRETE PIPES TO BE CLASS III UNLESS OTHERWISE NOTED.
- SURVEYOR TO CONFIRM THAT ALL INLET STATION / OFFSETS LINE UP WITH PROPOSED CURB AND GUTTER.

- ALL FIELD POURED SAS STORM STRUCTURES SHALL BE CONSTRUCTED IN ACCORDANCE WITH THE NEW STANDARD DETAIL DRAWING FOR 5.7.3. ALL PRECAST SAS STORM STRUCTURES SHALL BE CONSTRUCTED IN ACCORDANCE WITH STANDARD DETAIL DRAWING 5.7.5.
- ALL STRUCTURES CALLED OUT AS FIELD POURED SHALL BE FIELD POURED. ALL OTHER STRUCTURES (NOT INDICATED AS FIELD POURED) SHALL BE SUBMITTED TO CITY ENGINEERING FOR APPROVAL IF PRECAST STRUCTURES ARE PREFERRED. CONTACT MATT ALLIE OF CITY ENGINEERING AT (608) 266-4058 FOR PRECAST APPROVALS, FAX SHOP DRAWINGS TO (608) 264-9275, OR EMAIL SHOP DRAWINGS TO MALLIE@CITYOFMADISON.COM.

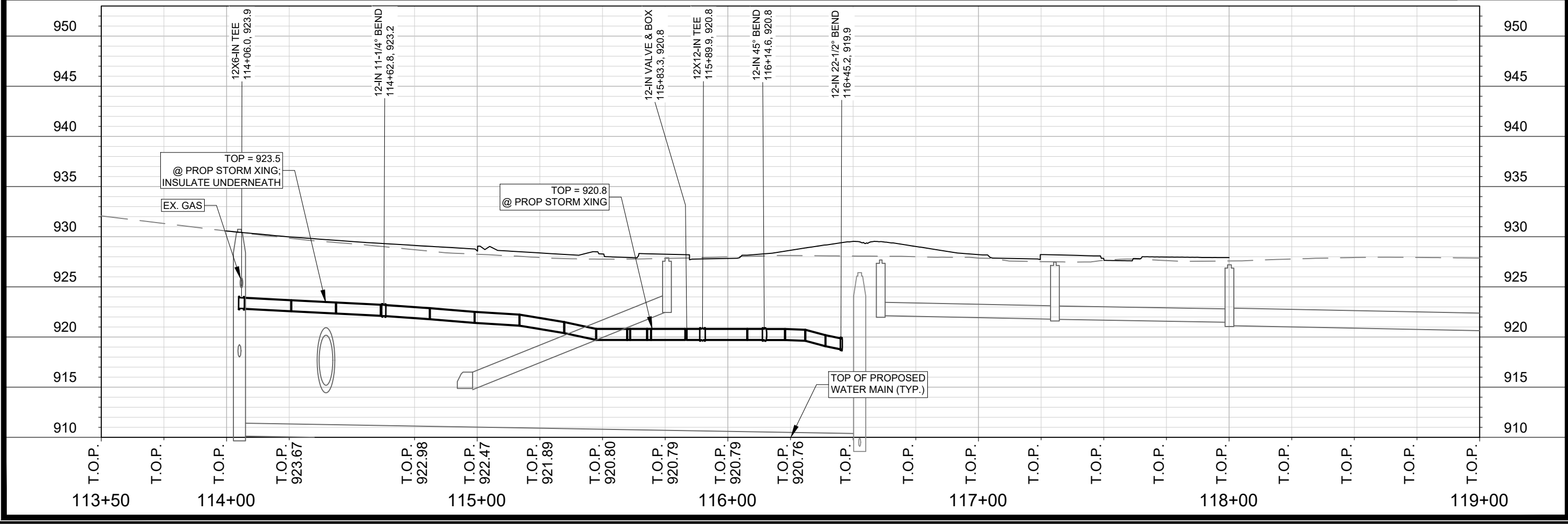
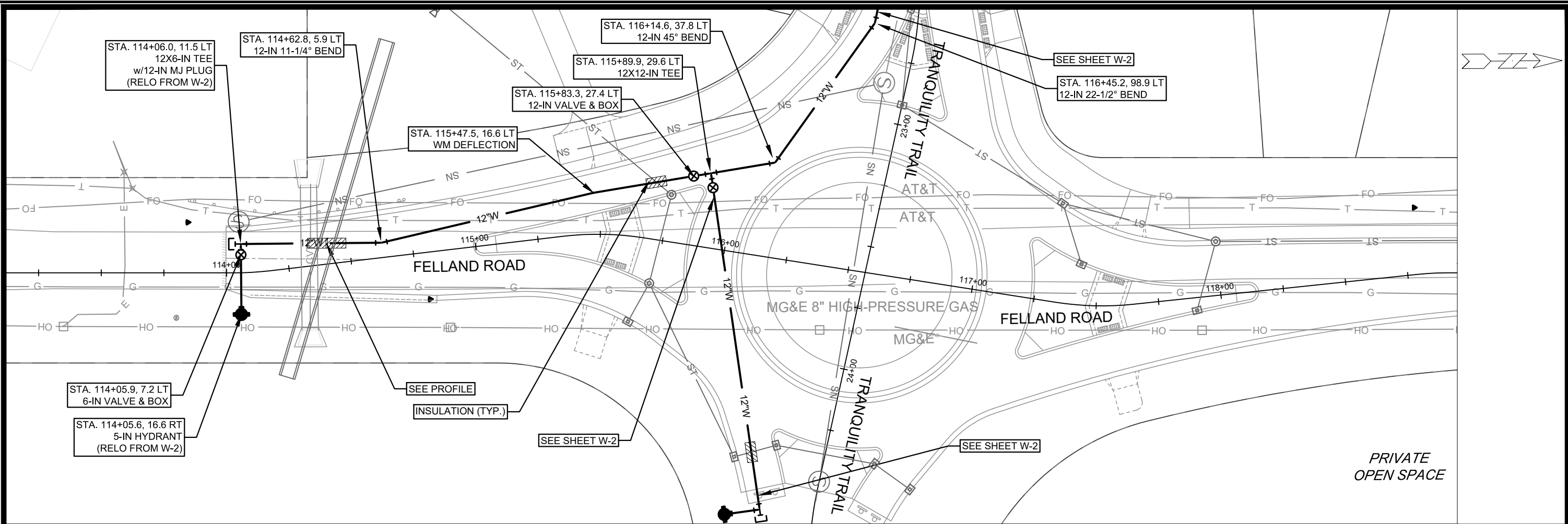

MARK	REVISION	DATE	BY
13270		5/14/2021 7:45 AM	W-1

13270  
 MADISON, WI  
 8564  
 CONTRACT NO.:  
 WATER PLAN & PROFILE - FELLAND ROAD  
 FELLAND ROAD & TRANQUILITY TRAIL ROUNDABOUT  
 M:\DESIGN\Projects\13303\CAD\Water\13270\WU-Water.dwg  
  
 13270  
 W-1

PROPOSED WATER MAIN -  
VILLAGE AT AUTUMN LAKE PHASE 11  
PROJECT NO. 13303 (2021)

STA. 22+60.7, 17.0 RT  
12-IN 22-1/2° BEND

STA. 22+15.7, 12.5 RT  
CONNECT TO EX 12-IN WM  
RELOCATE EX 12X6-IN TEE  
RELOCATE EX 12-IN MJ PLUG  
RELOCATE EX HYDRANT

STA. 23+25.4, 44.5 RT  
12-IN 45° BEND

STA. 23+35.0, 68.6 RT  
12X12-IN TEE  
SEE SHEET W-1

STA. 23+40.5, 66.5 RT  
12-IN VALVE & BOX

STA. 24+60.1, 21.3 RT  
12X6-IN TEE  
w/12-IN MJ PLUG

STA. 24+63.0, 35.1 RT  
5-IN HYDRANT

INSULATION (TYP.)

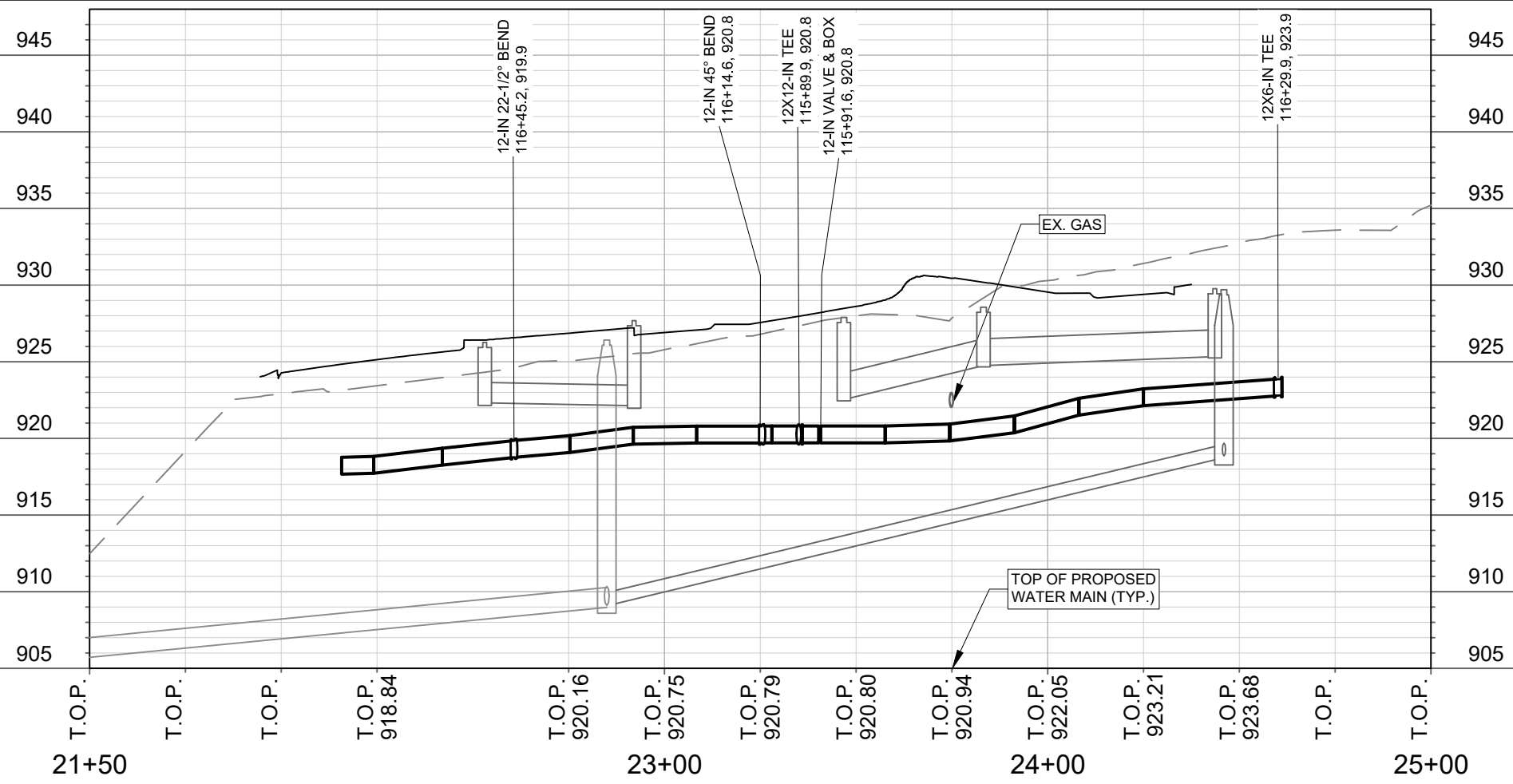
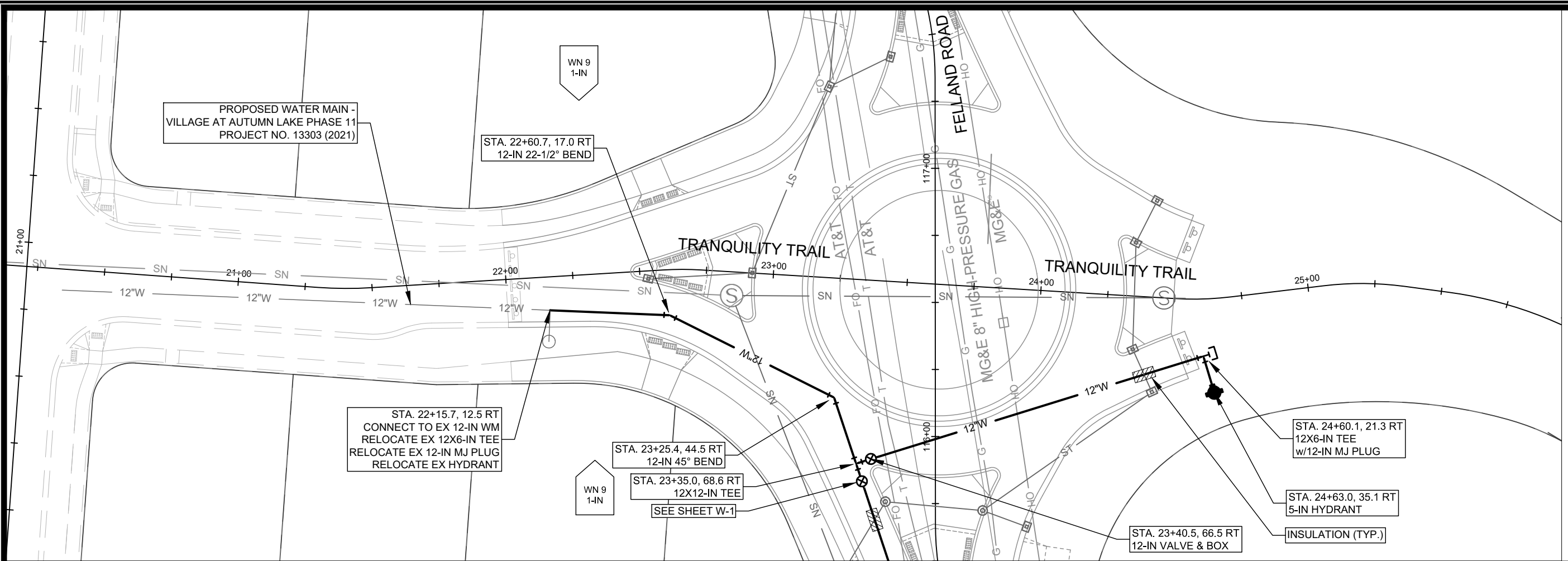

MARK	REVISION	DATE	BY
13270	5/14/2021 7:45 AM	1" = 40'	W-2

13270  
MADISON, WI  
CONTRACT NO: 8564

WATER PLAN & PROFILE - TRANQUILITY TRAIL  
FELLAND ROAD & TRANQUILITY TRAIL ROUNDABOUT  
M:\DESIGN\Projects\13303\CAD\Water\13270WU-Water.dwg



13270  
W-2



**CONSTRUCTION NOTES:**

1. CONSTRUCT NEW WATER MAIN BELOW FINISHED GRADE AS NOTED IN THE PROFILES. INSULATE MAIN WITH POLYSTYRENE BOARD AT UTILITY CROSSINGS OR OTHER AREAS IDENTIFIED BY THE ENGINEER AS HAVING INADEQUATE COVER.
2. MINIMIZE DISRUPTIONS OF SERVICE TO EXISTING WATER CUSTOMERS. NOTIFY PER STANDARD SPECIFICATION REQUIREMENTS OF ANY PLANNED WATER OUTAGE.
3. THE EXISTING UTILITIES SHOWN ON THESE PLANS REPRESENT THE BEST INFORMATION AVAILABLE TO THE WATER UTILITY AT THE TIME OF PLAN REPARATION. THE CONTRACTOR IS RESPONSIBLE OR HAVING EACH UTILITY LOCATED AND MARKED PRIOR TO COMMENCING WORK.

- WN1 REPLACE THE EXISTING LEAD SERVICE WITH A NEW COPPER SERVICE.
- WN-2 EXTEND AND RECONNECT THE EXISTING COPPER SERVICE TO THE NEW WATER MAIN.
- WN-3 EXISTING SERVICE TO BE ABANDONED WHEN THE WATER MAIN IS CUT OFF.
- WN-4 DISCONNECT FROM THE OLD WATER MAIN AND RECONNECT THE EXISTING COPPER WATER SERVICE LATERAL TO THE NEW WATER MAIN.
- WN-5 RELOCATE THE EXISTING FIRE HYDRANT.
- WN-6 ABANDON WATER VALVE ACCESS STRUCTURE.
- WN-7 FURNISH AND INSTALL THE NEW TOP SECTION FOR THE WATER ACCESS STRUCTURE.
- WN-8 ABANDON THE VALVE BOX.
- WN-9 FURNISH THE DITCH, COMPACTION, AND ALL MATERIALS AND LABOR FOR THE INSTALLATION OF NEW SERVICE LATERAL.
- WN-10 REMOVE AND SALVAGE EXISTING HYDRANT
- WN-11 REPLACE THE EXISTING COPPER SERVICE WITH A COPPER SERVICE
- WN-20+ SEE WATER IMPACT PLAN FOR CONNECTION POINT ISOLATION AND WATER SHUT-OFF NOTIFICATION INFORMATION.

ULO	UTILITY	STATION	OFFSET	SHEET
N/A				

**ESTIMATE OF NEW MATERIALS\***

DESCRIPTION	QUANTITY	UNIT
6-INCH PIPE	40	LNFT
12-INCH PIPE	460	LNFT
6-INCH WATER VALVE	1	EACH
12-INCH WATER VALVE	2	EACH
5-IN HYDRANT	1	EACH
1-INCH SERVICE LATERALS	2	EACH
STYROFOAM INSULATION BOARDS	4	EACH
12-IN 45° BEND	1	EACH
12-IN 22-1/2° BEND	1	EACH
12-IN 11-1/4° BEND	1	EACH
12X6-IN REDUCER	1	EACH
12X6-IN TEE	1	EACH
12X12-IN TEE	1	EACH
12-IN MJ PLUG	1	EACH

**ESTIMATE OF REUSED AND SALVAGED MATERIALS\***

DESCRIPTION	QUANTITY	TYPE
5-IN HYDRANT	1	REUSE
12X6-IN TEE	1	REUSE
12-IN MJ PLUG	1	REUSE

\* ESTIMATES OF MATERIALS ARE FOR INFORMATION ONLY. ENGINEER DOES NOT GUARANTEE ACCURACY OF MATERIAL TAKE-OFF.

TO OBTAIN LOCATION OF PARTICIPANTS' UNDERGROUND FACILITIES BEFORE YOU DIG IN WISCONSIN  
 CALL DIGGERS HOTLINE TOLL FREE  
 811 OR 1-800-242-8511  
 FAX-A-LOCATE 1-800-338-3860  
 TDD (FOR HEARING IMPAIRED) 1-800-542-2289

WIS. STATUTE 182.0175 (1974) REQUIRES MIN. OF 3 WORK DAYS NOTICE BEFORE YOU EXCAVATE.

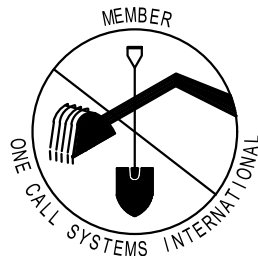

DISCLAIMER NOTE: UTILITY LOCATIONS SHOWN ARE APPROXIMATE ONLY. IT SHALL BE THE CONTRACTOR'S RESPONSIBILITY TO DETERMINE THE EXACT HORIZONTAL AND VERTICAL LOCATION OF ALL EXISTING UNDERGROUND AND OVERHEAD UTILITIES PRIOR TO COMMENCING WORK.

**PART VII - WATER MAINS AND SERVICE LATERALS**

**DETAIL DRAWING NO. 7.04**  
 REVISED: 12/2019

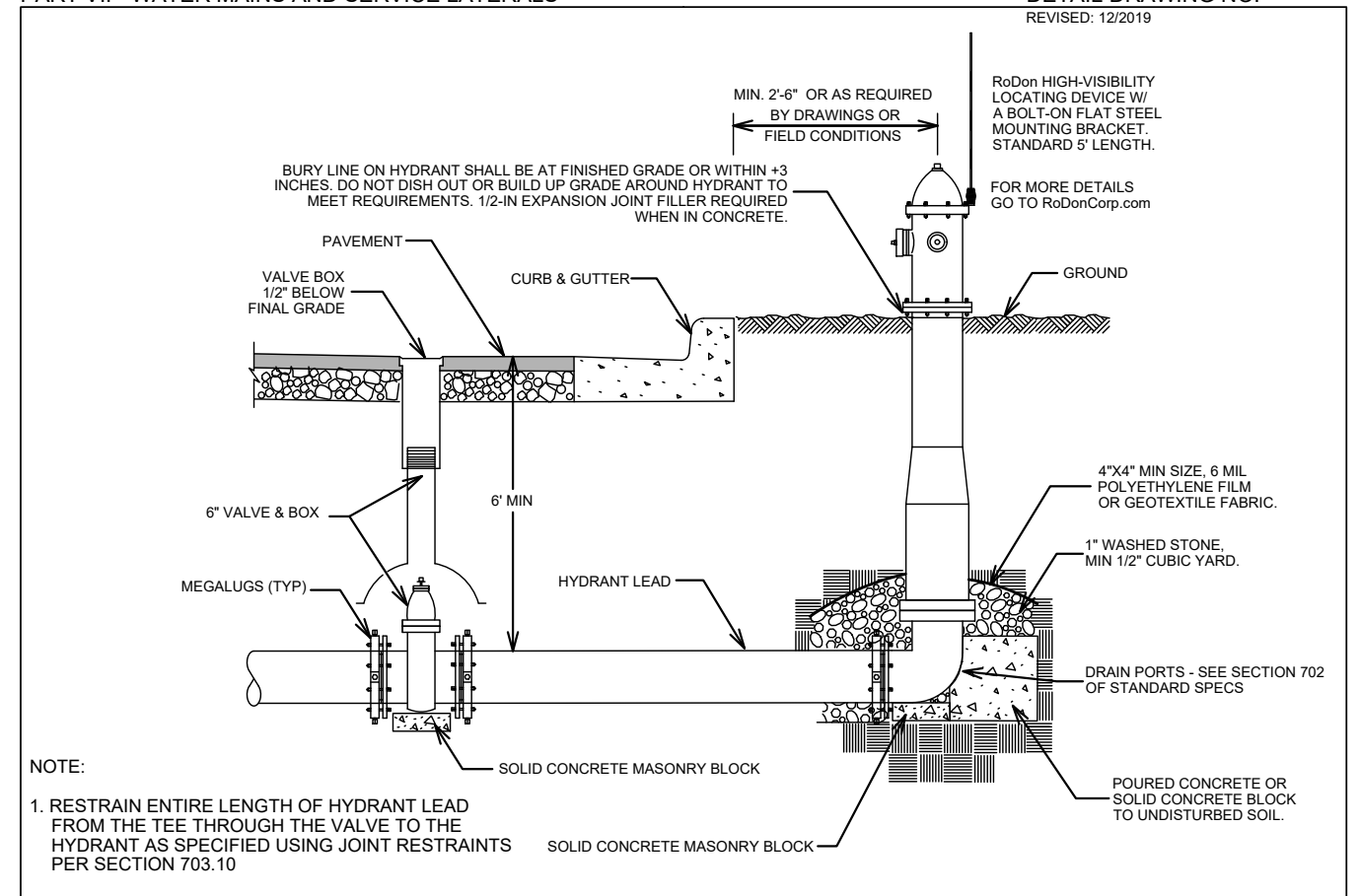

**NOTE:**

1. RESTRAIN ENTIRE LENGTH OF HYDRANT LEAD FROM THE TEE THROUGH THE VALVE TO THE HYDRANT AS SPECIFIED USING JOINT RESTRAINTS PER SECTION 703.10

CITY OF MADISON WATER UTILITY

NOT TO SCALE

TYPICAL HYDRANT INSTALLATION

FELLAND ROAD & TRANQUILITY TRAIL ROUNDABOUT

WATER ESTIMATE OF MATERIALS

CITY OF MADISON, WISCONSIN

SCALE: N/A

DESIGNED BY: PEH

MADISON WATER UTILITY

119 E OLIN AVE, MADISON, WI 53713

PRINTING DATE: 5/14/21

CONTRACT NO: 8564





13270

W-3

GENERAL ELECTRICAL NOTES:

1. ALL LOCATIONS ARE APPROXIMATE, THE TRAFFIC ENGINEER SHALL APPROVE FINAL LOCATIONS, INCLUDING SETBACK, IN THE FIELD AFTER CONTRACTOR SURVEYS STAKING. THE CONTRACTOR SHALL NOTIFY JERRY SCHIPPA, (267-1969), CITY TRAFFIC ENGINEERING, AT LEAST 24-HOURS IN ADVANCE OF NEEDING CONDUIT OR BASE LOCATIONS MARKED.
2. THE CONTRACTOR SHALL DO ALL WORK IN ACCORDANCE WITH "CITY OF MADISON STANDARD SPECIFICATIONS FOR PUBLIC WORKS CONSTRUCTION, 2021 EDITION" AND ALL ADDENDUMS THERETO.
3. ALL CONDUITS SHALL BE PVC, SCHEDULE 80 BENEATH PAVEMENT, OR SCHEDULE 40 OTHERWISE. PULL WIRE SHALL BE INSTALLED IN ALL CONDUITS PER STANDARD SPECIFICATIONS.
4. THE CONTRACTOR SHALL CALL MIKE BENZSCHAWEL AT (266-9031) AT THE TRAFFIC ENGINEERING SHOP AT LEAST 24-HOURS IN ADVANCE OF PLACING CONCRETE BASES, INSTALLING HANDHOLES, OR BURYING CONDUIT TO ARRANGE FOR INSPECTION.
5. ANY WORK COMPLETED WITHOUT INSPECTION IS SUBJECT TO REJECTION.
6. EXISTING STREETLIGHTS SHALL BE IN SERVICE EACH AND EVERY NIGHT.
7. ALL CONDUIT SIZES ON PLANS ARE 2-INCH UNLESS OTHERWISE NOTED (IN EVENT OF CONFLICT, DEFER TO MISC. QUANTITITES).
8. THE CONTRACTOR SHALL ARRANGE FOR PICKUP OF THE FOLLOWING CITY FURNISHED MATERIALS, WHICH SHOULD BE ARRANGED BY CALLING ED SMITH, TRAFFIC ENGINEERING SHOP (266-9034) AT LEAST 24-HOURS PRIOR TO NEEDING MATERIALS
  - 8.1. (44) 1-INCH x 40-INCH ANCHOR BOLTS FOR LB-3 BASES
  - 8.2. (8)  $\frac{3}{4}$  -INCH x 24-INCH ANCHOR BOLTS FOR LB-2 BASES

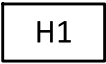
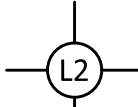
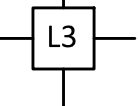
LEGEND

- FURNISH AND INSTALL PVC CONDUIT, 2-INCH UNLESS OTHERWISE NOTED
-  CONSTRUCT TYPE I HANDHOLE
-  CONSTRUCT TYPE LB-2 BASE
-  CONSTRUCT TYPE LB-3 BASE
-  CONSTRUCT TYPE P CONTROLLER BASE

ELECTRICAL PLANS	13270	MADISON, WI	8564	CONTRACT NO:	E-1
FELLAND RD & TRANQUILITY TRL ROUNDABOUT					
M:\DESIGN\Projects\13270\CAD\Traffic\13270TE-Lighting.v2.dwg					
					
13270					
E-1					



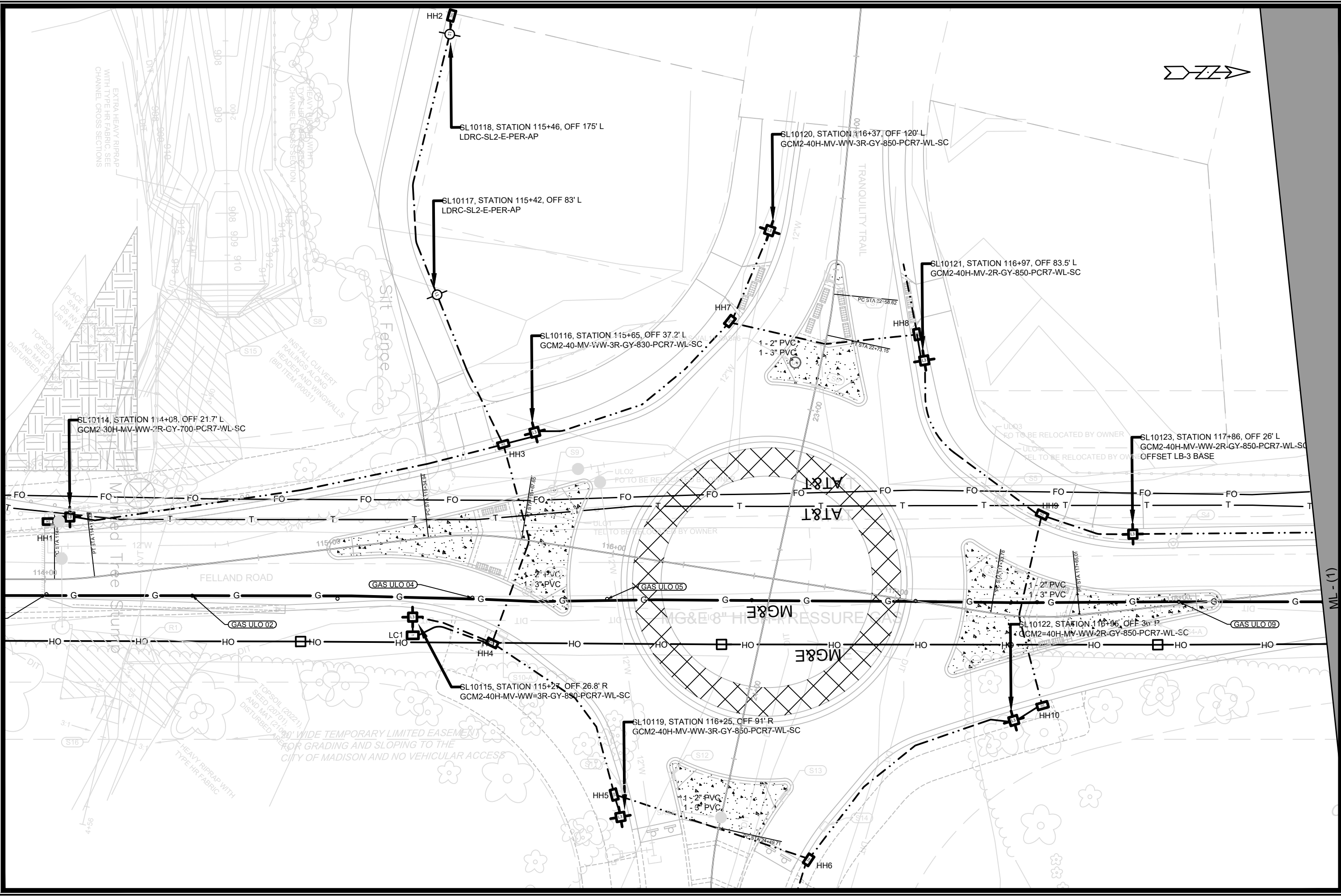

DATE	BY
REVISION	
MARK	
Designed By: JLS	Date: 5/10/2021
13270	E-2

13270  
 MADISON, WI  
 CONTRACT NO: 8564

ELECTRICAL PLANS  
 FELLAND ROAD & TRANQUILITY TRAIL ROUNDABOUT  
 M:\DESIGN\Projects\13270\CAD\Traffic\13270TE-Lighting.v2.dwg



13270  
 E-2

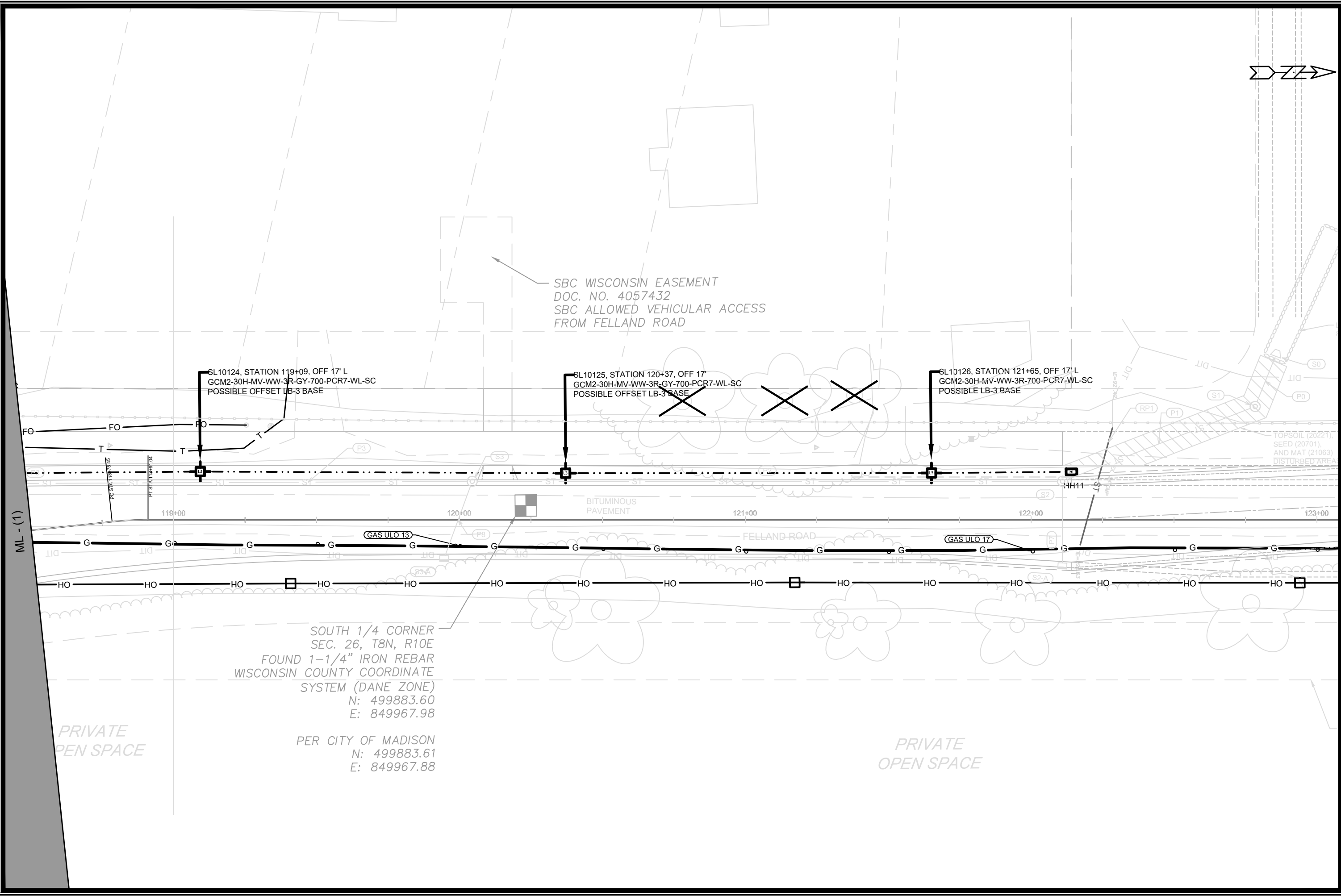

SBC WISCONSIN EASEMENT  
 DOC. NO. 4057432  
 SBC ALLOWED VEHICULAR ACCESS  
 FROM FELLAND ROAD

SL10124, STATION 119+09, OFF 17' L  
 GCM2-30H-MV-WW-3R-GY-700-PCR7-WL-SC  
 POSSIBLE OFFSET LB-3 BASE

SL10125, STATION 120+37, OFF 17'  
 GCM2-30H-MV-WW-3R-GY-700-PCR7-WL-SC  
 POSSIBLE OFFSET LB-3 BASE

SL10126, STATION 121+65, OFF 17' L  
 GCM2-30H-MV-WW-3R-700-PCR7-WL-SC  
 POSSIBLE LB-3 BASE

SOUTH 1/4 CORNER  
 SEC. 26, T8N, R10E  
 FOUND 1-1/4" IRON REBAR  
 WISCONSIN COUNTY COORDINATE  
 SYSTEM (DANE ZONE)  
 N: 499883.60  
 E: 849967.98

PER CITY OF MADISON  
 N: 499883.61  
 E: 849967.88

PRIVATE  
 OPEN SPACE

PRIVATE  
 OPEN SPACE

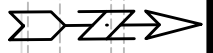

MARK	REVISION	DATE	BY
13270	5/10/2021		
Designed By: JLS		Scale: 1" = 30'	
13270		E-3	

13270  
 MADISON, WI  
 8564  
 CONTRACT NO:  
 ELECTRICAL PLANS  
 FELLAND ROAD & TRANQUILITY TRAIL ROUNDABOUT  
 M:\DESIGN\Projects\13270\CAD\Traffic\13270TE-Lighting.v2.dwg



13270  
 E-3

**13270 - STREET LIGHTING CONDUIT MISC. QUANTITIES**

FROM	TO	FURNISH & INSTALL			ELECTRICAL TRENCH	FURNISH & INSTALL 3 #4 AND 1 #8 WIRES IN EXISTING OR CONTRACTOR- INSTALLED CONDUIT	COMMENTS
		3-INCH	2-INCH				
		SCH 80 60222 L.F.	SCH 80 60230 L.F.	SCH 40 60232 L.F.			
HH1	SL10114	-	-	8	8	49	Additional 6' wire in HH, 35' in pole (typ)  Additional 20' wire in pole Additional 20' wire in pole
SL10114	HH3	-	-	160	160	166	
HH3	SL10117	-	-	56	56	76	
SL10117	SL10118	-	-	93	93	113	
SL10118	HH2	-	-	6	6	12	
HH3	HH4	71	71	-	71	77	
HH4	SL10115	-	-	32	32	67	
HH4	HH5	-	-	73	73	79	
HH5	SL10119	-	-	8	8	43	
HH5	HH6	72	72	-	72	78	
HH6	END	-	-	24	24	-	Cap end of conduit
HH6	SL10122	-	-	90	90	125	
SL10122	HH10	-	-	11	11	17	
HH10	HH9	70	70	-	70	76	
HH3	SL10116	-	-	12	12	47	
SL10116	HH7	-	-	86	86	92	Cap end of conduit
HH7	SL10120	-	-	32	32	67	
HH7	HH8	66	66	-	66	72	
HH8	END	-	-	23	23	-	
HH8	SL10121	-	-	11	11	46	
SL10121	HH9	-	-	73	73	79	
HH9	SL10123	-	-	33	33	68	
SL10123	SL10124	-	-	126	126	161	
SL10124	SL10125	-	-	127	127	162	
SL10125	SL10126	-	-	128	128	163	
SL10126	HH11	-	-	49	49	-	
LC1	HH4	-	-	30	10	36	
LC1	SL10115	-	-	6	6	12	

TOTALS      279                  279                  1297                  1556                  1983

DATE	BY
REVISION	
Date: 4/20/2021	
MARK	
Designed By: JLS	
13270	
E-4	

**13270**  
**MADISON, WI**  
**8564**  
**CONTRACT NO:**

**ELECTRICAL PLANS**  
**FELLAND RD & TRANQUILITY TRL ROUNDABOUT**  
M:\DESIGN\Projects\13270\CAD\Traffic\13270TE-Lighting.v2.dwg





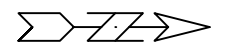
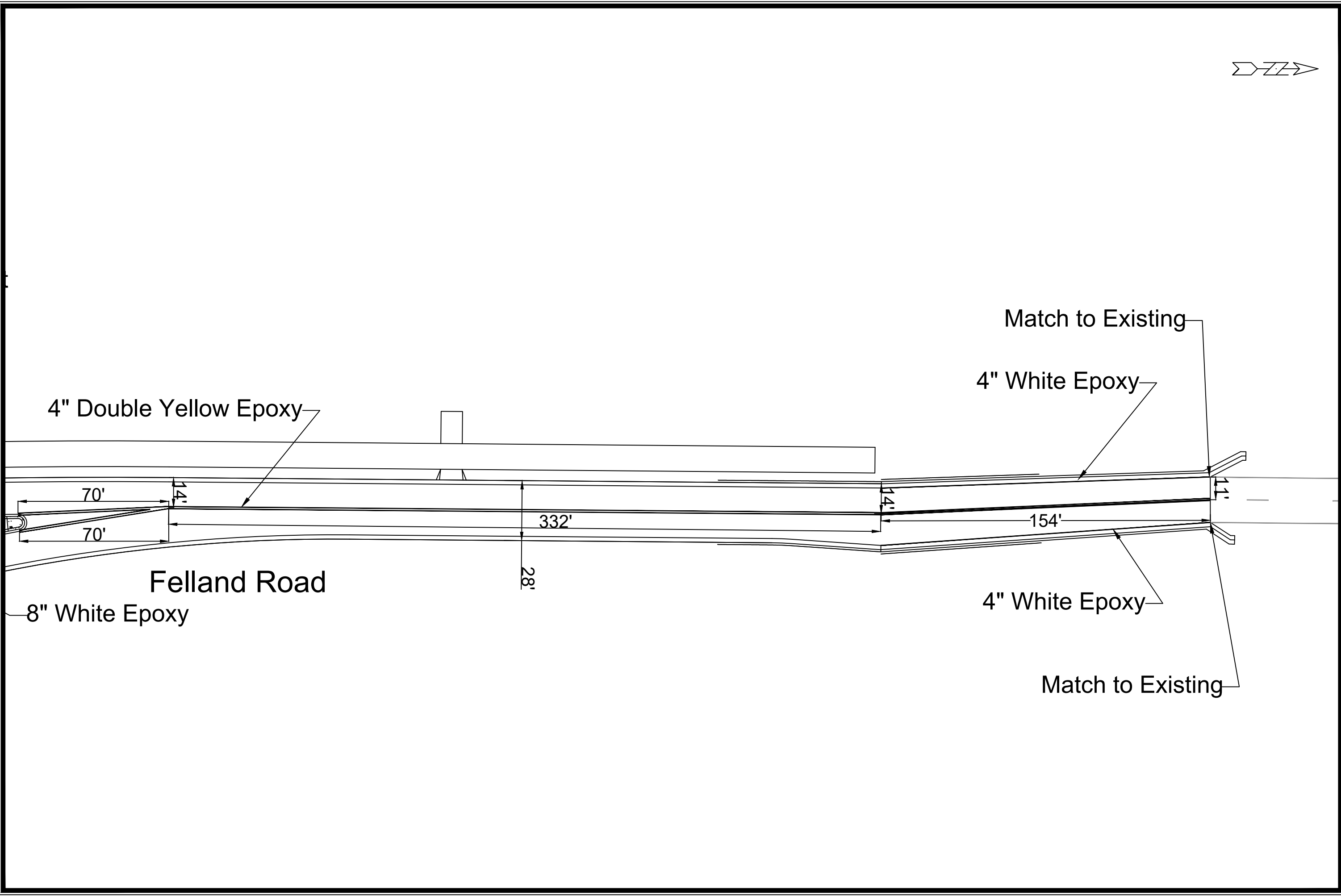

MARK	REVISION	DATE	BY
13270	5/11/2021 2:49 PM		M-2

MARKING PLAN  
 13270  
 MADISON, WI  
 FELLAND-TRANQUILITY ROUNDABOUT  
 M:\DESIGN\Projects\13270\CAD\Traffic\13270TE-PavementMarking.dwg  
 CONTRACT NO: ----



13270  
 M-2



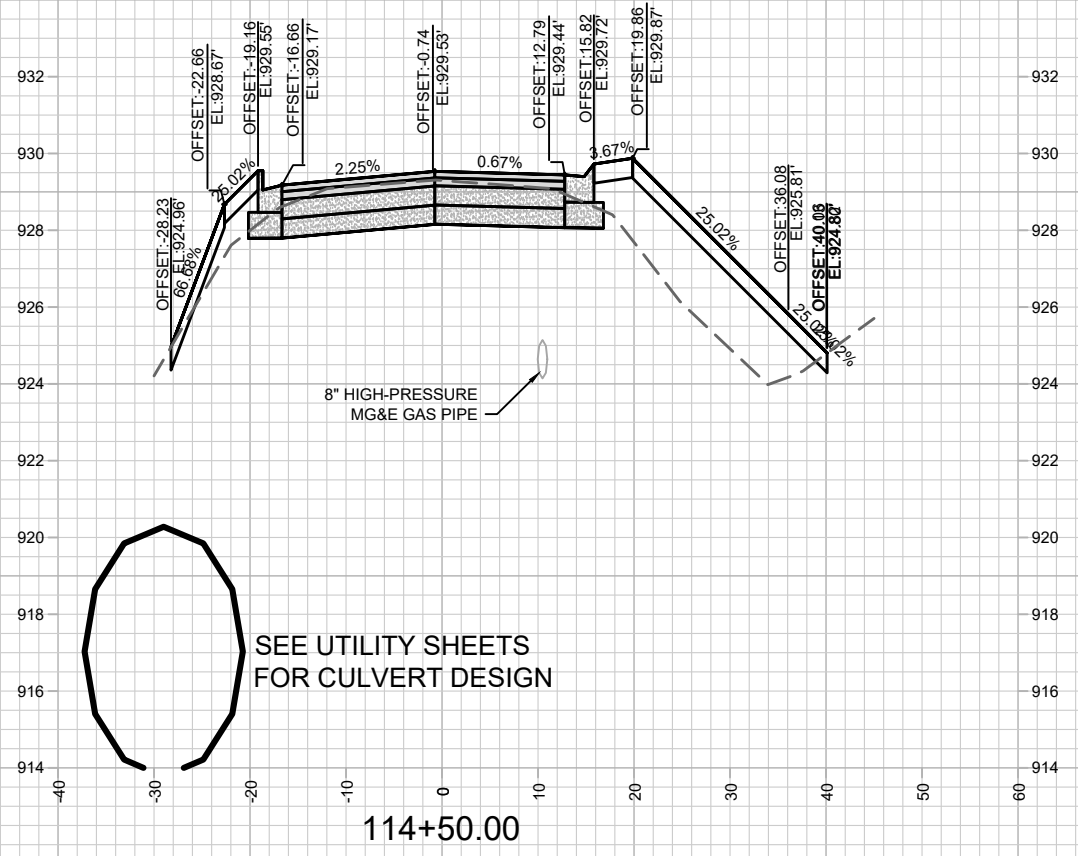
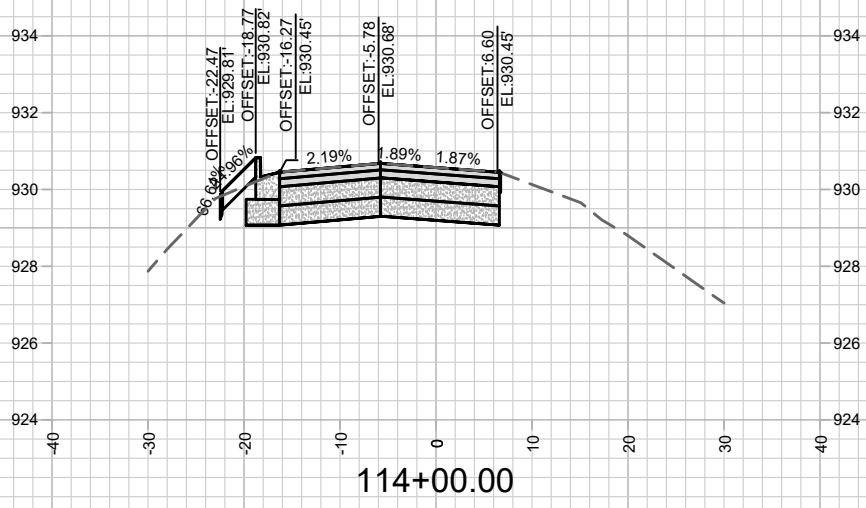
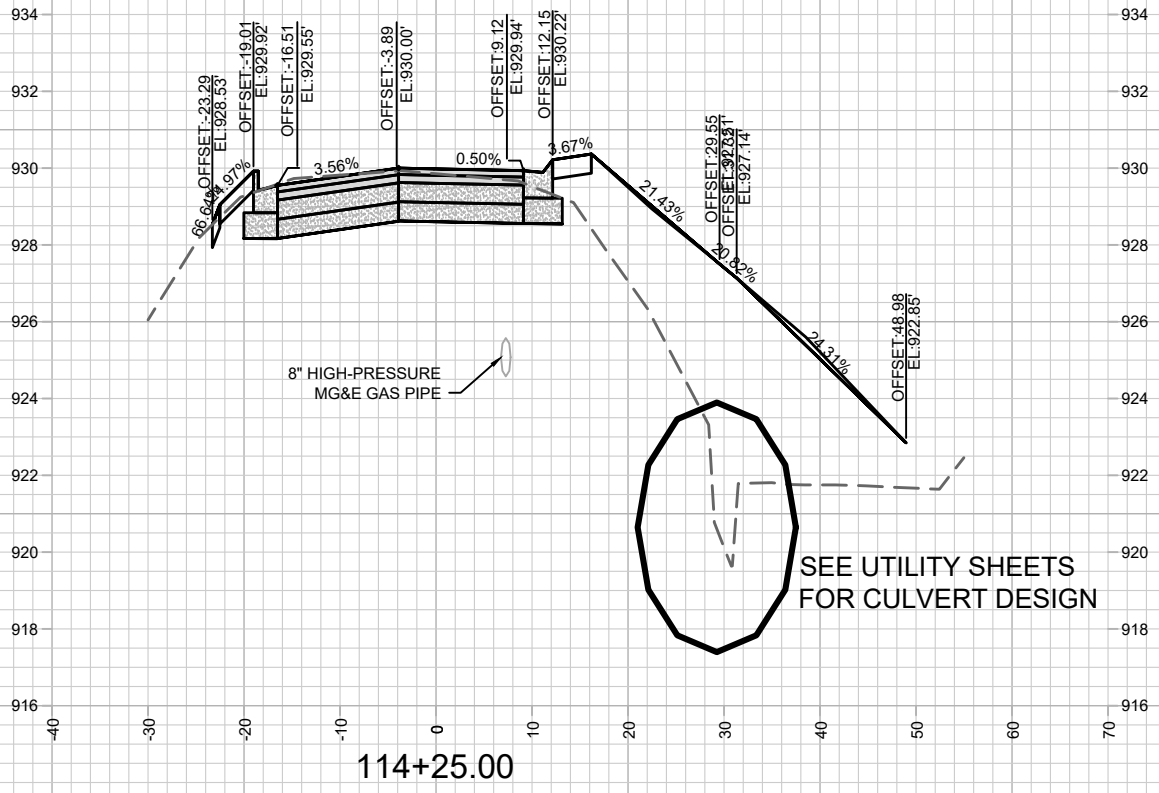

MARK	REVISION	DATE	BY
13270	5/11/2021 9:37 AM	###	###
Designed By: AJC	Scale: #####		X-1

**13270**  
**MADISON, WI**  
**8564**  
**CONTRACT NO:**  
 FELLAND ROAD - CROSS SECTIONS  
 FELLAND ROAD & TRANQUILITY TRAIL ROUNDABOUT  
 M:\DESIGN\Projects\13303\CAD\Streets\13270EN-FellandRABCorridor.dwg



**13270**  
**X-1**

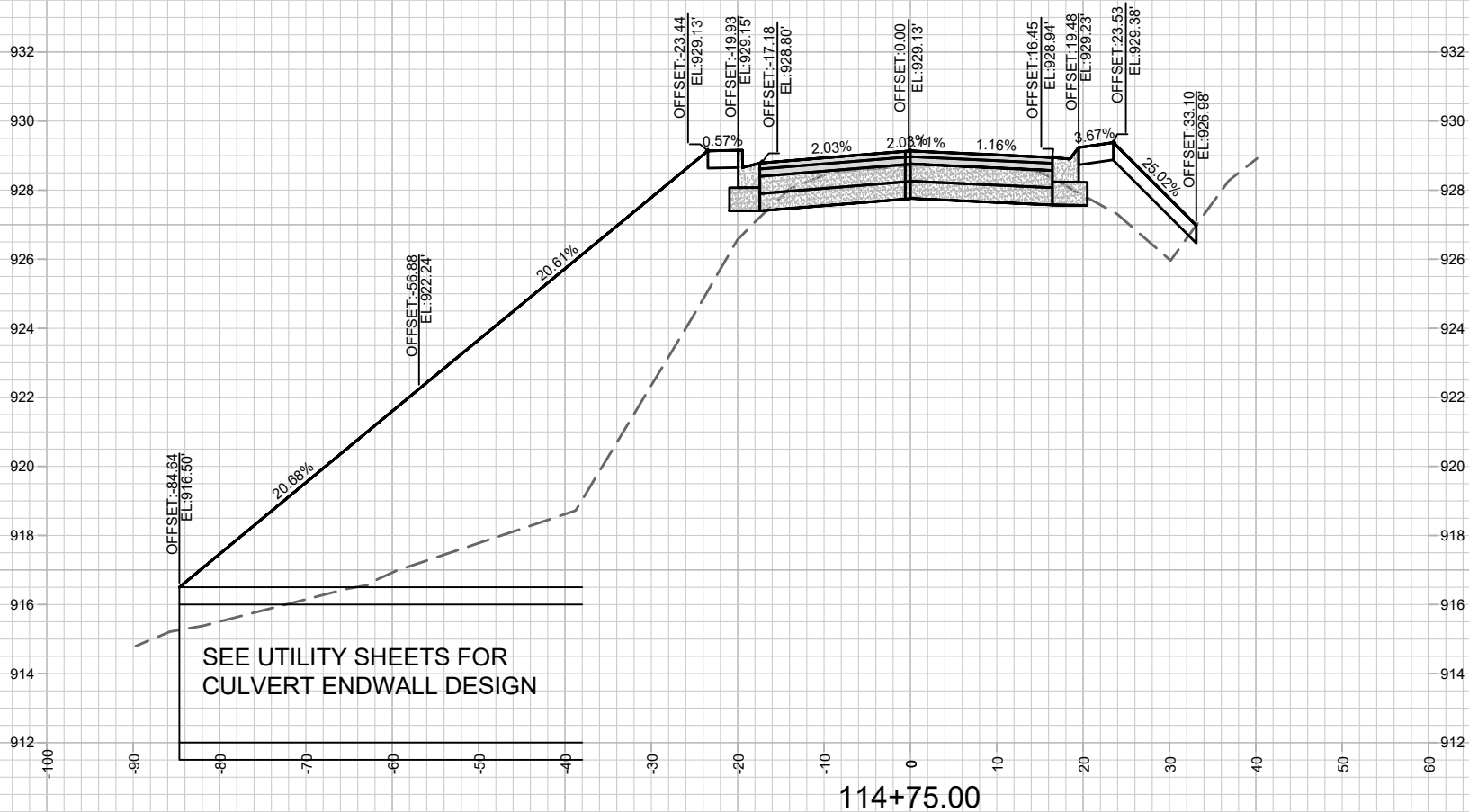

SEE UTILITY SHEETS FOR  
CULVERT ENDWALL DESIGN

MARK	REVISION	DATE	BY
13270	5/11/2021 9:37 AM	13270	X-2

FELLAND ROAD - CROSS SECTIONS  
 FELLAND ROAD & TRANQUILITY TRAIL ROUNDABOUT  
 13270  
 MADISON, WI  
 8564  
 CONTRACT NO:  
 M:\DESIGN\Projects\13303\CAD\Streets\13270EN-FellandRABCorridor.dwg



13270  
X-2

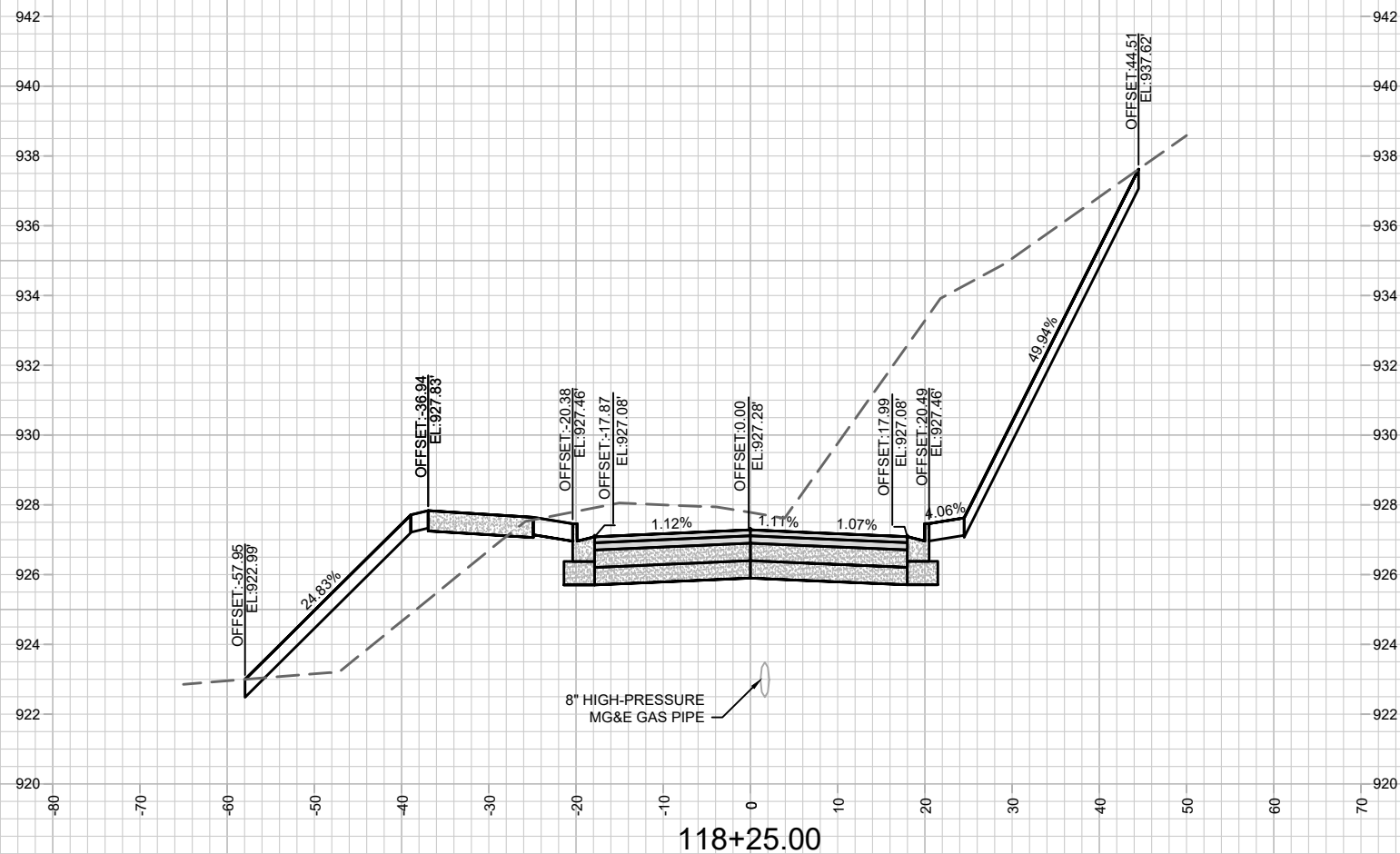

118+25.00

8" HIGH-PRESSURE  
MG&E GAS PIPE

MARK	REVISION	DATE	BY
13270	5/11/2021 9:37 AM	###	###
Designed By: AJC		Scale: #####	
13270		X-3	

FELLAND ROAD - CROSS SECTIONS  
 FELLAND ROAD & TRANQUILITY TRAIL ROUNDABOUT  
 MADISON, WI  
 CONTRACT NO: 8564  
 M:\DESIGN\Projects\13303\CAD\Streets\13270EN-FellandRABCorridor.dwg



13270  
X-3

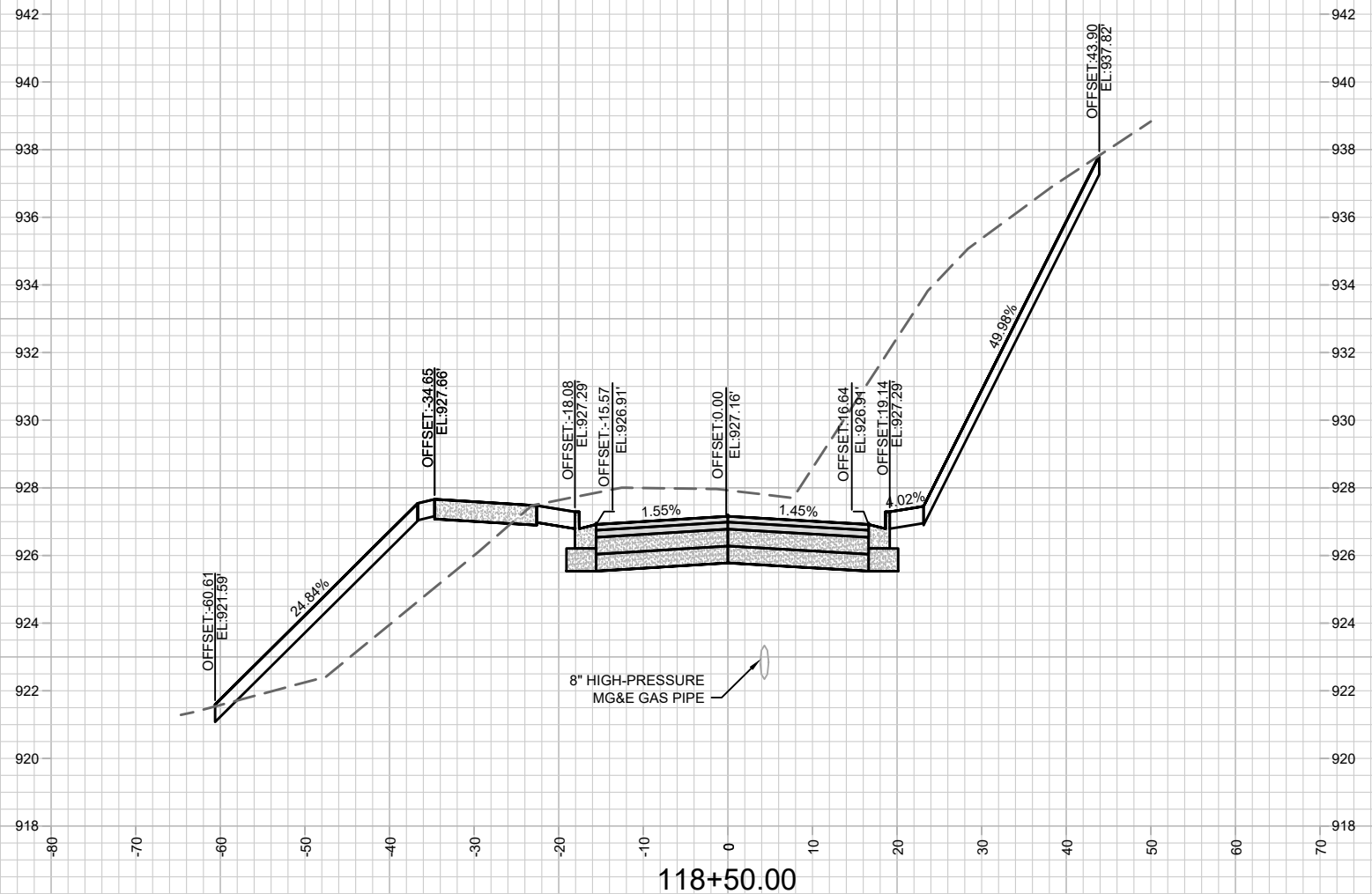

MARK	REVISION	DATE	BY
13270	Date: 5/11/2021 9:38 AM		X-4

13270  
 MADISON, WI  
 FELLAND ROAD - CROSS SECTIONS  
 FELLAND ROAD & TRANQUILITY TRAIL ROUNDABOUT  
 CONTRACT NO: 8564  
 M:\DESIGN\Projects\13303\CAD\Streets\13270\EN-FellandRABCorridor.dwg



13270  
 X-4

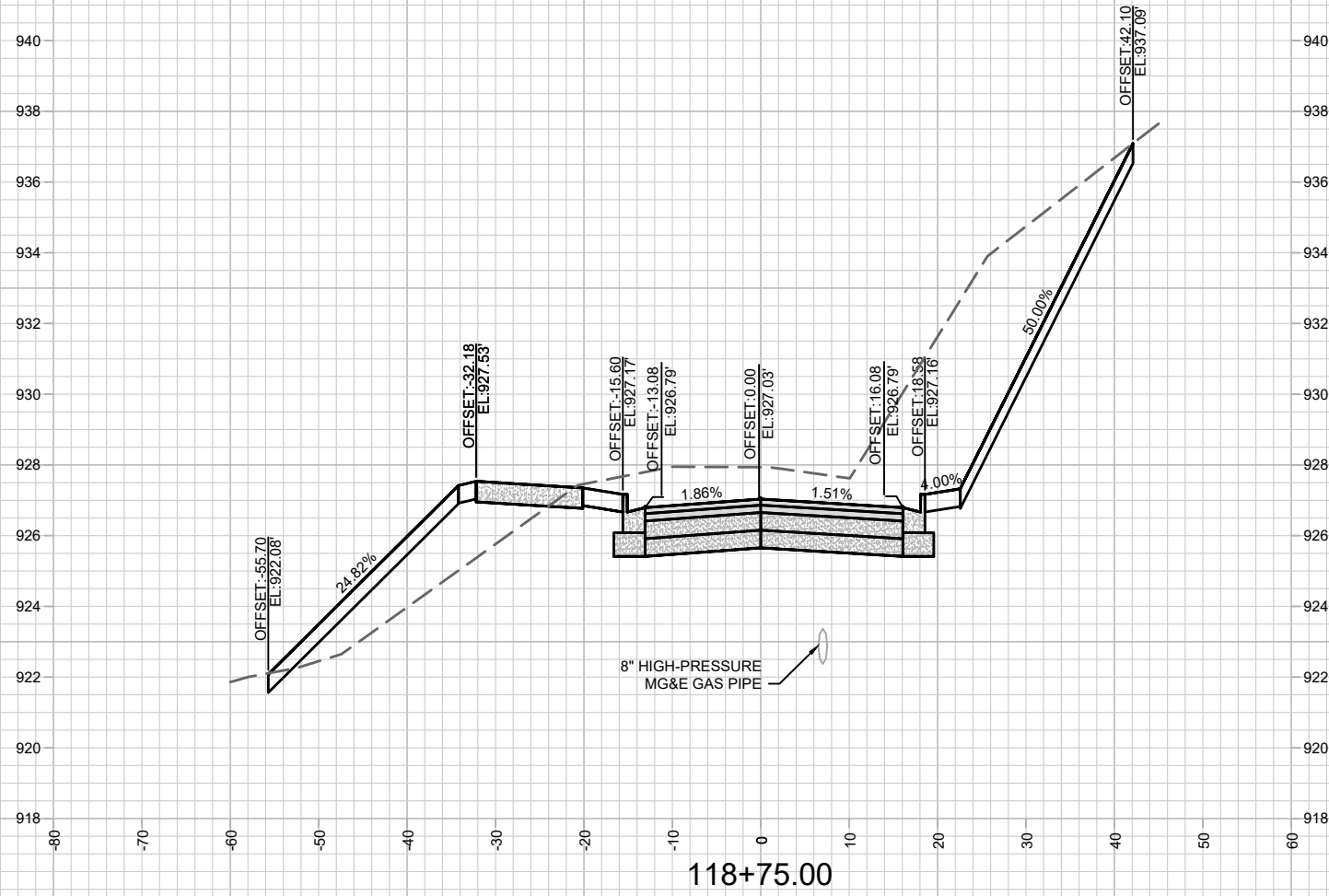

13270  
X-5

FELLAND ROAD - CROSS SECTIONS  
FELLAND ROAD & TRANQUILITY TRAIL ROUNDABOUT

M:\DESIGN\Projects\13303\CAD\Streets\13270\EN-FellandRABCorridor.dwg

13270  
MADISON, WI  
CONTRACT NO: 8564

MARK	REVISION	DATE	BY
13270	Designed By: AJC	Date: 5/11/2021 9:38 AM	Scale: #####
			X-5

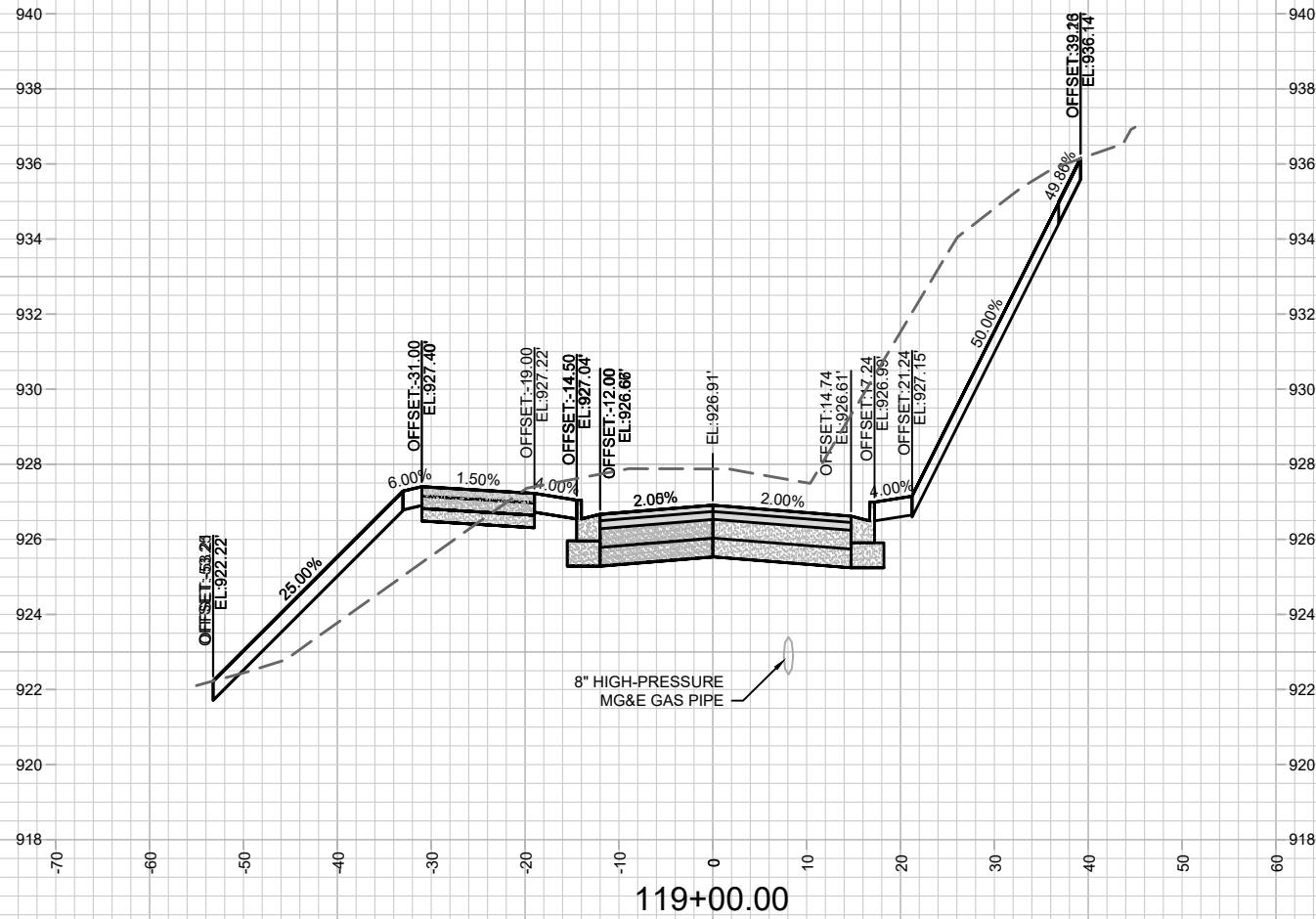

8" HIGH-PRESSURE  
MG&E GAS PIPE



13270  
X-6

FELLAND ROAD - CROSS SECTIONS

FELLAND ROAD & TRANQUILITY TRAIL ROUNDABOUT

MADISON, WI

13270

CONTRACT NO:

8564

MARK	REVISION	DATE	BY
13270	Designed By: AJC	Date: 5/11/2021 9:38 AM	Scale: #####
			X-6



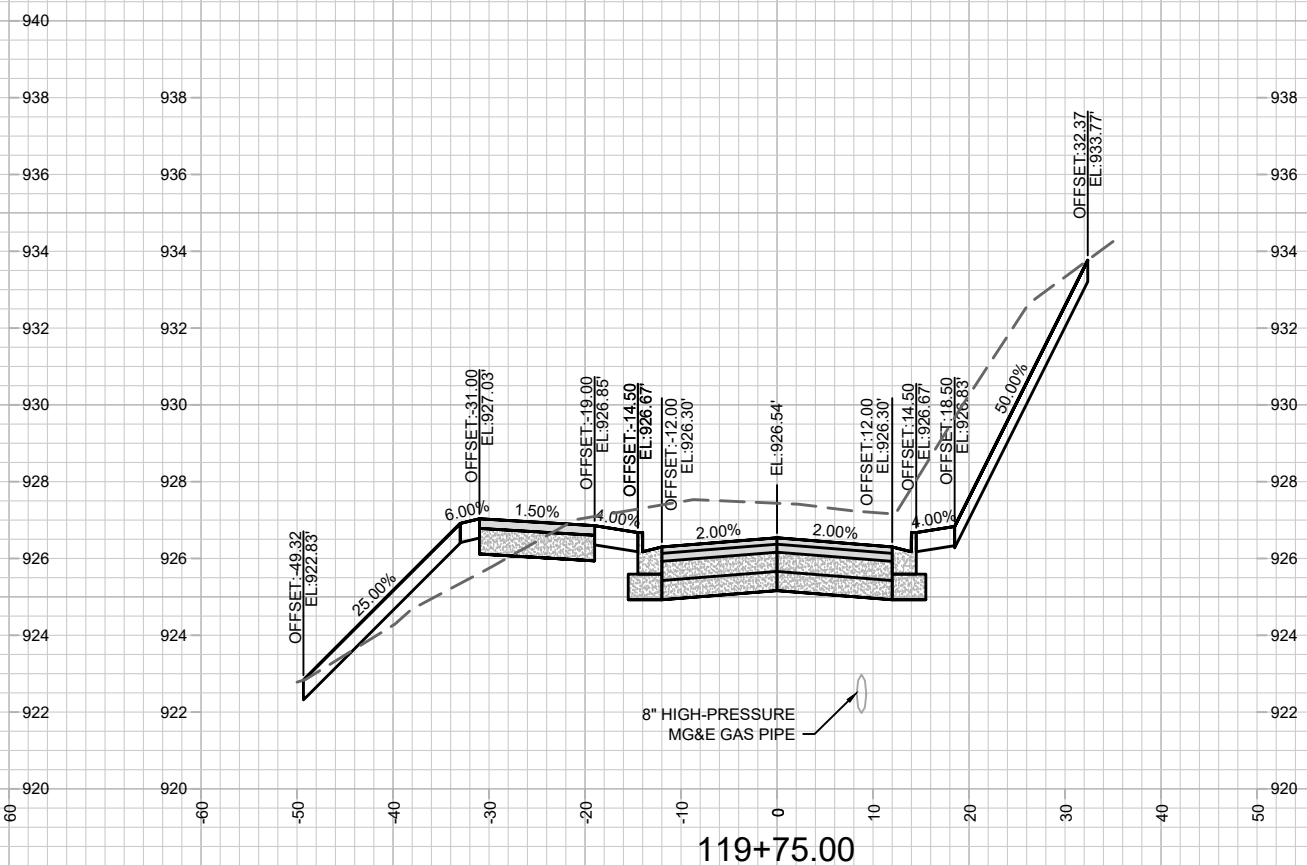
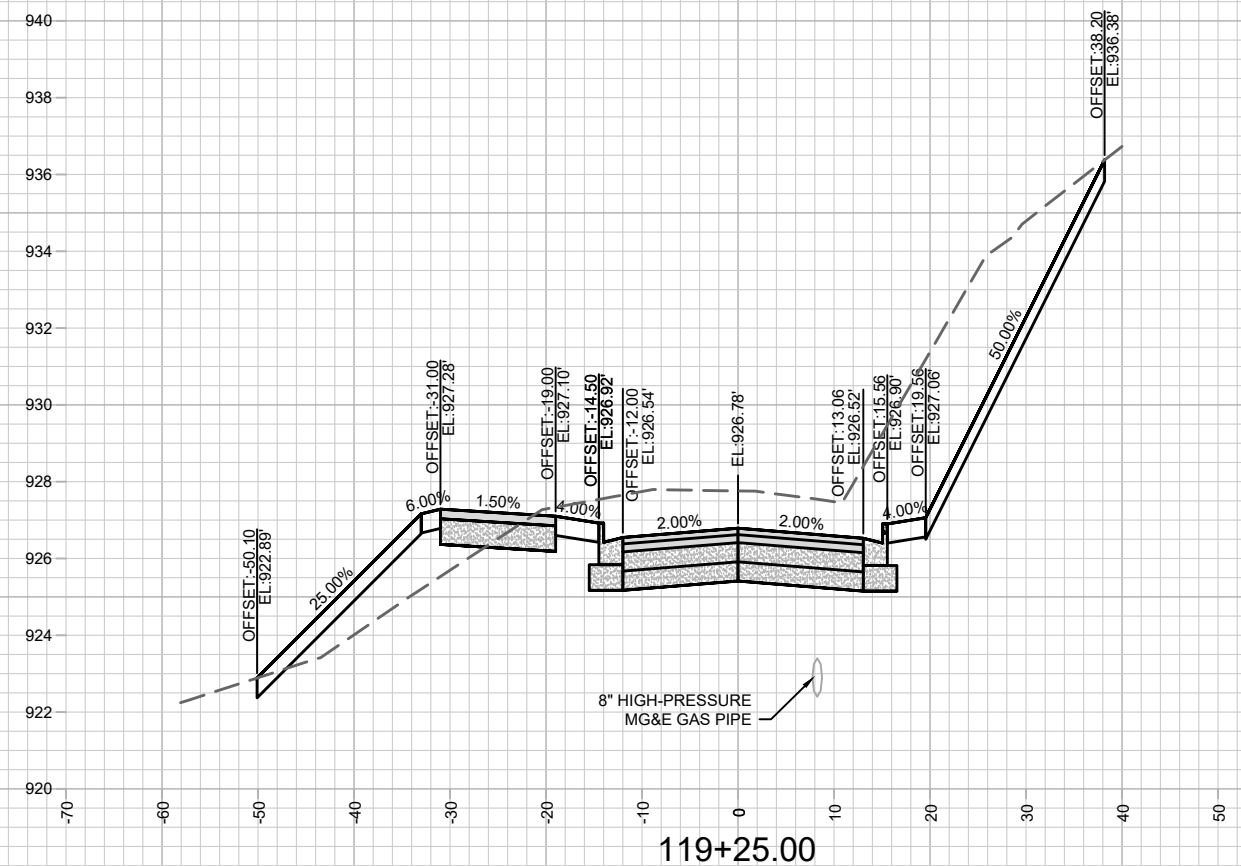
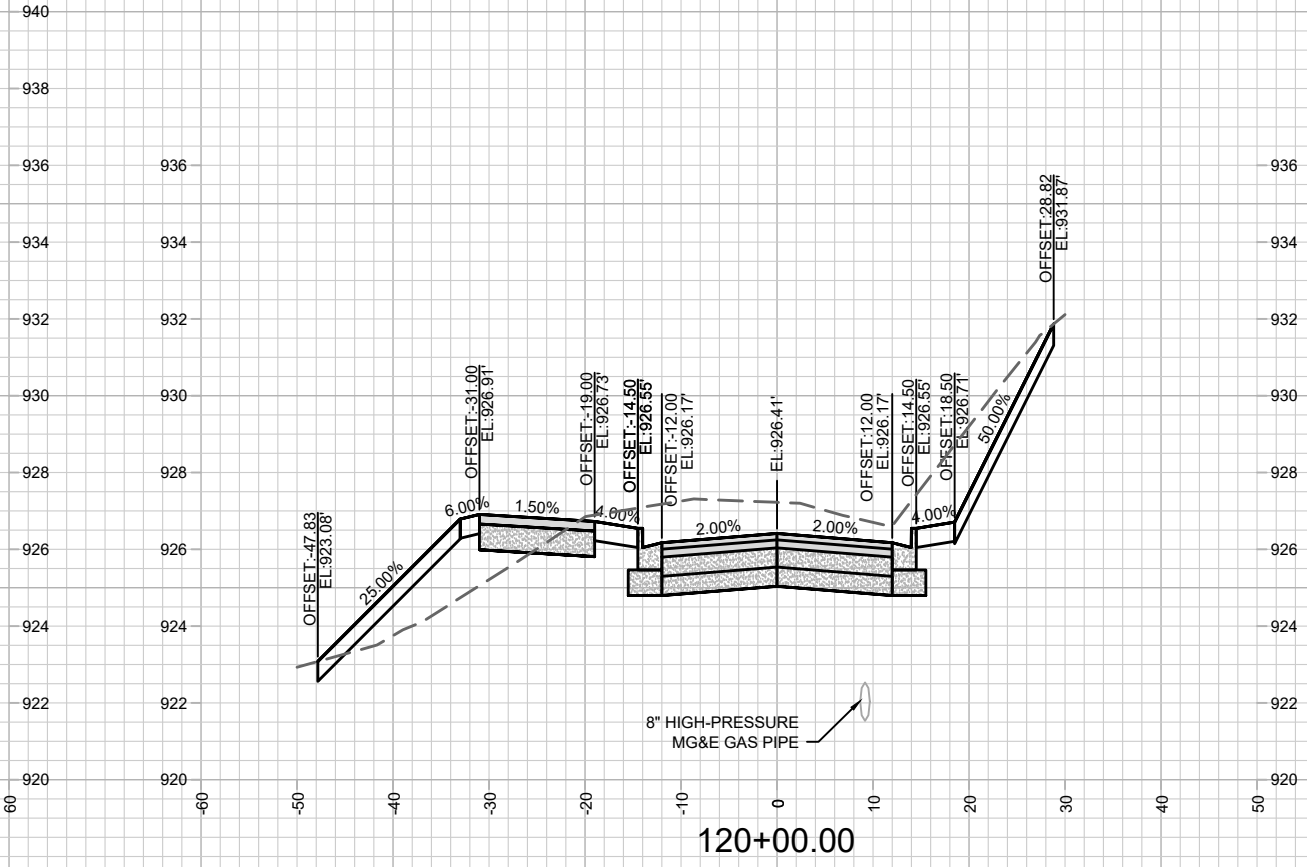
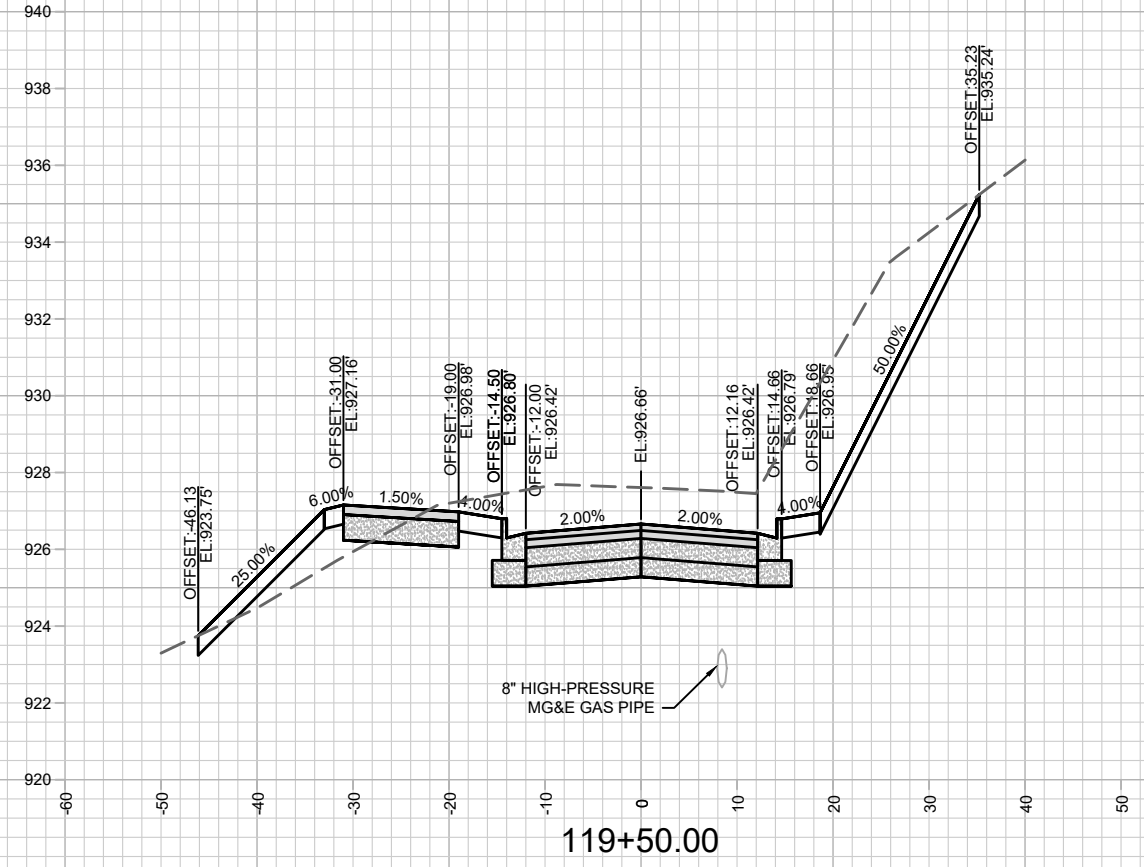

MARK	REVISION	DATE	BY

13270  
 MADISON, WI  
 8564  
 CONTRACT NO:

FELLAND ROAD - CROSS SECTIONS  
 FELLAND ROAD & TRANQUILITY TRAIL ROUNDABOUT  
 M:\DESIGN\Projects\13303\CAD\Streets\13270\EN-FellandRABCorridor.dwg

13270  
 X-7

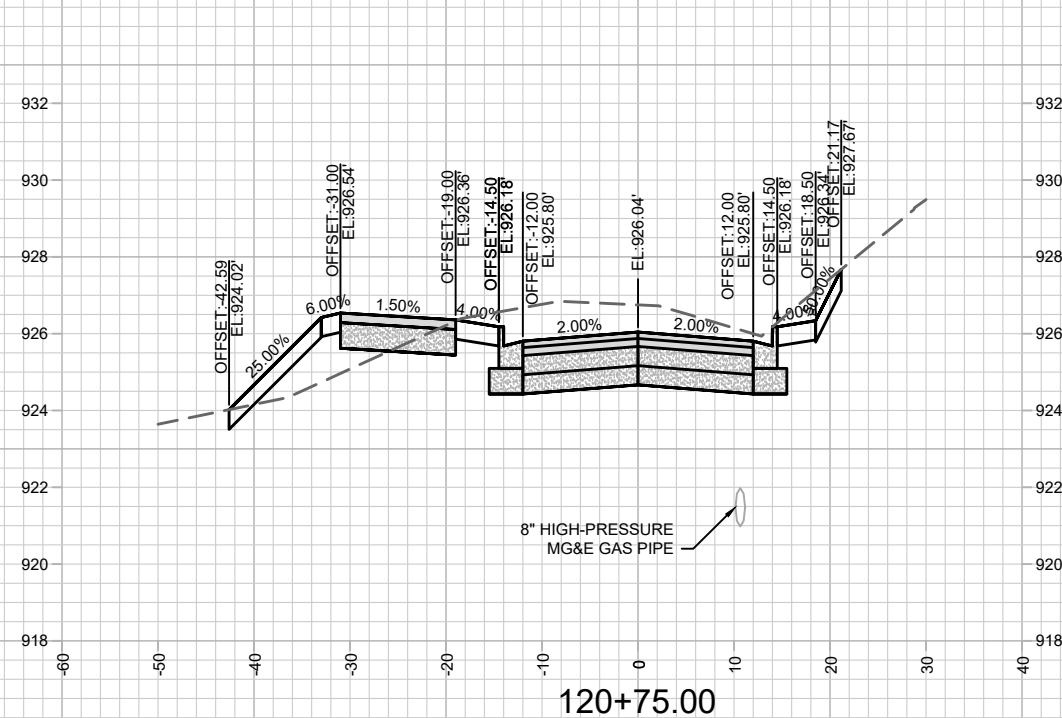
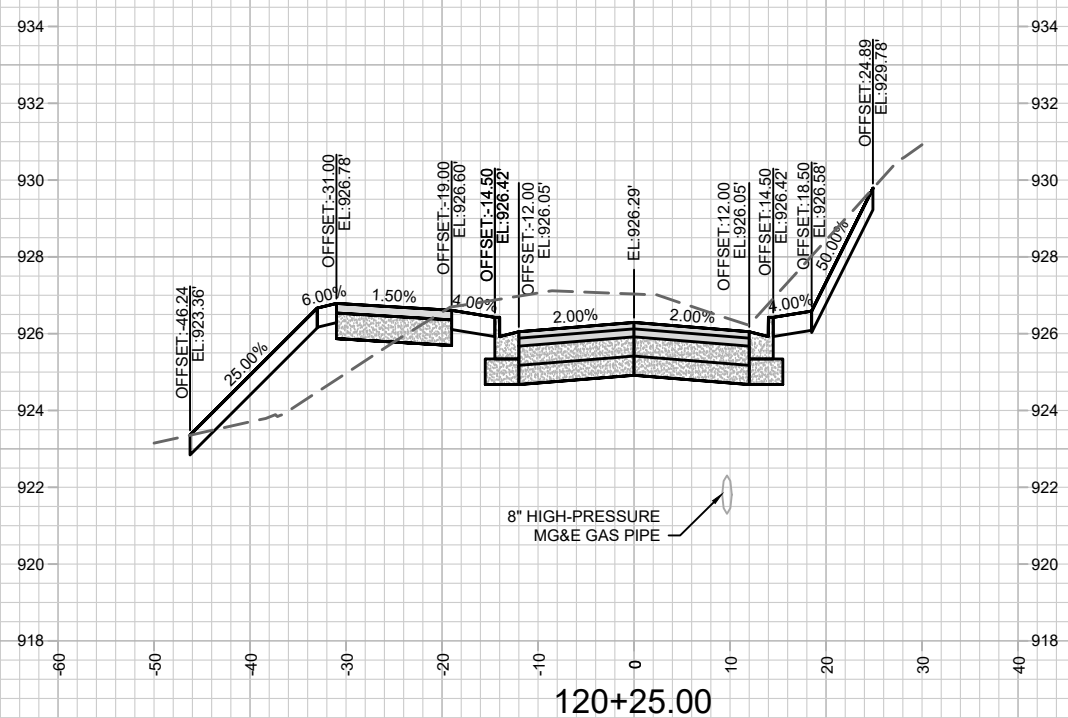
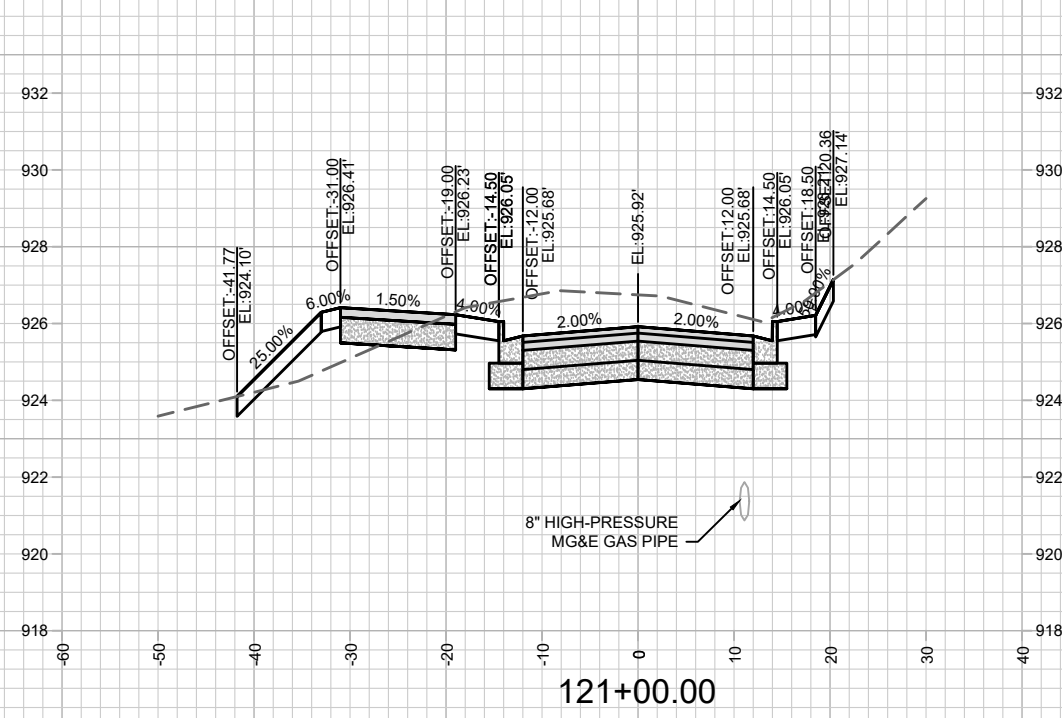
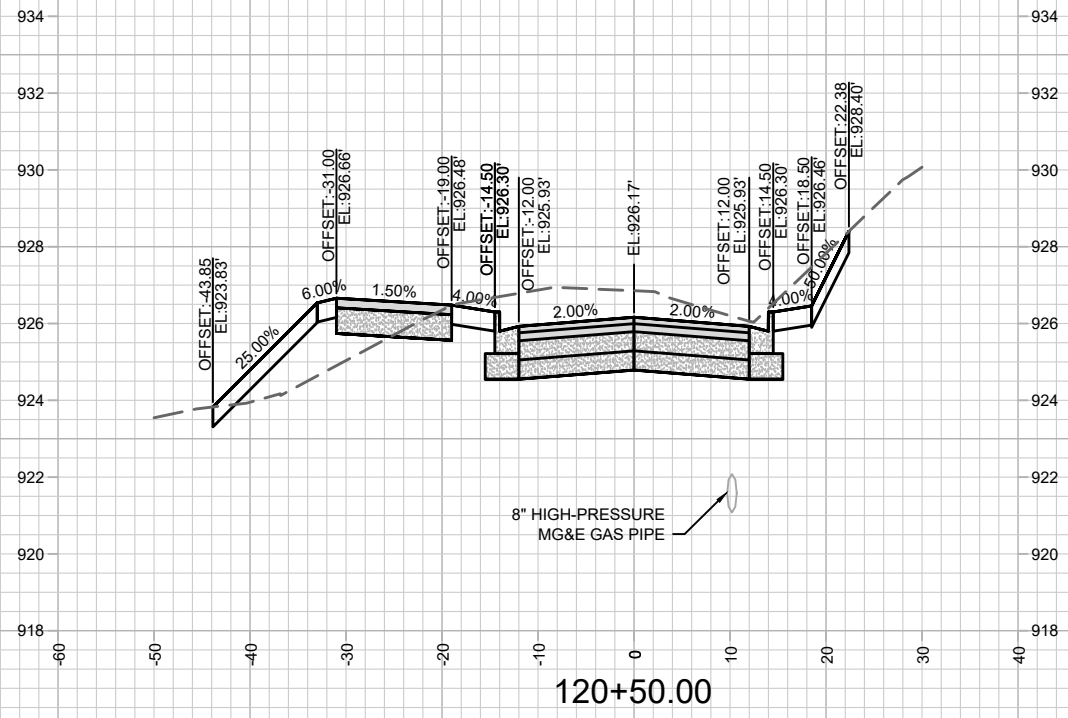

MARK	REVISION	DATE	BY

Designed By: AJC Date: 5/11/2021 9:38 AM Scale: ##### X-8

13270  
MADISON, WI  
8564  
CONTRACT NO:

FELLAND ROAD - CROSS SECTIONS  
FELLAND ROAD & TRANQUILITY TRAIL ROUNDABOUT  
M:\DESIGN\Projects\13303\CAD\Streets\13270\EN-FellandRABCorridor.dwg

13270  
X-8

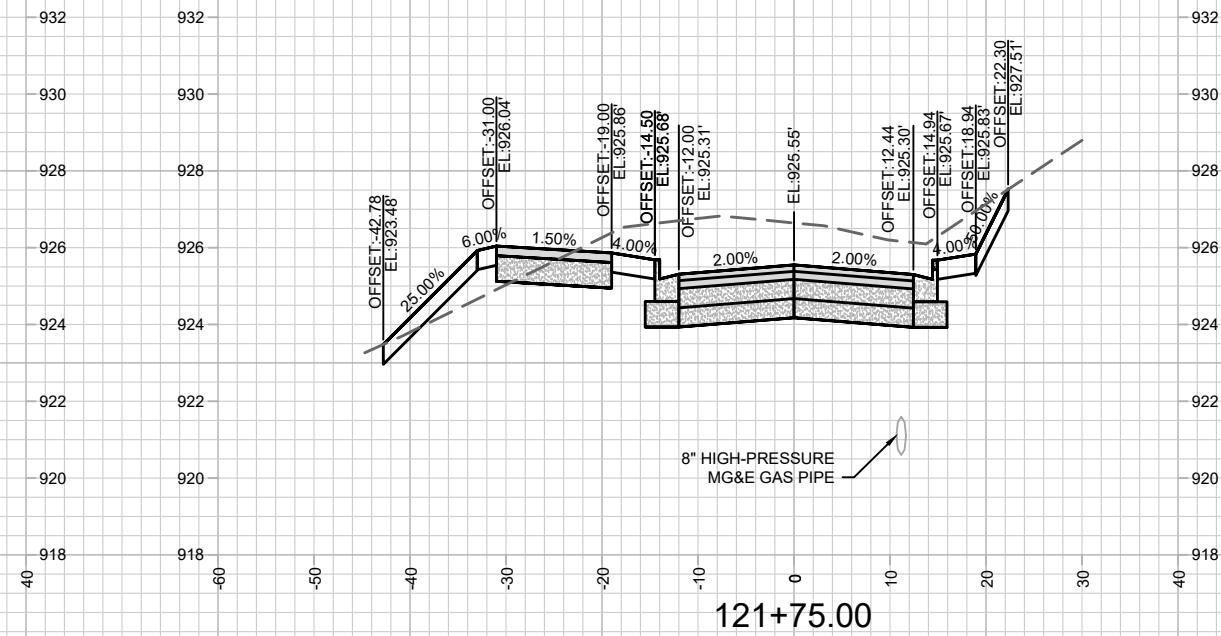
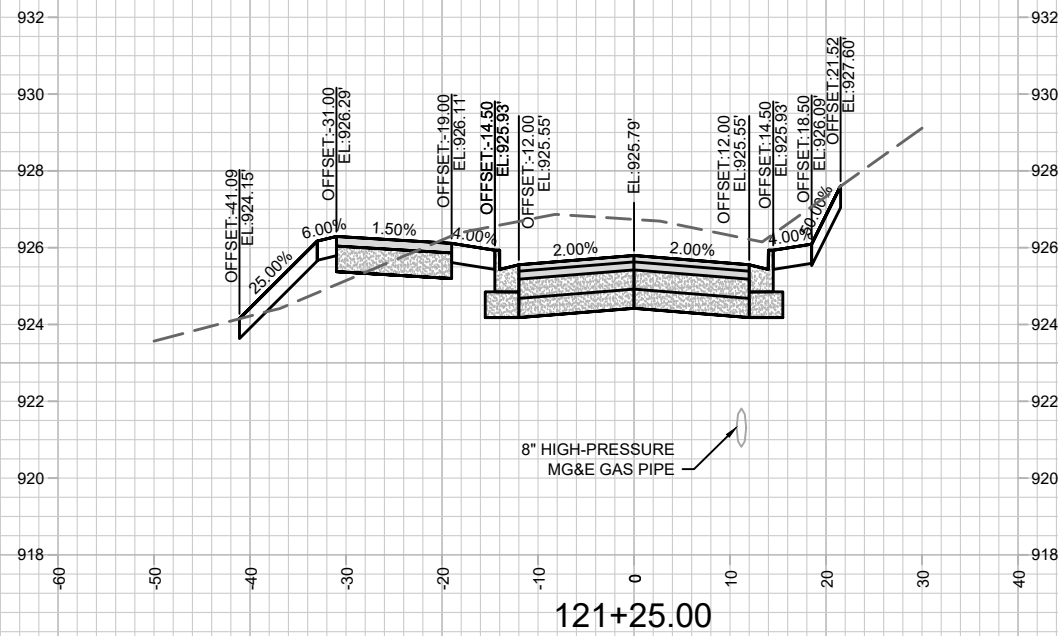
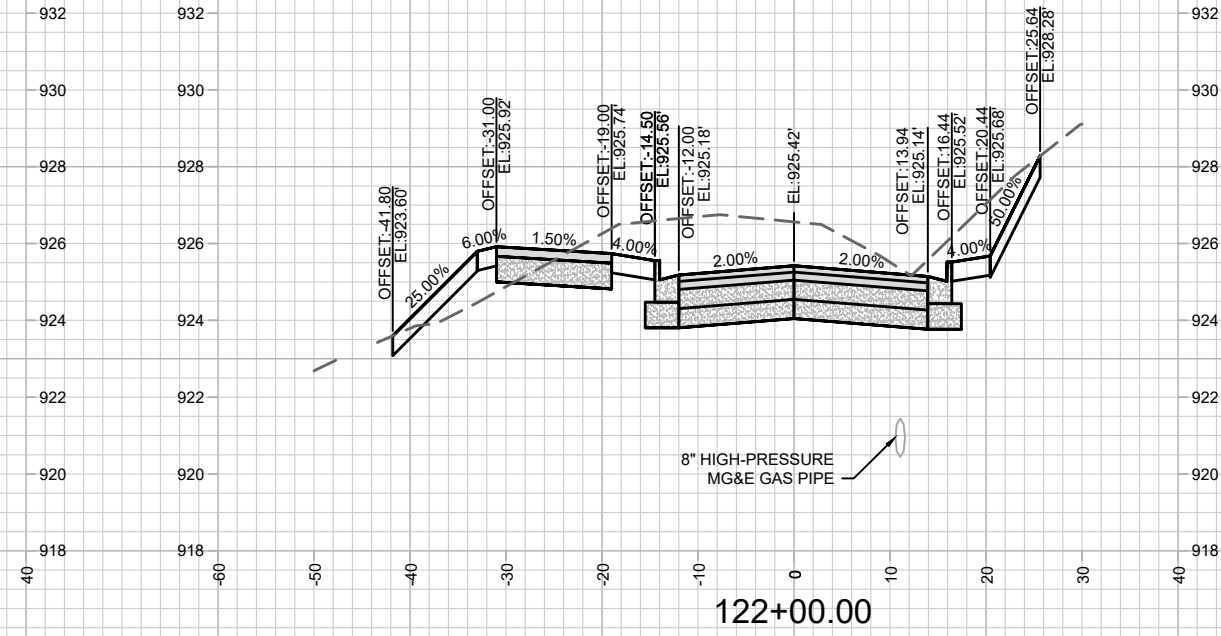
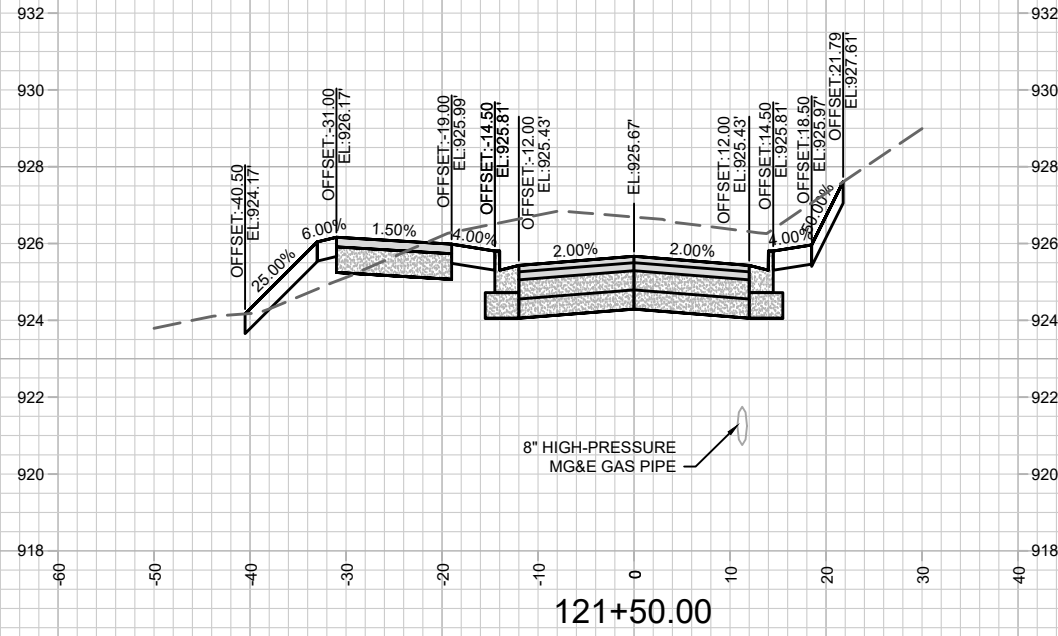

MARK	REVISION	DATE	BY

Designed By: AJC  
Date: 5/11/2021 9:38 AM  
Scale: #####

13270  
MADISON, WI  
8564  
CONTRACT NO:

FELLAND ROAD - CROSS SECTIONS  
FELLAND ROAD & TRANQUILITY TRAIL ROUNDABOUT  
M:\DESIGN\Projects\13303\CAD\Streets\13270\EN-FellandRABCorridor.dwg



13270  
X-9

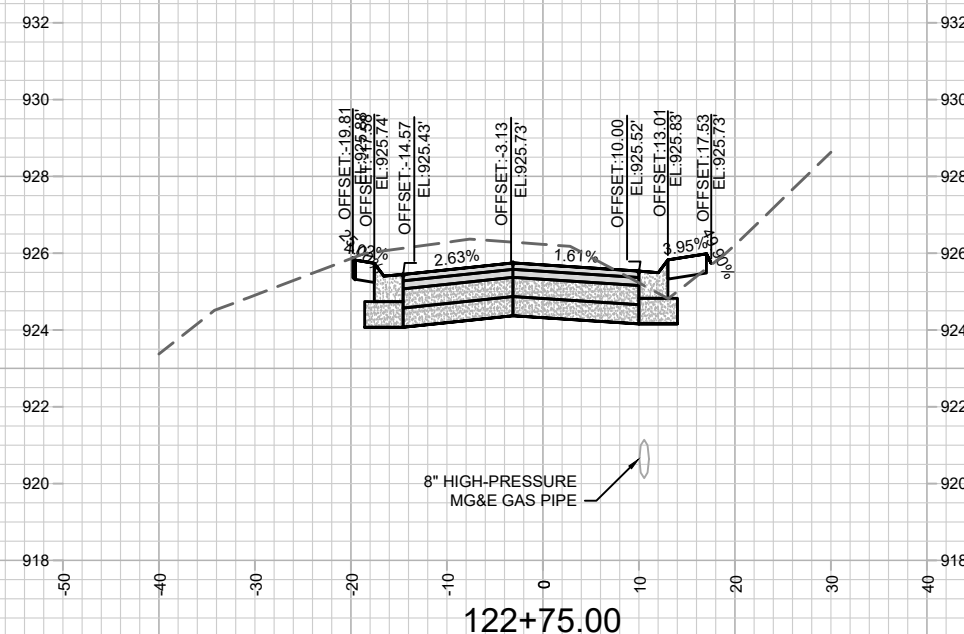
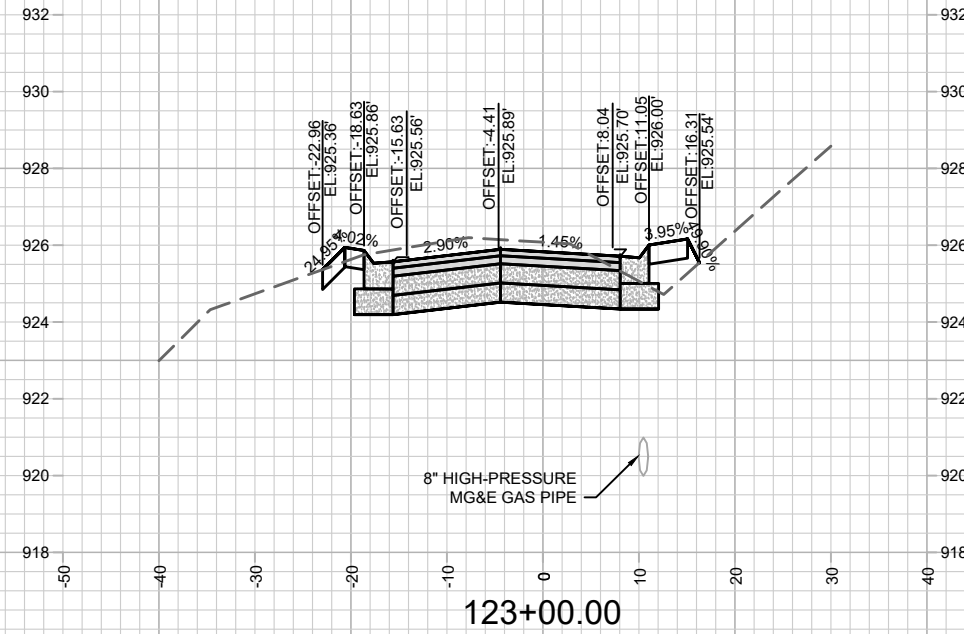
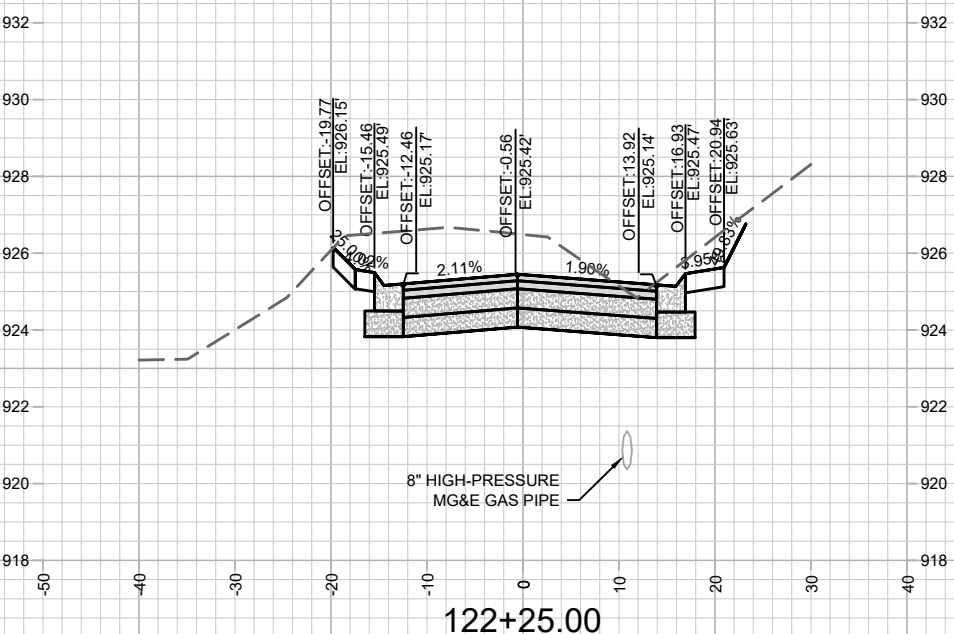
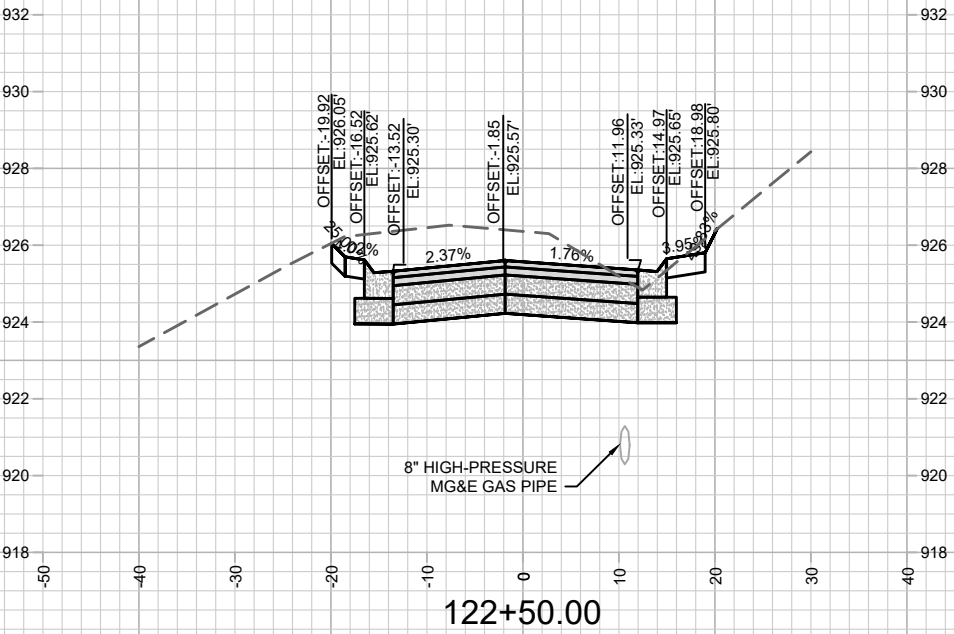

MARK	REVISION	DATE	BY
13270	5/11/2021 9:39 AM	#####	X-10

13270  
 MADISON, WI  
 8564  
 CONTRACT NO:  
 FELLAND ROAD - CROSS SECTIONS  
 FELLAND ROAD & TRANQUILITY TRAIL ROUNDABOUT  
 M:\DESIGN\Projects\13303\CAD\Streets\13270\EN-FellandRABCorridor.dwg



13270  
 X-10

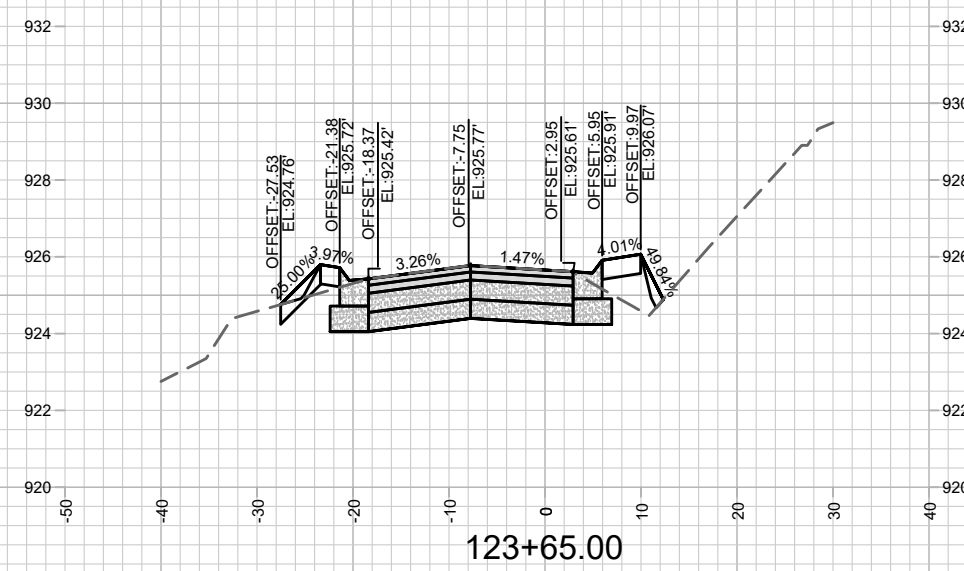
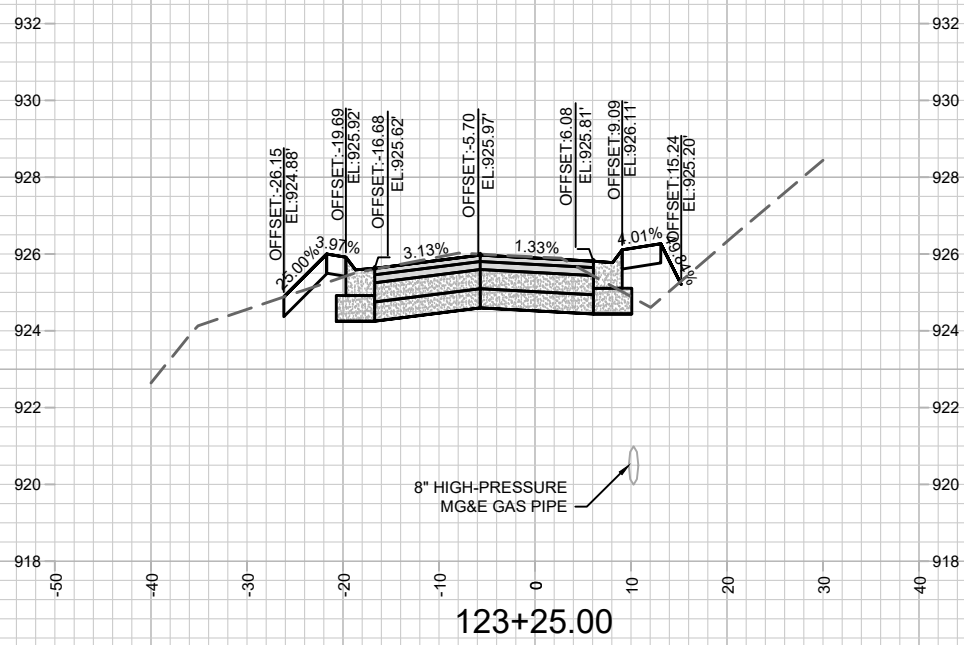
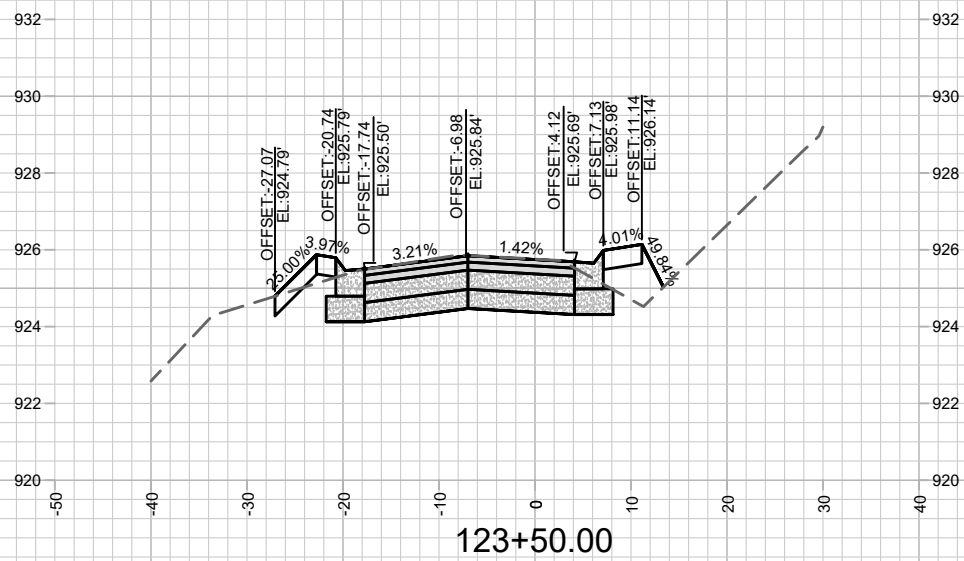

MARK	REVISION	DATE	BY

13270  
 MADISON, WI  
 8564  
 CONTRACT NO:

FELLAND ROAD - CROSS SECTIONS  
 FELLAND ROAD & TRANQUILITY TRAIL ROUNDABOUT  
 M:\DESIGN\Projects\13303\CAD\Streets\13270\EN-FellandRABCorridor.dwg

13270  
 X-11





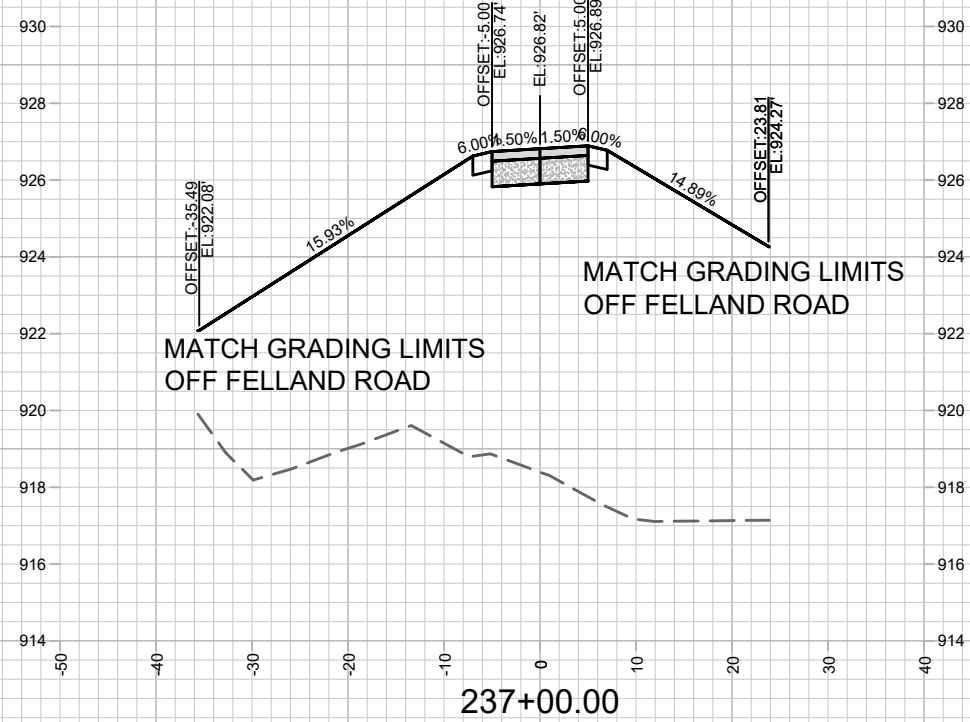
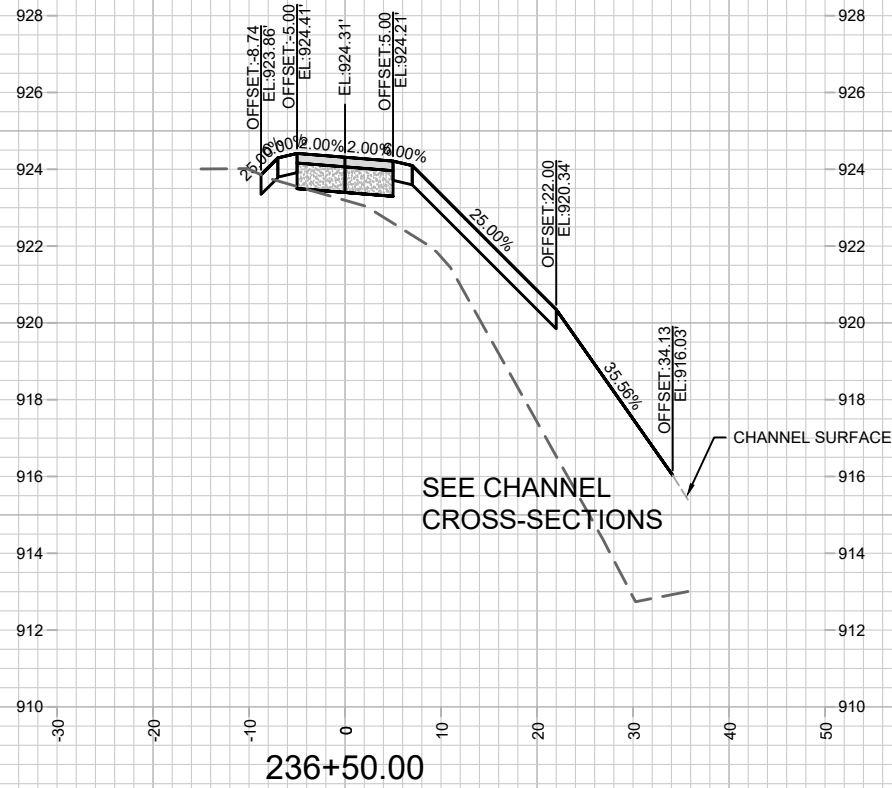
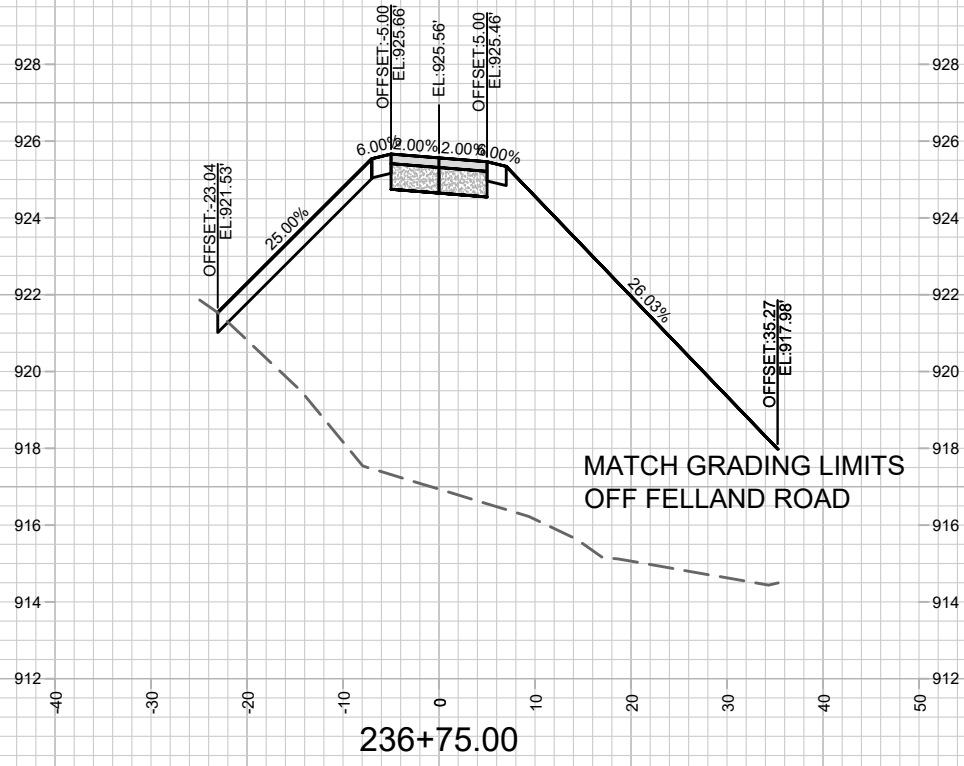

MARK	REVISION	DATE	BY
13270	5/11/2021 4:06 PM	#####	X-13

13270  
 MADISON, WI  
 8564  
 CONTRACT NO:

OL 46 PATH - CROSS SECTIONS  
 FELLAND ROAD & TRANQUILITY TRAIL ROUNDABOUT  
 M:\DESIGN\Projects\13303\CAD\Streets\13270EN-FellandRABCorridor.dwg



13270  
 X-13

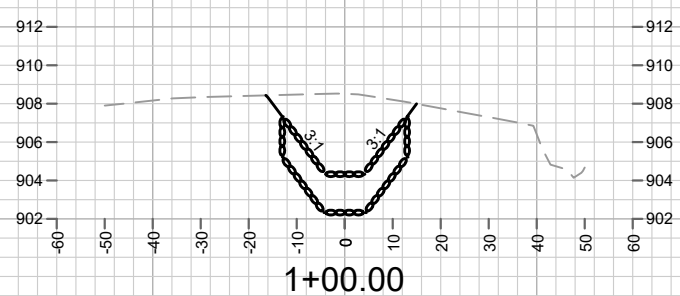
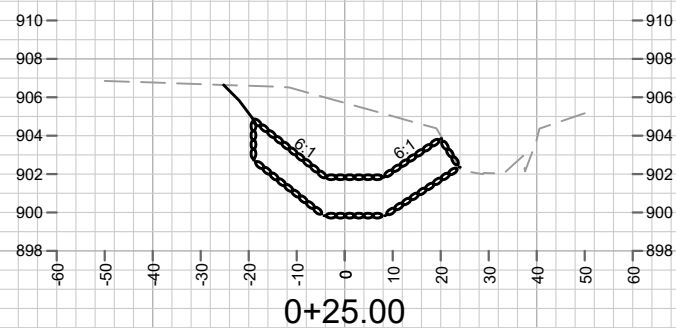
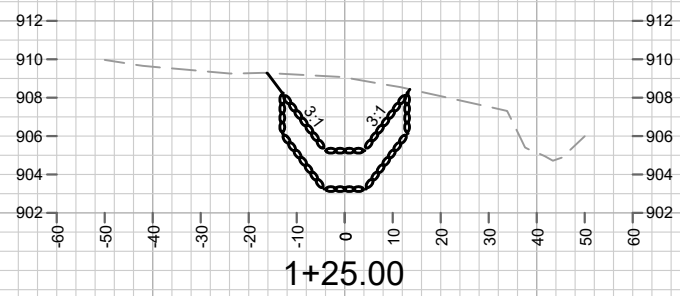
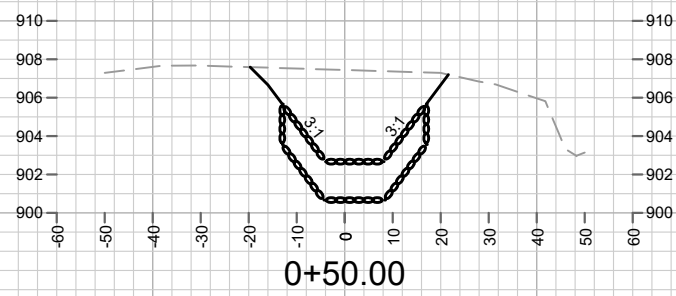
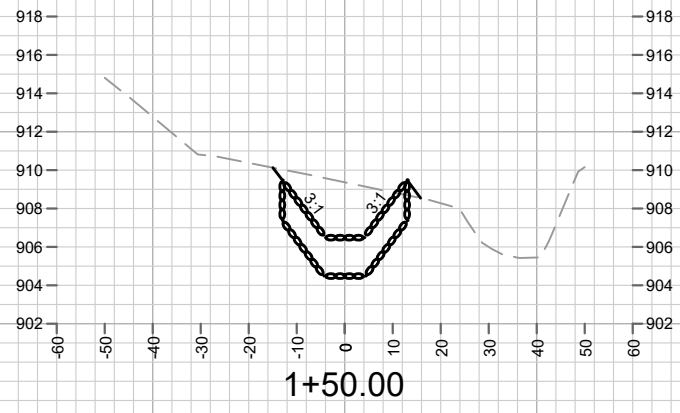
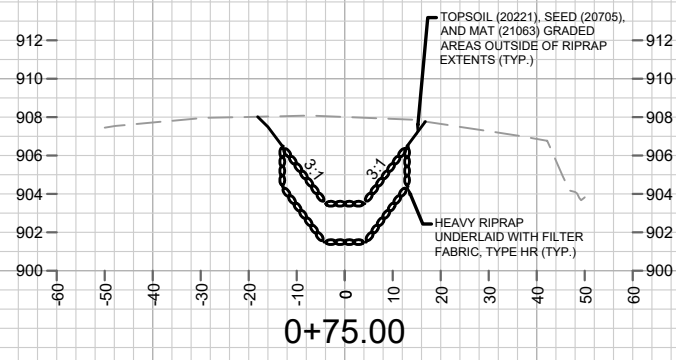

MARK	REVISION	DATE	BY
13270	Designed By: MAA	Date: 5/13/2021 4:46 PM	Scale: 1:40

13270  
 MADISON, WI  
 CONTRACT NO: 8564

FELLAND ROAD CHANNEL CROSS SECTIONS  
 FELLAND ROAD & TRANQUILITY TRAIL ROUNDABOUT  
 M:\DESIGN\Projects\13270\CAD\Sewers\13270SWR-PipeNetwork.dwg



13270  
 C-1

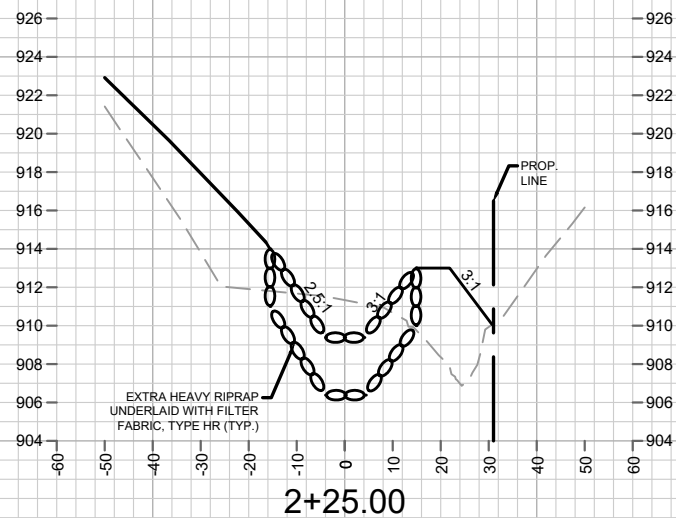
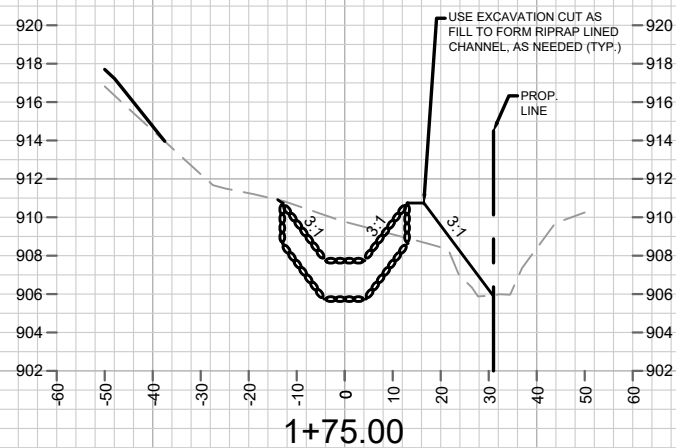
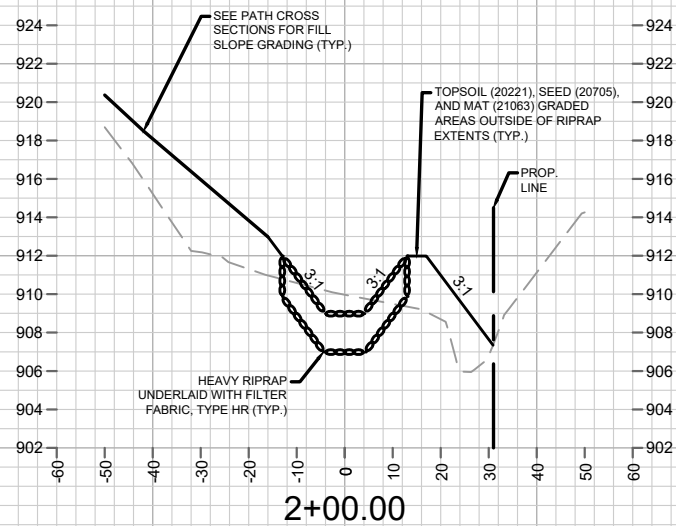

MARK	REVISION	DATE	BY
13270	5/13/2021 4:46 PM		
Designed By: MAA		Scale: 1"=40'	

13270  
 MADISON, WI  
 8564  
 CONTRACT NO:  
 M:\DESIGN\Projects\13270\CAD\Sewers\13270SWR-PipeNetwork.dwg



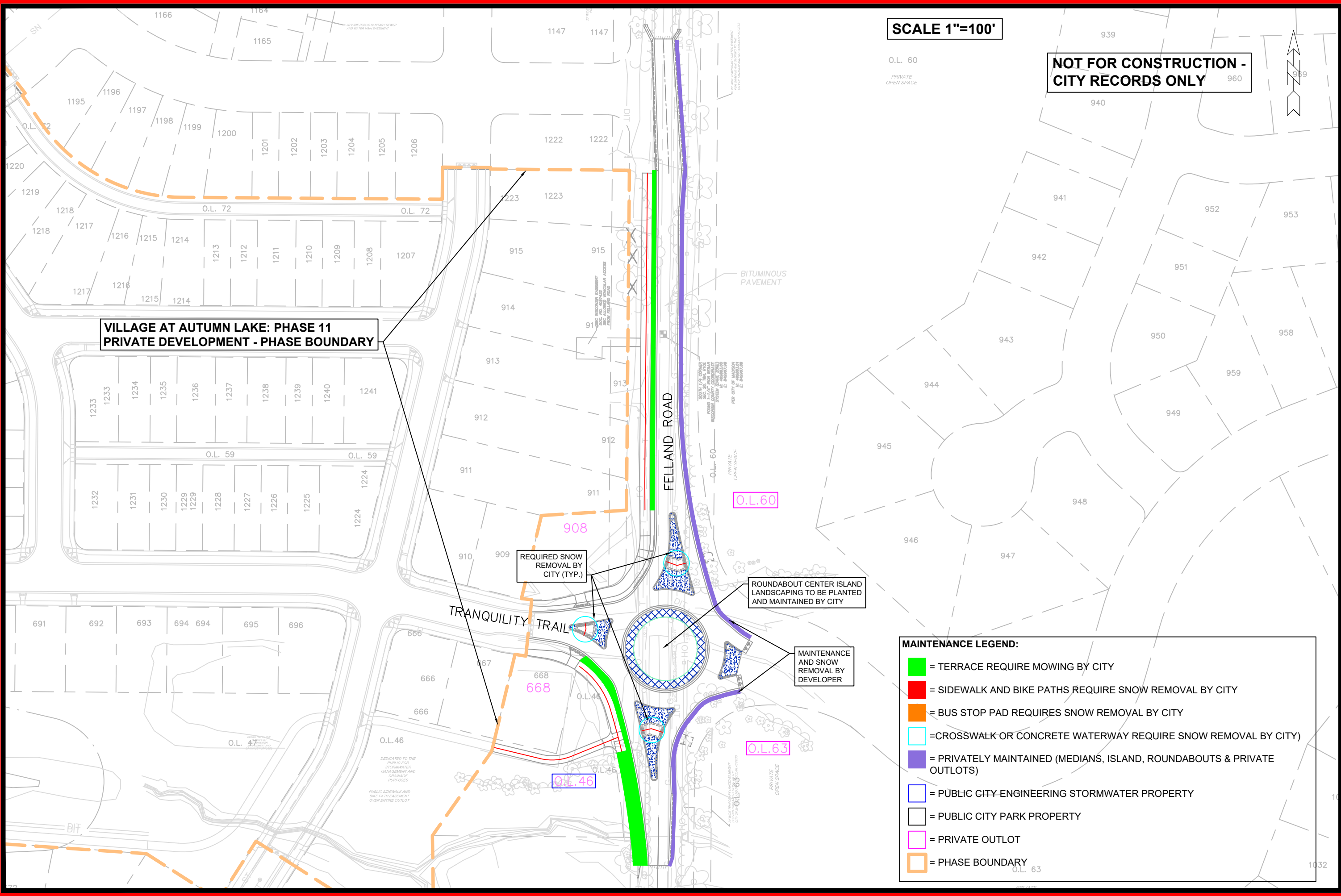

MARK	REVISION	DATE	BY

**13270**  
**MADISON, WI**  
**8564**  
**CONTRACT NO:**

**MAINTENANCE MAP**  
**FELLAND ROAD & TRANQUILITY TRAIL ROUNDABOUT**  
 M:\DESIGN\Projects\13303\CAD\Streets\13270EN-FellandRAB-Maintenance.dwg

  
**13270**  
**MN-1**