

**RUSH**

Contract Routing Form

ROUTING: Urgent Rush

printed on: 03/16/2015

Contract between: Midwest General & Mechanical Contractors Inc  
and Dept. or Division: Engineering Division  
Name/Phone Number:

Project: Booster Pump Station 115 Upgrade

Contract No.: 7411  
Enactment No.: RES-15-00158  
Dollar Amount: 922,582.00

File No.: 36800  
Enactment Date: 02/26/2015

Contract Posted In Munis.  
KLSV

(Please DATE before routing)

Signatures Required	Date Received	Date Signed
City Clerk	3-16-2015	3-16-2015
Director of Civil Rights	3.16.15	3/17/15 MDO
Risk Manager	3-17-15	3/17/15 RSR
Finance Director	3-17-15 KLSV	3-19-15
City Attorney	294 3-19-15	3-19-15
Mayor	3-19-15	3-20-15

Please return signed Contracts to the City Clerk's Office  
Room 103, City-County Building for filing.

Original + 2 Copies

03/16/2015 09:37:45 enjap - Kelly Miess - 261-9640

**RUSH**

**RUSH**

Dis Rights: OK / N/A / Problem - Hold  
Prev Wage: AA / Agency / No  
Contract Value: See above  
AA Plan: Permit for bid  
Amendment / Addendum #  
Type: POS / Dylp / Sbdv / Gov't /  
Grant / PW / Goal / Loan / Agrmt



# City of Madison

City of Madison  
Madison, WI 53703  
www.cityofmadison.com

## Master

**File Number: 36800**

<b>File ID:</b> 36800	<b>File Type:</b> Resolution	<b>Status:</b> Passed
<b>Version:</b> 1	<b>Reference:</b>	<b>Controlling Body:</b> BOARD OF PUBLIC WORKS
<b>Lead Referral:</b> BOARD OF PUBLIC WORKS	<b>Cost:</b>	<b>File Created Date :</b> 01/09/2015
<b>File Name:</b> Awarding Public Works Contract No. 7411, Booster Pump Station 115 Upgrade.		<b>Final Action:</b> 02/24/2015

**Title:** Awarding Public Works Contract No. 7411, Booster Pump Station 115 Upgrade.

**Notes:** Kelly M

**CC Agenda Date:** 02/24/2015

**Agenda Number:** 42.

**Sponsors:** BOARD OF PUBLIC WORKS

**Effective Date:** 02/26/2015

**Attachments:** Contract 7411.pdf

**Enactment Number:** RES-15-00158

**Author:** Rob Phillips City Engineer

**Hearing Date:**

**Entered by:** mhacker@cityofmadison.com

**Published Date:**

### Approval History

Version	Date	Approver	Action
1	01/27/2015	Craig Franklin	Approve

### History of Legislative File

Ver- sion:	Acting Body:	Date:	Action:	Sent To:	Due Date:	Return Date:	Result:
1	Engineering Division	01/09/2015	Refer	BOARD OF PUBLIC WORKS	01/21/2015	02/04/2015	
	<b>Action Text:</b> This Resolution was Refer to the BOARD OF PUBLIC WORKS due back on 1/21/2015						
	<b>Notes:</b>						
1	BOARD OF PUBLIC WORKS	01/21/2015	Refer	BOARD OF PUBLIC WORKS		02/04/2015	Pass
	<b>Action Text:</b> A motion was made by Skidmore, seconded by Branson, to Refer to the BOARD OF PUBLIC WORKS. The motion passed by voice vote/other.						
	<b>Notes:</b>						

1 BOARD OF PUBLIC WORKS 02/04/2015 RECOMMEND TO COUNCIL TO ADOPT UNDER SUSPENSION OF RULES 2.04, 2.05, 2.24, & 2.25 - REPORT OF OFFICER Pass

**Action Text:** A motion was made by Fix, seconded by Branson, to RECOMMEND TO COUNCIL TO ADOPT UNDER SUSPENSION OF RULES 2.04, 2.05, 2.24, & 2.25 - REPORT OF OFFICER, including Alternate 1. The motion passed by voice vote/other.

1 COMMON COUNCIL 02/24/2015 Adopt Under Suspension of Rules 2.04, 2.05, 2.24, and 2.25 Pass

**Action Text:** A motion was made by Schmidt, seconded by DeMarb, to Adopt Under Suspension of Rules 2.04, 2.05, 2.24, and 2.25. The motion passed by voice vote/other.

**Notes:**

---

**Text of Legislative File 36800**

**Fiscal Note**

Budget authority is available in the Acct. Nos. listed on the attached.

**Title**

Awarding Public Works Contract No. 7411, Booster Pump Station 115 Upgrade.

**Body**

BE IT RESOLVED, that the following low bids for miscellaneous improvements be accepted and that the Mayor and City Clerk be and are hereby authorized and directed to enter into a contract with the low bidders contained herein, subject to the Contractor's compliance with Section 39.02 of the Madison General Ordinances concerning compliance with the Affirmative Action provisions **and subject to the Contractor's compliance with Section 33.07 of the Madison General Ordinances regarding Best Value Contracting:**

BE IT FURTHER RESOLVED, that the funds be encumbered to cover the cost of the projects contained herein.

See attached document (Contract No. 7411) for itemization of bids.

PROJECT \_\_\_\_\_ CONTRACTOR \_\_\_\_\_ AMOUNT OF BID \_\_\_\_\_

CONTRACT NO. 7411  
BOOSTER PUMP STATION 115 UPGRADE  
(TOTAL BID \$899,585.00 + ALT. #1 \$22,997.00)

MIDWEST GENERAL & MECHANICAL CONTRACTORS, INC.

\$922,582.00

10456-86-150:53410	\$922,582.00
Contingency 8%±	<u>73,808.00</u>
 GRAND TOTAL	 <u>\$996,390.00</u>



**Wisconsin Office of the Commissioner of Insurance  
Licensed Producer Search**

Tuesday, March 10, 2015

P2

DOWNEY, ROBERT SCHAD  
HUDSON WI

License Status: Active  
License No: 2587534  
NPN No: 16171611  
Effective Date: 12-09-2011  
Expiration Date: 10-31-2015  
License Type: Resident Intermediary Indv

**Lines of Authority**

Line of Authority	Residency	Effective Date	Status
Property	Resident	12-09-2011	Active
	Non-Resident	12-09-2011	Inactive
Casualty	Non-Resident	03-16-2011	Active
	Resident	12-09-2011	Active
	Non-Resident	12-09-2011	Inactive
	Non-Resident	03-16-2011	Active

**Appointments and Terminations**

Company Name	Qualification Type/Status	Effective Date	Termination Date	Termination Reason
American Contractors Indemnity Company	CAS/Inactive SUR/Active	09-29-2011 12-12-2011	12-09-2011	Canceled
American Economy Insurance Company	CAS/Active PROP/Active	12-21-2011 12-21-2011		
American Fire and Casualty Company	CAS/Active PROP/Active	12-21-2011 12-21-2011		
American States Insurance Company	CAS/Active PROP/Active	12-21-2011 12-21-2011		
Berkley Insurance Company	CAS/Active	08-26-2013		
Bond Safeguard Insurance Company	SUR/Inactive	03-24-2011	12-09-2011	Canceled
Citizens Insurance Company of America	CAS/Active PROP/Active	12-28-2011 12-28-2011		
Consolidated Insurance Company	CAS/Active PROP/Active	12-21-2011 12-21-2011		
First National Insurance Company	CAS/Active PROP/Active	12-21-2011 12-21-2011		

of America					
First Sealord Surety, Inc.	SUR/Inactive	04-04-2011	12-09-2011		Canceled
General Insurance Company of America	CAS/Active	12-21-2011			
	PROP/Active	12-21-2011			
Granite Re, Inc.	CAS/Inactive	03-22-2011	12-09-2011		Canceled
	SUR/Active	03-21-2012			
Guarantee Company of North America USA, The	CAS/Active	12-28-2011			
Hanover Insurance Company, The	CAS/Active	12-28-2011			
	PROP/Active	12-28-2011			
Hawkeye-Security Insurance Company	CAS/Active	12-21-2011			
	PROP/Active	12-21-2011			
IMT Insurance Company	CAS/Inactive	06-08-2011	12-09-2011		Canceled
	PROP/Inactive	06-08-2011	12-09-2011		Canceled
Indiana Insurance Company	CAS/Active	12-21-2011			
	PROP/Active	12-21-2011			
Lexon Insurance Company	SUR/Active	12-21-2011			
	SUR/Inactive	03-24-2011	12-09-2011		Canceled
Liberty Mutual Fire Insurance Company	CAS/Active	01-13-2012			
Liberty Mutual Insurance Company	CAS/Active	01-13-2012			
LM Insurance Corporation	CAS/Active	01-13-2012			
Massachusetts Bay Insurance Company	CAS/Active	12-28-2011			
	PROP/Active	12-28-2011			
Merchants Bonding Company (Mutual)	CAS/Active	12-20-2011			
	CAS/Inactive	03-23-2011	12-09-2011		Canceled
Merchants National Bonding, Inc.	CAS/Active	02-06-2013			
Meridian Security Insurance Company	CAS/Active	06-27-2012			
	PROP/Active	06-27-2012			
Milbank Insurance Company	CAS/Active	06-27-2012			
	PROP/Active	06-27-2012			
Netherlands Insurance Company,	CAS/Active	12-21-2011			
	PROP/Active	12-21-2011			

The					
Ohio Casualty Insurance Company, The	CAS/Active	12-21-2011			
	PROP/Active	12-21-2011			
Ohio Security Insurance Company	CAS/Active	12-21-2011			
	PROP/Active	12-21-2011			
Old Republic Insurance Company	CAS/Active	02-20-2012			
	CAS/Inactive	03-22-2011	12-09-2011		Canceled
Old Republic Surety Company	CAS/Active	02-20-2012			
	CAS/Inactive	03-22-2011	12-09-2011		Canceled
Peerless Indemnity Insurance Company	CAS/Active	12-21-2011			
	PROP/Active	12-21-2011			
Peerless Insurance Company	CAS/Active	12-21-2011			
	PROP/Active	12-21-2011			
SAFECO Insurance Company of America	CAS/Active	12-21-2011			
	PROP/Active	12-21-2011			
Star Insurance Company	CAS/Inactive	01-03-2012	12-12-2013		Canceled
	CAS/Inactive	04-05-2011	12-09-2011		Canceled
	PROP/Inactive	01-03-2012	12-12-2013		Canceled
	PROP/Inactive	04-05-2011	12-09-2011		Canceled
State Auto Insurance Company of Wisconsin	CAS/Active	06-27-2012			
	PROP/Active	06-27-2012			
State Auto Property and Casualty Insurance Company	CAS/Active	06-27-2012			
	PROP/Active	06-27-2012			
State Automobile Mutual Insurance Company	CAS/Active	06-27-2012			
	PROP/Active	06-27-2012			
U.S. Specialty Insurance Company	CAS/Inactive	09-29-2011	12-09-2011		Canceled
	SUR/Active	12-12-2011			
United Fire & Casualty Company	CAS/Active	08-15-2014			
	PROP/Active	08-15-2014			
Wadena Insurance Company	CAS/Inactive	06-08-2011	12-09-2011		Canceled
	PROP/Inactive	06-08-2011	12-09-2011		Canceled
West American Insurance Company	CAS/Active	12-21-2011			
	PROP/Active	12-21-2011			
Western National Mutual Insurance	CAS/Active	06-20-2012			
	PROP/Active	06-20-2012			

Company	SUR/Active	06-20-2012		
Western Surety	CAS/Active	01-07-2013		
Company	CAS/Inactive	03-24-2011	12-09-2011	Canceled

**DISCLAIMER:** The Office of the Commissioner of Insurance does not endorse any specific agent or insurance agency. You are encouraged to contact the Agent Licensing Section at if you have any concerns with any of the agents or agencies listed.

\$922,582.00  
FILE

BID OF MIDWEST GENERAL & MECHANICAL CONTRACTORS, INC.

2015

PROPOSAL, CONTRACT, BOND AND SPECIFICATIONS

FOR

BOOSTER PUMP STATION 115 UPGRADE

CONTRACT NO. 7411

MUNIS NO. 10456

IN

MADISON, DANE COUNTY, WISCONSIN

AWARDED BY THE COMMON COUNCIL  
MADISON, WISCONSIN ON FEBRUARY 24, 2015

CITY ENGINEERING DIVISION  
1600 EMIL STREET  
MADISON, WISCONSIN 53713

<https://bidexpress.com/login>

**BOOSTER PUMP STATION 115 UPGRADE**

**CONTRACT NO. 7411**

**INDEX**

SECTION A: ADVERTISEMENT FOR BIDS AND INSTRUCTIONS TO BIDDERS ..... A-1

SECTION B: PROPOSAL SECTION ..... B-1

SECTION C: SMALL BUSINESS ENTERPRISE ..... C-1

SECTION D: SPECIAL PROVISIONS ..... D-1

SECTION E: BIDDER'S ACKNOWLEDGEMENT ..... E-1

SECTION F: DISCLOSURE OF OWNERSHIP & BEST VALUE CONTRACTING ..... F-1

SECTION G: BID BOND ..... G-1

SECTION H: AGREEMENT ..... H-1

SECTION I: PAYMENT AND PERFORMANCE BOND ..... I-1

SECTION J: PREVAILING WAGE RATES ..... J-1

This Proposal, and Agreement have  
been prepared by:

**CITY ENGINEERING DIVISION  
CITY OF MADISON  
MADISON, DANE COUNTY, WISCONSIN**

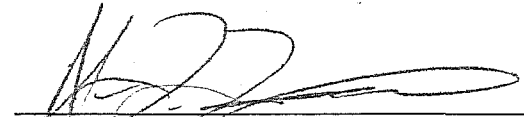
  
Alan Larson, P.E., Principal Engineer

12/10/14

## SECTION A: ADVERTISEMENT FOR BIDS AND INSTRUCTIONS TO BIDDERS

### REQUEST FOR BID FOR PUBLIC WORKS CONSTRUCTION CITY OF MADISON, WISCONSIN

#### A BEST VALUE CONTRACTING MUNICIPALITY

PROJECT NAME:	BOOSTER PUMP STATION 115 UPGRADE
CONTRACT NO.:	7411
SBE GOAL	6%
BID BOND	5%
PRE BID MEETING (1:00 P.M.)	1/2/15
PREQUALIFICATION APPLICATION DUE (1:00 P.M.)	1/2/15
BID SUBMISSION (1:00 P.M.)	1/9/15
BID OPEN (1:30 P.M.)	1/9/15
PUBLISHED IN WSJ	12/12/14, 12/19/14, 12/26/14 & 1/2/15

PRE BID MEETING: Representatives of the Affirmative Action Department will be present to discuss the Small Business Enterprise requirements at 1600 Emil Street, Madison Wisconsin.

PREQUALIFICATION APPLICATION: Forms are available on our website, [www.cityofmadison.com/business/pw/forms.cfm](http://www.cityofmadison.com/business/pw/forms.cfm). If not currently prequalified in the categories listed in Section A, an amendment to your Prequalification will need to be submitted prior to the same due date. Postmark is not applicable.

BIDS TO BE SUBMITTED by hand to 1600 EMIL ST., MADISON, WI 53713 or online at [www.bidexpress.com](http://www.bidexpress.com).

THE BID OPENING is at 1600 EMIL ST., MADISON, WI53713.

#### STANDARD SPECIFICATIONS

The City of Madison's Standard Specifications for Public Works Construction - 2014 Edition, as supplemented and amended from time to time, forms a part of these contract documents as if attached hereto.

These standard specifications are available on the City of Madison Public Works website, [www.cityofmadison.com/Business/PW/specs.cfm](http://www.cityofmadison.com/Business/PW/specs.cfm).

The Contractor shall review these Specifications prior to preparation of proposals for the work to be done under this contract, with specific attention to Article 102, "BIDDING REQUIREMENTS AND CONDITIONS" and Article 103, "AWARD AND EXECUTION OF THE CONTRACT." For the convenience of the bidder, below are highlights of three subsections of the specifications.

#### SECTION 102.1: PRE-QUALIFICATION OF BIDDERS

In accordance with Wisconsin State Statutes 66.0901 (2) and (3), all bidders must submit to the Board of Public Works proof of responsibility on forms furnished by the City. The City requires that all bidders be qualified on a biennial basis.

Bidders must present satisfactory evidence that they have been regularly engaged in the type of work specified herein and they are fully prepared with necessary capital, materials, machinery and supervisory personnel to conduct the work to be contracted for to the satisfaction of the City. All bidders must be pre-

qualified by the Board of Public Works for the type of construction on which they are bidding prior to the opening of the bid.

In accordance with Section 39.02(9)(a). of the General Ordinances, all bidders shall submit in writing to the Affirmative Action Division Manager of the City of Madison, a Certificate of Compliance or an Affirmative Action Plan at the same time or prior to the submission of the proof of responsibility forms.

The bidder shall be disqualified if the bidder fails to or refuses to, prior to opening of the bid, submit a Certificate of compliance, Affirmative Action Plan or Affirmative Action Data Update, as applicable, as defined by Section 39.02 of the General Ordinances (entitled Affirmative Action) and as required by Section 102.11 of the Standard Specifications.

#### SECTION 102.4 PROPOSAL

No bid will be accepted that does not contain an adequate or reasonable price for each and every item named in the Schedule of Unit Prices.

A lump sum bid for the work in accordance with the plans and specifications is required. The lump sum bid must be the same as the total amounts bid for the various items and it shall be inserted in the space provided.

All papers bound with or attached to the proposal form are considered a part thereof and must not be detached or altered when the proposal is submitted. The plans, specifications and other documents designated in the proposal form will be considered a part of the proposal whether attached or not.

A proposal submitted by an individual shall be signed by the bidder or by a duly authorized agent. A proposal submitted by a partnership shall be signed by a member/partner or by a duly authorized agent thereof. A proposal submitted by a corporation shall be signed by an authorized officer or duly authorized registered agent of such corporation, and the proposal shall show the name of the State under the laws of which such corporation was chartered. The required signatures shall in all cases appear in the space provided thereof on the proposal.

Each proposal shall be placed, together with the proposal guaranty, in a sealed envelope, so marked as to indicate name of project, the contract number or option to which it applies, and the name and address of the Contractor or submitted electronically through Bid Express ([www.bidexpress.com](http://www.bidexpress.com)). Proposals will be accepted at the location, the time and the date designated in the advertisement. Proposals received after the time and date designated will be returned to the bidder unopened.

The Bidder shall execute the Disclosure of Ownership form. REFER TO SECTION F.

#### SECTION 102.5: BID DEPOSIT (PROPOSAL GUARANTY)

All bids, sealed or electronic, must be accompanied with a Bid Bond equal to at least 5% of the bid or a Certificate of Annual/Biennial Bid Bond or certified check, payable to the City Treasurer. Bid deposit of the successful bidders shall be returned within forty-eight (48) hours following execution of the contract and bond as required.

#### PREVAILING WAGE RATES

Prevailing Wage Rates may be required and are attached in Section J of the contract. See Special Provisions to determine applicability.



**Bidders for this Contract(s) must be Pre-Qualified for at least one of the following type(s) of construction denoted by an**

**Building Demolition**

- 101  Asbestos Removal
- 120  House Mover

- 110  Building Demolition

**Street, Utility and Site Construction**

- 201  Asphalt Paving
- 205  Blasting
- 210  Boring/Pipe Jacking
- 215  Concrete Paving
- 220  Con. Sidewalk/Curb & Gutter/Misc. Flat Work
- 221  Concrete Bases and Other Concrete Work
- 222  Concrete Removal
- 225  Dredging
- 230  Fencing
- 235  Fiber Optic Cable/Conduit Installation
- 240  Grading and Earthwork
- 241  Horizontal Saw Cutting of Sidewalk
- 242  Infrared Seamless Patching
- 245  Landscaping, Maintenance
- 250  Landscaping, Site and Street
- 251  Parking Ramp Maintenance
- 252  Pavement Marking
- 255  Pavement Sealcoating and Crack Sealing
- 260  Petroleum Above/Below Ground Storage Tank Removal/Installation
- 262  Playground Installer
- 265  Retaining Walls, Precast Modular Units

- 270  Retaining Walls, Reinforced Concrete
- 275  Sanitary, Storm Sewer and Water Main Construction
- 276  Sawcutting
- 280  Sewer Lateral Drain Cleaning/Internal TV Insp.
- 285  Sewer Lining
- 290  Sewer Pipe Bursting
- 295  Soil Borings
- 300  Soil Nailing
- 305  Storm & Sanitary Sewer Laterals & Water Svc.
- 310  Street Construction
- 315  Street Lighting
- 318  Tennis Court Resurfacing
- 320  Traffic Signals
- 325  Traffic Signing & Marking
- 332  Tree pruning/removal
- 333  Tree, pesticide treatment of
- 335  Trucking
- 340  Utility Transmission Lines including Natural Gas, Electrical & Communications
- 399  Other \_\_\_\_\_

**Bridge Construction**

- 501  Bridge Construction and/or Repair

**Building Construction**

- 401  Floor Covering (including carpet, ceramic tile installation, rubber, VCT)
- 402  Building Automation Systems
- 403  Concrete
- 404  Doors and Windows
- 405  Electrical - Power, Lighting & Communications
- 410  Elevator - Lifts
- 412  Fire Suppression
- 413  Furnishings - Furniture and Window Treatments
- 415  General Building Construction, Equal or Less than \$250,000
- 420  General Building Construction, \$250,000 to \$1,500,000
- 425  General Building Construction, Over \$1,500,000
- 428  Glass and/or Glazing
- 429  Hazardous Material Removal
- 430  Heating, Ventilating and Air Conditioning (HVAC)
- 433  Insulation - Thermal
- 435  Masonry/Tuck pointing

- 437  Metals
- 440  Painting and Wallcovering
- 445  Plumbing
- 450  Pump Repair
- 455  Pump Systems
- 460  Roofing and Moisture Protection
- 464  Tower Crane Operator
- 461  Solar Photovoltaic/Hot Water Systems
- 465  Soil/Groundwater Remediation
- 466  Warning Sirens
- 470  Water Supply Elevated Tanks
- 475  Water Supply Wells
- 480  Wood, Plastics & Composites - Structural & Architectural
- 499  Other \_\_\_\_\_

**State of Wisconsin Certifications**

- 1  Class 5 Blaster - Blasting Operations and Activities 2500 feet and closer to inhabited buildings for quarries, open pits and road cuts.
- 2  Class 6 Blaster - Blasting Operations and Activities 2500 feet and closer to inhabited buildings for trenches, site excavations, basements, underwater demolition, underground excavations, or structures 15 feet or less in height.
- 3  Class 7 Blaster - Blasting Operations and Activities for structures greater than 15' in height, bridges, towers, and any of the objects or purposes listed as "Class 5 Blaster or Class 6 Blaster".
- 4  Petroleum Above/Below Ground Storage Tank Removal and Installation (Attach copies of State Certifications.)
- 5  Hazardous Material Removal (Contractor to be certified for asbestos and lead abatement per the Wisconsin Department of Health Services, Asbestos and Lead Section (A&LS).) See the following link for application: [www.dhs.wisconsin.gov/Asbestos/Cert](http://www.dhs.wisconsin.gov/Asbestos/Cert). State of Wisconsin Performance of Asbestos Abatement Certificate must be attached.
- 6  Certification number as a Certified Arborist or Certified Tree Worker as administered by the International Society of Arboriculture
- 7  Pesticide application (Certification for Commercial Applicator For Hire with the certification in the category of turf and landscape (3.0) and possess a current license issued by the DATCP)
- 8  State of Wisconsin Master Plumbers License.

## SECTION B: PROPOSAL

Please refer to the  
Bid Express Website  
at <https://bidexpress.com>  
look up contract number  
and go to  
Section B: Proposal Page

You can access all City of Madison bid solicitations for FREE at [www.bidexpress.com](http://www.bidexpress.com)

Click on the "Register for Free" button and follow the instructions to register your company and yourself. You will be asked for a payment subscription preference, since you may wish to bid online someday. Simply choose the method to pay on a 'per bid' basis. This requires no payment until / unless you actually bid online. You can also choose the monthly subscription plan at this time. You will, however, be asked to provide payment information. Remember, you can change your preference at anytime. You will then be able to complete your free registration and have full access to the site. Your free access does not require completion of the 'Digital ID' process, so you will have instant access for viewing and downloading. To be prepared in case you ever do wish to bid online, you may wish to establish your digital ID also, since you cannot bid without a Digital ID.

If you have any problems with the free registration process, you can call the bidexpress help team, toll free at 1-888-352-2439 (option 1, option1).

## SECTION C: SMALL BUSINESS ENTERPRISE

### Instructions to Bidders City of Madison SBE Program Information

#### 2 Small Business Enterprise (SBE) Program Information

##### 2.1 Policy and Goal

The City of Madison reaffirms its policy of nondiscrimination in the conduct of City business by maintaining a procurement process which remains open to all who have the potential and ability to sell goods and services to the City. It is the policy of the City of Madison to allow Small Business Enterprises (SBE) maximum feasible opportunity to participate in City of Madison contracting. The bidder acknowledges that its bid has been submitted in accordance with the SBE program and is for the public's protection and welfare.

Please refer to the "ADVERTISEMENT FOR BIDS" for the goal for the utilization of SBEs on this project. SBEs may participate as subcontractors, vendors and/or suppliers, which provide a commercially useful function. The dollar value for SBE suppliers or 'materials only' vendors shall be discounted to 60% for purposes of meeting SBE goals.

A bidder which achieves or exceeds the SBE goal will be in compliance with the SBE requirements of this project. In the event that the bidder is unable to achieve the SBE goal, the bidder must demonstrate that a good faith effort to do so was made. Failure to either achieve the goal or demonstrate a good faith effort to do so will be grounds for the bidder being deemed a non-responsible contractor ineligible for award of this contract.

A bidder may count towards its attainment of the SBE goal only those expenditures to SBEs that perform a commercially useful function. For purposes of evaluating a bidder's responsiveness to the attainment of the SBE goal, the contract participation by an SBE is based on the percentage of the total base bid proposed by the Contractor. The total base bid price is inclusive of all addenda.

Work performed by an SBE firm in a particular transaction can be counted toward the goal only if it involves a commercially useful function. That is, in light of industry practices and other relevant considerations, does the SBE firm have a necessary and useful role in the transaction, of a kind for which there is a market outside the context of the SBE Program, or is the firm's role a superfluous step added in an attempt to obtain credit towards goals? If, in the judgment of the Affirmative Action Division, the SBE firm will not perform a commercially useful function in the transaction, no credit towards goals will be awarded.

The question of whether a firm is performing a commercially useful function is completely separate from the question of whether the firm is an eligible SBE. A firm is eligible if it meets the definitional criteria and ownership and control requirements, as set forth in the City of Madison's SBE Program.

If the City of Madison determines that the SBE firm is performing a commercially useful function, then the City of Madison must then decide what that function is. If the commercially useful function is that of an SBE vendor / supplier that regularly transacts business with the respective product, then the City of Madison will count 60% of the value of the product supplied toward SBE goals.

To be counted, the SBE vendor / supplier must be engaged in selling the product in question to the public. This is important in distinguishing an SBE vendor / supplier, which has a regular trade with a variety of customers, from a firm which performs supplier-like functions on an ad hoc basis or for only one or two contractors with whom it has a special relationship.

A supplier of bulk goods may qualify as an eligible SBE vendor / supplier if it either maintains an inventory or owns or operates distribution equipment. With respect to the distribution equipment; e.g., a fleet of trucks, the term "operates" is intended to cover a situation in which the supplier leases the equipment on a regular basis for its entire business. It is not intended to cover a situation in which the firm simply provides drivers for trucks owned or leased by another party; e.g., a prime contractor, or leases such a party's trucks on an ad hoc basis for a specific job.

If the commercially useful function being performed is not that of a qualified SBE vendor / supplier, but rather that of delivery of products, obtaining bonding or insurance, procurement of personnel, acting as a broker or manufacturer's representative in the procurement of supplies, facilities, or materials, etc., only the fees or commissions will apply towards the goal.

For example, a business that simply transfers title of a product from manufacturer to ultimate purchaser; e. g., a sales representative who re-invoices a steel product from the steel company to the Contractor, or a firm that puts a product into a container for delivery would not be considered a qualified SBE vendor / supplier. The Contractor would not receive credit based on a percentage of the cost of the product for working with such firms.

Concerning the use of services that help the Contractor obtain needed supplies, personnel, materials or equipment to perform a contract: only the fee received by the service provider will be counted toward the goal. For example, use of a SBE sales representative or distributor for a steel company, if performing a commercially useful function at all, would entitle the Contractor receiving the steel to count only the fee paid to the representative or distributor toward the goal. This provision would also govern fees for professional and other services obtained expressly and solely to perform work relating to a specific contract.

Concerning transportation or delivery services: if an SBE trucking company picks up a product from a manufacturer or a qualified vendor / supplier and delivers the product to the Contractor, the commercially useful function it is performing is not that of a supplier, but simply that of a transporter of goods. Unless the trucking company is itself the manufacturer or a qualified vendor / supplier in the product, credit cannot be given based on a percentage of the cost of the product. Rather, credit would be allowed for the cost of the transportation service.

The City is aware that the rule's language does not explicitly mention every kind of business that may contribute work on this project. In administering these programs, the City would, on a case-by-case basis, determine the appropriate counting formula to apply in a particular situation.

## **2.2 Contract Compliance**

Questions concerning the SBE Program shall be directed to the Contract Compliance Officer of the City of Madison Department of Civil Rights, Affirmative Action Division, 210 Martin Luther King, Jr. Blvd., Room 523, Madison, WI 53703; telephone (608) 266-4910.

## 2.3 Certification of SBE by City of Madison

The Affirmative Action Division maintains a directory of SBEs which are currently certified as such by the City of Madison. Contact the Contract Compliance Officer as indicated in Section 2.2 to receive a copy of the SBE Directory or you may access the SBE Directory online at [www.cityofmadison.com/dcr/aaTBDir.cfm](http://www.cityofmadison.com/dcr/aaTBDir.cfm).

All contractors, subcontractors, vendors and suppliers seeking SBE status must complete and submit the **Targeted Business Certification Application** to the City of Madison Affirmative Action Division by the time and date established for receipt of bids. A copy of the Targeted Business Certification Application is available by contacting the Contract Compliance Officer at the address and telephone indicated in Section 2.2 or you may access the Targeted Business Certification Application online at [www.cityofmadison.com/dcr/aaTBDir.cfm](http://www.cityofmadison.com/dcr/aaTBDir.cfm). Submittal of the Targeted Business Certification Application by the time specified does not guarantee that the applicant will be certified as a SBE eligible to be utilized towards meeting the SBE goal for this project.

## 2.4 Small Business Enterprise Compliance Report

### 2.4.1 Good Faith Efforts

Bidders shall take all necessary affirmative steps to assure that SBEs are utilized when possible and that the established SBE goal for this project is achieved. A contractor who self performs a portion of the work, and is pre-qualified to perform that category of work, may subcontract that portion of the work, but shall not be required to do so. When a bidder is unable to achieve the established SBE goal, the bidder must demonstrate that a good faith effort to do so was made. Such a good faith effort should include the following:

- 2.4.1.1 Attendance at the pre-bid meeting.
- 2.4.1.2 Using the City of Madison's directory of certified SBEs to identify SBEs from which to solicit bids.
- 2.4.1.3 Assuring that SBEs are solicited whenever they are potential sources.
- 2.4.1.4 Referring prospective SBEs to the City of Madison Affirmative Action Division for certification.
- 2.4.1.5 Dividing total project requirements into smaller tasks and/or quantities, where economically feasible, to permit maximum feasible SBE participation.
- 2.4.1.6 Establishing delivery schedules, where requirements permit, which will encourage participation by SBEs.
- 2.4.1.7 Providing SBEs with specific information regarding the work to be performed.
- 2.4.1.8 Contacting SBEs in advance of the deadline to allow such businesses sufficient time to prepare a bid.
- 2.4.1.9 Utilizing the bid of a qualified and competent SBE when the bid of such a business is deemed reasonable (i.e. 5% above the lowest bidder), although not necessarily low.
- 2.4.1.10 Contacting SBEs which submit a bid, to inquire about the details of the bid and confirm that the scope of the work was interpreted as intended.

### 2.4.2 Reporting SBE Utilization and Good Faith Efforts

The Small Business Enterprise Compliance Report is to be submitted by the bidder with the bid: This report is due by the specified bid closing time and date. Bids submitted without a completed SBE Compliance Report as outlined below

shall be deemed non-responsible and the bidder ineligible for award of this contract.

2.4.2.1 If the Bidder meets or exceeds the goal established for SBE utilization, the Small Business Enterprise Compliance Report shall consist of the following:

2.4.2.1.1 **Cover Page**, Page C-6; and

2.4.2.1.2 **Summary Sheet**, C-7.

2.4.2.2 If the bidder does not meet the goal established for SBE utilization, the Small Business Enterprise Compliance Report shall consist of the following:

2.4.2.2.1 **Cover Page**, Page C-6;

2.4.2.2.2 **Summary Sheet**, C-7; and

2.4.2.2.3 **SBE Contact Report**, C-8 and C-9. (A separate Contact Report must be completed for each applicable SBE which is not utilized.)

## 2.5 Appeal Procedure

A bidder which does not achieve the established goal and is deemed non-responsible for failure to demonstrate a good faith effort to achieve such goal and subsequently denied eligibility for award of contract may, within 72 hours of receiving such notification, appeal that decision to a special appeals committee composed of three (3) members of the Affirmative Action Commission, three (3) members of the Board of Public Works and a seventh member appointed by the Mayor. All appeals must be made in writing to the City Engineer and received within 72 hours of City of Madison's notice. Postmark not applicable.

## 2.6 SBE Requirements After Award of the Contract

The successful bidder shall identify SBE subcontractors, suppliers and vendors on the subcontractor list in accordance with the specifications. The Contractor shall submit a detailed explanation of any variances between the listing of SBE subcontractors, vendors and/or suppliers on the subcontractor list and the Contractor's SBE Compliance Report for SBE participation.

No change in SBE subcontractors, vendors and/or suppliers from those SBEs indicated in the SBE Compliance Report will be allowed without prior approval from the Engineer and the Affirmative Action Division. The contractor shall submit in writing to the City of Madison Affirmative Action Division a request to change any SBE citing specific reasons which necessitate such a change. The Affirmative Action Division will use a general test of reasonableness in approving or rejecting the contractor's request for change. If the request is approved, the Contractor will make every effort to utilize another SBE if available.

The City will monitor the project to ensure that the actual percentage commitment to SBE firms is carried out.

## 2.7 SBE Definition and Eligibility Guidelines

A Small Business Enterprise is a business concern awarded certification by the City of Madison. For the purposes of this program a Small Business Enterprise is defined as:

- A. An independent business operated under a single management. The business may not be a subsidiary of any other business and the stock or ownership may not be held by any individual or any business operating in the same or a similar field. In determining whether an entity qualifies as a SBE, the City shall consider all factors relevant to being an independent business including, but not limited to, the date the business was established, adequacy of its resources for the work in which it proposes to involve itself, the degree to which financial, equipment leasing and other relationships exist with other ineligible firms in the same or similar lines of work. SBE owner(s) shall enjoy the customary incidents of ownership and shall share in the risks and profits commensurate with their enjoyment interests, as demonstrated by an examination of the substance rather than form or arrangements that may be reflected in its ownership documents.
- B. A business that has averaged no more than \$4.0 million in annual gross receipts over the prior three year period and the principal owner(s) do not have a personal net worth in excess of \$1.32 million.

Firm and/or individuals that submit fraudulent documents/testimony may be barred from doing business with the City and/or forfeit existing contracts.

SBE certification is valid for one (1) year unless revoked.

## SECTION D: SPECIAL PROVISIONS

### BOOSTER PUMP STATION 115 UPGRADE CONTRACT NO. 7411

It is the intent of these Special Provisions to set forth the final contractual intent as to the matter involved and shall prevail over the Standard Specifications and plans whenever in conflict therewith. In order that comparisons between the Special Provisions can be readily made, the numbering system for the Special Provisions is equivalent to that of the Specifications.

Whenever in these Specifications the term "Standard Specifications" appears, it shall be taken to refer to the City of Madison Standard Specifications for Public Works Construction and Supplements thereto.

#### SECTION 102.4: **PROPOSAL**

An alternative bid is requested as indicated on the bid form which will ADD to the lump sum base bid amount. The lump sum base bid amount (without consideration of the alternative bid) will be utilized in determining the lowest responsible and responsive bidder.

#### SECTION 102.10: **PREVAILING WAGE**

For this project, payment of prevailing wages (white sheet) shall be required unless the box indicating prevailing wages are not required is checked below.

Prevailing wages shall not be required when this box is checked.

If prevailing wages (white sheet) are required, the wages and benefits paid on the contract shall not be less than those specified in the Prevailing Wage Determination included with these contract documents for the following types of work:

- Building and Heavy Construction
- Sewer, Water, and Tunnel Construction
- Local Street and Miscellaneous Paving Construction
- Residential and Agricultural Construction

When multiple boxes are checked, worker's wages may vary according to the type and area of work performed. It is the responsibility of the Contractor to determine and apply the appropriate wage rate for the specific work assigned.

#### SECTION 102.12: **BEST VALUE CONTRACTING**

This contract shall be considered a Best Value Contract if the Contractor's bid is equal to or greater than \$55,500 for a single trade contract; or equal to or greater than \$271,500 for a multi-trade contract pursuant to MGO 33.07(7).



**MADISON WATER UTILITY  
UPGRADE OF BOOSTER PUMPING  
STATION 115**

**TECHNICAL SPECIFICATIONS**

Baxter & Woodman, Inc.  
Crystal Lake, IL  
815.459.1260

Chicago, IL  
773.444.0292

DeKalb, IL  
815.787.3111

Grayslake, IL  
847.223.5088

Mokena, IL  
708.478.2090

Burlington, WI  
262.763.7834

Madison, WI  
608.277.1230

**PROJECT TITLE PAGE  
00 01 01 (140218.40)**

00 01 07

SEALS PAGE

Dated 12/10, 2014

1. Specifications of materials and labor required for the construction work shown on the Drawings are prepared by Baxter & Woodman, Inc., Consulting Engineers.
2. The Drawings which accompanies these Specifications are titled "Madison Water Utility, Madison, Wisconsin, Upgrade of Booster Pumping Station 115".
3. Copyright 2014 by Baxter & Woodman, Inc. All Rights Reserved. No part of these Specifications or the accompanying Drawings may be reproduced by any means, or otherwise reused without the prior written permission of Baxter & Woodman, Inc.



*Gerald D. Groth*

Project Engineer  
License Expires 7/31/2016

BAXTER & WOODMAN, INC.  
STATE OF WISCONSIN – PROFESSIONAL DESIGN FIRM  
LICENSE NO. – 484-001 - EXPIRES 1/31/2016

**MADISON WATER UTILITY  
UPGRADE OF BOOSTER STATION 115  
TECHNICAL SPECIFICATIONS**

**TABLE OF CONTENTS**

<u>Section Number</u>	<u>Section</u>
<u>DIVISION 00</u>	- PROCUREMENT AND CONTRACTING REQUIREMENTS
00 01 01	PROJECT TITLE PAGE
00 01 07	SEALS PAGE
00 01 10	TABLE OF CONTENTS
00 73 00.13	SUPPLEMENTARY CONDITIONS
<u>DIVISION 01</u>	- GENERAL REQUIREMENTS
01 14 11	CONTRACTOR USE OF PREMISES
01 14 15	PLANT OPERATION DURING CONSTRUCTION
01 26 13	REQUESTS FOR INTERPRETATION
01 26 13.13	RFI FORM
01 31 14	PROJECT COORDINATION AND CONSTRUCTION PHASING
01 31 19	PROJECT MEETINGS
01 32 16	CONSTRUCTION PROGRESS SCHEDULE
01 33 01	SUBMITTALS
01 41 26	PERMITS
01 42 13	ABBREVIATIONS AND ACRONYMS
01 50 00	TEMPORARY FACILITIES AND CONTROLS
01 61 01	GENERAL EQUIPMENT REQUIREMENTS
01 62 01	PRODUCT OPTIONS AND SUBSTITUTIONS
01 66 11	STORAGE AND PROTECTION OF MATERIAL AND EQUIPMENT
01 73 29	CUTTING AND PATCHING
01 74 23	FINAL CLEANING
01 77 01	CONTRACT CLOSEOUT
01 78 26	OPERATION AND MAINTENANCE MANUAL
01 78 39	PROJECT RECORD DOCUMENTS
01 91 58	FACILITY STARTUP
<u>DIVISION 02</u>	- EXISTING CONDITIONS
02 41 53	DEMOLITION, REMOVAL AND ABANDONMENT
<u>DIVISION 03</u>	- CONCRETE
03 30 00	CAST-IN-PLACE CONCRETE
03 48 00	PRECAST CONCRETE SPECIALTIES

Table of Contents - continued

<u>Section Number</u>	<u>Section</u>
<u>DIVISION 04</u>	- MASONRY
04 20 00	UNIT MASONRY
<u>DIVISION 05</u>	- METALS
05 50 00	METAL FABRICATIONS
<u>DIVISION 07</u>	- THERMAL AND MOISTURE PROTECTION
07 92 00	JOINT SEALANTS
<u>DIVISION 09</u>	- FINISHES
09 90 00	PAINTING AND COATING
<u>DIVISION 22</u>	- PLUMBING
22 05 53	IDENTIFICATION FOR PLUMBING PIPING AND EQUIPMENT
22 11 23.63	MAGNETIC DRIVE PUMPS
22 19 13	PIPE AND PIPE FITTINGS
22 19 23	VALVES
22 19 26	GAUGES
22 19 33	PIPE INSULATION
22 19 43	PLUMBING AND FIXTURES
<u>DIVISION 26</u>	- ELECTRICAL
26 05 19	LOW-VOLTAGE ELECTRICAL POWER CONDUCTORS AND CABLES
26 05 23	CONTROL-VOLTAGE ELECTRICAL POWER CABLES
26 05 26	GROUNDING AND BONDING OF ELECTRICAL SYSTEMS
26 05 29	HANGERS AND SUPPORTS FOR ELECTRICAL SYSTEMS
26 05 33	RACEWAY AND BOXES FOR ELECTRICAL SYSTEMS
26 05 53	IDENTIFICATION FOR ELECTRICAL SYSTEMS
26 09 13	ELECTRICAL POWER MONITORING AND CONTROL
26 09 95	PUSHBUTTONS, SELECTOR SWITCHES, AND PILOT LIGHTS
26 22 13	LOW VOLTAGE DISTRIBUTION TRANSFORMERS
26 24 16	PANELBOARDS
26 24 19	MOTOR-CONTROL CENTERS
26 27 26	WIRING DEVICES
26 28 00	LOW-VOLTAGE CIRCUIT PROTECTIVE DEVICES
26 28 16	ENCLOSED SWITCHES AND CIRCUIT BREAKERS
26 29 13.16	REDUCED-VOLTAGE MOTOR CONTROLLERS
26 29 23	VARIABLE-FREQUENCY MOTOR CONTROLLERS
26 32 13.33	DIESEL FUELED ENGINE-GENERATORS

Table of Contents - continued

<u>Section Number</u>	<u>Section</u>
<u>DIVISION 26</u>	- ELECTRICAL continued
26 36 00	TRANSFER SWITCHES
26 43 00	TRANSIENT VOLTAGE SUPPRESSION
26 60 20	ELECTRICAL SERVICE
<u>DIVISION 31</u>	- EARTHWORK
31 16 00	SITE PREPARATION
31 22 22	EARTHWORK FOR ROADS, DRIVEWAYS, AND WALKS
31 23 39	EXCAVATING, BACKFILLING, AND COMPACTING
31 23 79	TRENCHING, BACKFILLING, AND COMPACTING
31 25 00	SOIL EROSION AND SEDIMENT CONTROLS
<u>DIVISION 32</u>	- EXTERIOR IMPROVEMENTS
32 10 00.13	ROADS, DRIVEWAYS, AND WALKS
32 31 13	FENCES AND GATES
32 92 00.13	LAWNS AND GRASSES
<u>DIVISION 40</u>	- PROCESS INTEGRATION
40 90 10	PROCESS CONTROL SYSTEM FOR WATER TREATMENT EQUIPMENT
40 91 10	PROCESS INSTRUMENTATION AND CONTROL SCHEDULE
40 91 13.16	CHLORINE PROCESS MEASUREMENT DEVICES
40 91 19.29	LIQUID PRESSURE PROCESS MEASUREMENT DEVICES
40 91 23.33	FLOW PROCESS MEASUREMENT DEVICES
40 91 23.36	LEVEL PROCESS MEASUREMENT DEVICES
40 94 27	DISTRIBUTED INPUT/OUTPUT (DIO) DEVICES
40 94 33	HUMAN-MACHINE INTERFACES
40 94 43	PROGRAMMABLE LOGIC PROCESS CONTROLLERS
40 95 13	PROCESS CONTROL PANELS AND HARDWARE
40 95 70	PROCESS CONTROL SURGE PROTECTORS
40 95 74	PROCESS CONTROL SIGNAL CONDITIONERS/CONVERTERS
40 95 88	POWER SUPPLY SYSTEMS
40 95 92	RELAYS
40 97 96	PROCESS SWITCHES
<u>DIVISION 44</u>	- POLLUTION CONTROL AND WATER TREATMENT EQUIPMENT
44 42 56.13	WATER BOOSTER PUMPING EQUIPMENT INSTALLATION

00 73 00.13

## SUPPLEMENTARY CONDITIONS

## PART 1 - GENERAL

## 1.1 SUPPLEMENTARY CONDITIONS

- A. These Supplementary Conditions add to but do not subtract from the General Conditions required by the City of Madison.

These Supplementary Conditions, as noted below; modify, change, delete from or add to the "Standard General Conditions of the Construction Contract" EJCDC No. C-700, 2007 edition. Where any Article of the General Conditions is modified, or any Paragraph, Subparagraph, or Clause thereof is modified or deleted by these Supplementary Conditions, the unaltered provisions of that Article, Paragraph, Subparagraph, or Clause shall remain in effect.

The City of Madison and EJCDC General Conditions may be supplemented elsewhere in the Contract Documents by provisions located in, but not necessarily limited to Division 01 of these Technical Specifications.

## 1.2 ARTICLE 1 – DEFINITIONS AND TERMINOLOGY

- A. SC-1
1. The terms used in these Supplementary Conditions which are defined in the Standard General Conditions of the Construction Contract have the identical meaning assigned to them in said General Conditions.
- B. SC-(1.01A.17)
1. The term "Drawings" and the term "Plans" shall be considered synonymous whenever and wherever used in the Contract Documents.

## 1.3 ARTICLE 2 - PRELIMINARY MATTERS

- A. SC-2.02
1. Delete paragraph 2.02 in its entirety and substitute the following:  
  
2.02 "ENGINEER will provide an electronic copy of the Drawings and Project Manual to the Contractor at the Preconstruction Conference."
- C. SC-2.03
1. Under paragraph 2.03, delete the last sentence in its entirety.
- D. SC-2.05.A
1. Delete paragraph 2.05.A in its entirety.

SUPPLEMENTARY CONDITIONS

00 73 00.13-1 (140218.40)

- E. SC-2.05.A.1 through 2.05.A.3
  - 1. Delete paragraphs 2.05.A.1 through 2.05.A.3 inclusive in their entirety.
  
- F. SC-2.06
  - 1. Under paragraph 2.06, add "Owner" to the listing of preconstruction conference attendees.
  
  - 2. Under paragraph 2.06, change "paragraph 2.05.A " to "paragraph 2.07".
  
- G. SC-2.07
  - 1. Delete paragraph 2.07 in its entirety and substitute the following:
    - 2.07 Prior to submission of the first Application for Payment, but no later than 30 calendar days after Contract Times commence, Contractor shall submit to Engineer for review and approval:
      - A. A progress schedule indicating the times (numbers of days or dates) for starting and completing the various stages of the Work, including any Milestones specified in the Contract Documents;
  
      - B. A schedule of Shop Drawings and Sample submittal which will list each required submittal and the times for submitting, reviewing, and processing such submittal;
  
      - C. A schedule of values for all of the Work which will include quantities and prices of items aggregating the Contract Price and will subdivide the Work into component parts in sufficient detail to serve as the basis for progress payments during construction. Such prices will include an appropriate amount of overhead and profit applicable to each item of Work; and
  
      - D. A schedule of progress payments Contractor anticipates will be earned during the course of the Work.

No progress payment shall be made to Contractor until the schedules are submitted to and acceptable to Engineer as provided below. The progress schedule will be acceptable to Engineer as providing an orderly progression of the Work to completion within any specified Milestones and the Contract Times, but such acceptance will neither impose on Engineer responsibility for the sequencing, scheduling or progress of the Work nor interfere with or relieve Contractor from Contractor's full responsibility therefor. Contractor's schedule of Shop Drawing and Sample submissions will be acceptable to Engineer as providing a workable arrangement for reviewing and processing the required submittals. Contractor's schedule of values will be acceptable to Engineer as to form and substance.

1.4 ARTICLE 4 - AVAILABILITY OF LANDS; SUBSURFACE AND PHYSICAL CONDITIONS;  
REFERENCE POINTS

- A. SC-4.01.A
  - 1. Under paragraph 4.01.A, third sentence, insert the words "and temporary construction easements shown on the Drawings" after the word "facilities".

- B. SC-4.02.A
  - 1. Under paragraph 4.02.A, change "The Supplementary Conditions" to "Section 00 31 32.11 Subsurface Drilling Information or Section 00 31 32.13 Subsurface Drilling and Sampling Information."
- C. SC-4.02.B
  - 1. Under paragraph 4.02.B, delete the second sentence "Such technical data is identified in the Supplementary Conditions".
- D. SC-4.05.A
  - 1. Under paragraph 4.05.A., delete first sentence and substitute the following:
    - A. Owner shall provide land surveys necessary to establish right-of-way, easements and property lines. Engineer will provide base lines, bench marks and reference points which in Engineer's judgment are necessary to enable Contractor to proceed with the Work. Contractor shall provide all stakes, markers, labor and assistance required by Engineer.
  - 2. Under paragraph 4.05.A, last sentence, insert the words "and pay" between the words "responsible" and "for".

1.5 ARTICLE 6 - CONTRACTOR'S RESPONSIBILITIES

- A. SC-6.02.B
  - 1. Under paragraph 6.02.B, add: The regular working hours are between 7:00 AM and 5:00 PM, Monday through Friday. In the event Contractor works more than eight hours on any weekday, or works anytime on Saturdays, Sundays, or holidays, during which time the Engineer, Resident Project Representative, or assistants are required to be present, Owner shall pay the cost for such overtime engineering services and shall deduct such cost from payments due Contractor. Overtime engineering services shall be charged at Engineer's standard hourly rates applied on a time and one-half basis for all time over eight hours on any single working day and for all hours on Saturday, and on a double time basis for all Sunday and holiday hours. If the amount due Contractor is not sufficient to cover the cost of overtime engineering services, Contractor shall reimburse Owner in the amount necessary to cover such costs. Legal holidays include:

New Years Day	Memorial Day
Independence Day	Labor Day
Thanksgiving Day	Christmas Day

If the legal holiday falls on Saturday, all hours worked on the preceding Friday and/or the Saturday will be considered as holiday hours. If the legal holiday falls on Sunday, all hours worked on the following Monday will be considered as holiday hours.

- B. SC-6.06.A
  - 1. Under paragraph 6.06.A, add: Any person employed by Contractor or Subcontractors who does not perform his work in a proper and skillful manner, or who is intemperate, disorderly, or otherwise objectionable, shall, at the written



request of Owner, be forthwith removed from the project site and shall not be employed again in any portion of the Work without written consent of Owner.

C. SC-6.06.B

1. Under paragraph 6.06.B, add: Contractor shall identify all Subcontractors, major Suppliers and other persons or organizations providing principal items of work, material, and equipment. Contractor shall within ten working days of the date on the Notice of Award identify and submit in writing to the Engineer for Owner acceptance the names, addresses, and telephone numbers of all Subcontractors, Major Suppliers, and other persons or organizations providing principal items of work, material, and equipment.

D. SC-6.19.A

1. Delete paragraph 6.19.A and 6.19.B in their entirety and substitute the following:

6.19.A Contractor shall execute and deliver to Owner, before the final payment will be issued, a written warranty which guarantees that all work is in accordance with the Contract Documents and will not be defective. This warranty shall guarantee all work for a period of three years from the date of acceptance of the Work and final payment by Owner, except for equipment, motors, electrical controls, and other mechanical devices which shall be guaranteed for a period of two years from the date of acceptance and use of each item of equipment by Owner unless a different guarantee period of time is specified under other parts of the Contract Documents.

If within these guarantee periods or such longer period of time as may be prescribed by the Contract Documents, any work is found to be defective, Contractor shall promptly, without cost to Owner and in accordance with Owner's written instructions, either correct such defective work, or, if it has been rejected by Owner, remove it from the site and replace it with non-defective work. If Contractor does not promptly comply with the terms of such instructions, or in an emergency where delay would cause serious risk of loss or damage, Owner may have the defective work corrected or the rejected work removed and replaced, and all direct and indirect costs of such repair and/or replacement of work, including compensation for additional professional services, shall be paid or reimbursed to Owner by Contractor.

Contractor shall furnish a warranty bond in an amount equal to five percent (5%) of the Contract Price, but not less than \$10,000, by a surety satisfactory to Owner to guarantee Contractor's warranty to repair or replace defective work. The warranty bond shall be in addition to Contractor's contract Performance-Payment Bond, and shall be delivered to Owner prior to final payment to Contractor for the Work. Contractor's warranty and guarantee hereunder excludes defects or damage caused by:

E. SC-6.20.C

1. Under paragraph 6.20.C, add: Except insofar as indemnification is sought by Engineer or Engineer's Consultants for litigation type expenses including, but not limited to, all fees and charges of engineers, architects, attorneys and other professionals and all court or arbitration or other dispute resolution costs.

1.6 ARTICLE 8 - OWNER'S RESPONSIBILITIES

- A. SC-8.06
  - 1. Delete paragraph 8.06 in its entirety.

1.7 ARTICLE 9 - ENGINEER'S STATUS DURING CONSTRUCTION

- A. SC-9.03
  - 1. Under the paragraph 9.03.A., delete the second sentence.
  - 2. Under paragraph 9.03A add the following:

A LISTING OF THE DUTIES, RESPONSIBILITIES AND LIMITATIONS OF AUTHORITY OF THE RESIDENT PROJECT REPRESENTATIVE (RPR).

**A. General**

RPR is Engineer's agent at the site, will act as directed by and under the supervision of Engineer, and will confer with Engineer regarding RPR's dealings in matters pertaining to the on-site work shall in general be with Engineer and Contractor keeping Owner advised as necessary. RPR's dealings with subcontractors will only be through or with the full knowledge and approval of Contractor. RPR shall generally communicate with Owner with the knowledge of and under the direction of Engineer.

**B. Duties and Responsibilities of RPR**

- 1. *Schedules:* Review the progress schedule, schedule of the Shop Drawing submittals and schedule of values prepared by Contractor and consult with Engineer concerning acceptability.
- 2. *Conferences and Meetings:* Attend meetings with Contractor, such as preconstruction conferences, progress meetings, job conferences and other project-related meetings, and prepare and circulate copies of minutes thereof.
- 3. *Liaison:*
  - a. Serve as Engineer's liaison with Contractor, working principally through Contractor's superintendent and assist in understanding the intent of the Contract Documents; and assist Engineer in serving as Owner's liaison with Contractor when Contractor's operations affect Owner's on-site operations.
  - b. Assist in obtaining from Owner additional details or information, when required for proper execution of the Work.
- 4. *Shop Drawings and Samples:*
  - a. Record date of receipt of Shop Drawings and samples.

- b. Receive samples which are furnished at the site by Contractor, and notify Engineer of availability of samples for examination.
  - c. Advise Engineer and Contractor of the commencement of any Work requiring a Shop Drawing or sample if the submittal has not been approved by Engineer.
5. *Review of Work, Rejection of Defective Work, Inspections and Tests:*
- a. Conduct on-site observations of the Work in progress to assist Engineer in determining if the Work is in general proceeding in accordance with the Contract Documents.
  - b. Report to Engineer whenever RPR believes that any Work is unsatisfactory, faulty or defective or does not conform to the Contract Documents, or has been damaged, or does not meet the requirements of any inspection, test or approval required to be made: and advise Engineer of Work that RPR believes should be corrected or rejected or uncovered for observation, or requires special testing, inspection and approval.
  - c. Verify that tests, equipment and systems startups and operating and maintenance training are conducted in the presence of appropriate personnel and that Contractor maintains adequate records thereof; and observe, record and report to Engineer appropriate details relative to the test procedures and startups.
  - d. Accompany visiting inspectors representing public or other agencies having jurisdiction over the Project, record the results of these inspections and report to Engineer.
6. *Interpretation of Contract Documents:* Report to Engineer when clarifications and interpretations of the Contract Documents are needed and transmit to Contractor clarifications and interpretations as issued by Engineer.
7. *Modifications:* Consider and evaluate Contractor's suggestions for modifications in Drawings or Specifications and report with RPR's recommendations to Engineer. Transmit to Contractor decisions as issued by Engineer.
8. *Records:*
- a. Maintain at the job site orderly files for correspondence, reports of job conference, Shop Drawings and samples, reproductions of original Contract Documents including all Work Directive Changes, Addenda, Change Orders, Field Orders, additional Drawings issued subsequent to the execution of the Contract, Engineer's clarifications and interpretations of the Contract Documents, progress reports, and other Project related documents.
  - b. Complete a Daily Report recording Contractor hours on the job site, weather conditions, data relative to questions or Work Directive Changes, Change Orders or changed conditions, list

- of job site visitors, daily activities, decisions, observations in general, and specific observations in more detail as in the case of observing test procedures; and send original to Engineer.
- c. Record names, address and telephone numbers of all Contractors, subcontractors and major suppliers of materials and equipment.
9. *Reports:*
- a. Furnish Engineer periodic reports as required of progress of the Work and the Contractor's compliance with the progress scheduled and schedule of Shop Drawings and sample submittals.
  - b. Consult with Engineer in advance of schedule major tests, inspections or start of important phases of the Work.
  - c. Draft Field Orders, obtain backup material from Contractor and recommend to Engineer Change Orders and Work Directive Changes. Furnish Engineer copies of all Field Orders.
  - d. Report immediately to Engineer and Owner upon occurrence of any accident.
10. *Payment Requests:* Review applications for payment with Contractor for compliance with the established procedure for their submission and forward with recommendations to Engineer, noting particularly the relationship of the payment requested to the schedule of values. Work completed and materials and equipment delivered at the site but not incorporated in the Work.
11. *Certificates, Operation and MAINTENANCE Manuals:* During the course of the Work, verify that certificates, operation and maintenance manuals and other data required to be assembled and furnished by Contractor are applicable to the items actually installed and in accordance with the Contract Documents, and have this material delivered to Engineer for review and forwarding to Owner prior to final payment for the Work.
12. *Completion:*
- a. Before Engineer issues a Certificate of Substantial Completion, prepare and furnish to the Engineer a list of observed items requiring completion or correction.
  - b. Conduct final inspection in the company of Engineer, Owner, and Contractor and prepare and furnish to the Engineer a final list of items to be completed or corrected.
  - c. Observe that all items on final list have been completed or corrected and make recommendations to Engineer concerning acceptance.

**C. Limitations of Authority**

Resident Project Representative:

1. Shall not authorize any deviation from the Contract Documents or substitution of materials or equipment, unless authorized by Engineer.
2. Shall not exceed limitations of Engineer's authority as set forth in the Agreement or the Contract Documents.
3. Shall not undertake any of the responsibilities of Contractor, subcontractors or Contractor's superintendent.
4. Shall not advise on, issue directions relative to or assume control over any aspect of the means, methods, techniques, sequences or procedures or construction unless such advice or directions are specifically required by the Contract Documents.
5. Shall not advise on, issue directions relative or assume control over safety precautions and programs in connection with the Work.
6. Shall not accept Shop Drawing or sample submittals from anyone other than Contractor.
7. Shall not authorize Owner to occupy the Project in whole or in part.
8. Shall not participate in specialized field or laboratory tests or inspections conducted by others except as specifically authorized by Engineer.

**1.8 ARTICLE 12 - CHANGE OF CONTRACT PRICE; CHANGE OF CONTRACT TIMES**

**A. SC-12.04 through 12.06**

1. Add the following paragraphs:

**12.04 Start and Completion Times**

The date of beginning and the time for completion of the Work are essential conditions of the Agreement and the Work required shall be commenced on a date specified in the Notice to Proceed.

**12.05 Time for Completion**

Contractor shall proceed with the Work at such rate of progress to insure full completion within the Contract Times. It is expressly understood and agreed, by and between the Contractor and the Owner, that the Contract Times for the completion of the Work described herein is a reasonable time, taking into consideration the adverse weather conditions for the season, or seasons, involved and other factors prevailing in the locality of the Work.

The Contract Substantial Completion date is July 1, 2015. The Contract Final Completion date is August 1, 2015.

12.06 Liquidated Damages

Contractor understands that time is of the essence and that Owner will suffer financial loss if the Work is not completed within the times or by the dates specified in the Bid Form, plus any extensions thereof allowed in accordance with Article 12 of the General Conditions. Contractor also recognizes the delays, expense, and difficulties involved in proving in a legal or arbitration proceeding the actual loss suffered by Owner if the Work is not completed on time. Accordingly, instead of requiring any such proof, Contractor shall pay Owner as liquidated damages for delay (but not as a penalty) the amount established by City of Madison General Conditions.

1.9 ARTICLE 13 - TESTS AND INSPECTIONS; CORRECTION, REMOVAL OR ACCEPTANCE OF DEFECTIVE WORK

A. SC-13.10

1. Add new paragraph 13.10 as follows:

13.10 Notification and Time Limit for Repairs:

- A. Contractor shall be responsible for the proper and safe protection of his work at all times during construction and also during the three-year guarantee period after the acceptance of the completed work by Owner. Contractor shall provide, erect, and maintain barricades, red flags, and torches and lights at all places where work is in progress, and wherever else required by Owner.
- B. Contractor shall maintain an emergency phone number where he/she can be notified at any time, Sundays and holidays included, of an emergency condition due to the work which requires immediate repair or protection. Upon such notification by Owner, Contractor shall be given a two-hour time limit to provide whatever barricades, flags, torches and lights are required to mark and protect the hazard. If Contractor fails to provide this protection within the two-hour period from time of notification, Owner will provide the necessary protection and deduct the sum of \$200.00 for each occurrence from the monies due and payable to Contractor for completed work.
- C. Also, upon notification by Owner, Contractor shall be given a 24-hour time limit to begin to make any repairs to the Work as deemed necessary by Owner. If Contractor fails to proceed with necessary repairs within the 24-hour notification period, Owner will make the necessary repairs to the Work and deduct the cost of labor and materials, including engineering costs, for each repair incident from the monies due and payable to Contractor for completed work.

## 1.10 ARTICLE 14 - PAYMENTS TO CONTRACTOR AND COMPLETION

## A. SC-14.01

1. Add the following paragraph after paragraph 14.01.A:

B. Contractor shall submit revisions to the initial schedule of progress payments whenever actual outlays for the Work vary beyond -5 percent and +10 percent from the schedule, as determined by Engineer.

## B. SC-14.02

1. Under paragraph 14.02.A.1, delete the remainder of the first sentence after "(but not more than one a month)" and insert the following:

Contractor shall submit to Engineer for review an original plus four duplicate copies of each Application for Payment and each copy shall be accompanied by a "Sworn Statement For Contractor And Subcontractor To Owner" on a pre-printed or computer generated form similar to Certificate 00 62 76.01.

2. Delete paragraph 14.02.A.3, and substitute the following:

Periodic partial payments shall be for the value of the completed work less a retained amount of 5 percent of the value of completed work as approved by Engineer until construction is 50 percent complete, after which no additional amount will be retained if Contractor is making progress to Owner's satisfaction and there is no specific cause for withholding 5 percent of the total value of completed work. At 50 percent completion or any time thereafter when the progress of the work is not satisfactory, additional amounts may be retained up to 10 percent of the value of the work completed. When the project is substantially complete and available for Owner's operational or beneficial occupancy, the retained amount shall be reduced to only that amount estimated by Engineer as necessary to assure completion of the Work. The final payment, including the retained amount, shall be payable within 30 days after the completion of the Work, approval by Engineer and acceptance by Owner. The acceptance of the final payment by Contractor shall be considered to be a waiver of all claims against Owner under the Agreement.

## C. SC-14.02.C

1. Under paragraph 14.02.C, change "Ten" to "Within 30".

## D. SC-14.03

1. Under paragraph 14.03.A, add the following:

B. Contractor shall procure from each Subcontractor and Supplier of material or labor a waiver of any claim which they may have under the mechanics lien laws of the state in which the Work is located, to insure Owner immunity from mechanics liens on account of anything which is done by Contractor or his Subcontractors in carrying out the Agreement and any work orders for additions thereto, all as a condition of any payment by Owner. Any payments made by Owner without requiring compliance with this paragraph shall not be construed as a waiver by Owner of the right to require compliance with this paragraph as a condition of later payments.

Contractor shall furnish with his final Application for Payment a complete release of all liens arising out of this contract, or receipts in full in lieu thereof and an affidavit that the releases and receipts include all labor and material for which a lien could be filed.

E. SC-14.07

1. Under paragraph 14.07.C, change "Thirty" to "Sixty".

1.11 ARTICLE 19 – PREVAILING WAGE RATES

A. SC-19.01 Prevailing Wage Rates

1. Contractor shall comply with the attached prevailing wage rates as determined by the State of Wisconsin Department of Workforce Development (DWD). If DWD finds a contractor violating the prevailing wage law DWD will assess liquidated damages of 100% of the wages owed to employees.
2. Contractor shall comply with all applicable federal, state, and local rules and regulations regarding the posting, certification, and filing of wage rates paid to employees. Contractor shall file certified payroll records with DWD on a monthly basis in a format that meets DWD reporting requirements. Certified payroll reports must be filed with DWD by the end of the first week following the month in which the work was conducted.
3. Upon completion of the Work and prior to final payment, Contractor shall file with Owner, the attached affidavit of compliance with prevailing wage rate determination.

END OF SUPPLEMENTARY CONDITIONS



SECTION 01 14 11

CONTRACTOR USE OF PREMISES

PART 1 - GENERAL

1.1 SUMMARY

- A. This Section applies to all situations in which the Contractor or his representatives including, but not necessarily limited to, suppliers, subcontractors, employees, and field engineers, enter upon the Owner's property.
- B. Related work:
  - 1. Documents affecting work of this Section include, but are not necessarily limited to, General Conditions, Supplementary Conditions, and Division 01 - General Requirements of these Specifications.
- C. References:
  - 1. Reserved.

1.2 SUBMITTALS

- A. Shop Drawing Submittals – None Required.
- B. Operation and Maintenance Manuals – None Required.
- C. Certificates and Guarantees – None Required.
- D. Lubricants – None Required.
- E. Spare Parts – None Required.
- F. Provide a list of names and identification of all persons to be entering the Owner's property in connection with the Work of this Contract, and submit a copy of the list to the Owner at the preconstruction conference.
  - 1. Advise the Owner of personnel changes at project meetings.

1.3 NOISE CONTROL

- A. Conduct operations to cause the least annoyance to residents in the vicinity of the Work and comply with City of Madison Ordinances.
- B. Work hours shall be between 7 AM and 7 PM, Monday thru Friday, except legal holidays and unless otherwise agreed to in writing from Owner.
- C. Equip all mechanical devices and engines with adequate silencers and mufflers.

1.4 QUALITY ASSURANCE

- A. Promptly upon award of the Contract, notify all pertinent personnel regarding requirements of this Section.
- B. Require that all personnel who will enter upon the Owner's property certify their awareness of and familiarity with the requirements of this Section.

1.5 DELIVERY, STORAGE, AND HANDLING

- A. Do not store construction equipment, tools or materials on any area of the Owner's property except where shown on the Drawings as the "Contractor's Storage Area," or where otherwise directed by the Engineer.

1.6 SITE CONDITIONS – Reserved.

1.7 MAINTENANCE – Reserved.

1.7 USE AND RESTORATION OF THE SITE

- A. Construct and maintain temporary roadways from the existing public roadway to the site and within the entire site for material and equipment transport necessary to complete the work.
- B. Before submitting Final Application for Payment, restore all areas within the work site boundaries disturbed by the Work to a fully regraded condition, provided with at least four (4) inches of hand raked topsoil and seeded as specified under Section 32 92 00.13.
- C. Clean all permanent roadways used for construction activities by using motorized street sweeper that utilizes vacuum and water to pick up debris, when directed by Engineer.

1.8 CONTRACTOR'S INGRESS AND EGRESS

- A. Truck and Equipment access:
  - 1. Provide adequate protection for curbs and sidewalks over which trucks and equipment pass to reach the work site.
- B. Contractor's vehicles:
  - 1. Do not permit vehicles to park on the Owner's driveway or property.
- C. Restoration: Clean and restore to at least the preconstruction condition all roadways, streets, sidewalks, driveways, and parking areas used during construction.

## 1.9 ACCESS TO OWNER'S FACILITIES

- A. Restricted areas and structures:
  - 1. Do not enter any designated restricted area or any existing structure, except as required to do specific work.
  - 2. Obtain Owner's permission to enter restricted areas or existing structures to do specific work.
  - 3. Remove all construction debris and clean work areas daily when working in restricted areas or existing structures.
- B. Equipment:
  - 1. Do not use Owner's equipment or tools.

## 1.10 PROTECTION OF EXISTING PROPERTY AND EQUIPMENT

- A. Property:
  - 1. Take all necessary precautions to protect existing structures, piping, trees and all other facilities from damage during construction, and comply with Section 31 23 79, paragraph 3.2 of these Specifications.
  - 2. Repair or replace all property damaged during construction.
- B. Equipment:
  - 1. Take all necessary precautions to protect all equipment from sand, dust, water and other debris which is produced during construction.
  - 2. Wherever possible, cut concrete or masonry from outside the structure to prevent production of dust in areas containing equipment.
  - 3. During dust-producing activities inside of structures, isolate work area from equipment using temporary impervious partitions or individual equipment encasement.
  - 4. Under excessive dust conditions, ventilate isolated working areas as directed by Engineer.
  - 5. Remove all temporary equipment protection facilities upon completion of construction activity requiring such protective measures.

## 1.11 DISPOSAL OF SPOIL

- A. Remove all spoil, excess excavated material, or other construction activity residual materials from the work site. Do not deposit this material on private or public property without written permission from property owner or authorized representative of the appropriate public agency.

## 1.12 SECURITY

- A. Restrict the access of all persons entering upon the Owner's property in connection with the Work to the Access Route and to the actual site of the Work.

END OF SECTION

SECTION 01 14 15

PLANT OPERATION DURING CONSTRUCTION

PART 1 - GENERAL

1.1 SUMMARY

- A. Prepare and maintain a sequence of construction which will maintain (or resume) pumping capabilities to the low pressure zone during construction.
- B. Limit the amount of facility downtime to no more than 40 total days when the facility cannot pump to the low pressure zone.
- C. Related work:
  - 1. Documents affecting the work of this Section include, but are not necessarily limited to, General Conditions, Supplementary Conditions, and Division 01 – General Requirements of these Specifications.

1.2 SUBMITTALS

- A. Comply with pertinent provisions of Section 01 33 01.
- B. Within 30 calendar days after the Contractor has received the Owner's Notice to Proceed and as a part of the construction schedule required by Section 01 32 16, submit a detailed sequence of construction showing how the new work will be completed without interruption of the existing treatment process.

1.3 OPERATION OF WATER BOOSTER FACILITIES

- A. The Owner will operate the water booster station remotely when the facility is in operation. No equipment shall be removed from service nor shall the power to any part of the booster facility be discontinued without the approval of the Engineer.
- B. When construction or installation of a specific item has been completed and the inspection, testing, and guarantee provisions of Section 01 61 01 have been complied with, and the unit may be placed into permanent operation; the Owner will assume responsibility for the normal operation and maintenance of the equipment in accordance with paragraph 14.10 of the General Conditions.

END OF SECTION

SECTION 01 26 13

REQUESTS FOR INTERPRETATION

PART 1 - GENERAL

1.1 SUMMARY: REQUESTS FOR INTERPRETATION (RFI)

- A. The Contractor may submit Requests For Interpretation (RFI) to the Engineer to expedite the Contractor's performance on the Project. RFIs will be submitted following the requirements, all as described in this Section.
- B. Related work:
  - 1. Documents affecting work of this Section include, but are not necessarily limited to, General Conditions, Supplementary Conditions, and Sections in Division 01 of these Specifications.
  - 2. Individual requirements for submittals will be described in pertinent Sections of these Specifications.
- C. Work not included:
  - 1. Incomplete submittals will not be reviewed by the Engineer.
  - 2. The Contractor may require his subcontractors to provide drawings, setting diagrams, and similar information to help coordinate the Work, but such data shall remain between the Contractor and his subcontractors and will not be reviewed by the Engineer unless specifically called for within the Contract Documents.

1.2 SUBMITTALS

- A. Make submittals of RFI's in accordance with the provisions of this Section.
- B. Prior to submitting each RFI, the Contractor shall first carefully study and compare the Contract Documents, field conditions, other Owner provided information, Contractor prepared Coordination Drawings, and prior Project correspondence and documentation to determine that the information requested is not reasonably obtainable from such sources.
- C. The Contractor shall submit each RFI sufficiently in advance of the date by which such information is required to allow the Engineer sufficient time, in the Engineer's professional judgement, to permit adequate review and response and to permit Contractor compliance with the latest construction schedule.

PART 2 - PRODUCTS

This Subsection intentionally left blank.

## PART 3 - EXECUTION

### 3.1 IDENTIFICATION OF SUBMITTALS

- A. Each RFI shall be submitted to the Engineer, in writing, on such form and with such accompanying information as the Engineer may require for such purpose. Each RFI shall identify the specific sources which were reviewed by the Contractor in its efforts to determine the information requested, and a statement to the effect that the information being requested could not be determined from such sources.
- B. Consecutively number all submittals.
  - 1. When material is submitted for any reason, transmit under a new letter of transmittal and with a new transmittal number.
  - 2. On re-submittals, cite the original submittal number for reference.
- C. Accompany each submittal with a letter of transmittal showing all information required for identification and checking.
  - 1. Use Request for Interpretation (RFI) Form, RFI 01 26 13.13-1.
- D. On at least the first page of each submittal, and elsewhere as required for positive identification, show the submittal number in which the item was included.
- E. Submittal log:
  - 1. Maintain an accurate submittal log for the duration of the Work, showing current status of all submittals at all times, the date of the request, to whom the request was made, by whom the request was made, the nature of the request, and the Engineer's resolution thereof.
  - 2. Make the submittal log available to the Engineer for the Engineer's review upon request.
  - 3. Review this log at each Project Meeting and make the resolution of RFIs a part of the minutes of such meetings.

END OF SECTION

REQUEST FOR INTERPRETATION (RFI) FORM

RFI NO. \_\_\_\_\_

Contractor requests for interpretation will be considered upon receipt of this completed RFI Form. By submission of this form the Contractor attests to the fact that having carefully reviewed the Contract Documents and coordinated the Work with the appropriate trades and reviewed field conditions, that the information requested cannot be determined from such efforts as called for in the General Conditions of the Contract.

Date: \_\_\_\_\_ Project: \_\_\_\_\_

To: \_\_\_\_\_

Description of Requested Interpretation: \_\_\_\_\_

\_\_\_\_\_

\_\_\_\_\_

Specification References: \_\_\_\_\_

Drawing References: \_\_\_\_\_

Proposed method of resolving issue. Sketches and/or Pages Attached: \_\_\_\_\_ Yes, \_\_\_\_\_ No

\_\_\_\_\_

\_\_\_\_\_

Potential impact on project cost: \_\_\_\_\_

Response Date: \_\_\_\_\_ List date by which response by Engineer is requested to maintain project schedule. (Allow sufficient time for response).

Signed: \_\_\_\_\_, Project Superintendent  
Signature signifies acceptance of responsibility for accuracy and completeness of information.

ENGINEER'S RESPONSE

Notations listed below indicate the Engineer's action on method proposed by the Contractor to resolve issues or remarks in response to RFI when no Contractor recommendation has been provided. Changes to Contract Amount and/or project time shall be processed using standard Change Order Forms. Sketched and/or Pages Attached \_\_\_\_\_ Yes \_\_\_\_\_ No

\_\_\_\_\_

\_\_\_\_\_

\_\_\_\_\_

Signed: \_\_\_\_\_ Date: \_\_\_\_\_

## SECTION 01 31 14

## PROJECT COORDINATION AND CONSTRUCTION PHASING

## PART 1 - GENERAL

## 1.1 SUMMARY

- A. This section describes the Contractor's general project coordination and construction phasing requirements under this Contract.
- B. Related work:
  - 1. Documents affecting work of this Section include, but are not necessarily limited to, General Conditions, Supplementary Conditions, and Sections in Division 01 and Division 02 of these Specifications.
- C. Coordinate construction activities with the Owner and Engineer.
- D. Follow specific procedures and project phasing requirements specified in this Section.
- E. Submit the plan of construction phasing to the Owner and Engineer for review two working days prior to the pre-construction conference.

## 1.2 SUBMITTALS

- A. Submit a detailed plan for phasing of construction in all areas and phasing of construction and restoration that will illustrate compliance with project phase completion requirements.
  - 1. Define construction activities on a week-by-week basis.
  - 2. Define subcontractor work activities.
  - 3. Allow for reasonable periods of delays caused by inclement weather.
- B. Define Contractor's plans regarding storage and staging areas.
  - 1. Include property owner representative's name and phone number.
  - 2. Outline requirements of agreement.
  - 3. Define means to be utilized to meet agreements, including security measures and restoration methods.
- C. Submit a detailed plan that indicates the methods and materials that are to be utilized for water main testing and paving.
  - 1. Submit plan at pre-construction meeting for approval by Owner and Engineer.
  - 2. Revise plan, methods, and materials to comply with comments by Owner and Engineer.



### 1.3 CONTRACTOR'S REQUIREMENTS

- A. Prepare and maintain a sequence of construction which will maintain (or resume) pumping capabilities to the low pressure zone during construction.
- B. Limit the amount of facility downtime to no more than 40 total days when the facility cannot pump to the low pressure zone.
- C. Project Completion: Complete Project as set forth in Item 1.8 A. 1., of the Supplementary Conditions, Section 00 73 00.13.
- D. Electrical Phasing: Maintain existing/temporary 120 volt power supply for duration of project construction for City 911 equipment and remove/abandon existing/temporary facilities with new 120 volt power supply from new MCC at end of project.

### PART 2 - PRODUCTS

No products are required in this Section.

### PART 3 - EXECUTION

#### 3.1 INSTALLATION

- A. Construct the proposed facilities in a timely manner and comply with these project coordination and construction phasing requirements.

END OF SECTION

SECTION 01 31 19  
PROJECT MEETINGS

PART 1 - GENERAL

1.1 DESCRIPTION

- A. Work included: To enable orderly review during progress of the Work, and to provide for systematic discussion of problems, the Engineer will conduct project meetings throughout the construction period.
- B. Related work:
  - 1. Documents affecting work of this Section include, but are not necessarily limited to, General Conditions, Supplementary Conditions, and Division 01 – General Requirements of these Specifications.
  - 2. The Contractor's relations with his subcontractors and materials suppliers, and discussions relative thereto, are the Contractor's responsibility and normally are not part of project meetings content.

1.2 SUBMITTALS

- A. Agenda items: To the maximum extent practicable, advise the Engineer at least 24 hours in advance of project meetings regarding items to be added to the agenda.
- B. Minutes:
  - 1. The Engineer will compile minutes of each project meeting, and will furnish three copies to the Contractor and required copies to the Owner.
  - 2. Recipients of copies may make and distribute such other copies as they wish.

1.3 QUALITY ASSURANCE

- A. For those persons designated by the Contractor to attend and participate in project meetings, provide required authority to commit the Contractor to solutions agreed upon in the project meetings.

PART 2 - PRODUCTS

(No products are required in this Section)

## PART 3 - EXECUTION

### 3.1 MEETING SCHEDULE

- A. Project meetings will be scheduled at the Pre-construction Meeting.
- B. Coordinate as necessary to establish mutually acceptable schedule for meetings.

### 3.2 MEETING LOCATION

- A. The Engineer will establish meeting location. To the maximum extent practicable, meetings will be held at the job site.

### 3.3 PRECONSTRUCTION MEETING

- A. Pre-construction Meeting will be scheduled to be held within 20 working days after the effective date of the Agreement.
  - 1. Provide attendance by authorized representatives of the Contractor and major subcontractors.
  - 2. The Engineer will advise other interested parties, including the Owner, and request their attendance.
- B. Minimum agenda: Data will be distributed and discussed on at least the following items:
  - 1. Organizational arrangement of Contractor's forces and personnel, and those of subcontractors, materials suppliers, and Engineer.
  - 2. Channels and procedures for communications.
  - 3. Construction schedule, including sequence of critical work.
  - 4. Contract Documents, including distribution of required copies of original Documents and revisions.
  - 5. Processing of Shop Drawings and other data submitted to the Engineer for review.
  - 6. Processing of Bulletins, field decisions, and Change Orders.
  - 7. Rules and regulations governing performance of the Work; and
  - 8. Procedures for safety and first aid, security, quality control, housekeeping, and related matters.

### 3.4 PROJECT MEETINGS

- A. Attendance:
  - 1. To the maximum extent practicable, assign the same person or persons to represent the Contractor at project meetings throughout progress of the Work.
  - 2. Subcontractors, materials suppliers, and others may be invited to attend those project meetings in which their aspect of the Work is involved.

END OF SECTION

PROJECT MEETINGS  
01 31 19-2 (140218.40)

SECTION 01 32 16

CONSTRUCTION PROGRESS SCHEDULES

PART 1 - GENERAL

1.1 SUMMARY

- A. Prepare and maintain the schedules and reports described in this Section to assure adequate planning and execution of the Work so that the Work is completed within the Contract Times, and to assist the Engineer in appraising the reasonableness of the proposed schedule and in evaluating progress of the Work.
- B. Related work:
  - 1. Documents affecting work of this Section include, but are not necessarily limited to, General Conditions, Supplementary Conditions, and Division 01 – General Requirements of these Specifications.
  - 2. Requirements for progress schedule: General Conditions.
  - 3. Construction period: Form of Agreement.

1.2 SUBMITTALS

- A. Comply with pertinent provisions of Section 01 33 01.
- B. Construction schedule: Prior to submission of the first Application for Payment, but no later than 30 calendar days after Contract Times commence, submit to the Engineer one reproducible copy and four prints of a construction schedule prepared in accordance with Part 3 of this Section.
- C. Periodic reports: Prior to submittal of Application for Payment for completed work coinciding with 50 percent and 80 percent of the Contract Price, submit to the Engineer four prints of the construction schedule updated as described in Part 3 of this Section.

1.3 QUALITY ASSURANCE

- A. Perform data preparation, analysis, charting, and updating in accordance with standards approved by the Engineer.
- B. Reliance upon the approved schedule:
  - 1. The construction schedule as approved by the Engineer will be an integral part of the Contract and will establish interim completion dates for the various activities under the Contract.
  - 2. Processing of the first Application for Payment will not be completed by the Engineer until the construction schedule has been submitted in accordance with 1.2 B. above.

CONSTRUCTION PROGRESS SCHEDULES

01 32 16-1 (140218.40)

3. Processing of the 50 percent and 80 percent progress payment applications will not be completed by the Engineer until the periodic reports have been submitted in accordance with 1.2 C. above.

## PART 2 - PRODUCTS

### 2.1 CONSTRUCTION ANALYSIS

- A. Graphically show by Critical-Path (CPM), Program Evaluation and Review Technique (PERT), Precedence Methods, bar-chart, or other means acceptable to the Engineer, the order and interdependence of all activities necessary to complete the Work, and the sequence in which each activity is to be accomplished, as planned by the Contractor and his project field superintendent in coordination with all subcontractors whose work is shown on the diagram.
- B. Include, but do not necessarily limit indicated activities to:
  1. Project mobilization.
  2. Work elements.
  3. Special material and equipment installation and testing.
  4. Final cleanup.
  5. Final inspecting and testing.
  6. All activities by the Engineer that affect progress, required dates for completion, or both, for all and each part of the work.
  7. Contractor's anticipated working dates.

## PART 3 - EXECUTION

### 3.1 CONSTRUCTION SCHEDULE

- A. As soon as practicable after receipt of Notice to Proceed, complete the construction schedule in preliminary form, meet with the Engineer, review contents of the proposed construction schedule, and make all revisions agreed upon.
- B. Submit in accordance with Paragraph 1.2 B. above.

### 3.2 PERIODIC REPORTS

- A. As required under Paragraph 1.2 C. above, update the approved construction schedule.
  1. Indicate "actual" progress in percent completion for each activity;
  2. Provide written narrative summary of revisions causing delay in the program, and an explanation of corrective actions taken or proposed.

3.3 REVISIONS

- A. Make only those revisions to approved construction schedule as are approved in advance by the Engineer.

END OF SECTION

## SECTION 01 33 01

## SUBMITTALS

## PART 1 - GENERAL

## 1.1 SUMMARY

- A. Make submittals required by the Contract Documents, and revise and resubmit as necessary to establish compliance with the specified requirements, all as described in this Section.
- B. Related work:
  - 1. Documents affecting work of this Section include, but are not necessarily limited to, General Conditions, Supplementary Conditions, and Division 01 - General Requirements of these Specifications.
  - 2. Individual requirements for submittals will be described in pertinent Sections of these Specifications.
    - a. The process for securing approval of proposed substitutions is described in Section 01 62 01, "Product Options and Substitutions."
- C. Work not included:
  - 1. Unrequired submittals will not be reviewed by the Engineer.
  - 2. The Contractor may require his subcontractors to provide drawings, setting diagrams, and similar information to help coordinate the Work, but such data shall remain between the Contractor and his subcontractors and will not be reviewed by the Engineer unless specifically called for within the Contract Documents.

## 1.2 SUBMITTALS

- A. Make submittals of Shop Drawings, Samples, Substitution Requests, progress schedules and other items in accordance with the provisions of this Section.

## 1.3 QUALITY ASSURANCE

- A. Coordination of submittals:
  - 1. Prior to each submittal, carefully review and coordinate all aspects of each item being submitted.
  - 2. Verify that each item and the submittal for it conform in all respects with the specified requirements.
  - 3. By affixing the Contractor's signature and his certification stamp to each submittal, certify that this coordination has been performed.
- B. Resubmittals and reimbursement of Engineer's costs.
  - 1. The Engineer will record all time used by the Engineer in the review of any third and subsequent submittals.

## SUBMITTALS

01 33 01-1 (140218.40)

2. The Owner will reimburse the Engineer at the Engineer's standard hourly rate for all time spent in such third and subsequent reviews and deduct such costs from payments due the Contractor.

## PART 2 - PRODUCTS

### 2.1 SHOP DRAWINGS

- A. Make Shop Drawings accurately to a scale sufficiently large to show all pertinent aspects of the item and its method of connection to the Work.
  1. Shop Drawings are not required for manholes, valve vaults, catch basins, pipe, and appurtenances needed for infrastructure systems (storm sewers, sanitary sewers, and water distribution) so long as the items are the materials and manufacturers specified in the project manual.
- B. Submit the number of copies which are required to be returned, plus five copies which will be retained by the Engineer.
  1. Collate each copy of the required number of shop drawing sets to be submitted and include one of each item for that current submittal.
- C. Collate each copy of the required number of shop drawing sets to be submitted and include one of each item for that current submittal.

### 2.2 MANUFACTURERS' LITERATURE

- A. Where contents of submitted literature from manufacturers includes data not pertinent to the submittal, clearly show which portion of the contents is being submitted for review.
- B. Submit the number of copies which are required to be returned, plus five copies which will be retained by the Engineer.

### 2.3 SAMPLES

- A. Provide Sample or Samples identical to the precise article proposed to be provided. Identify as described under "Identification of submittals" below.
- B. Number of Samples required:
  1. Unless otherwise specified, submit Samples in the quantity which is required to be returned, plus one which will be retained by the Engineer.
  2. By prearrangement in specific cases, a single Sample may be submitted for review and, when approved, be installed in the Work at a location agreed upon by the Engineer.



## 2.4 COLORS AND PATTERNS

- A. Unless the precise color and pattern is specifically called out in the Contract Documents, and whenever a choice of color or pattern is available in the specified products, submit accurate color and pattern charts to the Engineer for selection.

## 2.5 MANUFACTURERS' RECOMMENDED INSTALLATION PROCEDURES

- A. Maintain in a safe place at the site one copy of manufacturers' recommended installation procedures for all equipment and materials.
  - 1. Make these installation procedures readily available to the Engineer for reference.
- B. When the manufacturers' recommended installation procedures are submitted as part of the shop drawings required by the Contract Documents, approval of such installation procedures by the Engineer will not be required.

## PART 3 - EXECUTION

### 3.1 IDENTIFICATION OF SUBMITTALS

- A. Consecutively number all submittals.
  - 1. When material is submitted for any reason, transmit under a new letter of transmittal and with a new transmittal number.
  - 2. On resubmittals, cite the original submittal number for reference.
- B. Accompany each submittal with a letter of transmittal showing all information required for identification and checking.
  - 1. Use Contractor's Submittal Transmittal Form, Attachment 01 33 01.
- C. On at least the first page of each submittal, and elsewhere as required for positive identification, show the submittal number in which the item was included.
- D. Submittal log:
  - 1. Maintain an accurate submittal log for the duration of the Work, showing current status of all submittals at all times.
  - 2. Make the submittal log available to the Engineer for the Engineer's review upon request.

### 3.2 GROUPING OF SUBMITTALS

- A. Unless otherwise specified, make submittals in groups containing all associated items to assure that information is available for checking each item when it is received.
  - 1. Partial submittals may be rejected as not complying with the provisions of the Contract.
  - 2. The Contractor may be held liable for delays so occasioned.
  - 3. Do not submit unrelated items in group submittals.

3.3 TIMING OF SUBMITTALS

- A. Make submittals far enough in advance of scheduled dates for installation to provide time required for reviews, for securing necessary approvals, for possible revisions and resubmittals, and for placing orders and securing delivery.
- B. In scheduling, allow at least ten working days for review by the Engineer following the Engineer's receipt of the submittal.

END OF SECTION

ATTACHMENT 01 33 01

CONTRACTOR'S SUBMITTAL TRANSMITTAL FORM

TO: BAXTER & WOODMAN, INC.  
256 SOUTH PINE STREET  
BURLINGTON, WI 53105

DATE: \_\_\_\_\_

ATTN: \_\_\_\_\_

PROJECT NAME: \_\_\_\_\_

FROM: \_\_\_\_\_ SPEC NO. \_\_\_\_\_

\_\_\_\_\_ ENGR. DWG. NOS. \_\_\_\_\_

\_\_\_\_\_ TRANSMITTAL NO. \_\_\_\_\_

1. The following submittals are forwarded for your review:

<u>No. of Copies</u>	<u>Manufacturer</u>	<u>Description</u>	<u>Drawing No.</u>	<u>Date</u>
_____	_____	_____	_____	_____
_____	_____	_____	_____	_____
_____	_____	_____	_____	_____

2. Have all field measurements, field construction criteria, materials, dimensions, catalog numbers, and similar data been determined and verified? Yes \_\_\_ No \_\_\_

3. Has work indicated in this submittal been coordinated with all trades? Yes \_\_\_ No \_\_\_

4. Is work by all trades being provided as necessary to accommodate this submittal? Yes \_\_\_ No \_\_\_

5. Contractor has approved submittal and has affixed his certification stamp. Yes \_\_\_ No \_\_\_

6. Contractor's description and justification for deviations from Contract Documents.  
(Use additional sheet if necessary.)  
\_\_\_\_\_  
\_\_\_\_\_  
\_\_\_\_\_

7. Remarks: \_\_\_\_\_  
\_\_\_\_\_  
\_\_\_\_\_

Signature: \_\_\_\_\_

10/00

SECTION 01 41 26

PERMITS

PART 1 - GENERAL

1.1 SUMMARY

- A. This Section describes permit requirements for building, work in highway and railroad rights-of way, and dewatering wells.
- B. Related sections:
  - 1. Documents affecting work of this Section include, but are not necessary limited to, General Conditions and Supplementary Conditions, and Division 01 – General Requirements of these Specifications.
  - 2. Other permits requirements may also be described in other Sections of these Specifications.

1.2 BUILDING AND ELECTRICAL PERMITS

- A. Obtain all permits required, and pay all inspection fees for the respective work requiring such permits. Water Utility shall reimburse Contractor for all inspection and permit fees.

1.3 ENVIRONMENTAL PERMITS

- A. Conform with the requirements of the Wisconsin Department of Natural Resources (WDNR) and the U.S. Army Corps of Engineers permits.
- B. Obtain Air Quality Operating Permit for new generator.

END OF SECTION

## SECTION 01 42 13

## ABBREVIATIONS AND ACRONYMS

## PART 1 - GENERAL

## 1.1 SUMMARY

- A. This Section describes abbreviations referenced in the Contract Documents.
- B. Related work:
  - 1. Documents affecting work of this Section include, but are not necessarily limited to, General Conditions, Supplementary Conditions, and Division 01 – General Requirements of these Specifications.

## 1.2 ABBREVIATIONS

- A. Referenced Standards:
  - 1. Where the Contract Documents reference any published specifications or standards of any organization or association, comply with the requirements of the specification or standards which are current on the date of Advertisement for Bids. In case of a conflict between the referenced specifications or standards, the one having the more stringent requirements shall govern.
  - 2. In case of conflict between the referenced specifications or standards and the Contract Documents, the Contract Documents shall govern.
- B. Abbreviations:
  - 1. The following are definitions of abbreviations that may be used within the Project Manual:
    - AA - Aluminum Association
    - AASHTO - American Association of State Highway and Transportation Officials
    - ACI - American Concrete Institute
    - AISC - American Institute of Steel Construction
    - ANSI - American National Standard Institute
    - ASTM - American Society for Testing and Materials
    - AWG - American Wire Gauge
    - AWS - American Welding Society
    - AWWA - American Water Works Association
    - CBM - Certified Ballast Manufacturers Association
    - CRSI - Concrete Reinforcing Steel Institute
    - ICEA - Insulated Cable Engineers Association
    - IEEE - Institute of Electrical and Electronics Engineers, Inc.
    - ISA - Instrument Society of America
    - FS - Federal Specifications
    - NEC - National Electrical Code (NFPA 70)
    - NECA - National Electrical Contractors' Association

## ABBREVIATIONS AND ACRONYMS

01 42 13-1 (140218.40)

NEMA - National Electrical Manufacturer's Association  
NFPA - National Fire Protection Association or National Forest Products Association  
NSF - National Sanitation Foundation  
OSHA - U.S. Department of Labor, Occupational Safety and Health Department  
PS - United States Products Standards  
SSPC - Structural Steel Painting Council  
UL - Underwriter's Laboratories, Inc.  
WDOT - "STANDARD SPECIFICATIONS" - Wisconsin Department of Transportation, "STANDARD SPECIFICATIONS For Highway and Structure Construction"

END OF SECTION

## SECTION 01 50 00

## TEMPORARY FACILITIES AND CONTROLS

## PART 1 - GENERAL

## 1.1 SUMMARY

- A. This Section describes construction facilities and temporary controls required for the Work.
- B. Related work:
  - 1. Documents affecting work of this Section include, but are not necessarily limited to, General Conditions, Supplementary Conditions, and Division 01 - General Requirements of these Specifications.
  - 2. Except that equipment furnished by subcontractors shall comply with requirements of pertinent safety regulations, such equipment normally furnished by the individual trades in execution of their own portions of the Work are not part of this Section.
  - 3. Permanent installation and hookup of the various utility lines are described in other Sections.

## 1.2 REQUIREMENTS

- A. Provide construction facilities and temporary controls needed for the Work including, but not necessarily limited to:
  - 1. Temporary utilities such as heat, water, electricity, and telephone.
  - 2. Supplemental sanitary facilities.
  - 3. Enclosures such as fencing, tarpaulins, barricades, and canopies.
  - 4. Temporary fencing of the construction site and tree protection.
  - 5. Fire extinguishers.
  - 6. Dust and mud control.
  - 7. Security.
  - 8. Construction layout and staking.

## 1.3

## 1.3 DELIVERY, STORAGE, AND HANDLING

- A. Maintain temporary facilities and controls in proper and safe condition throughout progress of the Work.

## PART 2 - PRODUCTS

## 2.1 UTILITIES DURING CONSTRUCTION

- A. Water:
  - 1. The Owner will provide water for the initial filling for flushing and testing of new water main at no cost to the Contractor.

2. Provide necessary temporary piping and water supply and, upon completion of the work, remove such temporary facilities.
  3. The Owner will provide water for use by the Contractor for miscellaneous construction activities.
- B. Electricity:
1. Provide necessary temporary wiring and, upon completion of the Work, remove such temporary facility.
  2. The Owner will provide and pay for electricity used in construction.
  3. Maintain temporary 120 volt power supply for duration of project construction for City 911 equipment and remove/abandon at end of project.
- C. Heating:
1. Contractor may utilize existing heating and cooling systems during construction without additional cost. Provide and maintain supplemental heat necessary for proper conduct of operations needed in the Work.
- D. Telephone:
1. Provide cellular phones for key staff.

## 2.2 SANITARY FACILITIES

- A. Contractor may utilize Owner's toilet facilities at site during construction.
1. Contractor to maintain in a sanitary condition at all times and keep fully stocked with toilet paper, soap and paper towels.

## 2.3 ENCLOSURES

- A. Provide and maintain for the duration of construction all scaffolds, tarpaulins, canopies, warning signs, steps, platforms, bridges, and other temporary construction necessary for proper completion of the Work in compliance with pertinent safety and other regulations.

## 2.4 TEMPORARY FENCING AND TREE PROTECTION

- A. Provide and maintain for the duration of construction a temporary fence of design and type needed to prevent entry onto the Work by the public, including along edges of all excavations, plus tree protection fencing noted on drawings.
- B. Temporary work boundary fence.
1. Provide fence 36-inch to 48-inch in height.
    - a. Material: Polyethylene, PVC, or wood lath.
  2. Provide steel or wood posts.
    - a. Height: To support fence for total height after being driven.

## 2.5 FIRE EXTINGUISHERS

- A. Provide and maintain not less than two fire extinguishers, multi-purpose dry chemical type with UL rating of 4A-60 B:C, 10-pound capacity, Amerex Model ABC, or equal, enclosed in suitable protecting cabinets and conveniently located for proper protection.



## 2.6 CONSTRUCTION LAYOUT

- A. The Contractor shall furnish construction stakes required for layout and staking of the project.
- B. The Contractor shall provide personnel, equipment, and material to perform layout and staking and to establish supplementary benchmarks.

## PART 3 - EXECUTION

### 3.1 MAINTENANCE AND REMOVAL

- A. Maintain temporary facilities and controls as long as needed for safe and proper completion of the Work.
- B. Remove such temporary facilities and controls as rapidly as progress of the Work will permit, or as directed by the Engineer.

### 3.2 DUST AND MUD CONTROL

- A. Take necessary precautions to control dust and mud associated with the Work, subject to the approval of the Engineer.
  - 1. In dry weather, spray dusty areas daily with water in order to control dust.
  - 2. Apply calcium chloride having a minimum chemical content of 77 percent calcium chloride at an application rate of 3 pounds per square yard of surface covered at locations as directed by the Engineer.
- B. Take necessary steps to prevent the tracking of mud onto adjacent streets.
  - 1. Remove mud resulting from the construction traffic from the adjacent streets at noon and the end of each day.

### 3.3 SECURITY

- A. Take whatever measures are necessary to protect the safety of the public, workmen, and materials.
  - 1. Provide inspection of work area daily.
  - 2. Provide the security of the site, both day and night.

### 3.4 RIGHT-OF-WAY AND PROPERTY LINE CONTROL

- A. Protect all right-of-way markers, property line iron pins, and easement line iron pins during construction.
  - 1. Flag such control points prior to construction and protect the points during the course of construction.
- B. Establish tie-down control for any right-of-way markers or iron pins that may be lost or damaged during the work.

- C. Re-establish any right-of-way markers or iron pins that are lost or damaged during construction, after completion of restoration work.
- D. Provide the services of a Registered Land Surveyor for replacement of lost markers and iron pins.
  - 1. The cost for this work will be considered incidental to the Contract, and no additional compensation will be allowed.

### 3.5 CONSTRUCTION LAYOUT AND STAKING

- A. The Contractor shall place all construction layout stakes for this project. The Owner will provide adequate reference points and benchmarks. Any additional control points set by the Owner will be identified in the field to the Contractor and all field notes will be maintained by the Owner.
- B. The Contractor shall establish offset stakes, reference points, and any other horizontal or vertical controls, including supplementary benchmarks necessary to secure a correct layout of the Work.
  - 1. Stakes shall be set at sufficient intervals to assure construction is in conformance with the Drawings.
  - 2. The Contractor will not be required to set additional stakes to locate a utility line which is not included as a Pay Item in the contract or to determine property lines between private properties.
- C. The Contractor shall be responsible for having the finished work conform to the lines, grades, elevations, and dimensions shown on the Drawings.
  - 1. Any inspection or checking of the Contractor's layout by the Engineer and the acceptance of all or any part of the layout shall not relieve the Contractor of his/her responsibility to secure the proper dimensions, grades, and elevations of the several parts of the Work.
  - 2. The Contractor shall exercise care in the preservation of stakes and benchmarks and shall have them reset when any are damaged, lost, displaced, removed, or otherwise obliterated.
- D. Responsibility of the Contractor:
  - 1. The Contractor shall establish control points necessary to construct the individual project elements.
  - 2. The Contractor shall locate right-of-way and easement points. The Contractor shall set all line stakes for the construction of fences by the Contractor.
  - 3. All work shall be according to normally accepted self-checking surveying practices.
    - a. Field notes shall be kept in standard survey field notebooks and those books shall become the property of the Owner at the completion of the project.
    - b. All notes shall be neat, orderly, and in accepted form.

END OF SECTION

SECTION 01 61 01

GENERAL EQUIPMENT REQUIREMENTS

PART 1 - GENERAL

1.1 SUMMARY

- A. This Section describes the general equipment requirements applicable to all equipment and supplements the detailed equipment specifications.
- B. Related work:
  - 1. Documents affecting work of this Section include, but are not necessarily limited to, General Conditions, Supplementary Conditions, and Division 01 - General Requirements of these Specifications.
- C. References:
  - 1. Reserved.

1.2 SUBMITTALS

- A. Provide Attachment 01 61 01-1, Manufacturer's Certificate of Inspection; Attachment 01 61 01-2, Contractor's Verification of Equipment Inspection; and Attachment 01 61 01-3, Contractor's Equipment Guarantee for equipment as identified in Part 1 of the particular equipment specifications.
- B. Comply with pertinent provisions of Sections 01 33 01.

1.3 QUALITY ASSURANCE – Reserved.

1.4 DELIVERY, STORAGE, AND HANDLING – Reserved.

1.5 SITE CONDITIONS – Reserved.

1.6 MAINTENANCE – Reserved.

PART 2 - PRODUCTS

2.1 LUBRICANTS

- A. Provide lubricants of the type recommended by the equipment manufacturer for each item of equipment in sufficient quantity for start-up and initial operation of equipment.
- B. Provide lubrication fittings readily accessible from the outside of all equipment without removing covers or guards.

## 2.2 SAFETY GUARDS

- A. Cover all drive belts, chains and couplings with suitable guard fabricated of 14 gauge or heavier steel designed for easy installation and removal, unless otherwise specified.

## 2.3 ANCHORS

- A. Provide the size and number of anchor bolts, mechanical anchors and adhesive anchors determined by the equipment manufacturer unless otherwise indicated on the Drawings.
- B. Provide Type 316 stainless steel anchor bolts, threaded rods, nuts, washers, mechanical anchors, adhesive anchors, and other fastener parts for installing equipment, complying with ASTM F593 and F594.
- C. Comply with pertinent provisions of Section 05 50 00.

## PART 3 - EXECUTION

### 3.1 SHOP ASSEMBLY AND MATCHMARKING

- A. Assemble, inspect, and test equipment in the manufacturer's shop as far as is practical.
- B. Provide accurate shopmarking and identification for items to be field erected in accordance with erection details furnished with the equipment.
- C. Provide all fasteners and miscellaneous small parts to be field erected individually packaged for shipment, and identify as to location in accordance with a schedule of fasteners with the equipment.

### 3.2 INSTALLATION, INSPECTION, TESTING AND OPERATOR INSTRUCTIONS

- A. Provide the services of a qualified serviceman from the manufacturer of each piece of equipment to:
  - 1. Inspect the equipment installation including alignment, clearances, field erection where applicable, and initial lubrication where applicable.
  - 2. Ascertain that the installation is properly completed.
  - 3. Instruct the Owner's personnel in the proper operation and maintenance of the equipment in accordance with the manufacturer's recommendations.
- B. Make all changes or adjustments that may be required for a complete and proper installation and operation.
- C. After the installation has been completed in accordance with the manufacturer's instructions and in the presence of the manufacturer's serviceman, test the

ATTACHMENT 01 61 01-1

**MANUFACTURER'S CERTIFICATE OF INSPECTION**

Date of Inspection: \_\_\_\_\_

Project Name \_\_\_\_\_

Contractor: \_\_\_\_\_

Equipment Manufacturer: \_\_\_\_\_

Equipment Specification: \_\_\_\_\_

Equipment Type & Name: \_\_\_\_\_

This will certify that I, the manufacturer's representative, have completely checked and inspected the installation of this equipment and it has been properly installed in accordance with our instructions and requirements. I also certify that the equipment has been satisfactorily tested and is now ready for normal operation and use.

I have instructed the Owner's personnel in the proper operation and maintenance of the equipment which we have furnished for this project.

\_\_\_\_\_  
Manufacturer's Representative's Signature

\_\_\_\_\_  
Name and Title

**Attendees:**

\_\_\_\_\_  
Name and Title

\_\_\_\_\_  
Signature

\_\_\_\_\_  
Name and Title

\_\_\_\_\_  
Signature

\_\_\_\_\_  
Name and Title

\_\_\_\_\_  
Signature

\_\_\_\_\_  
Name and Title

\_\_\_\_\_  
Signature

\_\_\_\_\_  
Name and Title

\_\_\_\_\_  
Signature

\_\_\_\_\_  
Name and Title

\_\_\_\_\_  
Signature

ATTACHMENT 01 61 01-2

**CONTRACTOR'S VERIFICATION OF EQUIPMENT INSPECTION**

Date of inspection: \_\_\_\_\_

Project Name: \_\_\_\_\_

Contractor: \_\_\_\_\_

Equipment Manufacturer: \_\_\_\_\_

Equipment Specification: \_\_\_\_\_

Equipment Type & Name: \_\_\_\_\_

We, the Contractor for the subject project, hereby verify that the equipment manufacturer's serviceman has inspected and tested the installation of this equipment within the last 30 days and has certified that the equipment which we have furnished and installed for this project is now ready for normal operation and use by the Owner.

\_\_\_\_\_  
Contractor's Representative's Signature

\_\_\_\_\_  
Name and Title

ATTACHMENT 01 61 01-3

CONTRACTOR'S EQUIPMENT GUARANTEE

Date: \_\_\_\_\_  
Project Name: \_\_\_\_\_  
Contractor: \_\_\_\_\_  
Equipment Manufacturer: \_\_\_\_\_  
Equipment Specification: \_\_\_\_\_  
Equipment Type & Name: \_\_\_\_\_

We, the Contractor for the subject project, hereby guarantee this equipment for a period of \_\_\_ years from the date of the Owner's acceptance and use of this equipment, and shall replace or repair the equipment or any parts thereof which become defective or do not function properly during normal operation and maintenance without any additional expense to the Owner for labor or materials.

\_\_\_\_\_  
Contractor's Representative's Signature

\_\_\_\_\_  
Name and Title

ACCEPTED this \_\_\_\_\_ day of \_\_\_\_\_, 20\_\_\_\_, for Owner's use.

\_\_\_\_\_  
Owner's Representative's Signature

\_\_\_\_\_  
Name and Title

## SECTION 01 62 01

## PRODUCT OPTIONS AND SUBSTITUTIONS

## PART 1 - GENERAL

## 1.1 SUMMARY

- A. This Section describes product options available to bidders and the Contractor, plus procedures for securing approval of proposed substitutions.
- B. Related work:
  - 1. Documents affecting work of this Section include, but are not necessarily limited to, General Conditions, Supplementary Conditions, and Division 01 - General Requirements of these Specifications.
  - 2. Make submittals after the Effective Date of the Agreement in accordance with pertinent provisions of Section 01 33 01.

## 1.2 PRODUCT OPTIONS

- A. The Contract is based on standards of quality established in the Contract Documents.
  - 1. In agreeing to the terms and conditions of the Contract, the Contractor has accepted a responsibility to verify that the specified products will be available and to place orders for all required materials in such a timely manner as is needed to meet his agreed construction schedule.
  - 2. Neither the Owner nor the Engineer has agreed to the substitution of materials or methods called for in the Contract Documents, except as they may specifically otherwise state in writing.
- B. Materials and/or equipment specified by name:
  - 1. Where materials and/or equipment are specified by naming one single manufacturer and/or model number, followed by words that indicate no substitution is permitted, only the material and/or equipment named is approved for incorporation into the Work.
  - 2. Should the Contractor demonstrate to the approval of the Engineer that a specified material or method was ordered in a timely manner and will not be available in time for incorporation into this Work, the Contractor shall submit to the Engineer such data on proposed substitute materials and/or equipment as are needed to help the Engineer determine suitability of the proposed substitution.
- C. Where materials and/or equipment are specified by name and/or model number, followed by the words "or equal":
  - 1. The material and/or equipment specified by name establishes the required standard of quality.



2. Materials and/or equipment proposed by the Contractor to be used in lieu of materials and/or equipment so specified by name shall in all ways equal or exceed the qualities of the named materials and/or equipment.
3. The Contractor may propose "substitute" or "or equal" items for equipment in accordance with Paragraph 6.05 of the General Conditions.
  - a. If in the Engineer's sole discretion an item of material or equipment proposed by the Contractor does not qualify as an "or equal" item, the Engineer will notify the Contractor in writing that the item will be considered as a "substitute" item. If the Contractor wishes for the Engineer to continue the evaluation, the Contractor shall submit additional information in accordance with Paragraph 6.05.A.2 of the General Conditions.
4. The Engineer will record all time used by the Engineer to evaluate proposed substitute items. Owner will reimburse the Engineer at the Engineer's standard hourly rate for all time spent evaluating proposed substitute items and deduct such costs from payments due the Contractor. Costs associated with review of proposed "or equal" items will not be charged to the Contractor.

D. Products specified by reference to standard specifications such as ASTM and similar standards do not require submittal except for interface within the Work.

### 1.3 DELAYS

A. Delays in construction arising by virtue of the non-availability of a specified material and/or method will not be considered by the Engineer as justifying an extension of the agreed Contract Time.

END OF SECTION

## SECTION 01 66 11

## STORAGE AND PROTECTION OF MATERIAL AND EQUIPMENT

## PART 1 - GENERAL

## 1.1 SUMMARY

- A. Protect products scheduled for use in the Work by means including, but not necessarily limited to, those described in this Section.
- B. Related work:
  - 1. Documents affecting work of this Section include, but are not necessarily limited to, General Conditions, Supplementary Conditions, and Division 01 - General Requirements of these Specifications.
  - 2. Additional procedures also may be prescribed in other Sections of these Specifications.
- C. References:
  - 1. Reserved.

1.2 SUBMITTALS – Reserved.

1.3 QUALITY ASSURANCE – Reserved.

## 1.4 DELIVERY, STORAGE, AND HANDLING

- A. Comply with Section 01 14 11 for Contractor's storage area.
- B. Comply with the requirements of this Section for off-site storage.
  - 1. The Engineer reserves the right to visit and observe the off-site storage areas.
- C. Store equipment and materials in accordance with the manufacturer's instructions.
- D. Provide temporary weathertight enclosures to protect products from damage by the elements.
- E. Protect finished surfaces through which equipment and materials are handled.
- F. Provide protection for finished floor surfaces in traffic areas prior to allowing equipment or materials to be moved over such surfaces.
- G. Maintain finished surfaces clean, unmarred, and suitably protected until accepted by the Owner.
- H. Do not store plant maintenance equipment, furniture, and laboratory equipment on site until they are needed by the Owner or for progress of work.

1.5 SITE CONDITIONS – Reserved.

1.6 MAINTENANCE – Reserved.

1.7 MANUFACTURERS' RECOMMENDATIONS

- A. Except as otherwise approved by the Engineer, determine and comply with manufacturers' recommendations on product handling, storage, and protection.

1.8 PACKAGING

- A. Deliver products to the job site in their manufacturer's original container, with labels intact and legible.
  - 1. Maintain packaged materials with seals unbroken and labels intact until time of use.
  - 2. Promptly remove damaged material and unsuitable items from the job site, and promptly replace with material meeting the specified requirements, at no additional cost to the Owner.
- B. The Engineer may reject as non-complying such material and products that do not bear identification satisfactory to the Engineer as to manufacturer, grade, quality, and other pertinent information.

1.9 REPAIRS AND REPLACEMENTS

- A. In event of damage, promptly make replacements and repairs to the approval of the Engineer and at no additional cost to the Owner.
- B. Additional time required to secure replacements and to make repairs will not be considered by the Engineer to justify an extension in the Contract Time of Completion.

END OF SECTION

## SECTION 01 73 29

## CUTTING AND PATCHING

## PART 1 - GENERAL

## 1.1 SUMMARY

- A. This Section establishes general requirements pertaining to cutting (including excavating), fitting, and patching of the Work required to:
1. Make the several parts fit properly.
  2. Uncover work to provide for installing, inspecting, or both, of ill-timed work.
  3. Remove and replace work not conforming to requirements of the Contract Documents.
  4. Remove and replace defective work.
- B. Related work:
1. Documents affecting work of this Section include, but are not necessarily limited to, General Conditions, Supplementary Conditions, and Division 01 - General Requirements of these Specifications.
  2. In addition to other requirements specified, upon the Engineer's request uncover work to provide for inspection by the Engineer of covered work, and remove samples of installed materials for testing.
  3. Do not cut or alter work performed under separate contracts without the Engineer's written permission.

## 1.2 SUBMITTALS

- A. Request for Engineer's consent:
1. Prior to cutting which affects structural safety, submit written request to the Engineer for permission to proceed with cutting.
  2. Should conditions of the Work, or schedule, indicate a required change of materials or methods for cutting and patching, so notify the Engineer and secure his written permission and the required Change Order prior to proceeding.
- B. Notices to the Engineer:
1. Prior to cutting and patching performed pursuant to the Engineer's instructions, submit cost estimate to the Engineer. Secure the Engineer's approval of cost estimates and type of reimbursement before proceeding with cutting and patching.
  2. Submit written notice to the Engineer designating the time the Work will be uncovered, to provide for the Engineer's observation.

## PART 2 - PRODUCTS

### 2.1 MATERIALS

- A. For replacement of items removed, use materials complying with pertinent Sections of these Specifications.

### 2.2 PAYMENT FOR COSTS

- A. Perform cutting and patching needed to comply with the Contract Documents at no additional cost to the Owner.

## PART 3 - EXECUTION

### 3.1 SURFACE CONDITIONS

- A. Inspection:
  - 1. Inspect existing conditions, including elements subject to movement or damage during cutting, excavating, patching, and backfilling.
  - 2. After uncovering the work, inspect conditions affecting installation of new work.
- B. Discrepancies:
  - 1. If uncovered conditions are not as anticipated, immediately notify the Engineer and secure needed directions.
  - 2. Do not proceed until unsatisfactory conditions are corrected.

### 3.2 PREPARATION PRIOR TO CUTTING

- A. Provide required protection including, but not necessarily limited to, shoring, bracing, and support to maintain structural integrity of the Work.

### 3.3 PERFORMANCE

- A. Perform required excavating and backfilling as required under pertinent other Sections of these Specifications.
- B. Perform cutting and demolition by methods which will prevent damage to other portions of the Work and provide proper surfaces to receive installation of repair and new work.
- C. Perform fitting and adjusting of products to provide finished installation complying with the manufacturer's recommendations for specified equipment, products, tolerances, and finishes.

- D. Perform slight alterations needed to make adjustable parts fit to fixed parts to provide a complete installation.
- E. Refinish surfaces as necessary to match adjacent finishes.

END OF SECTION

## SECTION 01 74 23

### FINAL CLEANING

#### PART 1 - GENERAL

##### 1.1 SUMMARY

- A. Throughout the construction period, maintain the buildings and site in a standard of cleanliness as described in this Section.
- B. Related work:
  - 1. Documents affecting work of this Section include, but are not necessarily limited to, General Conditions, Supplementary Conditions, and Division 01 – General Requirements of these Specifications.
  - 2. In addition to standards described in this Section, comply with requirements for cleaning as described in other pertinent Sections of these Specifications.

##### 1.2 QUALITY ASSURANCE

- A. Conduct daily inspection, and more often if necessary, to verify that requirements for cleanliness are being met.
- B. In addition to the standards described in this Section, comply with pertinent requirements of governmental agencies having jurisdiction.

#### PART 2 - PRODUCTS

##### 2.1 CLEANING MATERIALS AND EQUIPMENT

- A. Provide required personnel, equipment, and materials needed to maintain the specified standard of cleanliness.

##### 2.2 COMPATIBILITY

- A. Use only the cleaning materials and equipment which are compatible with the surface being cleaned, as recommended by the manufacturer of the material.

#### PART 3 - EXECUTION

##### 3.1 PROGRESS CLEANING

- A. General:
  - 1. Retain stored items in an orderly arrangement allowing maximum access, not impeding traffic or drainage, and providing required protection of materials.

2. Do not allow accumulation of scrap, debris, waste material, and other items not required for construction of this Work.
3. At least twice each month, and more often if necessary, completely remove all scrap, debris, and waste material from the job site.
4. Provide adequate storage for all items awaiting removal from the job site, observing requirements for fire protection and protection of the environment.

B. Site:

1. Daily, and more often if necessary, inspect the site and pick up all scrap, debris, and waste material. Remove such items to the place designated for their storage.
2. Weekly, and more often if necessary, inspect all arrangements of materials stored on the site. Restack, tidy, or otherwise service arrangements to meet the requirements of Paragraph 3.1 A. 1. above.
3. Maintain the site in a neat and orderly condition at all times.

C. Structures:

1. Weekly, and more often if necessary, inspect the structures and pick up all scrap, debris, and waste material. Remove such items to the place designated for their storage.
2. Weekly, and more often if necessary, sweep interior spaces clean.
  - a. "Clean," for the purpose of this subparagraph, shall be interpreted as meaning free from dust and other material capable of being removed by use of reasonable effort and a hand-held broom.
3. As required preparatory to installation of succeeding materials, clean the structures or pertinent portions thereof to the degree of cleanliness recommended by the manufacturer of the succeeding material, using equipment and materials required to achieve the necessary cleanliness.
4. Following the installation of finish floor materials, clean the finish floor daily (and more often if necessary) at all times while work is being performed in the space in which finish materials are installed.
  - a. "Clean," for the purpose of this subparagraph, shall be interpreted as meaning free from foreign material which, in the opinion of the Engineer, may be injurious to the finish floor material.

### 3.2 FINAL CLEANING

- A. "Clean," for the purpose of this Article, and except as may be specifically provided otherwise, shall be interpreted as meaning the level of cleanliness generally provided by skilled cleaners using commercial quality building maintenance equipment and materials.
- B. Prior to completion of the Work, remove from the job site all tools, surplus materials, equipment, scrap, debris, and waste. Conduct final progress cleaning as described in Paragraph 3.1 above.



- C. Site:
  - 1. Unless otherwise specifically directed by the Engineer, broom clean paved areas on the site and public paved areas adjacent to the site.
  - 2. Completely remove resultant debris.
  
- D. Structures:
  - 1. Exterior:
    - a. Visually inspect exterior surfaces and remove all traces of soil, waste materials, smudges, and other foreign matter.
    - b. Remove all traces of splashed materials from adjacent surfaces.
    - c. If necessary to achieve a uniform degree of cleanliness, hose down the exterior of the structure.
    - d. In the event of stubborn stains not removable with water, the Engineer may require light sandblasting or other cleaning at no additional cost to the Owner.
  - 2. Interior:
    - a. Visually inspect interior surfaces and remove all traces of soil, waste materials, smudges, and other foreign matter.
    - b. Remove all traces of splashed material from adjacent surfaces.
    - c. Remove paint droppings, spots, stains, and dirt from finished surfaces.
  - 3. Glass: Clean inside and outside.
  - 4. Polished surfaces: To surfaces requiring routine application of buffed polish, apply the polish recommended by the manufacturer of the material being polished.
  
- E. MCC/Electrical Cabinets:
  - 1. Vacuum out all Motor Control and Electrical Cabinets.
  
- F. Schedule final cleaning as approved by the Engineer to enable the Owner to accept a completely clean Work.

### 3.3 CLEANING DURING OWNER'S OCCUPANCY

- A. Should the Owner occupy the Work or any portion thereof prior to its completion by the Contractor and acceptance by the Owner, responsibilities for interim and final cleaning shall be as determined by the Engineer in accordance with the General Conditions of the Contract.

END OF SECTION

SECTION 01 77 01  
CONTRACT CLOSEOUT

PART 1 - GENERAL

1.1 SUMMARY

- A. This Section describes an orderly and efficient transfer of the completed Work to the Owner.
- B. Related work:
  - 1. Documents affecting work of this Section include, but are not necessarily limited to, General Conditions, Supplementary Conditions, and Division 01 – General Requirements of these Specifications.
  - 2. Activities relative to Substantial Completion and Contract closeout are described in the General Conditions.

1.2 QUALITY ASSURANCE

- A. Prior to requesting that the Engineer issue a certificate of Substantial Completion in accordance with Paragraph 14.04 or 14.05 of the General Conditions, use adequate means to assure that the Work is completed in accordance with the specified requirements and is ready for a joint inspection by Owner, Contractor, and Engineer.

1.3 PROCEDURES

- A. Substantial Completion:
  - 1. Prepare the list required by Paragraph 14.04.A of the General Conditions and submit it along with a written request that Engineer issue a certificate of Substantial Completion.
  - 2. Within a reasonable time after receipt of the list, Owner, Contractor, and Engineer will jointly inspect the Work to determine status of completion.
  - 3. Should the Engineer determine that the Work is not substantially complete:
    - a. The Engineer will so notify the Contractor, in writing, giving the reasons therefore.
    - b. Remedy the deficiencies and notify the Engineer when ready for reinspection.
    - c. Owner, Contractor, and Engineer will reinspect the Work.
  - 4. When the Engineer concurs that the Work is substantially complete:
    - a. The Engineer will prepare a tentative "Certificate of Substantial Completion," accompanied by the Contractor's list of items to be completed or corrected, as verified by the Engineer.
    - b. The Engineer will submit the tentative Certificate to the Contractor for acceptance.

- c. After Contractor signs and returns the tentative Certificate to Engineer, Engineer will submit the tentative Certificate to Owner accompanied by a tentative list of items to be completed or corrected before final payment.
- d. Owner will have seven days after receipt of the tentative Certificate during which to make objection to Engineer as to any provisions of the Certificate on attached list.
  - (1) If Owner objects, Engineer will consider Owner's objections. If, after considering Owner's objections, Engineer concludes that the Work is not substantially complete, Engineer will, within fourteen days after submission of the tentative Certificate to Owner, notify Contractor in writing, stating reasons therefor. If, after considering Owner's objections, Engineer considers the Work substantially complete, Engineer will within said fourteen days execute and deliver to Owner and Contractor, a definitive Certificate of Substantial Completion (with a revised tentative list of items to be completed or corrected) reflecting such changes from the tentative Certificate as Engineer believes justified after consideration of any objections of Owner.
  - (2) If Owner has no objections, Engineer will within fourteen days after submission of the tentative Certificate to Owner and Contractor issue a definitive Certificate of Substantial Completion.
- e. At the time of delivery of the tentative Certificate of Substantial Completion, Engineer will deliver to Owner and Contractor a written recommendation as to division of responsibilities pending final payment between Owner and Contractor with respect to security, operation, safety, maintenance, heat, utilities, insurance, warranties, and guarantees. Unless Owner or Contractor advise the Engineer in writing of any objections within seven days after delivery of the tentative Certificate of Substantial Completion, the Engineer's aforesaid recommendation will be binding on Owner and Contractor until final payment.

B. Final Completion:

- 1. Prepare and submit the notice required by the first sentence of Paragraph 14.06.A of the General Conditions.
- 2. Verify that the Work is complete including, but not necessarily limited to, the items mentioned in Paragraph 14.07.A of the General Conditions.
- 3. Certify that:
  - a. Contract Documents have been reviewed.
  - b. Work has been inspected for compliance with the Contract Documents.
  - c. Work has been completed in accordance with the Contract Documents.

- d. Equipment and systems have been tested as required, and are operational.
  - e. Work is completed and ready for final inspection.
  4. Owner, Contractor, and Engineer will make a joint inspection to verify status of completion.
  5. Should the Engineer determine that the Work is incomplete or defective:
    - a. The Engineer will so notify the Contractor, in writing, listing the incomplete or defective work.
    - b. The Contractor will remedy the deficiencies promptly, and notify the Engineer when ready for reinspection.
  6. When the Engineer determines that the Work is acceptable under the Contract Documents, he will request the Contractor to make closeout submittals.
- C. Closeout submittals include, but are not necessarily limited to:
1. Project Record Documents described in Section 01 78 39.
  2. Manufacturer's Certificate of Inspection, Contractor's Verification of Equipment Inspection, and Contractor's Equipment Guarantee for each item of equipment as required in Section 01 61 01.
  3. Warranties and bonds.
  4. Spare parts and materials extra stock.
  5. Evidence of compliance with requirements of governmental agencies having jurisdiction including, but not necessarily limited to:
    - a. Certificates of Inspection.
    - b. Certificates of Occupancy.
  6. Certificates of Insurance for products and completed operations;
  7. Evidence of payment and release of liens; and
  8. Affidavit of Compliance with Prevailing Wage Rate Determination and Affirmative Action requirements.
  9. List of subcontractors, service organizations, and principal vendors, including names, addresses, and telephone numbers where they can be reached for emergency service at all times including nights, weekends, and holidays.
- D. Final adjustment of accounts:
1. Submit a final statement of accounting to the Engineer, showing all adjustments to the Contract Price.
  2. If so required, the Engineer will prepare a final Change Order showing adjustments to the Contract Price which have not been made by previous Change Orders.

END OF SECTION

## SECTION 01 78 26

### OPERATION AND MAINTENANCE MANUAL

#### PART 1 - GENERAL

##### 1.1 SUMMARY

- A. To aid the continued instruction of operating and maintenance personnel, and to provide a positive source of information regarding products incorporated into the Work, furnish and deliver the manuals described in pertinent Sections of these Specifications.
- B. Related work:
  - 1. Documents affecting work of this Section include, but are not necessarily limited to, General Conditions, Supplementary Conditions, and Division 01 – General Requirements of these Specifications.

##### 1.2 SUBMITTALS

- A. Comply with pertinent provisions of Section 01 33 01.
- B. Submit three copies of the required manuals for each item of equipment to the Engineer no later than 30 days following the Engineer's approval of shop drawings for said item of equipment, plus an electronic version in searchable .pdf format.

##### 1.3 QUALITY ASSURANCE

- A. Use only personnel who are thoroughly trained and experienced in operation and maintenance of the described items, completely familiar with the requirements of this Section, and skilled in technical writing to the extent needed for communicating the essential data.

#### PART 2 - PRODUCTS

##### 2.1 OPERATION AND MAINTENANCE MANUALS

- A. Where operation and maintenance manuals are required to be submitted under other Sections of these Specifications, prepare in accordance with the provisions of this Section.
- B. Format:
  - 1. Size: 8-1/2" x 11".
  - 2. Paper: White bond, at least 20 lb. weight.
  - 3. Text: Neatly written or printed.

4. Drawings: 11" in height preferable; bind in with text; foldout acceptable; larger drawings acceptable but fold to fit within the manual and provide a drawing pocket inside rear cover or bind in with text.
5. Flysheets: Separate each portion of the manual with neatly prepared flysheets briefly describing contents of the ensuing portion; flysheets may be in color.
6. Binding: Use heavy-duty plastic or fiberboard covers with binding mechanism concealed inside the manual; 3-ring binders will be acceptable.
7. Measurements: Provide all measurements in U.S. standard units such as feet-and-inches, lbs, and cfm; where items may be expected to be measured within ten years in accordance with metric formulas, provide additional measurements in the "International System of Units" (SI).

C. Provide front and back covers for each manual, using durable material, and clearly identified on or through the cover with at least the following information:

OPERATING AND MAINTENANCE MANUALS

( \_\_\_\_\_ )  
( Name and address of Work \_\_\_\_\_ )  
( \_\_\_\_\_ )  
( name of Contractor \_\_\_\_\_ )  
( \_\_\_\_\_ )  
( general subject of this Manual \_\_\_\_\_ )  
( \_\_\_\_\_ )  
( Engineer, and approval date \_\_\_\_\_ )

- D. Contents: Include at least the following:
1. Neatly typewritten index near the front of the manual, giving immediate information as to location within the manual of all emergency information regarding the installation.
  2. Complete instructions regarding operation and maintenance of all equipment involved including lubrication, disassembly, and reassembly.
  3. Complete nomenclature of all parts of the equipment.
  4. Complete nomenclature and part number of all replaceable parts, name and address of nearest vendor, and all other data pertinent to procurement procedures.
  5. Manufacturers' bulletins, cuts, and descriptive data, where pertinent, clearly indicating the precise items included in this installation and deleting, or otherwise clearly indicating, all manufacturers' data with which this installation is not concerned.
  6. Such other data as required in pertinent other Sections of these Specifications.

PART 3 - EXECUTION

3.1 TIMING AND PAYMENT

- A. Make submittals far enough in advance of scheduled dates for equipment installation to provide at least ten (10) working days for review by the Engineer following the Engineer's receipt of the submittal.
- B. Payment for the fabrication, delivery, or installation of any equipment will be withheld until the Engineer has received the required operation and maintenance manual(s).

END OF SECTION

## SECTION 01 78 39

## PROJECT RECORD DOCUMENTS

## PART 1 - GENERAL

## 1.1 SUMMARY

- A. Throughout progress of the Work, maintain an accurate record of changes in the Contract Documents, as described in Paragraph 3.1 below and, upon completion of the Work, submit the recorded changes as described in Paragraph 3.2 below.
- B. Related work:
  - 1. Documents affecting work of this Section include, but are not necessarily limited to, General Conditions, Supplementary Conditions, and Division 01 – General Requirements of these Specifications.
  - 2. Other requirements affecting Project Record Documents may appear in pertinent other Sections of these Specifications.

## 1.2 SUBMITTALS

- A. Comply with pertinent provisions of Section 01 33 01.
- B. The Engineer's approval of the current status of Project Record Documents may be a prerequisite to the Engineer's approval of requests for progress payment and request for final payment under the Contract.
- C. Prior to submitting each request for progress payment, secure the Engineer's approval of the current status of the Project Record Documents.
- D. Prior to submitting request for final payment, submit the final Project Record Documents to the Engineer and secure his approval.

## 1.3 QUALITY ASSURANCE

- A. Delegate the responsibility for maintenance of Record Documents to one person on the Contractor's staff as approved by the Engineer.
- B. Accuracy of records:
  - 1. Thoroughly coordinate changes within the Record Documents, making adequate and proper entries on each page of Specifications and each sheet of Drawings and other Documents where such entry is required to show the change properly.
  - 2. Accuracy of records shall be such that future search for items shown in the Contract Documents may rely reasonably on information obtained from the approved Project Record Documents.



- C. Make entries within 24 hours after receipt of information that the change has occurred.
- D. Do not conceal any work until the required information is recorded.

#### 1.4 DELIVERY, STORAGE, AND HANDLING

- A. Maintain the job set of Record Documents completely protected from deterioration and from loss and damage until completion of the Work and transfer of all recorded data to the final Project Record Documents.
- B. In the event of loss of recorded data, use means necessary to again secure the data to the Engineer's approval.
  - 1. Such means shall include, if necessary in the opinion of the Engineer, removal and replacement of concealing materials.
  - 2. In such case, provide replacements to the standards originally required by the Contract Documents.

### PART 2 - PRODUCTS

#### 2.1 RECORD DOCUMENTS

- A. Job set: Promptly following receipt of the Owner's Notice to Proceed, secure from the Engineer at no charge to the Contractor one complete set of all Documents comprising the Contract.

### PART 3 - EXECUTION

#### 3.1 MAINTENANCE OF JOB SET

- A. Immediately upon receipt of the job set described in Paragraph 2.1.A above, identify each of the Documents with the title, "RECORD DOCUMENTS - JOB SET."
- B. Preservation:
  - 1. Considering the Contract completion time, the probable number of occasions upon which the job set must be taken out for new entries and for examination, and the conditions under which these activities will be performed, devise a suitable method for protecting the job set.
  - 2. Do not use the job set for any purpose except entry of new data and for review by the Engineer.
  - 3. Maintain the job set at the site of Work where designated by the Engineer.

- C. Making entries on Drawings:
  - 1. Using an erasable colored pencil (not ink or indelible pencil), clearly describe the change by graphic line and note as required.
  - 2. Date all entries.
  - 3. Call attention to the entry by a "cloud" drawn around the area or areas affected.
  - 4. In the event of overlapping changes, use different colors for the overlapping changes.
- D. Make entries in the pertinent other Documents as approved by the Engineer.
- E. Conversion of schematic layouts:
  - 1. In some cases on the Drawings, arrangements of conduits, circuits, piping, ducts, and similar items, is shown schematically and is not intended to portray precise physical layout.
    - a. Final physical arrangement is determined by the Contractor, subject to the Engineer's approval.
    - b. However, design of future modifications of the facility may require accurate information as to the final physical layout of items which are shown only schematically on the Drawings.
  - 2. Show on the job set of Record Drawings, by dimension accurate to within one inch, the centerline of each run of items such as are described in Paragraph 3.1 E. 1. above.

### 3.2 REVIEW AND SUBMITTAL

- A. Submit the completed set of Project Record Documents to the Engineer as described in Paragraph 1.2 D. above.
- B. Participate in review meetings as required.
- C. Make required changes and promptly deliver the final Project Record Documents to the Engineer.

### 3.3 CHANGES SUBSEQUENT TO ACCEPTANCE

- A. The Contractor has no responsibility for recording changes in the Work subsequent to Final Completion, except for changes resulting from work performed under Warranty.

END OF SECTION

SECTION 01 91 58  
FACILITY START-UP

PART 1 - GENERAL

1.1 SUMMARY

- A. This Section describes the Contractor's general equipment requirements for facility start-up.
- B. Related work:
  - 1. Documents affecting work of this Section include, but are not necessarily limited to, General Conditions, Supplementary Conditions, and Division 01 and Division 02 of these Specifications.

1.2 SUBMITTALS

- A. Submit a detailed plan and schedule for start-up of the facility at least thirty (30) days prior to the scheduled start-up of the facility.

PART 2 - PRODUCTS

No products are required in this Section.

PART 3 - EXECUTION

3.1 CONTRACTOR'S REQUIREMENTS

- A. In addition to the services required to comply with Section 01 61 01, Articles 3.2 and 3.3, provide the services of a qualified and experienced factory employed field service engineer from each equipment manufacturer:
  - 1. Ascertain that equipment has been installed in accordance with the manufacturer's recommended procedures.
  - 2. Ascertain that equipment is operational and ready for start-up.
  - 3. Make necessary repairs, corrections, and/or modifications prior to the scheduled start-up.
- B. Coordinate efforts of various equipment field service engineers with construction activities including painting and facility disinfection.
  - 1. Complete painting of equipment containing process water prior to disinfection.
  - 2. Successfully complete facility disinfection prior to start-up in accordance with appropriate provisions of AWWA C-653.
- C. Perform the above services at least two weeks prior to the scheduled start-up.

(6/05)

- D. Perform the facility start-up procedures in the presence of the Owner and Engineer.
- E. Operate the facility without problems for a period of fourteen (14) consecutive days prior to Owner's acceptance of the facility.

END OF SECTION

FACILITY STARTUP  
01 91 58-2 (140218.40)

SECTION 02 41 53

DEMOLITION, REMOVAL AND ABANDONMENT

PART 1 - GENERAL

1.1 SUMMARY

- A. This Section describes demolition and removal of structures and parts of structures, removal of above grade and underground improvements, and abandonment of underground structures and pipelines as shown on the Drawings and specified in this Section.
- B. Related work:
  - 1. Documents affecting work of this Section include, but are not necessarily limited to, General Conditions, Supplementary Conditions, and Division 01 - General Requirements of these Specifications.
- C. References:
  - 1. Reserved.

1.2 SUBMITTALS

- A. Shop Drawing Submittals – None Required.
- B. Operation and Maintenance Manuals – None Required.
- C. Certificates and Guarantees – None Required.
- D. Lubricants – None Required.
- E. Spare Parts – None Required.

1.3 QUALITY ASSURANCE

- A. Use adequate numbers of skilled workmen who are thoroughly trained and experienced in the necessary crafts and who are familiar with the specified requirements and the methods needed for proper performance of the work of this Section.

1.4 DELIVERY, STORAGE, AND HANDLING

- A. Comply with pertinent provisions of Section 01 66 11.

1.5 SITE CONDITIONS – Reserved.

1.6 MAINTENANCE – Reserved.

1.7 DEFINITIONS

- A. Demolish – Raze and dispose of above grade structures; including, but not limited to walls, ground floor slabs and floors. Raze and dispose of all equipment, piping and plumbing, electrical and communications conduit, wires and cables, furnishings in above grade and below grade structures.
- B. Remove – Excavate structure foundations, underground pipes, etc. in their entirety.
- C. Dispose – Transport or haul materials and equipment of any and all types to off-site location(s).
- D. Abandon – Remove structure foundations, tanks, and underground pipes, etc within the following limits
  - 1. 5 feet horizontally from any proposed structure or pipe, and
  - 2. 3 feet vertically below the proposed finished grade or the outside edges of any proposed structure or pipe.
- E. Salvage – Carefully remove intact for future use by Owner. Includes all Utility disconnections, capping, safe handling and transporting to Owner's facility at 119 E. Olin Avenue.
- F. This work includes breaking up of below grade foundation slabs and sealing of underground pipes with mechanical plugs and/or concrete plugs.

PART 2 - PRODUCTS

2.1 MATERIALS

- A. Provide materials, not specifically described but required for proper completion of the work of this Section, as selected by the Contractor subject to the approval of the Engineer.
- B. Grout for filling of abandoned pipes and structures:
  - 1. Cellular grout:
    - a. Low density cellular concrete capable of being mixed on site and pumped into place through a 2-inch hose.
    - b. Foaming agent complying with ASTM C869.
    - c. Portland Cement: ASTM C150, Type I or Type II.
    - d. Contents: Cement, fly ash, water and foaming agent.
    - e. Minimum net density: 70 pcf.
    - f. Acceptable manufacturer:
      - (1) Mearl Geofam Liquid Concentrate.
      - (2) Or equal.

## PART 3 - EXECUTION

### 3.1 SURFACE CONDITIONS

- A. Examine the areas and conditions under which work of this Section will be performed. Correct conditions detrimental to timely and proper completion of the Work. Do not proceed until unsatisfactory conditions are corrected.

### 3.2 PROTECTION

- A. Protect existing utilities indicated or made known.
- B. Protect trees and shrubs, where indicated to remain, by plank wrappers securely wired in place or by providing a fence around the tree or shrub of sufficient distance away and of sufficient height so trees and shrubs will not be damaged in any way as part of this Work.
  - 1. Do not permit any equipment to operate within 5 feet of any trees or shrubs that are to remain or in a manner as to harm overhanging branches.
- C. Protection of persons and property:
  - 1. Barricade open depressions and holes occurring as part of this Work, and post warning lights on property adjacent to or with public access.
  - 2. Operate warning lights during hours from dusk to dawn each day and as otherwise required.
  - 3. Protect structures, utilities, sidewalks, pavements, and other facilities from damage caused by settlement, lateral movement, undermining, washout, and other hazards created by operations under this Section.
- D. Use means necessary to prevent dust becoming a nuisance to the public, to neighbors, and to other work being performed on or near the site.
- E. Maintain access to the site at all times.

### 3.3 DEMOLITION

- A. General:
  - 1. By careful study of the Contract Documents and visiting the site, determine the location and extent of demolition to be performed.
  - 2. In all activities, comply with pertinent regulations of governmental agencies having jurisdiction.
- B. Demolition of existing structures:
  - 1. Demolish and remove existing structures, piping and equipment or parts thereof in a manner such as not to damage corresponding items which are to remain.
  - 2. In those areas in which structures or piping to be demolished and removed now occupy space to be used for proposed structures, remove the existing

structure or piping in total unless other instructions are included on the Drawings.

C. Existing equipment:

1. Existing mechanical or electrical equipment, miscellaneous metals, pipe, fittings, valves, cabinets, and other materials of whatever nature are, and shall be considered to be "Salvage" and shall remain the property of the Owner, unless specifically noted as to be demolished.

3.4 ABANDONMENT OF STRUCTURES AND PIPING

A. Structures:

1. In those areas where structures do not now occupy space to be used for proposed structures, remove structures to a depth of not less than 3 feet below finished grade.
2. Break up or core hole slab portions of structures which may remain in part as specified above and fill voids with granular materials.
3. Plug piping which may remain in part as specified above with concrete for a distance of not less than 12 inches from the end of the pipe to remain in place.

B. Below Grade Water System:

1. Abandon below grade water mains indicated on the Drawings as "to be abandoned" only after all requirements for testing and disinfection have been satisfied and all existing services have been connected to new water mains.
2. Provide concrete plugs in all water main pipes to be abandoned at the limits of the trench excavations, or at other locations if so indicated by the Drawings.
3. Provide ductile iron plugs, caps, or other necessary fittings, and thrust blocking, on ends of portions of existing water mains that are to remain in service.
4. Close existing water valves only with the permission of the Engineer.
5. Remove below grade valves and valve boxes and fill excavations with compacted granular material.
8. Dispose of buried valves, valve boxes, fire hydrants, frames and grates, and all other buried water system pipe and appurtenances off-site.
9. Where abandonment of existing water mains or appurtenances require work outside of the work zone, restore area of work as indicated on the Drawings or Sections 32 10 00.13 of the Specifications.
10. Removal of existing water mains being replaced by new water mains in the same location is considered incidental to the installation of the new water main and no additional compensation will be allowed.



### 3.5 DISPOSAL

- A. General:
  - 1. Dispose of all debris from demolition work.
  - 2. Dispose away from the site in a legal manner.
  - 3. Do not store or accumulate debris at the job site.
- B. Do not burn debris at the site.
- C. Prepare documentation identifying the hauler, generator, place of origin of debris or soil, the weight or volume of debris or soil, and the location, owner, and operator of the facility where debris or soil was transferred, disposed, recycled or treated. Maintain documentation for three years.

### 3.6 UTILITIES

- A. Coordinate with utility companies and agencies as required.
- B. Where utility cutting, capping, or plugging is required, pay utility company to do the work, or perform such work in accordance with requirements of the utility company or governmental agency having jurisdiction.

END OF SECTION

## SECTION 03 30 00

## CAST-IN-PLACE CONCRETE

## PART 1 - GENERAL

## 1.1 SUMMARY

- A. Provide cast-in-place concrete, including formwork and reinforcement, as shown on the Drawings, as specified herein, and as needed for a complete and proper installation.
- B. Related work:
  - 1. Documents affecting work of this Section include, but are not necessarily limited to, General Conditions, Supplementary Conditions, and Division 01 - General Requirements of these Specifications.
- C. References:
  - 1. Reserved.

## 1.2 SUBMITTALS

- A. Shop Drawing Submittals:
  - 1. Prior to placing concrete on the project, submit the following to the Engineer for approval:
    - a. Testing laboratory reports for each proposed concrete mix, design proportions and sieve analysis, and soundness tests for fine and coarse aggregates.
    - b. Test results for strength, slump, and entrained air content in accordance with the latest requirements of ASTM C39 and ASTM C192 on trial mix or field-testing records completed within previous 24 months. Perform strength tests on two test cylinders after 7 days curing and on two cylinders after 28 days curing.
    - c. Evidence of compliance with ASTM specifications for materials proposed to be used in the concrete mix.
    - d. Detailed reinforcing bar fabrication drawings prepared in accordance with ACI 315 including location of bar splices proposed by the Contractor in addition to those shown on the Drawings.
    - e. Casting plan indicating the location of construction joints which are proposed by the Contractor in addition to those shown on the Drawings.
  - 2. Submit, within 10 days of testing, duplicate copies of each laboratory report for concrete tests on samples taken at the jobsite, including the following information in each test report:
    - a. Project name.
    - b. Description of concrete work.
    - c. Quantity of concrete placed.
    - d. Dates of samples and testing.

- e. Slump.
  - f. Total air content.
  - g. Compressive strength.
  - h. Air temperature at time of sampling.
3. Submit manufacturer's data to prove compliance with the specifications for the following products:
- a. Non-shrink grout.
  - b. Waterstops.
  - c. Rubber waterstops.
  - d. Epoxy adhesive.

- B. Operation and Maintenance Manuals – None Required.
- C. Certificates and Guarantees – None Required.
- D. Lubricants – None Required.
- E. Spare Parts – None Required.
- F. Comply with pertinent provisions of Section 01 33 01.

### 1.3 QUALITY ASSURANCE

- A. Use adequate numbers of skilled workmen who are thoroughly trained and experienced in the necessary crafts and who are completely familiar with the specified requirements and the methods needed for proper performance of the work of this Section.
- B. Comply with "Specifications for Structural Concrete for Buildings," ACI 301, except as may be modified herein.
- C. Provide access for, and cooperate with, the inspector and testing laboratory.

### 1.4 DELIVERY, STORAGE, AND HANDLING

- A. Comply with pertinent provisions of Section 01 66 11.
- B. Provide proper storage for reinforcing steel at the project site, including protective covering and blocking to keep steel off the ground.

### 1.5 SITE CONDITIONS – Reserved.

### 1.6 MAINTENANCE – Reserved.

## PART 2 - PRODUCTS

### 2.1 FORMS

- A. Use smooth, clean plywood or metal lined panels in good condition for forming exposed concrete surfaces including interior and exterior walls, beams, columns, and slabs. Coat the forms with a non-staining, non-reactive mineral oil.
- B. Use form liners for exposed ceilings.
- C. Provide 3/4-inch chamfers on exposed corners.
- D. When reusing lumber for formwork, remove nails, thoroughly clean, and fill and finish holes to produce smooth concrete surfaces free of defects.
- E. Provide temporary openings at the base of column and wall forms and elsewhere as required to facilitate cleaning and final inspection prior to concrete placement.
- F. Form Ties: Factory-fabricated steel snap-off or coil tie assemblies designed to resist the lateral pressure of fresh concrete on forms and to prevent spalling of concrete on removal.
  - 1. Furnish tie assemblies that will leave no metal or other material except concrete within 1½ inches of the formed surface when forms, inserts and tie ends are removed.
  - 2. Furnish tie assemblies that provide cone-shaped depressions in the forms at the surface, at least 1-inch in diameter and 1½ inches deep, to allow filling and patching.
  - 3. Provide ties with integral steel or neoprene waterstop at midpoint for liquid containment structures, sludge storage structures, spill containment areas and below grade structures with accessible spaces.
  - 4. Do not use common wire for form ties.

### 2.2 REINFORCEMENT

- A. Comply with the following:
  - 1. Bars: Deformed billet steel conforming to ASTM A615, grade 60, unless otherwise shown on the Drawings.
  - 2. Welded wire reinforcement: Sheets of longitudinal and transverse cold drawn smooth steel wires electrically welded together at intersections, conforming to ASTM A185.
  - 3. Tie wire: 16 gauge annealed steel wire.
- B. Fabricate reinforcement in accordance with the latest provisions of ACI 318 "Building Code Requirements for Structural Concrete".
- C. Shop fabricate bars by cold bending to the dimensions and shapes shown on the detail shop drawings unless otherwise shown on the Drawings or approved by the Engineer.

- D. Use bars that are free from paint, oil, dirt, scale, or excessive rust which will destroy or reduce the bond when embedded in concrete.

### 2.3 CONCRETE

- A. Comply with the following:
  - 1. Portland cement: ASTM C150, Type I or II.
  - 2. Aggregate, general:
    - a. ASTM C33, uniformly graded and clean;
    - b. 35 to 50 percent ratio of fine aggregate to total aggregate by weight of surface dry materials.
  - 3. Aggregate, coarse: Pass a 1.500-inch sieve.
  - 4. Aggregate, fine: Pass a 0.375-inch sieve.
  - 5. Water: Fresh, clean, and free of oils, acids, alkalies, organic matter and deleterious substances.
- B. Provide concrete with the following properties:
  - 1. Minimum 28-day compressive strength: 4,000 psi.
  - 2. Maximum water-cement ratio: 0.45 by weight.
  - 3. Minimum cement content: 520 pounds per cubic yard.
  - 4. Minimum slump: 1-inch.
  - 5. Maximum slump:
    - a. 3 inches for footings.
    - b. 4 inches for slabs, walls, beams, girders, and columns.
- C. Use air-entrained concrete except where a smooth steel trowel finish is required. Provide a total air content of 4 to 6 percent by volume.

### 2.4 GROUT

- A. Grout for non-structural fillets: One part Portland Cement, three parts fine aggregate, and sufficient water to obtain a consistency for easy placing and finishing.
- B. Non-shrink grout:
  - 1. Furnish pre-mixed, non-metallic, non-staining, non-corrosive, non-gas liberating, cement-based grout specifically recommended by the manufacturer for interior and exterior applications and complying with U.S. Corps of Engineers' Specification CRD C-621 and ASTM C1107.
  - 2. Acceptable products:
    - a. Multipurpose Grout, Dayton Superior Corporation.
    - b. Or equal.

### 2.5 CONCRETE ADMIXTURES

- A. Air-entraining admixtures: Conform to the latest requirements of ASTM C260.
- B. Water reducing admixtures:
  - 1. Conform to the latest requirements of ASTM C494.
  - 2. Type A (normal setting type) for all concrete.

3. Type D (retarding setting type) or Type E (accelerating setting type) when approved by the Engineer.

C. Fly ash admixtures (when approved by the Engineer):

1. Maximum sulfur trioxide content: 5 percent.
2. Maximum loss of ignition: 5 percent.

D. Do not add calcium chloride, salts, or chemical antifreeze compounds to concrete.

## 2.6 EPOXY ADHESIVE

A. Provide a cartridge type, two-component, high solids epoxy adhesive system dispensed and mixed through a static mixing nozzle supplied by the manufacturer.

B. Furnish material suitable for anchorage of reinforcing bars and threaded rods in cracked and uncracked concrete to resist long-term sustained loading, tested and qualified in accordance with the International Code Council Acceptance Criteria for Post-installed Adhesive Anchors in Concrete Elements (AC308).

C. Acceptable products:

1. Hilti Inc., HIT-RE 500-SD.
2. Simpson Strong-Tie, SET-XP.
3. No substitution permitted.

## 2.7 OTHER MATERIALS

A. Cement mortar: One part Portland Cement, 2½ parts fine aggregate, and sufficient water to obtain a maximum slump of 6 inches.

B. Bonding grout: One part cement, one part fine aggregate, and sufficient water to obtain the consistency of thick cream.

C. Patching mortar: One part cement, 2½ parts fine aggregate, and sufficient water to obtain a maximum slump of 1-inch.

D. Rubber Waterstops: Chloroprene rubber and modified chloroprene (hydrophilic) rubber waterstop with delay coating to inhibit initial expansion due to moisture present in fresh concrete.

1. Chloroprene rubber performance requirements:

- a. Tensile strength (ASTM D412): 1300 psi minimum.
- b. Ultimate elongation (ASTM D412): 400 percent minimum.
- c. Tear resistance (ASTM D624): 100 lb./inch minimum.
- d. Hardness, shore A (ASTM D2240): 50 ± 5.

2. Modified chloroprene (hydrophilic) rubber performance requirements:

- a. Tensile strength (ASTM D412): 350 psi minimum.
- b. Ultimate elongation (ASTM D412): 600 percent minimum.
- c. Tear resistance (ASTM D624): 50 lb./inch minimum.
- d. Hardness, shore A (ASTM D2240): 52 ± 5.

3. Accessory materials: Adhesives, epoxy gel and sealant supplied by the waterstop manufacturer for securing and splicing of rubber waterstop.
4. Acceptable product:
  - a. Greenstreak, Hydrotite CJ-0725-3k and Accessories.
  - b. No substitution permitted.
- E. Joint sealants: Comply with Section 07 92 00.
- F. Expansion joint filler material: Asphalt type conforming to the latest requirements of ASTM D994.
- G. Curing and sealing compound: Clear, non-yellowing, water-based, acrylic liquid membrane-forming curing and sealing compound complying with ASTM C1315, Type 1, Class A.
  1. Maximum VOC content: 50g/L.
  2. Acceptable products:
    - a. W. R. Meadows, VOCOMP-30.
    - b. Or equal.
- H. Dissipating curing compound: Water based, hydrocarbon resin liquid membrane-forming dissipating curing compound complying with ASTM C309, Type 1, Class B.
  1. Maximum VOC content: 100 g/L.
  2. Acceptable products:
    - a. W. R. Meadows, 1100-CLEAR.
    - b. Or equal.
- I. Provide other materials, not specifically described but required for a complete and proper installation, as selected by the Contractor subject to the approval of the Engineer.

## PART 3 - EXECUTION

### 3.1 SURFACE CONDITIONS

- A. Examine the areas and conditions under which work of this Section will be performed. Correct conditions detrimental to timely and proper completion of the Work. Do not proceed until unsatisfactory conditions are corrected.

### 3.2 FORMS

- A. Design, erect, support, brace, and maintain formwork to safely support vertical and lateral loads until such loads can be supported safely by the concrete structure.
- B. Assemble forms with tight flush joints securely clamped to prevent leakage of mortar. Brace forms to safely support concrete without deformation under load.

- C. Construct forms within the tolerance limits of permissible variations from lines, grades, and dimensions shown on the Drawings, in accordance with ACI 347 "Recommended Practice for Concrete Formwork".
- D. Construct forms to the exact sizes, shapes, lines, and dimensions shown, and as required to obtain accurate alignment, location, grades, and level and plumb work in the finished structure.
- E. Support forms for slabs supported on steel or precast concrete beams from the same beams or framing so that deflection of structural supports will occur with the placing of the concrete.
- F. Notify the Engineer when formwork is complete so that a proper check may be made at least 24 hours prior to concrete placement.
- G. Carefully remove forms, ensuring complete protection of the structure.
- H. Remove forms for vertical sides of walls, beams, girders, columns, and other similar structural members 24 hours minimum after placement of concrete, provided the concrete has hardened sufficiently and will not be damaged.
- I. Do not remove forms and bracing for slabs, beams, girders, and similar structural members until the concrete structural members have attained sufficient strength to safely support their own weight and any construction or storage load.

### 3.3 REINFORCING

- A. Comply with the following, as well as the specified standards, for details and methods of reinforcing placement and supports.
  - 1. Clean reinforcement and remove loose dust and mill scale, earth, and other materials that reduce bond or destroy bond with concrete.
  - 2. Accurately place and secure reinforcing steel within the tolerances required by ACI 318 using tie bars, chairs, bolsters, wire, clips or other devices approved by the Engineer.
  - 3. Provide plastic protected bar supports for slab reinforcing.
  - 4. Place bar supports for grade beams and slabs on bearing plates or blocks to prevent displacement into the earth subgrade.
  - 5. Place reinforcement to obtain the following clear concrete coverage for protection, within tolerance limits specified in ACI 318 "Building Code Requirements for Structural Concrete":
    - a. Concrete cast against and permanently exposed to earth: 3 inches.
    - b. Concrete exposed to earth, liquid, weather, or bearing on work mat or slabs supporting earth.
      - (1) Slabs and joists: 2 inches.
      - (2) Beams and columns:
        - i. Stirrups, spirals, and ties: 2 inches.
        - ii. Primary reinforcement: 2½ inches.
      - (3) Walls: 2 inches.



- (4) Footings and base slabs:
  - i. Formed surfaces: 2 inches.
  - ii. Top of footings and base slabs: 2 inches.
- (5) Shells, folded plate members: 1½ inches
- c. Other conditions:
  - (1) Slabs and joists:
    - i. No. 11 bars and smaller: ¾-inch.
    - ii. No. 14 and No. 18 bars: 1½ inches.
  - (2) Beams and columns:
    - i. Stirrups, spirals, and ties: 1½ inches.
    - ii. Primary reinforcement: 2 inches.
  - (3) Walls:
    - i. No. 11 bars and smaller: ¾-inch.
    - ii. No. 14 and No. 18 bars: 1½ inches.
- 6. Provide the following minimum clear distances between parallel reinforcing bars, between adjacent contact splices, and between a contact splice and an adjacent bar:
  - a. Columns: 1½ inches, 1.5 times the bar diameter, or 1.5 times the maximum size of the coarse aggregate, whichever is larger.
  - b. Other elements: 1-inch, one bar diameter, or 1.33 times the maximum size of coarse aggregate, whichever is larger.
- 7. Reinforcing bar splices:
  - a. Use contact lap splices securely tied to adjacent bars and installed with lap lengths shown on the Drawings.
  - b. Stagger splices in adjacent reinforcing bars unless otherwise shown on the drawings or specified:
    - (1) Beams and slabs: Splice bottom bars over supports and top bars at midspan.
    - (2) Nonprestressed circular and oblong circular tanks:
      - i. Stagger splices in horizontal and ring reinforcement bars (center of lap below to center of lap above) by not less than one lap length or 3 feet, minimum.
      - ii. Stagger splices such that vertical arrays do not coincide in more frequently than every third bar.
  - c. Welded only where shown on the Drawings, conforming to the requirements of AWS D12.1.
- 8. Install welded wire reinforcement in lengths as long as practicable, lapping adjoining pieces two full mesh panels minimum.

### 3.4 WATERSTOPS

- A. Install waterstop embedded in concrete and spanning construction, control and expansion joints to create a continuous diaphragm to prevent fluid migration for liquid containment structures, sludge storage structures, spill containment areas and below grade structures with accessible spaces.
- B. Rubber waterstop:
  - 1. Install and splice rubber waterstop in accordance with manufacturer's instructions.

2. Provide a minimum of 2 inches of concrete cover over rubber waterstop.
3. Install centered in joint unless otherwise shown on the Drawings.
4. Prepare concrete surfaces and use manufacturer's recommended accessory materials to install and splice waterstops.

### 3.5 EMBEDDED ITEMS

- A. Provide for the proper placement and support of fittings, inserts, fixtures, and sleeves to be built into the concrete work under other sections of the Specifications.
- B. Shop paint non-ferrous metal surfaces of embedded items as described in Section 05 50 00 of these Specifications.

### 3.6 MIXING CONCRETE

- A. Project site batched-mixed concrete:
  1. Mix in accordance with ACI 318, Chapter 5.8.1 and 5.8.3.
- B. Ready-mixed concrete:
  1. Pre-mix and transport to project site in accordance with ASTM C94.
  2. Record time of departure from the mixing plant and batch weights of cement and water on the delivery tickets.
  3. Water may be added to the ready-mixed concrete once after delivery, only if the maximum water cement ratio and slump will not be exceeded.
  4. Reject concrete not in place within 60 minutes after introducing water to the mix when transported in agitator trucks or within 30 minutes after introducing water to the mix when transported in nonagitator trucks.

### 3.7 PLACING CONCRETE

- A. Preparation:
  1. Remove hardened concrete and foreign material from conveying equipment.
  2. Remove foreign matter and excess water accumulated in forms.
  3. Rigidly close temporary openings left in formwork.
  4. Thoroughly sprinkle earth subgrades for structural slabs without vapor barrier protection to eliminate moisture absorption.
  5. Before depositing new concrete on or against concrete which has hardened:
    - a. Thoroughly clean hardened concrete and saturate with water.
    - b. Thoroughly cover hardened concrete surface with a 1/8-inch thick coating of neat cement mortar and place new concrete before the mortar has attained its initial set.
  6. Use only clean tools.
- B. Conveying:
  1. Convey concrete from the mixer to place of final deposit as rapidly as practical by methods which will prevent separation or loss of ingredients and assure the required quality of concrete.
  2. Deposit concrete as nearly as practicable to its final location to avoid separation due to rehandling and flowing.

3. Do not allow free fall of concrete to exceed 5 feet.
  4. Do not use concrete which becomes non-plastic and unworkable, or does not meet required quality control limits, or has been contaminated by foreign materials.
  5. Remove rejected concrete from job site.
- C. Placing concrete in forms:
1. Deposit concrete continuously or in layers so that no concrete will be placed on concrete which has hardened sufficiently to cause cold joints in the work.
  2. If necessary, add construction joints, approved by the Engineer.
  3. Remove temporary spreaders, screeds, etc. as they become unnecessary.
- D. Placing concrete slabs:
1. Deposit and consolidate concrete slabs in a continuous operation, within limits of construction joints, until placing of a panel or section is completed.
  2. Bring slab surfaces to correct level with a straightedge, and then strike off.
  3. Use bullfloats or darbies to smooth the surface, leaving it free of bumps and hollows.
  4. Do not sprinkle water on plastic surface. Do not disturb slab surface prior to start of finishing operations.
  5. Place beams, girders, brackets, column capitals, haunches, and drop panels integrally with slabs.
- E. Do not begin placement of concrete in supported structural members until concrete previously placed in columns and walls is no longer plastic.

### 3.8 CONSOLIDATION

- A. General:
1. Consolidate each layer of concrete immediately after placing, by use of mechanical vibrators supplemented by hand spading, rodding, or tamping so that the concrete is thoroughly worked around reinforcement, embedded items, and into corners of the forms, eliminating all air or stone pockets which may cause honeycomb, pitting, or planes of weakness.
  2. Use mechanical vibrators with a minimum frequency of 7,000 revolutions per minute.
  3. Insert vibrator at points approximately 18 inches apart for approximately 5 to 15 seconds at each point, sufficient to consolidate concrete, but not to cause segregation.
  4. Do not overvibrate or use vibrators to transport concrete inside forms.
  5. Provide a spare vibrator and auxiliary power source at the site during placement operations.

### 3.9 JOINTS

- A. Construction joints:
1. Do not relocate construction joints shown on the Drawings or add construction joints, unless approved by the Engineer. Where additional

construction joints are approved by the Engineer, provide waterstops consistent with design.

2. Form construction joints perpendicular to main reinforcement and near quarter points of slabs, beams, and girders.
3. Limit spacing of vertical construction joints to 40 feet in any one direction.
4. Locate horizontal wall and column construction joints at the top of footings and grade slabs and the underside of slabs, beams, and girders.
5. Continue reinforcing steel across construction joints as shown on the Drawings or as required by the Engineer.
6. Form keyways in construction joints a minimum of 1½ inches deep and 3½ inches wide unless otherwise shown on the Drawings.
7. Provide the following minimum bearing lengths on concrete walls and columns unless otherwise shown on the Drawings:
  - a. 2 inches for slabs.
  - b. 6 inches for beams and girders.

B. Expansion joints:

1. Form expansion joints ½-inch wide with chamfered edges.
2. Fill expansion joints full depth with expansion joint material.
3. Do not permit reinforcement or other embedded metal items that are being bonded with concrete (except dowels in floors bonded on only one side of the joints) to extend continuously through any expansion joint.

C. Contraction joints:

1. Sawcut joints: Cut ¼-inch wide joints to a minimum depth of ¼ the thickness of the slab, but not less than 1-inch. Perform saw cutting within 12 hours of placement when cutting action will not tear, abrade, or otherwise damage surface and before concrete develops random contraction cracks.
2. Formed joints: Insert preformed plastic or hard board joint strips into the concrete to form ¼-inch wide joints to a minimum depth of 1-inch.
3. Fully caulk joints with sealant.

### 3.10 CONCRETE FINISHING

- A. Finish concrete work to smooth, clean surfaces of uniform color with no roughness or imperfections.
- B. Remove roughness, projections, honeycomb, and other defects in formed concrete surfaces to sound concrete.
- C. Patch depressions and tie holes immediately after form removal.
  1. Thoroughly wet areas to be patched to prevent absorption of water from patching mortar.
  2. Thoroughly brush bonding grout on areas to be patched.
  3. Consolidate patching mortar into place and strike off to leave a patch slightly higher than surrounding concrete surface to allow for initial shrinkage.
  4. Leave patch area undisturbed for at least one hour before final finishing.

5. Prepared proprietary compounds for bonding grout and patching mortar may be used in lieu of or in addition to the above patching procedure, if approved by the Engineer.
- D. Unless otherwise shown on the Drawings, provide the following finishes at the indicated locations:
1. Scratch finish:
    - a. Monolithic slab surfaces that are to receive concrete floor topping or mortar setting bed.
  2. Float finish:
    - a. Monolithic slab surfaces that are to receive trowel finish and other slab finishes specified herein.
    - b. Slab surfaces which are to receive a separate concrete topping, terrazzo, quarry tile, waterproofing membranes, and roofing.
  3. Trowel finish:
    - a. Monolithic slab surfaces that are to be exposed to view, unless otherwise shown.
    - b. Slab surfaces that are to be covered with resilient flooring, carpeting, paint, or asphalt.
    - c. Slab surfaces of channels, tanks, reservoirs, basins, and chambers.
  4. Non-slip broom finish:
    - a. Walks, stairs, drives, ramps, and similar pedestrian and vehicular areas.
    - b. Apply by dragging coarse bristle broom or burlap belt across concrete with uniform parallel overlapping strokes.
  5. As-formed finish:
    - a. Surfaces adjacent to earth and more than 12 inches below finished grade level.
    - b. Other surfaces not exposed to view.
  6. Smooth rubbed grout finish:
    - a. Exposed concrete surfaces including walls, beams, columns, and other vertical and inclined surfaces.
    - b. Undersides of walkways and slabs.
    - c. Tops and vertical or inclined surfaces of walls, inside tanks, reservoirs, basins, and chambers.
    - d. Surfaces adjacent to earth, stone, sand, or other special media to a depth of 12 inches below the required material grade line or low water level.
    - e. Apply finish to freshly hardened concrete as soon as possible after removal of forms.
    - f. Apply grout slurry, consisting of one part cement to 1½ parts fine aggregate mixed with water, uniformly over a predampened surface with clean burlap pads or with sponge-rubber or cork floats.
    - g. Rub grout surface with carborundum stone or similar abrasive to produce a uniform color and texture.
    - h. Remove excess grout with a dry burlap pad or a brush.

### 3.11 CONCRETE CURING

- A. Protect fresh concrete and grout surfaces from premature drying and excessively hot or cold temperatures.
- B. Cure fresh concrete and grout surfaces in a moist condition at a relatively constant temperature for at least 7 days after placement of Type I Portland Cement concrete, or longer if necessary for hydration and proper hardening of the concrete.
- C. Perform curing by one of the following methods:
  - 1. Ponding or continuous water spraying on concrete surface.
  - 2. Covering concrete surfaces with continuously wetted burlap, cotton, or other absorptive mats or fabric.
  - 3. Covering concrete surfaces with impervious waterproof paper or polyethylene film having 4-inch tape-sealed laps at common edges and taped-sealed and weighted perimeter.
  - 4. Applying curing compound on concrete surfaces to which additional concrete will not be bonded in strict accordance with manufacturer's instructions:
    - a. For interior exposed horizontal floors, stairway landings and tread surfaces which will not receive floor covering or other coatings, apply two uniform coats of curing and sealing compound:
      - (1) Apply first coat when the surface water disappears and the concrete surface will not be marred by walking workers.
      - (2) Apply second coat at right angles to the first coat after the first coat has thoroughly dried.
    - b. For all other horizontal surfaces, apply uniform coat of dissipating curing compound when the surface water disappears and the concrete surface will not be marred by walking workers.
    - c. For vertical surfaces, apply uniform coat of dissipating curing compound promptly after removal of forms.
- D. Maintain temperature of fresh concrete between 50 degrees and 70 degrees F for the required curing period.
- E. Provide and erect necessary facilities for heating, covering, insulating, or housing the concrete work for cold weather protection.

### 3.12 CONCRETE TESTING

- A. Provide equipment and services required for sampling and testing concrete.
- B. Include the cost of testing in the total amount of the contract price for concrete work.
- C. Sample concrete in accordance with ASTM C172.
- D. Slump testing:
  - 1. Perform in accordance with ASTM C143.
  - 2. Perform one test minimum for each 50 cubic yards of concrete placed in one operation to check and maintain the required consistency of concrete.

3. Perform whenever required by the Engineer.
- E. Air content testing:
1. Perform concurrently with the taking of the concrete compression test cylinder specimens.
  2. Perform in accordance with one of the following methods:
    - a. ASTM C231 pressure method.
    - b. ASTM C173 volumetric method.
    - c. ASTM C138 gravimetric method.
- F. Compression testing:
1. Make and cure compression test cylinder specimens in accordance with ASTM C31.
  2. Take one set of four (4) 6-inch x 12-inch cylinders or six (6) 4-inch x 8-inch cylinders for every concrete pour for structural slabs, walls, beams, girders, footings, and columns, and additional sets for each 100 cubic yards of concrete placed in one operation.
  3. Take test cylinder specimens as directed by the Engineer to obtain representative samples of the concrete materials.
  4. Cure the specimens on the job site under the same field conditions as the concrete work they represent for a minimum of 72 hours after sampling.
  5. Test half of each set of concrete test cylinder specimens for compressive strength at 7 days and at 28 days in accordance with ASTM C39 (testing to be performed by an independent testing laboratory approved by the Engineer).
  6. In any case where test results of concrete cylinder specimens fail to meet minimum compressive strength requirements, make additional tests in accordance with ASTM C42 or perform load tests in accordance with ACI 318, as required by the Engineer.
  7. If these alternate strength tests show that concrete work does not meet minimum strength requirements, remove unsatisfactory concrete and reconstruct the work.
- 3.13 CUTTING AND PATCHING OF EXISTING CONCRETE
- A. Provide neat and smooth finished exposed surfaces.
  - B. Provide 1-inch deep (minimum) saw cuts.
  - C. Cut off exposed reinforcing bars a minimum of 1½-inch back of finished surface and fill remaining cavity with patching mortar.
  - D. Provide straight and square lines at finished openings and ¾-inch chamfers at exposed corners.
  - E. Core drill openings for new pipes and conduits and patch with non-shrink grout.
  - F. Grind exposed finished surfaces flush to meet and match existing surfaces.

### 3.14 ANCHORING WITH EPOXY ADHESIVE

- A. Drill holes, prepare surface, dispense and mix epoxy adhesive through a static mixing nozzle supplied by the manufacturer, and set reinforcement bars and threaded rod anchors in accordance with the manufacturer's recommendations where shown on the Drawings.
1. Identify position of reinforcing steel and other embedded items prior to drilling holes. Do not cut or damage reinforcing steel, prestressed steel tendons, piping, conduits or other embedded items. Notify the Engineer if reinforcing steel or other embedded items encountered during drilling.
  2. Use rotary impact hammer drills with carbide-tipped bits of diameters as specified by the epoxy adhesive manufacturer.
  3. Drill holes perpendicular to surface of concrete after has achieved full design strength.
  4. Clean holes to remove loose material and drilling dust prior to installation of epoxy adhesive.
  5. Follow manufacturer's recommendations to ensure proper mixing of epoxy adhesive components.
  6. Inject epoxy adhesive into holes proceeding from the bottom of the hole and progressing toward the surface in such a manner as to avoid introduction of air pockets in the epoxy adhesive.
  7. Inject sufficient epoxy adhesive in the hole to ensure that the annular gap is filled to the surface. Remove excess epoxy adhesive from the surface. Shim anchors with suitable device to center the anchor in the hole. Do not disturb or load anchors before manufacturer specified cure time has elapsed.
  8. Observe manufacturer's recommendations with respect to installation temperatures.

### 3.15 REMEDIAL WORK

- A. Repair or replace deficient work as directed by the Engineer and at no additional cost to the Owner.

END OF SECTION



SECTION 03 48 00

PRECAST CONCRETE SPECIALTIES

PART 1 - GENERAL

1.1 SUMMARY

- A. Provide precast concrete specialties as shown on the Drawings, as specified herein, and as needed for a complete and proper installation.
- B. Related work:
  - 1. Documents affecting work of this Section include, but are not necessarily limited to, General Conditions, Supplementary Conditions, and Division 01 - General Requirements of these Specifications.
  - 2. Section 03 30 00, Cast-in-Place Concrete.
- C. References:
  - 1. Reserved.

1.2 SUBMITTALS

- A. Shop Drawing Submittals – None Required.
- B. Operation and Maintenance Manuals – None Required.
- C. Certificates and Guarantees – None Required.
- D. Lubricants – None Required.
- E. Spare Parts – None Required.

1.3 QUALITY ASSURANCE – Reserved.

1.4 DELIVERY, STORAGE, AND HANDLING

- A. Comply with pertinent provisions of Section 01 66 11.
- B. Storage:
  - 1. Store units at jobsite in a manner to prevent cracking, distortion, warping, staining, and other physical damage.

1.5 SITE CONDITIONS – Reserved.

1.6 MAINTENANCE – Reserved.

## PART 2 - PRODUCTS

### 2.1 PRECAST UNITS

- A. Pilaster Cap: Smooth, uniform in size, color and texture, and sufficiently reinforced to allow transport without damage. Provide with sloped surface to shed rainwater.

### 2.2 CONCRETE

- A. Design strength:
  - 1. Unless otherwise indicated on the Drawings, or approved by the Engineer, design the mix and proportion the concrete to attain a minimum compressive strength of 3,000 psi when cured and tested at 28 days in accordance with ASTM C39.

## PART 3 - EXECUTION

### 3.1 INSTALLATION

- A. Install the work of this Section as shown on the Drawings.

END OF SECTION

SECTION 04 20 00

UNIT MASONRY

PART 1 - GENERAL

1.1 SUMMARY

- A. Provide unit masonry as shown on the Drawings, as specified herein, and as needed for a complete and proper installation.
- B. Related work:
  - 1. Documents affecting work of this Section include, but are not necessarily limited to, General Conditions, Supplementary Conditions, and Division 01 - General Requirements of these Specifications.
- C. Face Brick Cash allowance: Provide within the proposed Contract Price a material cost of \$600 per thousand for material costs including delivery and unloading of face brick to site. Contractor to provide costs for any overhead and profit plus installation and handling of face brick elsewhere in bid.
- D. References:
  - 1. Reserved.

1.2 SUBMITTALS

- A. Shop Drawing Submittals:
  - 1. Laboratory testing completed within the last 12 months on brick and concrete masonry units sampled from lots ready for delivery to prove compliance with the specified requirements.
  - 2. Product data: Submit design mixes for mortar and grout including evidence of compliance with ASTM specifications for materials proposed.
  - 3. Detailed reinforcing bar fabrication drawings indicating location of the bar splices proposed in addition to those shown on Drawings.
- B. Operation and Maintenance Manuals – None Required.
- C. Certificates and Guarantees – None Required.
- D. Lubricants – None Required.
- E. Spare Parts – None Required.
- F. Comply with pertinent provisions of Section 01 33 01.

- G. Samples:
  - 1. Selection of samples will be for size, color and general appearance only. Compliance with all other requirements is the responsibility of the Contractor.
  - 2. Submit samples of brick units showing size, quality, texture and color for selection by the Owner.
  - 3. Submit samples of mortar showing color for selection by the Owner.

### 1.3 QUALITY ASSURANCE

- A. Use adequate numbers of skilled workmen who are thoroughly trained and experienced in the necessary crafts and who are completely familiar with the specified requirements and the methods needed for proper performance of the work of this Section.

### 1.4 DELIVERY, STORAGE, AND HANDLING

- A. Comply with pertinent provisions of Section 01 66 11.
- B. Store masonry units off ground to prevent contamination by mud, dust or materials likely to cause staining or other defects.
- C. Store masonry units above ground on level platforms which allow air circulation under the stacked units.
- D. Cover and protect concrete masonry units against wetting prior to use.

### 1.5 SITE CONDITIONS – Reserved.

### 1.6 MAINTENANCE – Reserved.

## PART 2 - PRODUCTS

### 2.1 BRICK

- A. Face brick:
  - 1. Provide modular size units complying with ASTM C216, grade SW, type FBS.
  - 2. Match existing face brick to existing brick fence wall.
  - 3. Unit size, texture and color are subject to approval by the Owner.

### 2.2 CONCRETE MASONRY UNITS

- A. Provide standard modular size concrete masonry units with uniform texture and color.
- B. Furnish concrete masonry units produced in advance to allow a minimum 28 day cure prior to use.

- C. Where concrete blocks are called for or indicated on the Drawings:
  - 1. Provide hollow concrete masonry units complying with ASTM C90 for load bearing and non-load bearing walls.
- D. Provide accessory shapes as indicated or otherwise required.

### 2.3 MORTAR MATERIALS

- A. General:
  - 1. Water: Provide potable water free from injurious amounts of acids, alkalis, oils, and organic matter.
  - 2. Color pigment: Provide pure ground mineral oxides, non-fading and alkali proof admixture complying with C979, approved by the Engineer.
  - 3. Admixtures: Do not use antifreeze compounds, salts, or admixture.
- B. Brick, concrete and masonry units:
  - 1. Portland Cement: Comply with ASTM C150, Type I. "Masonry" cement will not be acceptable.
  - 2. Hydrated lime: Comply with ASTM C207, Type S.
  - 3. Mortar aggregate: Comply with ASTM C144.

### 2.4 GROUT MATERIALS

- A. Grout:
  - 1. Portland Cement: Comply with ASTM C150, Type I. "Masonry" cement will not be acceptable.
  - 2. Hydrated lime: Comply with ASTM C207, type S.
  - 3. Grout aggregate: Comply with ASTM C404.
  - 4. Water: Provide potable water free from injurious amounts of acids, alkalis, oils, and organic matter.
  - 5. Admixtures: Do not use antifreeze compounds, salts, or admixture.

### 2.5 JOINT REINFORCEMENT

- A. Comply with the following:
  - 1. Deformed reinforcement wire: ASTM A496.
  - 2. Wire ties: ASTM A82.
  - 3. Hot dip galvanized coating applied after fabrication:
    - a. Comply with ASTM A153, Class B.
    - b. Minimum coating of 1.5 ounces per square foot.
- B. Use prefabricated ladder type horizontal joint reinforcing conforming to ASTM A951 manufactured in 10-foot long sections.
- C. Use prefabricated sections of joint reinforcing at corners and wall intersections to maintain continuity at corners.
- D. Cavity Wall and Composite Wall Reinforcing:
  - 1. Provide three parallel longitudinal deformed 9 gauge side rods.

2. Space longitudinal side rods to allow for 1-inch mortar cover.
  3. Provide 9 gauge cross rods welded at 16-inch intervals to side rods.
- E. Single Wythe Wall Reinforcing:
1. Provide two parallel longitudinal deformed 9 gauge side rods.
  2. Space longitudinal side rods to allow for 1-inch mortar cover.
  3. Provide 9 gauge cross rods welded at 16-inch intervals to side rods.

## 2.6 REINFORCEMENT

- A. Comply with the following:
1. Bars: Deformed billet steel conforming to ASTM A615, grade 60, unless otherwise shown on the Drawings.
  2. Tie wire: 16 gauge annealed steel wire.
  3. Rebar positioners: 9 gauge galvanized steel wire.
- B. Fabricate reinforcement in accordance with the latest provisions of ACI 318 "Building Code Requirements for Structural Concrete".
- C. Shop fabricate bars by cold bending to the dimensions and shapes shown on the detail shop drawings unless otherwise shown on the Drawings or approved by the Engineer.
- D. Use bars that are free from paint, oil, dirt, scale, or excessive rust which will destroy or reduce the bond when embedded in grout.

## 2.7 MASONRY ANCHORS

- A. Comply with the following:
1. Wire: Comply with ASTM A82.
  2. Sheet Steel: Comply with ASTM A568.
  3. Hot dip galvanized coating applied after fabrication: Comply with ASTM A153, Class B.
- B. Dovetail Anchors:
1. Provide 26 gauge steel dovetail anchor slots with polystyrene filler.
  2. Provide 9 gauge triangular wire anchors.

## 2.8 JOINT STABILIZING ANCHORS

- A. Provide heavy duty stainless steel joint stabilizing anchors with 1/4-inch diameter fastener holes equal to D/A 2200 Heavy Duty manufactured Dur-O-Wal, Inc.

## 2.9 CONTROL JOINT GASKET

- A. Provide factory-extruded solid rubber joint gaskets equal to Dur-O-Wal Rapid Control Joint Rubber Compound manufactured by Dur-O-Wal, Inc.

2.10 JOINT SEALANTS

- A. Comply with Section 07 92 00.

2.11 FLASHING

- A. Provide PVC base flashing 30 mils thick.

2.12 BEARING STRIPS

- A. Provide neoprene strips 1-inch wide and ¼-inch thick with a durometer hardness of 50.

PART 3 - EXECUTION

3.1 PREPARATION

- A. Layout modular masonry coursing to avoid using pieces less than 4 inches long.
- B. Examine the areas and conditions under which work of this Section will be performed. Correct conditions detrimental to timely and proper completion of the Work. Do not proceed until unsatisfactory conditions are corrected.
- C. Foundations:
  - 1. Do not commence installation until foundations are clean, rough, and level.
  - 2. Remove laitance, loose aggregate and any foreign material that prevents mortar from bonding to the foundation.
  - 3. Verify that the foundation elevation is such that the bed joint thickness will be between 1/4-inch and 1/2-inch.

3.2 ENVIRONMENT AND PROTECTION

- A. Cold weather requirements: Comply with cold weather construction requirements contained in ACI 530.1/ASCE 6/TMS 602.
  - 1. Protect masonry work from freezing during cold weather:
  - 2. Provide enclosures and heating devices to keep the air temperature around the work above 40 degrees F.
  - 3. Maintain air temperature above 40 degrees F during construction and for 48 hours after work has been completed.
- B. Hot weather requirements: Comply with hot weather construction requirements contained in ACI 530.1/ASCE 6/TMS 602.
- C. Cover unfinished masonry work for protection when work is stopped at the end of the day.

### 3.3 MORTAR MIXING

- A. General:
1. Measure ingredients accurately.
  2. Prepare mortar in accordance with C270 to produce a workable dense mixture.
  3. Preheat water and aggregate when necessary to produce a mortar temperature above 40 degrees F.
  4. Do not retemper mortar after initial set occurs.
  5. Discard and do not use mortar which is unused after 1½ hours following initial mixing.
  6. Add color pigment to mortar mix in accordance with manufacturer's recommendations.
- B. For brick and concrete masonry units, provide type N mortar consisting of:
1. One part Portland Cement; to
  2. One part hydrated lime; to
  3. Six parts mortar aggregate measured damp and loose.

### 3.4 GROUT MIXING

- A. General:
1. Measure ingredients accurately.
  2. Prepare mortar in accordance with C476 to produce a workable dense mix having slump of 8 to 11 inches.
  3. Discard and do not use mortar which is unused after 1½ hours following initial mixing.
- B. Provide fine grout consisting of:
1. One part Portland Cement; to
  2. One-tenth part hydrated lime; to
  3. Three parts grout aggregate.

### 3.5 INSTALLATION

- A. Laying:
1. General:
    - a. Unless otherwise indicated on the Drawings, make the masonry work plumb, level, and true to line, with square angles and corners.
    - b. Construct masonry such that all exposed surfaces are free from chips, pinholes and other imperfections.
    - c. Use masonry that is clean and free from dust and other foreign matter.
    - d. Spalled, cracked or broken pieces of masonry can be used as backup where concealed.
    - e. Lay in running bond unless otherwise shown on the Drawings.
    - f. Tooling of masonry is not acceptable.
    - g. Completely fill mortar joints to provide a watertight surface.



- h. Use a carborundum saw to make straight, smooth, sharp edges when cutting masonry.
  - i. Lay facing masonry and back up masonry simultaneously.
  - j. Where mortar has moved or shifted, remove and lay again in fresh mortar.
  - k. Build anchors, grounds, inserts, frames, thimbles, brackets, nailers, flashing, lintels, bearing plates and other items into the masonry as work progresses.
  - l. Construct masonry such that the fit around windows, doors, panels, cut-out cabinets and openings is close and neat.
  - m. Set sills and ends of lintels in full mortar beds.
  - n. Use standard units to provide square internal corners and lintel edges.
  - o. Immediately remove mortar and grout from areas where they are not scheduled to be placed.
- B. Brick:
- 1. Thoroughly wet brick prior to laying when so directed by the Engineer to control excessive absorption of moisture from the mortar.
  - 2. Provide 3/8-inch mortar joints.
- C. Concrete masonry units:
- 1. Use only dry concrete masonry units.
  - 2. Provide 3/8-inch mortar joints.
  - 3. Provide fully grouted units for the top course of walls except where noted on the Drawings.
  - 4. Use bullnose units for external corners and jambs.
  - 5. Where acoustical concrete blocks are called for or indicated on the Drawings:
    - a. Install standard units for base course.
    - b. Install acoustical concrete blocks with open end of the cavities pointing downward and slots exposed to area where sound absorption is desired.
    - c. Install standard concrete masonry units and bullnose concrete masonry units in running bond with acoustical concrete blocks around the perimeter of openings and where embedded items penetrate walls.
- D. Control joints:
- 1. Provide vertical control joints at intervals of not more than 48 horizontal feet of continuous exterior wall unless otherwise shown on the Drawings.
  - 2. Extend control joint completely through masonry wall section.
  - 3. Provide control joint gasket between concrete masonry units.
  - 4. Provide smooth dowel bar with dowel cap between fully grouted concrete masonry bond beam units.
  - 5. Fill the joint opening on each side of masonry wall with joint sealant.
- E. Isolation joints:
- 1. Provide vertical isolation joints where shown on the Drawings.

2. Extend isolation joint completely through masonry wall section.
  3. Provide joint stabilization anchors set in fully grouted cores between concrete masonry units.
  4. Fill the joint opening on each side of masonry wall with joint sealant.
- F. Joint reinforcing:
1. Place horizontal joint reinforcing in every second course of masonry walls.
  2. Place horizontal joint reinforcing in the first and second course above and below openings.
  3. Extend joint reinforcing not less than 24 inches beyond each side of opening.
  4. Place prefabricated sections of joint reinforcing at corners and wall intersections to maintain continuity at corners.
  5. Lap joint reinforcing a minimum of 6 inches at splice locations.
  6. Do not extend joint reinforcing through vertical masonry control joints or isolation joints.
- G. Reinforcement:
1. Provide reinforcement as shown on the Drawings, fully embedded in grout and not in mortar or mortar joints.
  2. Provide required metal accessories to ensure adequate alignment of steel during grouting operations.
- H. Anchorage: Provide ties or anchors from face masonry to back up construction.
1. For masonry walls which abut or are backed by concrete, provide dovetail anchors:
    - a. Embed vertical dovetail anchor slots in concrete spaced horizontally at not more than 24 inches on center.
    - b. Place triangular wire anchors in slots spaced at vertical intervals of 16 inches on center.
  2. For masonry walls backed by masonry, provide horizontal joint reinforcing with integral ties.
- I. Weep holes:
1. Provide weep holes in vertical joints of exterior masonry above openings and at base of walls and sills.
  2. Space weep holes at a maximum of 32 inches on center.
  3. Omit mortar in vertical joints at weep hole locations.
  4. Provide a piece of 1/4-inch cotton cord 12 inches long at each weep hole location.
- J. Flashing:
1. Provide flashing in exterior masonry above openings and at the base of walls and sills.
  2. Terminate flashing within the wall 8 inches above the base in a backing masonry mortar joint or a reglet cast into the concrete backup.
- K. Bearing strips:
1. Attach bearing strips to the top of loadbearing walls which support a cast in place concrete slab.

2. Position bearing strip such that it is flush with the interior face of the masonry wall.

### 3.6 JOINERY

- A. General: On all joints exposed to the weather, tool and make smooth, solid, and watertight.
- B. Joint Pattern:
  1. For brick, concrete masonry units, glass masonry units and ceramic glazed structural clay facing tile:
    - a. Provide a smooth uniform concave tooled mortar surface without voids for exposed areas.
    - b. Provide struck joints for all other areas.
  2. For cut stone:
    - a. Rake joints clean of mortar to a depth of 3/8-inch.
    - b. Point joints with joint sealant of a color to match the stone.

### 3.7 GROUTING

- A. Placement:
  1. Place grout within 1½ hours from introducing water in the mixture and prior to initial set.
  2. Comply with maximum grout pour height and minimum grout space dimensions for grouting cells of hollow units for fine grout per Table 7 of ACI 530.1 Specification for Masonry Structures, latest edition.
  3. Limit grout lifts to maximum height of 5 feet.
  4. Provide cleanouts for grout pours over 5 feet. Locate cleanout openings in face shells of bottom course units containing dowels or vertical reinforcing and at maximum spacing of 32 inches for solidly grouted walls.
  5. Verify that vertical and horizontal reinforcement is in proper position and adequately secured before beginning pours.
  6. Place each grout pour continuously and consolidate immediately. Do not interrupt placements more than 1½ hours.
  7. Level off grout 1-inch below top of bed joint to create shear key between grout lifts.
  8. Place grout for spanning elements in single, continuous pour.
- B. Consolidation:
  1. Consolidate grout placements 12 inches or less in height by mechanical vibration or by puddling.
  2. Consolidate grout placements exceeding 12 inches in height by mechanical vibration and reconsolidate by mechanical vibration after initial water loss and settlement has occurred.
  3. Do not overconsolidate.

END OF SECTION

SECTION 05 50 00  
METAL FABRICATIONS

PART 1 - GENERAL

1.1 SUMMARY

- A. Provide miscellaneous metal work as shown on the Drawings, as specified herein, and as needed for a complete and proper installation.
- B. Related work:
  - 1. Documents affecting work under this Section include, but are not necessarily limited to, General Conditions, Supplementary Conditions, and Division 01 - General Requirements of these Specifications.
- C. References:
  - 1. Reserved.

1.2 SUBMITTALS

- A. Shop Drawing Submittals – None Required.
- B. Operation and Maintenance Manuals – None Required.
- C. Certificates and Guarantees – None Required.
- D. Lubricants – None Required.
- E. Spare Parts – None Required.
- F. Comply with pertinent provisions of Section 01 33 01.

1.3 QUALITY ASSURANCE

- A. Perform shop and/or field welding required in connection with the work of this Section in strict accordance with pertinent recommendations of the American Welding Society.
  - 1. Structural Welding Code Steel: D1.1.
  - 2. Structural Welding Code Aluminum: D1.2.
  - 3. Structural Welding Code Sheet Steel: D1.3.
  - 4. Structural Welding Code Stainless Steel: D1.6.

1.4 DELIVERY, STORAGE, AND HANDLING

- A. Comply with pertinent provisions of Section 01 66 11.

1.5 SITE CONDITIONS – Reserved.

1.6 MAINTENANCE – Reserved.

## PART 2 - PRODUCTS

### 2.1 MATERIALS

- A. In fabricating items which will be exposed to view, limit materials to those which are free from surface blemishes, pitting, rolled trade names, and roughness.
- B. Comply with pertinent provisions of the following standards, latest edition.
1. Aluminum castings: ASTM B26.
  2. Aluminum sheet and plate: ASTM B209, Alloy 6061-T6.
  3. Aluminum drawn seamless tubes: ASTM B210, Alloy 6063-T5.
  4. Aluminum extrusions: ASTM B221, Alloy 6063-T6.
  5. Aluminum seamless pipe: ASTM B241, Alloy 6061-T6.
  6. Aluminum forgings: ASTM B247, Alloy 6061-T6.
  7. Aluminum structural shapes: ASTM B308, Alloy 6061-T6.
  8. Aluminum structural pipe and tube: ASTM B429, 6061-T6.
  9. Aluminum tread plate: ASTM B632, Alloy 6061-T6.
  10. Steel plates, shapes, and bars: ASTM A36.
  11. Steel plates to be bent or cold-formed: ASTM A283, Grade C.
  12. Steel tubing (hot-formed, welded, or seamless): ASTM A501, Grade B.
  13. Steel bars and bar-size shapes: ASTM A663, Grade 65, or ASTM A36.
  14. Cold-finished steel bars: ASTM A108.
  15. Cold-rolled carbon steel sheets: ASTM A1008.
  16. Galvanized carbon steel sheets: ASTM A653, with G90 zinc coating.
  17. Stainless steel bars, angles and shapes: ASTM A276, Type 316 (Type 316L for welded connections).
  18. Welded stainless steel mechanical tubing: ASTM A554, Type 316 (Type 316L for welded connections).
  19. Stainless steel fasteners: ASTM F593 and F594, Type 316.
  20. Stainless steel wire fabric, sheet and plates: ASTM A240, Type 316 (Type 316L for welded connections).
  21. Gray iron castings: ASTM A48.
  22. Malleable iron castings: ASTM A47.
  23. Steel pipe: ASTM A53, Grade A, Schedule 40, black finish unless otherwise noted.
  24. Concrete inserts: Threaded or wedge type galvanized ferrous castings of malleable iron complying with ASTM A27.

### 2.2 ANCHORS AND FASTENERS

- A. Provide Type 316 stainless steel anchor bolts, threaded rods, bolts, nuts, screws, staples, washers, rivets, lock nuts, nails, pins, hooks, clamps, and all other metal fasteners.

- B. Post installed mechanical anchors:
1. Provide Type 316 stainless steel wedge, sleeve and drop-in expansion anchors of size and number required for the particular use.
  2. Furnish anchors suitable for installation in cracked and uncracked base materials to resist short and long-term sustained loading.
  3. Acceptable manufacturers:
    - a. Simpson Strong-Tie Company, Inc.
    - b. Hilti, Inc.
    - c. ITW Redhead.
    - d. Or equal.
- C. Post installed adhesive anchors:
1. Provide Type 316 stainless steel threaded rods set in place with a cartridge type, two-component, high solids epoxy adhesive system dispensed and mixed through a static mixing nozzle supplied by the manufacturer.
  2. Concrete base material: Furnish material suitable for anchorage of threaded rods in cracked and uncracked concrete to resist long-term sustained loading, tested and qualified in accordance with the International Code Council Acceptance Criteria for Post-installed Adhesive Anchors in Concrete Elements (AC308).
    - a. Acceptable products:
      - (1) Hilti Inc., HIT-RE 500-SD.
      - (2) Simpson Strong-Tie, SET-XP.
      - (3) No substitution permitted.
  3. Solid grouted masonry base material: Furnish material suitable to resist long-term sustained loading, tested and qualified in accordance with the International Code Council Acceptance Criteria for Adhesive Anchors in Concrete and Masonry Elements (AC58).
    - a. Acceptable products:
      - (1) Hilti Inc., HIT-HY 150 MAX.
      - (2) Simpson Strong-Tie, ET Epoxy-Tie.
      - (3) No substitution permitted.
  4. Hollow masonry base material: Furnish material suitable to resist long-term sustained loading, tested and qualified in accordance with the International Code Council Acceptance Criteria for Adhesive Anchors in Unreinforced Masonry Elements (AC60). Provide screen tubes for anchorage of threaded rods in hollow concrete masonry, hollow brick masonry and unreinforced masonry applications.
    - a. Acceptable products:
      - (1) Hilti Inc., HIT-HY 20.
      - (2) Simpson Strong-Tie, ET Epoxy-Tie.
      - (3) No substitution permitted.
- D. Provide Type 304 stainless steel screw anchors of size and number required for the particular use.
1. Acceptable products:
    - a. Powers Fasteners, Tapper Screw Anchor.

- b. Or equal.

## 2.3 OTHER MATERIALS

- A. Provide other materials, not specifically described but required for a complete and proper installation, as selected by the Contractor subject to the approval of the Engineer.

## 2.4 FABRICATION

- A. Except as otherwise shown on the Drawings or the approved Shop Drawings, use materials of size, thickness, and type required to produce reasonable strength and durability in the work of this Section.
- B. Fabricate with accurate angles and surfaces which are true to the required lines and levels, grinding exposed welds smooth and flush, forming exposed connections with hairline joints, and using concealed fasteners wherever possible.
- C. Prior to shop painting or priming, properly clean metal surfaces as required for the applied finish and for the proposed use of the item.
- D. On surfaces inaccessible after assembly or erection, apply two coats of the specified primer. Change color of second coat to distinguish it from the first.

## 2.5 ALUMINUM LADDERS AND STAIRS

- A. Fabricate of structural shapes in accordance with details shown on the Drawings.
  - 1. Provide stainless steel bolts, nuts, washers, and other fasteners.
  - 2. Stairway treads: Pressure locked rectangular bar type with corrugated nosing.
  - 3. Acceptable manufacturers:
    - a. Breuer Metal Craftsmen, Beaver Dam, WI.
    - b. Or equal.

## PART 3 - EXECUTION

### 3.1 SHOP TREATMENT OF METAL SURFACES

- A. Clean ferrous metal surfaces, except stainless steel and work to be galvanized, by sandblasting to bare metal in accordance with the Steel Structures Painting Council Specifications (SSPC) SP-10 and shop prime as specified under the Section 09 90 00.
  - 1. Do not shop prime or paint contact surfaces which are to be field bolted or welded.

- B. Clean cast iron surfaces by sandblasting to bare metal in accordance with SSPC SP-6 and shop paint with a two-coat system of bituminous paint using Tnemec 46-465 Heavy Duty Black, or equal.
- C. Clean stainless steel surfaces to remove oil, grease, hand and finger prints, and any other surface contaminants after fabrication and passivate in a 20 percent nitric acid solution.
  - 1. Protect polished stainless steel surfaces with removable plastic coatings or coverings during delivery, handling, and installation.
- D. Provide standard mill finish for aluminum surfaces unless clear anodized or color finish is otherwise specified.
  - 1. Provide caustic etch and anodic oxide treatment for aluminum surfaces to be anodized, conforming to the Aluminum Association Standard AA-M12C22A.
- E. Properly clean copper and bronze metal surfaces and shop coat with a high quality clear finishing lacquer.
- F. Shop paint non-ferrous metal surfaces which will contact dissimilar metals, mortar, concrete, plaster, or any other corrosive material with one heavy coat of bituminous paint, using Tnemec 46-465, or equal.

### 3.2 COORDINATION

- A. Coordinate as required with other trades to assure proper and adequate provision in the work of those trades for interface with the work of this Section.

### 3.3 INSTALLATION

- A. General:
  - 1. Set work accurately into position, plumb, level, true, and free from rack.
  - 2. Anchor firmly into position.
  - 3. Where field welding is required, comply with AWS recommended procedures of manual-shielded metal-arc welding for appearance and quality of weld and for methods to be used in correcting welding work.
  - 4. Grind exposed welds smooth and touch-up shop prime coats.
  - 5. Do not cut, weld, or abrade surfaces which have been hot-dip galvanized after fabrication and which are intended for bolted or screwed field connections.
  - 6. Immediately after erection, clean the field welds, bolted connections, and abraded areas of shop priming. Paint the exposed areas with same material used for shop priming.
- B. Post installed anchors:
  - 1. Perform anchor installation in accordance with manufacturer's instructions.



2. Identify location of reinforcing steel and other embedded items prior to drilling holes for anchors. Do not cut or damage reinforcing steel, prestressed steel tendons, piping, conduits or other embedded items. Notify the Engineer of reinforcing steel or other embedded items encountered during drilling.
3. Use drill type, bit type and diameter recommended by the anchor manufacturer.
4. Drill holes perpendicular to surface of concrete or masonry after concrete, mortar or grout has achieved full design strength.
5. Clean holes to remove loose material and drilling dust prior to installation of anchors.
6. Mechanical anchors:
  - a. Protect threads from damage during anchor installation.
  - b. Use a torque wrench to set anchors to manufacturer's recommended torque.
7. Adhesive anchors:
  - a. Install screen tubes for anchorage of threaded rods in hollow masonry base materials.
  - b. Follow manufacturer's recommendations to ensure proper mixing of adhesive components.
  - c. Inject adhesive into holes proceeding from the bottom of the hole and progressing toward the surface in such a manner as to avoid introduction of air pockets in the adhesive.
  - d. Inject sufficient adhesive in the hole to ensure that the annular gap is filled to the surface. Remove excess adhesive from the surface. Shim anchors with suitable device to center the anchor in the hole. Do not disturb or load anchors before manufacturer's specified cure time has elapsed.
  - e. Observe manufacturer's recommendations with respect to installation temperatures.
8. Provide the following minimum embedment, edge distance and spacing unless indicated otherwise by the anchor manufacturer's instructions or shown otherwise on the Drawings:

Anchor Type	Min Embedment (Bolt Diameters)	Min Edge Distance (Bolt Diameters)	Min Spacing (Bolt Diameters)
Wedge	9	6	10
Sleeve	4	6	12
Drop-In	4	6	12
Adhesive	9	9	14

END OF SECTION

SECTION 07 92 00

JOINT SEALANTS

PART 1 - GENERAL

1.1 SUMMARY

- A. Provide joint sealants as shown on the Drawings, as required by other Sections, as specified herein, and as needed for a complete and proper installation.
- B. Related work:
  - 1. Documents affecting work of this Section include, but are not necessarily limited to, General Conditions, Supplementary Conditions, and Division 01 – General Requirements of these Specifications.
- C. References:
  - 1. Reserved.

1.2 SUBMITTALS

- A. Shop Drawing Submittals – None Required.
- B. Operation and Maintenance Manuals – None Required.
- C. Certificates and Guarantees – None Required.
- D. Lubricants – None Required.
- E. Spare Parts – None Required.

1.3 QUALITY ASSURANCE

- A. Use adequate numbers of skilled workmen who are thoroughly trained and experienced in the necessary crafts and who are completely familiar with the specified requirements and the methods needed for proper performance of the work of this Section.

1.4 DELIVERY, STORAGE, AND HANDLING

- A. Comply with pertinent provisions of Section 01 66 11.

1.5 SITE CONDITIONS – Reserved.

1.6 MAINTENANCE – Reserved.

## 1.7 DEFINITION

- A. The terms sealant and caulk shall be considered synonymous whenever and wherever used in Contract Documents.

## PART 2 - PRODUCTS

### 2.1 SEALANTS

- A. Type A – Silicone Sealant:
1. Low modulus silicone sealant conforming to the latest requirements of ASTM C920, Type S, Grade NS, Class 100/50, Uses NT & M.
  2. Acceptable products:
    - a. Silpruf LM SCS2700 by GE Silicones.
    - b. Dow Corning 790 Silicone Building Sealant by Dow Corning.
    - c. Or equal.
  3. Color as selected by Engineer.
- B. Type B – Acrylic Sealant:
1. Acrylic latex plus silicone sealant conforming to the latest requirements of ASTM C834, Type OP, Grade NF single component, paintable.
  2. Acceptable products:
    - a. AC20+Silicone by Pecora Corporation.
    - b. DAP ALEX Plus Acrylic Latex Caulk Plus Silicone by DAP.
    - c. Or equal.
- C. Type C – Polyurethane Sealant (General Purpose):
1. Polyurethane sealant conforming to the latest requirements of ASTM C920, Type S, Grade NS, Class 25, Uses NT, M, A, G and O.
  2. Acceptable products:
    - a. DynaTrol I-XL by Pecora Corporation.
    - b. Sikaflex-1a by Sika Concrete Restoration Systems.
    - c. Sonolastic NP1 by Degussa Construction Chemicals.
    - d. Or equal.
- D. Type D – Polyurethane Sealant (Continuous Water Immersion):
1. Polyurethane sealant approved by manufacturer for continuous water immersion conforming to latest requirements of ASTM C920, Type S, Grade P or NS, Class 25, Uses I, M and A.
  2. Acceptable products:
    - a. Sikaflex-1a by Sika Concrete Restoration Systems.
    - b. Sikaflex-1 CSL by Sika Concrete Restoration Systems.
    - c. Or equal.
- E. Primer: Non-staining type as recommended by sealant manufacturer.

- F. Joint Backing: Flexible, compressible, closed cell polyethylene compatible with sealant.
- G. Bond Breaker: Pressure sensitive tape as recommended by sealant manufacturer.
- H. Joint cleaner: Non-corrosive and non-staining type as recommend by sealant manufacturer and compatible with joint forming material.

### PART 3 - EXECUTION

#### 3.1 EXAMINATION

- A. Verify substrate surfaces and joint openings are ready to receive work.
- B. Verify that joint backing and release tapes are compatible with sealant.

#### 3.2 INSTALLATION

- A. Remove loose materials and foreign matter which might impair adhesion of sealant.
- B. Clean and prime joints in accordance with sealant manufacturer's instructions.
- C. Protect elements surrounding the work from damage or disfigurement.
- D. Install in accordance with sealant manufacturer's instructions.
- E. Measure joint dimensions and size joint backers to achieve width to depth ratios, neck dimension, and surface bond area as recommended by sealant manufacturer.
- F. Install bond breaker where joint backing is not used.
- G. Install sealant free from air pockets, foreign embedded matter, ridges and sags.
- H. Tool joints.

#### 3.3 CLEANING

- A. Clean adjacent soiled surfaces in accordance with sealant manufacturer's instructions.

#### 3.4 SCHEDULE

- A. Contracting joints in concrete: Type C.

- B. Exposed joints between precast concrete roof deck units and precast concrete roof deck units and adjacent work: Type B.
- C. Interior and exterior joints between precast concrete roof deck units and adjacent work: Type A.
- D. Control joints in masonry, and between masonry and adjacent work: Type A, color as selected by Owner.
- E. Joints between interior and exterior frames of doors, windows, wall panels and other device set in masonry: Type A, color as selected by Owner.
- F. Exterior joints for which no other sealant type is indicated: Type C, color as selected by Owner.
- G. Interior joints for which no other sealant type is indicated: Type B, color as selected by Owner.
- H. Water immersion joints for which no other sealant type is indicated: Type D.

END OF SECTION

SECTION 09 90 00  
PAINTING AND COATING

PART 1 - GENERAL

1.1 SUMMARY

- A. Paint and finish exposed surfaces using the combination of materials listed on Painting Schedule in Part 3 of this Section, as specified herein, and as needed for a complete and proper installation.
- B. Related work:
  - 1. Documents affecting work of this Section include, but are not necessarily limited to, General Conditions, Supplementary Conditions, and Division 01 - General Requirements of these Specifications.
  - 2. Priming or priming and finishing of certain surfaces may be specified to be factory-performed or installer-performed under pertinent other Sections.
- C. References:
  - 1. Reserved.
- D. Work included:
  - 1. All new interior piping, masonry, and concrete.
  - 2. New equipment without a finished coating.
  - 3. Any damaged or marred existing surfaces and pipes.
- E. Work not included:
  - 1. Existing surfaces, equipment and materials not impacted by new construction.
  - 2. Anodized aluminum, stainless steel, chromium plate, and similar finished materials will not require painting under this Section except as may be so specified in other Sections of these Specifications.
  - 3. Do not paint moving parts of operating units; mechanical or electrical parts such as valve operators; linkages; sensing devices; and motor shafts, unless otherwise specified.
  - 4. Do not paint over required labels or equipment identification, performance rating, name, or nomenclature plates.
  - 5. Do not paint explosion-proof light fixtures, junction boxes, fittings or accessories.
- F. Definitions:
  - 1. "Paint" as used herein, means coating systems materials including primers, emulsions, epoxy, enamels, sealers, fillers, and other applied materials whether used as prime, intermediate, or finish coats.

## 1.2 SUBMITTALS

- A. Shop Drawing Submittals:
  - 1. Materials list of items proposed to be provided under this Section.
  - 2. Manufacturer's specifications and other data needed to prove compliance with the specified requirements.
  - 3. Color charts for selection of colors by the Owner.
- B. Operation and Maintenance Manuals – None Required.
- C. Certificates and Guarantees:
  - 1. Contractor Qualifications - Provide certification of previous experience and equipment necessary to apply/install the specified painting and coating systems.
- D. Lubricants – None Required.
- E. Spare Parts – None Required.
- F. Comply with pertinent provisions of Section 01 33 01.

## 1.3 QUALITY ASSURANCE

- A. Use adequate numbers of skilled workmen who are thoroughly trained and experienced in the necessary crafts and who are completely familiar with the specified requirements and the methods needed for proper performance of the work of this Section.
- B. Paint coordination:
  - 1. Within 35 calendar days after the Contractor has received the Engineer's Notice to Proceed, arrange a conference with a technical representative of the paint manufacturer, the Engineer, the Contractor, and the Owner to:
    - a. review the paint systems to be used;
    - b. select colors;
    - c. review painting procedures; and
    - d. establish painting schedule.
  - 2. Notify the equipment manufacturers and miscellaneous metals fabricators of the correct shop primer to be used to assure compatibility of the total coating system.
  - 3. Review other Sections of these Specifications as required, verifying the prime coats to be used and assuring compatibility of the total coating system.
  - 4. Provide barrier coats over non-compatible primers, or remove the primer and reprime as required.
  - 5. Notify the Engineer in writing of anticipated problems in using the specified coating systems over prime-coatings supplied under other Sections.

#### 1.4 DELIVERY, STORAGE, AND HANDLING

- A. Comply with pertinent provisions of Section 01 66 11.
  - 1. Store materials in a safe, ventilated location.
  - 2. Remove oily rags, waste, etc. every day and do not allow to accumulate under any circumstances.
  - 3. Take precautions to prevent spontaneous combustion.

#### 1.5 SITE CONDITIONS

- A. Do not apply paints when the temperature of surfaces to be painted and the surrounding air temperatures are below 50 degrees F, unless otherwise permitted by the manufacturers' printed instructions as approved by the Engineer.
- B. Weather conditions:
  - 1. Do not apply paint in snow, rain, fog, or mist; or when the relative humidity exceeds 85 percent; or to damp or wet surfaces, unless otherwise permitted by the manufacturers' printed instructions as approved by the Engineer.
  - 2. Applications may be continued during inclement weather only within the temperature limits specified by the paint manufacturer as being suitable for use during application and drying periods.

#### 1.6 MAINTENANCE

- A. Upon completion of the work of this Section, deliver to the Owner an extra stock equaling 10 percent, but not less than one gallon, of each color, type, and gloss of paint used in the Work, tightly sealing each container, and clearly labeling with contents and location where used.

### PART 2 - PRODUCTS

#### 2.1 PAINT MATERIALS

- A. Acceptable materials:
  - 1. The Painting Schedule in Part 3 of this Section is based on products of the Tnemec Company, Inc., except where another manufacturer is named for a specific application.
  - 2. Products of other manufacturers may be submitted for review in accordance with provisions of the Contract. These products will be considered substitutions.
  - 3. Where products are proposed other than those specified by name and number in the Painting Schedule, provide submittal required by Article 1.2 of this Section and a new painting schedule compiled in the same format used for the Painting Schedule included in this Section.



- B. Undercoats:
  - 1. Provide undercoat paint produced by the same manufacturer as the finish coat.
  - 2. Insofar as practicable, use undercoat and finish coat material as parts of a unified system of paint finish.
- C. Provide all paints and materials supplied by one manufacturer.

## 2.2 APPLICATION EQUIPMENT

- A. For application of the approved paint, use only such equipment as is recommended for application of the particular paint by the manufacturer of the particular paint, and as approved by the Engineer.
- B. Prior to use of application equipment, verify that the proposed equipment is actually compatible with the material to be applied, and that integrity of the finish will not be jeopardized by use of the proposed equipment.

## 2.3 OTHER MATERIALS

- A. Provide other materials, not specifically described but required for a complete and proper installation, as selected by the Contractor subject to the approval of the Engineer.

# PART 3 - EXECUTION

## 3.1 SURFACE CONDITIONS

- A. Examine the areas and conditions under which work of this Section will be performed.
  - 1. Correct conditions detrimental to timely and proper completion of the Work.
  - 2. Do not proceed until unsatisfactory conditions are corrected.

## 3.2 MATERIALS PREPARATION

- A. General:
  - 1. Mix and prepare paint materials in strict accordance with the manufacturers' recommendations as approved by the Engineer.
  - 2. When materials are not in use, store in tightly covered containers.
  - 3. Maintain containers used in storage, mixing, and application of paint in a clean condition, free from foreign materials and residue.

- B. Stirring:
1. Stir materials before application, producing a mixture of uniform density.
  2. Do not stir into the material any film which may form on the surface, but remove the film and, if necessary, strain the material before using.

### 3.3 SURFACE PREPARATION

- A. General:
1. Perform preparation and cleaning procedures in strict accordance with the paint manufacturers' recommendations as approved by the Engineer.
  2. Remove removable items such as hardware, accessories, nameplates, fixtures which are in place and are not scheduled to receive paint finish; or provide surface applied protection prior to surface preparation and painting operations.
  3. Following completion of painting in each space or area, reinstall the removed items by using workmen who are skilled in the necessary trades.
  4. Clean each surface to be painted prior to applying paint or surface treatment.
  5. Schedule the cleaning and painting so that dust and other contaminants from the cleaning process will not fall onto wet newly painted surfaces and other surfaces.
- B. Preparation of wood surfaces:
1. Fill, prime and clean wood surfaces until free from dirt, oil, and other foreign substance.
  2. Smooth finished wood surfaces exposed to view, using the proper sandpaper to produce a uniformly smooth and unmarred wood surface.
- C. Preparation of metal surfaces:
1. Thoroughly clean surfaces until free from dust, dirt, black oxide, scale, rust, paint, oil, and grease in accordance with The Society for Protective Coatings (SSPC) Specifications required in Paint Schedule.
  2. On galvanized surfaces, prepare in accordance with the methods outlined in ASTM D 6386-99 Standard Practice for Preparation of Zinc (Hot Dipped Galvanized) Coated Iron and Steel Product and Hardware Surfaces for Painting.
- D. Preparation of concrete and masonry surfaces:
1. Clean concrete and masonry surfaces by the methods outlined in SSPC SP-13, Surfaces Preparation of Concrete. Use wire brushing, scraping, high pressure water cleaning, mechanical abrasion, blast tracking, or sandblasting as necessary and as required on the Paint Schedule. Vacuum clean, air blast clean or water clean to remove dirt, dust and loose material. Steam clean or detergent clean to remove oils and grease, efflorescence, stains and contaminants.
  2. Allow new concrete and masonry to cure a minimum of 28 days before paint application.
  3. Level protrusions and mortar spatter.

- E. Preparation of Ductile and Cast Iron Surfaces:
1. Solvent clean in accordance with NAPF 500-03-01 Surface Preparations Standard for Solvent Cleaning.
  2. Abrasive Blast Cleaning of Ductile and Cast Iron:
    - a. For external pipe surfaces, abrasive blast clean in accordance with NAPF 500-03-04 Surface Preparations Standards for Abrasive Blast Cleaning – External Pipe Surfaces.
    - b. For internal pipe surfaces, abrasive blast clean in accordance with NAPF 500-03-04 Surface Preparations Standards for Abrasive Blast Cleaning – Internal Pipe Surfaces.

### 3.4 PAINT APPLICATION

- A. General:
1. Touch-up shop-applied prime coats which have been damaged, and touch-up bare areas prior to start of finish coats application.
  2. Notify the Engineer or the Owner of the completion of each coat.
    - a. Do not apply additional coats until the completed coat has been inspected and approved.
    - b. Only the inspected and approved coats of paint will be considered in determining the number of coats applied.
  3. Do all necessary touching up after other mechanics have finished and leave entire work in a neat and clean condition.
  4. Do not leave paint spots on glass, hardware, floors, or other finished work.
  5. If required by the Engineer, tint by mixing a small amount of white paint of the exact same type with any or all paint used prior to the final coat so that the area covered by the application of each coat is readily discernible.
  6. Provide an approved gauge for determining the mil thickness of the paint on a surface.
- B. Drying:
1. Allow sufficient drying time between coats, modifying the period as recommended by the material manufacturer to suit adverse weather conditions.
- C. Brush applications:
1. Apply the painting materials by brush and work the brush coats onto the surface in an even film.
  2. Cloudiness, spotting, holidays, laps, brush marks, runs, sags, ropiness, and other surface imperfections will not be acceptable.
- D. Spray application:
1. Except as specifically otherwise approved by the Engineer, confine spray application to metal and similar surfaces where hand brush work would be inferior.

2. Where spray application is used, apply each coat to provide the hiding equivalent of brush coats.
  3. Do not double back with spray equipment to build up film thickness of two coats in one pass.
  4. Protect other surfaces from over spray.
- E. For completed work, match the approved texture, color, and coverage. Remove, refinish, or repaint work not in compliance with the specified requirements.

### 3.5 PAINTING SCHEDULE

		<u>Dry Film - mils</u>
A.	Steel, iron, galvanized and non-ferrous metal; tanks, pipes, conduits, electrical boxes, and equipment:	
1.	Exterior, non-immersion: System Series 1075 Endura-Shield.	
a.	Surface preparation: SSPC-SP6 Commercial Blast Cleaning for ferrous metal; ASTM D 6386-99 for galvanized; scarify non-ferrous metal; NAPF 500-03 for cast & ductile iron.	
b.	1 <sup>st</sup> Coat: Tnemec Series 1 Omnithane.	2.5 - 4.0
c.	2 <sup>nd</sup> Coat: Tnemec Series N69-Color Hi-Build Epoxoline II. (2-3 mil dft for galvanized and non-ferrous metal.)	4.0 - 6.0
d.	3 <sup>rd</sup> Coat: Tnemec Series 1075-Color Endura-Shield II.	<u>2.0 - 3.0</u> 8.5 - 13.0
2.	Interior, non-immersion: System Series N69 Hi-Build Epoxoline II.	
a.	Surface preparation: SSPC-SP6 Commercial Blast Cleaning for ferrous metal; ASTM D 6386-99 for galvanized; scarify non-ferrous metal; NAPF 500-03 for cast & ductile iron.	
b.	1 <sup>st</sup> Coat: Tnemec Series 1 Omnithane.	2.5 - 4.0
c.	2 <sup>nd</sup> Coat: Tnemec Series N69-Color Hi-Build Epoxoline II. (2-3 mil dft for galvanized and non-ferrous metal.)	4.0 - 6.0
d.	3 <sup>rd</sup> Coat: Tnemec Series N69-Color Hi-Build Epoxoline II. (2-3 mil dft for galvanized and non-ferrous metal.)	<u>4.0 - 6.0</u> 10.5 - 16.0
3.	Immersion, or subject to splash or spray of potable water: System Series N140 Pota-Pox Plus.	
a.	Surface Preparation: SSPC-SP10 Near White Metal Blast Cleaning. NAPF 500-03 for cast & ductile iron.	
b.	1 <sup>st</sup> Coat: Tnemec Series 1 Omnithane.	2.5 - 4.0

(04/12)

	<u>Dry Film - mils</u>
c. 2 <sup>nd</sup> Coat: Tnemec Series N140-15BL Tank White Pota-Pox Plus.	3.0 - 5.0
d. 3 <sup>rd</sup> Coat: Tnemec Series N140-1255 Beige Pota-Pox Plus.	3.0 - 5.0
e. 4 <sup>th</sup> Coat: Tnemec Series N140-15BL Tank White Pota-Pox Plus.	<u>3.0 - 5.0</u>
	11.5 - 19.0
4. High temperature surfaces: System Series 39 Silicone Aluminum.	
a. Surface Preparation: SSPC-SP10 Near White Metal Blast Cleaning.	
b. 1 <sup>st</sup> Coat: Tnemec Series 39-1261 Silicone Aluminum.	1.0 - 1.5
c. 2 <sup>nd</sup> Coat: Tnemec Series 39-1261 Silicone Aluminum.	<u>1.0 - 1.5</u>
	2.0 - 3.0
B. Concrete:	
1. Interior, exposed except floor: System Series N69 Hi-Build Epoxoline II.	
a. Surface Preparation: SSPC SP-13, fill voids with Tnemec Series 218 MortarClad.	
b. 1 <sup>st</sup> Coat: Tnemec Series N69-W6160 Hi-Build Epoxoline II.	(80-100 sq. ft./gal.)
c. 2 <sup>nd</sup> Coat: Tnemec Series N69-Color Hi-Build Epoxoline II.	3.0 - 4.0
d. 3 <sup>rd</sup> Coat: Tnemec Series N69-Color Hi-Build Epoxoline II.	<u>3.0 - 4.0</u>
	(Topcoats) 6.0 - 8.0
2. Interior floor: System #2 – Thin Film 100% Solid Epoxy, Orange peel finish*.	
a. Surface Preparation: Allow new concrete to cure 28 days, verify dryness. Moisture content not to exceed 3 lbs per 1,000 sq. ft. in a 24-hour period. Shot blast or mechanically abrade to remove laitance curing compounds, hardeners, sealers and other contaminants and to create profile. Reference ICRI CSP -3. Fill large holes and voids as recommended by the coating manufacturer.	
b. 1 <sup>st</sup> Coat: Tnemec Series 201 Epoxoprime.	6.0 - 12.0
c. 2 <sup>nd</sup> coat: Tnemec Series 280-color Tneme-Glaze**.	6.0 - 12.0
d. 3 <sup>rd</sup> coat: Tnemec Series 280-color Tneme-Glaze.	<u>6.0 - 12.0</u>
	18.0 - 36.0

\*If a smooth finish is desired, use Series 281 Tneme-Glaze in lieu of Series 280 Tneme-Glaze.

Dry Film - mils

- C. Concrete Block:
1. Interior: System Series N69 Hi-Build Epoxoline II.
    - a. Surface Preparation: Allow new mortar to cure 28 days, level protrusions and mortar spatter.
    - b. 1<sup>st</sup> Coat: Tnemec Series N69-W6160 Hi-Build Epoxoline II. (75-100 sq. ft./gal.)
    - c. 2<sup>nd</sup> Coat: Tnemec Series N69-Color Hi-Build Epoxoline II. 3.0 - 4.0
    - d. 3<sup>rd</sup> Coat: Tnemec Series N69-Color Hi-Build Epoxoline II. 3.0 - 4.0  
(Topcoats) 6.0 - 8.0
- D. Face brick and Concrete Block:
1. Exterior: Water repellant system & Graffiti Shield system. Series V626 Dura-A-Pell GS.
    - a. Surface preparation: Clean and dry.
    - b. 1<sup>st</sup> Coat: Tnemec Series V626 Dura-A-Pell GS.
 

(Brick: 125-150 sq. ft./gal.)  
(CMU: 65 -85 sq. ft./gal.)
    - c. 2<sup>nd</sup> Coat: Tnemec Series 626 Dura-A-Pell GS.
 

(Brick: 125-150 sq. ft./gal.)  
(CMU: 65 -85 sq. ft./gal.)
- E. Insulated pipe:
1. Interior and exterior: System Series 1029 Enduratone.
    - a. Surface Preparation: Clean and dry.
    - b. 1<sup>st</sup> Coat: Tnemec Series 1029 Enduratone. 2.0 - 3.0
    - c. 2<sup>nd</sup> Coat: Tnemec Series 1029 Enduratone. 2.0 - 3.0  
4.0 - 6.0
- F. PVC:
1. Interior: System Series N69 Hi-Build Epoxoline II.
    - a. Surface Preparation: Hand Sand to Scarify.
    - b. 1<sup>st</sup> Coat: Tnemec Series N69-Color Hi-Build Epoxoline II. 2.0 - 3.0
    - c. 2<sup>nd</sup> Coat: Tnemec Series N69-Color Hi-Build Epoxoline II. 2.0 - 3.0  
4.0 - 6.0
  2. Exterior: System Series 1075 Endura-Shield II.
    - a. Surface Preparation: Hand Sand to Scarify.
    - b. 1<sup>st</sup> Coat: Tnemec Series N69-Color Hi-Build Epoxoline II. 2.0 - 3.0
    - c. 2<sup>nd</sup> Coat: Tnemec Series 1075 Endura-Shield II. 2.0 - 3.0  
4.0 - 6.0

### 3.6 EXISTING SURFACES

- A. General:
  - 1. Paint existing structures, equipment, piping, conduit, and appurtenances that are damaged, cut into or marred as part of new construction.
  - 2. Comply with coating manufacturer's recommendations for surface preparation and painting of existing surfaces.
  - 3. Refer to 3.7 Schedule for coating systems.
- B. Containment & Disposal requirements:
  - 1. Dispose of surface preparation debris in accordance with applicable federal, state and local regulations. Refer to SSPC-GUIDE 7 (DIS).

### 3.7 PIPELINE IDENTIFICATION COLORS

- A. Paint pipelines including fittings and valves with the following color scheme:
  - 1. Potable water lines: N/A Match Existing Blue
  - 2. Sewage lines: GR28 Fossil
- B. Provide stenciled flow arrow(s) and names at least once and every 20 feet for the following pipes:
  - 1. Reservoir Outlet.
  - 2. Reservoir Inlet.
  - 3. Low Pressure Zone (PZ6E) Inlet/Outlet.
  - 4. High Pressure Zone (PZ3) Inlet/Outlet.
  - 5. High Zone/Low Zone Transfer.
  - 6. Chorine Analyzer-In Supply.
  - 7. Chorine Analyzer-Out Supply.

END OF SECTION

## SECTION 22 05 53

## IDENTIFICATION FOR PLUMBING PIPING AND EQUIPMENT

## PART 1 - GENERAL

## 1.1 SUMMARY

- A. Provide piping and equipment identification materials, where shown on Drawings, as specified herein, and as needed for a complete and proper installation.
- B. Related work:
  - 1. Documents affecting work of this Section include but are not necessarily limited to General Conditions, Supplementary Conditions, and Division 01 – General Requirements of these Specifications.
  - 2. Plumbing: Division 22.
  - 3. Heating, Ventilating, and Air Conditioning: Division 23.
  - 4. Electrical: Division 26.
- C. Section Includes:
  - 1. Plastic pipe markers.
  - 2. Valve tags.
  - 3. Plastic equipment markers.
  - 4. Piping system color and stenciling.
- D. Identification furnished as part of equipment is specified as part of equipment assembly in other sections and shall comply with requirements of this Section.
- E. Refer to Division 26 sections for identification requirements of electrical and instrumentation work.

## 1.2 REFERENCES

- A. American National Standards Institute (ANSI):
  - 1. A13.1-1996 – Scheme for Identification of Piping Systems.
- B. Federal Specifications (FS).

## 1.3 SUBMITTALS

- A. Product data: Submit manufacturer's technical product data and installation instructions for each identification material and device required. Submit listing of each flow stream identifier with associated color coding.
- B. Samples: Submit samples of each color, lettering style, and other graphic representation required for each identification material or system.



- C. Submit in accordance with Section 01 33 01.

#### 1.4 QUALITY ASSURANCE

- A. Manufacturer's Qualifications: Firms regularly engaged in manufacture of identification devices of types and sizes required.
- B. Regulatory Requirements:
  - 1. ANSI Standards: Comply with ANSI A13.1 for lettering size, length of color field, colors, and viewing angles of identification devices.

### PART 2 - PRODUCTS

#### 2.1 MANUFACTURERS

- A. Allen Systems, Inc.
- B. Brady (W.H.) Company, Signmark Division.
- C. Marking Services, Inc.
- D. Industrial Safety Supply Company, Inc.
- E. Seton Name Plate Corporation.
- F. Or equal.

#### 2.2 MECHANICAL IDENTIFICATION MATERIALS

- A. Provide manufacturer's recommended products as specified for each application.
- B. Where more than one type of identification is specified for an application, selection is Contractor's option, but provide a single selection for each product category.
- C. All bands, markers, and identification materials used in mechanical rooms and process locations shall be rated for exterior application and suitable for withstanding occasional washdown.

#### 2.3 LETTERING AND GRAPHICS

- A. General: Coordinate names, abbreviations, and other designations used in mechanical identification work with corresponding designations shown, specified or scheduled. Provide numbers, lettering, and wording as indicated or if not otherwise indicated, as recommended by manufacturers or required for proper identification, operation, and maintenance of mechanical systems and equipment.

- B. Multiple Systems: Where multiple systems of same generic name are shown and specified, provide identification indicating individual system number as well as service (i.e., Flow Meter FE/FIT 0101, etc.).

## 2.4 PIPES

- A. Small Pipes: For pipe external diameters less than 4 inches (including insulation if any), Provide fiberglass tags (2½-inch by 4-inch square white tags with black lettering with printed embedded lettering with 3/16-inch high letters) affixed to wall or nearby with fastener with flow arrow.
- B. Large Pipes: For pipe external diameter 4 inches and larger (including insulation if any), provide stenciled paint lettering and flow arrows.

## 2.5 VALVE TAGS

- A. HVAC and Plumbing Valve Tags: Provide 19 gauge polished brass valve tags with stamp engraved piping system abbreviation in 1/4-inch high letters, sequenced valve numbers 1/2-inch high, and 5/32-inch hole for fastener.
  - 1. Provide 1½-inch diameter tags except as otherwise indicated.
  - 2. Fill tag engraving with black enamel.
- B. Process Valve Tags: Provide fiberglass valve tags with printed embedded lettering; piping system abbreviation in approximately 3/16-inch high letters; valve P & ID numbers approximately 3/8-inch high; valve name approximately 3/8-inch high, and 5/32-inch hole for fastener.
  - 1. Provide 2½-inch by 4-inch square white tags with black lettering.
- C. Valve Tag Fasteners: Provide solid brass chain (wire link or beaded type) or solid brass S-hooks of sizes required for proper attachment of tags to valves, manufactured specifically for purpose.

## 2.6 EQUIPMENT MARKERS

- A. General: Provide 2-ply, 1/8-inch thick laminated plastic, engraved equipment markers.
  - 1. Color: Black letters on white background.
- B. Nomenclature: Include following, matching terminology on schedules as closely as possible:
  - 1. Equipment name and unit number (i.e., Non-potable Water Pump No. 1).
  - 2. Equipment P & ID Tag No. (i.e., P0601).
- C. Size: Provide approximate 3-inch by 6-inch (minimum) for equipment.
  - 1. 1-inch high letters for equipment tag number.
  - 2. 1/2-inch high letters for descriptive equipment name.

## PART 3 - EXECUTION

### 3.1 GENERAL INSTALLATION REQUIREMENTS

- A. Coordinate: Where identification is to be applied to surfaces requiring insulation, painting or other covering or finish including valve tags in finished mechanical spaces, install identification after completion of covering and painting. Install identification prior to installation of acoustical ceilings and similar removable concealment.

### 3.2 PIPING SYSTEM IDENTIFICATION

- A. Locate pipe markers with arrows and color bands as follows wherever piping is exposed to view in occupied spaces, machine rooms, accessible maintenance spaces (shafts, tunnels, plenums), and exterior non-concealed locations.
  1. Near each valve and control device.
  2. Near locations where pipes pass through walls or floors, ceilings or enter non-accessible enclosures.
  3. At access doors, manholes, and similar access points permitting view of concealed piping.
  4. Near major equipment items and other points of origination and termination.
  5. Spaced intermediately at maximum spacing of 30 ft. along each piping run, except reduce spacing to 20 ft. in congested areas of piping and equipment.
  6. On piping above removable acoustical ceilings, except omit intermediately spaced markers.
- B. Paint piping and equipment per Section 09 90 00.

### 3.3 PROCESS VALVE IDENTIFICATION

- A. General: Install engraved plastic marker or fiberglass tag at each process valve, gate, or flow control device as identified by P&ID tag numbers.

### 3.4 MECHANICAL EQUIPMENT IDENTIFICATION

- A. General: Install engraved plastic laminate sign or plastic equipment marker on or near each major item of mechanical equipment and each operational device, as specified herein if not otherwise specified for each item or device. Provide signs for each unit having equipment P&ID tag number on Drawings or in specifications.
- B. Electrical and Field Instrumentation Equipment: Provide identification tags, signs, or markers in accordance with Division 26.

### 3.5 ADJUSTING AND CLEANING

- A. Adjusting: Relocate any mechanical identification device visually blocked by work of this or other divisions.
- B. Cleaning: Clean face of identification devices and glass frames of valve charts.

PIPING AND EQUIPMENT IDENTIFICATION SCHEDULE TABLE 22 05 53-1				
Flowstream Identifier	Label Color	Pipe Label Text	Pipe Color	Pipe Banding
<b>WATER</b>				
See Note 1	Black (stencil)	Identification in Section 09 90 00	See Note 1	N/A
<b>EQUIPMENT AND INSTRUMENTATION</b>				
See Note 2	Black with white text	Tag Identification in Section 40 91 10	See Note 1	N/A

#### NOTES

1. Provide pipe colors and names as specified in Section 09 90 00.
2. Provide Tags for all Items specified in Section 40 91 10.

END OF SECTION

SECTION 22 11 23.63  
MAGNETIC DRIVE PUMPS

PART 1 - GENERAL

1.1 SUMMARY

- A. Provide one magnetic drive pump for chlorine analyzer (CA-out) influent as shown on the Drawings, as specified herein, and as needed for a complete and proper installation.
- B. Related work:
  - 1. Documents affecting work under this Section include, but are not necessarily limited to, General Conditions, Supplementary Conditions, and Division 01 - General Requirements of these Specifications.
- C. References:
  - 1. Reserved.

1.2 SUBMITTALS

- A. Shop Drawing Submittals:
  - 1. Pump dimension drawings, motor data sheet, pump capacity-head curve, and manufacturer's detailed specifications
- B. Operation and Maintenance Manuals: Submit operation and maintenance manuals in compliance with pertinent provisions of Section 01 78 26.
- C. Certificates and Guarantees – None Required.
- D. Lubricants – None Required.
- E. Spare Parts – None Required.

1.3 QUALITY ASSURANCE – Reserved.

1.4 DELIVERY, STORAGE, AND HANDLING – Reserved.

1.5 SITE CONDITIONS – Reserved.

1.6 MAINTENANCE – Reserved.

## PART 2 - PRODUCTS

### 2.1 GENERAL

- A. Provide magnetic drive pump with the following features:
  - 1. Discharge capacity of 8 gpm when operating against a total discharge head of 16 feet.
  - 2. Maximum discharge head of 21 feet.
  - 3. Closed impeller, Polypropylene or PVDF construction, Viton or EPDM O-ring material with Carbon, PRFE, or ceramic bushing materials.
  - 4. Sealess.
  - 5. Close-coupled, 1/8 horsepower motor, 1.55 amps, suitable for operation on 120 volt, single phase, 60 Hertz A.C.
  - 6. Threaded suction port of 1-inch and discharge port of 0.5 inches.
  - 7. Provide with mounting plate and accessories suitable for mounting on concrete.
  - 8. Acceptable manufacturer: Finish Thompson Model DB3P-M612 or approved equal.

## PART 3 - EXECUTION

### 3.1 INSTALLATION

- A. Install magnetic pump in accordance with manufacturer's recommendations.
- B. Install along trench wall where shown on the Drawings.
- C. Coordinate power supply and control requirements for non-continuous remote operation.

END OF SECTION

SECTION 22 19 13  
PIPE AND PIPE FITTINGS

PART 1 - GENERAL

1.1 SUMMARY

- A. Provide pipe and pipe fittings as shown on the Drawings, as specified herein, and as needed for a complete and proper installation.
- B. Provide labor, materials, tools, chemicals and equipment necessary to perform the pressure and leakage tests and disinfection.
- C. Related work:
  - 1. Documents affecting work under this Section include, but are not necessarily limited to, General Conditions, Supplementary Conditions, and Division 01 - General Requirements of these Specifications.
- D. References:
  - 1. Reserved.

1.2 SUBMITTALS

- A. Shop Drawing Submittals – None Required.
- B. Operation and Maintenance Manuals – None Required.
- C. Certificates and Guarantees – None Required.
- D. Lubricants – None Required.
- E. Spare Parts – None Required.

1.3 QUALITY ASSURANCE

- A. Use adequate numbers of skilled workmen who are thoroughly trained and experienced in the necessary crafts and who are completely familiar with the specified requirements and the methods needed for proper performance of the work of this Section.
- B. Perform shop and field welding required in connection with the work of this Section in strict accordance with pertinent recommendations of the American Welding Society.
  - 1. Provide the services of an independent testing laboratory to take and test weld specimens or otherwise test welds to verify proper welding procedures as required by the Engineer.

#### 1.4 DELIVERY, STORAGE, AND HANDLING

- A. Comply with pertinent provisions of Section 01 66 11.

#### 1.5 SITE CONDITIONS – Reserved.

#### 1.6 MAINTENANCE – Reserved.

### PART 2 - PRODUCTS

#### 2.1 DUCTILE IRON PIPE (DIP) AND FITTINGS

##### A. Flanged joint pipe and fittings:

1. Pipe: Comply with ANSI A21.51, thickness Class 53 with pipe flanges faced and drilled to ANSI Class 125 standard template unless otherwise designated on the Drawings.
2. Fittings: Comply with ANSI A21.10 or ANSI B16.1.
3. Flange gaskets: 1/16-inch thick sheet rubber, full face type or 1/8-inch thick Full Faced American Toruseal flange gasket.
4. Flange bolts, studs, and nuts: Zinc plated type complying with ANSI B16.1.

##### B. Mechanical joint pipe, push-on joint pipe:

1. Pipe: Comply with ANSI A21.51, thickness Class 52 unless otherwise designated on the Drawings.
2. Pipe joints: Comply with ANSI A21.11 for rubber gasket type.
3. Provide restrained joint pipe system, where indicated on the Drawings, that utilizes one of the following methods:
  - a. Lock rings welded into place around pipe barrel.
  - b. Bolted rings installed around pipe barrels that fit inside pipe bells.
  - c. Mechanical joint retainer gland systems that provide locking segments shaped to pipe barrel that do not create stress points on pipe barrel.
    - (1) Do not use setpoint type retainer glands.
  - d. Acceptable products:
    - (1) American Fastite, Flex-ring, Lok-ring, and MJ coupled joint.
    - (2) Clow Tyton Joint – Type A or Type B, and Super - Lock.
    - (3) U.S. Pipe TR-Flex Gripper.
    - (4) Griffin Bolt Lok or Snap Lok.
    - (5) Meg-A-Lug System.
      - i. Series 1100 Megalug for MJ to pipe.
      - ii. Series 1700 Megalug Harness for push on joint.
      - iii. As recommended by manufacturer for connection to existing pipes.

##### C. Fittings:

1. Use ductile iron fittings with mechanical joint complying with ANSI A21.10 or A21.53.
2. Use cement lining complying with ANSI A-21.4, standard thickness.



3. Bolts and nuts:
    - a. Use 316 stainless steel bolts, nuts and washers.
  4. Provide restrained joint type fittings that are compatible with system utilized, as specified by the pipe manufacturer.
- D. Polyethylene sheet: Comply with ANSI/AWWA A 21.5-99/C105:
1. Thickness: linear low-density polyethylene film (minimum 8 mils) or high-density cross laminated polyethylene film (minimum 4 mils).
  2. Markings: The following information will be clearly marked on the sheet at minimum increments of 2-feet along its length:
    - a. Manufacturers name or trademark.
    - b. Year of manufacture.
    - c. Min. film thickness and material type (LLDPE or HDCLPE).
    - d. Applicable range of nominal pipe diameter size(s).
    - e. Warning – Corrosion Protection – Repair any damage.
- E. Conductivity appurtenances:
1. Provide wedges of serrated silicon bronze: or #10-copper cable and tapping devices specifically designed for this purpose.
  2. Use devices provided by the pipe manufacturer.
  3. Standard mechanical joints, field lok, or meg-a-lug do not provide conductivity.

## 2.2 STEEL PIPE AND FITTINGS

- A. Galvanized steel pipe and fittings:
1. Pipe: Comply with ASTM A-53, ASA Schedule 40 weight and wall thickness.
  2. Fittings: Use 150-pound galvanized malleable iron screwed end fittings.

## 2.3 POLYVINYL CHLORIDE PIPE

- A. General:
1. Make polyvinyl chloride (PVC) pipe and fittings of Class 12454B material conforming to ASTM D1784.
- B. PVC pressure pipe and fittings:
1. Use Schedule 80 with a minimum pressure rating of 125 psi at 73 degrees F, conforming to ASTM D1785.
  2. Joints: Use solvent-weld socket type, threaded type, or flanged type.

## 2.4 PLASTIC DRAINAGE PIPE AND FITTINGS

- A. Use either Schedule 40 PVC-DWV or ABS-DWV conforming to ASTM D2661 or D2665 and bearing the National Sanitation Foundation seal of approval.

- B. Fittings: Use molded, fully recessed, socket type with solvent welded joints or O-ring type joints.
  - 1. Special purpose threaded or flanged adapter fittings, couplings, and unions may be used, provided that they are fully recessed and create no restriction to flow greater than conventional fittings.

## 2.5 TUBING

- A. Flexible plastic tubing:
  - 1. Use polyethylene tubing with natural color.
  - 2. Wall thickness: 0.040-inch for 1/4-inch tubing and 0.062-inch for 3/8-inch tubing.
  - 3. Fittings: Use instrumental type for unions, connectors, and caps.
- B. Copper tubing and fittings:
  - 1. Comply with ASTM B88 OR ANSI H23.1.
  - 2. Use Type K soft temper seamless tubing for underground piping.
  - 3. Use Type L rigid hard temper seamless tubing for interior piping.
  - 4. Fittings: Use wrought copper solder type conforming to ANSI B16.22.
    - a. Do not use lead solder for potable water piping.
- C. Stainless steel tubing and fittings:
  - 1. Use Seamless Type 304 tubing conforming to ASTM A269 with wall thickness 0.035-inch.
  - 2. Use high pressure stainless steel compression sleeve type fittings.

## 2.6 WALL SLEEVES AND SEALS

- A. Wall sleeves:
  - 1. Cast iron wall sleeves: Use mechanical joint type with flanges tapped for studs.
  - 2. Steel wall sleeves: Fabricate sleeve from Schedule 40 black steel pipe.
- B. Link seals:
  - 1. Use modular mechanical type consisting of interlocking solid rubber links designed for positive hydrostatic pressure of 20 psig.
    - a. Connect each pair of links by a carbon steel zinc phosphate plated bolt and nut each with a heavy Delrin plastic elongated washer.
  - 2. Acceptable product: "LINK-SEAL" as manufactured by Thunderline Corp. and supplied by Maddock Mechanical Industries, Inc., Chicago, IL, or equal.
- C. Provide integral intermediate water stop wall collars for all wall pipes and sleeves.

## 2.7 FLEXIBLE COUPLINGS AND FLANGED ADAPTERS

- A. Flexible couplings:
  - 1. Use slip ring sleeve type with rubber gaskets, tightening flanges and high strength bolts and nuts, Dresser Style 38, or equal.

2. Provide a minimum of two tie-rods for each coupling to secure the coupling to the adjacent pipe fitting to prevent any compression or tension.
- B. Harnessed flexible rubber expansion joint connectors:
1. Provide full face flanged harnessed flexible rubber expansion joints on both the suction and discharge sides of each booster pump, made of food grade EPDM or food grade neoprene, suitable for potable drinking water with up to 2 mg/l of chlorine, equal to Mercer Rubber Series 450, or equal.
  2. Provide recommended tie-rod size and number for each coupling to secure the coupling to the adjacent flange fittings.
- C. Flanged adapters:
1. Use steel fabricated type, Dresser Style 128, or equal.

## 2.8 RESTRAINED FLANGE ADAPTOR

- A. Provide a ductile iron flange adaptor dual ring system with bolt circles compatible with 125#/Class 150 bolt pattern.
1. Provide adaptor with individual actuated gripping wedges that utilize torque limiting screws to insure proper initial set.
  2. Set screw "only" restraining adaptors are not acceptable.
  3. Provide system that allows joint deflection of up to 5°.
  4. Provide a fluoropolymer coating to the wedge and wedge assembly and powder coating to the restraint body.
- B. Acceptable manufacturers:
1. Series 2100 Megaflange by Ebaa Iron;
  2. Or approved equal.

## PART 3 - EXECUTION

### 3.1 FIELD MEASUREMENTS

- A. Make necessary measurements in the field to assure precise fit of items in accordance with the Drawings.

### 3.2 INSTALLATION OF PIPING

- A. General:
1. Trench, backfill, and compact for the work of this Section in strict accordance with pertinent provisions of Section 31 23 79 of these Specifications.
  2. Install pipe in accordance with pipe manufacturer's recommendations.
  3. Lay pipe by proceeding upgrade with the spigot ends of bell-and-spigot pipe pointing in direction of flow.
  4. Use proper and suitable tools and appliances for safe and convenient handling and installation of piping.
  5. Continually clear interior of the pipe free from foreign material.
  6. Before making pipe joints, clean and dry all surfaces of the pipe to be joined.

7. Use lubricants, primers, and adhesives recommended for the purpose by the pipe manufacturer.
  8. Comply with ASTM D2321 for flexible thermoplastic sewer pipe installation.
  9. Make adequate provision for expansion and contraction of piping.
- B. Water main separation:
1. Whenever water mains are encountered in the course of piping installation, notify the Engineer to determine the construction necessary to comply with the provisions of Sections 31-1.02A of the "Standard Specifications for Water and Sewer Main Construction in Illinois".
- C. Install unions or flanges at piping connections to each piece of equipment, at intervals of not more than 50 feet in straight runs of threaded pipe, at each valve, and wherever else required to disassemble piping for service of fittings, fixtures, equipment and appurtenances.
1. Use unions in piping sizes 3 inches and smaller.
  2. Use flanges in piping sizes larger than 3 inches.
  3. Make connections between ferrous and non-ferrous metal piping with dielectric type insulated unions or flanges.

### 3.3 EXISTING PIPING

- A. The Drawings show the approximate location of existing piping as indicated by available existing records. The proposed work may require crossing, relocating, and in some cases connecting to the existing piping.
- B. Expose carefully the existing piping throughout the area of proposed work.
1. All existing piping to remain undisturbed and in uninterrupted use until such time as a change is approved by Engineer.
  2. Protect exposed piping from freezing during cold weather.
- C. Where new piping is to cross or be connected to existing piping, make a field check to determine whether any conflict will be encountered in laying the new pipe.
1. Adjust the location of new piping, if necessary, as authorized by the Engineer, to avoid conflict with existing piping.
- D. Where new piping is to connect to existing piping, provide all fittings required to complete the connection, and do the work as expeditiously and carefully as possible.
- E. Remove and replace existing pipe, fittings, valves and all appurtenances as required by the Drawings.
1. Adjust valve boxes as required to meet new finished grade elevations.
  2. Provide new valve stems as required to place the operating nut 2 inches from the top of the valve box.
- F. In the event it becomes necessary, in the opinion of the Engineer, to alter the location of an existing pipe to accommodate construction of the new work, relocate or adjust the existing pipe as directed by the Engineer.
1. Additional compensation for this work will be paid for in accordance with the GENERAL CONDITIONS.

### 3.4 PIPING SUPPORTS

#### A. General:

1. Design and provide complete system of supports and anchors for all piping, fittings, valves, fixtures and appurtenances.
2. Absence of pipe supports and details on the Drawings shall not relieve the Contractor of responsibility for providing them.
3. Design pipe support system to withstand dead loads imposed by weight of pipes filled with water plus test pressure and insulation (if required), with a minimum safety factor of 5.
4. Paint pipe supports in accordance with Section 09 90 00.

#### B. Types of support:

1. Piping adjacent to walls may be supported or braced by wall brackets.
2. Floor pipe supports: Use adjustable with floor flanges, pipe stanchion, and saddle where they do not obstruct passage.
3. Ceiling supported pipe hangers: Use adjustable steel clevis type with full diameter hanger rods conforming to the following sizes:

<u>Pipe Size</u>	<u>Minimum Rod Size</u>
1/2" - 2"	3/8"
2-1/2" - 3-1/2"	1/2"
4" - 5"	5/8"
6" - 12"	7/8"
14" - 16"	1"
18" - 20"	1-1/4"
24" - 30"	1-1/2"

#### C. Support spacing:

1. For rigid pipes except PVC pipes:

<u>Pipe Size</u>	<u>Maximum Spacing</u>
1/2" - 2"	6'
2-1/2" - 3-1/2"	8'
4" - 5"	8'
6" - 12"	9'
14" - 16"	9'
18" - 20"	9'
24" - 30"	9'

2. For PVC Schedule 80 pipes:

<u>Pipe Size</u>	<u>Maximum Spacing</u>
3/4" and smaller	continuous rigid support
1" - 1-1/2"	4'
2" - 2-1/2"	5'
3"	6'
4" and larger	7'

3. For flexible hose and tubing:
    - a. Provide continuous support by means of rigid carrier pipes or troughs consisting of structural channels or angles which are supported at intervals of 10 feet or less.
  4. Provide a minimum of two pipe supports for each pipe run.
- D. Thrust anchors and guides:
1. Provide thrust anchors and guides to resist thrust due to changes in pipe sizes or direction, or dead end of pipes.

### 3.5 PIPE RESTRAINING SYSTEMS FOR UNDERGROUND PRESSURE PIPING

- A. General:
1. Provide protection from movement of pressure piping, plugs, caps, tees, valves, hydrants, and bends of 11-1/4 degrees or greater.
  2. Provide concrete thrust blocks at all locations noted in A.1 unless restrained joint type fittings are utilized.
  3. Where restrained joint type fittings are called for on the Drawings, but cannot be utilized, provide concrete thrust blocks.
- B. Concrete thrust blocks:
1. Provide precast or cast-in-place concrete thrust blocking with a compressive strength of 3000 psi in 28 days.
  2. Locate thrust blocking between solid ground and the fitting to be anchored.
  3. Unless otherwise shown or directed by the Engineer, place the base and thrust bearing sides of thrust blocking directly against undisturbed earth.
  4. Sides of thrust blocking not subject to thrust may be placed against forms.
  5. Place thrust blocking so the fitting joints will be accessible for repair.
  6. When conditions prevent the use of concrete thrust blocks, use tie rods or restrained joints of an approved type.
- C. Restrained type pipe and fittings:
1. Provide restraining system as outlined in Part 2 of this Section or utilize metal tie rods, clamps, and lugs to prevent pipe and appurtenances from movement.
    - a. Protect tie rods and clamps with epoxy or bituminous paint.
  2. Where utilizing restrained joint pipe system to immobilize joints or fittings, provide restrained joint pipe to distance indicated on the Drawings, or not less than a minimum of three pipe lengths on each side of the bend or fitting to be restrained.
    - a. Utilization of restrained joint pipe as a substitute to concrete thrust blocking is done at the Contractor's option at no additional cost to the Owner.
    - b. Provide both concrete thrust blocking and restrained joint pipe where noted on Drawings.

### 3.6 POLYETHYLENE WRAPPING OF DUCTILE IRON PIPE AND APPURTENANCES

- A. Comply with requirements of ANSI/AWWA C105/A21.5-99.
1. Place polyethylene sheet around the entire circumference of the pipe, tie or tape sheet securely to prevent displacement during backfilling.

2. Wrap all water mains, fittings, valves, fire hydrant leaders, fire hydrants, service lines, or other pipe where indicated on the Drawings.
  - a. Wrap copper service lines to a point 3 feet from center of water main.
  - b. Do not block fire hydrant weep hole.

### 3.7 CONDUCTIVITY APPURTENANCES

- A. Install conductivity through joints by use of conductivity wedges or copper cable and taps.
  1. Use two (2) wedges per joint for pipes 12 inches or smaller, and four (4) wedges per joint for pipe sizes larger than 12 inches.
  2. Use number of copper cable connectors per joint as recommended by the pipe manufacturer.

### 3.8 TESTING AND INSPECTING

- A. Hydrostatic tests:
  1. Where any section of a pressure piping is provided with concrete thrust blocking, do not make hydrostatic tests until at least 5 days after installation of the concrete thrust blocking, unless otherwise directed by the Engineer.
  2. Devise a method for disposal of waste water from hydrostatic tests, and for disinfection, as approved in advance by the Engineer.
- B. Testing of pressure piping:
  1. Subject the pressure piping to the following hydrostatic pressure:
    - a. Water, sewage, and sludge piping with a normal operating pressure of 20 psig or greater: 125 psig.
    - b. Water, sewage, and sludge piping with a normal operating pressure of less than 20 psig: 50 psig.
    - c. Water, sewage, and sludge pump suction piping: Negative pressure of 7 psig.
    - d. Air and gas piping: Pneumatic pressure of 15 psig.
  2. Hold the test pressure for a duration of 30 minutes without pressure loss or further pressure application.
  3. Replace or remake joints showing visible leakage.
  4. Remove cracked pipe, defective pipe, and cracked or defective joints, fittings, and valves. Replace with sound material and repeat the test until results are satisfactory.
  5. Make repair and replacement without additional cost to the Owner.
  6. Do not test against existing valves.

### 3.9 WATER SYSTEM DISINFECTION

- A. General:
  1. After the potable water system has been satisfactorily completed and tested, disinfect the work in accordance with AWWA C651, and "Standard Specifications for Sewer and Water and in Wisconsin".

- B. Forms of applied chlorine:
1. Apply chlorine by the dry gas feeder unless solution feed chlorination, solution of chlorine-bearing compounds, or tablet method are approved by the Owner.
    - a. Provide effective diffusion of the gas into the water within the water main and regulating the rate of gas flow.
    - b. Provide means for preventing the backflow of water into the chlorinator.
  2. Chlorine-bearing compounds in water:
    - a. Apply solution of calcium hypochlorite granular or sodium hypochlorite into one end of the section of main to be disinfected while filling the main with water.
  3. Tablet method:
    - a. Apply tablet of calcium hypochlorite to short extensions only.
    - b. Utilize only when scrupulous cleanliness has been used in construction.
    - c. Do not use if trench water or foreign material has entered the water piping or if the water is below 41 degrees F. Place tablets at the top of the main and attach by an adhesive, such as Permatex No. 1.
    - d. Place crushed tablets inside the annular space of the pipe joints.
- C. Requirement of chlorine:
1. Apply disinfecting solutions having at least 50 mg/l of available chlorine.
  2. Retain the disinfecting solutions in the work for at least 24 hours.
  3. Chlorine residual after the retention period: At least 25 mg/l.
- D. Flushing and testing:
1. Following chlorination, flush treated water thoroughly from the water system until the chlorine concentration in the water flowing from the system is no higher than generally prevailing in the Owner's system, or less than 1 mg/l.
  2. After flushing, collect two water samples on successive days at least 24 hours apart in sterile bottles treated with sodium thiosulfate. Notify the Engineer and the Owner to witness sample collection.
  3. The Owner will deliver the samples to a state approved laboratory for bacteriological analysis.
  4. Should the initial disinfection result in an unsatisfactory bacterial test, repeat the chlorination procedure until satisfactory results are obtained.
  5. The Owner will provide the water for flushing and testing.
- E. Swabbing:
1. Flush and swab the piping, valves, and fittings that must be placed in service immediately and cannot be disinfected by the above specified methods, with five percent solution of calcium hypochlorite prior to assembly.
    - a. Secure the Engineer's approval before applying this method of disinfection.



3.10 DECHLORINATION

- A. Comply with AWWA C651-05 requirements to neutralize the residual chlorine in new water mains.
- B. After new water mains have passed disinfection requirements, utilize portable diffusing dechlorinators that utilize sulfur dioxide or other chemicals listed in Appendix C of AWWA C651 to lower chlorine residuals prior to discharge to the drainage system.
  - 1. Lower concentration to 1 mg/l or less.

END OF SECTION

## SECTION 22 19 23

### VALVES

#### PART 1 - GENERAL

##### 1.1 SUMMARY

- A. Provide valves as shown on the Drawings, as specified herein, and as needed for a complete and proper installation.
- B. Related work:
  - 1. Documents affecting work under this Section include, but are not necessarily limited to, General Conditions, Supplementary Conditions, and Division 01 – General Requirements of these Specifications.
  - 2. Valves furnished as part of factory-fabricated equipment are specified as part of equipment assembly in other sections.
- C. References:
  - 1. Reserved.

##### 1.2 SUBMITTALS

- A. Shop Drawing Submittals:
  - 1. General dimensions, construction details, and manufacturer's specifications.
- B. Operation and Maintenance Manuals – Submit operation and maintenance manuals in compliance with pertinent provisions of Section 01 78 26.
- C. Certificates and Guarantees – None Required.
- D. Lubricants – None Required.
- E. Spare Parts – None Required.

##### 1.3 QUALITY ASSURANCE

- A. Provide valves of same type by same manufacturer to greatest extent possible.
- B. Provide valves with manufacturer's name and pressure rating clearly marked on valve body.
- C. Valves used in potable water shall be certified to NSF/ANSI 61 Drinking Water System - Health Effects, and certified to be Lead-Free in accordance with NSF/ANSI 372.

### VALVES

22 19 23-1 (140218.40)

- D. Brass that will come in contact with potable water shall contain no more than 0.25% lead.
- E. Brass fittings shall be marked with industry standard marking to indicate the amount of lead (no lead, low lead, etc.) in the brass.

#### 1.4 DELIVERY, STORAGE, AND HANDLING

- A. Comply with pertinent provisions of Section 01 66 11.

#### 1.5 SITE CONDITIONS – Reserved.

#### 1.6 MAINTENANCE – Reserved.

### PART 2 - PRODUCTS

#### 2.1 GATE VALVES

- A. Gate valves smaller than 3-inch size:
  - 1. Provide bronze body, wedge disc, screwed bonnet, non-rising stem, threaded-end type with handwheel.
  - 2. Valves designed for 300-pound non-shock W.O.G.
- B. Open all gate valves by turning in counterclockwise direction.

#### 2.2 BALL VALVES

- A. Brass ball valves:
  - 1. Provide 2-inch and smaller, 2-way, ball valves for use with 2-inch and smaller tube and piping systems.
    - a. Body: Brass.
    - b. Ball stem, packing washers, seat retainers, and ball retainers: Brass.
    - c. Port adapters, packing nut: Brass.
    - d. Handle: Nylon.
    - e. Ball seat: Teflon.
    - f. Adapter and retainer seals: Teflon.

#### 2.3 GLOBE VALVES

- A. Globe valves smaller than 3-inch size:
  - 1. Provide bronze body, composition disc, screwed-end type designed for 300-pound non-shock W.O.G.
- B. Acceptable manufacturers:
  - 1. Crane.
  - 2. Jenkins.

3. Stockham.
4. Lunkenheimer.
5. Or equal.

## 2.4 BUTTERFLY VALVES

### A. General:

1. Provide resilient seated type designed for a minimum water working pressure of 150 psi and a maximum temperature rating of 180 degrees F.
2. Design to meet or exceed AWWA C504 for pressure Class 150B.
3. Valve body of one piece cast iron.
4. Valve shafts of 18-8 Type 304 stainless steel and one-piece design.
5. Valve discs of Ni-Resist cast iron alloy, or ductile iron, or ASTM A48, Class 40 cast iron attached to the shaft with solid stainless steel pins or equal, to prevent slippage or misalignment.
6. Valve shaft seals designed for the use of split-V type packing, for O-ring seals or for a pull-down packing.
  - a. Design seals to be replaceable without dismantling the valve.
7. Corrosion resistant, self-lubricating valve shaft bearings.
8. Rubber valve seats designed to provide tight shutoff with 150 psi upstream pressure and zero psi downstream pressure.
9. Valves to open in counterclockwise direction.

### B. Butterfly valves installed in non-submerged flanged piping:

1. ANSI Class 125 standard flanged or wafer, where shown on Drawings.
2. Manual operation with enclosed mechanical type actuator for operation with maximum of 40 pounds of force for valves 10-inch size and smaller and 50 pounds of force for valves 12-inch size or larger. Provide 2-inch square nut for all BFVs located beneath trench grating, as shown on drawings, and hand wheel operation for all other valves accessible above trench or not covered by trench grating.
  - a. Rotate gear operator as required to prevent oil leakage and orient for accessibility.

### C. Provide fully enclosed manual operators for submerged or underground valves, gasketed, grease lubricated, and sealed for the life of the valve.

1. Stainless steel exposed nuts, bolts, springs, and washers.

### D. Acceptable manufacturers:

1. DeZurik.
2. Pratt.
3. Val-Matic Valve.
4. Or equal.

## 2.5 CHECK VALVES

- A. Swing Flex check valves 3-inch and larger:
  - 1. Provide globe style with flanges conforming to ANSI Class 125, having the following features.
    - a. Ductile iron body, Buna-N flapper, exterior and interior epoxy or fusion bonded epoxy coating.
    - b. Nema 4 Disc position indicator to indicate open/closed, 120 volt power supply and signal back to SCADA.
    - c. All internal (wetted) parts suitable for continuous operation in potable drinking water containing 5 ppm of free chlorine.
- B. Acceptable manufacturers:
  - 1. Swing Check Valves:
    - a. APCO, Rubber Flapper Valve, Series 100.
    - b. Val-Matic Swing Flex, Series 500
    - c. Or equal.

## 2.6 PVC VALVES

- A. General:
  - 1. Manufacture PVC valves of Type 1, Grade 1 polyvinyl chloride thermoplastic conforming to the latest revised specification requirements of ASTM D1784.
  - 2. Provide socket type, threaded type, or ANSI Class 150 standard flange type valve ends.
- B. Ball valves:
  - 1. True union design with two-way blocking capability.
  - 2. One-piece capsule feature, or threaded in seal carrier, or other positive means to prevent over-tightening seating components.
  - 3. Teflon seat and Viton O-ring seals.
- C. Check valves:
  - 1. True union design ball check valves.
  - 2. Viton seat and O-ring seals.
- D. Acceptable manufacturers:
  - 1. Asahi/America.
  - 2. Hayward Manufacturing Co., Inc.
  - 3. Nibco.
  - 4. Or equal.

## 2.7 HOSE VALVES

- A. Provide compression type valves with brass or bronze body, bonnet, stem and disc holder, rubber composition disc, removable wheel or tee handle, and 3/4-inch standard garden hose thread outlet connection.
  - 1. 3/8-inch steel or brass operating rod and black steel or copper tube casing on frost-proof valves.

2. Equip each hose valve with a vacuum breaker similar to Watts No. 8A, or equal.

## 2.8 SAMPLING FAUCETS

- A. Provide two smooth nose sampling faucets consisting of ¼-inch diameter copper pipe of 4-inch length (downturned 90 degrees) suitable for bacteriological sampling and flaming connected to a ½-inch pipe inlet connection with isolation valve and levered handle. Terminate over a 4-inch PVC pipe funnel drain.

## 2.9 VALVE ACCESSORIES

- A. Cut holes in trench grating for new butterfly valves installed below galvanized grating with full circle steel reinforcing sleeves at least 6 inches in diameter and 4 inches in total height, centered over valve operating nut.
- B. Provide two valve operating tee wrenches with 2-inch square socket, 1¼-inch pipe handle and 88-inch long 1½-inch pipe stem.

## 2.10 RESERVOIR ALTITUDE VALVE (RES-AV)

- A. Provide a single-seated, hydraulically-operated, diaphragm-actuated reduced port globe style valve with pilot and solenoid controls designed to refill a reservoir without overflowing it while maintaining a minimum constant upstream pressure.
  1. Valve body; Cast or ductile iron body with stainless steel trim and ANSI B16.1, Class 125, end flanges.
  2. Valve disc: Buna-N synthetic rubber compound.
    - a. Rectangular cross-section.
    - b. Retained on three and one-half sides.
  3. Disc guide: Contoured-type for smooth transition of flow.
  4. Diaphragm assembly:
    - a. Diaphragm: Flexible Buna-N synthetic rubber compound, reinforced and fully-supported.
    - b. Equip with two-piece stainless steel stem of sufficient diameter to withstand hydraulic pressure.
    - c. Drill and tap stem in cover end for accessory attachment.
    - d. Stem assembly: Fully supported in three locations with a bearing in the valve cover, a bearing in the power unit body, and an integral bearing in the valve seat.
  5. Valve Seat: Removable insert type.
  6. Fusion bonded epoxy interior.
- B. Provide pilot control system consisting of:
  1. A direct-acting, adjustable, spring-loaded, altitude pilot valve for maintaining downstream level control.
    - a. Adjustable over a range of 40 to 48.75 feet above valve centerline.

## VALVES

22 19 23-5 (140218.40)

2. A direct acting, adjustable, spring-loaded, diaphragm valve for pressure sustaining control feature upstream of the valve to prevent overdrawing system supply.
  - a. Adjustable over a range of 21.5 to 35 psi above valve centerline.
3. A "Y" strainer and needle valve as a single unit, having a fine mesh monel screen, and installed in a sturdy bronze housing.
  - a. Needle valves: Stainless steel; adjustable to regulate closing and opening speed of main valve.
4. A 120 volt solenoid valve to not allow or inactivate/cease refill operations if any booster pump is operating or called into service.
5. Equip with a dual limit switches on valve position indicator with status back to SCADA.
6. Provide pilot isolation cocks and check valves as necessary.
7. Pilot materials: Bronze with stainless steel trim pilot controls, copper tubing with brass fittings.
8. Re-use and plumb in existing reservoir sensing line.
9. Provide for dry drain capabilities.

C. Acceptable manufacturers:

1. Cla-Val Model 610 Series.
2. Or equal.

2.11 HIGH ZONE/LOW ZONE TRANSFER - PRESSURE REDUCING AND PRESSURE SUSTAINING VALVE (TRANS-PRV)

- A. Provide a single-seated, hydraulically-operated, diaphragm-actuated, angle styled valve with pilot controls designed to allow water to flow into the low pressure zone at a set downstream pressure regardless of fluctuating demand (pressure reducing) and sustain the upstream pressure to a pre-determined minimum (pressure sustaining), with solenoid override provisions.
1. Valve body: Cast or ductile iron, with bronze trim.
    - a. End flanges: ANSI B16.1, Class 125.
    - b. Cover: Cast iron, ASTM A48.
  2. Valve disc: Buna-N synthetic rubber compound.
    - a. Rectangular cross-section.
    - b. Retained on three and one-half sides.
    - c. Forms a tight seal against a single removable seat insert.
  3. Disc guide: Contoured-type for smooth transition of flow.
  4. Diaphragm assembly:
    - a. Diaphragm: Flexible Buna-N synthetic rubber compound, reinforced and fully-supported.
    - b. Equip with two-piece stainless steel stem of sufficient diameter to withstand hydraulic pressure.
    - c. Drill and tap stem in cover end for accessory attachment.
    - d. Stem assembly: fully supported in three locations with a bearing in the valve cover, a bearing in the power unit body, and an integral bearing in the valve seat.
  5. Valve seat: removable insert type.

- B. Provide the valve with pilot control system consisting of:
  - 1. A direct acting, adjustable, spring-loaded, diaphragm valve for pressure reducing control downstream of the valve.
    - a. Adjustable over a range of 25 to 65 psi over the valve inlet centerline.
  - 2. A direct acting, adjustable, spring-loaded, diaphragm valve for pressure sustaining outlet control upstream of the valve.
    - a. Adjustable over a range of 40 to 65 psi.
  - 3. A "Y" strainer and needle valve as a single unit, having a fine mesh monel screen, and installed in a sturdy bronze housing.
    - a. Needle valves: Stainless steel; adjustable to regulate closing and opening speed of main valve.
  - 4. A 120 volt solenoid valve to not allow or inactivate/cease transfer operations if either booster pump No. 3 or 4 is operating or called into service.
  - 5. Equip with a dual limit switches on valve position indicator with status back to SCADA.
  - 6. Pilot isolation cocks.
  - 7. Pilot material: Bronze with stainless steel trim for pilot controls, copper tubing and brass fittings.
  - 8. Provide for dry drain capabilities.
- C. Acceptable manufacturers:
  - 1. Cla-Val Model 92-01.
  - 2. Or equal.

## 2.12 AIR RELEASE VALVES

- A. Provide cast iron body and cover, stainless steel float, Buna-N seat, and 1/2-inch threaded inlet.
- B. Acceptable products:
  - 1. APCO Model 55.
  - 2. Val-Matic Model 22.
  - 3. Or equal.

## 2.13 PAINTING

- A. Comply with the pertinent provisions of Section 09 90 00.

## PART 3 - EXECUTION

- 3.1 Install valves in accordance with manufacturer's recommendations.
- 3.2 Locate sampling tap over raised funnel drain line.



(05/13)

- 3.3 Route air release discharge piping to drain and terminate 24 inches above drain, insert tee 26 inches above top of trench and provide 2-inch downturned air break pipe. Provide 24 mesh stainless screen over ends of open pipes.

END OF SECTION

VALVES  
22 19 23-8 (140218.40)

SECTION 22 19 26

GAUGES

PART 1 - GENERAL

1.1 SUMMARY

- A. Provide gauges as shown on the Drawings, as specified herein, and as needed for a complete and proper installation.
- B. Related work:
  - 1. Documents affecting work of this Section include, but are not necessarily limited to, General Conditions, Supplementary Conditions, and Division 01 - General Requirements of these Specifications.
  - 2. Gauges furnished as part of factory fabricated equipment are specified as part of equipment assembly in other sections.
  - 3. Refer to Division 22 piping systems sections for specific gauge applications.
- C. References:
  - 1. Reserved.

1.2 SUBMITTALS

- A. Shop Drawing Submittals:
  - 1. General dimensions and manufacturer's specifications.
- B. Operation and Maintenance Manuals – None Required.
- C. Certificates and Guarantees – None Required.
- D. Lubricants – None Required.
- E. Spare Parts – None Required.

1.3 QUALITY ASSURANCE – Reserved.

1.4 DELIVERY, STORAGE, AND HANDLING

- A. Comply with pertinent provisions of Section 01 66 11.

1.5 SITE CONDITIONS – Reserved.

1.6 MAINTENANCE – Reserved.

## PART 2 - PRODUCTS

### 2.1 GENERAL

- A. Provide gauges with ranges shown on the Drawings or specified under Division 22 piping systems.

### 2.2 BOURDON TUBE TYPE PRESSURE GAUGES

- A. Provide phosphor bronze tube, brass socket, 4½-inch aluminum alloy case, white dial, and plastic glass lens.
  - 1. Provide 1/4-inch gauge cock and stainless steel cartridge snubber.
- B. Schedule:
  - 1. Two; 0 to 60 psi for suction side of Booster Pumps 3 and 4.
  - 2. Two; 0 to 150 (or 160) psi for discharge side of Booster Pumps 3 and 4.
  - 3. One; 0 to 15 psi for Pressure Transducer for reservoir level.
  - 4. One; 0 to 60 psi for Pressure Transducer for Low Pressure Zone.
  - 5. One; 0 to 150 (or 160) psi for Pressure Transducer for High Pressure Zone.
- C. Provide ACCO Helicoid Type 410, H.O. Trerice Company 500X, or equal.

### 2.3 INSTRUMENT PROTECTORS

- A. Provide instrument protectors for gauges where shown on the Drawings.
  - 1. Provide wafer ring type instrument protectors with carbon steel rings, Buna-N flexible cylinder and silicone oil sensing fluid.
    - a. Design to fit between ANSI Class 125 standard flanges of size shown on the Drawings.
  - 2. Provide Ronningen-Petter Iso-Ring, or Red Valve Company Series 48 Pressure Sensor, or equal.

## PART 3 - EXECUTION

- 3.1 Install gauges and accessories in accordance with manufacturer's recommendations.

END OF SECTION

SECTION 22 19 33

PIPE INSULATION

PART 1 - GENERAL

1.1 SUMMARY

- A. Provide pipe insulation as shown on the Drawings, as specified herein, and as needed for a complete and proper installation.
- B. Related work:
  - 1. Documents affecting work under this Section include, but are not necessarily limited to, General Conditions, Supplementary Conditions, and Division 01 - General Requirements of these Specifications.

1.2 SUBMITTALS

- A. Shop Drawing Submittals:
  - 1. Manufacturer's specifications and other data needed to assure compliance with specified requirements.
  - 2. Manufacturers' recommended installation procedures.
- B. Operation and Maintenance Manuals – None Required.
- C. Certificates and Guarantees – None Required.
- D. Lubricants – None Required.
- E. Spare Parts – None Required.
- F. Comply with pertinent provisions of Section 01 33 01.

1.3 QUALITY ASSURANCE – Reserved.

1.4 DELIVERY, STORAGE, AND HANDLING

- A. Comply with pertinent provisions of Section 01 66 11.

1.5 SITE CONDITIONS – Reserved.

1.6 MAINTENANCE – Reserved.

PART 2 - PRODUCTS

2.1 PIPE INSULATION

- A. Provide pipe insulation with the following features:
  - 1. Flame-attenuated fiberglass bonded with thermosetting resin.

2. Service temperature: 850 degrees F maximum.
  3. All-service vapor barrier jacket.
    - a. Reinforced white kraft bonded to aluminum foil.
    - b. Factory-applied double pressure-sensitive adhesive system with matching pressure-sensitive butt strips.
  4. Minimum thickness:
    - a. Pipe sizes 2-inch and smaller: 1-inch.
- B. Provide saddle spreaders between jacketed pipe insulation and pipe supports.
- C. Acceptable products:
1. Manville Micro-Lok.
  2. Owens-Corning Fiberglass ASJ-SSL-II.
  3. Or equal.

## 2.2 EXHAUST PIPE INSULATION

- A. Provide exhaust pipe insulation with the following features:
1. Molded high temperature hydrous calcium silicate.
    - a. Thickness: 4 inches minimum.
    - b. Temperature range: to 1,200 degrees F.
  2. Jacketing: 0.016-inch stucco pattern aluminum with stainless steel bands.
    - a. For flanges and fittings: Glass fabric covered with weatherproof mastic finish.
- B. Acceptable products:
1. Manville Thermo-12.
  2. Owens-Corning Kaylo.
  3. Or equal.

## PART 3 - EXECUTION

### 3.1 INSTALLATION

- A. Install over clean, dry surfaces and in strict accordance with the manufacturer's recommended installation procedures.
- B. Exhaust pipe:
1. Except expansion pieces, apply insulation to exhaust piping, including silencer and all flanges and fittings, to the specified thickness.
  2. Wire first layer of insulation in place. Apply second layer with joints staggered.

END OF SECTION

SECTION 22 19 43

PLUMBING AND FIXTURES

PART 1 - GENERAL

1.1 SUMMARY

- A. Provide plumbing as shown on the Drawings, as specified herein, and as needed for a complete and proper installation including, but not necessarily limited to:
  - 1. Building cold water piping systems.
  - 2. Drain, waste, and vent systems.
- B. Related work:
  - 1. Documents affecting work of this Section include, but are not necessarily limited to, General Conditions, Supplementary Conditions, and Division 01 - General Requirements of these Specifications.
- C. References:
  - 1. Reserved.

1.2 SUBMITTALS

- A. Shop Drawing Submittals:
  - 1. Manufacturer's specification catalog cuts for water heaters.
- B. Operation and Maintenance Manuals: Submit operation and maintenance manuals in compliance with pertinent provisions of Section 01 78 26 for water heaters.
- C. Certificates and Guarantees – None Required.
- D. Lubricants – None Required.
- E. Spare Parts – None Required.
- F. Comply with pertinent provisions of Section 01 33 01.

1.3 QUALITY ASSURANCE

- A. Use adequate numbers of skilled workmen who are thoroughly trained and experienced in the necessary crafts and who are completely familiar with the specified requirements and the methods needed for proper performance of the work of this Section.

- B. Codes and regulations:
  - 1. In addition to complying with the specified requirements, comply with pertinent regulations of governmental agencies having jurisdiction.
  - 2. In the event of conflict between or among specified requirements and pertinent regulations, the more stringent requirement will govern when so directed by the Engineer.

#### 1.4 DELIVERY, STORAGE, AND HANDLING

- A. Comply with pertinent provisions of Section 01 66 11.

#### 1.5 SITE CONDITIONS – Reserved.

#### 1.6 MAINTENANCE – Reserved.

### PART 2 - PRODUCTS

#### 2.1 PIPE SCHEDULE

- A. Drain, waste, and vent system:
  - 1. For inside building:
    - a. Provide plastic drainage pipe and fittings unless otherwise shown on the Drawings.
- B. Potable water system (cold water piping): as shown on the Drawings.
  - 1. Inside building:
    - a. Cold water piping: Use copper pipe, except for chlorine analyzer piping which can be plastic. Provide insulation for building water supply piping.
- C. Indirect drains (gland drain, etc.):
  - 1. Provide Schedule 40 black steel pipe with malleable iron screwed fittings; except provide galvanized where pipe or fittings are exposed to the weather.
  - 2. Size lines to match equipment connections.

#### 2.2 PIPE AND FITTING MATERIALS

- A. Comply with Section 22 19 13.

#### 2.3 VALVES

- A. Comply with Section 22 19 23.

## PART 3 - EXECUTION

### 3.1 SURFACE CONDITIONS

- A. Examine the areas and conditions under which work of this Section will be performed. Correct conditions detrimental to timely and proper completion of the Work. Do not proceed until unsatisfactory conditions are corrected.

### 3.2 PLUMBING SYSTEM LAYOUT

- A. Lay out the plumbing system in careful coordination with the Drawings, determining proper elevations for all components of the system and using only the minimum number of bends to produce a satisfactorily functioning system.
- B. Follow the general layout shown on the Drawings in all cases except where other work may interfere.
- C. Lay out pipes to fall within partition, wall, or roof cavities, and to not require furring other than as shown on the Drawings.

### 3.3 INSTALLATION OF PIPING AND EQUIPMENT

- A. General:
  - 1. Comply with Section 22 19 13 for pipe installation, support, testing, and/or disinfection.
  - 2. Thoroughly clean items before installation. Cap pipe openings to exclude dirt until fixtures are installed and final connections have been made.
  - 3. Run horizontal sanitary and storm drainage piping at a uniform grade of 1/4-inch per foot, unless otherwise noted. Run horizontal water piping with an adequate pitch upwards in direction of flow to allow complete drainage.
  - 4. Pipe the drains from pump glands, drip pans, relief valves, air vents, and similar locations, to spill over an open sight drain, floor drain, or other acceptable discharge point, and terminate with a plain end unthreaded pipe 6 inches above the drain.
  - 5. Securely bolt all equipment, isolators, hangers, and similar items in place.
  - 6. Support each item independently from other pipes. Do not use wire for hanging or strapping pipes.
  - 7. Provide complete dielectric isolation between ferrous and non-ferrous metals.
  - 8. Provide union and shut off valves suitably located to facilitate maintenance and removal of equipment and apparatus.
  - 9. Install 1/4-inch bronze cock with 1/4-inch copper tubing return manual air vents at the high points of all pipelines carrying water of any service class which cannot be vented through service connections or vent cocks provided with equipment.



- B. Equipment access:
  - 1. Install piping, equipment, and accessories to permit access for maintenance. Relocate items as necessary to provide such access, and without additional cost to the Owner.
  - 2. Provide access doors where valves, motors, or equipment requiring access for maintenance are located in walls or chases or above ceilings. Coordinate location of access doors with other trades as required.

### 3.4 VALVES

- A. Provide valves in water, air, and gas systems. Locate and arrange so as to give complete regulation of apparatus, equipment and fixtures.
- B. Provide valves in at least the following locations:
  - 1. In branches and/or headers of water piping serving a group of fixtures.
  - 2. On both sides of apparatus and equipment.
  - 3. For shutoff of risers and branch mains.
  - 4. For flushing and sterilizing the system.
  - 5. Where shown on the Drawings.
- C. Locate valves for easy accessibility and maintenance.

### 3.5 OTHER TESTING AND ADJUSTING

- A. Provide personnel and equipment, and arrange for and pay the costs of, all required tests and inspections required by governmental agencies having jurisdiction.
- B. Where tests show materials or workmanship to be deficient, replace or repair as necessary, and repeat the tests until the specified standards are achieved.
- C. Adjust the system to optimum standards of operation.

END OF SECTION

SECTION 26 05 19

LOW-VOLTAGE ELECTRICAL POWER CONDUCTORS AND CABLES

PART 1 - GENERAL

1.1 SUMMARY

- A. Provide low-voltage electrical power conductors and cables as shown on the Drawings, as specified herein, and as needed for a complete and proper installation.
- B. Related work:
  - 1. Documents affecting work under this Section include, but are not necessarily limited to, General Conditions, Supplementary Conditions, and Division 01 - General Requirements of these Specifications.
- C. References:
  - 1. Reserved.

1.2 SUBMITTALS

- A. Shop Drawing Submittals – None Required.
- B. Operation and Maintenance Manuals – None Required.
- C. Certificates and Guarantees – None Required.
- D. Spare Parts – None Required.

1.3 QUALITY ASSURANCE

- A. Comply with the following requirements:
  - 1. NFPA 70 National Electrical Code (NEC).
  - 2. Local codes and ordinances.

1.4 DELIVERY, STORAGE, AND HANDLING

- A. Comply with pertinent provisions of Section 01 66 11.

1.5 SITE CONDITIONS – Reserved.

1.6 MAINTENANCE – Reserved.

## PART 2 - PRODUCTS

### 2.1 GENERAL

- A. Comply with the following standards:
  - 1. UL 83 and ICEA S-61-402 for thermoplastic insulated wire and cable.
  - 2. UL 44, ICEA S-19-81 and ICEA S-66-524 for rubber or rubber-like and cross-linked thermosetting polyethylene insulated wire and cable.
- B. Provide copper wire only.
- C. No underground splices allowed unless approved by the Engineer.

### 2.2 WIRE AND CABLE IN RACEWAY

- A. Power, light, and control conductors:
  - 1. Insulation: Rated for 600 volts.
    - a. Use dual rated type THHN/THWN in temperature controlled indoor locations.
    - b. Use Type XHHW in underground locations and unheated concrete structures.
  - 2. Use stranded wire for control conductors.
- B. Variable Frequency Drive (VFD) Multi-conductor cable:
  - 1. Conductor: 3C-7 strand copper conductors to ASTM B8.
  - 2. Insulation: 600V, flame retardant, cross-linked polyethylene (FR XLPE), 90 degrees C, wet/dry (UL44) XHHW-2.
  - 3. Grounding conductors: 3 stranded bare copper grounds symmetrically located in continuous contact with a copper tape shield.
  - 4. Shielding: Dual copper tape shields helically wound with 50% overlap.
  - 5. Assembly: 3 phase conductors with symmetrically located tri-sectional grounding conductors in continuous contact with a copper tape shield.
  - 6. Overall jacket: 90C-25C flame retardant yellow PVC LAG (Low Acid Gas) sunlight resistant.
  - 7. Temperature: 90 degree C wet/dry.
  - 8. Voltage class: 600 volts.
  - 9. Approvals: IEEE 383, 70,000 BTU flame test; UL 1277 and UL 1581; tray cable rated (TC).
  - 10. Manufacturer:
    - a. Anixter-Shawflex VFD Cable.
    - b. Belden VFD Cable.
    - c. Or equal.

### 2.3 JOINTS, TAPS, SPLICES, AND TERMINATIONS

- A. Conductors No. 10 AWG and smaller: Use twist type insulated wire nut solderless connectors.

- B. Conductors No. 8 AWG and larger: Use solderless compression type connectors of type that will not loosen under vibration or normal strains.
- C. Control and instrumentation conductors: Use crimp type spade connectors where control wires are connected to screw terminals of equipment.
- D. Joints, taps, and splices located in enclosures subject to moisture: Use watertight splice kits.

#### 2.4 PERMANENT WIRE MARKERS

- A. Provide type-on, self-laminating vinyl, heat shrink polyolefin or nylon clip-sleeve, alpha-numeric, permanent wire markers.
  - 1. Use fine-line, black, permanent ink pens where field marking is necessary.
  - 2. Cloth tags are not acceptable.

### PART 3 - EXECUTION

#### 3.1 INSTALLATION

- A. Install wiring system in accordance with manufacturer's recommendations.
- B. Install wire and cable in conduit unless otherwise shown on the Drawings.
- C. Trench and backfill for direct burial cables: Comply with Section 31 23 79.
  - 1. Install cable in rigid steel conduit under and 1-foot beyond all driveways and other pavement, and within a radius of 5 feet from all structures, trees, obstacles, etc.
  - 2. Provide suitable bracing for cable to withstand movement due to settlement where cable crosses a previous or new excavation.
  - 3. Seal all conduit entrances with watertight cable-conduit seals to prevent entrance of water into underground structures and caulk opposite end of conduit where conductors enter junction box, panel or electrical enclosure.
- D. Install warning tape along and above direct buried cable.
  - 1. Use red plastic, 6-inch wide tape.
  - 2. Imprinted "CAUTION - ELECTRIC CABLE BELOW".
  - 3. Bury approximately 1-foot below surface before final backfilling.
- E. Maintain barrier or conduit separation between power conductors and instrumentation conductors to avoid magnetic interaction where such conductors enter and pass through same manhole, handhole, casing pipe, box, or enclosure.

#### 3.2 WIRE AND CABLE IDENTIFICATION

- A. Install permanent wire markers on wire and cable in junction boxes, pull boxes, wireways, and wiring gutters of panels. Markers to identify wire or cable number.

(04/12)

- B. Provide schedule identifying various power and lighting conductors from power source to equipment or device served.

### 3.3 FIXTURE OUTLETS

- A. Use minimum AWG No. 12 wire for conductors supplying power to single fixture.

END OF SECTION

## SECTION 26 05 23

## CONTROL-VOLTAGE ELECTRICAL POWER CABLES

## PART 1 - GENERAL

## 1.1 SUMMARY

- A. Provide control-voltage wires, cables, and connectors as shown on the Drawings, as specified herein, and as needed for a complete and proper installation.
- B. Related work:
  - 1. Documents affecting work under this Section include, but are not necessarily limited to, General Conditions, Supplementary Conditions, and Division 01 - General Requirements of these Specifications.
- C. References:
  - 1. Reserved.

## 1.2 SUBMITTALS

- A. Shop Drawing Submittals – None Required.
- B. Operation and Maintenance Manuals – None Required.
- C. Certificates and Guarantees – None Required.
- D. Spare Parts – None Required.

## 1.3 QUALITY ASSURANCE

- A. Comply with the following requirements:
  - 1. NFPA 70 National Electrical Code (NEC).
  - 2. Local codes and ordinances.

## 1.4 DELIVERY, STORAGE, AND HANDLING

- A. Comply with pertinent provisions of Section 01 66 11.

## 1.5 SITE CONDITIONS – Reserved.

## 1.6 MAINTENANCE – Reserved.

## PART 2 - PRODUCTS

## 2.1 GENERAL

- A. Comply with the following standards:
  - 1. UL 83 and ICEA S-61-402 for thermoplastic insulated wire and cable.

2. UL 44, ICEA S-19-81 and ICEA S-66-524 for rubber or rubber-like and cross-linked thermosetting polyethylene insulated wire and cable.

B. Provide copper wire only.

## 2.2 WIRE AND CABLE

A. Shielded instrumentation cable:

1. Conductors: Stranded No. 18 AWG tinned copper.
2. Insulation: Polyethylene or fluorinated ethylene propylene (FEP), color coded, rated for 300 volts.
3. Jacket: Polyvinyl chloride or FEP.
4. Shielding: Aluminum polyester, 100 percent coverage.
  - a. Includes stranded No. 20 AWG tinned copper drain wire.
5. Provide Belden, or equal, copper instrumentation cable systems:
  - a. For 2-conductor requirements:
    - (1) Belden No. 8760 suitable for indoor.
    - (2) Belden No. 88760 suitable for outdoor & burial.
  - b. For 3-conductor requirements:
    - (1) Belden No. 8770 suitable for indoor.
    - (2) Belden No. 88770 suitable for outdoor & burial.
  - c. For 2-twisted pair requirements: Belden No. 9552.
6. UL Listed for use.
7. Provide shielded instrumentation cable suitable for flooded burial and freeze/thaw conditions where installed in duct banks, underground conduits, or conduits in and on unheated structures.

B. Multi-conductor shielded instrumentation cable:

1. Conductors: Stranded No. 16 or 18 AWG tinned copper.
2. Insulation: Flame-retardant ethylene propylene rubber (EPR) Type II or cross-linked polyethylene (XLPE). Color code per ICEA Method 1; pair – black & white. One conductor in each pair is printed alpha-numerically for easy identification.
3. Shield: Individual pairs shielded with aluminum/polyester in contact with stranded tinned copper drain wire and overall shielded is aluminum/polyester in contact with stranded tinned copper drain wire.
4. Outer jacket: Flame-retardant thermoplastic chlorinated polyethylene (CPE).
5. Volts: 300V or 600V.
6. Conductors: Class B stranding per ASTM B8, tinned annealed copper per ASTM B33.
7. Application: In free air, raceways or direct burial in accordance with NEC. Permitted for use in Class I Div. 2 industrial hazardous locations per NEC Article 501-4(b) for UL Type PLTC cables.
8. Acceptable manufacturers:
  - a. General Cable.
  - b. Omni Cable.
  - c. Or equal.

- C. Data cables:
1. Verify unique cable requirements of individual data systems shown on Drawings with Systems Integrator.
  2. Provide Belden or equal, copper data cable systems:
    - a. DeviceNet Applications:
      - (1) No. 3083A CPE (Thick).
      - (2) No. 3085A CPE (Thin).
      - (3) No. 3082A PVC (Thick).
      - (4) No. 3084A PVC (Thin).
    - b. ControlNet Applications:
      - (1) No. 3092A RG-6 PVC Quad shield coax suitable for outdoor.
      - (2) No. 3093A RG-6 FEP Quad shield coax, plenum, suitable for outdoor & burial.
    - c. E/IP application:
      - (1) Belden No. 7953A Cat 6 – 4 pair, bonded, indoor rated, stranded, shielded, 600 Volt rated.
      - (2) Belden No. 7937A Cat 5e – 4 pair, bonded, burial rated, stranded, shielded, 300 Volt rated.
    - d. Profibus DP Applications:
      - (1) No. 3079A 22AWG 300V Twinax.
      - (2) No. 3079E 22AWG 300V Twinax, Flex Version.
    - e. Modbus application:
      - (1) No. 8777 22 AWG, 3 pair modem drop cable.
  3. Provide data cable suitable for flooded burial and freeze/thaw conditions where installed in duct banks, underground conduits, or conduits in and on unheated structures.
  4. Provide data cables UL listed for intended use.
  5. Crimped-on "male" connectors are not allowed for E/IP cable terminations. E/IP cables are to be "punched-down" in "key-stone" type jack that is to be supplied by panel manufacturer as specified in other cabinet/panel specifications.
  6. Utilize 600 Volt rated cable inside electrical enclosures that contain more than 300 Volts.

### 2.3 JOINTS, TAPS, SPLICES, AND TERMINATIONS

- A. Conductors No. 10 AWG and smaller: Use twist type insulated wire nut solderless connectors.
- B. Control and instrumentation conductors: Use crimp type spade connectors where control wires are connected to screw terminals of equipment.
- C. Joints, taps, and splices located in enclosures subject to moisture: Use watertight splice kits.

### 2.4 PERMANENT WIRE MARKERS

- A. Provide type-on, self-laminating vinyl, heat shrink polyolefin or nylon clip-sleeve, alpha-numeric, permanent wire markers.
  1. Use fine-line, black, permanent ink pens where field marking is necessary.



2. Cloth tags are not acceptable.

### PART 3 - EXECUTION

#### 3.1 INSTALLATION

- A. Install wiring system in accordance with manufacturer's recommendations.
- B. Install wire and cable in conduit unless otherwise shown on the Drawings.
- C. Maintain barrier or conduit separation between power conductors and instrumentation conductors to avoid magnetic interaction where such conductors enter and pass through same manhole, handhole, casing pipe, box, or enclosure.
- D. Run instrumentation conductors into control cabinets or MCC only if terminated therein. Maintain separation of power and instrumentation conductors inside cabinets.
- E. Provide individual wiring compartments or barrier for separation between intrinsically safe and non-intrinsically safe conductors inside enclosures.

#### 3.2 WIRE AND CABLE IDENTIFICATION

- A. Install permanent wire markers on wire and cable in junction boxes, pull boxes, wireways, and wiring gutters of panels. Markers to identify wire or cable number.
- B. Provide schedule identifying various control and instrumentation circuit conductors based on equipment tag numbers.

END OF SECTION

## SECTION 26 05 26

## GROUNDING AND BONDING OF ELECTRICAL SYSTEMS

## PART 1 - GENERAL

## 1.1 SUMMARY

- A. Provide grounding and bonding as shown on the Drawings, as specified herein, and as needed for a complete and proper installation.
- B. Related work:
  - 1. Documents affecting work under this Section include, but are not necessarily limited to, General Conditions, Supplementary Conditions, and Division 01 - General Requirements of these Specifications.
- C. References:
  - 1. Reserved.

## 1.2 SUBMITTALS

- A. Shop Drawing Submittals – None Required.
- B. Operation and Maintenance Manuals – None Required.
- C. Certificates and Guarantees – None Required.
- D. Spare Parts – None Required.

## 1.3 QUALITY ASSURANCE

- A. Comply with the following requirements:
  - 1. NFPA 70 National Electrical Code (NEC).
  - 2. Local codes and ordinances.
  - 3. Utility company providing electrical service.

## 1.4 DELIVERY, STORAGE, AND HANDLING

- A. Comply with pertinent provisions of Section 01 66 11.

## 1.5 SITE CONDITIONS – Reserved.

## 1.6 MAINTENANCE – Reserved.

## PART 2 - PRODUCTS

## 2.1 GENERAL

- A. Ground clamp fittings, connections, and joints:
  - 1. Provide interlocking listed clamp fabricated from high strength corrosion-resistant metal.

2. Use high strength silicon bronze U-bolt, nuts, and lock washers.
  3. Use high strength cast bronze ground rod clamp listed for direct burial for ground rod.
- B. Ground rods:
1. Provide copper or copper-clad steel core.
  2. Use 5/8-inch diameter minimum and 10-foot long.
- C. Ground wires:
1. Use copper wire only.
  2. Size as shown on the Drawings.

### PART 3 - EXECUTION

#### 3.1 INSTALLATION

- A. Grounding electrode system:
1. Attach ground wire to a point ahead of water meter or service shut-off valve, when available.
  2. Attach ground wire to building steel where available.
- B. Main and supplemental grounding electrode conductors:
1. Install jumper or shunt around water meter and/or shut-off valve when applicable.
  2. Attach nonferrous metal tag at water pipe connection to warn against removal.
- C. Install properly terminated equipment grounding conductor in all flexible conduits.
- D. Drive ground rod to a depth that allows for physical protection and concealment below finished floor or grade. Leave approximately 4 inches of rod exposed for inspection prior to concealment.
- E. Make connections to ground rods with molded exothermic weld process, or a listed and approved ground rod clamp.

#### 3.2 FIELD QUALITY CONTROL

- A. Perform and record resistance-to-earth measurements witnessed by Engineer with all grounding electrode conductors.
1. Isolate ground under test from other grounds.
  2. Measure in normally dry conditions not less than 48 hours after rainfall.
  3. Measure at each ground rod and other ground connections when applicable.
- B. Maximum D.C. resistance allowable is 5 ohms.
- C. Use the three-point method of measurement, unless specified otherwise.

END OF SECTION

SECTION 26 05 29

HANGERS AND SUPPORTS FOR ELECTRICAL SYSTEMS

PART 1 - GENERAL

1.1 SUMMARY

- A. Provide hangers and supports as shown on the Drawings, as specified herein, and as needed for a complete and proper installation.
- B. Related work:
  - 1. Documents affecting work under this Section include, but are not necessarily limited to, General Conditions, Supplementary Conditions, and Division 01 - General Requirements of these Specifications.
- C. References:
  - 1. Reserved.

1.2 SUBMITTALS

- A. Shop Drawing Submittals – None Required.
- B. Operation and Maintenance Manuals – None Required.
- C. Certificates and Guarantees – None Required.
- D. Spare Parts – None Required.

1.3 QUALITY ASSURANCE

- A. Comply with the following requirements:
  - 1. NFPA 70 National Electrical Code (NEC).
  - 2. Local codes and ordinances.

1.4 DELIVERY, STORAGE, AND HANDLING

- A. Comply with pertinent provisions of Section 01 66 11.

1.5 SITE CONDITIONS – Reserved.

1.6 MAINTENANCE – Reserved.

PART 2 - PRODUCTS

2.1 GENERAL

- A. Provide zinc galvanized, cadmium plated steel, or malleable iron supporting devices.

- B. Provide factory PVC-coated metal supports, clamps, and hardware when PVC-coated, galvanized rigid steel conduit is used.
  - 1. Comply with Section 26 05 33.
- C. Provide PVC supports, clamps and hardware for nonmetallic conduit system.
- D. Provide drilled expansion insert type sleeve anchors, lag shields, or plastic anchors suitable for load and application.

## 2.2 SUPPORTING STRUCTURES

- A. Provide rack supports of stainless steel channels with adequate feet for secure mounting.

## 2.3 MOUNTING PANELS

- A. Provide adequately braced and sized equipment mounting panels where required to mount equipment.
- B. Paint surfaces of panel to comply with Section 09 90 00.

## 2.4 CONDUIT SUPPORTS

- A. Provide continuous or T-slot concrete insert channel.
- B. Provide one-hole or two-hole conduit straps as required.

# PART 3 - EXECUTION

## 3.1 PREPARATION

- A. Determine if ceiling channel system is adequately supported to receive and support lighting fixtures.
  - 1. Where deemed inadequate, provide additional support to prevent ceiling from sagging.

## 3.2 INSTALLATION

- A. Install supporting devices in accordance with manufacturer's recommendations.
- B. Do not use perforated hanger iron.
- C. Pass conduit through pitch pocket at roof line when extending conduit through roof.

END OF SECTION

SECTION 26 05 33

RACEWAY AND BOXES FOR ELECTRICAL SYSTEMS

PART 1 - GENERAL

1.1 SUMMARY

- A. Provide raceway and boxes as shown on the Drawings, as specified herein, and as needed for a complete and proper installation.
- B. Related work:
  - 1. Documents affecting work under this Section include, but are not necessarily limited to, General Conditions, Supplementary Conditions, and Division 01 - General Requirements of these Specifications.
- C. References:
  - 1. Reserved.

1.2 SUBMITTALS

- A. Shop Drawing Submittals – None Required.
- B. Operation and Maintenance Manuals – None Required.
- C. Certificates and Guarantees – None Required.
- D. Spare Parts – None Required.

1.3 QUALITY ASSURANCE

- A. Comply with the following requirements:
  - 1. NFPA 70 National Electrical Code (NEC).
  - 2. Local codes and ordinances.

1.4 DELIVERY, STORAGE, AND HANDLING

- A. Comply with pertinent provisions of Section 01 66 11.

1.5 SITE CONDITIONS – Reserved.

1.6 MAINTENANCE – Reserved.

PART 2 - PRODUCTS

2.1 GENERAL

- A. Provide conduit system of the types of conduit as indicated in the Conduit Usage Schedule in Part 3 of this Section.

- B. Provide junction boxes as necessary to facilitate pulling and/or splicing of wires.
- C. Provide factory PVC-coated boxes of same coating thickness as conduit system where PVC-coated conduit is used (except hazardous classified areas).
- D. Provide PVC boxes where non-metallic conduit system is used.

## 2.2 METAL RACEWAY AND FITTINGS

- A. Galvanized rigid steel conduit (GRC) and fittings:
  - 1. Conduit: Comply with ANSI C80.1 and UL 6 standards.
  - 2. Fittings: Comply with UL 514B and NEMA FB1 & FB2.10 standards.
- B. Intermediate metal conduit (IMC) and fittings:
  - 1. Conduit: Comply with ANSI C80.6 and UL 1242 standards.
  - 2. Fittings: Comply with UL 514B and NEMA FB1 & FB2.10 standards.
- C. Electrical metallic tubing (EMT) and fittings:
  - 1. Conduit: Comply with ANSI C80.3 and UL 797 standards.
  - 2. Fittings: Comply with UL 514B and NEMA FB1 & FB2.10 standards.
- D. Polyvinyl-chloride (PVC) coated galvanized rigid steel conduit and fittings.
  - 1. Conduit: Comply with ANSI C80.1, UL 6, and NEMA RN1 standards.
    - a. Galvanized rigid steel conduit with full weight 40 mil thick PVC exterior coating.
    - b. PVC bonding to galvanized metal shall be stronger than plastic tensile strength.
    - c. Provide nominal 2 mil thick urethane, or equal, coating to inside of conduit.
  - 2. Fittings:
    - a. Comply with UL 514B and NEMA RM1 standards.
    - b. Threaded with full weight 40 mil thick PVC exterior coating.
    - c. Inside coating: Nominal 2 mil thick urethane, or equal.
    - d. Provide pressure sealing sleeves on all conduit openings.
  - 3. Accessories: Provide straps, clamps, and screws with full weight 40 mil thick PVC exterior coating.
  - 4. Provide factory-installed PVC coating on all components of PVC coated conduit system.
    - a. Use coating in field only for touch-up of components.
- E. Rigid aluminum conduit and fittings:
  - 1. Conduit: Comply with ANSI C80.5 and UL 6 standards.
  - 2. Fittings: Threaded, and in compliance with Comply with UL 514B and NEMA FB1 standards.

## 2.3 FLEXIBLE METAL RACEWAY AND FITTINGS

- A. Liquidtight, flexible metal conduit and fittings:
  - 1. Conduit: Comply with UL 360 standards.
    - a. Galvanized flexible steel core.

- b. Provide outer liquidtight, PVC sunlight resistant jacket.
2. Fittings: Comply with UL 514B and NEMA FB1 standards.

B. Flexible metal conduit and fittings:

1. Conduit: Comply with UL 1 standards.
2. Fittings: Comply with UL 514B and NEMA FB1 standards.

## 2.4 NON-METALLIC RACEWAY AND FITTINGS

A. Rigid conduit: Comply with ANSI C80.3, ASTM F512, NEMA TC-2 and UL 651 standards.

1. Use heavy wall, sunlight resistant, PVC Schedule 40 or 80 as shown on the Drawings.
2. Rated for use with 90 degree C. conductors.

B. Liquid tight, flexible conduit: Comply with ANSI-79 and UL 1660 standards.

1. Fittings: Liquid-tight.

C. Fittings:

1. Comply with UL 514C and NEMA TC3 standards.
2. Schedule 40 or 80 to match conduit.

## 2.5 CONDUIT BODIES

A. Metallic conduit bodies:

1. Comply with ANSI C80.4 and C33.84, and UL 514 standards.
  - a. Use galvanized or cadmium plated malleable iron, or copper-free aluminum material.
  - b. Provide factory PVC-coated conduit bodies of same coating thickness as conduit where PVC-coated conduit is used.

B. Non-metallic conduit bodies:

1. Comply with ASTM F512 and UL 514 and 651 standards.
  - a. Compatible with Schedule 40 or 80 conduit.
  - b. UL listed for use.

C. Provide removable cover with gasket and corrosion-resistant screws.

## 2.6 WALL AND FLOOR SLEEVES

- A. Comply with requirements of Section 22 19 13.

## 2.7 FLEXIBLE SEALING COMPOUND

- A. Use Panduit DS-5 duct sealing compound, or equal, where air and vaportight conduit sealing is required.



## 2.8 OUTLET BOXES AND JUNCTION BOXES

- A. Flush mounted: Provide galvanized steel boxes and accessories suitable for application and type construction.
- B. Surface mounted: Provide corrosion-resistant single or multiple gang malleable iron or aluminum Type FS or FD cast boxes with threaded hubs, or pressed steel boxes as permitted under Part 3 of this Section.
- C. Weatherproof boxes: Provide gasketed covers and corrosion-proof fasteners.

## 2.9 PULL BOXES AND SPECIAL PURPOSE OUTLET BOXES

- A. Provide pull boxes with covers held in place by corrosion-resistant machine screws, and of type or NEMA rating as shown on the Drawings.
- B. Provide special purpose outlet boxes furnished with fixtures and devices where standard outlets are not applicable.

## PART 3 - EXECUTION

### 3.1 INSTALLATION - RACEWAY

- A. Install conduit and fittings in accordance with manufacturer's recommendations.
- B. Run exposed conduits parallel to or at right angles with lines of building or structure.
- C. Route conduit runs above suspended panel ceilings so as not to interfere with panel removals.
- D. Keep conduit plugged, clean and dry during construction.
- E. Install wall sleeves as shown on the Drawings where conduits pass through foundation walls below grade.
- F. Conduit runs extending through areas of different temperature or atmospheric conditions, or partly indoors and partly outdoors must be sealed, drained, and installed in a manner preventing drainage of condensed or entrapped moisture into cabinets, boxes, fixtures, motors, or equipment enclosures.
- G. Conduits run in concrete structures:
  - 1. Comply with applicable provisions of ACI 318 for conduits embedded in structural frame slab.
  - 2. Install conduits parallel to each other spaced on center of at least three times conduit trade diameter with minimum 2-inch concrete covering.
  - 3. Conduits over 1-1/2 inches may not be installed in slab without approval of Engineer.

- H. Install bushings with ground lugs and integral plastic linings at equipment with open-bottom conduit entrances.
- I. In precast areas, run conduits in roof insulation space. Use 3/4-inch maximum conduit size.
- J. Exterior underground conduit:
  - 1. Comply with pertinent provisions of Section 31 23 79.
  - 2. Provide conduits or ducts terminating below grade with means to prevent entry of dirt or moisture.

### 3.2 INSTALLATION – BOXES

- A. Install boxes in accordance with manufacturer's recommendations.
- B. Use weatherproof boxes for interior and exterior locations exposed to weather or moisture.
- C. Do not install boxes back to back or through wall. Off set outlet boxes on opposite sides of wall minimum 12 inches.
- D. Set outlet boxes parallel to construction.
- E. Thoroughly clean boxes prior to installing wiring devices.

### 3.3 CUTTING AND PATCHING

- A. Make provisions for openings, holes, and clearances through walls, floors, ceilings, and partitions in advance of construction.
- B. Cut and patch in accordance with Section 01 73 29.
- C. Core drill through reinforced concrete with approval of Engineer.

### 3.4 RESTRICTIONS

- A. Cross high temperature piping or ducts with 12-inch clearance.
- B. Do not route conduit over boiler, incinerator, or other high temperature equipment, piping, or ducts.
- C. Do not route exposed conduit below and parallel to, or adjacent to water piping.
- D. Do not use EMT indenter-type fittings on EMT conduit.

### 3.5 EXISTING CONDUIT

- A. The Drawings show the approximate location of existing conduit as indicated by available existing records. The proposed work may require crossing, relocating, and, in some cases, connecting to the existing conduits.
- B. Expose carefully the existing conduits throughout the area of proposed work.
  - 1. All existing conduits to remain undisturbed and in uninterrupted use until such time as a change is approved by the Engineer.
- C. Where the conduits are to cross or be connected to existing conduit, make a field check to determine whether any conflict will be encountered in laying the new conduit.
  - 1. Adjust the location of new conduits, if necessary, as authorized by the Engineer, to avoid conflict with existing conduits.
- D. Where new conduits are to connect to existing conduits, provide all fittings required to complete the connection, and do the work as expeditiously and carefully as possible.
  - 1. Inspect and clean existing conduit prior to installing new wire.
- E. Remove and replace existing conduits, fittings, boxes, and all appurtenances as shown on the Drawings.
  - 1. Do not remove and replace existing items shown to remain unless approved by the Engineer.

### 3.6 CONDUIT USAGE SCHEDULE

- A. Install GRC when in contact with earth or fill unless otherwise shown on the Drawings.
- B. Install GRC or IMC in the following locations unless otherwise shown on the Drawings:
  - 1. Concealed in poured concrete walls and floor or roof slabs.
  - 2. Concealed in insulation above poured or precast concrete roof slabs.
  - 3. Exposed.
- C. EMT conduit may be installed in the following locations unless otherwise shown on the Drawings:
  - 1. Above suspended ceilings.
  - 2. In attic spaces.
  - 3. Concealed in walls, hollow metal or wood framed floors, ceilings, soffits, and overhangs.
  - 4. Concealed by counter base cabinets.
  - 5. Inside exterior electrical enclosures.
- D. Install liquidtight flexible metal conduit and fittings for connections to motors, instrumentation, transformers (primary and secondary connections), and equipment subject to vibration and at locations shown on the Drawings.

- E. Install PVC coated galvanized rigid steel conduit, rigid aluminum conduit, and rigid non-metallic conduit only when shown on the Drawings.

### 3.7 EXPOSED OUTLET AND JUNCTION BOXES

- A. Use cast boxes up to 45 inches above floor.
- B. Pressed steel boxes acceptable over 45 inches above floor in dry, indoor locations.
- C. Install weatherproof outlet, switch, and junction boxes outdoors and in any area where Drawings show weatherproof (WP) wiring devices.

### 3.8 OUTLET BOX ACCESSORIES

- A. Provide outlet box accessories and mounting devices as required for each installation.

### 3.9 OUTLET BOX LOCATIONS

- A. Location of outlets and equipment is approximate. Exact location to be verified and determined by:
  - 1. Conflict with equipment of other trades.
  - 2. Equipment manufacturer's drawings.
  - 3. Engineer in field.
- B. Minor modification in location of outlets and equipment is considered incidental up to distance of 10 feet with no additional compensation, providing necessary instructions are given prior to roughing-in of outlet boxes and equipment.
- C. Nominal mounting heights for devices and equipment to be measured from either above finished floor (AFF) or above finished grade (AFG) to center line of device and, unless otherwise shown on the Drawings, are as follows:
  - 1. Switches: 48 inches AFF OR AFG.
  - 2. AC receptacles and telephone outlets: 48 inches AFF or AFG.
  - 3. Thermostats: 60 inches above floor.

END OF SECTION

SECTION 26 05 53

IDENTIFICATION FOR ELECTRICAL SYSTEMS

PART 1 - GENERAL

1.1 SUMMARY

- A. Provide identification for electrical systems as shown on the Drawings, as specified herein, and as needed for a complete and proper installation.
- B. Related work:
  - 1. Documents affecting work under this Section include, but are not necessarily limited to, General Conditions, Supplementary Conditions, and Division 01 - General Requirements of these Specifications.
- C. References:
  - 1. Reserved.

1.2 SUBMITTALS

- A. Shop Drawing Submittals – None Required.
- B. Operation and Maintenance Manuals – None Required.
- C. Certificates and Guarantees – None Required.
- D. Spare Parts – None Required.

1.3 QUALITY ASSURANCE – Reserved.

1.4 DELIVERY, STORAGE, AND HANDLING

- A. Comply with pertinent provisions of Section 01 66 11.

1.5 SITE CONDITIONS – Reserved.

1.6 MAINTENANCE – Reserved.

PART 2 - PRODUCTS

2.1 NAMEPLATES AND TAGS

- A. Provide nameplates or tags for identification of panels, panel components, and field mounted devices with the following requirements.
  - 1. Engraved laminated plastic.

2. White or black letters on background of opposite color. Match and coordinate color of nameplate or tag background with other panels.
- B. Panel nameplates to have 1/2-inch high letter engraving.
  - C. Device and component nameplates or tags to have 3/16-inch high letter engraving.
  - D. Engravings include the following:
    1. Alpha-numeric number.
    2. Descriptive title.
    3. Range, where applicable.
    4. Engineering units, where applicable.

### PART 3 - EXECUTION

#### 3.1 INSTALLATION

- A. Install nameplates and tags on enclosures, panel mounted components, and field mounted devices.

END OF SECTION

## SECTION 26 09 13

## ELECTRICAL POWER MONITORING AND CONTROL

## PART 1 - GENERAL

## 1.1 SUMMARY

- A. Provide power monitoring and protection as shown on the Drawings, as specified herein, and as needed for a complete and proper installation.
- B. Related work:
  - 1. Documents affecting work under this Section include, but are not necessarily limited to, General Conditions, Supplementary Conditions, and Division 01 - General Requirements of these Specifications.
- C. References:
  - 1. Reserved.

## 1.2 SUBMITTALS

- A. Shop Drawing Submittals – None Required.
- B. Operation and Maintenance Manuals – None Required.
- C. Certificates and Guarantees – None Required.
- D. Spare Parts – None Required.
- E. Submit shop drawings in compliance with pertinent provisions of Section 01 33 01 including electrical ratings, and manufacturer's detailed specifications.

## 1.3 QUALITY ASSURANCE

- A. Comply with the following requirements:
  - 1. NFPA 70 National Electrical Code (NEC).
  - 2. Local codes and ordinances.

## 1.4 DELIVERY, STORAGE, AND HANDLING

- A. Comply with pertinent provisions of Section 01 66 11.

## 1.5 SITE CONDITIONS – Reserved.

## 1.6 MAINTENANCE – Reserved.

## PART 2 - PRODUCTS

### 2.1 GENERAL

- A. Provide a microprocessor based power monitor and protection instrument.
  - 1. Front panel mounting style.
  - 2. Compatible with PLC communication protocol as shown on the Drawings.
- B. Provide multi-function, 3 phase monitor that measures and displays the following power system information:
  - 1. True RMS currents, including neutral current.
  - 2. Voltages, both line-to-line and line-to-neutral.
  - 3. KVA, KW, and KVAR.
  - 4. Power factor.
  - 5. Frequency.
  - 6. KW hour and KVAR hour.
  - 7. KW demand and amps demand.
- C. Provide non-volatile memory for set-up parameters and historical data storage.

### 2.2 MULTI-FUNCTION POWER MONITOR AND PROTECTION INSTRUMENT

- A. Provide a multi-function power monitor and protection instrument that includes:
  - 1. Three (3) Form C alarm relay outputs.
  - 2. Minimum accuracies as follows:
    - a. Voltage and current: 0.35 percent.
    - b. Power: 0.5 percent.
    - c. Power factor: 1.0 percent.
    - d. Frequency:  $\pm 0.2$  Hertz.
- B. Acceptable manufacturers:
  - 1. Square D, Model PM800 Series.
  - 2. Allen-Bradley, Bulletin 1400.
  - 3. Power Measurement, Ltd., Model 3710 ACM.
  - 4. Electro Industries/Gaugetech, Model DMMS-300.
  - 5. Or equal.

### 2.3 THREE PHASE DIGITAL MONITOR

- A. Provide a dual-display, multi-function meter for measuring 3 phase volts and amps.
- B. Acceptable manufacturers:
  - 1. Electro Industries/Gaugetech, Model DMVA-100.
  - 2. Or equal.

### 2.4 COMMUNICATIONS MODULE

- A. Provide communication module as required to allow integration into a PLC communication network as shown on the Drawings.



PART 3 - EXECUTION

3.1 INSTALLATION

- A. Install power monitoring and protection instrument in accordance with manufacturer's recommendations.
- B. Program setpoints to activate alarm relays as follows:
  - 1. Overvoltage: 110 percent.
  - 2. Undervoltage: 90 percent.
  - 3. Voltage unbalance: 7 percent.
  - 4. Phase reversal.

END OF SECTION

SECTION 26 09 95

PUSHBUTTONS, SELECTOR SWITCHES, AND PILOT LIGHTS

PART 1 - GENERAL

1.1 SUMMARY

- A. Provide pushbuttons, selector switches, and pilot lights as shown on the Drawings, as specified herein, and as needed for a complete and proper installation.
- B. Related work:
  - 1. Documents affecting work under this Section include, but are not necessarily limited to, General Conditions, Supplementary Conditions, and Division 01 - General Requirements of these Specifications.
- C. References:
  - 1. Reserved.

1.2 SUBMITTALS

- A. Shop Drawing Submittals:
  - 1. Manufacturer's detailed specifications.
- B. Operation and Maintenance Manuals – None Required.
- C. Certificates and Guarantees – None Required.
- D. Spare Parts:
  - 1. Two (2) pilot light lamps of each type.

1.3 QUALITY ASSURANCE

- A. Comply with the following requirements:
  - 1. NFPA 70, National Electrical Code (NEC).
  - 2. Local codes and ordinances.

1.4 DELIVERY, STORAGE, AND HANDLING

- A. Comply with pertinent provisions of Section 01 66 11.

1.5 SITE CONDITIONS – Reserved.

1.6 MAINTENANCE – Reserved.

## PART 2 - PRODUCTS

### 2.1 GENERAL

- A. Provide oil-tight, heavy duty NEMA 4 rated pushbutton switches, selector switches, and pilot lights.
- B. Provide all devices with legend plates.
  - 1. Material: Non-tarnish metal or laminated plastic.
  - 2. Use white or black letters on background of opposite color for laminated plastic.
- C. Use two-circuit contact blocks (one N.O. and one N.C. contact set) for pushbutton switches and selector switches.

### 2.2 PUSHBUTTON SWITCHES

- A. Stop pushbuttons:
  - 1. Provide non-illuminated momentary operation type operators.
  - 2. Use red color button.
- B. Start pushbuttons:
  - 1. Provide non-illuminated momentary operation type operators.
  - 2. Use black color button.
- C. Stop-hold switches:
  - 1. Use stop pushbutton as specified above.
  - 2. Include sliding latch with padlock provision to engage stop button in the OFF position.
- D. Provide pushbuttons for other functions as shown on the Drawings.

### 2.3 SELECTOR SWITCHES

- A. Provide selector switches including the operating knob, operating cam and contact block(s).
- B. Use black color operating knob.
- C. Select operating cam and contact block combination to provide operating sequence as required.

### 2.4 PILOT LIGHTS

- A. Provide pilot lights with colored plastic lens as shown on the Drawings.
- B. Provide 120 volt or 24 Vdc, push-to-test type with LED lamp.

## 2.5 ENCLOSURES

- A. Provide for individual remote control or monitor stations the following type enclosure:
  - 1. Indoor locations: NEMA 1.
  - 2. Outdoor or wet locations: NEMA 3R or NEMA 4 steel construction.
  - 3. Corrosive locations: NEMA 4X stainless steel construction.
  
- B. Provide nameplate on enclosure for device being controlled.
  - 1. Provide engraved laminated plastic type.
  - 2. Use 3/16-inch high white or black letters on background of opposite color.

## PART 3 - EXECUTION

### 3.1 INSTALLATION

- A. Install pushbutton switches, selector switches, and pilot lights in accordance with manufacturer's recommendations.

END OF SECTION

SECTION 26 22 13

LOW VOLTAGE DISTRIBUTION TRANSFORMERS

PART 1 - GENERAL

1.1 SUMMARY

- A. Provide transformers as shown on the Drawings, as specified herein, and as needed for a complete and proper installation.
- B. Related work:
  - 1. Documents affecting work under this Section include, but are not necessarily limited to, General Conditions, Supplementary Conditions, and Division 01 - General Requirements of these Specifications.
- C. References:
  - 1. Reserved.

1.2 SUBMITTALS

- A. Shop Drawing Submittals:
  - 1. Physical dimensions, nameplate data, electrical ratings, and manufacturer's detailed specifications.
- B. Operation and Maintenance Manuals – None Required.
- C. Certificates and Guarantees – None Required.
- D. Spare Parts – None Required.

1.3 QUALITY ASSURANCE

- A. Comply with the following requirements:
  - 1. NFPA 70 National Electrical Code (NEC).
  - 2. Local codes and ordinances.

1.4 DELIVERY, STORAGE, AND HANDLING

- A. Comply with pertinent provisions of Section 01 66 11.

1.5 SITE CONDITIONS – Reserved.

1.6 MAINTENANCE – Reserved.

## PART 2 - PRODUCTS

### 2.1 GENERAL PURPOSE TRANSFORMERS

- A. Provide transformers manufactured and tested to meet or exceed NEMA ST 20, UL 1562, ANSI C57.12, and IEEE standards.
- B. Provide KVA rating and voltages as shown on the Drawings.
- C. Provide overload capacity of not less than 10 percent for intermittent operation.
- D. Construct transformer to include:
  - 1. Below 30 KVA: Class F or better insulation having a 115 degree C. rise average maximum over a 40 degree C. ambient temperature.
  - 2. 30 KVA and above: Class H or better insulation having a 150 degree C. rise average maximum over a 40 degree C. ambient temperature.
  - 3. High grade, non-aging cores with sheet silicone steel laminations having core plating insulation on both sides of each lamination.
  - 4. Two 2-1/2 percent primary taps above and below nominal voltage.

### 2.2 CONTROL TRANSFORMERS

- A. Provide UL listed transformers designed to handle high in-rush currents associated with contactors and relays.
- B. Provide continuous VA rating: Size for 1.25 times capacity required for all components in circuit.

## PART 3 - EXECUTION

### 3.1 INSTALLATION

- A. Install transformers in accordance with manufacturer's recommendations.
- B. Adjust voltage taps for required system voltage when necessary.

END OF SECTION

## SECTION 26 24 16

### PANELBOARDS

#### PART 1 - GENERAL

##### 1.1 SUMMARY

- A. Provide panelboards as shown on the Drawings, as specified herein, and as needed for a complete and proper installation.
- B. Related work:
  - 1. Documents affecting work under this Section include, but are not necessarily limited to, General Conditions, Supplementary Conditions, and Division 01 - General Requirements of these Specifications.
- C. References:
  - 1. Reserved.

##### 1.2 SUBMITTALS

- A. Shop Drawing Submittals:
  - 1. Cabinet dimensions.
  - 2. Nameplate nomenclature.
  - 3. Electrical ratings and characteristics.
  - 4. Type, amperage rating, listing, and position of circuit breakers in panelboard.
  - 5. Manufacturer's detailed specifications.
- B. Operation and Maintenance Manuals – None Required.
- C. Certificates and Guarantees – None Required.
- D. Spare Parts – None Required.

##### 1.3 QUALITY ASSURANCE

- A. Comply with the following requirements:
  - 1. NFPA 70 National Electrical Code (NEC).
  - 2. Local codes and ordinances.
  - 3. Provide all panelboards of one manufacturer.

##### 1.4 DELIVERY, STORAGE, AND HANDLING

- A. Comply with pertinent provisions of Section 01 66 11.

##### 1.5 SITE CONDITIONS – Reserved.

##### 1.6 MAINTENANCE – Reserved.

## PART 2 - PRODUCTS

### 2.1 GENERAL

- A. Comply with the following standards:
  - 1. NEMA AB 1 - Molded Case Circuit Breakers and Molded Case Switches.
  - 2. NEMA FU 1 - Low Voltage Cartridge Fuses.
  - 3. NEMA ICS 2 - Industrial Control and Systems: Controllers, Contactors, and Overload Relays, Rated Not More Than 2000 Volts AC or 750 Volts DC.
  - 4. NEMA ICS 5 - Industrial Control and Systems: Control Circuit and Pilot Devices.
  - 5. NEMA KS 1 - Enclosed and Miscellaneous Distribution Equipment Switches (600 Volts Maximum).
  - 6. NEMA PB 1 - Panelboards.
  - 7. NEMA PB 1.1 - General Instructions for Proper Installation, Operation, and Maintenance of Panelboards Rated 600 Volts or less.
- B. Comply with the requirements of UL 50, 67, and NEMA PB1 standards.
- C. Provide short circuit rating (integral equipment rating) for available fault current.
- D. Provide panelboard construction with the following:
  - 1. Neutral bus with terminals.
  - 2. Plated or tinned copper bussing:
    - a. Distributed phase sequence type.
    - b. Ratings as shown on the Drawings, 100 ampere minimum.
  - 3. Branch circuit breakers:
    - a. Comply with Section 26 28 00.
    - b. Ratings as shown on the Drawings.
    - c. UL Class A ground fault circuit protection (GFP) as required.
  - 4. Circuit directory:
    - a. Directory card suitable for complete descriptions.
    - b. Clear plastic cover.
    - c. Card holder attached to inside of panel door.
- E. Provide main lugs or main circuit breaker rated as shown on the Drawings.
  - 1. Main circuit breaker: Comply with Section 26 28 00.
- F. Listed for non-linear loads.

### 2.2 MCC MOUNTED PANELBOARDS

- A. Provide front to match MCC construction and painting, including the following:
  - 1. Dead front safety type.
  - 2. Concealed adjustable trim clamps.
  - 3. Concealed hinges.
- B. Provide nameplate to match MCC nameplates identifying panelboard.



PART 3 - EXECUTION

3.1 INSTALLATION

- A. Install panelboards in accordance with manufacturer's recommendations.

3.2 RESTRICTIONS

- A. Separation of hot wires and respective neutral wires where they enter a panelboard is not permitted.
  - 1. All ungrounded and grounded (hot and neutral) conductors of each feeder circuit and each branch circuit must be grouped together where they enter through knock-outs or slots into a panelboard gutter area.
  - 2. Comply with N.E.C. Section 300.20.

3.3 FIELD QUALITY CONTROL

- A. Energize each circuit and check for complete and correct function.

END OF SECTION

SECTION 26 24 19

MOTOR-CONTROL CENTERS

PART 1 - GENERAL

1.1 SUMMARY

- A. Provide custom fabricated motor control center (MCC) as shown on the Drawings, as specified herein, and as needed for a complete and proper installation.
- B. Related work:
  - 1. Documents affecting work under this Section include, but are not necessarily limited to, General Conditions, Supplementary Conditions, and Division 01 - General Requirements of these Specifications.
- C. References:
  - 1. Reserved.

1.2 SUBMITTALS

- A. Shop Drawing Submittals:
  - 1. Schematic diagrams for each compartment.
  - 2. Wiring and interconnection diagrams.
  - 3. Frontal elevation and dimension drawings.
  - 4. Listing of ratings, sizes and style of all components, including bus work.
  - 5. Nameplate listings.
  - 6. Manufacturer's detailed specifications.
- B. Operation and Maintenance Manuals – Submit operation and maintenance manuals in compliance with pertinent provisions of Section 01 78 26.
- C. Certificates and Guarantees – None Required.
- D. Lubricants – None Required.
- E. Spare Parts – None Required.

1.3 QUALITY ASSURANCE

- A. Comply with the following requirements:
  - 1. NFPA 70 National Electrical Code (NEC).
  - 2. Local codes and ordinances.

1.4 DELIVERY, STORAGE, AND HANDLING

- A. Comply with pertinent provisions of Section 01 66 11.

1.5 SITE CONDITIONS – Reserved.

1.6 MAINTENANCE – Reserved.

## PART 2 - PRODUCTS

### 2.1 GENERAL

- A. Comply with pertinent requirements of UL 845 and NEMA ICS-18.
- B. Rating: 480Y/277 volt, 3 phase, 4 wire, 60 Hertz AC.
- C. Provide individual units in MCC sized, rated and arranged as shown on the Drawings and as specified herein.
- D. Acceptable manufacturer:
  - 1. Altronex Control Systems Division of L.W. Allen, Inc.
  - 2. No substitutions permitted.

### 2.2 MATERIAL AND EQUIPMENT

- A. Provide structure as follows:
  - 1. Sectionalized NEMA-1A gasketed construction of one or more totally enclosed, dead front, vertical sections joined together to form a rigid, free-standing assembly.
  - 2. Lifting angles or eye hooks on top surface of each section.
  - 3. Prime coated, baked enamel finish.
  - 4. Open bottom for entry of existing conduits as shown on the Drawings.
  - 5. Overall size not to exceed maximum dimensions shown on the Drawings.
  - 6. Labeled to indicate suitability for use as service entrance equipment.
- B. Provide bus bars and terminations as follows:
  - 1. Front accessible, silver or tin plated copper braced to withstand a fault current of 42,000 RMS symmetrical amperes.
  - 2. Minimum 800 amp horizontal bus or distribution terminal block.
  - 3. Continuous horizontal ground bus in bottom and/or top of MCC.
  - 4. Provide line and load terminations accessible from front, suitable for the size, number of conductors, and conductor material as shown on the Drawings.
- C. Provide wiring as follows:
  - 1. NEMA Class II, Type B wiring.
  - 2. Label all wiring/cables in the MCC at both ends and with labels as specified in Section 26 05 19.
- D. Provide incoming section as follows:
  - 1. Switch-fuse-meter sequence.
  - 2. Hinged padlockable covers for main circuit breaker and current-transformer compartment.

3. Comply with Section 26 28 00 for main circuit breaker.
    - a. Continuous rating and trip rating as shown on the Drawings.
    - b. Auxiliary contact set as shown on the Drawings.
  4. Comply with Madison Gas and Electric Company (MG&E) requirements for current-transformer compartment.
  5. Full capacity neutral bus with main bonding jumper/link.
- E. Provide automatic transfer switch section as follows:
1. Comply with Section 26 36 00.
- F. Provide molded case thermal-magnetic circuit breakers as follows:
1. Comply with Section 26 28 00.
- G. Provide operating handles for circuit breakers (except panelboard circuit breakers) as follows:
1. Engaged with device at all times.
  2. Up and down motion with down as OFF.
  3. Interlocked with unit door.
  4. Provisions for padlocking in off position.
- H. Provide transformers as follows:
1. Comply with Section 26 22 13.
- I. Provide panelboards as follows:
1. Comply with Section 26 24 16.
- J. Provide combination reduced-voltage motor controllers as follows:
1. Comply with Section 26 29 13.16.
- K. Provide variable-frequency motor controller as follows:
1. Comply with Section 26 29 23.
- L. Provide surge-protective devices as follows:
1. Comply with Section 26 43 00.
- M. Provide engraved laminated plastic identification nameplates as follows:
1. Use 3/16-inch high white or black letters and numbers on background of opposite color.
- N. Provide pushbuttons, selector switches and pilot lights as follows:
1. Comply with Section 26 09 95.
- O. Provide control devices as indicated on the Drawings and same functionality as systems provided at other Madison Water Utility sites by Altronex Control Systems Division of L.W. Allen, Inc.

PART 3 - EXECUTION

3.1 INSTALLATION

- A. Install MCC in accordance with manufacturer's recommendations.
- B. Install on concrete pad as shown on the Drawings, and secure with steel bolts.

3.2 ADJUSTMENT AND CLEANING

- A. Furnish to Owner one can spray paint matching original finish for future touch-up as required.

END OF SECTION

SECTION 26 27 26

WIRING DEVICES

PART 1 - GENERAL

1.1 SUMMARY

- A. Provide wiring devices as shown on the Drawings, as specified herein, and as needed for a complete and proper installation.
- B. Related work:
  - 1. Documents affecting work under this Section include, but are not necessarily limited to, General Conditions, Supplementary Conditions, and Division 01 - General Requirements of these Specifications.
- C. References:
  - 1. Reserved.

1.2 SUBMITTALS

- A. Shop Drawing Submittals – None Required.
- B. Operation and Maintenance Manuals – None Required.
- C. Certificates and Guarantees – None Required.
- D. Spare Parts – None Required.

1.3 QUALITY ASSURANCE

- A. Comply with the following requirements:
  - 1. NFPA 70 National Electrical Code (NEC).
  - 2. Local codes and ordinances.

1.4 DELIVERY, STORAGE, AND HANDLING

- A. Comply with pertinent provisions of Section 01 66 11.

1.5 SITE CONDITIONS – Reserved.

1.6 MAINTENANCE – Reserved.

PART 2 - PRODUCTS

2.1 GENERAL

- A. Provide wiring devices in type and electrical rating for service indicated.

- B. See symbol schedule on Drawings for identification of device type.
- C. Acceptable manufacturers:
  - 1. Hubbell.
  - 2. Leviton.
  - 3. Or equal.

## 2.2 SWITCHES

- A. General use lighting switches:
  - 1. Comply with UL 20, NEMA WD-1, and Federal Specification W-S-896 standards.
  - 2. Provide industrial grade, 20 ampere, toggle type switches.

## 2.3 RECEPTACLES

- A. Comply with UL 498, NEMA WD-1 & WD-6, and Federal Specification W-C-596 standards.
- B. General use single and duplex, 125 volt receptacles:
  - 1. Provide industrial grade, NEMA 5-20R grounding type receptacles rated at 20 amperes.
- C. Ground fault circuit interrupter receptacles:
  - 1. Comply with UL 943 Class A standard.
  - 2. Provide industrial grade, GFCI duplex receptacles rated at 20 amperes, 120 volts.
  - 3. Provide construction as follows:
    - a. Shallow depth and NEMA 5-20R configuration.
    - b. Feed-through feature.

## 2.4 WIRING DEVICE PLATES AND COVER

- A. Comply with UL 514D.
- B. Plates of interior flush mounted devices: Provide high impact thermoplastic polycarbonate, nylon or stainless steel.
- C. Device plates for surface mounted Type FS or FD boxes: Provide type FSK galvanized steel covers.
- D. Device plates for surface mounted, 4-inch square boxes: Provide 1/2-inch raised galvanized steel covers.
- E. Weatherproof (WP) plates and covers: Provide with gasketed, lift cover.
  - 1. Provide lift cover designed to be fully closed when plug for dedicated equipment is inserted in receptacle.

PART 3 - EXECUTION

3.1 INSTALLATION

- A. Install wiring devices in accordance with manufacturer's recommendations.
- B. Install gasket plates for devices or system components having light emitting features, such as switch with pilot light.
- C. Install devices at height as specified in Section 26 05 33 or as shown on the Drawings.
- D. Do not use combination type switch/switch or switch/receptacle devices.
  - 1. Provide separate box gang for each switch and receptacle.
- E. Thoroughly clean box interiors from construction dust, debris, etc. prior to installing wiring devices.

3.2 FIELD QUALITY CONTROL

- A. Provide operational testing for devices.
- B. Test receptacles for correct polarity, proper ground connection, and wiring faults.

END OF SECTION



## SECTION 26 28 00

## LOW-VOLTAGE CIRCUIT PROTECTIVE DEVICES

## PART 1 - GENERAL

## 1.1 SUMMARY

- A. Provide overcurrent protective devices as shown on the Drawings, as specified herein, and as needed for a complete and proper installation.
- B. Related work:
  - 1. Documents affecting work under this Section include, but are not necessarily limited to, General Conditions, Supplementary Conditions, and Division 01 - General Requirements of these Specifications.
- C. References:
  - 1. Reserved.

## 1.2 SUBMITTALS

- A. Shop Drawing Submittals:
  - 1. Electrical ratings, physical size, interrupt ratings, trip curves, I<sup>2</sup>t curves, and manufacturer's detailed specifications.
- B. Operation and Maintenance Manuals – None Required.
- C. Certificates and Guarantees – None Required.
- D. Lubricants – None Required.
- E. Spare Parts – Provide the following spare parts to the Owner that match items specified:
  - 1. In three phase circuits: Three (3) fuses of each type and rating.
  - 2. In single phase circuits: Two (2) fuses of each type and rating.

## 1.3 QUALITY ASSURANCE

- A. Comply with the following requirements:
  - 1. NFPA 70 National Electrical Code (NEC).
  - 2. Local codes and ordinances.
  - 3. Provide overcurrent protective devices by same manufacturer for each type of device.

## 1.4 DELIVERY, STORAGE, AND HANDLING

- A. Comply with pertinent provisions of Section 01 66 11.

1.5 SITE CONDITIONS – Reserved.

1.6 MAINTENANCE – Reserved.

## PART 2 - PRODUCTS

### 2.1 FUSES

- A. General purpose fuses for protection of motor control circuits, lighting ballasts, control transformers, and street lighting fixtures:
  - 1. Use UL Class CC, fast acting, single element fuses.
  - 2. Rated for 0-30 amperes.
  - 3. Provide 200,000 ampere interrupting capacity.
  - 4. Use Bussman Limitron KTK-R, or equal: 600 volt rating.

### 2.2 MOLDED CASE CIRCUIT BREAKERS

- A. General:
  - 1. Comply with UL 489 requirements.
  - 2. Provide thermal and magnetic protection.
- B. Provide permanent trip lighting panel circuit breakers as follows:
  - 1. UL listed SWD (switching duty) on 120 volt circuits where switched circuits are indicated.
  - 2. Short circuit rating (integrated equipment rating):
    - a. Up to 240 volt: 10,000 RMS symmetrical amps minimum.
    - b. Up to 480 volt: 14,000 RMS symmetrical amps minimum.
- C. Provide permanent trip power panel and MCC circuit breakers as follows:
  - 1. Single magnetic trip adjustment.
  - 2. Bolt-on type.
  - 3. Short circuit rating (integrated equipment rating):
    - a. Main: 42,000 RMS symmetrical amps minimum.
    - b. Branch: 14,000 RMS symmetrical amps minimum.

## PART 3 - EXECUTION

### 3.1 INSTALLATION

- A. Install overcurrent protective devices in accordance with manufacturer's recommendations.

### 3.2 ADJUSTMENT

- A. Set and record adjustable settings on circuit breakers to provide selective coordination and proper operation.

END OF SECTION

SECTION 26 28 16

ENCLOSED SWITCHES AND CIRCUIT BREAKERS

PART 1 - GENERAL

1.1 SUMMARY

- A. Provide enclosed switches and circuit breakers as shown on the Drawings, as specified herein, and as needed for a complete and proper installation.
- B. Related work:
  - 1. Documents affecting work under this Section include, but are not necessarily limited to, General Conditions, Supplementary Conditions, and Division 01 - General Requirements of these Specifications.
- C. References:
  - 1. Reserved.

1.2 SUBMITTALS

- A. Shop Drawing Submittals:
  - 1. Electrical ratings, physical dimensions, NEMA rating, and manufacturer's detailed specifications.
- B. Operation and Maintenance Manuals – None Required.
- C. Certificates and Guarantees – None Required.
- D. Spare Parts – None Required.

1.3 QUALITY ASSURANCE

- A. Comply with the following requirements:
  - 1. NFPA 70 National Electrical Code (NEC).
  - 2. Local codes and ordinances.

1.4 DELIVERY, STORAGE, AND HANDLING

- A. Comply with pertinent provisions of Section 01 66 11.

1.5 SITE CONDITIONS – Reserved.

1.6 MAINTENANCE – Reserved.

## PART 2 - PRODUCTS

### 2.1 GENERAL

- A. Provide disconnect with the following ratings:
  - 1. 240 volt or 600 volt AC as required by circuit voltage.
  - 2. Ampere value as shown on Drawings.
  - 3. UL listed short circuit rating of 200,000 RMS amps with Class R fuses where a fused disconnect is indicated.
    - a. Comply with Section 26 28 00.

### 2.2 SAFETY SWITCH

- A. Provide NEMA heavy-duty, quick-make and quick-break type:
  - 1. Cover interlock mechanism with handle attached to box.
    - a. Handle position indication of ON in up position and OFF in down position.
  - 2. Padlock provision in the ON and OFF positions.
  - 3. Provisions for insulated or bonded neutral.
  - 4. Provision for control circuit interlock.

### 2.3 ENCLOSURES

- A. Indoor: Provide NEMA 1 steel construction.
- B. Outdoor area: Provide NEMA 3R or NEMA 4 steel construction.

### 2.4 NAMEPLATES

- A. Provide engraved laminated plastic type.
- B. Use 3/16-inch high white or black letters on background of opposite color.
- C. Identify disconnect means as follows:
  - 1. Disconnect: For purpose of switch or equipment controlled.

## PART 3 - EXECUTION

### 3.1 INSTALLATION

- A. Install motor and circuit disconnects in accordance with manufacturer's recommendations.

END OF SECTION

## SECTION 26 29 13.16

## REDUCED-VOLTAGE MOTOR CONTROLLERS

## PART 1 - GENERAL

## 1.1 SUMMARY

- A. Provide Solid State Reduced Voltage Starters (SSRVS) as shown on the Drawings, as specified herein, and as needed for a complete and proper installation.
- B. Related work:
  - 1. Documents affecting work under this Section include, but are not necessarily limited to, General Conditions, Supplementary Conditions, and Division 01 - General Requirements of these Specifications.
- C. References:
  - 1. Reserved.

## 1.2 SUBMITTALS

- A. Shop Drawing Submittals:
  - 1. Enclosure dimensions, nameplate data, electrical ratings and characteristics, wiring diagrams and manufacturer's detailed specifications.
- B. Operation and Maintenance Manuals – Submit operation and maintenance manuals in compliance with pertinent provisions of Section 01 78 26, including the following:
  - 1. Documentation showing final configuration of each SSRVS.
- C. Certificates and Guarantees – None Required.
- D. Lubricants – None Required.
- E. Spare Parts – None Required.

## 1.3 QUALITY ASSURANCE

- A. Comply with the following requirements:
  - 1. NFPA 70 (latest edition) - National Electrical Code (NEC).
  - 2. Local codes and ordinances.
  - 3. Furnish products listed and classified by Underwriters Laboratories, Inc. as suitable for purpose specified and indicated.

## 1.4 DELIVERY, STORAGE, AND HANDLING

- A. Comply with pertinent provisions of Section 01 66 11.

## 1.5 SITE CONDITIONS – Reserved.

## 1.6 MAINTENANCE – Reserved.

## PART 2 - PRODUCTS

### 2.1 GENERAL

- A. Design programmable microprocessor controlled SSRVS utilizing a thyristor (SCR) bridge consisting of at least two SCRs per phase to control starting and stopping of industry standard motors.
- B. Protect driven motor from solid state component failure by means of isolation contactor that opens when the motor is stopped or when the controller detects a fault condition including a shorted thyristor.
- C. All protective features and deceleration control options to be available even when a shorting contactor is employed.
- D. Provide complete with magnetic only circuit breaker for Type 1 short circuit protection. Short circuit withstand rating shall be based on the motor horsepower as defined in UL 508.
- E. Acceptable manufacturer:
  - 1. Allen-Bradley.
  - 2. No Substitution permitted.

### 2.2 RATINGS

- A. Provide SSRVS with the following ratings:
  - 1. Ambient temperature range: 0 to 40 degrees C.
  - 2. Humidity: 93% @ 40 degrees C, non-condensing.
  - 3. Voltage tolerance: +/- 10% of nominal rating.
  - 4. Frequency tolerance: +/- 5% starting, +5% or -15% steady state operation.
  - 5. Capable of supplying 300% rated full load current for 30 seconds at maximum ambient temperature.
  - 6. SCR P.I.V. rating: 1400 VAC (minimum).

### 2.3 ADJUSTMENTS AND CONFIGURATIONS

- A. Provide accessibility to all display units, configuration switches and adjustment potentiometers on the front of the control module. Exposure to control circuit boards or electrical power devices during routine adjustments is prohibited.
- B. Provide digital indication of the following as a minimum:
  - 1. SSRVS status – ready, starting/stopping, run.
  - 2. Motor status – current, torque, thermal state, power factor.
  - 3. Fault status.

- C. Provide SSRVS specifically designed to reduce surges during starting and stopping of centrifugal pumps.
- D. Provide built-in keypad to configure the following operating parameters.
  - 1. Motor full load amps.
  - 2. Current limitation on starting.
  - 3. Torque ramp.
  - 4. Initial torque.
  - 5. Torque limit.
  - 6. Maximum start time.
  - 7. Selection of freewheel, soft stop, or braking.
  - 8. Adjustable soft stop torque ramp time.
  - 9. Selection of Class 10 and 20 motor thermal overload protection.

## 2.4 INPUTS AND OUTPUTS

- A. Provide the following output relays:
  - 1. One Form A and one Form B minimum for indication of fault or control of an isolation contactor.
  - 2. One Form A for indication that torque ramp is complete and current is below 130% motor FLA (End of start).
  - 3. One Form A for indication of FAULT status to remote Pump Control Panel.
- B. Provide the following additional I/O:
  - 1. One logic input for force to freewheel, indication of external fault, force to local control, or external motor overload reset.
  - 2. One analog output for 4-20 or 0-20 milliamp indication of motor current, torque, thermal state or power factor.
- C. Provide relay and I/O functions listed above isolated with respect to common.

## 2.5 PROTECTION

- A. Provide microprocessor controlled thermal protection system which continuously calculates the temperature-rise of the motor and SSRVS and provides:
  - 1. An overload pre-alarm which indicates by relay contact that the motor has exceeded its rated temperature rise by 110%.
  - 2. A thermal fault condition which stops the motor if the temperature-rise exceeds 120% of the motor thermal capability.
  - 3. An analog electronic circuit with a time constant adjustable to the motor's thermal cooling time constant ensuring the memorization of the thermal state even after power supply disconnection or shorting out of the power semiconductors.
- B. Provide phase loss, phase reversal, under-load, stall, and jam protection.

## 2.6 CONTROLS

- A. Provide control transformer within the enclosure to operate soft start control circuitry 120 Vac, 60 Hz.
- B. Provide door-mounted operator devices as shown on the Drawings.
- C. Provide communication module to communicate with PLC as specified in Section 40 94 43 and as shown on Drawings.

## PART 3 - EXECUTION

### 3.1 INSTALLATION

- A. Install SSRVS in electrical enclosures or motor control centers as shown on the Drawings and in accordance with manufacturer's recommendations.

### 3.2 FIELD QUALITY CONTROL

- A. Conduct field tests prior to energization per manufacturers recommendations.
- B. Record and provide results of tests to Engineer.

### 3.3 START-UP AND TESTING

- A. Provide programming, calibration and operational testing.
- B. Set operating parameters as required.

END OF SECTION



## SECTION 26 29 23

## VARIABLE-FREQUENCY MOTOR CONTROLLERS

## PART 1 - GENERAL

## 1.1 SUMMARY

- A. Provide variable frequency motor drives as shown on the Drawings, as specified herein, and as needed for a complete and proper installation.
- B. Related work:
  - 1. Documents affecting work under this Section include, but are not necessarily limited to, General Conditions, Supplementary Conditions, and Division 01 - General Requirements of these Specifications.
- C. References:
  - 1. Reserved.

## 1.2 SUBMITTALS

- A. Shop Drawing Submittals:
  - 1. Enclosure dimensions, nameplate data, electrical ratings and characteristics, wiring diagrams and manufacturer's detailed specifications.
- B. Operation and Maintenance Manuals – Submit operation and maintenance manuals in compliance with pertinent provisions of Section 01 78 26, including the following:
  - 1. Harmonic distortion analysis which includes the following:
    - a. Calculations of percent voltage distortion with respect to the fundamental voltage on the line side bus.
    - b. Comparison of calculations with IEEE-519 standards for acceptable harmonic distortions.
  - 2. Documentation showing final configuration of each motor drive.
- C. Certificates and Guarantees – None Required.
- D. Lubricants – None Required.
- E. Spare Parts – None Required.
- F. Provide factory operational test, heat test, and reports for motor loading at various speeds simulating field loading.

## 1.3 QUALITY ASSURANCE

- A. Comply with the following requirements:
  - 1. NFPA 70 (latest edition) - National Electrical Code (NEC).
  - 2. Local codes and ordinances.

## VARIABLE-FREQUENCY MOTOR CONTROLLERS

26 29 23-1 (140218.40)

3. IEEE 519 (latest version).
4. FCC 15J.

1.4 DELIVERY, STORAGE, AND HANDLING

- A. Comply with pertinent provisions of Section 01 66 11.

1.5 SITE CONDITIONS – Reserved.

1.6 MAINTENANCE – Reserved.

PART 2 - PRODUCTS

2.1 GENERAL

- A. Design programmable microprocessor based, pulse width modulated (PWM) IGBT type variable frequency AC drives to provide adjustable speed control of 3-phase motors.
- B. Acceptable manufacturer:
1. Allen-Bradley, PowerFlex 70/700.
  2. No substitution permitted.

2.2 VARIABLE FREQUENCY DRIVE (VFD)

- A. Provide VFD as follows:
1. Design for constant torque motor or variable torque motor application as shown on the Drawings.
  2. Input power: 480 volt, 3 phase, 60 Hz.
    - a. Able to withstand voltage variations of +/-10 percent, and 3 percent maximum phase imbalance without affecting performance.
    - b. Displacement power factor to be 0.95 lagging, minimum.
    - c. Performance to be unaffected by line notching, transients, and harmonics on incoming line.
    - d. Minimum efficiency at rated load to be 97 percent.
  3. Output power: Capable of horsepower rating and service factor of motors furnished.
    - a. To include automatic function that will modify the volts/Hertz curve based on light load characteristics to minimize power consumption.
  4. Removable Human Interface Module (HIM) with keypad and LCD display to be used for all setup, operation, parameter adjustment, and monitoring.
  5. Control Interface:
    - a. Provides means of interfacing discrete signals to drive.
    - b. Voltage Rating: 120VAC or 24VDC as required for application.
  6. Communication module:
    - a. Compatible with communication protocol as shown on the Drawings.
    - b. Able to accept four (4) additional discrete inputs.

7. Hand-Off-Auto selector switch as shown on the Drawings.
    - a. Provide extra contact blocks for remote indication of selector switch position (Hand and Auto).
  8. Pilot lights for drive status as shown on the Drawings.
  9. Combination type having main circuit breaker, or fused disconnect switch as shown on the Drawings.
    - a. Include SCR fuses when recommended by manufacturer.
  10. Control transformer: 480 – 120 volt A.C. with primary and secondary fuse protection.
  11. Input terminals for connection of motor winding heat sensor control wires and remote stop switch control wires.
    - a. Jumper on input terminals when heat sensors and/or user supplied stop pushbuttons are not shown on the Drawings.
  12. Programmable time delay to restart the drive when power is restored.
- B. Provide VFD with the following as shown on the Drawings:
1. Line reactor.
  2. Motor terminator.

### PART 3 - EXECUTION

#### 3.1 INSTALLATION

- A. Install motor drives in motor control center as shown on the Drawings and in accordance with manufacturer's recommendations.
- B. Coordinate parameter settings with supplier of process control panels.

#### 3.2 FIELD QUALITY CONTROL

- A. Conduct field tests prior to energization as follows:
  1. Megger check wire insulation levels (do not megger check solid state equipment).
  2. Record and provide results of tests to Engineer.

#### 3.3 START-UP AND TESTING

- A. Provide programming, calibration, and operational testing.
- B. Set operating parameters as required.

END OF SECTION

SECTION 26 32 13.33

DIESEL FUELED ENGINE-GENERATORS

PART 1 - GENERAL

1.1 SUMMARY

- A. Provide diesel fueled engine-generators with sound enclosure as shown on the Drawings, as specified herein, and as needed for a complete and proper installation.
- B. Related work:
  - 1. Documents affecting work under this Section include, but are not necessarily limited to, General Conditions, Supplementary Conditions, and Division 01 - General Requirements of these Specifications.
- C. References:
  - 1. Reserved.

1.2 SUBMITTALS

- A. Shop Drawing Submittals:
  - 1. Submit shop drawings in compliance with pertinent provisions of Section 01 33 01.
  - 2. Engine-generator set, exhaust system, cooling system, control panel, auxiliary equipment, controls, stairs, railings, landing platform, sound enclosure, concrete base and manufacturer's detailed specifications.
- B. Operation and Maintenance Manuals – Submit operation and maintenance manuals in compliance with pertinent provisions of Section 01 78 26.
- C. Certificates and Guarantees – None Required.
- D. Lubricants – None Required.
- E. Permits – Obtain Operating Air Quality Permit for Generator
- F. Spare Parts – None Required
- G. Test reports:
  - 1. Submit certified test reports of prototype and production tests.
  - 2. Submit field test reports on engine-generator start-up.

1.3 QUALITY ASSURANCE

- A. Comply with the following requirements:
  - 1. NFPA 70, National Electrical Code (NEC).
  - 2. NFPA 110, Emergency and Standby Power Systems.

3. Local codes and ordinances.
4. Conduct factory prototype tests.
5. Conduct factory production tests simulating the field load conditions and verify proper operation of all components prior to shipping equipment.

#### 1.4 DELIVERY, STORAGE, AND HANDLING

- A. Comply with pertinent provisions of Section 01 66 11.

#### 1.5 SITE CONDITIONS – Reserved.

#### 1.6 MAINTENANCE – Reserved.

### PART 2 - PRODUCTS

#### 2.1 GENERAL

- A. Provide engine-generator set and factory authorized service and support from a manufacturer who shall warranty the complete engine-generator package with accessories as described herein.
  1. Third party and/or individual warranties for components and accessories of the engine-generator package do not meet this requirement of the specifications.
- B. Provide engine-generator set with direct 1:1 mechanical connection from engine output shaft to alternator shaft:
  1. Engine-generator sets that employ gear reduction between the engine and the alternator do not meet this requirement of the specifications.
- C. Acceptable manufacturers:
  1. Caterpillar: 100 North East Adams Street, Peoria, Illinois USA 61629.
  2. Cummins Power Generation: 1400 73<sup>rd</sup> Ave. NE, Minneapolis, MN USA 55432.
  3. Kohler: 444 Highland Drive, Kohler, WI 53044.
  4. MTU Onsite Energy: 100 Power Drive, Mankato, MN 56001.
  5. Or equal.

#### 2.2 ENGINE-GENERATOR RATINGS

- A. Provide standby engine-generator set for emergency duty having the following minimum ratings:
  1. Standby rating: 450 KW; 562.5 KVA.
  2. Power factor: 0.8.
  3. Frequency: 60 Hertz.
  4. Starting KVA at 25 percent transient voltage dip: 1,766 KVA.
  5. Output voltage: 480 VAC.
  6. Three phase, 4-wire, wye connected.

7. Rating based upon operating conditions at 1,000-foot elevation and 38 degree C ambient temperature.

B. Provide regulator system suitably filtered and capable of regulating the generator output to permit the starting and running of connected loads as shown on the Drawings, simultaneously with a maximum of 25 percent transient voltage dip with return to steady state in less than 2 seconds. Steady state is defined as operation with terminal voltage remaining constant within  $\pm 1/2$  of 1 percent of rated voltage.

### 2.3 ENGINE CONSTRUCTION

A. Provide heavy duty industrial type, liquid-cooled, four-cycle compression ignition engine.

B. Operates on No. 2 diesel fuel. Engines requiring premium fuels will not be accepted.

### 2.4 ENGINE ACCESSORY EQUIPMENT

A. Provide the following engine accessories in addition to manufacturer's standard equipment for each system required:

1. Isochronous electronic governor: Control engine speed to maintain a frequency regulation not exceeding  $\pm 0.25$  percent from no load to full rated load.
2. Oil drain extension through side of skid base to outside of generator enclosure.
3. Heavy duty air cleaner.
4. Fuel priming pump or self-priming fuel pump per manufacturer's standard.
5. Fuel/water separator.
6. Lubricating oil cooler.
7. Overcrank cut-out.
8. Overspeed cut-out.
9. Low oil pressure cut-out.
10. High coolant temperature cut-out.
11. Battery charging alternator.
12. Flexible fuel connections.
13. Engine coolant heater with shut-off valves, 4,000 watt, 480 volt, single phase with adjustable thermostat.
14. Manufacturer's standard vibration isolators located between engine-generator and skid base.

### 2.5 STARTING BATTERIES AND CHARGER

A. Provide starting batteries:

1. Sufficient number of heavy duty 12 volt DC lead acid type batteries as recommended by the generator set manufacturer.
2. Stranded copper battery cables and clamps.
3. Acid resistant metal battery rack.
4. Locate batteries and rack near engine starter.

- B. Provide automatic battery charger:
1. Transistor controlled battery charger for continuous taper charging.
  2. Two charge ranges, float and equalize at manufacturer recommended voltage.
  3. Automatic surge suppressors.
  4. DC ammeter and voltmeter.
  5. Fused AC input and DC output.
  6. Housing: Manufacturer's standard enclosure for wall mounting.
  7. Operate on input voltage of 120 VAC.
  8. Charger malfunction and low battery voltage alarms.

## 2.6 COOLING EQUIPMENT

- A. Unit mounted radiator:
1. Engine driven blower type fan sized to maintain safe operation at 105 degrees F maximum ambient temperature.
  2. Duct adapter flange with ductwork and flexible connection section between radiator and discharge louver frame.
  3. Total air flow restriction across the radiator not to exceed 0.5 inches W.C.
  4. Sized for 50 percent ethylene-glycol solution at 40 degrees C ambient and 1,000 feet elevation.
- B. Ethylene-glycol antifreeze with rust-inhibitor to -40 degrees C.

## 2.7 EXHAUST EQUIPMENT

- A. Silencer:
1. Provide critical grade silencer (mounted inside the generator set enclosure).
  2. Provide inlet and outlet flanges conforming to American Standard 125-150 pound drilling, along with gaskets for sizes 4-inch diameter and larger.
  3. Mount so that weight is not supported by engine.
- B. Piping:
1. Use ASTM A-53 and AP1-5L black seamless and welding pipe, ASA Schedule 40 weight and wall thickness, suitable for exhaust piping.
  2. Sized to insure that exhaust backpressure does not exceed the maximum limitations specified by the generator set manufacturer.
  3. Provide condensate drain tap, connecting nipple, and drain valve with operating handle.
  4. Provide stainless steel flexible connector.
  5. Provide suitable rain cap.
- C. Insulation:
1. Provide insulation for piping, fittings, and silencer, except expansion pieces, such that surface temperatures do not exceed 150 degrees F.

## 2.8 GENERATOR CONSTRUCTION

- A. Provide three phase, 60 Hertz, single bearing, synchronous type generator of drip-proof construction with the following requirements:
1. Extended stack as required to compensate for effects of non-linear loads (variable frequency motor controllers).
  2. Reconnectable broadrange wiring.
  3. Radio suppression meeting commercial standards.
  4. Constructed to NEMA, IEEE, and ANSI standards.
  5. Class H insulation for both stator and rotor.
    - a. Protect both stator and rotor windings with 100 percent epoxy impregnation to reduce possible fungus and/or abrasion deterioration.
  6. Voltage regulation: +/-0.5 percent steady state within 40 degree ambient temperature change from no load to full load.
  7. Provide readily accessible voltage droop, voltage level and voltage gain adjustments (minimum of  $\pm 5$  percent).
  8. Provide short-circuit current sustaining device to enable the generator to sustain 300 percent of rated current for a period of up to 10 seconds.
  9. Provide molded-case, 3-pole circuit breaker as follows:
    - a. Rated 800 amperes.
    - b. Located on generator unit.
    - c. Includes lugs for line and load connections.
    - d. Includes an isolated neutral and a copper ground bus.
    - e. Complies with Section 26 28 00.

## 2.9 ENGINE/GENERATOR CONTROLLER

- A. General:
1. Digital, open protocol, microprocessor based system.
  2. True RMS sensing, 0.5% metering.
  3. Programmable protective relaying with alarm set-points for under-voltage, over-voltage, under-frequency, over-frequency, over-current, and reverse power.
  4. Programmable load demand relay.
  5. User-friendly, quick access, keypad programming.
- B. Construction:
1. IP22, dust proof cabinet designed to withstand 20 G shock (22 G @ 18-500 Hz).
  2. Processor and associated alarm components sealed in die-cast aluminum housings.
  3. Control panel and components to meet E.M.I. Immunity IEC 801-2, IEC 801-3, IEC 801-4, and EN 5082-2.
  4. UL 508A listed.
- C. Generator mounted electronic modular control panel to include:
1. Standard generator control and monitoring:
    - a. Digital ammeter, voltmeter, and frequency meter (0.5% accuracy).



- b. Ammeter/voltmeter phase selector switch.
- c. Voltage adjust rheostat.
- 2. Standard engine controls and monitoring:
  - a. Automatic/manual start-stop control.
  - b. Engine control switch for off/reset, auto start, manual start.
  - c. Cycle cranking.
  - d. Cool-down timer.
  - e. Emergency stop pushbutton.
- 3. Safety shutdown protection and LED indicators for:
  - a. Low oil pressure.
  - b. High coolant temperature.
  - c. Over-crank.
  - d. Over-speed.
  - e. Emergency stop pushbutton.
  - f. Spare.
- 4. Digital display for:
  - a. Coolant temperature.
  - b. Oil pressure.
  - c. Service hours.
  - d. Engine RPM.
  - e. System DC volts.
  - f. System diagnostic codes.
- 5. Three (3) dry contact sets wired to terminal strip as follows:
  - a. One normally open set to indicate engine failure (closes when engine-generator fails to run).
  - b. One normally closed set for motorized damper (opens when engine-generator is running).
  - c. One normally open set for running status (closes when engine-generator is running).
- 6. Route and terminate all generator "status" signals back to HMI panel in nearby facility MCC and Utility SCADA system.
- 7. Provide automatic return to safe operating conditions (no alarms that must be reset in field) after remote or on-site testing.

## 2.10 FUEL SUPPLY EQUIPMENT

- A. Provide a UL listed dual wall subbase fuel tank assembly with closed top rupture basin located below engine-generator walk-in enclosure as follows:
  - 1. Fuel tank:
    - a. Fabricate to fit specified engine-generator enclosure.
    - b. Minimum fuel capacity: 24 hours engine running time when generator is running at maximum electrical KW rating.
    - c. Minimum of 12 gauge steel top, bottom, ends and baffles.
    - d. Minimum of 7 gauge steel support channels.
    - e. Design load capacity to support engine-generator and walk-in enclosure specified.
    - f. Structural angle supports at mounting holes for walk-in enclosure.
    - g. Engine fuel supply and return openings with tubes: ½-inch NPT minimum.

- h. Manual fill tube with lockable cap: 2-inch.
- i. Vent opening: sized per NFPA requirements.
- j. Fuel level gauge.
- k. Low fuel detection system with red warning light on engine-generator control panel and dry contacts for remote indication, powered from engine starting batteries, and activated when fuel level is at 25 percent of tank capacity.
- l. Comply with ANSI/NFPA 30.
- 2. Rupture basin:
  - a. Adequate capacity to contain fuel tank leakage.
  - b. Minimum of 12 gauge steel bottom and ends.
  - c. Structural steel floor channels with mounting holes for anchoring to concrete base.
  - d. Fuel in rupture basin leak detection system with red warning light on engine-generator control panel, powered from engine starting batteries.
- 3. Symmetrical to engine-generator walk-in enclosure footprint.
- 4. Includes conduit stub-up area with removable cover.

## 2.11 WEATHERPROOF, SOUND ATTENUATING, WALK-IN ENCLOSURE/BASE ASSEMBLY

### A. General:

- 1. The intent of this specification is to provide the owner with a "walk-in" type generator set enclosure complete in every detail and requiring no additional field modifications or assembly, except where specifically allowed by these specifications. The enclosure is to be accurately dimensioned so as to be in compliance with the National Electric Code (NEC), and the National Fire Protection Association (NFPA) for clearance of all specified items included therein, and all applicable fire codes for a structure and application of this type.

### B. Provide enclosure with the following requirements:

- 1. Formed steel (minimum thickness of 14 gauge) or sheet aluminum (minimum thickness of 0.10") construction.
- 2. Modular design and construction such that the side panels, doors, and louvers do not exceed 36" in width.
- 3. Roof strengthened in such a manner as to support the largest commercially available exhaust silencer, recommended by the engine manufacturer, from the inside on the enclosure.
- 4. 26-inch minimum walk way on either side of the generator and 36-inch minimum behind the generator.
- 5. Minimum 96-inch walk way clear height.
- 6. Vermin, snow and rain proof.

### C. Provide doors with the following requirements:

- 1. Strategically located in areas as to allow ease of maintenance on the generator set and allow good access to and visibility of instruments, controls, engine gauges, etc.
- 2. Fitted with hinges rated at 1.5 times the actual door weight.

3. Fitted with adjustable, keyed alike latches and inside emergency egress hardware.
  4. Frames equipped with drip rails for water run off and fully gasketed to form a weather-tight seal.
  5. 24-inch maximum width.
- D. Provide finish as follows:
1. Prime finished assembly with a minimum of two (2) coats of rust-inhibiting primer.
  2. Paint a minimum of two (2) final coats of industrial enamel in color selected by the Owner.
- E. Provide engine exhaust silencer as follows:
1. Provide a complete engine exhaust system installed inside the envelope of the module with all interior exposed surfaces insulated (except expansion pieces) such that surface temperatures do not exceed 150 degrees F.
  2. Provide complete exhaust system consisting of, but not limited to, the following:
    - a. Critical grade silencer.
    - b. Seamless steel flexible connection with a flanged fitting at each end of the flexible section.
    - c. Rain skirt and rain flapper as recommended by manufacturer.
- F. Provide sound attenuation to meet the following requirements:
1. Maximum 70 dBA at a distance of 23 feet in any quadrant from the package.
  2. Sound attenuation material mechanically attached to the interior surfaces of the unit walls and ceiling, except for the louvered openings.
  3. Sound attenuation material is capable of thermo-insulating the enclosure to meet the heating requirement specified elsewhere.
  4. Discharge and intake plenums as follows:
    - a. Integral 90 degree insulated radiator air discharge plenum to direct the radiator air upward.
    - b. Integral 90 degree insulated air intake plenum to draw air from the grade level.
    - c. Include a service access panel for general maintenance of the plenum area.
    - d. Openings include a galvanized wire mesh screen.
- G. Provide a Packaged Power Center as follows:
1. Mounted inside the generator enclosure where shown on the Drawings.
  2. Rated at 7.5 kVA.
  3. Includes 20 amp/2-pole primary main circuit breaker and 40 amp/2-pole secondary main breaker.
  4. Includes five (5) 1-pole branch circuit breakers rated as shown on the Drawings and empty spaces with covers for five (5) additional 1-pole branch circuit breakers.
  5. Transformer wound for 480 volt, 1-phase primary and 120/240 volt, 1-phase, 3-wire secondary.
  6. Enclosure rated NEMA-3R.

7. Acceptable manufacturers:
  - a. Eaton/Cutler-Hammer "Mini-Power Center".
  - b. Schneider Electric/Square D "Mini Power Zone".
  - c. Or equal.
  
- H. Provide housing features as follows:
  1. Provide louvers with the following requirements
    - a. All aluminum construction and designed to help prevent snow and rain infiltration.
    - b. Have sufficient free area to allow for 120% of the total engine-generator set air flow requirements.
    - c. Motorized 120 VAC intake louver, closes when energized, spring returns (fail-safe) open.
    - d. Gravity type discharge louvers sized for proper air discharge velocity from the enclosure.
  2. Provide duct assembly as follows:
    - a. Directs engine cooling air to the exterior of the module through the louver provided.
    - b. Required to carry engine cooling air only and provides unrestricted removal of module cover(s).
  3. Provide heater as follows:
    - a. Electric forced air heat, thermostatically controlled, with a minimum capability of maintaining 50 degrees F temperature within the module in an outside ambient of -20 degrees F.
    - b. Operates on 480 volts, 3-phase AC.
  
- I. Provide interior and exterior lighting fixtures as shown on the Drawings.
  1. Controlled by 3-way switches located adjacent to the entrance doors.
  
- J. Provide convenience receptacles as follows:
  1. Two (2) weather-proof, 120 VAC duplex GFCI with "in-use" type cover installed on the exterior of the enclosure.
  2. Four (4) 120 VAC duplex installed within the enclosure.
  3. Powered from the packaged power center specified elsewhere in this Section.
  
- K. Provide conduits, fittings, boxes, hangers and wires as shown on the Drawings:
  1. Comply with Sections 26 05 33, 26 05 29 and 26 05 19.
  
- L. Oil and Water Drains:
  1. All necessary fittings, hoses, shut-off valves, etc. shall be provided by the manufacturer of the weatherproof enclosure to facilitate lube oil and water drain at the exterior of the enclosure. In addition, engines equipped with crankcase breather tubes shall have this tube terminate at the exterior of the enclosure directly under the radiator air discharge louver. Additionally, isolation ball valves must be installed in each jacket water heater line to facilitate replacement of the jacket water heater without draining the engine coolant.

- M. Provide fuel supply as follows:
  - 1. No. 2 diesel fuel supplied from the integral sub-base fuel tank assembly specified elsewhere.

## 2.12 ALUMINUM STAIRS, RAILING AND LANDING PLATFORM

- A. General:
  - 1. Provide two assemblies of an aluminum stairway and platform landing to access the sound enclosure entrance doors.
  - 2. Provide adequately dimensioned stairs, railing and platform so as to be in compliance with OSHA and capable of supporting minimum concentrated loading of 1,000 pounds.
- B. Provide stairs, railing and platform with the following requirements:
  - 1. Heavy duty aluminum construction meeting OSHA Standard for Industrial Stairs.
  - 2. 4-foot wide serrated and abrasive nosed stairs with adequate number of risers to access the enclosure, with angle of stairway rise as denoted in OSHA 1910.24(e).
  - 3. 4-foot wide by 8-foot long serrated platform landing.
  - 4. Stairs to set on concrete sidewalk doweled into generator pad and resting on four foot deep concrete frost footing walls for each stair and platform support in contact with the ground.

## 2.13 REINFORCED CONCRETE GENERATOR PAD

- A. Provide reinforced concrete generator pad and granular backfill as shown on drawings and specified in related sections to allow for proper routing of conduits and other penetrations.

## PART 3 - EXECUTION

### 3.1 INSTALLATION

- A. Install engine-generator package on concrete pad in accordance with manufacturer's recommendations.
  - 1. Anchor unit to concrete pad with masonry anchors.
  - 2. Provide diesel fuel required for start-up.
  - 3. Provide full tank of diesel fuel upon satisfactory completion of start-up and testing.
  - 4. Anchor stairs and platform to concrete pier at each corner contact point with ground.
- B. Fill batteries and connect cables with suitable lugs.
- C. Mount battery charger where shown on the Drawings and connect to batteries per manufacturer's recommendations.

- D. Install exhaust system piping for neat appearance and to avoid clearance issues.
  - 1. Provide with drip pocket and drain valve.
  - 2. Size pipe as recommended by the engine manufacturer.
  - 3. Equip outlet with rainguard and stainless steel bird screen.
  - 4. Install silencer in accordance with manufacturer's recommendations.
  - 5. Insulate silencer and piping in compliance with Section 22 19 33.
- E. Install fuel supply piping with designated features and safety measures to meet installation requirements and local fire/safety codes.

### 3.2 ENGINE-GENERATOR START-UP

- A. After all engine-generator equipment has been installed, provide a portable load bank test using the services of a manufacturer's representative to perform the following:
  - 1. Connect the engine-generator set to the load bank and conduct a continuous 4-hour load test which varies the load on the generator from 10 percent to 100 percent to determine that the voltage, frequency, capacity, fuel, combustion air, cooling, and ventilation systems are adequate.
    - a. Apply 10 percent load for 15 minutes, 25 percent load for 15 minutes, 50 percent load for 15 minutes, 75 percent load for 15 minutes, and 100 percent load for 3 hours.
    - b. Apply each load increment in single steps.
    - c. Observe and record the following parameters at 15 minute intervals throughout the test: voltage, frequency, amperes, oil pressure, coolant temperature, and battery charge rate (record battery charge rate at 5 minute intervals for the first 15 minutes, then at 15 minute intervals thereafter).
  - 2. Perform an automatic transfer switch test in accordance with NFPA 110.
    - a. Provide a comprehensive demonstration to Owner of the system maintenance and operation after the load bank test.
  - 3. Perform sound level readings under load.
    - a. Use properly calibrated test instrument.
    - b. Measure sound levels at 23 feet (7 meters) from front, sides and rear surfaces of generator set enclosure.

END OF SECTION

SECTION 26 36 00  
TRANSFER SWITCHES

PART 1 - GENERAL

1.1 SUMMARY

- A. Provide transfer switches as shown on the Drawings, as specified herein, and as needed for a complete and proper installation.
- B. Related work:
  - 1. Documents affecting work under this section include, but are not limited to, General Conditions, Supplementary Conditions, and Division 01 - General Requirements of these Specifications.
- C. References:
  - 1. Reserved.

1.2 SUBMITTALS

- A. Shop Drawing Submittals:
  - 1. Electrical ratings, wiring schematics, single-line diagrams, NEMA rating, and manufacturer's detailed specifications.
- B. Operation and Maintenance Manuals – Submit operation and maintenance manuals in compliance with pertinent provisions of Section 01 78 26.
- C. Certificates and Guarantees – None Required.
- D. Lubricants – None Required.
- E. Spare Parts – Provide the following spare parts that match items furnished with the transfer switches:
  - 1. Three (3) fuses of each type and rating.
  - 2. Six (6) pilot light lamps of each type and rating.

1.3 QUALITY ASSURANCE

- A. Comply with the following requirements:
  - 1. NFPA 70 National Electric Code (NEC).
  - 2. NFPA 110 Emergency and Standby Power Systems.
  - 3. UL 1008.
  - 4. NEMA ICS10-1993 Automatic Transfer Switches.
  - 5. Local codes and ordinances.

1.4 DELIVERY, STORAGE, AND HANDLING

- A. Comply with pertinent provisions of Section 01 66 11.

1.5 SITE CONDITIONS – Reserved.

1.6 MAINTENANCE – Reserved.

PART 2 - PRODUCTS

2.1 GENERAL

A. Rating:

1. 480Y/277 volts, 3 phase, 4 wire, 60 Hertz.
2. Continuous current rating as shown on the Drawings.
3. Minimum 42,000 RMS symmetrical amperes short circuit current.

B. Provide automatic transfer switches with the following requirements:

1. Double throw contact configuration with mechanical and electrical interlocks to prevent load circuits from being connected to normal and emergency power sources simultaneously.
2. Industrial type pilot devices, relays, and time delays.
3. Front accessibility for ease of maintenance.
4. Programmable neutral switch position for motor load decay with the following requirements:
  - a. Transfer time adjustable from 0-30 seconds.
  - b. Time delay occurs for both transfer directions.
  - c. Mechanical interlock to prevent both sets of contacts from being closed at the same time.
5. Undervoltage sensing (phase to ground) for each phase of normal source as follows:
  - a. Pick-up voltage adjustable from 85 to 100 percent of nominal (set at 95 percent).
  - b. Drop-out voltage adjustable from 75 to 98 percent of nominal (set at 85 percent).
6. Frequency and voltage sensing devices to prevent transfer to the emergency source until the engine-generator has reached its rated frequency and voltage as follows:
  - a. Voltage adjustable from 85 to 100 percent of nominal (set at 90 percent).
  - b. Frequency adjustable from 90 to 100 percent of nominal (set at 95 percent).
7. Time delay for override of normal source voltage sensing adjustable from 1 to 6 seconds (set at 1 second) to delay transfer and engine start signals.
8. Time delay for retransfer to normal source adjustable from 0 to 30 minutes (set at 10 minutes) beginning when normal source voltage has been restored to 95 percent of rated voltage on all three phases.
9. Test switch to simulate a normal source failure.



10. Position indicator lights to indicate which source is connected to the load.
  11. Source available indicating lights controlled by normal and emergency source sensing circuits.
    - a. Normal Source Available: green light with engraved nameplate.
    - b. Emergency Source Available: red light with engraved nameplate.
  12. Unassigned auxiliary switch position contacts: normally open, single pole, double throw, rated 10A at 240Vac/32Vdc.
  13. Engine start contacts: one normally closed, one normally open rated 10A at 32 Vdc.
  14. Engine shutdown contacts time delay adjustable from 0 to 10 minutes (set at 5 minutes) after retransfer to normal source.
  15. Engine generator exerciser: solid state, programmable time switch as follows:
    - a. Exercise cycle selectable for weekly, bi-weekly, or calendar schedule and time of day.
    - b. Exercise period adjustable with automatic retransfer to normal source at end of period.
    - c. Integral battery operation of exerciser when normal control power is not available.
- C. Install in motor control center.
- D. Acceptable manufacturers:
  1. ASCO Power Technologies.
  2. G.E. Industrial/Zenith.

### PART 3 - EXECUTION

#### 3.1 INSTALLATION

- A. Install transfer switches in accordance with manufacturer's recommendations.

#### 3.2 FIELD QUALITY CONTROL

- A. Provide the services of a factory authorized service representative to inspect, test, and adjust the automatic transfer switches to verify proper operation.

#### 3.3 DEMONSTRATION

- A. Provide training on adjustment, operation and maintenance of the automatic transfer switches.
- B. Coordinate training with that for the engine generator equipment.

END OF SECTION

TRANSFER SWITCHES  
26 36 00-3 (140218.40)

SECTION 26 43 00

SURGE-PROTECTIVE DEVICES

PART 1 - GENERAL

1.1 SUMMARY

- A. Provide surge protection as shown on the Drawings, as specified herein, and as needed for a complete and proper installation.
- B. Related work:
  - 1. Documents affecting work under this Section include, but are not necessarily limited to, General Conditions, Supplementary Conditions, and Division 01 - General Requirements of these Specifications.
- C. References:
  - 1. Reserved.

1.2 SUBMITTALS

- A. Shop Drawing Submittals:
  - 1. Manufacturer's detailed specifications.
- B. Operation and Maintenance Manuals – None Required.
- C. Certificates and Guarantees – None Required.
- D. Lubricants – None Required.
- E. Spare Parts – None Required.

1.3 QUALITY ASSURANCE

- A. Comply with the following requirements:
  - 1. NFPA 70 National Electrical Code (NEC).
  - 2. Local codes and ordinances.

1.4 DELIVERY, STORAGE, AND HANDLING

- A. Comply with pertinent provisions of Section 01 66 11.

1.5 SITE CONDITIONS – Reserved.

1.6 MAINTENANCE – Reserved.

## PART 2 - PRODUCTS

### 2.1 SURGE PROTECTION

- A. Design surge-protective device to protect AC secondary power line from line transients and other damaging voltage spikes.
- B. Provide surge-protective device with the following requirements:
  - 1. Meets or exceeds the following standards:
    - a. ANSI/IEEE C62.41, C62.45 and C62.11.
    - b. UL 1449.
  - 2. Suitable for service entrance, Category C.
  - 3. Suitable for operation on 480Y/277 volt, 3 phase, 4 wire system, at 60 Hertz.
  - 4. Capable of repeated operations.
  - 5. Replaceable modular protection.
  - 6. Backup redundant protection.
  - 7. 200,000 amperes per phase surge current capacity.
  - 8. Monitoring of normal operation, protection event and protection reduced through indication lamps.
  - 9. Built-in disconnect switch.
- C. Acceptable manufacturers:
  - 1. MCG Electronics, Inc.
  - 2. LEA International.
  - 3. Or equal.

## PART 3 - EXECUTION

### 3.1 INSTALLATION

- A. Install surge-protective device in accordance with manufacturer's recommendations on exterior surface of motor control center.

END OF SECTION

SECTION 26 60 20  
ELECTRICAL SERVICE

PART 1 - GENERAL

1.1 SUMMARY

- A. Provide electrical service as shown on the Drawings, as specified herein, and as needed for a complete and proper installation.
- B. References:
  - 1. Reserved.

1.2 SUBMITTALS

- A. Shop Drawing Submittals – None Required.
- B. Operation and Maintenance Manuals – None Required.
- C. Certificates and Guarantees – None Required.
- D. Spare Parts – None Required.

1.3 QUALITY ASSURANCE

- A. Comply with the following requirements:
  - 1. NFPA 70 National Electrical Code (NEC).
  - 2. Local codes and ordinances.
  - 3. Utility Company providing service.

1.4 DELIVERY, STORAGE, AND HANDLING

- A. Comply with pertinent provisions of Section 01 66 11.

1.5 SITE CONDITIONS – Reserved.

1.6 MAINTENANCE – Reserved.

PART 2 - PRODUCTS

2.1 ELECTRIC POWER SERVICE

- A. Electrical service for the site: 800 ampere, 480Y/277 volt, 3 phase, 4 wire, provided by Madison Gas and Electric Company (Utility Company).

## PART 3 - EXECUTION

### 3.1 PREPARATION

- A. Coordinate upgrade of the existing electrical service to site with Utility Company and Owner/Engineer.
- B. Existing 120 volt service to temporarily be maintained during construction to provide near-continuous service to City of Madison's 911 Equipment.

### 3.2 INSTALLATION

- A. The Utility Company will provide the following:
  - 1. Removal and replacement of existing service lateral wires running from Utility Company pad mounted transformer to lugs on Owner's main circuit breaker and neutral bus as shown on the Drawings.
- B. Provide the following and all other related electrical work and miscellaneous materials for a complete installation:
  - 1. Main circuit breaker as shown on the Drawings with lugs on the breaker and existing neutral bus listed for the number and AWG size of replacement service lateral wires.
  - 2. Verification of effective service grounding and main bonding jumper.
    - a. If existing service grounding and bonding is found to be deficient, then upgrade to comply with local code and utility company requirements.

### 3.3 OWNER RESPONSIBILITY

- A. Owner will pay directly to Utility Company all Utility installation and/or excess facilities charges, if any, and monthly service charges.

END OF SECTION

## SECTION 31 16 00

### SITE PREPARATION

#### PART 1 - GENERAL

##### 1.1 SUMMARY

- A. This Section describes clearing and grubbing the site as shown on the Drawings and specified in this Section.
- B. Related work:
  - 1. Documents affecting work of this Section include, but are not necessarily limited to, General Conditions, Supplementary Conditions, and Division 01 – General Requirements of these Specifications.

##### 1.2 QUALITY ASSURANCE

- A. Use adequate numbers of skilled workmen who are thoroughly trained and experienced in the necessary crafts and who are completely familiar with the specified requirements and the methods needed for proper performance of the work of this Section.

##### 1.3 DELIVERY, STORAGE, AND HANDLING

- A. Comply with pertinent provisions of Section 01 66 11.

#### PART 2 - PRODUCTS

##### 2.1 MATERIALS

- A. Provide materials, not specifically described but required for proper completion of the work of this Section, as selected by the Contractor subject to the approval of the Engineer.

#### PART 3 - EXECUTION

##### 3.1 SURFACE CONDITIONS

- A. Examine the areas and conditions under which work of this Section will be performed. Correct conditions detrimental to timely and proper completion of the Work. Do not proceed until unsatisfactory conditions are corrected.

### 3.2 PROTECTION

- A. Protect existing utilities indicated or made known.
- B. Protect trees and shrubs, where indicated to remain, by providing a fence around the tree or shrub of sufficient distance away and of sufficient height so trees and shrubs will not be damaged in any way as part of this Work.
  - 1. Do not permit any equipment to operate within 5 feet of any trees or shrubs that are to remain or in a manner as to harm overhanging branches.
- C. Protection of persons and property:
  - 1. Barricade open depressions and holes occurring as part of this Work, and post warning lights on property adjacent to or with public access.
  - 2. Operate warning lights during hours from dusk to dawn each day and as otherwise required.
  - 3. Protect structures, utilities, sidewalks, pavements, and other facilities from damage caused by settlement, lateral movement, undermining, washout, and other hazards created by operations under this Section.
- D. Use means necessary to prevent dust becoming a nuisance to the public, to neighbors, and to other work being performed on or near the site.
- E. Maintain access to the site at all times.

### 3.3 CLEARING

- A. Tree removal:
  - 1. Cut off trees and stumps at the existing ground level. Remove stumps and roots as needed.
  - 2. Remove trees and stumps within 2 feet of the proposed structures and underground piping to a depth of not less than 12 inches below the base elevation of proposed structures or underground piping.

### 3.4 CONSERVATION OF TOPSOIL

- A. After the area has been cleared of vegetation, strip the existing topsoil in areas shown on the Drawings to be seeded or planted, and to fill planters, without contamination with subsoils.
- B. Stockpile in an area clear of new construction.
- C. Maintain the stockpile in a manner which will not obstruct the natural flow of drainage.
  - 1. Maintain stockpile free from debris and trash.
  - 2. Keep the topsoil damp to prevent dust and drying out.
  - 3. Provide silt fences around perimeters of all stockpiles.
  - 4. Provide temporary seeding of stockpiles.

5. Comply with erosion and sediment control requirements of these specifications and all permitting agencies.

### 3.5 DISPOSAL

- A. General:
  1. Remove and dispose of all debris from clearing and demolition work.
  2. Dispose away from the site in a legal manner.
  3. Do not store or accumulate debris at the job site.
- B. Do not burn debris at the site.
- C. Do not conduct any generation, transportation, or recycling of construction or demolition debris, clean or general or uncontaminated soil generated during construction, remodeling, repair, and demolition of utilities, structures, and roads that is not commingled with any waste, without the maintenance of documentation identifying the hauler, generator, place of origin of the debris or soil, the weight or volume of the debris or soil, and the location, owner, and operator of the facility where the debris or soil was transferred, disposed, recycled or treated. Maintain documentation for three years.

### 3.6 UTILITIES

- A. Coordinate with utility companies and agencies as required.
- B. Where utility cutting, capping, or plugging is required, pay Utility Company to do the work or perform such work in accordance with requirements of the utility company or governmental agency having jurisdiction.

END OF SECTION



## SECTION 31 22 22

### EARTHWORK FOR ROADS, DRIVEWAYS, AND WALKS

#### PART 1 - GENERAL

##### 1.1 SUMMARY

- A. This Section describes earthwork, including clearing, tree removal, hedge removal, excavation, embankment, compaction, and subgrade preparation for constructing roads, driveways, and sidewalks as shown on the Drawings, as specified herein, and as needed for a complete installation.
- B. Construct the work of this section in accordance with the WDOT "Standard Specifications" except as herein modified.
- C. Related work:
  - 1. Documents affecting work of this Section include, but are not necessarily limited to, General Conditions, Supplementary Conditions, and Division 01 – General Requirements of these Specifications.
  - 2. Section 32 10 00.13 "Roads, Driveways, and Walks".

##### 1.2 QUALITY ASSURANCE

- A. Use adequate numbers of skilled workmen who are thoroughly trained and experienced in the necessary crafts and who are completely familiar with the specified requirements and the methods needed for proper performance of the work of this Section.
- B. Use equipment adequate in size, capacity, and numbers to accomplish the work in a timely manner.
- C. Comply with requirements of governmental agencies having jurisdiction.

#### PART 2 - PRODUCTS

- 2.1 (As specified in Part 3)

#### PART 3 - EXECUTION

##### 3.1 GENERAL CONSTRUCTION REQUIREMENTS

- A. Strip topsoil and stockpile for use with final grading.

- B. Construct to the lines and grades as shown on the Drawings.
- C. Use excess excavated materials for embankment in areas as shown on the Drawings and as directed by the Engineer.

### 3.2 CLEARING, TREE REMOVAL, AND HEDGE REMOVAL

- A. Description:
  - 1. These items consist of the removal and disposal of all obstructions, such as fences, walls, foundations, buildings, accumulations of rubbish of whatever nature and existing structures, logs, shrubs, brush, and other vegetation; the cutting, grubbing, removal and disposal of all trees and stumps.
- B. Perform these items of work within the right of way, of excavation, and as directed by the Engineer in accordance with Section 201 of the WDOT "Standard Specifications".

### 3.3 ROADWAY EXCAVATION

- A. Description:
  - 1. Roadway excavation consists of excavation, removal and satisfactory disposal of all materials including pavement, taken from within the right of way for the construction of embankments, subgrade, sub-base, shoulders, intersections, ditches, waterways, and incidental work.
  - 2. Roadway excavation does not include excavation for structures, subgrade, or rock excavation.
- B. Perform roadway excavation in accordance with Section 205 of the WDOT "Standard Specifications".
  - 1. Terminate excavation with a full depth sawcut and provide a smooth vertical surface between the existing to be removed and the existing to remain as directed by the Engineer.

### 3.4 SPECIAL EXCAVATION

- A. Description:
  - 1. Special excavation consists of the removal and disposal of all existing structures, including all types of pavement surfaces, curbs, gutters, sidewalks, driveways, walls, foundations, and drainage structures, and the placement of all suitable excavated materials in the subgrade, or embankment, or as replacement.
  - 2. Special excavation does not include rock excavation.

- B. Comply with applicable articles of Section 204 of the WDOT "Standard Specifications".
  - 1. Terminate the existing structure with a full depth saw cut and provide a smooth vertical surface between the existing to be removed and the existing to remain as directed by the Engineer.

### 3.5 EMBANKMENT

- A. Description:
  - 1. This work consists of the construction of embankments by depositing, placing and compacting earth, stone, gravel, or other materials of acceptable quality above the existing grade.
- B. Comply with applicable articles of Section 207 of the WDOT "Standard Specifications".

### 3.6 BORROW

- A. Description:
  - 1. This work consists of obtaining embankment material from locations furnished by the Contractor or from borrow pits furnished by the Owner. It includes excavating, transporting, and placing the material for the construction of embankments, subgrade, shoulders, sub-base, intersections, approaches, entrances, and other parts of the project as shown on the Drawings and directed by the Engineer.
- B. Comply with applicable articles of Section 208 of the WDOT "Standard Specifications".

### 3.7 SUBGRADE

- A. Description:
  - 1. This work consists of preparing the subgrade including shaping and final compaction of the earth for the construction of sub-base, base, and surface course.
- B. Comply with applicable articles of Section 211 of the WDOT "Standard Specifications".
- C. Proof-roll the prepared subgrade for structural acceptance before pavement construction:
  - 1. Provide 55,000-pound load on a rubber-tired, single-unit truck.
  - 2. Drive slowly over area to be inspected.

3. Repair areas which show depressions or deflections greater than 1-inch deep.
  - a. Remove and dispose unsuitable material from failed area no more than 2 feet below proposed subgrade unless otherwise directed by Engineer.
  - b. Backfill excavation with material meeting the approval of Engineer or breaker run materials as specified in Section 311 of the WDOT "Standard Specifications".
  - c. Provide and install geotextile fabrics where directed by the Engineer.
    - (1) Comply with Section 645.2.5, Geotextile Fabric, Type SR (Subgrade Reinforcement) of the WDOT "Standard Specifications".
4. Repeat proof-roll and/or repair until approved by the Engineer.

END OF SECTION

SECTION 31 23 39

EXCAVATING, BACKFILLING, AND COMPACTING

PART 1 - GENERAL

1.1 SUMMARY

- A. Excavate, backfill, compact, and grade the site to the elevations shown on the Drawings, as specified herein, and as needed to meet the requirements of the construction shown in the Contract Documents.
- B. Related work:
  - 1. Documents affecting work of this Section include, but are not necessarily limited to, General Conditions, Supplementary Conditions, and Division 01 – General Requirements of these Specifications.

1.2 QUALITY ASSURANCE

- A. Use adequate numbers of skilled workmen who are thoroughly trained and experienced in the necessary crafts and who are completely familiar with the specified requirements and the methods needed for proper performance of the work of this Section.
- B. Use equipment adequate in size, capacity, and numbers to accomplish the work of this Section in a timely manner.
- C. Comply with requirements of governmental agencies having jurisdiction.

1.3 DELIVERY, STORAGE, AND HANDLING

- A. Comply with pertinent provisions of Section 01 66 11.

PART 2 - PRODUCTS

2.1 FILL AND EXCAVATED BACKFILL MATERIALS

- A. Provide excavated backfill materials free from organic matter, rubble, or frozen material, containing no rocks or lumps over 6 inches, and with not more than 15 percent of the rocks or lumps larger than 2 inches.
- B. Fill material is subject to the approval of the Engineer, and is that material removed from excavations or imported from off-site borrow areas, predominantly granular, non-expansive soils free from organic matter and other foreign matter.

- C. Do not permit rocks having a dimension greater than 1-inch in the upper 12 inches of fill or embankment.

## 2.2 TOPSOIL

- A. Topsoil is specified under Section 32 92 00.13 of these Specifications.
- B. Obtain topsoil from sources within the project limits, or provide imported topsoil obtained from sources outside the project limits, or from both sources.

## 2.3 STRUCTURAL BACKFILL MATERIAL

- A. Provide well graded, 100 percent crushed gravel or crushed stone aggregate free of clay, loam, dirt, calcareous or other foreign matter, conforming to the Section 210 of the WDOT—"Standard Specifications" with the following gradation:

<u>Sieve Size</u>	<u>Percent Passing</u>
3.0-inch	100%
No. 4	Not less than 25%
No. 200	Not more than 15%

## PART 3 - EXECUTION

### 3.1 SURFACE CONDITIONS

- A. Examine the areas and conditions under which work of this Section will be performed. Correct conditions detrimental to timely and proper completion of the Work. Do not proceed until unsatisfactory conditions are corrected.

### 3.2 GENERAL CONSTRUCTION REQUIREMENTS

- A. Protection of existing facilities, persons, and property:
- Unless shown to be removed, protect existing structures, conduits, active utility lines and all other facilities shown on the Drawings or otherwise made known to the Contractor. If damaged, repair or replace to a condition equal to or better than the original condition at no additional cost to the Owner.
  - Notify all persons, firms, corporations, or agencies owning or using any existing structures, conduits, or utilities which may be affected by the Work prior to the start of construction.
  - Make arrangements to locate, maintain, protect, and/or relocate facilities in order to complete the Work.
  - If existing utilities are found to interfere with the permanent facilities being constructed under this Section, immediately notify the Engineer and secure his instructions.

5. Do not proceed with permanent relocation of utilities until written instructions are received from the Engineer.
6. Barricade open holes and depressions occurring as part of the Work, and post warning lights on property adjacent to or with public access.
7. Operate warning lights during hours from dusk to dawn each day and as otherwise required.
8. Protect structures, utilities, sidewalks, pavements, and other facilities from damage caused by settlement, lateral movement, washout, and other hazards created by operations under this Section.

B. Dewatering:

1. Remove all water, including rain water, encountered during trench and substructure work to an approved location by pumps, drains, and other approved methods.
2. Keep excavations and site construction area free from water.
  - a. Whenever during construction operations any loose material is deposited in the flow line of gutters, drainage structures, or ditches such that the natural flow line of water is obstructed, remove this loose material at the close of each working day. At the conclusion of construction operations, keep all drainage structures and flow lines free from dirt and debris.

C. Use means necessary to prevent dust becoming a nuisance to the public, to neighbors, and to other work being performed on or near the site.

D. Maintain access to adjacent areas at all times.

### 3.3 EXCAVATING

A. Perform excavating of every type of material encountered within the limits of the Work to the lines, grades, and elevations indicated and specified herein.

B. Satisfactory excavated materials:

1. Transport to, and place in, fill or embankment areas within the limits of the Work.

C. Unsatisfactory excavated materials:

1. Excavate to a distance below grade as directed by the Engineer, and replace with satisfactory materials.
2. Include excavation of unsatisfactory materials, and replacement by satisfactory materials, as parts of the work of this Section.

D. Surplus materials:

1. Dispose of unsatisfactory excavated material, and surplus satisfactory excavated material, away from the site at disposal areas arranged and paid for by the Contractor.

- E. Topsoil materials:
  - 1. Strip and stockpile topsoil materials from areas to be excavated and regraded for use in final grading.
- F. Excavate and backfill in a manner and sequence that will provide proper drainage at all times.
- G. Borrow:
  - 1. Obtain material required for fill or embankment in excess of that produced within the grading limits of the Work from borrow areas selected and paid for by the Contractor and approved by the Engineer.
- H. Ditches and gutters:
  - 1. Cut accurately to the cross sections, grades, and elevations shown.
  - 2. Maintain excavations free from detrimental quantities of leaves, sticks, trash, and other debris until completion of the Work.
  - 3. Dispose of excavated materials as shown on the Drawings or directed by the Engineer; except do not, in any case, deposit materials less than 3'-0" from the edge of a ditch.
- I. Unauthorized excavation:
  - 1. Unauthorized excavation consists of removal of materials beyond indicated subgrade elevations or dimensions without specific instruction from the Engineer.
  - 2. Under footings, foundations, or retaining walls:
    - a. Fill unauthorized excavations by extending the indicated bottom elevation of the footing or base to the excavation bottom, without altering the required top elevation.
    - b. When acceptable to the Engineer, lean concrete fill may be used to bring the bottom elevation to proper position.
  - 3. Elsewhere, backfill and compact unauthorized excavations as specified for authorized excavations, unless otherwise directed by the Engineer.
- J. Stability of excavations:
  - 1. Slope sides of excavations to 1:1 or flatter, unless otherwise directed by the Engineer.
  - 2. Shore and brace where sloping is not possible because of space restrictions or stability of the materials being excavated.
  - 3. Maintain sides and slopes of excavations in a safe condition until completion of backfilling.
- K. Sheeting and bracing:
  - 1. Design, provide, and install sheeting and bracing as may be necessary for safety of personnel, protection of work, and compliance with requirements of governmental agencies having jurisdiction.
  - 2. Maintain sheeting and bracing in excavations regardless of the time period excavations will be open.



3. Remove sheeting and bracing after the excavation has been backfilled to an elevation which will prevent caving of exposed sidebanks.
4. Fill voids left by the withdrawal of sheeting with compacted sand.
5. Leave sheeting and bracing in place whenever necessary to protect adjacent facilities or property.

L. Excavating for structures:

1. Conform to elevations and dimensions shown within a tolerance of 0.10 ft, and extending a sufficient distance from footings and foundations to permit placing and removing concrete formwork, installation of services, other construction required, and for inspection.
2. In excavating for footings and foundations, take care not to disturb bottom of excavation:
  - a. Excavate by hand tools to final grade just before concrete is placed.
  - b. Trim bottoms to required lines and grades to leave solid base to receive concrete.
3. Excavate for footings and foundations only after general site excavating, filling, and grading are complete.
4. Minimum soil bearing capacity: 2500 psf or as otherwise required on the Drawings.

M. Excavating for pavements:

1. Cut surface under pavements to comply with cross sections, elevations, and grades.

N. Cold weather protection:

1. Protect excavation bottoms against freezing when atmospheric temperature is less than 35 degrees F.

### 3.4 FILLING AND BACKFILLING

A. General:

1. For each classification listed below, place acceptable soil material in layers to required subgrade elevations.
2. In excavations:
  - a. Use satisfactory excavated backfill or borrow fill materials.
3. Under concrete or bituminous pavements:
  - a. Use subbase materials as specified under Section 32 10 00.13 of these Specifications.
4. Under slabs, footings, conduits and other structures and facilities:
  - a. Use structural backfill material.

B. Backfill excavations as promptly as progress of the Work permits, but not until completion of the following:

1. Acceptance of construction below finish grade including, where applicable, dampproofing and water-proofing.

2. Inspecting, testing, approving, and recording locations of underground utilities.
  3. Removing concrete formwork.
  4. Removing shoring and bracing, and backfilling of voids with satisfactory materials.
  5. Removing trash and debris.
  6. Placement of horizontal bracing on horizontally supported walls.
- C. Ground surface preparation:
1. Remove vegetation, debris, unsatisfactory soil materials, obstructions, and deleterious matter from ground surface prior to placement of fills.
  2. Plow, strip, or break up sloped surfaces steeper than one vertical to four horizontal so that fill material will bond with existing surface.
  3. When existing ground surface has a density less than that specified under "compacting" for the particular area, break up the ground surface, pulverize, moisture condition to the optimum moisture content, and compact to required depth and percentage of maximum density.
- D. Placing and compacting:
1. Place excavated backfill and fill materials in layers not more than 12 inches in loose depth.
  2. Place structural granular material in layers not more than 6 inches in loose depth.
  3. Compact each layer to the required density for the area.
  4. Do not place backfill or fill material on surfaces that are muddy, frozen, or containing frost or ice.
  5. Place backfill and fill materials evenly adjacent to structures, to required elevations.
  6. Take care to prevent wedging action of backfill against structures by carrying the material uniformly around the structure to approximately the same elevation in each lift.
  7. Where the construction includes basement or other underground walls having structural floors over them, do not backfill such walls until the structural floors are in place and have attained sufficient strength to support the walls.
  8. Compact each layer of structural backfill material with vibratory rollers, pneumatic tampers, or other compacting equipment approved by the Engineer.

### 3.5 GRADING

- A. General:
1. Uniformly grade the areas within limits of grading under this Section, including adjacent transition areas.
  2. Smooth the finished surfaces within specified tolerance.
  3. Compact with uniform levels or slopes between points where elevations are shown on the Drawings, or between such points and existing grades.

#### EXCAVATING, BACKFILLING, AND COMPACTING

31 23 39-6 (140218.40)

- B. Grading around structures:
1. Grade areas adjacent to structures to achieve drainage away from the structures, and to prevent ponding.
  2. Finish the surfaces to be free from irregular surface changes, and:
    - a. Shape the surface of areas scheduled to be under walks to line, grade, and cross-section, with finished surface not more than 0.10 ft above or below the required subgrade elevation.
    - b. Shape the surface of areas scheduled to be under pavement to line, grade, and cross-section, with finished surface not more than 0.05 ft above or below the required subgrade elevation.

### 3.6 COMPACTING REQUIREMENTS

- A. Control soil compaction during construction to provide the minimum percentage of density specified for each area as determined according to ASTM D1557 or AASHTO T-180.
- B. Provide not less than the following maximum density of soil material compacted at optimum moisture content for the actual density of each layer of soil material in place, and as approved by the Engineer.
1. Structures:
    - a. Compact the top 8 inches of subgrade and each layer of fill material or backfill material at 95 percent of maximum density.
  2. Lawn and unpaved areas:
    - a. Compact the top 8 inches of subgrade and each layer of fill material or backfill material at 85 percent of maximum density.
    - b. Compact the upper 12 inches of filled areas, or natural soils exposed by excavating, at 85 percent of maximum density.
  3. Walks:
    - a. Compact the top 8 inches of subgrade and each layer of fill material or backfill material at 90 percent of maximum density.
  4. Pavements:
    - a. Compact the top 8 inches of subgrade and each layer of fill material or backfill material at 90 percent of maximum density.
- C. Moisture control:
1. Where subgrade or layer of soil material must be moisture-conditioned before compacting, uniformly apply water to surface of subgrade or layer of soil material to prevent free water appearing on surface during or subsequent to compacting operations.
  2. Remove and replace, or scarify and air dry, soil material that is too wet to permit compacting to the specified density.
  3. Soil material that has been removed because it is too wet to permit compacting may be stockpiled or spread and allowed to dry. Assist drying by discing, harrowing, or pulverizing.

3.7 MAINTENANCE

- A. Protection of newly graded areas:
  - 1. Protect newly graded areas from traffic and erosion, and keep free from trash and weeds.
  - 2. Repair and reestablish grades in settled, eroded, and rutted areas to the specified tolerances.
  
- B. Where completed compacted areas are disturbed by subsequent construction operations or adverse weather, scarify the surface, reshape, and compact to the required density prior to further construction.

END OF SECTION

## SECTION 31 23 79

## TRENCHING, BACKFILLING, AND COMPACTING

## PART 1 - GENERAL

## 1.1 SUMMARY

- A. Trench, backfill, and compact as specified herein and as needed for installation of underground pipelines and utilities associated with the Work.
- B. Related work:
  - 1. Documents affecting work of this Section include, but are not necessarily limited to, General Conditions, Supplementary Conditions, and Division 01 – General Requirements of these Specifications.
- C. References:
  - 1. The following detailed SPECIFICATIONS FOR TRENCHING, BACKFILLING, AND COMPACTING shall govern where they alter/or add to the requirements and specifications set forth in the STANDARD SPECIFICATIONS FOR SEWER AND WATER CONSTRUCTION IN WISCONSIN, latest edition and the WISCONSIN DEPARTMENT OF TRANSPORTATION STANDARD SPECIFICATIONS FOR HIGHWAY AND STRUCTURE CONSTRUCTION, latest edition.

## 1.2 SUBMITTALS

- A. Shop Drawing Submittals – None Required.
- B. Operation and Maintenance Manuals – None Required.
- C. Certificates and Guarantees – None Required.
- D. Lubricants – None Required.
- E. Spare Parts – None Required.

## 1.3 QUALITY ASSURANCE

- A. Use adequate numbers of skilled workmen who are thoroughly trained and experienced in the necessary crafts and who are completely familiar with the specified requirements and the methods needed for proper performance of the work of this Section.
- B. Use equipment adequate in size, capacity, and numbers to accomplish the work in a timely manner.
- C. Comply with requirements of governmental agencies having jurisdiction.

1.4 DELIVERY, STORAGE, AND HANDLING

A. Comply with pertinent provisions of Section 01 66 11.

1.5 SITE CONDITIONS – Reserved.

1.6 MAINTENANCE – Reserved.

PART 2 - PRODUCTS

2.1 GRANULAR PIPE BEDDING AND COVER MATERIALS

A. Provide well graded, washed, mixture of 100 percent crushed gravel or crushed stone aggregate free of clay, loam, dirt, calcareous or other foreign matter conforming to the "Standard Specifications for Sewer and Water Construction in Wisconsin."

1. For pipe 18 inches in diameter and smaller, use material of 3/8-inch crushed stone chips with the following gradation:

<u>Sieve Size</u>	<u>Percent Passing By Weight</u>
1/2-inch	100%
3/8-inch	90-100%
No. 8	0-15%
No. 30	0-3%

2. For water mains with polyethylene wrap, use sand consisting of durable particles ranging in size from fine to coarse in a substantially uniform combination.

- a. Acceptable alternatives: Unwashed bank-run sand, rejected concrete sand, and crushed bank-run gravel.
- b. Include approximately 6 percent of fine clay or loam particles; do not allow clay or loam lumps.
- c. Moisture content: 10 percent maximum.
- d. Gradation requirements:

<u>Sieve Size</u>	<u>Percent Passing By Weight</u>
1-inch	100%
No. 16	45-80%
Material finer than No. 200	2-10%

2.2 EXCAVATED BACKFILL MATERIALS

A. Provide soil materials free from organic matter, rubble, or frozen material, containing no rocks or lumps over 6 inches, and with not more than 15 percent of the rocks or lumps larger than 2 inches.

## 2.3 GRANULAR BACKFILL

- A. Provide either sand, pit run gravel, granular material, or excavated granular materials.

1. Sand: Well graded, free from organic matter, cohesionless, complying with the "Standard Specifications for Sewer and Water Construction in Wisconsin" with the following gradation:

<u>Sieve Size</u>	<u>Percent Passing By Weight</u>
1-inch	100%
No. 16	45-80%
Material finer than No. 200	2-10%

2. Pit run gravel: Free from organic matter, cohesionless granular material obtained from natural deposits of sand and gravel, passing 3/4-inch sieve, and not more than 15 percent passing the No. 200 sieve.

3. Granular material: Use granular materials consisting of durable particles ranging in size from fine to coarse in a substantially uniform combination complying with the "Standard Specifications for Sewer and Water Construction in Wisconsin" with the following gradation:

<u>Sieve Size</u>	<u>Percent Passing By Weight</u>
2-inch	95-100%
No. 4	35-60%
Finer than No. 200	5-15%

4. Excavated granular materials: A mixture of sand and gravel, free from organic matter, clay, loam, dirt, and other foreign material, passing the 1-1/2-inch sieve, with not more than 15 percent passing the No. 200 sieve.

5. No. 2 Crushed stone: Clean, hard, tough, durable, angular material crushed from bedrock limestone, dolomite, or granite.

- a. Gradation requirements:

<u>Sieve Size</u>	<u>Percent Passing By Weight</u>
3-inch	100%
2-1/2-inch	90-100%
2-inch	35-70%
1-1/2-inch	0-15%
3/4-inch	0-5%

## 2.4 LEAN CONCRETE MIX BACKFILL

- A. Provide lean concrete mix backfill, thoroughly mixed in a concrete mixer truck complying with the "Standard Specifications for Sewer and Water Construction in Wisconsin".

## 2.5 GEOTECHNICAL FABRIC

- A. Provide geotechnical fabric for separation of granular material and native soil in areas where trench is overexcavated to remove unsuitable materials.

1. Acceptable manufacturers:

- a. Mirafi: 160N.

- b. Synthetic Industries: 601.
- c. Amaco: 4551.

## 2.6 WATER MAIN REPAIR

- A. Repair water main or water services damaged during construction utilizing products of type and manufacturers as approved by the Owner.
- B. Pipe couplings for joining of sections of cut water main where a section of new pipe is used to replace a broken pipe.
  - 1. Acceptable manufacturers:
    - a. Dresser Style 38;
    - b. Smith-Blair CC-441;
    - c. Or equal.
- C. Repair clamps for broken or cracked pipe and sealing of existing corporation stop opening:
  - 1. Use full-circle single band all stainless steel clamps.
  - 2. Acceptable Manufacturers:
    - a. Dresser Style 360;
    - b. Smith-Blair 200 Series;
    - c. Or equal.
  - 3. Replace damaged service corporation stops by installation of full-circle single band all stainless steel clamps, with service outlet, matching manufacturer's and styles used for repair of a cracked pipe.

## 2.7 PIPE INSULATION

- A. Rigid Pipe Insulation:
  - 1. Provide extruded polystyrene sheathing conforming with ASTM C578, Type IV.
  - 2. Thickness: 2 inches.
  - 3. R-Value: 10.
  - 4. Water absorption: No greater than 0.10% by volume per ASTM C272.
  - 5. Acceptable product:
    - a. Formular Rigid Foam Insulation, Owens-Corning.
    - b. Or equal.

## PART 3 - EXECUTION

### 3.1 SURFACE CONDITIONS

- A. Examine the areas and conditions under which work of this Section will be performed. Correct conditions detrimental to timely and proper completion of the Work. Do not proceed until unsatisfactory conditions are corrected.

### 3.2



### 3.2 GENERAL CONSTRUCTION REQUIREMENTS

#### A. Protection of existing facilities:

1. Unless shown to be removed, protect existing structures, conduits, active utility lines and all other facilities shown on the Drawings or otherwise made known to the Contractor. If damaged, repair, replace, or restore to a condition equal to or better than the original condition at no additional cost to the Owner.
2. Notify all persons, firms, corporations, or agencies owning or using any existing structures, conduits, or utilities which may be affected by the Work prior to the start of construction.
3. Make arrangements to locate, maintain, protect, and/or relocate facilities in order to complete the Work.
4. Make such exploration as is necessary to determine the exact location of underground utilities.
5. Exercise care during the progress of work in the area to prevent damage to the utilities.
6. Whenever it becomes necessary to relocate underground gas mains, telephone conduit, or electrical lines, the utility company involved will make such relocation. Notify the utility company promptly.
7. Whenever it becomes necessary to relocate water or other pipes or conduits in direct conflict with the proposed pipe (exclusive of culverts) which are not shown on the Drawings, obtain the direction from the Engineer for the relocation. Compensation will be allowed only for such quantities as directed by the Engineer.
8. Do not block or obstruct sidewalks, streets, and pavements.
9. Whenever during construction operations any loose material is deposited in the flow line of gutters, drainage structures, or ditches such that the natural flow line of water is obstructed, remove this loose material at the close of each working day. At the conclusion of construction operations, keep all drainage structures and flow lines free from dirt and debris.
10. Do not obstruct accessibility of fire hydrants.
11. Maintain access to adjacent areas at all times.

#### B. Protection of Trees and Shrubs:

1. Protect trees and shrubs from damage.
2. Provide exhaust deflectors or other devices for machinery as required to prevent damage to trees and shrubs from exhaust gases.
3. Do not remove trees or shrubs unless indicated on the Drawings or authorized in the field by the Engineer.
4. Where trees which are to remain interfere with normal excavation operations, use the following procedures:
  - a. Prior to excavation, carefully remove trees with trunk diameters of less than 4 inches, shrubs, and other plantings in the way of construction.
  - b. Do not machine excavate within a distance of three trunk diameters or 12 inches (whichever is greater) of any tree, and do not cut roots over 2-inch diameter unless approved by the Engineer.

- c. Excavate by hand when closer than three tree trunk diameters or 12 inches (whichever is greater).
  - d. Tree tunneling where necessary to be determined by the Engineer.
  - e. Tie back shrubs and tree limbs to prevent loss or damage.
  - f. Prune and seal damaged limbs and branches.
  - g. Provide plank wrappers wired in place to protect tree trunks from being damaged by trench machinery, tractors, or trucks; remove protective planking as soon as practical after work in vicinity has been completed.
  - h. Remove spoil banks from around trees by hand to prevent damage to trunks by construction machinery.
5. Replace trees and shrubs which cannot be protected or are damaged during construction:
- a. Replant or replace with stock of like character, quality, variety, size, shape, color and condition upon completion of the construction.
  - b. Replace 4-inch diameter and larger trees with one 4-inch diameter size tree for each 6-inches of original tree diameter or fraction thereof.
  - c. Replace trees smaller than 4-inch diameter and shrubs with same kind and type.
  - d. As an option, replant trees smaller than 2-inch diameter or shrubs which are not damaged.
6. Remove and replace trees and shrubs which do not survive in good condition for a period of 18 months after time of planting.
- C. Work on private property:
- 1. Construct work on private property within easements obtained by the Owner as shown on the Drawings.
    - a. The Contractor will be permitted construction privileges within construction easement lines as shown on the Drawings.
    - b. Perform the work in a manner such as to minimize damage to lawns, shrubs, trees and other plantings, driveways, sidewalks, fences, outbuildings, and any other miscellaneous improvements, using proper size and type of equipment.
    - c. The Engineer has the authority to prohibit the use of any equipment which in his judgment is too large or otherwise unsuitable for the conditions of the work on private property.
  - 2. Remove and replace fences, outbuildings and other miscellaneous improvements in the way of construction to the satisfaction of the property owner.
  - 3. When working in cultivated fields or gardens, remove original topsoil to a depth of 12 inches prior to excavation, and replace the topsoil to its original depth and grade upon completion of trench backfill.
  - 4. Restore the private property to its original condition or better, free of debris, stones and excess materials.

### 3.3 TRENCHING

- A. Do not advance trench excavation more than 50 feet ahead of completed pipe installation except as approved by the Engineer.
- B. Provide and maintain sheeting, shoring, and bracing necessary for protection of the Work, adjacent property, and for the safety of personnel.
1. Remove temporary sheeting and bracing after backfilling to an elevation which will prohibit caving of exposed sidebanks.
  2. Fill voids left by the withdrawal of sheeting with compacted sand.
  3. The Engineer may direct that supports in trenches be cut off at any specific elevation to protect adjacent facilities or property. Compensation for support left in place will be negotiated.
  4. No extra payment will be made for the supports left in place without the direction of the Engineer.
  5. Do not leave supports within 4 feet of the ground or pavement surface in place without the permission of the Engineer.
- C. Provide pumping, bailing, wellpointing, and construct ditches and dikes required to dewater and drain ground water, sewage, or storm water to keep the excavation and site dry for the completion of the Work.
- D. Excavation:
1. Excavate by open cut unless otherwise indicated on the Drawings.
  2. Excavate trenches to the depths and grades necessary for the pipelines with allowances for bedding material.
    - a. Comply with the following minimum depth of cover unless otherwise noted on the Drawings:
      - Water pipelines: 6 feet
      - Sewage and sludge pressure piping: 5 feet
      - Air and gas piping: 3 feet
      - Electrical or wiring conduits and cables: 30 inches
  3. Overexcavate organic, soft, spongy, or otherwise unsuitable soils found at or below the bottom of the trench to meet firm subsoil or as directed by the Engineer.
  4. Comply with the following maximum trench widths at the top of pipelines:
 

<u>Nominal Pipe Sizes (Inches)</u>	<u>Trench Widths (Inches)</u>
12 or smaller	30
14-18	36
20-24	42
27-30	48
33 and larger	1-1/3 times pipe O.D.
  5. Where the trench width exceeds the maximum limitations, provide higher strength pipe, or embed or cradle the pipe in concrete to achieve the necessary load factor as determined by the Engineer at no additional cost to the Owner.

### 3.4 EXCAVATION FOR APPURTENANCES

- A. Excavate for manholes and similar structures to the depths as shown on the Drawings and to a distance sufficient to leave at least 12 inches clear between outer surfaces and the embankment or shoring that may be used to hold and protect the banks.
- B. Overdepth excavation beyond depths indicated on the Drawings that has not been directed will be considered unauthorized. Fill with sand, gravel, or lean concrete as directed by the Engineer, and at no additional cost to the Owner.

### 3.5 BEDDING AND COVERING OF PIPE

- A. General:
  - 1. Bedding is defined as the shaped and tamped material which supports the pipes. Covering is defined as the compacted material which protects and covers the pipes.
  - 2. Provide continuous bedding and covering for underground pipelines, except where concrete encasement, concrete cradles, boring or jacking are indicated.
- B. Pipe bedding:
  - 1. Provide compacted granular pipe bedding and covering material with a minimum thickness of 4 inches under pipe barrels and 2 inches under bells.
  - 2. Wherever the trench is overexcavated due to the removal of unsuitable material, refill the excavated area to the bottom of the pipe bedding with No. 2 crushed stone or granular material conforming to the Granular Backfill Materials gradation.
    - a. Removal and replacement of material, or unsuitable material, to a depth of one foot below the bottom of the pipe barrel is considered incidental to installation of the pipe.
  - 3. Wherever the trench is overexcavated to remove unsuitable material, install geotechnical fabric between native soil and granular material:
    - a. Install fabric to cover bottom and sides of trench to heights as follows:
      - (1) Sanitary sewer, force main, and water main: to envelope entire bedding and covering material and overlap 1 foot at the top.
      - (2) Storm sewer: to cover bedding material and from sides of trench to edge of pipe.
      - (3) Where undercut is of a depth that requires more than one piece of fabric to provide envelope, provide sewn seams between sections of fabric.
  - 4. Wherever two or more pipes or conduits are placed in the same trench or excavated area, backfill the trench with granular pipe bedding and covering material to support the uppermost pipe or conduit.
  - 5. Provide sand bedding with a minimum thickness of 3 inches under electrical and wiring conduits and cables.

- C. Pipe covering:
1. Following placement of pipe and inspection of joints, provide compacted granular pipe bedding and covering material for the full width of the trench to the following levels unless otherwise shown on the Drawings:
    - a. For pipes sizes 24-inch and smaller, except flexible thermoplastic pipe: To 4 inches above the top of the pipe.
    - b. For pipes sizes 27-inch and larger, except flexible thermoplastic pipe: To the horizontal centerline of the pipe.
    - c. For flexible thermoplastic pipes: To 12 inches above the top of the pipe.
    - d. If compacted excavated materials are used for backfilling under the pavement as indicated on the Drawings: To 12 inches above the top of the pipe for all pipe sizes.
  2. Place granular pipe bedding and covering material in uniform loose layers not exceeding 8 inches thick.
    - a. Compact each layer firmly by ramming or tamping with tools approved by the Engineer in such a manner as not to disturb or injure the pipe to yield a minimum density of 95 percent of maximum dry density as determined according to ASTM D1557 or AASHTO-T180.
  3. Where trench is widened by installation of structures or jacking pits, extend bedding and covering materials to total width of excavation.

### 3.6 TRENCH BACKFILLING AND COMPACTING

- A. General:
1. Backfill trench from the top of pipe cover to topsoil, paving subgrade, or foundation level.
  2. If trenches settle during the period of construction and within the guarantee period of the work, fill trench back to the surrounding grade, and restore the surfaces.
- B. For trench in lawns, parkways, and other improved areas not subject to vehicular traffic:
1. Backfill with excavated materials in uniform loose layer not exceeding 12 inches thick.
  2. Compact each layer of trench backfill materials to yield a minimum of 85 percent of maximum dry density as determined according to ASTM D1557 or AASHTO-T180.
- C. For trench in unimproved areas and cultivated fields:
1. Backfill with excavated materials.
  2. Provide crowned surface to compensate for settlement.
- D. For trench in streets, parking areas, driveways, sidewalks, curb and gutter, or within 2 feet of any proposed curb and gutter, sidewalk, and other paved areas:
1. Backfilling with granular backfill materials:
    - a. Place in uniform loose layer not exceeding 12 inches thick and compact with vibrating roller or equivalent.

- b. Fill the top of trenches with temporary aggregate pavement material to the depth(s) required to provide aggregate base and pavement base, binder and surface courses of the depth(s) shown in the Details in the Drawings.
2. Compacting requirements:
- a. Compact each layer of trench backfill materials to yield a minimum density of 90 percent of maximum dry density as determined according to ASTM D1557 or AASHTO T-180.
  - b. Determine the density of compacted backfill at intervals of not more than 500 feet at locations selected by the Engineer.
  - c. The Owner will provide the services of an independent testing laboratory for compaction testing of suspected areas of poor compaction. Should compaction testing confirm that additional compaction efforts/methods are necessary, Contractor shall pay for all testing services and reimburse Engineer's time for this effort.

### 3.7 BACKFILL AND BEDDING FOR APPURTENANCES

- A. Provide 3 inches of sand or granular bedding material unless otherwise shown on the Drawings.
- B. Do not backfill until new concrete has properly cured, and any required tests have been accepted.
- C. Backfill in lawns and landscaped areas with excavated materials.
- D. Backfill in pavement around manholes, catch basins, inlets, valve vaults, and other structures as directed by the Engineer with granular backfill materials.

### 3.8 FINISH GRADING

- A. General:
  - 1. Provide finish grading and filling to achieve the lines and grades.
  - 2. Slope grades to drain away from structures.
- B. Finish grading:
  - 1. Except where mounding over trenches is specified, grade smooth areas of the Work including previously grassed areas that have been disturbed, and adjacent transition areas.
  - 2. Fill and compact depressions from settlement and round tops of embankments and breaks in grade.
  - 3. Protect newly graded areas from traffic and erosion. Repair settlement or washing away that may occur prior to surface restoration and re-establish grades to the required elevations at no additional cost to the Owner.
- C. Disposal of waste excavated material:
  - 1. Remove unsuitable and surplus excavated materials not used for backfilling from the project site.

2. Do not deposit on public or private property without written permission from property owner or authorized representative of appropriate public agency.

### 3.9 PIPE INSULATION

- A. Rigid Pipe Insulation:
1. Place rigid insulation board above the pipe bedding material to the width of the trench.
  2. Place rigid insulation board to the required thickness and in the locations as shown on the Drawings.

### 3.10 ROCK EXCAVATION

- A. Rock excavation is classified as excavation requiring blasting or jack hammering to remove solid rock formations such as boulders, concrete, or solid masonry exceeding one cubic yard in volume. If encountered rock excavation will be paid for as an extra.
- B. Allowable trench width for open trench excavation:
1. For pipes up to 18 inches ID: 30 inches.
  2. For larger pipes: The outside diameter of the pipe plus 8 inches.
  3. Pipe bedding: 6 inches below the bottom of the pipe.
  4. Manholes and similar structures not requiring formwork: 1-foot outside such structures.
- C. Lay pipelines constructed in trenches in rock to the grades shown on the Drawings on a continuous bed of compacted gravel or crushed stone.
1. Dispose of excavated rock; do not use as backfill.
- D. Blasting:
1. Comply with rules and regulations of authorities having jurisdiction.
    - a. Issue signals of danger before firing a blast.
    - b. Do not blast adjacent to any portion of the completed work unless proper precautions are taken to protect the work.
    - c. Use only persons who are licensed as required by State or local regulations, and who are experienced in the techniques of blasting, to perform blasting operations.
  2. Repair or reconstruct structures, pipelines, or other property damaged by blasting operations.

### 3.11 WATER MAIN REPAIR

- A. Whenever existing water mains and water service pipes are damaged during construction, stop the pipe installation work and immediately repair the damaged portion of the existing piping.
- B. Contact the Engineer and Owner immediately to report the location and extent of the damage.

- C. Repair the water main with methods of complying with "Standards for Water and Sewer Main Construction in Wisconsin", and any additional requirements required by the Owner.
- D. Utilize only materials of repair as noted in the products section of this specification or as dictated by the Owner.
- E. Where water services have been stripped or pulled from the water main, replace the corporation stop as instructed by the Engineer and Owner, and replace the water service pipe to a point as directed by the Owner.
- F. Comply with disinfection requirements as dictated by the Owner.
- G. Do not cover the repair until work is inspected and approved by the Owner.

END OF SECTION



## SECTION 31 25 00

## SOIL EROSION AND SEDIMENT CONTROLS

## PART 1 - GENERAL

## 1.1 SUMMARY

- A. Provide soil erosion and sediment controls as shown on the Drawings, as specified herein, as required by the governmental authority, and as needed for a complete and proper installation.
- B. Related work:
  - 1. Documents affecting work of this Section include, but are not necessarily limited to, General Conditions, Supplementary Conditions, and Division 01 - General Requirements of these Specifications.
- C. Related documents:
  - 1. "Wisconsin Department of Natural Resources Storm Water Management Technical Standards" and "Conservation Practice Standards".
  - 2. Wisconsin Department of Transportation "Standard Specifications for Highway and Structure Construction", latest edition and "Erosion Control Product Acceptability List".
  - 3. City of Madison Standard Specifications for Public Works Construction Erosion Control Standards

## 1.2 QUALITY ASSURANCE

- A. Provide adequate numbers of skilled workers who are thoroughly trained and experienced in the necessary crafts and who are completely familiar with the specified requirements and methods needed for proper performance of the work of this Section.
- B. Inspect all installed soil erosion and sediment control devices on a weekly basis and after rainfall events of ½-inch or greater. Provide a weekly inspection report.

## 1.3 DELIVERY, STORAGE, AND HANDLING

- A. Comply with pertinent provisions of Section 01 66 11.

## PART 2 - PRODUCTS

### 2.1 GENERAL

- A. Provide suitable work sequencing along with temporary soil erosion and sediment controls in accordance with the requirements of the Wisconsin Department of Natural Resources and the Wisconsin Department of Transportation (WDOT) "Standard Specifications" and City of Madison Standard Specifications for Public Works Construction Erosion Control Standards to prevent any turbid run-off or particulate from reaching the street.
- B. Provide manufacturer's certification that product meets the minimum specified standard, if requested by the Engineer.

### 2.2 TEMPORARY EROSION AND SEDIMENT CONTROL SYSTEMS

- A. Rolled Erosion Control Products:
  - 1. Material: Products consisting primarily of totally encased straw or excelsior that comply with WDOT Erosion Control Product Acceptability List for Temporary Ditch Checks.
  - 2. Stakes: As recommended by manufacturer.
- B. Straw bale barrier:
  - 1. Material: Clean, weed-free straw, or similar material, from agricultural crops.
  - 2. Bales: Compacted, tightly bound with twine only, not wire.
  - 3. Bale stakes: 1/2-inch diameter steel, or 1-inch diameter wood.
    - a. Length: 4 feet minimum.
- C. Silt fence:
  - 1. Material: Comply with WDOT Standard Specification 628.
  - 2. Support posts and other hardware: Comply with WDOT Standard Specification 628.
- D. Temporary cover:
  - 1. Comply with Section 32 92 00.13 of these Specifications for purity and germination.
  - 2. Seed: Annual rye, spring oats, or wheat.
- E. Compost filter log:
  - 1. Provide compost filter logs consisting of a compost/wood chip blend material placed inside a geotextile bag, and held in place with wood support posts/stakes.
    - a. Logs shall be minimum 12" diameter, unless otherwise shown on Drawings.
  - 2. Provide compost/wood chip blend consisting of 40 - 100% weed free compost and 0-60% partially decomposed wood chips. The

- compost/wood chip blend material shall pass a 2-inch sieve with a minimum of 70% retained on a 3/8-inch sieve.
3. Provide geotextile bags consisting of a knitted material with openings of 3/8 inches to contain the compost/wood chip material, but not limiting water infiltration.
  4. Provide compost material meeting the following requirements:
    - a. Particle Size: 98 percent passing a 0.75-inch screen.
    - b. Physical Contaminants: Less than 1 percent combined glass, metal, and plastic.
    - c. Organic Matter/Ash Content: At least 40 percent organic matter and less than 60 percent ash content.
    - d. Carbon to Nitrogen Ratio: 10:1 to 20:1 C:N ratio.
    - e. pH: Between 6 and 8.
    - f. Soluble Salts: Electrical conductivity below 10 dS m<sup>-1</sup> (mmhos cm<sup>-1</sup>).
    - g. Moisture Content: Between 35 and 50 percent by weight.
    - h. Maturity: Compost shall be resistant to further decomposition and free of compounds, such as ammonia and organic acids, in concentrations toxic to plant growth.
    - i. Residual Seeds and Pathogens: Noxious seeds and pathogens shall be minimized.
    - j. Other Chemical Contaminants: Meet WDNR land application requirements for compost and mulch.
    - k. A copy of the compost test results, verifying compliance with WDNR standards for Mulching For Construction Sites, shall be provided to the Engineer with each shipment of compost.
  5. Provide support posts consisting of wood stakes with minimum dimensions of 2-inch x 2-inch, with a minimum length of 28 inches for 12-inch diameter compost filter logs.
  6. Acceptable products:
    - a. Filtrexx Silt Soxx.
    - b. Or equal.

## PART 3 - EXECUTION

### 3.1 PREPARATION

- A. Coordinate construction activities and install soil erosion and sediment controls as necessary to prevent any turbid, soil laden site runoff from reaching the street.
- B. Repair eroded or washed out areas prior to the installation of soil erosion and sediment control systems.

### 3.2 ROLLED EROSION CONTROL PRODUCTS

- A. Install straw wattles or sediment logs where shown on the Drawings and as directed by the Engineer.
  - 1. Anchor each log by driving stakes through the ends and at 2-foot intervals.
  - 2. Inspect frequently and repair or replace as necessary.
  - 3. Remove upon completion of Work or as directed by Engineer.

### 3.3 STRAW BALE BARRIER

- A. Install straw bale barriers where shown on the Drawings and as directed by the Engineer.
  - 1. Place bales at the toe of the slope or on the contour in a row with ends tightly abutting the adjacent ends.
  - 2. Embed each bale 4 inches, minimum.
  - 3. Place bales such that bindings are horizontal.
  - 4. Anchor each bale by driving two (2) stakes through the bale.
    - a. Drive the first stake in each bale towards the previously laid bale at an angle to force the bales together.
    - b. Drive stakes flush with the bale.
  - 5. Inspect bales frequently and repair or replace as necessary.
  - 6. Remove bales upon completion of Work or as directed by Engineer.

### 3.4 SILT FENCE

- A. Install silt fence where shown on the Drawings, in accordance with WDOT Standard Specification 628, and as directed by the Engineer.
  - 1. Perform maintenance as needed.
  - 2. Remove material when it reaches 1/3 of the fence height, and as directed by Engineer.
  - 3. Replace fence where it is torn or otherwise damaged.
  - 4. Retrench or replace fence that is not properly entrenched or anchored.
  - 5. Remove fence upon completion of Work, or as directed by Engineer.

### 3.5 TEMPORARY COVER

- A. Install temporary cover where shown on the Drawings, in accordance with pertinent provisions of Section 32 92 00.13 of these Specifications, particularly Article 32 92 00.13 3.4, and as directed by the Engineer.

### 3.6 COMPOST FILTER LOG

- A. Install compost filter logs at locations shown, or as indicated by notes, on Drawings.

- B. Stake compost filter logs in place with wood support posts.
  - 1. Drive wood stakes through logs with at least 12 inches of the stake in the ground and 3 inches of the stake above the filter log. Install stakes every 5 feet along each log unless conditions warrant closer spacing.
    - a. Where more than one log is needed to achieve planned lengths, ends shall be overlapped at least 12 inches with both ends staked into place.
- C. Perform maintenance as needed. Remove collected silt or sediment when silt/sediment reaches one-half the height of filter log(s).
- D. Remove compost filter logs upon completion of Work or as directed by Engineer, unless logs to be incorporated into landscape. If compost filter logs are intended to be left as a permanent filter, or part of the natural landscape, seed the logs as part of permanent seeding requirements.

END OF SECTION



SECTION 32 10 00.13

ROADS, DRIVEWAYS, AND WALKS

PART 1 - GENERAL

1.1 SUMMARY

- A. Provide roads, driveways, and walks as shown on the Drawings, as specified herein, and as needed for a complete and proper installation.
- B. Construct roads, driveways, and walks in accordance with the WDOT "Standard Specifications" and "Supplemental Specifications", except as herein modified.
- C. Related work:
  - 1. Documents affecting work of this Section include, but are not necessarily limited to, General Conditions, Supplementary Conditions, and Division 01 - General Requirements of these Specifications.

1.2 QUALITY ASSURANCE

- A. Source quality control:
  - 1. Comply with Section 106 of the WDOT "Standard Specifications".
  - 2. Submit certificates from source of aggregate materials that aggregate meets specified standards.
  - 3. Submit certificates from geotextile manufacturer that fabric meets specified standards.
  - 4. Obtain asphaltic mixtures and Portland Cement concrete from plants approved by the WDOT.
  - 5. Submit the name of the source of materials proposed for use on the Project to the Engineer at the Preconstruction Meeting.
  - 6. Submit WDOT mix designs for asphaltic surface plant mix, asphaltic concrete binder and surfaces courses, and Portland Cement concrete proposed to be constructed.
- B. Hot mix asphalt pavement quality management program:
  - 1. Comply with Section 460.2.8 of the WDOT "Standard Specifications".
- C. Concrete pavement testing and quality control:
  - 1. Provide the services of an independent testing laboratory for the following specified sampling and testing requirements:
    - a. Make beams or cylinders in accordance with Section 415 of the WDOT "Standard Specifications" and test the Portland Cement concrete pavement for flexural or compressive strength.

- b. Take cores in accordance with Section 415 of the WDOT "Standard Specifications" and determine the thickness of the Portland Cement concrete pavement.

## PART 2 - PRODUCTS

### 2.1 SUBBASE

- A. Breaker run materials:
  - 1. Use crushed stone or crushed concrete complying with Section 311 of the WDOT "Standard Specifications" for Breaker Run.

### 2.2 BASE COURSE

- A. Asphaltic base:
  - 1. Comply with Section 315 of the WDOT "Standard Specifications" for materials and material preparation.
- B. Concrete base:
  - 1. Comply with Section 320 of the WDOT "Standard Specifications" for materials and material preparation.

### 2.3 TACK COATS

- A. Asphaltic materials:
  - 1. Comply with types shown in Section 455.2.5 of the WDOT "Standard Specifications".

### 2.4 SURFACE COURSE

A.

- A. Asphaltic surface:
  - 1. Comply with Section 465 of the WDOT "Standard Specifications" Type E-0.3. Conform to the following nominal size of aggregate in the mixture:
    - a. Use 19 mm (3/4") for binder course.
    - b. Use 12.5 mm (1/2") for binder and surface course.
    - c. Use 9.5 mm (3/8") for leveling binder and surface course.
    - d. For 3-1/2" pavement: 9.5 mm: 1-1/2" surface course, 12.5 mm 2" binder course.
- B. Portland Cement concrete pavement
  - 1. Comply with Section 415 of the WDOT "Standard Specifications" for materials and material preparation.

### 2.5 CONCRETE SIDEWALK

- A. Comply with Section 602 of the WDOT "Standard Specifications".



- B. Concrete: Comply with Section 03 30 00 "CAST-IN-PLACE CONCRETE".

2.6 CONCRETE DRIVEWAYS

- A. Comply with Section 416 of the WDOT "Standard Specifications".

1.2

2.7 CONCRETE CURB AND GUTTER

- A. Comply with Section 601 of the WDOT "Standard Specifications".

2.8 GEOTECHNICAL FABRIC

- A. Comply with applicable articles of Section 645.2.2, Type SAS (Subgrade Aggregate Separation), of the WDOT "Standard Specifications".

2.9 CONCRETE CURING AGENTS

- A. Comply with Section 415.2.4 of the WDOT "Standard Specifications".

PART 3 - EXECUTION

3.1 GENERAL CONSTRUCTION REQUIREMENTS

- A. Comply with the following Sections of the WDOT "Standard Specifications" except as modified herein:
  - 1. Subbase: Section 311.
  - 2. Base courses:
    - a. Asphaltic: Section 315.
    - b. Concrete: Section 320.
  - 3. Surface Courses:
    - a. Hot Mix Asphalt Pavement: Section 460.
    - b. Asphaltic Surface: Section 465
    - c. Concrete Pavement: Section 415.
  - 4. Tack Coat: Section 455.
  - 5. Curb and gutter: Section 601.
  - 6. Concrete Sidewalks: Section 602.
  - 7. Concrete Driveways: Section 416.
  - 8. Geotechnical fabric: Section 645.
- B. Comply with the thickness and width shown on the Drawings.
  - 1. Construct elevation and crown of the finished surfaces to meet the required profile and section shown on the Drawings.
- C. Compaction test for aggregate subbase, base, and surface courses:
  - 1. Proof-roll for compaction by driving a rubber-tired, single-unit truck with a minimum 45,000 -pound load slowly over the area to be inspected.

2. Repair areas which show depressions or deflections greater than:
  - a. 3/4-inch deep for subbase.
  - b. 1/2-inch deep for base.
  - c. 1/4-inch deep for surface.
3. Repeat proof-roll and/or repair until approved by the Engineer.

### 3.2 TACK COAT

- A. Asphaltic Materials:
  1. Apply tack coat on new binder course if traffic has been allowed on it and on all existing paved surfaces to be overlaid at a minimum rate of 0.025 gallons per square yard.
  2. Do not apply when ambient temperature is less than 36 degrees F. or when local conditions indicate that rain is imminent.

### 3.3 SURFACE COURSES

- A. Asphaltic surface:
  1. A leveling binder course will be used to correct crown or other irregularities between the existing surface and the proposed surface shape.
  2. Minimum and Maximum thickness: Comply with Section 460.3.2 of the WDOT "Standard Specifications".
  3. Repair settled trenches, spalled pavement, and other defective binder before placement of asphaltic surface course.
- B. Provide asphaltic materials of a consistency to allow adequate workability around structures and joints.
- C. Acceptable tolerances for the pavement surface:
  1. Longitudinal tolerance:
    - a. Sweep the surface clean and test for smoothness when finish surface is complete.
    - b. Use a 10-foot straightedge as specified in Section 415.3.11.8 or Section 450.3.2.9 of the WDOT "Standard Specifications".
    - c. Remove and replace depressions or high points which cannot be corrected by grinding or further rolling.
    - d. Grinding high points or repairing depressions shall be done at the Contractor's expense.

### 3.4 CURB AND GUTTER

- A. Install aggregate base course under the curb and gutter, if indicated on the Drawings.
- B. Cut contraction joints as specified in Article 601.3.4 of the WDOT "Standard Specifications" on intervals not to exceed 15 feet.

- C. Construct expansion joints as shown on the Drawings and as specified in Article 601.3.6 of the WDOT "Standard Specifications" at the following locations:
  - 1. End of intersection radii.
  - 2. 3 feet on each side of drainage structures.
  - 3. A maximum of 300 feet between joints.
- D. Backfill according to pertinent provisions of the WDOT "Standard Specifications" except:
  - 1. Backfill areas to be paved with compacted dense graded base material.
- E. Construct depressed curb for wheelchair ramps and driveways at the locations designated by the Engineer. No additional compensation will be made for depressed curb at ramp or driveway locations.

### 3.5 SIDEWALKS

- A. Construction requirements:
  - 1. Construct to the lines, grades, and details as shown on the Drawings.
- B. Portland Cement concrete sidewalks:
  - 1. Erect temporary forms for placement of concrete as specified in Article 602.3.2.2 of the WDOT "Standard Specifications".
  - 2. Backfill overexcavated area with approved granular material.
  - 3. Construct in accordance with Section 602 of the WDOT "Standard Specifications".
    - a. Provide a minimum thickness of 4 inches.
    - b. If walk is constructed through the driveway, increase the minimum thickness to:
      - (1) 6-inches for Driveways
      - (2) Extend increased thickness to 5 feet beyond the edge of driveway
    - c. Install aggregate base course to the following thickness:
    - d. (1) 2 inches under sidewalks.
    - e. (2) 4 inches through driveways.

1.2

### 3.6 DRIVEWAYS

- A. Construction requirements:
  - 1. Construct to the lines, grades, and details as shown on the Drawings.
- B. Portland Cement concrete driveways:
  - 1. Backfill overexcavated area with approved granular material.
  - 2. Construct in accordance with Section 416.3.4 of the WDOT "Standard Specifications".
    - a. Provide a minimum thickness of:
      - (1) 8 inches for Driveways.

- C. Asphaltic driveways:
  - 1. Install 8-inch aggregate base course complying with applicable articles of Section 305 of the WDOT "Standard Specifications".
  - 2. Construct a minimum of 3-1/2 inch thick asphaltic surface course.

3.7 CONCRETE CURING AGENTS

- A. Comply with Section 415.2.4 of the WDOT "Standard Specifications".

3.8 EXISTING AGGREGATE BASE

- A. Scarify, grade, and shape the existing aggregate base to the required grades before constructing surface courses with minimum required thicknesses for new pavement or sidewalk in accordance with pertinent provisions of the WDOT "Standard Specifications".

END OF SECTION

SECTION 32 31 13  
FENCES AND GATES

PART 1 - GENERAL

1.1 SUMMARY

- A. Provide masonry fences, masonry pilasters, metal lattice panels, wooden fences, and wooden gates as shown on the Drawings, as specified herein, and as needed for a complete and proper installation.
- B. Related work:
  - 1. Documents affecting work of this Section include, but are not necessarily limited to, General Conditions, Supplementary Conditions, and Division 01 - General Requirements of these Specifications.
  - 2. Section 03 30 00, "Cast-In-Place-Concrete".
  - 3. Section 04 20 00, "Unit Masonry".
  - 4. Section 05 50 00, "Metal Fabrications".

1.2 SUBMITTALS

- A. Submit shop drawings and product data, including general dimensions, manufacturer's specifications, recommended installation procedures, and concrete footing details.

1.3 QUALITY ASSURANCE

- A. All components and related accessories to be a complete system as specified herein.

PART 2 - PRODUCTS

2.1 GENERAL

- A. Provide fencing, gates, pilasters and railings with overall height, dimensions and locations as shown on the Drawings.

2.2 WOOD

- A. Use western red cedar with anti-graffiti coating, with dimensions as shown on Drawings.

### 2.3 MASONRY UNITS AND BRICK

- A. Provide normal weight CMU's and brick or equal as shown on the drawings, as specified in Section 04 20 00, and to match existing brick wall on site. Owner to approve of color, size and locations prior to installation.

### 2.4 WOODEN FENCE FRAMEWORK

- A. Roll formed steel sections with 2.0 ounces of hot-dipped zinc coating conforming to ASTM A-123, or Type I steel pipe, or Type II steel pipe.
  - 1. Type I: Schedule 40 steel pipe with 2.0 ounces of hot-dipped zinc coating conforming to ASTM A-120.
  - 2. Type II: Pipe manufactured from steel conforming to ASTM A-569, cold-formed, high frequency welded, and having a minimum yield strength of 50,000 psi. External surface triple coated with 1.0 ounce  $\pm$ 0.1 ounce of zinc per square foot, 30  $\pm$ 15 micrograms of chromate per square inch and 0.5  $\pm$ 0.2 mils of clear cross linked polyurethane. Internal surface coated, after welding, with a zinc-rich based organic coating having a 91 percent zinc powder loading capable of providing galvanic protection.
- B. Line posts:
  - 1. 1-5/8-inch x 1-7/8-inch roll formed steel C-section weighing 2.28 pounds per foot, or 2-1/2-inch O.D. Type I steel pipe weighing 3.65 pounds per foot, or 2-1/2-inch O.D. Type II steel pipe weighing 3.12 pounds per foot.
- C. Terminal posts and gate posts for single swing gates or one leaf of double gates up to 6 feet leaf width:
  - 1. 3-1/2-inch x 3-1/2-inch roll formed steel section weighing 4.85 pounds per foot, or 3-inch O.D. Type I steel pipe weighing 5.79 pounds per foot, or 3-inch O.D. Type II steel pipe weighing 4.64 pounds per foot.
- D. Gate posts for single swing gates or one leaf of double gates with leaf width over 6 feet to 13 feet:
  - 1. 4-inch O.D. Type I steel pipe weighing 9.11 pounds per foot, or 3-1/2-inch O.D. Type II steel pipe weighing 5.71 pounds per foot.
- E. Gate posts for single swing gates or one leaf of double gates with leaf width over 13 feet to 18 feet:
  - 1. 6-5/8-inch O.D. Type I steel pipe weighing 18.97 pounds per foot.
- F. Gate posts for single swing gates or one leaf of double gates with leaf width over 18 feet:
  - 1. 8-5/8-inch O.D. Type I steel pipe weighing 28.55 pounds per foot.

### 2.5 WOODEN GATES

- A. Frame assembly of 2-inch O.D. Type I or Type II steel pipe with welded or steel fitted corners. Provide braces and trusses where necessary.

- B. Heavy duty hinges and positive type latching device suitable for padlocking.
- C. Heavy duty spring loaded gate wheel, suitable for outdoor use.
- D. Center plunger rod with double latch and catch, and semi-automatic outer catches for drive gates.
- E. Wood to match fence.

## 2.6 WOODEN FENCE AND GATE ACCESSORIES

- A. Pressed steel, cast iron or cast aluminum post caps to exclude moisture.
- B. Pressed steel, cast iron or cast aluminum rail and brace ends.
- C. 6-inch minimum length top rail couplings at maximum 20 feet on centers.
- D. Steel tension bars, tension bands, and brace bands.
- E. 3/8-inch steel truss rods with turnbuckles.
  - 1. End, corner, pull and gate posts braced and trussed to line posts.

## 2.7 METAL LATTICE PANELS

- A. Provide electro-forged welded galvanized steel or aluminum lattice panels as shown on the Drawings.
- B. Material: ASTM B209, Alloy 6063, Temper T-6 aluminum or ASTM A653 galvanized steel.
  - 1. Thickness: Minimum 0.125".
- C. Panel shape and size: Factory custom cut perforated sheets into panels with dimensions as shown on drawings.
- D. Perforations:
  - 1. Square: 2-inch square perforations placed in staggered pattern and providing 50% percent open area.
- E. Margins: Provide perforated panels with minimum width margins and pattern extending to perimeter. One inch minimum end margin and one inch minimum side margin.
- F. Equip panels with perimeter welded metal frames, borders, mounting holes, and attachment brackets to allow panel to be installed on top of masonry fence walls.
- G. Provide perforated metal fabricated panels with:
  - 1. Galvanized steel; Hot-dip galvanized zinc coating in accordance with ASTM A123.

2. Galvanized steel and aluminum; Electrostatically applied colored polyester powder coating heat cured to chemically bond finish to metal substrate.
  - a. Color: To be selected by Owner from manufacturer's standard range.
  
- H. Acceptable manufacturer: Ametco Manufacturing Corporation, 4326 Hamann Parkway, P.O. Box 1210, Willoughby, Ohio 44096; 800-362-1360.

### PART 3 - EXECUTION

#### 3.1 INSTALLATION

- A. Installation by experienced fence erectors.
- B. Conform to ASTM F-567.
- C. Space line posts at even intervals not exceeding 10 feet.
- D. Set all posts to a minimum depth of 48 inches in a concrete foundation.
  1. 12-inch diameter foundation for line posts.
  2. 24-inch diameter foundation for terminal posts.

END OF SECTION



SECTION 32 92 00.13

LAWNS AND GRASSES

PART 1 - GENERAL

1.1 SUMMARY

- A. Provide topsoil, seeding, sodding, and care of grass during establishment period for a complete surface restoration of lawns, parkways, and other areas disturbed as a result of the construction.
- B. Construct the work of this section in accordance with WDOT "Standard Specifications" except as herein modified.
- C. Related work:
  - 1. Documents affecting work of this Section include, but are not necessarily limited to, General Conditions, Supplementary Conditions, and Sections in Division 01 - General Requirements of these Specifications.

PART 2 - PRODUCTS

2.1 TOPSOIL

- A. Comply with the requirements of Section 625 of the WDOT "Standard Specifications" for materials and material preparation.

2.2 AGRICULTURAL LIMESTONE

- A. Comply with applicable Articles of Section 629 of the WDOT "Standard Specifications" for materials and material preparation.

2.3 FERTILIZER

- A. Comply with the requirements of Section 629 of the WDOT "Standard Specifications" for materials and material preparation.

2.4 MULCH

- A. Vegetative mulch:
  - 1. Provide vegetative mulch for seeded areas of a high-quality, air-dried straw of wheat, rye, oats, beans, or other approved straw, free from grass, broom sedge, noxious weeds, and weed seeds detrimental to growth of grass.

- B. Hydraulic mulch:
1. Provide virgin wood cellulose fibers complying with the following properties (percent by weight):
  2. Moisture content 15
  3. Organic matter, minimum 95
  4. Water holding capacity 400
  5. pH 4.3-8.5

## 2.5 SEED

- A. Provide new crop seed furnished in standard sealed containers bearing seed tags showing purity, germination, and weed seed content, free of wild onion, Canadian thistle, crab grass, and seeds of other noxious weeds, complying with the requirements of Section 630 of the WDOT "Standard Specifications".
1. Use Seed Mixture No. 10 where average loam, heavy clay or moist soils predominate.
  2. Use Seed Mixture No. 20 where light, dry, well-drained, sandy or gravelly soils predominate.
  3. Use Seed Mixture No. 30 on medians and on slopes or ditches within 15 feet of the shoulder where salt tolerant turf is desired.
  4. Use Seed Mixture No. 40 where a lawn type turf is desired.

## 2.6 SOD

- A. Provide field or nursery grown sod that is native to the locality of the Project.
- B. Provide sod that will not break, crumble or tear during handling and placing, free of stones, crab grass, noxious weeds, and other objectionable plants or substances injurious to plant growth.
- C. Provide sod having at least 1-inch of soil adhering firmly to the roots and cut in rectangular pieces with the shortest side not less than 12 inches. At the time of cutting sod, mow the grass height not less than 2 inches nor more than 4 inches.
- D. Do not use sod cut for more than 48 hours.

## PART 3 - EXECUTION

### 3.1 TOPSOIL PLACEMENT

- A. Scarify the compacted subgrade to a depth of 3 inches to receive the topsoil.
- B. Spread at least 4 inches of prepared topsoil in areas of new grading raked smooth and level.
- C. Grade flush with walks, curbs, and paving.

### 3.2 PREPARATION FOR SODDING OR SEEDING

- A. Do not start preparation until all other site and utility work and finished grading within the areas to be seeded have been completed.
- B. Till topsoil to a depth of at least 3 inches and smooth out all surface irregularities resulting therefrom. Leave area free of rocks or hard soil clods which will not pass through the tines of a standard garden rake.
- C. At least 7 days before applying fertilizer, spread lime uniformly in sufficient quantity to produce in the soil a pH of 6.5. Work lime thoroughly into topsoil to a depth of 3 inches.
- D. Apply fertilizer in accordance with the WDOT "Standard Specifications".

### 3.3 SODDING

- A. Provide sod in developed areas that were grassed prior to construction and as indicated on the Drawings. Sodding shall also be used in ditches and drainage swales and on all embankment slopes steeper than 3 to 1 unless protection is provided against erosion of seeding. At the Contractor's option, sodding may be substituted for seeding, but at no additional cost.
- B. Place sod with the edges in close contact and alternate courses staggered. Lightly tamp or roll to eliminate air pockets. On slopes 2 to 1 or steeper, stake sod with not less than 4 stakes per square yard and with at least one stake for each piece of sod. Stakes shall be driven with the flat side parallel to the slope. Do not place sod when the ground surface is frozen or when air temperature may exceed 90 degrees F. Water the sod thoroughly within 8 hours after placement and as often as necessary to become well established.
- C. In ditches, the sod shall be placed with the longer dimension perpendicular to the flow of water in the ditch. On slopes, starting at the bottom of the slope, the sod shall be placed with the longer dimension parallel to the contours of the ground.
- D. All exposed edges of sod shall be buried flush with the adjacent turf.

### 3.4 SEEDING

- A. Seed all grassed areas disturbed by construction operations and not receiving sod, and as indicated on the Drawings.
- B. Sow seed between September 1 and November 1, or in spring from time ground can be worked until May 15.
- C. Apply seed during favorable climatic conditions. Do not seed in windy weather or when soil is very wet. Sow seed at the rate specified for each seed mixture.

- D. Broadcasting seeding method:
  - 1. Sow seed with mechanical seeder in two directions at right angles to each other to achieve an even distribution of seed.
  - 2. After seeding, rake seed lightly into ground and roll with a roller weighing between 100 and 200 pounds per foot of roller width.
- E. Hydraulic seeding method:
  - 1. When seed is applied with a hydraulic seeder, apply at a rate of not less than 1,000 gallons of slurry per acre containing the proper quantity of seed specified above.
  - 2. When using a hydraulic seeder, apply the fertilizer in a separate operation.

### 3.5 MULCHING SEEDED AREAS

- A. Immediately after rolling seeded areas, apply mulch at the rate of 2 tons per acre within 24 hours after seeding. Use vegetative mulch on all seeded areas unless hydraulic seeding method is used.
- B. Apply mulch in accordance with the WDOT "Standard Specifications".

### 3.6 WATERING

- A. Immediately after placing erosion control matting or mulch, water seeded areas thoroughly with a fine mist spray. Keep soil thoroughly moist until seeds have sprouted and achieved a growth of 1-inch. For sod, immediately begin watering and continually keep moist until the sod has firmly knit itself to the topsoil.

### 3.7 PROTECTION OF WORK

- A. Protect newly seeded and sodded areas from all traffic by erecting temporary fences and signs. Protect slopes from erosion. Properly and promptly repair all damaged work when required.

### 3.8 APPLICATION OF FERTILIZER

- A. Six weeks after completion of seeding or sodding apply granular fertilizer over all areas at the rate of 2 lbs. of nitrogen nutrients per 1,000 sq.ft. of area.

### 3.9 CLEAN-UP

- A. At the time of final inspection of work, but before final acceptance, remove from seeded and sodded areas all debris, rubbish, excess materials, tools, and equipment.

3.10 MAINTENANCE

- A. Provide watering, mowing, and replanting and continue as necessary until a close healthy stand of specified grasses is established.
- B. Replace lawns not showing a close uniform stand of healthy specified grasses at the end of the guaranty period and maintain until acceptance.
- C. Prior to close out and after four weeks after final punch list creation, if lawn does not meet first class residential appearance, Owner may deduct \$500 from final payment to perform lawn repairs.

END OF SECTION



## SECTION 40 90 10

## PROCESS CONTROL SYSTEM UPGRADE FOR WATER SYSTEM FACILITIES

## PART 1 - GENERAL

## 1.1 SUMMARY

- A. Provide necessary modifications and upgrade to existing control system for water facilities as shown on the Drawings, as specified herein and as needed for a complete and proper installation.
- B. Related work:
  - 1. Documents affecting work under this Section include, but are not necessarily limited to, General Conditions, Supplementary Conditions, and Division 01 – General Requirements of these Specifications.
- C. Work under this Section includes:
  - 1. Providing and programming the following:
    - a. Supervisory Control and Data Acquisition (SCADA) System.
    - b. Instrumentation.
  - 2. Reconnecting existing antenna supports and antenna equipment.
  - 3. Reconnecting existing communication between the SCADA master station and the RTU.
  - 4. Providing calibration, commissioning and start-up of the entire control and monitoring system.
  - 5. Providing 8 hours of on-site training to the water operator(s).
  - 6. **Incorporate Owner provided Components as noted in Item 2.7.**
- D. References:
  - 1. Reserved.

## 1.2 SUBMITTALS

- A. Shop Drawing Submittals – None Required.
- B. Operation and Maintenance Manuals – None Required.
- C. Certificates and Guarantees – None Required.
- D. Spare Parts – None Required.
- E. Submit a test protocol document which is to be used to record test results demonstrating the instrumentation and control system operates as designed, a minimum of two (2) weeks prior to installation testing (commissioning). Documentation includes but is not limited to the following:
  - 1. Detailed test procedure.
  - 2. Checklists.

3. Blank forms and data to be recorded.
4. Test equipment to be used and calculated tolerance limits.

F. Submit completed test protocol document after installation testing has been completed certifying system functions as specified.

### 1.3 QUALITY ASSURANCE

A. Provide the services of Madison Water Utility's System Integrator Altronex who has the expertise to integrate the approved hardware and software with components from various manufacturers to present the Owner with a total system solution for the control and monitoring of the water system facilities.

### 1.4 DELIVERY, STORAGE, AND HANDLING

A. Comply with pertinent provisions of Section 01 66 11.

### 1.5 SITE CONDITIONS – Reserved.

### 1.6 MAINTENANCE – Reserved.

## PART 2 - PRODUCTS

### 2.1 SCADA SYSTEM

A. Upgrade and modify the existing Supervisory Control and Data Acquisition (SCADA) System to provide control, monitoring, alarming and reporting functions for the water system facilities.

1. Consult with the Owner for the following:
  - a. To determine type and layout of SCADA graphic screens representing the water system facilities process equipment.
  - b. To determine which alarms should notify operators via alarm notification software.
  - c. To determine phone list(s) and scheduling for alarm notification software.
  - d. To determine the specific format and information displayed for each report.
  - e. To determine the number of security password levels required for operations.

### 2.2 SCADA SERVER PROGRAMMING

A. Provide simple and intuitive navigation system to branch to other screens, including but not limited to the following:

1. Process overview status screen.
2. Detailed individual process status screens.
3. Control/setpoint entry screens.
4. Motor runtime/cycle screen.



5. Flow total screen.
  6. Trend screens.
  7. Communication status screens.
  8. Alarm status screen.
  9. Alarm history screen.
- B. Provide graphic screens to display the entire water system status including valve position, pumps, motors, solenoids, instruments, equipment, etc.
- C. Provide consistent color scheme to indicate equipment status.
1. Green = "On" or "Open".
  2. Background or neutral color = "Off" or "Closed".
  3. Yellow = Required to operate, but not yet running.
  4. Blink Red = unacknowledged alarm.
  5. Solid Red = acknowledged alarm.
- D. Provide consistent color scheme to distinguish between operator adjustable control setpoints and view-only value displays.
- E. Provide data entry and control parameter adjustment screens to enter alarm setpoints, control setpoints, and select control sequence parameters.
- F. Provide totalizer screens to display the following in tabular format:
1. Motor runtimes (current day, previous day, cumulative).
  2. Motor starts/stops (current day, previous day).
  3. Flow totals (current day, previous day, cumulative).
- G. Provide communication network status screen.
- H. Provide Power Management screen to display data from Power Monitors such as voltage, current, power, etc.
- I. Provide security passwords to access control and data entry screens.
- J. Indicate if data setpoints entered are out of range and do not change setpoint to new value.
- K. Configure computer screens using 3-dimensional rendering, "Reichard Software" or similar graphic symbols.
- L. Display the alarm conditions as described elsewhere in this section.

### 2.3 GENERAL ALARM INDICATION

- A. Display the alarm conditions on the following alarm screens at the SCADA Computers:
1. Alarm history screen.
  2. Alarm status screen (showing active alarms only).
  3. Pop-up alarm message window.

- B. Provide alarm indication with the following detail:
  - 1. Time alarm occurred.
  - 2. Time alarm was acknowledged.
  - 3. Time alarm cleared.
  - 4. Location and/or equipment name.
  - 5. Alarm description.

## 2.4 INTRUSION ALARM CONTROL

- A. Reactivate PLC programming to initiate an intrusion alarm if an intrusion detection device is activated.
- B. Provide graphic screen at the SCADA computer to show the following:
  - 1. Status of each sensing device (active/not active).
  - 2. Status of each arm/disarm switch.
  - 3. Status of each intrusion alarm.
- C. Provide ability to acknowledge alarm only at the SCADA computer via password protected screen.

## 2.5 PROCESS CONTROL PANELS AND HARDWARE

- A. Provide control panels in conjunction with new MCC.

## 2.6 PROCESS INSTRUMENTATION AND CONTROL

- A. Provide process instrumentation and control features in compliance with Section 40 91 10.

## 2.7 OWNER PROVIDED COMPONENTS

- A. Utilize the following existing Allen Bradley components currently in use at BPS 115, where they can be reused:
  - 1-L32E CPU
  - 2-1769-IA16 AC INPUT CARD
  - 1-1769-IQ16 24VDC SINK/SOURCE CARD
  - 1-1769-PA2 POWER SUPPLY
  - 2-1769-OW8I AC/DC OUTPUT CARD
  - 2-1769-IF8 ANALOG INPUT CARD
  - 1-1769-OF8C ANALOG OUTPUT CARD
- B. Utilize the following new Allen Bradley components where possible:

1-NEW	1769-PA4	PA4 = POWER SUPPLY
6-NEW	1769-IA16	IA16 = AC INPUT CARD
3-NEW	1769-IF8	IF8 = 8 CHANNEL ANALOG INPUT CARD
2-NEW	1769-IQ16	IQ16 = 24VDC SINK/SOURCE CARD
2-NEW	1769-ECR	ECR = RIGHT END CAP
2-NEW	1769-L32E	L32E = CPU (ENET)
5-NEW	1769-OW8	OW8 = 8 POINT RELAY OUTPUT

## PART 3 - EXECUTION

### 3.1 INSTALLATION

- A. Re-Install remote control and telemetry features with the Utility's Master SCADA system.

### 3.2 START-UP AND TESTING

- A. Start-up and testing is responsibility of system integrator.
- B. Provide calibration of all equipment and signals prior to start-up and testing.
- C. Notify Owner and Engineer two (2) days prior to on-site start-up.
- D. Perform start-up and testing in accordance with Section 01 91 58, FACILITY START-UP.
- E. In the presence of the Owner and Engineer, perform commissioning of the system after the contractor has tested the equipment and its appurtenances for proper operating condition, start-up has been performed, and Contractor feels system is ready to be placed into operation. Commissioning includes the following:
  - 1. Testing of operational control of entire system, which includes:
    - a. System interlocks and controls.
    - b. Equipment status.
    - c. Alarm functions.
    - d. Password and security functions.
  - 2. Emergency shutdown and restarting of the system.
  - 3. Provide report after testing has been completed certifying system functions as specified.
- F. Operational test after commissioning:
  - 1. The control and monitoring system is to operate without failure prior to Substantial Completion.
  - 2. Engineer and Contractor will agree to the start date for the 14-day operational test.
  - 3. Any failure in the system will require correction by the Contractor. If the failure causes shutdown of the system for more than 12 hours, the failure will be considered as a major and a new starting date for the 14-day operational test will be determined.
    - a. Submit a major malfunction report which will include details concerning the nature of the malfunction and the resulting repair action required and taken.
- G. Provide two (2) man-days of on-site non-warranty programming modification time in two trips after Substantial Completion of the Contract.

### 3.3 TRAINING

- A. Provide eight (8) hours total of on-site formal training in two trips of the Owner's operating personnel prior to substantial completion, to include, but not be limited to the following:
1. Emergency shutdown and re-start up of the system.
  2. Complete hands-on familiarization with the process control software functions, including but not limited to the following:
    - a. Location of equipment status and process value indications.
    - b. Adjustment of setpoints and equipment control parameters.
    - c. Backup equipment operation when primary sensing devices/instruments are out of service.
    - d. Security.
  3. Procedure for manual operating equipment when the SCADA computer, HMI or PLC fail or are out of service.
  4. Alarm management.
  5. Report generation.
  6. Back-up procedures.

END OF SECTION

## SECTION 40 91 10

## PROCESS INSTRUMENTATION AND CONTROL SCHEDULE

## PART 1 - GENERAL

## 1.1 SUMMARY

- A. Provide process instrumentation as shown on the Drawings, as specified herein and as needed for a complete and proper installation.
- B. Related work:
  - 1. Documents affecting work under this Section include, but are not necessarily limited to, General Conditions, and Sections in Division 01 of these Specifications.
  - 2. Comply with the requirements of Division 26 for any electrical work related to work in Division 40.
- C. Work under this Section includes:
  - 1. Providing, programming, and control aspects of process instrumentation.
  - 2. Providing calibration, commissioning and start-up of the process instrumentation.
  - 3. Providing on-site training to the water operator.
- D. References:
  - 1. Reserved.

## 1.2 SUBMITTALS

- A. Shop Drawing Submittals – None Required.
- B. Operation and Maintenance Manuals – None Required.
- C. Certificates and Guarantees – None Required.
- D. Lubricants – None Required.
- E. Spare Parts – None Required.

1.3 QUALITY ASSURANCE – Reserved.

1.4 DELIVERY, STORAGE, AND HANDLING – Reserved.

1.5 SITE CONDITIONS – Reserved.

1.6 MAINTENANCE – Reserved.

## 1.7 ENVIRONMENTAL REQUIREMENTS

- A. Conform to sections of Division 01 during and after installation of the process instrumentation.

## PART 2 - PRODUCTS

### 2.1 PROCESS INSTRUMENTATION

A. Chlorine Process Measurement

1. Provide Chlorine Process Measurement Devices to comply with Section 40 91 13.16 as follows:

Tag	General Description	Power Supply	Measuring Range mg/l	Output mAdc
CA-In	Chlorine Analyzer (Incoming)	120Vac	0/5	4/20
CA-Out	Chlorine Analyzer (Outgoing)	120Vac	0/5	4/20

2. Control and related auxiliary equipment notes:

Tag	Control Description
CA-In	Monitors chlorine levels when water enters reservoir. On/Off operation when Reservoir Altitude Valve (RAV) opens
CA-Out	Monitors chlorine levels when water leaves reservoir. On/Off operation when any booster pump (BP-1 thru BP-4) operates.
CA-Out BP	Boosts pressure from reservoir to flow through CA-Out. On/Off operation when any booster pump (BP-1 thru BP-4) operates.

3. CA-Out Booster Pump to comply with Section 22 11 23.63. Reservoir Altitude Valve to comply with Section 22 19 23.

B. Liquid Process Measurement:

1. Provide Liquid Pressure Process Measurement Devices to comply with Section 40 91 19.29 as follows:

Tag	General Description	Loop Powered	Calibration Range	Output mAdc
PT-HZ	Monitors Pressure in High Pressure Zone (PZ3)	24Vdc	0/150 psi	4/20
PT-LZ	Monitors Pressure in Low Pressure Zone (PZ6E)	24Vdc	0/60 psi	4/20
PT-RES	Monitors Pressure in adjacent 3 MG Reservoir	24Vdc	0/50 ft	4/20

## 2. Control and related auxiliary equipment notes:

Tag	Control Description
PT-HZ	Provides high pressure alarm and low pressure alarm in high pressure zone. Utilized manually by SCADA operator to adjust BP-3 and BP-4 VFD output.
PT-LZ	Provides high pressure alarm and low pressure alarm in low pressure zone. Provides BP-3 and BP-4 low pressure (20 psi) cut out (Reservoir Bypass Mode).
PT-RES	Provides reservoir level status and high level alarm and low level alarm in reservoir. Provides BP-1 thru BP-4 low pressure (3 psi) cut out (Normal Operation Mode).

## 3. Process Switches to comply with Section 40 97 96.

## C. Flow Process Measurement:

## 1. Provide flow process measurement devices to comply with Section 40 91 23.33 as follows:

Tag	General Description	Type	Power Supply	Range GPM	Output
FM-High	High Zone Flow meter	Mag	24Vdc	500/5,000	4/20mAdc
FM-Low	Low Zone Flow meter	Mag	24Vdc	500/5,000	4/20mAdc

\*Verify meter size with mechanical drawings.

## 2. Control and related auxiliary equipment notes:

Tag	Control Description
FM-High	Meters Flow; In (-) from and Out (+) of High Pressure Zone
FM-Low	Meters Flow; In (-) from and Out (+) of Low Pressure Zone

## D. Provide Process Switches to comply with Section 40 97 96 as follows:

Tag	General Description	Power Supply	Range psi	Output
PSL-N	Low Pressure (Normal Operating Mode)	120V	0 to 10	Dry Contact
PSL-B	Low Pressure (Reservoir Bypass Mode)	120V	10 to 40	Dry Contact

## 2.2 PROCESS EQUIPMENT CONTROL

## A. Booster Pumping Equipment:

## 1. Booster Pumping Equipment (Section 44 42 56.13) control notes:

Tag	Control Description
BP-1	Local/Remote operation, operation status with check valve limit switch indication, low pressure cut off switch (normal operation), lock out (bypass operation). Provide keyed (On/Off) selector switch to allow

Tag	Control Description
	pump operation to bypass controls.
BP-2	Local/Remote operation, operation status with check valve limit switch indication, low pressure cut off switch (normal operation), lock out (bypass operation). Provide keyed (On/Off) selector switch to allow pump operation to bypass controls
BP-3	Local/Remote VFD output operation, operation status with check valve limit switch indication, low pressure cut off switch (PSL-N normal operation), low pressure cut off switch (PSL-B bypass operation). Activate either BP-3 or BP-4 in generator mode with "Generator Permissible selector switch. Provide keyed (On/Off) selector switch to allow pump operation to bypass controls except Generator Permissible switch.
BP-4	Local/Remote VFD output operation, operation status with check valve limit switch indication, low pressure cut off switch (PSL-N normal operation), low pressure cut off switch (PSL-B bypass operation). Activate either BP-3 or BP-4 in generator mode with "Generator Permissible selector switch. Provide keyed (On/Off) selector switch to allow pump operation to bypass controls except Generator Permissible switch.

B. Reservoir Altitude Valve:

1. Reservoir Altitude Valve (Section 22 19 23) control notes:

Tag	Control Description
Res-AV	On/Off operation based on permissible fill level in reservoir, solenoid controlled with manually set pressure sustaining pilot (Low Pressure Zone) in series, Close/Fail to Open with either BP-1 or BP-2 operation, Close/Fail to Open in Reservoir Bypass mode.

C. High Zone/Low Zone Transfer Pressure Reducing Valve:

1. High Zone/Low Zone Transfer Pressure Reducing Valve (Section 22 19 23) control notes:

Tag	Control Description
Trans-PRV	On/Off operation based on solenoid control by remote SCADA, with manually set pressure reducing pilot (Low Pressure Zone) and manually set pressure sustaining pilot (High Pressure Zone) in series, Close/Fail to Open with either BP-3 or BP-4 operation.

D. Normal Operation/Reservoir Bypass Modes:

1. Selector Switch (Section 40 97 96) control notes:

Tag	Control Description
Normal Operating Mode - Reservoir Bypass Mode	Select between Normal Operating Mode and Reservoir Bypass Mode
Generator Permissible-BP-3 or BP-4	Select which high zone booster pump can physically be operated during a power outage.



## PART 3 - EXECUTION

### 3.1 INSTALLATION

- A. Install the process instrumentation devices in accordance with manufacturer's recommendation.
- B. Install identification tags to comply with Section 26 05 53 and as follows:
  - 1. Provide metal tags to field instruments.
  - 2. Provide engraved plastic tags at MCC equipment.
- C. Identify all wires at both ends with wire markers to comply with Section 26 05 19. Show these numbering on the as-build drawings.
- D. Ground the shield of instrumentation controls cable at one end only (control panel). Insulate the shield at the other end from the ground.
- E. Touch-up and clean enclosures after the start-up.

### 3.2 START-UP AND TESTING

- A. Start-up and testing is responsibility of equipment supplier.
- B. Provide calibration of all equipment and signals prior to start-up and testing.

### 3.3 TRAINING

- A. Provide eight (8) hour training sessions of on-site formal training of the Owner's operating personnel prior to substantial completion, to include, but not be limited to, the following:
  - 1. Complete hands-on familiarization with the process instrumentation devices functions related to the application.

END OF SECTION



SECTION 40 91 13.16

CHLORINE PROCESS MEASUREMENT DEVICES

PART 1 - GENERAL

1.1 SUMMARY

- A. Provide chlorine process measurement devices as shown on the Drawings, as specified herein, and as needed for a complete and proper installation.
- B. Related work:
  - 1. Documents affecting work under this Section include, but are not necessarily limited to, General Conditions, Supplementary Conditions, and Division 01 - General Requirements of these Specifications.
- C. References:
  - 1. Reserved.

1.2 SUBMITTALS

- A. Shop Drawing Submittals:
  - 1. Manufacturer's detailed specifications.
- B. Operation and Maintenance Manuals – Submit operation and maintenance manuals in compliance with pertinent provisions of Section 01 78 26.
- C. Certificates and Guarantees – None Required.
- D. Lubricants – None Required.
- E. Spare Parts – None Required.

1.3 QUALITY ASSURANCE – Reserved.

1.4 DELIVERY, STORAGE, AND HANDLING

- A. Comply with pertinent provisions of Section 01 66 11.

1.5 SITE CONDITIONS – Reserved.

1.6 MAINTENANCE – Reserved.

## PART 2 - PRODUCTS

### 2.1 CHLORINE ANALYZERS

- A. Provide chlorine analyzers to monitor free or total chlorine residuals with the following features:
1. Utilizes colorimetric DPD or amperometric measurement technology.
  2. In-enclosure chemical storage for 30 days unattended testing.
  3. Range of 0-5 mg/l.
  4. Accuracy: +/- 5% or 0.035 mg/l, whichever is greater.
  5. Precision: +/- 5% or 0.005 mg/l, whichever is greater.
  6. Output: 4-20 mAdc.
  7. Cycle time: 2.5 minutes.
  8. IP-62 or NEMA 4X enclosure with programming keypad.
  9. Capable of changing from free residual to total residual by changing chemicals.
  10. Automatic, self-testing diagnostics.
  11. Power: 120 Vac, 60 Hz.
  12. Acceptable for continuous chlorine monitoring.
  13. Accessories:
    - a. Maintenance Kit: including replaceable parts for one-year.
    - b. Supply of chemicals for one-year.
    - c. Sample inlet flowmeter, rate control valve, and pressure reducing valve to limit outlet pressure to within 0.5 psi.
  14. Acceptable manufacturers:
    - a. Hach, Model CL17.
    - b. Or approved equal.
- B. Schedule:
1. Provide two chlorine analyzers. One measuring chlorine into reservoir (CA-in) and one measuring chlorine out of the reservoir (CA-out).

## PART 3 - EXECUTION

### 3.1 INSTALLATION

- A. Install equipment in accordance with the manufacturer's recommendations.
- B. Coordinate power supply for non-continuous remote operation.
- C. Coordinate transfer or output signal to SCADA.

### 3.2 CALIBRATION

- A. Calibrate and program equipment to meet system requirements.

3.3 START-UP AND TESTING

- A. Comply with the manufacturer's recommended testing procedures.

END OF SECTION



SECTION 40 91 19.29

LIQUID PRESSURE PROCESS MEASUREMENT DEVICES

PART 1 - GENERAL

1.1 SUMMARY

- A. Provide liquid pressure process measurement devices as shown on the Drawings, as specified herein, and as needed for a complete and proper installation.
- B. Related work:
  - 1. Documents affecting work of this Section include, but are not necessarily limited to, General Conditions, Supplementary Conditions, and Division 01 - General Requirements of these Specifications.
- C. References:
  - 1. Reserved.

1.2 SUBMITTALS

- A. Shop Drawing Submittals:
  - 1. Manufacturer's detailed specifications.
- B. Operation and Maintenance Manuals: Submit operation and maintenance manuals in compliance with pertinent provisions of Section 01 78 26.
- C. Certificates and Guarantees – None Required.
- D. Lubricants – None Required.
- E. Spare Parts – None Required.

1.3 QUALITY ASSURANCE – Reserved.

1.4 DELIVERY, STORAGE, AND HANDLING

- A. Comply with pertinent provisions of Section 01 66 11.

1.5 SITE CONDITIONS – Reserved.

1.6 MAINTENANCE – Reserved.

PART 2 - PRODUCTS

2.1 PRESSURE INDICATOR TRANSMITTER

- A. Design pressure/level indicator transmitter to sense and transmit water pressure/level.

- B. Provide pressure transmitter with the following requirements:
1. Transducer to be an integrated circuit sensor type with true gauge pressure reading by venting of reference side of sensor to atmosphere.
  2. Primary fill-fluid: Silicone 200.
  3. Diaphragm material: 316 stainless steel.
  4. Process Connection: 1/2" NPT.
  5. Mounting bracket: 1-1/4" to 2" pipe or surface mounting as required.
  6. Integral indicator: Local indicator with minimum 3-1/2 digit LCD meter.
  7. Damping: Adjustable up to 15 seconds minimum.
  8. Adjustment: Integral zero and span adjustments.
  9. Power Supply: Loop power 24 Vdc.
  10. Output: 4-20 mAdc.
  11. Transient protection as required.
  12. Block and bleed manifold.
  13. Enclosure: NEMA 4X.
- C. Provide remote diaphragm seals with the following requirements:
1. Fluid: Silicone 200.
  2. Diaphragm size: 4-inch, 316 stainless steel.
  3. Capillary: 316 stainless steel armor capillary.
- D. Provide pressure sensor isolator ring as required to comply with Section 40 97 96.
- E. Acceptable manufacturers:
1. Rosemount, Model IGP10-A22D1F.
  2. Or Approved equal.

### PART 3 - EXECUTION

#### 3.1 INSTALLATION

- A. Install equipment in accordance with manufacturer's recommendations.

#### 3.2 CALIBRATION

- A. Calibrate and program equipment to meet system requirements.

#### 3.3 START-UP AND TESTING

- A. Comply with the manufacturer's recommended testing procedures.

END OF SECTION



SECTION 40 91 23.33

FLOW PROCESS MEASUREMENT DEVICES

PART 1 - GENERAL

1.1 SUMMARY

- A. Provide flow process measurement devices as shown on the Drawings, as specified herein, and as needed for a complete and proper installation.
- B. Magnetic Flow Meters and cabling from transmitter to flow indicator noted as shaded in the PRODUCTS section of this specification will be provided by MWU. MWU will deliver the mag meters and cabling to Booster Pumping Station 115 for installation by the Installation Contractor. **Shaded product information noted in this specification is for the Installation Contractor information only.**
- C. References:
  - 1. Reserved.

1.2 SUBMITTALS

- A. Shop Drawing Submittals:
  - 1. Manufacturer's detailed specifications.
- B. Operation and Maintenance Manuals: Submit operation and maintenance manuals in compliance with pertinent provisions of Section 01 78 26.
- C. Certificates and Guarantees – None Required.
- D. Lubricants – None Required.
- E. Spare Parts – None Required.

1.3 QUALITY ASSURANCE

- A. All flow process measurement device of the same type to be provided by one manufacturer.

1.4 DELIVERY, STORAGE, AND HANDLING

- A. Comply with pertinent provisions of Section 01 66 11.

1.5 SITE CONDITIONS – Reserved.

1.6 MAINTENANCE – Reserved.

## PART 2 - PRODUCTS

## 2.1. ELECTROMAGNETIC FLOW METERS

- A. Provide electromagnetic, micro-processor based flow meters and detector with a remote mounted converter meeting the following requirements:
1. Transmitter:
    - a. Power supply: 120 VAC as shown on the Drawings.
    - b. Output: Isolated 4-20 mA dc and pulse configurable for set volume per pulse.
    - c. Display: Alphanumeric LCD displaying flow rate and totalized flow.
    - d. Adjustment: Field programmable by keypad entry.
    - e. Operating temperature: -4 to 120 degrees F.
    - f. Enclosure: NEMA 4X.
    - g. Mounting: Remotely mounted as shown on the Drawings.
    - h. Utilizes high impedance circuitry.
  2. Transducer:
    - a. Design: Permanent submergence Pulsed DC Magnetic type, measures bi-directional flow, and automatic adjustment of sensitivity to match flow velocities.
    - b. Submersible cable(s) factory-sealed at the transducer and routed continuously without splices to transmitter for remote-mounted transmitters.
    - c. Flow range: 1 fps to 30 fps.
    - d. Ambient temperature: -4 to 120 degrees F.
    - e. Tube: Min. carbon steel, 150# ANSI steel flanges and connections.
    - f. Liner: Per manufacturer's recommendations for application.
    - g. Electrodes: 316 stainless steel.
      - (1) Provide removable or electrode cleaning system in applications where electrodes may be coated and require periodic cleaning.
    - h. Submergence protection: NEMA6P or IP68.
    - i. Sealed, welded housing with separate electrode compartment.
  3. Provide the following accessories:
    - a. NEMA 4X Instrument Enclosure in compliance with Section 40-95.15 for transmitter mounting when mounted outside as shown on the Drawings.
    - b. AC power line noise filter and voltage surge protector as required.
    - c. Two (2) 316 stainless steel lining protectors or grounding rings, or grounding electrode.
    - d. Cabling from transmitter to wall mounted indicator.
    - e. Cleaning unit as required if non-removable electrodes are provided.
  4. Acceptable manufacturers:
    - a. Toshiba LF654 with LF622F.
    - b. No substitutions.

## PART 3 - EXECUTION

### 3.1 INSTALLATION

- A. Install flow process measurement devices in accordance with manufacturer's recommendations.
- B. Remote readout shall be installed on wall above trench grating. Location to be approved in field.
- C. Install conduit and wiring for power supply and signal transfer as noted on Drawings.

3.2

### 3.3 CALIBRATION

- A. Calibrate and program equipment to meet system requirements and within 1% of actual field testing.

### 3.4 START-UP AND TESTING

- A. Test accuracy in field with new orifice pipe at least 6 feet long and of suitable size to provide at least 48 inches of back pressure or alternative and approved field testing device. Connect orifice pipe or test equipment to hose from fire hydrant and discharge in street.
- B. Comply with other pertinent manufacturer's testing procedures.

END OF SECTION



SECTION 40 91 23.36

LEVEL PROCESS MEASUREMENT DEVICES

PART 1 - GENERAL

1.1 SUMMARY

- A. Provide level process measurement devices as shown on the Drawings, as specified herein. Final installation to be performed by Others at a later date when reservoir is painted in 2016.
- B. References:
  - 1. Reserved.

1.2 SUBMITTALS

- A. Shop Drawing Submittals:
  - 1. Manufacturer's detailed specifications.
- B. Operation and Maintenance Manuals: Submit operation and maintenance manuals in compliance with pertinent provisions of Section 01 78 26.
- C. Certificates and Guarantees – None Required.
- D. Lubricants – None Required.
- E. Spare Parts – None Required.

1.3 QUALITY ASSURANCE – Reserved.

1.4 DELIVERY, STORAGE, AND HANDLING

- A. Comply with pertinent provisions of Section 01 66 11.

1.5 SITE CONDITIONS – Reserved.

1.6 MAINTENANCE – Reserved.

PART 2 - PRODUCTS

2.1 SUBMERSIBLE HYDROSTATIC LEVEL TRANSMITTER

- A. The liquid level of the reservoir shall be sensed by a submersible level transducer. The transducer shall be a **Bulletin A1000, Model 157GSCI**, condensation-protective as manufactured by **Siemens/US Filter, or equal**. The transducer shall be of the head-pressure sensing type, suitable for continuous submergence and operation

and shall be installed in accordance with manufacturer's instructions. The bottom diaphragm face of the sensor shall be installed 6 inches above the floor. The sensor shall be mounted using a 316 stainless steel cable and weight system; location to be determined in the field.

- B. The transducer shall sense water level (pressure) variations and transform these variations directly into a standard process signal of 1 to 5 volts DC or 4-20 mA over the desired level range (span). The transducer shall be completely solid state, with no mechanical linkages or moving parts. Supply voltage shall be as required by Contractor.
- C. The transducer shall incorporate a variable-capacitance transducer element to convert the sensed pressure to a corresponding electrical value. The sensed media shall exert its pressure against a ceramic diaphragm that flexes minutely so as to vary its proximity to a ceramic substrate to vary the capacitance of an electrical field created between the two surfaces. A stable, hybrid, operational amplifier assembly shall be incorporated in the transducer to excite and demodulate the sensing mechanism. The transducer shall incorporate laser-trimmed, temperature compensation, and high quality components and construction to provide a precise, reliable, stable output signal directly proportional to the sensed pressure over a factory-calibrated range.
- D. The transducer shall include easily accessible offset and span adjustments. Span shall be adjustable from 100% down to 15% of the sensor range. Fine and coarse adjustments for both span and offset shall be provided using 25-turn potentiometers. Offset and span adjustments shall be non-interactive for ease of calibration. Operating pressure range of the transducer shall be between 0 to 15 psig.
- E. Submersible level transmitter shall be mounted on a stainless steel cable with PVC covered anchor as required. per manufacturer's instructions. All mounting hardware shall be stainless steel and provided with floats.

## 2.2 FLOAT SWITCHES

- A. Float switches when specified herein, shown on the drawings, or necessary to complete an operating system shall be as follows:
  - 1. The float switches shall be mercury free and consist of a 316 stainless steel housing 5½-inch diameter, stainless steel mounting clamp, a flexible two-conductor cable with a CPE jacket, and a potted SPST magnetic reed switch. Provide switch configuration (NO or NC) as required. The electrical load for the switch contacts shall be 100 VA at up to 250 volts. Float switches shall include a two-conductor cable 16 AWG with fine strands made for heavy flexing service and underwater use. Cable length shall provide for a continuous run to the terminating control panel where possible. A green grounding wire shall connect internally to the float housing. Floats shall be **Siemens Model 9G-EF, or equal.**
  - 2. Weight and buoyancy shall be such that contaminants will not result in the float switch changing operating level more than 1-inch.
  - 3. Operating temperature range shall be -31° to 194°F.

4. Provide four floats for insertion in reservoir with depth of up to 45 feet below top of hatch with water level of 42.5 feet. Floats shall sense 4 independent depths and controls as follows:
  - a. Overflow High Water Level (Alarm and locks out well pump).
  - b. Normal High Water Level (Shuts off well pump).
  - c. Normal Low Water Level (Turns on well pump).
  - d. Emergency Low Water Level (Alarm and locks out booster pumps).
- B. Floats shall be provided with stainless steel cable with PVC covered anchor per manufacturer's instructions. All mounting hardware shall be stainless steel and provided with floats for installation by Others in 2016. Mounting location to be at reservoir access hatch located above reservoir pilaster and ladder.
- C. Provide stainless steel kellum grips for each float cable.

### PART 3 - EXECUTION

#### 3.1 INSTALLATION

- A. Provide separate power and control cabling to transducer and control through new conduits as shown on Drawings. Route cables from pilaster dog house through reservoir pilaster to top of reservoir. Provide junction boxes for control and power wiring at top of pilaster above water level for future penetrations of reservoir roof inside pilaster and final installation to reservoir roof hatch by Others in 2016.
- B. Install equipment in accordance with manufacturer's recommendations.

#### 3.2 CALIBRATION

- A. Calibrate and program equipment to meet system requirements.
- B. Integrate into control system to provide noted system control.

#### 3.3 START-UP AND TESTING

- A. Comply with the manufacturer's recommended testing procedures.

END OF SECTION





SECTION 40 94 27

DISTRIBUTED INPUT/OUTPUT (DIO) DEVICES

PART 1 - GENERAL

1.1 SUMMARY

- A. When existing devices specified in Section 40 90 10 (2.7) cannot be re-used: Provide distributed input/output (DIO) devices as shown on the Drawings, as specified herein, and as needed for a complete and proper installation.
- B. Related work:
  - 1. Documents affecting work of this Section include, but are not necessarily limited to, General Conditions, Supplementary Conditions, and Division 01 - General Requirements of these Specifications.
- C. References:
  - 1. Reserved.

1.2 SUBMITTALS

- A. Shop Drawing Submittals:
  - 1. Manufacturer's detailed specifications.
- B. Operation and Maintenance Manuals: Submit operation and maintenance manuals in compliance with pertinent provisions of Section 01 78 26.
- C. Certificates and Guarantees - Reserved.
- D. Spare Parts:
  - 1. Provide one spare module for each unique module supplied, including power supply, I/O module, and adapter.

1.3 QUALITY ASSURANCE

- A. Provide all equipment by one manufacturer.

1.4 DELIVERY, STORAGE, AND HANDLING

- A. Comply with pertinent provisions of Section 01 66 11.

1.5 SITE CONDITIONS – Reserved.

1.6 MAINTENANCE – Reserved.

## 1.7 ENVIRONMENTAL REQUIREMENTS

- A. Maintain area free of dirt and dust during and after installation of products.

## PART 2 - PRODUCTS

### 2.1 GENERAL

- A. Design distributed I/O devices to accept input contact and analog signals, perform the functions through remote Programmable Logic Controller (PLC), and output contact and analog signals to control and/or indicate the specified process.
- B. Provide modular distributed I/O system consisting of adapter, terminal base and I/O modules.
- C. Provide stand-alone distributed I/O devices for installation in Motor Control Centers and/or Variable Frequency Drives.

### 2.2 MODULAR DISTRIBUTED I/O DEVICES

- A. Provide adapter module to power the internal logic of up to eight I/O modules and communicate with the PLC via one of following networks as shown on the Drawings:
  - 1. DeviceNet.
  - 2. ControlNet.
  - 3. Ethernet/IP.
  - 4. Remote I/O.
- B. Provide terminal base for termination of field wiring to the I/O module.
- C. Provide 120VAC or 24VDC discrete input module with 8 or 16 photo-optically isolated inputs.
- D. Provide discrete output module with the following requirements:
  - 1. Minimum 8 relay type output points with each relay contact rated at 2.0A continuous, 120 VAC.
  - 2. Provide surge suppression components across each output device, per manufacturer's recommendation.
- E. Provide analog input module with a minimum of 4 input channels selectable for a 4-20 mA<sub>dc</sub> current input, with current input impedance of 160 ohms per channel.
- F. Provide analog output module with a minimum of 4 output channels selectable for a 4-20 mA<sub>dc</sub> current output and load of 500 ohms.
- G. Provide 24VDC power supply to power adapter modules as required.

- H. Provide SCANport module to interface to related SCANport devices.
- I. Acceptable manufacturers:
  - 1. Allen Bradley Flex I/O.
  - 2. Or equal.

### 2.3 STAND-ALONE DISTRIBUTED I/O DEVICES

- A. Provide DeviceNet System Accessory (DSA) module with following requirements.
  - 1. Inputs: Minimum two, 24 Vdc.
  - 2. Outputs: Minimum one relay, rated at 250V.
  - 3. Acceptable manufacturers:
    - a. Allen-Bradley.
    - b. Or equal.
- B. Provide SCANport to DeviceNet communication module to function as a gateway between DeviceNet and SCANport devices while providing discrete inputs.
  - 1. Acceptable manufacturers:
    - a. Allen-Bradley, 2100-GK61.
    - b. Or equal.

## PART 3 - EXECUTION

### 3.1 INSTALLATION

- A. Install distributed I/O devices in accordance with manufacturer recommendations.
- B. Install component identification and wire tags on all wiring.

### 3.2 START-UP AND TESTING

- A. Comply with the manufacturer's recommended procedures.

### 3.3 CLEANING

- A. Clean units as recommended by manufacturer.

END OF SECTION



SECTION 40 94 33

HUMAN-MACHINE INTERFACES

PART 1 - GENERAL

1.1 SUMMARY

- A. Provide human-machine interfaces (HMI) as shown on the Drawings, as specified herein, and as needed for a complete and proper installation.
- B. Related work:
  - 1. Documents affecting work under this Section include, but are not necessarily limited to, General Conditions, Supplementary Conditions, and Division 01 - General Requirements of these Specifications.
- C. References:
  - 1. Reserved.

1.2 SUBMITTALS

- A. Shop Drawing Submittals:
  - 1. Manufacturer's detailed specifications.
- B. Operation and Maintenance Manuals: Submit operation and maintenance manuals in compliance with pertinent provisions of Section 01 78 26.
- C. Certificates and Guarantees – None Required.
- D. Spare Parts – None Required.

1.3 QUALITY ASSURANCE

- A. All equipment to be provided by one manufacturer.

1.4 DELIVERY, STORAGE, AND HANDLING

- A. Comply with pertinent provisions of Section 01 66 11.

1.5 SITE CONDITIONS – Reserved.

1.6 MAINTENANCE – Reserved.

## PART 2 - PRODUCTS

### 2.1 GENERAL

- A. Design panel-mounted human machine interface (HMI) to replace traditional hard-wired panel devices such as pushbuttons, switches, pilot lights, digital displays, etc., with graphic video display.

### 2.2 PANEL-MOUNTED HMI

- A. Provide panel-mounted HMI with the following requirements:
  1. Display type: Color Active Matrix Thin Film Transistor (TFT) with field replaceable backlight.
  2. Display size: 6.5", 10.4", 12.1" or 15.1" diagonal as shown on the Drawings.
  3. Operator input: Touch-screen.
  4. Communication port: Ethernet or other industrial protocol as shown on the Drawings.
  5. Memory: As required for application.
  6. Real time clock: Battery-backed clock.
  7. Power: 18-32 VDC.
  8. Operating temperature: 0 to 55 degrees C.
  9. Rating: NEMA 12, 13, 4x, IP54, IP65.
  10. Certifications: UL Listed.
  11. Cables to connect to communication network.
  12. Acceptable manufacturers:
    - a. Allen Bradley, PanelView 1250 Plus.
    - b. Or equal.

## PART 3 - EXECUTION

### 3.1 INSTALLATION

- A. Install HMI in accordance with manufacturer's recommendations.
- B. Configure the HMI in accordance with manufacturer's instructions as shown on the Drawings.

END OF SECTION

## SECTION 40 94 43

## PROGRAMMABLE LOGIC PROCESS CONTROLLERS

## PART 1 - GENERAL

## 1.1 SUMMARY

- A. When existing devices specified in Section 40 90 10 (2.7) cannot be re-used: Provide programmable logic process controllers as shown on the Drawings, as specified herein, and as needed for a complete and proper installation.
- B. Related work:
  - 1. Documents affecting work of this Section include, but are not necessarily limited to, General Conditions, Supplementary Conditions, and Division 01 - General Requirements of these Specifications.
- C. References:
  - 1. Reserved.

## 1.2 SUBMITTALS

- A. Shop Drawing Submittals:
  - 1. Manufacturer's detailed specifications.
- B. Operation and Maintenance Manuals: Submit operation and maintenance manuals in compliance with pertinent provisions of Section 01 78 26.
- C. Certificates and Guarantees:
  - 1. Submit signed Certificate 00 62 78 "List of Schedule for Spare Parts".
- D. Spare Parts:
  - 1. System Integrator of Section 40 90 25 to supply spare parts.
    - a. Package all spare parts and label all packages with quantity, item description, and part number.
    - b. Comply with Certificate 00 62 78.
  - 2. Provide the following number of spare parts to the Owner that match items specified:
    - a. One spare processor unit for each unique processor installed.
    - b. One spare I/O Module for each unique I/O module type installed.
    - c. One spare communication module for each unique communication module installed.
    - d. One spare power supply for each unique power supply installed.

## 1.3 QUALITY ASSURANCE

- A. Provide all equipment by one manufacturer.

1.4 DELIVERY, STORAGE, AND HANDLING

- A. Comply with pertinent provisions of Section 01 66 11.

1.5 SITE CONDITIONS – Reserved.

1.6 MAINTENANCE – Reserved.

1.7 ENVIRONMENTAL REQUIREMENTS

- A. Maintain area free of dirt and dust during and after installation of products.

PART 2 - PRODUCTS

2.1 GENERAL

- A. Design Programmable Logic Controller (PLC) to accept input contact and analog signals, perform the functions specified, and output contact and analog signals to control and/or indicate the specified processes.
- B. Provide rack-mounted style PLC consisting of I/O racks, power supplies, CPUs, memory units, network communication modules and I/O modules.
  - 1. Provide a modular type system with the necessary number and type of inputs and outputs.
  - 2. Noise immunity to meet NEMA Standard ICS2-230.
  - 3. Rack-mounted module removable without disconnecting the wiring harness from its terminals.
  - 4. Provide expansion racks and power supplies at each location as required.
  - 5. Provide rack interconnect cables as required noting location of keyed plugs.
- C. Provide micro style PLC consisting of base unit with integral I/O, processor and power supply. Provide expansion I/O modules and network communication modules as required.
- D. Provide DIN rail mounted style PLC consisting of CPUs, power supplies, memory units, network communication modules and I/O modules.
  - 1. Provide a modular type system with the necessary number and type of inputs and outputs.
  - 2. Provide expansion modules and power supplies at each location as required.
  - 3. Provide expansion module interconnect cables as required.

2.2 RACK-MOUNTED PROGRAMMABLE LOGIC CONTROLLER

- A. Provide I/O rack with the following requirements:
  - 1. Modular style slotted mounting rack to support the power supply, CPU, and I/O modules.
  - 2. A minimum of two (2) spare slots after fully configured.
  - 3. Allows modules to slide into the racks along guides, without use of tools.



- B. Provide power supply with the following requirements:
  - 1. Mounted on the side of each of the racks to power the CPU and I/O modules.
  - 2. Replaceable fuse and AC voltage selection jumper located for 120 VAC, 60 Hertz.
  - 3. Sized to accommodate the full load capacity of the rack including spare slots.
  
- C. Provide Central Processing Unit (CPU) with the following requirements:
  - 1. Minimum 16K program memory and capable of controlling up to 4096 input and output points.
  - 2. Integral communication ports:
    - a. One RS-232.
    - b. One Ethernet, DH+, or DH-485 as shown on the Drawings.
  - 3. Lithium battery backed RAM user memory.
  - 4. Flash EPROM or EEPROM memory backup.
  - 5. Ability to program on-line or off-line.
  - 6. Embedded proportional-integral-derivative (PID) instruction.
  
- D. Provide memory unit with the following requirements:
  - 1. Flash EPROM or EEPROM non-volatile memory backup unit.
  - 2. Minimum 16K memory capacity.
  - 3. Ability to save the contents of the CPU RAM (Random Access Memory) for storage purposes and load the contents of the Flash EPROM or EEPROM back into the processor RAM.
  
- E. Provide 120 VAC or 24 VDC discrete input modules with 4, 8, or 16 photo-optically isolated inputs.
  
- F. Provide discrete output modules with the following requirements:
  - 1. Minimum 8 individually isolated relay type output points with each relay contact rated at 5A continuous, 120 VAC.
  - 2. Surge suppression component across each output, per manufacturer's recommendation.
  
- G. Provide high speed counter or flow meter input modules with minimum 4 input channels:
  - 1. Acceptable manufacturers: Spectrum Controls or equal.
  
- H. Provide analog input module with a minimum of 4 input channels selectable for a 4-20 mAdc current input, and input impedance of 250 ohms per channel.
  
- I. Provide analog output module with a minimum of 4 output channels selectable for a 4-20 mAdc current output and output impedance of 500 ohms per channel.
  
- J. Provide communication modules as required:
  - 1. DeviceNet Scanner with DeviceNet Redundant Power Supply.
  - 2. Remote I/O Scanner.
  - 3. Remote I/O Adapter.
  - 4. KE Module.

5. Modbus communication module.
  - a. Acceptable manufacturers: Prosoft Technology or equal.

K. Provide cables as required for connecting PLC to related devices.

L. Acceptable manufacturers:

1. Allen-Bradley: (SLC-5/05, SLC-5/04, SLC-5/03).
2. Or equal.

### 2.3 MICRO PROGRAMMABLE LOGIC CONTROLLER

A. Provide micro style programmable logic controller with the following requirements:

1. Base unit consisting of integrated power supply, processor unit and I/O termination points for a complete controller unit.
2. Ability to expand I/O capacity by adding compact I/O modules.
3. Communication ports:
  - a. One RS-232.
  - b. One RS-232 or Ethernet as shown on the Drawings.
4. Minimum 4K user memory.
5. Built-in PID instruction.
6. Real time clock.
7. Power source requirement: 120 VAC or 24 VDC.
8. Minimum ten 120VAC or 24VDC discrete inputs embedded on base unit.
9. Minimum six relay discrete outputs embedded on base unit.

B. Provide expansion I/O modules as required:

1. Discrete input modules: 16-point, 120VAC or 24VDC as required.
2. Discrete output modules: 8-point relay output.
3. Analog input modules: 4-channel, configurable for dc voltage or current.
4. Analog output modules: 2-channel, configurable for dc voltage or current.

C. Provide cables as required to connect PLC with related devices.

D. Acceptable manufacturers:

1. Allen-Bradley: MicroLogix 1500, MicroLogix 1200, or MicroLogix 1100.
2. Or equal.

### 2.4 DIN RAIL MOUNTED PLC

A. Common Hardware Ratings:

1. Operating Temperature range: 0°C to +55°C.
2. Storage Temperature range: -40°C to +85°C.
3. Humidity range: 5 to 95% non-condensing.
4. Noise Immunity in compliance to NEMA Standard ICS 2-230.
5. Operation Vibration Rating: 5.0 G at 10 to 500Hz, 0.030-inch peak-to-peak.
6. Isolation level: 1500V between backplane and I/O.
7. Dielectric withstand rating: 1500V ac in compliance with UL 508, CSA C22.2 No. 142.

- B. Processor Unit:
1. Program memory: 750K RAM, minimum.
  2. Capable of controlling up to (16) I/O modules.
  3. Proportional Integral Derivative Control with up to 451 microsecond execution time.
  4. Online programming including runtime editing.
  5. Standard RAM Memory Back-up provided through minimum two-year lithium battery.
  6. LED indicators for: POWER, RUN, CPU Fault, Forced I/O, Battery Low, DH485, RS-232.
  7. Two communication ports:
    - a. One RS-232 port that supports DF1 full-duplex, DF1 half-duplex master and slave, and ASCII protocols.
    - b. One Ethernet port that supports Ethernet/IP protocol.
  8. Real Time Clock.
  9. Key Switch Positions for Remote, Program and Run.
- C. Discrete Input Modules:
1. Operating voltage: 79 to 132V AC.
  2. Sixteen (16) Non-isolated inputs or eight (8) isolated inputs as required.
  3. Removable terminal block.
  4. LEDs to indicate the status of each I/O point.
- D. Analog Input Modules:
1. Four (4) input channels per module.
  2. Ratings:
    - a. Current Rating: 0 to 20mAdc, 4 to 20mAdc.
    - b. Voltage Rating: Plus/Minus 10Vdc, 0 to 10Vdc, 0 to 5Vdc, 1 to 5Vdc.
  3. Terminal Impedance:
    - a. Current Rating: 250 Ohms.
    - b. Voltage Rating: 220Kohms.
  4. LEDs to indicate the status of each I/O point.
- E. Relay Output Modules (Isolated):
1. Voltage rating: 5 to 265 Vac.
  2. Eight (8) Individually Isolated Relay outputs.
  3. Continuous current rating per point: 2.5A ac not to exceed 1440 VA for the module.
  4. Continuous current rating per module: 16A ac, 2.5A/common.
  5. LEDs to indicate the status of each I/O point.
  6. Optical isolation between digital and field circuits.
- F. Analog Output Modules:
1. Two (2 ) output channels per module, single-ended.
  2. Ratings:
    - a. Current Rating: 0 to 20mA, 4 to 20mA.
    - b. Voltage Rating of Plus/Minus 10Vdc, 0 to 10Vdc, 0 to 5Vdc, 1 to 5Vdc.
  3. LEDs to indicate the status of each I/O point.

- G. Expansion Power Supply:
  - 1. Line Voltage rating: 85 to 265 Vac.
  - 2. User Power Capacity: 250mA at 24Vdc.
  - 3. Short circuit protection via front access fuse with cover.
  - 4. Plus 5V and Plus 24V overvoltage protection.
  - 5. LED to indicate that input power is available.
- H. Provide communication modules as required:
  - 1. DeviceNet scanner.
- I. Provide taps and cables as required for connecting PLC to related devices.
- J. Acceptable manufacturers:
  - 1. Allen-Bradley: CompactLogix.
  - 2. Or equal.

## 2.5 INTERFACE CONVERTERS

- A. Provide the following interface converters as required:
  - 1. DF-1 to DH-485 Converter.
  - 2. DF-1 to DeviceNet Converter.
  - 3. DF-1 to Ethernet Converter.

## PART 3 - EXECUTION

### 3.1 INSTALLATION

- A. Install PLC in accordance with manufacturer's recommendations.
- B. Cover all unused rack slots with card slot fillers.
- C. Install component identification and wire tags on all wiring.

### 3.2 PROGRAMMING

- A. Program PLC in accordance with manufacturer's instructions, as described in Section 40 90 25, and as shown on the Drawings.

### 3.3 CLEANING

- A. Clean units as recommended by manufacturer.

END OF SECTION

## SECTION 40 95 13

## PROCESS CONTROL PANELS AND HARDWARE

## PART 1 - GENERAL

## 1.1 SUMMARY

- A. Provide process control panel and hardware as shown on the Drawings, as specified herein and as needed for a complete and proper installation.
- B. Related work:
  - 1. Documents affecting work under this Section include, but are not necessarily limited to, General Conditions, and Sections in Division 01 of these Specifications.
- C. Work under this Section includes:
  - 1. Providing pre-wired and programmed process control panels.
  - 2. Start-up and testing of the process control panels.
  - 3. Providing on-site training to the operations staff.

## 1.2 SUBMITTALS

- A. Shop Drawing Submittals:
  - 1. Control panels, components, PLC power supply loading calculations, UPS runtime calculation, sequence of operation description, and manufacturer's detailed specifications (cut-sheets or data sheets).
    - a. Each control panel supplier to submit documentation for all supplied control panels and components in one submittal package.
- B. Operation and Maintenance Manuals: Submit operation and maintenance manuals in compliance with pertinent provisions of Section 01 78 26.
- C. Certificates and Guarantees – None Required.
- D. Spare Parts – None Required.
- E. Submit control system drawings, including drawing index, bill of materials, control system configuration overview, panel dimensions and layouts, programmable logic controller (PLC) rack layouts, control wiring schematics, instrument loop diagrams, and panel/field interconnecting diagram.
  - 1. Submit the initial drawings on 11" x 17" sheets with the shop drawings.
  - 2. After the control and monitoring system is fully operational and all modifications have been made, submit the final as-built drawings as follows:
    - a. Four (4) printed copies on 11" x 17" sheets.
    - b. Four (4) electronic copies on CD-ROM compatible with AutoCAD.

## PROCESS CONTROL PANELS AND HARDWARE

40 95 13-1 (140218.40)

- F. Submit a factory or shop operational test report for each panel verifying hardware and functional requirements not less than 10 days prior to shipment of the panels.
- G. Submit PLC register mapping document listing data registers to be transmitted to other networked PLCs as shown on the Drawings or as specified elsewhere. Document to include register address, description, data format, and engineering units.
- H. Submit two (2) complete printed copies of the Human Machine Interface (HMI) graphic screen shots for each system, a minimum of two (2) weeks prior to start-up.
- I. Submit electronic copies of final programs and device configurations after Substantial Completion as follows:
  - 1. Four (4) CD-ROMS for each system prior to final completion. Documentation for multiple control panels can be provided on one CD. Provide the following documentation:
    - a. HMI application source code.
    - b. PLC application source code.
    - c. DeviceNet network device configuration file and electronic data sheet (EDS) files for connected devices.
    - d. Radio Transceiver configuration files.
    - e. All passwords and any other required information to configure any system component.

### 1.3 QUALITY ASSURANCE

- A. Assemble and wire all panels in factory or shop.
  - 1. Provide color-coded wiring in accordance with applicable codes and laws to facilitate maintenance and repair of control panel. Post color-coding schedule inside the control panel.
  - 2. Provide minimum 16 AWG control wires and provide spiral wrap, tie wrap, fasteners, and wire duct as required.
  - 3. Label all wiring at each end with numbers corresponding to the wiring schematics. Show numbering on the as-built drawings. Use tubular heat shrink-type or self-laminating vinyl wire markers printed using thermal printer.
  - 4. Label all terminal blocks with numbers corresponding to the wire numbers.
  - 5. Segregate wiring of different voltage levels.
  - 6. Provide nameplates for enclosure, instruments, devices and components. Descriptions on the nameplate to agree with the descriptions on the as-built drawings.
- B. Provide enclosures, devices, components, etc., which have been listed and labeled by Underwriter's Laboratories.
- C. Perform a factory or shop operational test on each panel.

### 1.4 DELIVERY, STORAGE, AND HANDLING

- A. Comply with pertinent provisions of Section 01 66 11.

1.5 SITE CONDITIONS – Reserved.

1.6 MAINTENANCE – Reserved.

1.7 ENVIRONMENTAL REQUIREMENTS

- A. Conform to Sections of Division 01 during and after installation of the control and monitoring systems.
- B. Maintain area, including enclosures, free of dirt and dust during and after installation of products.

## PART 2 - PRODUCTS

2.1 GENERAL

- A. Facilitate coordination between all processes to ensure seamless integration into the existing SCADA system where applicable.
- B. Provide PLC-based control panel to control and monitor the process equipment as specified in other Sections and as shown on the Drawings with the following requirements:
  - 1. Controller (processor) with adequate memory.
  - 2. Power supplies with adequate load capacity.
  - 3. Analog and discrete input/output modules to control and monitor all applicable signals required for proper operation.
  - 4. Communication modules to interface with the SCADA network and field devices.
  - 5. Human Machine Interface (HMI) with screen size as shown on the Drawings.

2.2 GENERAL PLC PROGRAMMING

- A. Provide time delays for motors, valves, alarms, etc. as follows:
  - 1. To prevent motors from starting at the same time when power is restored from power outage.
  - 2. To prevent false starts/stops or false alarm due to process spikes or input "bouncing".
  - 3. To prevent the 3<sup>rd</sup> large pump from operating (even in the "hand" mode) when the generator is operating.
- B. Provide monitoring of analog signals to determine if the signals are out of range, and alarm the out of range conditions.
- C. Provide programming to retain the timing, control and alarm setpoints in the event the HMI goes offline.
- D. Annunciate and indicate process alarms, limit alarms, motor failures, PLC faults, and mechanical equipment failures at local HMI and transmit to SCADA Server.

- E. Provide programming to allow operator acknowledgement of alarms using either of the following two methods as determined by the Owner:
  - 1. Allow acknowledgement via the SCADA Server only after user login is entered and log information in log file. Send acknowledgement information to local HMI to acknowledge alarm in HMI after acknowledged at SCADA Server.
  - 2. Allow acknowledgement at SCADA Server or at local HMI without logging user information when acknowledged at local HMI.
- F. Provide programming to annunciate PLC fault, communication loss, and low battery alarm.

### 2.3 GENERAL HUMAN MACHINE INTERFACE (HMI) PROGRAMMING

- A. Provide simple and consistent navigation system to branch to other screens, including but not limited to the following:
  - 1. Process status screen.
  - 2. Control/setpoint entry screens.
  - 3. Alarm status screen.
  - 4. Alarm history screen.
- B. Provide graphic screens to display the process status.
- C. Provide consistent color scheme to indicate equipment status as follows:
  - 1. Green = "On".
  - 2. Background or neutral color = "Off".
  - 3. Yellow = Required to operate, but not yet running.
  - 4. Blink Red = unacknowledged alarm.
  - 5. Solid Red = acknowledged alarm.
- D. Provide consistent color scheme to distinguish between operator adjustable control setpoints and view-only value displays.
- E. Provide data entry and control parameter adjustment screens to enter alarm setpoints, control setpoints, and select control sequence and process parameters.
- F. Provide screen to indicate solid state motor overload relay over-current setting and allow setting adjustment via password protected screen.
- G. Provide security passwords for access to control and data entry screens.
- H. Indicate if data setpoints entered are out of range and do not change setpoint.
- I. Display the alarm conditions as described elsewhere in this section.

### 2.4 GENERAL ALARM INDICATION IN HMI

- A. Display the alarm conditions on the following alarm screens at the HMI:
  - 1. Alarm history screen.



2. Alarm status screen (showing active alarms only).
  3. Pop-up alarm message window.
- B. Provide alarm indication with the following detail:
1. Time alarm occurred.
  2. Time alarm was acknowledged.
  3. Time alarm cleared.
  4. Location and/or equipment name.
  5. Alarm description.

## 2.5 ENCLOSURES, DEVICES, COMPONENTS

- A. Comply with applicable Sections in Divisions 26 and 40 for all equipment supplied under this Section.
- B. Provide pre-wired controls housed in an enclosure consisting of but not limited to the following as applicable and as shown on the Drawings:
1. Programmable Logic Controller (PLC).
  2. Human Machine Interface (HMI).
  3. Power supply systems as follows:
    - a. Uninterruptible power supply (UPS).
    - b. Redundant DC Power Supplies.
    - c. Redundant DeviceNet power supplies.
  4. Fused terminal blocks for power supply to field instruments.
  5. Surge protection to protect the following:
    - a. Analog and discrete signals from field instruments.
    - b. Power supplies leaving the building.
    - c. Main 120 volt power feed to control panel.
  6. Alarm horn, selector switches, push buttons, pilot lights, and other operator devices.
  7. Intrinsically safe relays.
  8. Control relays.
  9. Thermal management system to maintain components at rated temperature.
  10. Lighting package with remote mounted door switch.
  11. Corrosion inhibitors.
  12. Terminal blocks for field wiring:
    - a. Finger-safe, DIN rail mounted, with separation plates, end barriers, and end anchors as required.

## PART 3 - EXECUTION

### 3.1 INSTALLATION

- A. Install process control panels in accordance with manufacturer's recommendation and as follows:
1. Terminate all wiring between field devices.
  2. Ground the shield of instrumentation controls cable at one end only. Insulate the shield at the other end from the ground.

- B. Install nameplates and identification tags to comply with Section 26 05 53 and as follows:
  - 1. Label the enclosures, devices, and components.
- C. Touch-up and clean enclosures after the start-up.

### 3.2 START-UP AND TESTING

- A. Start-up and testing is responsibility of the process control panel supplier.
- B. Provide start-up and testing of process control panels in conjunction with the equipment it controls and as specified in other Sections of these Specifications.

END OF SECTION

## SECTION 40 95 70

## PROCESS CONTROL SURGE PROTECTORS

## PART 1 - GENERAL

## 1.1 SUMMARY

- A. Provide process control surge protectors as shown on the Drawings, as specified herein, and as needed for a complete and proper installation.
- B. Related work:
  - 1. Documents affecting work under this Section include, but are not necessarily limited to, General Conditions, Supplementary Conditions, and Division 01 - General Requirements of these Specifications.
  - 2. Comply with the requirements of Division 26 for any electrical work related to work in Division 40.
- C. References:
  - 1. Reserved.

## 1.2 SUBMITTALS

- A. Shop Drawing Submittals:
  - 1. Manufacturer's detailed specifications.
- B. Operation and Maintenance Manuals – None Required.
- C. Certificates and Guarantees – None Required.
- D. Spare Parts – None Required.

## 1.3 QUALITY ASSURANCE

- A. All equipment to be provided by one manufacturer.

## 1.4 DELIVERY, STORAGE, AND HANDLING

- A. Comply with pertinent provisions of Section 01 66 11.

## 1.5 SITE CONDITIONS – Reserved.

## 1.6 MAINTENANCE – Reserved.

## PART 2 - PRODUCTS

## 2.1 GENERAL

- A. Design surge protector to protect the electrical/electronics equipment from lightning, line transients and other damaging voltage spikes, and attenuate power line

disturbances such as voltage surge, spike, impulses or transient, to a safe, nondestructive level which matches the needs of the electrical/electronics equipment.

- B. Acceptable manufacturers:
1. MCG Electronics, Inc.:
    - a. Model 416 for AC Power Lines Surge Protector.
    - b. Model DLP-4.2 for Telephone Data Lines Surge Protector.
    - c. Model DLP-3.9 for I/O Ports Data Line Surge Protector.
  2. Or equal.

## 2.2 AC POWER LINES SURGE PROTECTORS

- A. Provide an AC power lines surge protector with the following requirements:
1. Rated voltage: 120 VAC 60 Hz.
  2. Rated current: 25A.
  3. Response: 1 nanosec.
  4. Surge voltage: 12,000A.
  5. Clamp voltage: 212V.
  6. Suppression voltage: 420V impulse, 250V ringwave.
  7. Surge energy: 400 joules.
  8. Filter: Attenuates conducted RFI.

## 2.3 DATA LINES SURGE PROTECTORS

- A. Provide telephone data lines surge protector with the following requirements:
1. Clamp voltage (10/1000 micro): +/-260V.
  2. Clamp threshold (1mA): +/-200V.
  3. Response time: 1 nanosecond.
  4. Data rate: 56 Kb maximum.
  5. Operating temp: -55°C to 85°C.
  6. Connectors line/load: RJ11.
  7. Ground reference: Ground post provided.
  8. Protected signal lines: 2 lines.
- B. Provide I/O ports data lines surge protector with the following requirements:
1. Clamp voltage (10/1000 micro):  $\pm 20V$ .
  2. Clamp threshold (1 mA):  $\pm 25V$  peak.
  3. Response time: 1 nanosecond.
  4. Data rate: 20 Kilobits/second.
  5. Connectors (line/load): DB9 or as required.
- C. Provide surge protector for DeviceNet System with the following requirements:
1. Clamp voltage: 119 Vpk (L-G), 56 Vpk (L-L).
  2. Maximum DC operating voltage: 19.8 Vdc (L-G), 5.6 Vdc (L-L).
  3. Maximum surge current: 1 kA.
  4. Maximum Capacitance A-B Lines: 20pf (L-L).
  5. Agency approval: UL 497B, CE.

6. Acceptable manufacturers:
  - a. Leviton, Cat No. 3863-DEV.
  - b. Phoenix Contact PlugTrab PT Series.
  - c. Or equal.
  
- D. Provide surge protector for Ethernet Data Networks with the following requirements:
  1. Clamp Voltage: 119 Vpk (L-G), 56 Vpk (L-L).
  2. Maximum DC operating voltage: 19.8 Vdc (L-G), 5.6 Vdc (L-L).
  3. Maximum surge current: 1 kA.
  4. Maximum Capacitance A-B Lines: 20pf (L-L).
  5. Agency approval: UL 497B, CE.
  6. Acceptable manufacturers:
    - a. Leviton, Cat No. 3861-ETH.
    - b. Phoenix Contact PlugTrab PT Series.
    - c. SixNet, SP-ETH Series.
    - d. Or equal.

## 2.4 CURRENT LOOP SURGE PROTECTORS

- A. Provide surge protector for current loop with the following requirements:
  1. Indoor application (mounted in the control panel):
    - a. Surge life: >100 operations with 200A, 10x1000usec.
    - b. DC leakage current at rated L-G voltage: >10uA.
    - c. Signal attenuation: 3db with 6000ohms termination.
    - d. Response time: 50 pico-seconds.
    - e. Operating temperature: -40C to 60C.
    - f. Peak signal voltage L-L: 28V.
    - g. Maximum data rate L-G: 4MHz.
    - h. Peak clamping voltage: 55 V L-L and L-G.
    - i. Load current: 150ma.
    - j. Capacitance 1800 pf. L-L and L-G.
    - k. Series resistance: 22 ohms.
    - l. Mounting: DIN Rail.
    - m. Acceptable manufacturers:
      - (1) Bourns, Model 1820-28-A3.
      - (2) Phoenix Contact PlugTrab PT Series.
      - (3) Or equal.
  2. Outdoor application:
    - a. Maximum signal voltage: 30Vpk.
    - b. DC clamping voltage: 36V L-L.
    - c. Capacitance, 1MHz maximum: 2000pF.
    - d. Inductance, per line maximum: 1uH.
    - e. DC leakage, 24 VDC maximum: 1uA.
    - f. Impulse clamping voltage: 50V L-L.
    - g. Operating temperature: 40C to 100C.
    - h. Maximum load current: 150 mA.
    - i. Component response time: 1 ns.
    - j. Surge life: 20 times (L-L)-G 20kA 8/20us.

- k. Housing: Schedule 40 stainless steel pipe nipple with 1/2-14 NPT connection.
- l. Acceptable manufacturers:
  - (1) Bourns, Model 1669-02 or 1669-06.
  - (2) Or equal.

### PART 3 - EXECUTION

#### 3.1 INSTALLATION

- A. Install surge protectors in accordance with manufacturer's recommendations.

END OF SECTION

## SECTION 40 95 74

## PROCESS CONTROL SIGNAL CONDITIONERS/CONVERTERS

## PART 1 - GENERAL

## 1.1 SUMMARY

- A. Provide process control signal conditioners/converters as shown on the Drawings, as specified herein, and as needed for a complete and proper installation.
- B. Related work:
  - 1. Documents affecting work under this Section include, but are not necessarily limited to, General Conditions, Supplementary Conditions, and Division 01 - General Requirements of these Specifications.
- C. References:
  - 1. Reserved.

## 1.2 SUBMITTALS

- A. Shop Drawing Submittals:
  - 1. Manufacturer's detailed specifications.
- B. Operation and Maintenance Manuals: Submit operation and maintenance manuals in compliance with pertinent provisions of Section 01 78 26.
- C. Certificates and Guarantees:
  - 1. Submit signed Certificate 00 62 78 "List of Schedule for Spare Parts".
- D. Spare Parts:
  - 1. System Integrator of Section 40 90 25 to supply spare parts.
    - a. Package all spare parts and label all packages with quantity, item description, and part number.
    - b. Comply with Certificate 00 62 78.
  - 2. Provide one spare unit for each unique type of unit installed.

## 1.3 QUALITY ASSURANCE – Reserved.

## 1.4 DELIVERY, STORAGE, AND HANDLING

- A. Comply with pertinent provisions of Section 01 66 11.

## 1.5 SITE CONDITIONS – Reserved.

## 1.6 MAINTENANCE – Reserved.

## PART 2 - PRODUCTS

### 2.1 SIGNAL CONDITIONER (ISOLATOR)

- A. Provide a single output isolator with the following requirements:
  - 1. Input: 4 to 20 mAdc.
  - 2. Output: Isolated 4 to 20 mAdc.
  - 3. Power supply: 120 Vac, 60 Hertz or loop powered.
  - 4. Mounting: Plug-in DIN rail socket.
  
- B. Provide a dual output isolator with the following requirements:
  - 1. Input: One (1) 4 to 20 mAdc.
  - 2. Output: Two (2) isolated 4 to 20 mAdc.
  - 3. Power supply: 120 Vac, 60 Hertz or loop powered.
  - 4. Mounting: Plug-in DIN rail socket.
  
- C. Acceptable manufacturers:
  - 1. Action Instruments.
  - 2. Absolute Process Instruments.
  - 3. Acromag.
  - 4. Or equal.

### 2.2 RESISTANCE TO CURRENT CONVERTER

- A. Provide potentiometer input signal converter to provide current output signal directly proportional to resistance input signal with the following requirements:
  - 1. Input: Potentiometer resistance.
  - 2. Output: Isolated 4 to 20 mAdc.
  - 3. Power supply: 120 Vac, 60 Hertz.
  - 4. Mounting: Plug-in DIN rail socket.
  
- B. Acceptable manufacturers:
  - 1. Action Instruments.
  - 2. Absolute Process Instruments.
  - 3. Acromag.
  - 4. Or equal.

### 2.3 CURRENT TO CURRENT CONVERTERS

- A. Provide current input signal converter to provide current output signal directly proportional to current input signal with the following requirements:
  - 1. Input: 0 to 5 amps AC.
  - 2. Frequency range: minimum 48 to 65Hz.
  - 3. Output: 4 to 20 mAdc; minimum 500 Ohms.
  - 4. Power supply: 120 VAC, 60 Hertz.
  - 5. Accuracy: +/- 0.25% F.S.
  
- B. Acceptable manufacturers:
  - 1. Flex-Core.



2. Or equal.

#### 2.4 LIMIT ALARM

- A. Provide a single trip field configurable limit alarm with the following requirements:
  1. Input: 4 to 20 mA dc.
  2. Output: Single trip DPDT.
  3. Power supply: 120 Vac, 60 Hertz or loop powered.
  4. Mounting: Plug-in DIN rail socket.
- B. Acceptable manufacturers:
  1. Action Instruments.
  2. Absolute Process Instruments.
  3. Acromag.
  4. Or equal.

### PART 3 - EXECUTION

#### 3.1 INSTALLATION

- A. Install process control signal conditioners/converters in accordance with manufacturer's recommendations.

END OF SECTION



SECTION 40 95 88  
POWER SUPPLY SYSTEMS

PART 1 - GENERAL

1.1 SUMMARY

- A. When existing devices specified in Section 40 90 10 (2.7) cannot be re-used: Provide power supply systems as shown on the Drawings, as specified herein, and as needed for a complete and proper installation.
- B. Related work:
  - 1. Documents affecting work of this Section include, but are not necessarily limited to, General Conditions, Supplementary Conditions, and Division 01 - General Requirements of these Specifications.
  - 2. Comply with the requirements of Division 26 for any electrical work related to work in Division 40.
- C. References:
  - 1. Reserved.

1.2 SUBMITTALS

- A. Shop Drawing Submittals:
  - 1. Manufacturer's detailed specifications.
- B. Operation and Maintenance Manuals: Submit operation and maintenance manuals in compliance with pertinent provisions of Section 01 78 26.
- C. Certificates and Guarantees – None Required.
- D. Spare Parts – None Required.

1.3 QUALITY ASSURANCE – Reserved.

1.4 DELIVERY, STORAGE, AND HANDLING

- A. Comply with pertinent provisions of Section 01 66 11.

1.5 SITE CONDITIONS – Reserved.

1.6 MAINTENANCE – Reserved.

## PART 2 - PRODUCTS

### 2.1 UNINTERRUPTIBLE POWER SUPPLY

- A. Design uninterruptible power supply (UPS) to supply the total power requirement of the system plus 25 percent for future expansion.
  - 1. Provide no-break transfer line to inverter and return.
  
- B. Provide UPS unit with the following requirements:
  - 1. Input: 120 VAC 60 Hertz, single phase.
  - 2. Output: voltage 120 VAC 60 Hertz, single phase, true sine wave.
  - 3. Battery time: 30 minutes minimum of running time at full load or 60 minutes minimum at half load.
  - 4. Battery: Sealed, lead acid 5-year-maintenance free.
  - 5. Input/output configuration:
    - a. Input: 6-foot line cord with 20A, 3-prong grounded plug (5-20P).
    - b. Output: minimum 2-duplex, 15A receptacles.
  - 6. Safety: UL listed.
  - 7. Acceptable manufacturers:
    - a. American Power Conversion (APC), Smart UPS.
    - b. Sola/Hevy-Duty S4K Series.
    - c. Allen Bradley 1609 Series.
    - d. Or equal.
  
- C. Provide control panel UPS with relay interface card with dry contact relay outputs to monitor the following UPS status:
  - 1. Battery On.
  - 2. Battery Low.
  - 3. Communication Loss.
  - 4. Overloaded.
  - 5. Fault.
  - 6. Replace Battery.
  
- D. Provide computer UPS with interface communications software for the UPS to automatically perform an orderly shutdown of the computer to prevent loss of data, to monitor operating status of the UPS hardware and power system, and graphically display power system/UPS status.
  - 1. Comply with Section 40 96 00.

### 2.2 DC POWER SUPPLY

- A. Design DC power supply to convert alternating current to direct current and supply the total power requirement of the system plus 25 percent for future expansion.
  
- B. Provide DC power supply with the following requirements:
  - 1. Input: 120 VAC, 60 Hertz.
  - 2. Output: DC voltage as required.
  - 3. Housing: Enclosed housing, DIN mounted.
  - 4. NEC Class 2.

5. Suitable for use as redundant power supply when connected to redundancy module (for 24 VDC power supplies).
  6. Complies with DeviceNet requirements for DeviceNet power supplies.
  7. Output contact to indicate power supply fault.
  8. Acceptable manufacturers:
    - a. Sola/Hevi-Duty SDN "P" Series.
    - b. Allen Bradley Bulletin 1606-XL.
    - c. Or equal.
- C. Provide Redundant DC power supply module with the following requirements:
1. Nominal voltage: 24VDC.
  2. Housing: Enclosed housing, DIN mounted.
  3. Allows two 24VDC power supplies to be connected to module using isolated inputs.
  4. NEC Class 2.
  5. Output contact to indicate module fault.
  6. Acceptable manufacturers:
    - a. Sola/Hevi-Duty SDN RED Series.
    - b. Allen Bradley Bulletin 1606-XLRED.
    - c. Or equal.

### PART 3 - EXECUTION

#### 3.1 INSTALLATION

- A. Install power supply systems in accordance with manufacturer's recommendations.

END OF SECTION



## SECTION 40 95 92

## RELAYS

## PART 1 - GENERAL

## 1.1 SUMMARY

- A. Provide relays as shown on the Drawings, as specified herein, and as needed for a complete and proper installation.
- B. Related work:
  - 1. Documents affecting work of this Section include, but are not necessarily limited to, General Conditions, Supplementary Conditions, and Division 01 - General Requirements of these Specifications.
- C. References:
  - 1. Reserved.

## 1.2 SUBMITTALS

- A. Shop Drawing Submittals:
  - 1. Manufacturer's detailed specifications.
- B. Operation and Maintenance Manuals – None Required.
- C. Certificates and Guarantees:
  - 1. Submit signed Certificate 00 62 78 "List of Schedule for Spare Parts".
- D. Spare Parts:
  - 1. System Integrator of Section 40 90 25 to supply spare parts.
    - a. Package all spare parts and label all packages with quantity, item description, and part number.
    - b. Comply with Certificate 00 62 78.
  - 2. Provide one spare relay for each type of relay installed.

## 1.3 QUALITY ASSURANCE – Reserved.

## 1.4 DELIVERY, STORAGE, AND HANDLING

- A. Comply with pertinent provisions of Section 01 66 11.

## 1.5 SITE CONDITIONS – Reserved.

## 1.6 MAINTENANCE – Reserved.

## RELAYS

40 95 92-1 (140218.40)

## PART 2 - PRODUCTS

### 2.1 GENERAL PURPOSE RELAYS

- A. Design general purpose relays to operate as follows:
1. On application of control power to relay coil, contacts reverse state.
  2. Contacts return to de-energized state on removal of control power.
- B. Provide general purpose relays with the following requirements:
1. Plug-in blade type.
  2. Contacts:
    - a. Material: Silver cadmium oxide.
    - b. Rating: Minimum of 10A at 120 VAC.
    - c. Two Form C, minimum. Provide number of contacts for each relay as required for application.
  3. Duty cycle: Continuous.
  4. Relay sockets with barrier-type screw terminal connections for external wiring:
    - a. Surface or DIN rail mount.
    - b. Relay hold-down clips.
  5. Lamp indication when relay is energized.
  6. Acceptable manufacturers:
    - a. IDEC, RH Series.
    - b. Or equal.

### 2.2 DELAY-ON-MAKE (ON-DELAY) TIME DELAY RELAYS

- A. Design delay-on-make time delay relays to operate as follows:
1. On application of voltage to the coil, the relay contacts remain in the "off state" and timing cycle begins. When the set time has elapsed the relay contacts transfer to the "on state". The contacts remain in the "on state" until the timer is reset. The timer is reset upon removing the coil voltage. Timer is then ready for the next operation.
- B. Provide delay-on-make time delay relays with the following requirements:
1. Plug-in blade type.
  2. Repeat timing accuracy: Plus or minus 1.5 percent.
  3. Minimum setting: 10 percent of full range.
  4. Duty cycle: Continuous.
  5. Timing range: 0.1 sec. - 10 min.
  6. Contacts:
    - a. Material: Silver cadmium oxide.
    - b. Rating: 10A at 120 VAC.
    - c. Two Form C.
  7. Relay sockets with barrier-type screw terminal connections for external wiring.
    - a. Surface or DIN rail mount.
    - b. Relay hold-down clips.



8. Acceptable manufacturers:
  - a. IDEC, RTE Series.
  - b. Or equal.

### 2.3 DELAY-ON-BREAK (OFF-DELAY) TIME DELAY RELAYS

- A. Design delay-on-break time delay relays to operate as follows:
  1. Voltage is applied to the coil at all times. When a momentary or maintained start signal is supplied the contacts immediately transfer to "on state". The set time begins when the start signal is removed. When the set time has elapsed, the contacts transfer to the "off state". The contacts remain in the "off state" until the next start signal is supplied. The timer can be reset by application of a reset input or by removing coil voltage.
- B. Provide delay-on-energize time delay relays with the following requirements:
  1. Plug-in blade type.
  2. Repeat timing accuracy: Plus or minus 1.5 percent.
  3. Minimum setting: 10 percent of full range.
  4. Duty cycle: Continuous.
  5. Timing range: 0.1 sec.- 10 min.
  6. Contacts:
    - a. Material: Silver cadmium oxide.
    - b. Rating: 10A at 120 VAC.
    - c. Two Form C.
  7. Relay sockets with barrier-type screw terminal connections for external wiring.
    - a. Surface or DIN rail mount.
    - b. Relay hold-down clips.
  8. Acceptable manufacturers:
    - a. IDEC, RTE Series.
    - b. Or equal.

### 2.4 MOTORIZED RESET TIMERS (BACKSPIN TIMERS)

- A. Design motorized reset timers (backspin timers) with synchronous timing motor driven reset timer suitable for door panel-mounting and reverse clutch operation to operate as follows:
  1. Timing cycle begins when control power is removed from the clutch. Control power must remain applied to the timing motor for the timing cycle to begin.
  2. Four sets of contacts that operate as follows:
    - a. Two sets change state when the "clutch" is energized and return to normal state when the clutch is de-energized.
    - b. One set changes state when the timing cycle has been completed.
    - c. One set changes state at approximately 5 percent of the timing cycle and will stop the timing motor ending the timing cycle
- B. Provide motorized reset timers with the following requirements:
  1. Control power: 120 VAC, 60 Hertz.
  2. Timing range to be 0 to 10 minutes.

3. Calibrated scale and adjustable knob with red progress pointer.
4. Reset time: One-half second at maximum setting.
5. Contacts:
  - a. Rating: 10A at 120 VAC, 5 amps at 240 VAC.
  - b. Four Form C that function as described above.
6. Power indication: Neon pilot light.
7. Standards recognition: U.L., CSA, and F.M.
8. Acceptable manufacturers:
  - a. Eagle Signal Control, Model HP5-4-A6-01-00.
  - b. Or equal.

## 2.5 POWER CONTROL RELAYS

- A. Design power control relays to operate as follows:
  1. On application of control power to relay coil, contacts reverse state.
  2. Contacts return to de-energized state on removal of control power.
- B. Provide power control relay for heavy-duty switching operation with the following requirements:
  1. Screw-mounted type with screw type terminals.
  2. Contacts:
    - a. Material: Silver cadmium oxide.
    - b. Rating: 25A at 277 VAC, 1 horsepower per movable arm at 120 VAC.
    - c. Two Form C, minimum.
  3. Duty cycle: Continuous.
  4. Coil operating voltage: 120 VAC.
  5. Acceptable manufacturers:
    - a. Potter and Brumfield.
    - b. Or equal.

## 2.6 MULTIFUNCTION TIMERS

- A. Design multifunction timers with synchronous timing motor drive suitable for flush panel mounting.
- B. Provide multifunction timers with the following requirements:
  1. Control power: 120VAC, 60 Hz.
  2. Running reserve: 100 Hr.
  3. Minimum switch time: 20 minutes.
  4. Interval: 10 minutes.
  5. Contacts:
    - a. Rating: 10A at 120 VAC, 5A at 240 VAC.
    - b. Form C.
  6. Acceptable manufacturers:
    - a. IDEC Model GT3D4AF20.
    - b. Or equal.

PART 3 - EXECUTION

3.1 INSTALLATION

- A. Install relays in accordance with manufacturer's recommendations.

3.2 CALIBRATION

- A. Calibrate and program equipment to meet system requirements.

3.3 START-UP AND TESTING

- A. Comply with the manufacturer's recommended testing procedures.

END OF SECTION



SECTION 40 97 96  
PROCESS SWITCHES

PART 1 - GENERAL

1.1 SUMMARY

- A. Provide process switches as shown on the Drawings, as specified herein, and as needed for a complete and proper installation.
- B. Related work:
  - 1. Documents affecting work of this Section include, but are not necessarily limited to, General Conditions, Supplementary Conditions, and Division 01 - General Requirements of these Specifications.
- C. References:
  - 1. Reserved.

1.2 SUBMITTALS

- A. Shop Drawing Submittals:
  - 1. Manufacturer's detailed specifications.
- B. Operation and Maintenance Manuals – None Required.
- C. Certificates and Guarantees – None Required.
- D. Spare Parts – None Required.

1.3 QUALITY ASSURANCE – Reserved.

1.4 DELIVERY, STORAGE, AND HANDLING

- A. Comply with pertinent provisions of Section 01 66 11.

1.5 SITE CONDITIONS – Reserved.

1.6 MAINTENANCE – Reserved.

PART 2 - PRODUCTS

2.1 PRESSURE SWITCHES

- A. Design pressure switches to toggle switch contacts based on decreasing pressure (low pressure setting), and return to normal position on increasing pressure (high pressure setting).

- B. Provide pressure switches with the following requirements:
1. Single setpoint switch or dual setpoint switch as shown on Drawings.
  2. Sensing device: Force-balanced, piston-actuated assembly sealed by a flexible diaphragm and a static O-ring.
  3. Wetted parts: Pressure port, diaphragm and O-ring.
  4. Housing: Aluminum, NEMA 4 rated with 3/4-inch NPT (F) electrical connection(s).
  5. Adjustable range: 20 to 180 psi.
  6. Typical deadband: 1.4 psi.
  7. Contacts (single setpoint switch): One SPDT rated at 15A, 250 VAC with deadband multiplier of one.
  8. Contacts (dual setpoint switch): Two SPDT rated at 15A, 250 VAC with deadband multiplier of one, independently adjustable for each setpoint.
  9. Electrical connection type: Screw terminals.
  10. Diaphragm material: Teflon coated polyimide (TCP).
  11. O-ring material: Buna-N.
  12. Process connection: 1/2-inch NPT (F), 316 stainless steel.
  13. Acceptable manufacturers:
    - a. SOR Inc., Series 6N3 for single setpoint switch, Series 66V1 for dual setpoint switch.
    - b. Or equal.

## 2.2 PRESSURE SENSOR ISOLATOR RING ASSEMBLIES

- A. Provide pressure sensor isolator ring assemblies composed of the following:
1. Pressure sensor isolator ring.
  2. Dual setpoint pressure switch.
  3. Pressure gauge.
  4. Acceptable manufacturers:
    - a. Ashcroft.
    - b. Red Valve.
    - c. Robin Myers.
    - d. Or equal.
- B. Provide sensor isolator rings with the following requirements.
1. Transmits process fluid pressure by liquid sealed between a steel housing and flexible sensor elastomer.
  2. Construction: Non-wetted carbon steel body, ANSI B16.5 Class 150 flanges in Carbon steel.
  3. Sensor elastomer: Teflon coated Buna-N.
  4. Fill fluid: silicone oil.
  5. Size: as shown on the Drawings.
- C. Provide non-indicating dual setpoint pressure switches as specified above.
- D. Provide pressure gauge in compliance with Section 22 19 26.

## 2.3 INSTRUMENT PIPING

- A. Comply with Section 22 19 13.
- B. Provide properly sized snubbers, shut-off valves, and fittings for pressure switches.

## 2.4 CURRENT METERING RELAYS

- A. Design current metering relays capable of sensing current on a 3-phase alternating current (AC) system and operates as follows:
  - 1. Toggles switch contacts when the current in any of the phases reaches the set value.
  - 2. Resets contacts when the current in all 3 phases drops to a value at least 10-percent below the set value or by interrupting the power supply.
- B. Provide current metering relays and three phase current transformers with the following requirements:
  - 1. Current metering relays.
    - a. Operating voltage: 120 VAC.
    - b. Contacts: One Form C rated at 10A, 120 VAC.
    - c. Setpoint adjust: Knob on face of relay.
    - d. Indication: LED for "ON" indication.
    - e. Hysteresis: Approximately 10-percent, adjustable to 75-percent with external resistor.
    - f. Mounting configuration: Plug-in 11-pin (octal), DIN rail mounting with hold down spring.
  - 2. Current metering transformers.
    - a. Current ranges:
      - (1) 0.5 to 5 Amperes RMS.
      - (2) 2 to 20 Amperes RMS.
      - (3) 10 to 100 Amperes RMS.
      - (4) 50 to 500 Amperes RMS.
    - b. Output voltage: 0.1 to 4 Volts peak.
  - 3. Acceptable manufacturers:
    - a. Electromatic Controls Corporation Model SM 115 relay with Models MP 3005, 3020, 3100, or 3500 current transformer.
    - b. Or equal.

## 2.5 CONDUCTIVITY SWITCHES

- A. Provide conductivity switches consisting of control module, electrodes and probe fittings with the following requirements:
  - 1. Control Module:
    - a. Solid state, plug-in module.
    - b. DIN mount 8-pin socket with screw-type connections.
    - c. Inverse or direct mode of operation as required.
    - d. Contacts: One Form C rated at 10A, 120 VAC.
    - e. Sensitivity: Field adjustable 0 to 1 meg-ohms.
    - f. Primary voltage 120 VAC.

- g. Secondary voltage 12 VAC.
  - 2. Electrodes:
    - a. Construction: 316SS.
    - b. Length: as required.
    - c. Solid construction with one threaded end to screw into coupling on fitting.
  - 3. Probe fittings:
    - a. Housing: General Purpose, cast metal.
    - b. Body material: 316SS.
    - c. Number of electrodes: As required for application.
- B. Acceptable manufacturers:
- 1. Warrick Controls, Series 16VM Control Module, Series 3R electrodes, Series 3E probe fitting.
  - 2. Or equal.

## 2.6 INDUCTIVE LEVEL SWITCHES

- A. Provide inductive level switches composed of induction relay and electrodes with the following requirements:
- 1. Relay:
    - a. NEMA 1 enclosure.
    - b. Voltage: 120Vac.
  - 3. Electrodes:
    - a. Construction: 316SS.
    - b. Length: as required.
- C. Acceptable manufacturers:
- 1. BW Controls, Series 5200.
  - 2. Or equal.

## PART 3 - EXECUTION

### 3.1 INSTALLATION

- A. Install process switches in accordance with manufacturer's recommendations.

### 3.2 CALIBRATION

- A. Calibrate and program equipment to meet system requirements.

### 3.3 START-UP AND TESTING

- A. Comply with the manufacturer's recommended testing procedures.

END SECTION

PROCESS SWITCHES  
40 97 96-4 (140218.40)



## SECTION 44 42 56.13

## WATER BOOSTER PUMPING EQUIPMENT INSTALLATION

## PART 1 - GENERAL

## 1.1 SUMMARY

- A. Install and electrically connect two new centrifugal booster pumps (Booster Pumps 3 and 4) as specified herein and as needed for a complete and functioning unit.
- B. New centrifugal booster pumps noted as shaded in the PRODUCTS section of this specification will be provided by Others. The Provider of the new booster pumps will deliver the booster pumps and motors to Booster Pumping Station 115 for installation by the Installation Contractor. **Shaded product information noted in this specification is for the Installation Contractor information only.**
- C. Pumps shall meet requirements for NSF/ANSI 61 Drinking Water System - Health Effects, and certified to be Lead-Free in accordance with NSF/ANSI 372.

## 1.2 START UP SERVICES

- A. Comply with pertinent provisions of Section 01 91 58 regarding acceptance of installation and field start-up.

## PART 2 - PRODUCTS

## 2.1 WATER SERVICE PUMPS

- A. Products noted as shaded in this section will be provided by Owner, but installed by Installation Contractor.
- B. Provide two horizontal, flexible coupled, split-case, double suction, single stage, centrifugal type pumps mounted with the motor on a common rigid steel frame base.
  1. Capacity of each pump - 2,100 gpm when operating against a total head of 190 feet at a maximum nominal speed of 1,800 rpm.
  2. Provide pumps to meet rotation shown on drawings.
  3. Available net positive suction head at worst case design is 30 feet with normal available net positive suction head at 40 feet.
  4. Equip each pump with single mechanical seals with adequate flushing (either with internal or through external brass 1/4" piping) GR 4140 carbon steel shaft, stainless steel sleeves, bronze impeller with renewable wear rings, bronze or cast iron wear rings, and grease lubricated ball bearings.
  5. Provide 1/4-inch NPT gauge taps on suction and discharge flange openings.
  6. Provide low zinc silicon bronze impellers bronze alloy impeller meeting NSF/ANSI 372 meeting the Lead-Free Act requirements and suitable for continuous contact with water containing 2 milligrams per liter free chlorine.

7. Provide a one piece bent form steel base plate, with provisions for anchoring to concrete base and grouting in place.
8. Provide with manufacturer's prime coat paint on all metallic surfaces to accept an exterior non-immersion. Tnemec System Series 1075 Endura-Shield final coat, with Omnithane and Hi-build Epoxy 1<sup>st</sup> and 2<sup>nd</sup> coats.
9. Connect pump to motor with a flexible coupling.
  - a. Acceptable manufacturer:
    - (1) Woods Sure-Flex, or equal.
  - b. Non-metallic elements.
  - c. Provide OSHA approved coupling guard.

C. Provide continuous duty rated motor with inverter duty grade insulation system, suitable to use with a VFD and meeting NEMA MG-1 Part 31, with sealed grease lubricated bearings, copper wound for 480 volt, 3 phase, 60 Hertz A.C. with Class F non-hygroscopic insulation for 40 degree C temperature rise over 40 degree C ambient temperature, and a service factor of 1.15. Efficiency rating shall be premium efficient. Provide 3 normally closed over-temperature switches embedded in the windings.

1. Motor to be TEFC design with 120 volt space heater.
2. Provide motor with manufacturer's prime and final coatings with no field painting required.
3. Provide adequate horsepower to be non-overloading throughout the pump capacity-head curve, minimum 150 Hp.
4. Acceptable motor manufacturers: US Motors, GE, Baldor, or Marathon Electric.

D. Base Bid pump manufacturers:

1. Fairbanks Morse, Model 1824, 6x5x16.5
2. Deming Pumps, Model 5063, 8x6x17.
3. Approved Equal.
4. Or Pre-approved equal.

E. Alternate pump manufacturers/providers must meet the following criteria:

1. Pre-approved by Owner as allowed in Bidding Documents.
2. Nominal 1,800 rpm speed, only.
3. Published pump efficiency greater than nominal 79% at full speed and greater than 75% at a reduced speed to obtain a minimum flow rate of 1,000 gpm at 140 feet.
4. Maximum run-out operating head (at maximum pump output at far right hand side of curve within Allowable Operating Region) of 160 feet.
5. Minimum shut off head (at 0 gpm) of 250 feet.
6. Ability to pump within Allowable Operating Region to at least 500 gpm or less at 130 feet of head.
7. Proof of equal materials of construction, quality, durability, appearance, strength and design characteristics.
8. Nationally recognized pump manufacturer with satisfactory installation and performance record within US and Wisconsin.
9. Local and responsive service within 90 miles of installation.

## 2.2 WARRANTY

- A. Provide two year warranty against defective equipment in compliance with pertinent provisions of Supplementary Conditions.

## PART 3 - EXECUTION

### 3.1 BOOSTER PUMP PROVIDER INSTALLATION REQUIREMENTS

- A. Pump Provider shall deliver water booster pumps and motors on frame to job site for installation by General Contractor. Coordinate delivery per General Contractor's construction schedule. Delivery shall include shipment to site and safe off-loading from delivery vehicle.
- B. Pump Provider shall provide General Contractor (and General Contractor's designated mechanical and electrical subcontractors) with manufacturer's recommendations for proper installation.
- C. Pump Provider shall provide inspection of final installation and prepare an installation report prior to final field testing and acceptance of pumping units by Owner.
- D. Pump Provider shall provide an extended 2-year warranty covering defective parts on booster pumping equipment to Owner at time of delivery.

### 3.2 BOOSTER PUMP INSTALLATION REQUIREMENTS

- A. Install pumps in accordance with manufacturer's recommendation including concrete bases, grout, anchorment, final alignment, piping and electrical connections.
- B. Install 1/4-inch steel nipple with shut-off cock and threaded end cap on each pump suction and discharge nozzle for pressure gauge connections.
- C. Install 1/2-inch piping with isolation valve from vent on top of each pump casing. Terminate in downturned elbow with 24 mesh stainless steel screen.
- D. Test in field and submit startup report.

END OF SECTION

I:\CRYSTAL LAKE\MADUD\140218 - BPS 115\CADD\DRAWINGS\DWG\140218-TOPO\_C3D.DWG PROPOSED  
 Plotted: 12/8/2014 9:29 AM By: 064RGE  
 Copyright © 2014, By Baxter & Woodman, Inc.  
 State of Wisconsin - Professional Design Firm  
 License No. - 484-011 - Expires 1-31-14

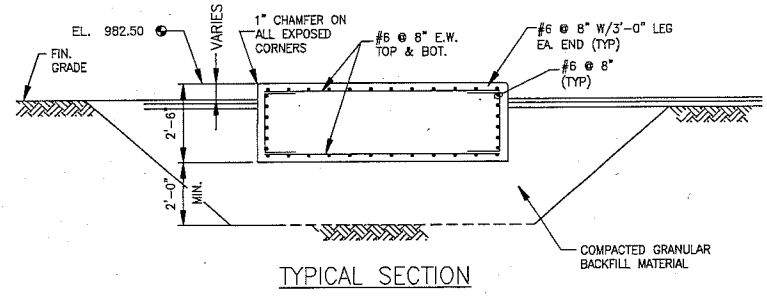
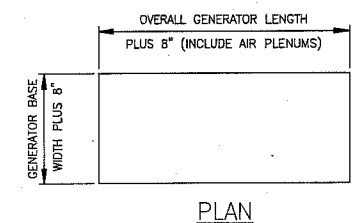
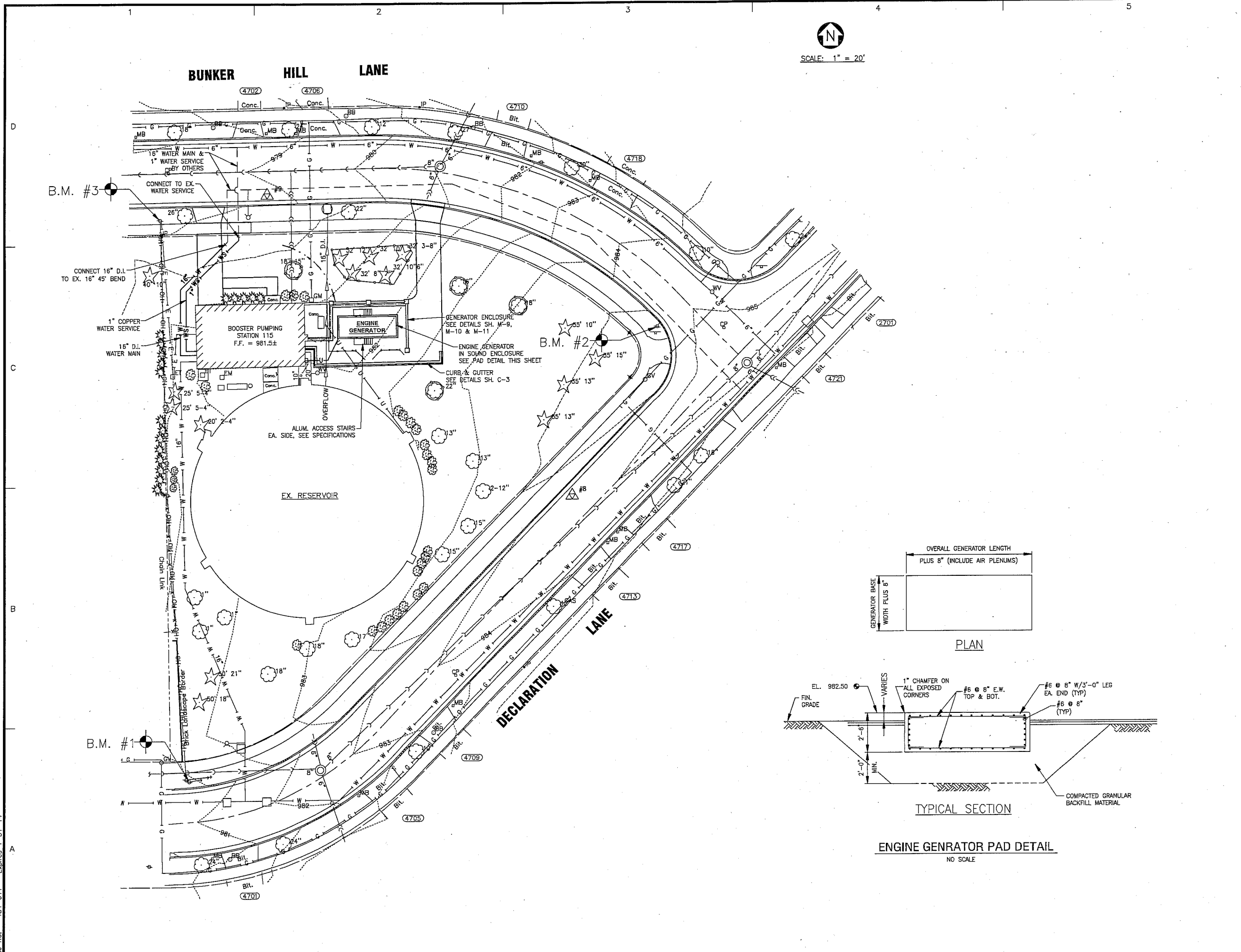

ENGINE GENERATOR PAD DETAIL  
NO SCALE

**BAXTER & WOODMAN**  
Consulting Engineers

CONSULTANTS

NO.	DATE	REVISIONS DESCRIPTION

REFER TO EQUIPMENT MANUFACTURER'S SHOP DRAWING

PLAN SHEET DESIGNATION

C	COVER
G	GENERAL
H	HAZARDOUS MATERIALS
I	CIVIL
L	LANDSCAPE
S	STRUCTURAL
A	ARCHITECTURAL
I	INSTRUMENTATION EQUIPMENT
T	FIRE PROTECTION
P	PLUMBING
M	MECHANICAL
E	ELECTRICAL
T	TELECOMMUNICATIONS
R	RESOURCE

PROJECT NO: 140218

SCALE:	AS NOTED
DRAWING DATE:	12-1-2014
DESIGNED BY:	GDC
DRAWN BY:	RGE
CHECKED BY:	GDC

CLIENT  
**MADISON WATER UTILITY  
MADISON, WISCONSIN**

**WATER SYSTEM IMPROVEMENTS  
BOOSTER PUMPING STATION 115  
UPGRADE**

SHEET TITLE  
**SITE PIPING PLAN**

**C-2**

Quality and Reliability since 1872

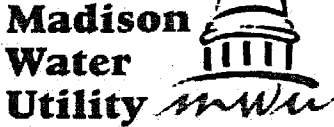

www.madisonwater.org • 119 East Olin Avenue • Madison, WI 53713-1431 • TEL 608-266-4651 • FAX 608.266.4426

## NOTICE OF ADDENDUM -

### CONTRACT NO. 7411

DATE: January 6, 2015

FROM: Baxter & Woodman, Inc., Consulting Engineers

TO: Planholders of record for the Work titled:

MADISON WATER UTILITY, MADISON, WISCONSIN  
WATER SYSTEM IMPROVEMENTS  
BOOSTER PUMPING STATION 115 UPGRADE

The Bidding Documents are amended as follows:

1. SECTION A: ADVERTISEMENT FOR BIDS AND INSTRUCTIONS TO BIDDERS
  - A. Add the following acceptable prequalification categories to Page A-3:
    1. 445, Plumbing
    2. 455, Pump Systems
2. DRAWINGS
  - A. Drawing C-2, Site Piping Plan
    1. Change reinforcing for Engine Generator Pad as shown in revised Engine Generator Pad Detail, as noted on revised Drawing C-2 (attached to this addendum).
  - B. Drawing M-9, Generator Enclosure Detail
    1. Change reinforcing for footing walls and masonry wall as shown in revised Sections A and B, as note on revised Drawing M-9 (attached to this addendum).
  - C. Drawing M-10, Generator Enclosure Details
    1. Delete existing note 6 and replace with new notes 6 through 9 and Change reinforcing for footings and masonry walls as shown in revised Details 1, 2 and 3 as noted on revised Drawing M-10 (attached to this addendum).
  - D. Drawing M-11, Generator Enclosure Exterior Elevations

1. Change footing wall elevations as shown on North, West and South Elevations as noted on revised Drawing M-11 (attached to this addendum).

E. Drawing E-3, Electrical Details

1. Add the following item to Note 10 of "Replacement MCC Notes", located in upper left-hand corner of drawing E-3; "d. 2#14 (Spares for use as O-Temp wires when Ex. Motor is Replaced in Future w/ Inverter Duty Motor) for Ea. BP-1 and BP-2."

3. SPECIFICATIONS

A. Section 22 19 13, PIPE AND PIPE FITTINGS: 2.1 DUCTILE IRON PIPE (DIP) AND FITTINGS

1. Page 22 19 13-1, Delete the words "or A21.53" in paragraph 2.1. C. 1. (Note this will only allow full bodied underground fittings to be utilized per ANSI 21.10 or AWWA C100.)
2. Page 22 19 13-2, Add the following to the end of paragraph 2.1. C. 3. Bolts and Nuts: "b. Cor Blue bolts and nuts, manufactured from corrosion-resistant, high-strength, low-alloy steel in accordance with ANSI/AWWA C111/A21.11, that has a baked-on ceramic-filled fluorocarbon resin."

B. Section 22 19 23, VALVES: 2.10 RESERVOIR ALTITUDE VALVE

1. Page 22 19 23-6, Replace the words "dual limit switches" in paragraph 2.10. B. 5. to read: "single limit switch (X105LCW)".
2. Page 22 19 23-6, Replace the words "Or equal" in paragraph 2.10. C. 2. to read: "Pre-approved Equal".

C. Section 22 19 23, VALVES: 2.11 HIGH ZONE/LOW ZONE TRANSFER VALVE

1. Page 22 19 23-7, Replace the words "dual limit switches" in paragraph 2.11 B. 5. to read: "single limit switch (X105LCW)".
2. Page 22 19 23-7, Add the following to the end of paragraph 2.11. B. as follows; "9. Provide adjustable parallel pressure relief function to relieve high pressures (90 to 120 psi) from the high pressure zone and provisions for return flow in case of pressure reversal."
3. Page 22 19 23-7, Replace the words "Cla-Val Model 92-01" in paragraph 2.11 C. 1) as follows; "Cla-Val Model 92-98".
4. Page 22 19 23-7, Replace the words "Or equal" in paragraph 2.11. C. 2. to read: "Pre-approved Equal".

Nothing in this Addendum shall be construed as changing other requirements of the Bidding Documents.

Please acknowledge this addendum on page E1 of the contract documents and/or in Section E: Bidder's Acknowledgement on Bid Express.

Electronic version of these documents can be found on the Bid Express web site at:

<http://www.bidexpress.com>

If you are unable to download plan revisions associated with the addendum, please contact the Engineering office at 608-266-4751 receive the material by another route.

END OF ADDENDUM NO. 1

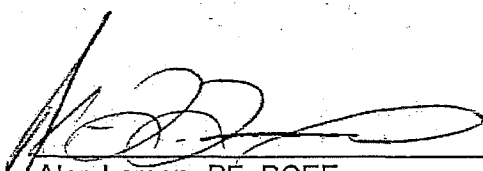
 1-6-15  
Alan Larson, PE, BCEE  
Madison Water Utility Principal Engineer

### REPLACEMENT MCC NOTES

- ARRANGE LAYOUT OF REPLACEMENT MCC TO FACILITATE RE-USE OF EXISTING CONDUITS STUBBED THROUGH FLOOR FOR MG&E SERVICE WIRES, MAIN GND. WIRE, PUMP WIRES & CONTROL WIRES/CABLES.
- REPLACEMENT MCC DIMENSIONS NOT TO EXCEED 16'-0" LONG X 7'-6" HIGH X 1'-8" DEEP.
- LENGTHEN CONC. BASE TO ACCOMMODATE REPLACEMENT MCC.
- PROVIDE REPLACEMENT MCC W/BARRIERED CT COMPARTMENT IN COMPLIANCE W/MG&E REQUIREMENTS.
- PROVIDE REPLACEMENT MCC W/TOUCH SCREEN, PROGRAMMING PORT, PLC, UPS & SAME FUNCTIONALITY AS SYSTEMS PROVIDED AT OTHER MADISON WATER UTILITY SITES BY ALTRONEX CONTROL SYSTEMS DIVISION OF L.W. ALLEN, INC.
- PROVIDE MAIN CIRCUIT BREAKER IN REPLACEMENT MCC PER MG&E REQMTS. & W/MIN. INTERRUPT RATING OF 18KA & W/AUX. CONTACT SET SERIES CONNECTED TO ENGINE START/RUN OCT. TO PREVENT GENSET RUNNING WHEN IN AUTO MODE & MAIN CIRCUIT BREAKER IS OFF OR TRIPPED.
- ADJUST CARRIER FREQUENCY OF VFD'S TO BETWEEN 2 KHZ & 4 KHZ TO PRODUCE WHINE AT VFD'S & MOTORS AT A FREQUENCY BEYOND RANGE OF HUMAN HEARING.
- PROVIDE 1" CONDUIT RUNNING INSIDE REPLACEMENT MCC FROM CT COMPARTMENT TO METER SOCKET FOR WIRE HARNESS PROVIDED BY MG&E.
- PROVIDE CONTROLS COMPARTMENT AT RIGHT END (EAST END) OF MCC LINE-UP.
- IN ALTERNATIVE LUMP SUM BID PROVIDE THE FOLLOWING:
  - VFD & LINE FILTER IN MCC IN LIEU OF SSSV STARTER (SOFT START) FOR EA. BP-1 & BP-2.
  - MOTOR TERMINATOR FOR EA. BP-1 & BP-2.
  - 3 #3 (TYPE XHHW) VFD OUTPUT WIRES IN LIEU OF 3 #3 (TYPE THHN/THWN) FOR EA. BP-1 & BP-2.

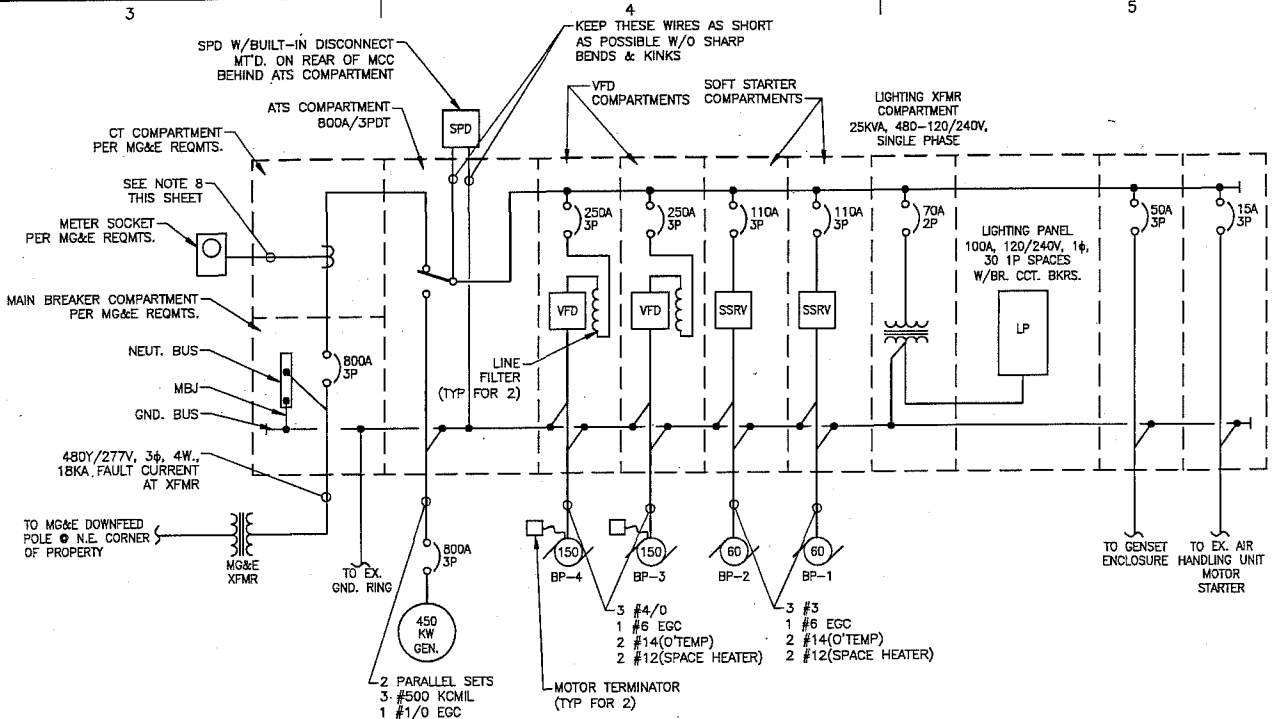

### REPLACEMENT MCC SINGLE LINE DIAGRAM

NO SCALE  
SEE REPLACEMENT MCC NOTES THIS SHEET

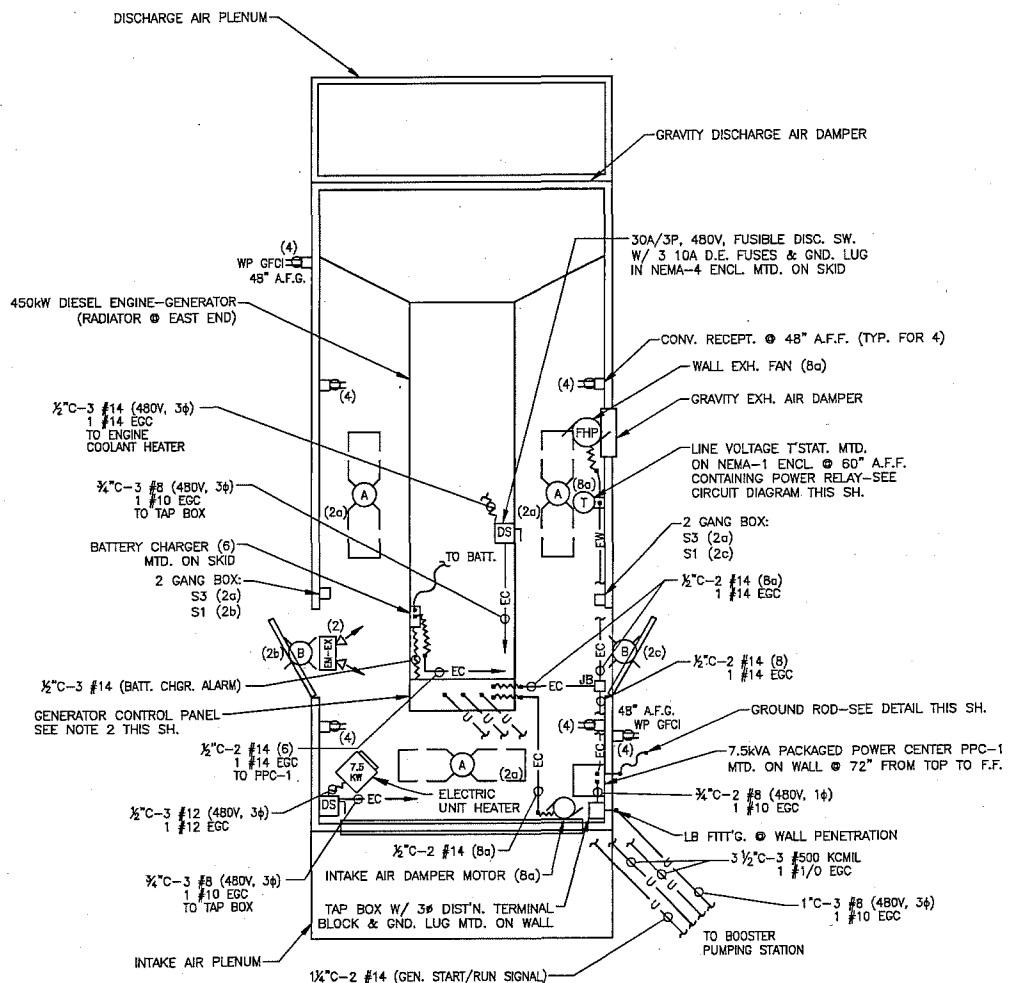

### GENERATOR SOUND ENCLOSURE PLAN

SCALE: 3/8" = 1'-0"

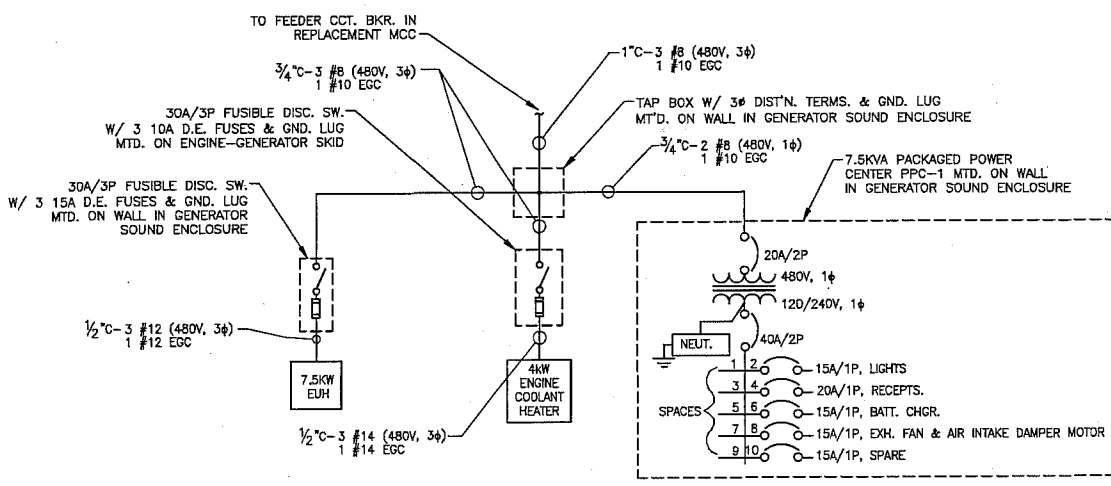

### GENERATOR SOUND ENCLOSURE SINGLE-LINE DISTRIBUTION DIAGRAM

NO SCALE

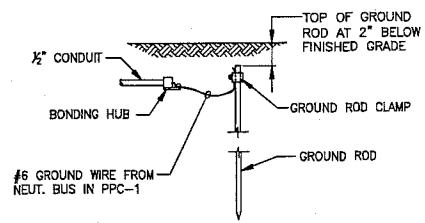

### GROUND ROD DETAIL

NO SCALE

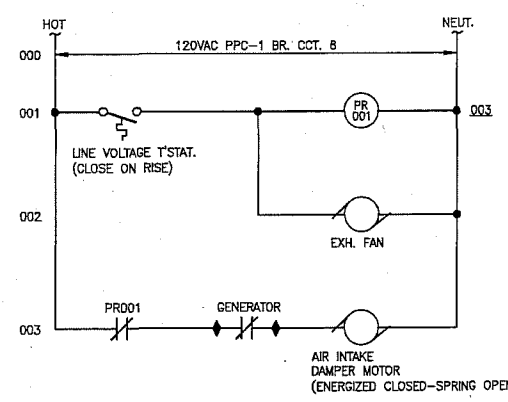

### GENERATOR SOUND ENCLOSURE EXH. FAN & AIR INTAKE DAMPER CIRCUIT DIAGRAM

NO SCALE

**BAXTER WOODMAN**  
Consulting Engineers

CONSULTANTS

NO.	DATE	DESCRIPTION

REFER TO EQUIPMENT MANUFACTURER'S SHOP DRAWING

PLAN SHEET DESIGNATION	
C	COVER
G	GENERAL
H	HAZARDOUS MATERIALS
C	CIVIL
S	LANDSCAPE
T	STRUCTURAL
A	ARCHITECTURAL
I	INSTRUMENTATION
O	EQUIPMENT
F	FIRE PROTECTION
P	PLUMBING
M	MECHANICAL
E	ELECTRICAL
T	TELECOMMUNICATIONS
R	RESOURCE

PROJECT NO:	140218
SCALE:	AS NOTED
DRAWING DATE:	12-1-2014
DESIGNED BY:	DJM
DRAWN BY:	RGE
CHECKED BY:	GSW

**MADISON WATER UTILITY**  
**MADISON, WISCONSIN**

**WATER SYSTEM IMPROVEMENTS**  
**BOOSTER PUMPING STATION 115**  
**UPGRADE**

SHEET TITLE

**ELECTRICAL DETAILS**

**E-3**

I:\CRYSTAL LAKE\MADUDY140218 - RPS 115\CADD\DRAWINGS\DWG\MADISON BOOSTER PUMPING STATION 115\SHEETS\ELECTRICAL\E-3 ELECTRICAL DETAILS.DWG E-3 ELECTRICAL DETAILS  
Plotted: 12/9/2014 3:15 PM By: 06ARGE  
Copyright © 2014, By Baxter & Woodman, Inc.  
State of Wisconsin - Professional Design Firm  
License No. - 484-011 - Expires 1-31-14







I:\CRYSTAL LAKE\MADUD\140218 - BPS 115\CADD\DRAWINGS\DWG\M-9 GENERATOR ENCLOSURE.DWG ELEVATIONS  
Plotted: 12/9/2014 9:28 AM By: 064RGE  
Copyright © 2014, By Baxter & Woodman, Inc.  
State of Wisconsin - Professional Design Firm  
License No. - 484-011 - Expires 1-31-14

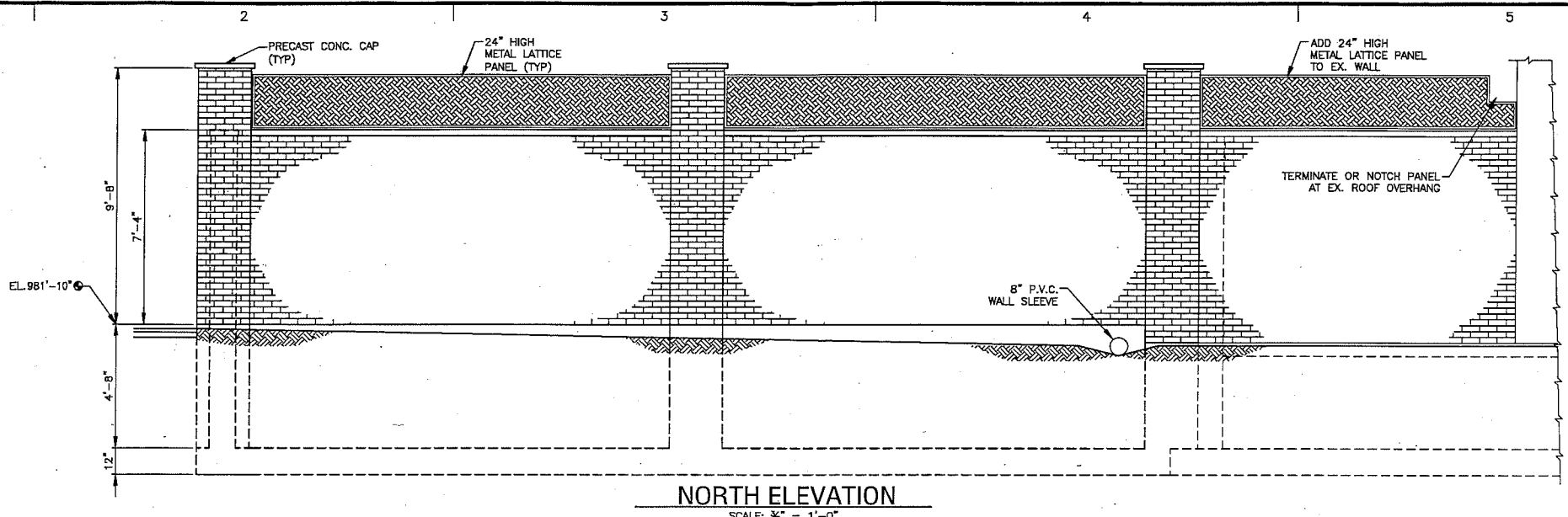

**NORTH ELEVATION**  
SCALE: 3/8" = 1'-0"

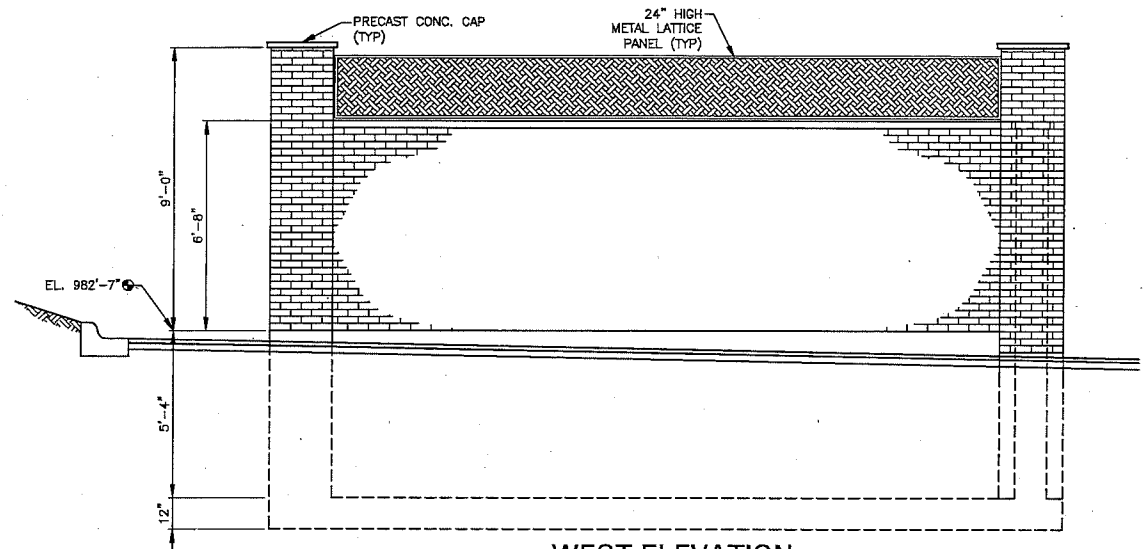

**WEST ELEVATION**  
SCALE: 3/8" = 1'-0"

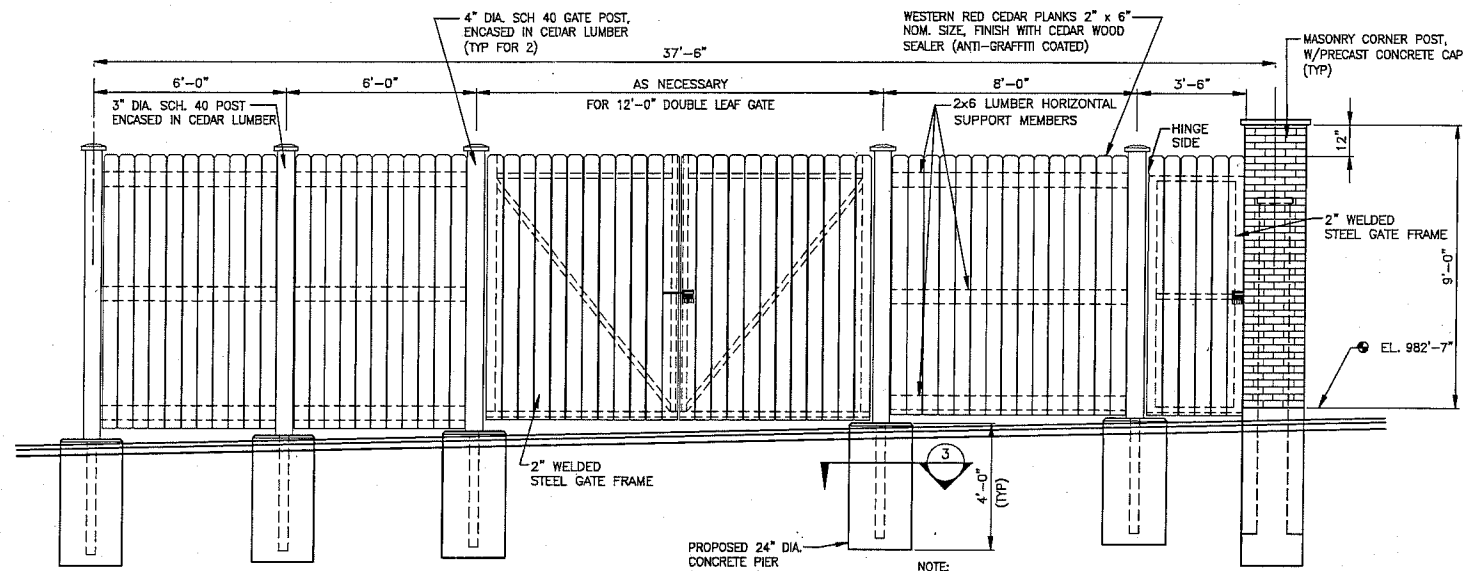

**SOUTH ELEVATION**  
SCALE: 3/8" = 1'-0"



CONSULTANTS

NO.	DATE	DESCRIPTION

REFER TO EQUIPMENT MANUFACTURER'S SHOP DRAWING

PLAN SHEET DESIGNATION

COVER  
 G - GENERAL  
 H - HAZARDOUS MATERIALS  
 C - CIVIL  
 L - LANDSCAPE  
 S - STRUCTURAL  
 A - ARCHITECTURAL  
 I - INSTRUMENTATION  
 Q - EQUIPMENT  
 F - FIRE PROTECTION  
 P - PLUMBING  
 M - MECHANICAL  
 E - ELECTRICAL  
 T - TELECOMMUNICATIONS  
 R - RESOURCE

PROJECT NO: 140218

SCALE: AS NOTED

DRAWING DATE: 12-1-2014

DESIGNED BY: GGG

DRAWN BY: RGE

CHECKED BY: GGG

CLIENT

**MADISON WATER UTILITY**  
**MADISON, WISCONSIN**

WATER SYSTEM IMPROVEMENTS  
 BOOSTER PUMPING STATION 115  
 UPGRADE

SHEET TITLE

**GENERATOR ENCLOSURE**  
**EXTERIOR ELEVATIONS**

**M-11**

I:\CRYSTAL LAKE\MADUD\140218 - BPS 115\CADD\DRAWINGS\DWG\140218-TOPO C3D.DWG PROPOSED  
 Plotted: 12/17/2014 3:06 PM By: 064RGE  
 Copyright © 2014, By Baxter & Woodman, Inc.  
 Wisconsin Professional Design Firm  
 License No. 484-011 Expires 1-31-14

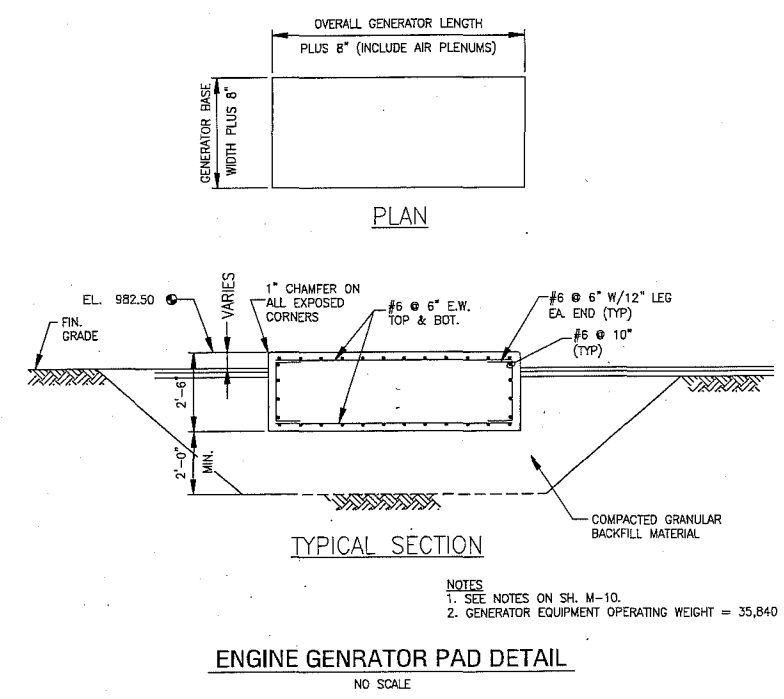
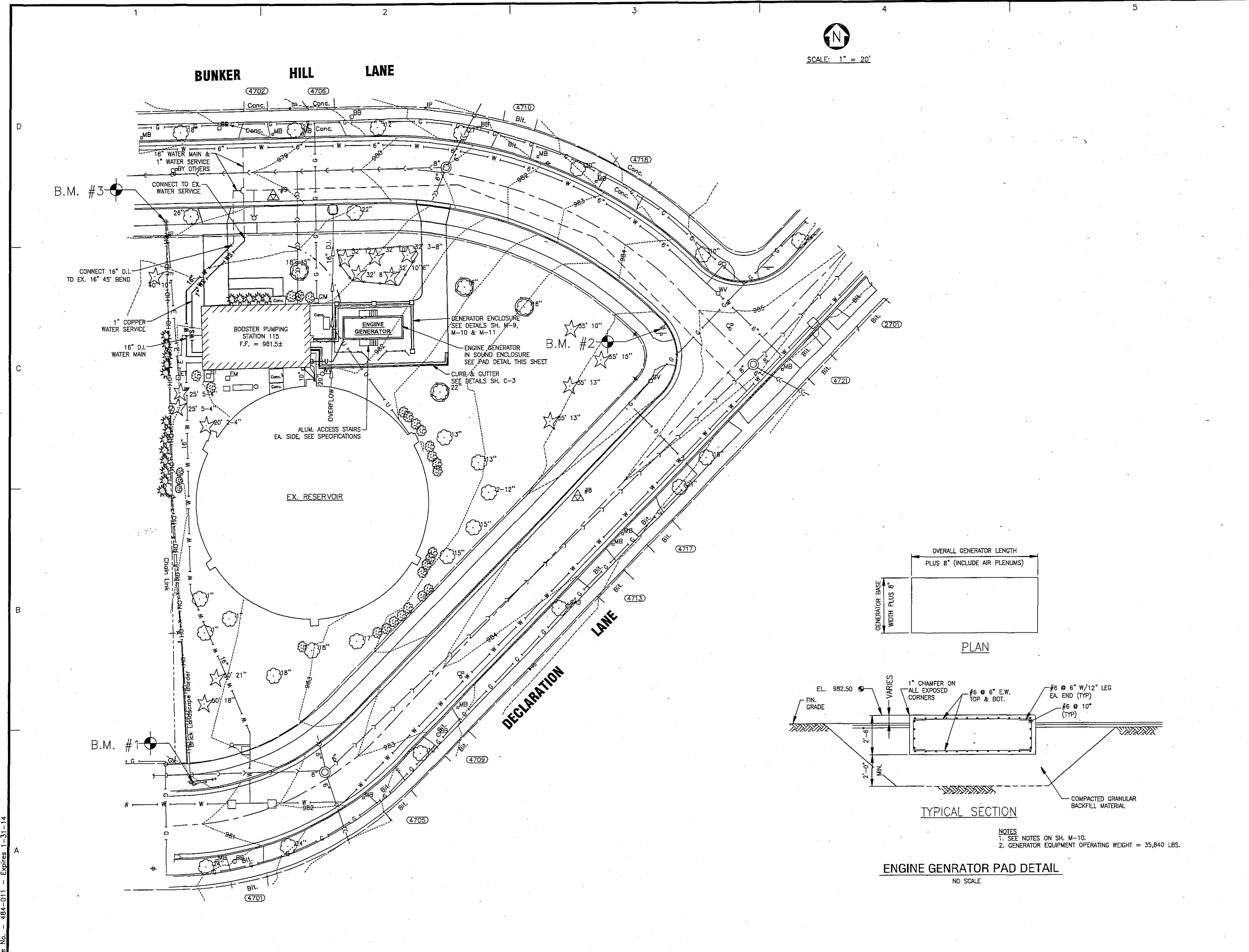

NOTES  
 1. SEE NOTES ON SH. M-10.  
 2. GENERATOR EQUIPMENT OPERATING WEIGHT = 35,840 LBS.

ENGINE GENERATOR PAD DETAIL  
 NO SCALE

**BAXTER & WOODMAN**  
 Consulting Engineers

CONSULTANTS

REVISIONS	DESCRIPTION
NO.	DATE

REFER TO EQUIPMENT MANUFACTURER'S SHOP DRAWING

PLAN SHEET DESIGNATION  
 COVER  
 G - GENERAL  
 H - HAZARDOUS MATERIALS  
 I - CIVIL  
 L - LANDSCAPE  
 S - STRUCTURAL  
 A - ARCHITECTURAL  
 I - INSTRUMENTATION  
 Q - EQUIPMENT  
 F - FIRE PROTECTION  
 P - PLUMBING  
 M - MECHANICAL  
 E - ELECTRICAL  
 T - TELECOMMUNICATIONS  
 R - RESOURCE

PROJECT NO: 140218  
 SCALE: AS NOTED  
 DRAWING DATE: 12-1-2014  
 DESIGNED BY: GDG  
 DRAWN BY: RGE  
 CHECKED BY: GDG

CLIENT  
**MADISON WATER UTILITY**  
**MADISON, WISCONSIN**  
 WATER SYSTEM IMPROVEMENTS  
 BOOSTER PUMPING STATION 115  
 UPGRADE

SHEET TITLE  
**SITE PIPING PLAN**

C-2

I:\CRYSTAL LAKE\MADISON\140218 - BPS 115\CADD\DRAWINGS\DWG\MADISON BOOSTER PUMPING STATION 115\SHEETS\ELECTRICAL\E-3 ELECTRICAL DETAILS.DWG E-3 ELECTRICAL DETAILS  
 Plotted: 12/17/2014 2:53 PM By: 064RCE  
 Copyright © 2014, By: Baxter & Woodman, Inc.  
 License No. 484-011 Expires 1-31-14

**REPLACEMENT MCC NOTES**

- ARRANGE LAYOUT OF REPLACEMENT MCC TO FACILITATE RE-USE OF EXISTING CONDUITS STUBBED THROUGH FLOOR FOR MG&E SERVICE WIRES, MAIN GND. WIRE, PUMP WIRES & CONTROL WIRES/CABLES.
- REPLACEMENT MCC DIMENSIONS NOT TO EXCEED 16'-0" LONG X 7'-6" HIGH X 1'-8" DEEP.
- LENGTHEN CONC. BASE TO ACCOMMODATE REPLACEMENT MCC.
- PROVIDE REPLACEMENT MCC W/BARRIERED CT COMPARTMENT IN COMPLIANCE W/MG&E REQUIREMENTS.
- PROVIDE REPLACEMENT MCC W/TOUCH SCREEN, PROGRAMMING PORT, PLC, UPS & SAME FUNCTIONALITY AS SYSTEMS PROVIDED AT OTHER MADISON WATER UTILITY SITES BY ALTRONEX CONTROL SYSTEMS DIVISION OF L.W. ALLEN, INC.
- PROVIDE MAIN CIRCUIT BREAKER IN REPLACEMENT MCC PER MG&E REQMTS. & W/MIN. INTERRUPT RATING OF 18KA & W/AUX. CONTACT SET SERIES CONNECTED TO ENGINE START/RUN CCT. TO PREVENT GENSET RUNNING WHEN IN AUTO MODE & MAIN CIRCUIT BREAKER IS OFF OR TRIPPED.
- ADJUST CARRIER FREQUENCY OF VFD'S TO BETWEEN 2 KHZ & 4 KHZ TO PRODUCE WHINE AT VFD'S & MOTORS AT A FREQUENCY BEYOND RANGE OF HUMAN HEARING.
- PROVIDE 1" CONDUIT RUNNING INSIDE REPLACEMENT MCC FROM CT COMPARTMENT TO METER SOCKET FOR WIRE HARNESS PROVIDED BY MG&E.
- PROVIDE CONTROLS COMPARTMENT AT RIGHT END (EAST END) OF MCC LINE-UP.
- IN ALTERNATIVE LUMP SUM BID PROVIDE THE FOLLOWING:
  - VFD & LINE FILTER IN MCC IN LIEU OF SSRV STARTER (SOFT START)
  - MOTOR TERMINATOR FOR EA, BP-1 & BP-2
  - 3 #3 (TYPE XHHW) VFD OUTPUT WIRES IN LIEU OF 3 #3 (TYPE THHN/THWN) FOR EA, BP-1 & BP-2
  - 2#14 (SPARE FOR USE AS OTEMP. WIRES WHEN EX. MOTOR IS REPLACED IN FUTURE W/ INVERTER DUTY RATED MOTOR) FOR EA, BP-1 & BP-2.

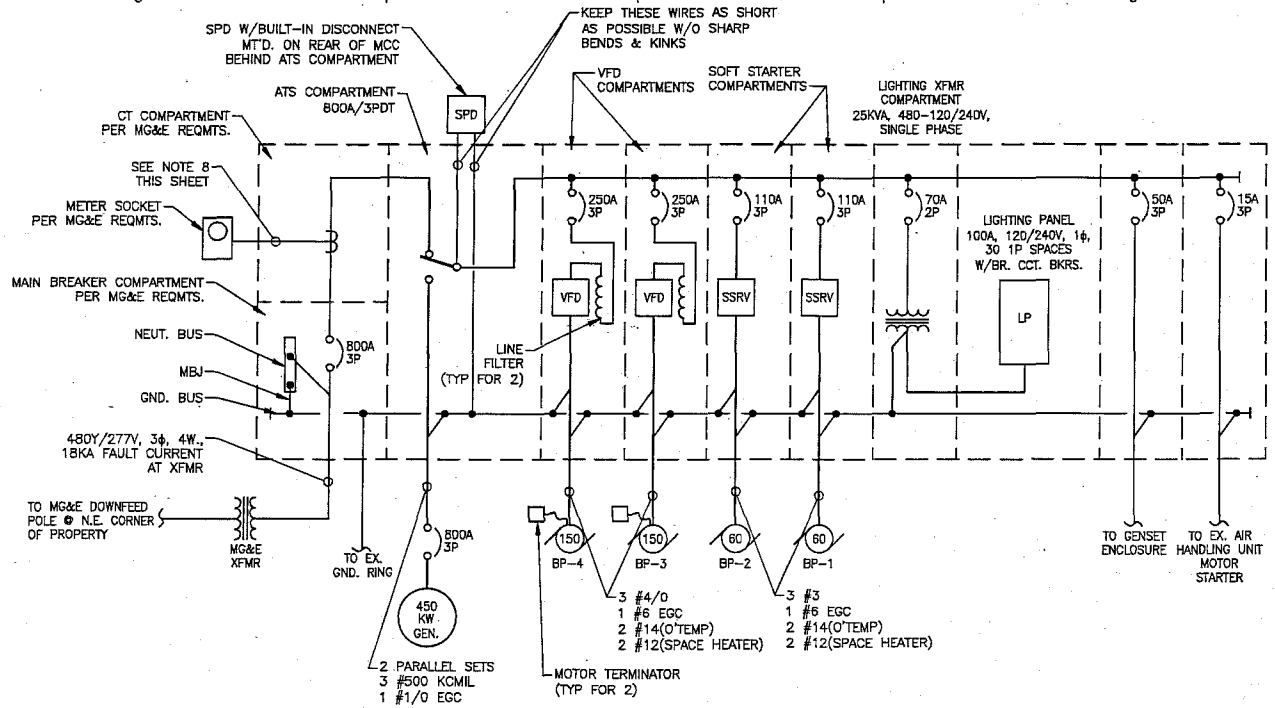

**REPLACEMENT MCC SINGLE LINE DIAGRAM**  
NO SCALE  
SEE REPLACEMENT MCC NOTES THIS SHEET

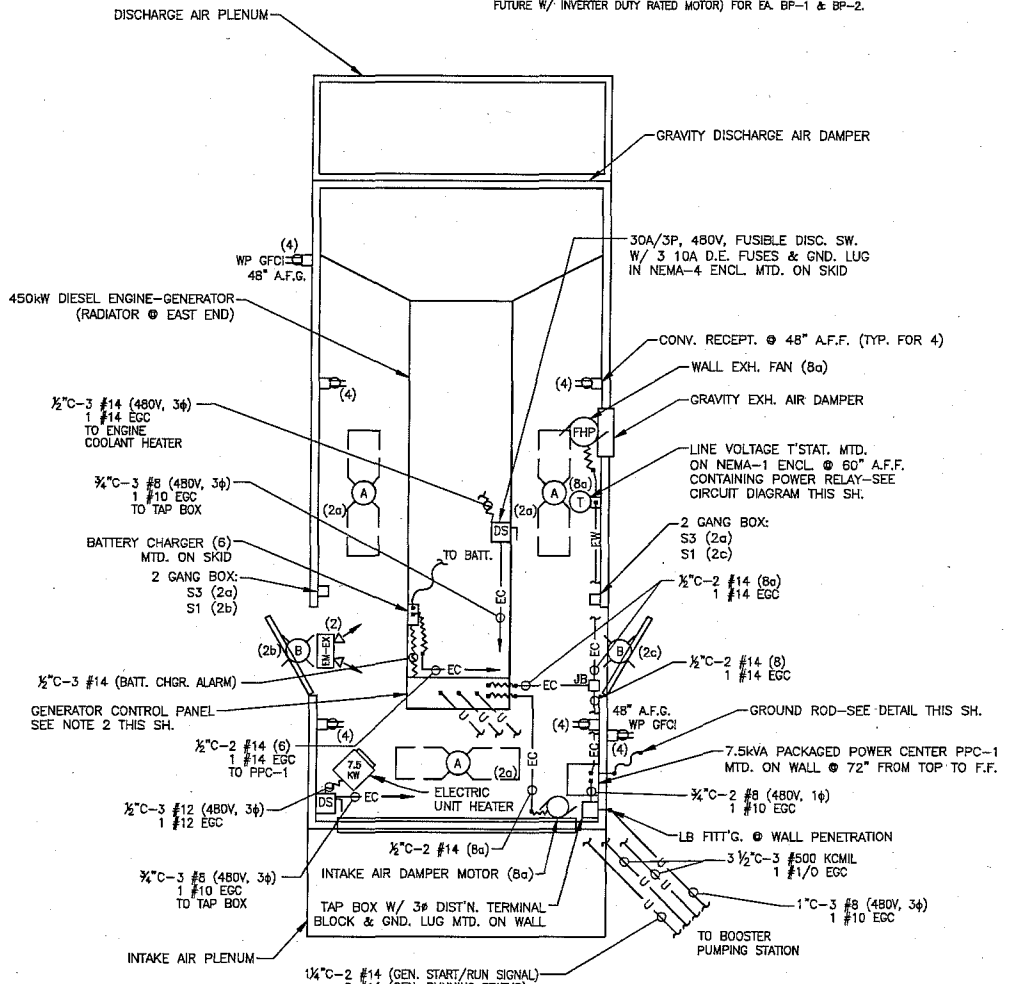

**GENERATOR SOUND ENCLOSURE PLAN**  
SCALE: 3/8" = 1'-0"

- NOTES**
- PROVIDE CONDUITS EXPOSED ON GENERATOR SOUND ENCLOSURE CEILING & WALLS (NOT SHOWN) AS REQ'D. FOR LIGHTING FIXTURES, RELATED SWITCHES & CONVENIENCE RECEPTACLES.
  - PROVIDE LIQUID-TIGHT FLEXIBLE METAL CONDUIT (12" MIN. LENGTH) ON EACH CONDUIT TERMINATION TO ENGINE-GENERATOR.

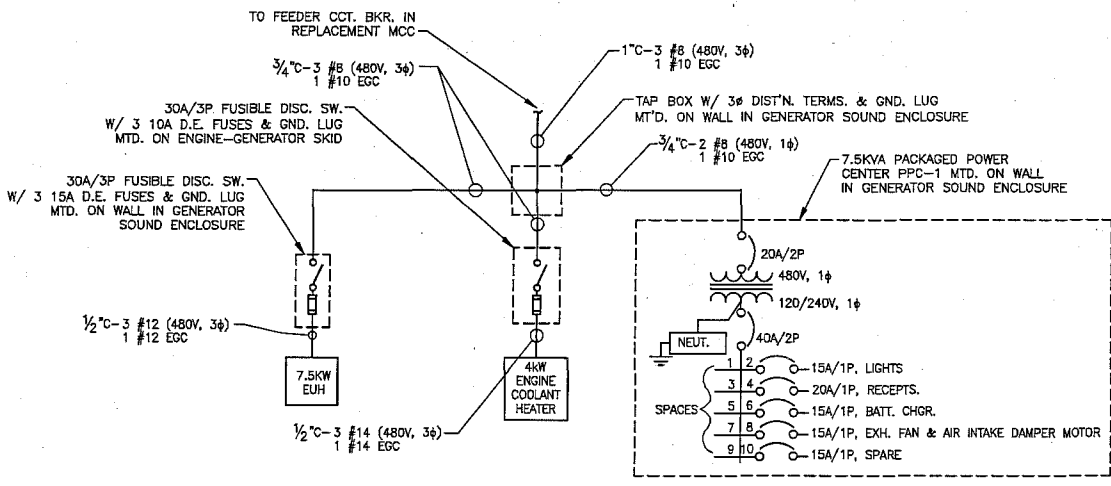

**GENERATOR SOUND ENCLOSURE SINGLE-LINE DISTRIBUTION DIAGRAM**  
NO SCALE

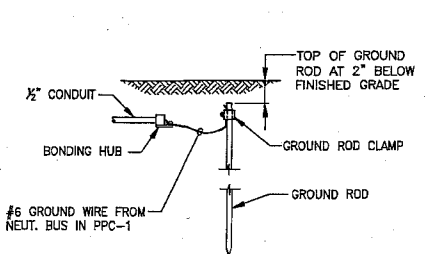

**GROUND ROD DETAIL**  
NO SCALE

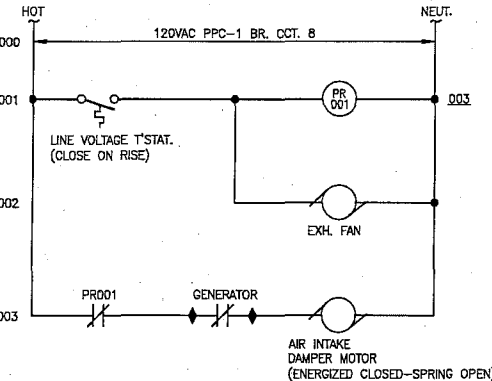

**GENERATOR SOUND ENCLOSURE EXH. FAN & AIR INTAKE DAMPER CIRCUIT DIAGRAM**  
NO SCALE

**BAXTER & WOODMAN**  
Consulting Engineers

CONSULTANTS

NO.	DATE	DESCRIPTION

REFER TO EQUIPMENT MANUFACTURER'S SHOP DRAWING

**PLAN SHEET DESIGNATION**

C	COVER
G	GENERAL
H	HAZARDOUS MATERIALS
I	INSTRUMENTATION
L	LANDSCAPE
S	STRUCTURAL
A	ARCHITECTURAL
E	ELECTRICAL
F	FIRE PROTECTION
M	MECHANICAL
T	TELECOMMUNICATIONS
R	RESOURCE

**CLIENT**

PROJECT NO:	140218
SCALE:	AS NOTED
DRAWING DATE:	12-1-2014
DESIGNED BY:	DJM
DRAWN BY:	RGE
CHECKED BY:	GSW

**MADISON WATER UTILITY  
MADISON, WISCONSIN**

**WATER SYSTEM IMPROVEMENTS  
BOOSTER PUMPING STATION 115  
UPGRADE**

**SHEET TITLE**  
**ELECTRICAL DETAILS**

**E-3**

REV





I:\CRYSTAL LAKE\MADUD\140218 - BPS 115\CADD\DRAWINGS\DWG\M-9 GENERATOR ENCLOSURE.DWG ELEVATIONS  
 Plotted: 12/18/2014 7:50 AM By: 064RGE  
 Copyright © 2014, By: Baxter & Woodman, Inc.  
 State of Wisconsin Professional Design Firm  
 License No. 184-011 Expires 1-31-14

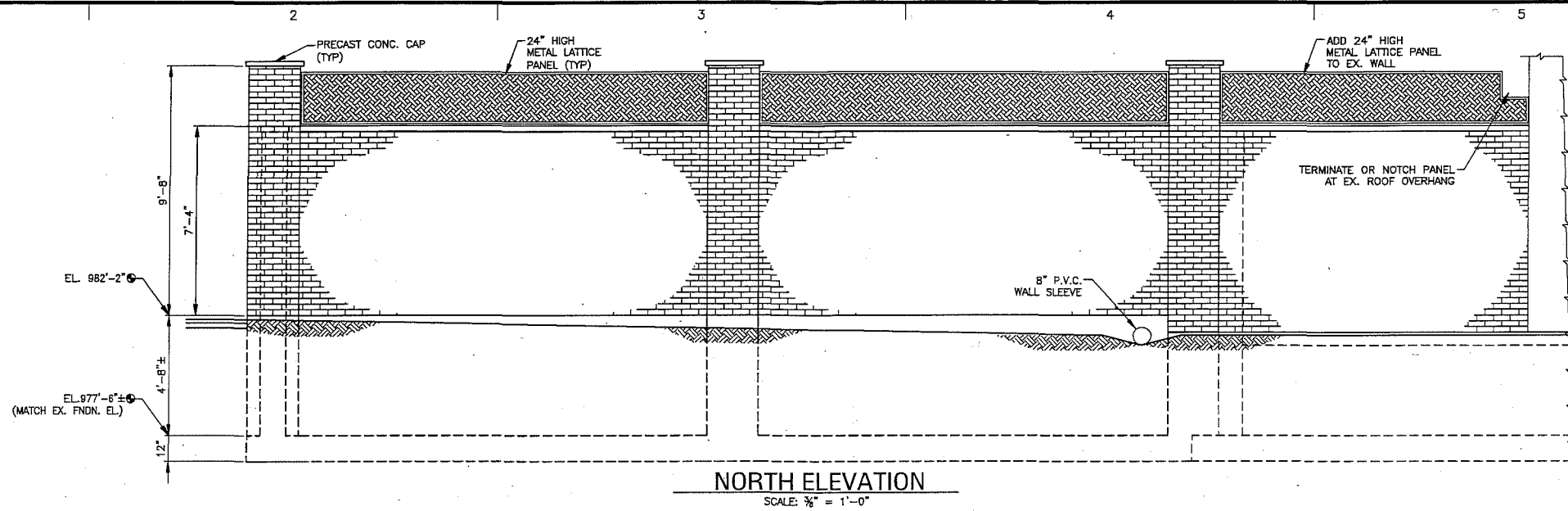

**NORTH ELEVATION**  
 SCALE: 3/8" = 1'-0"

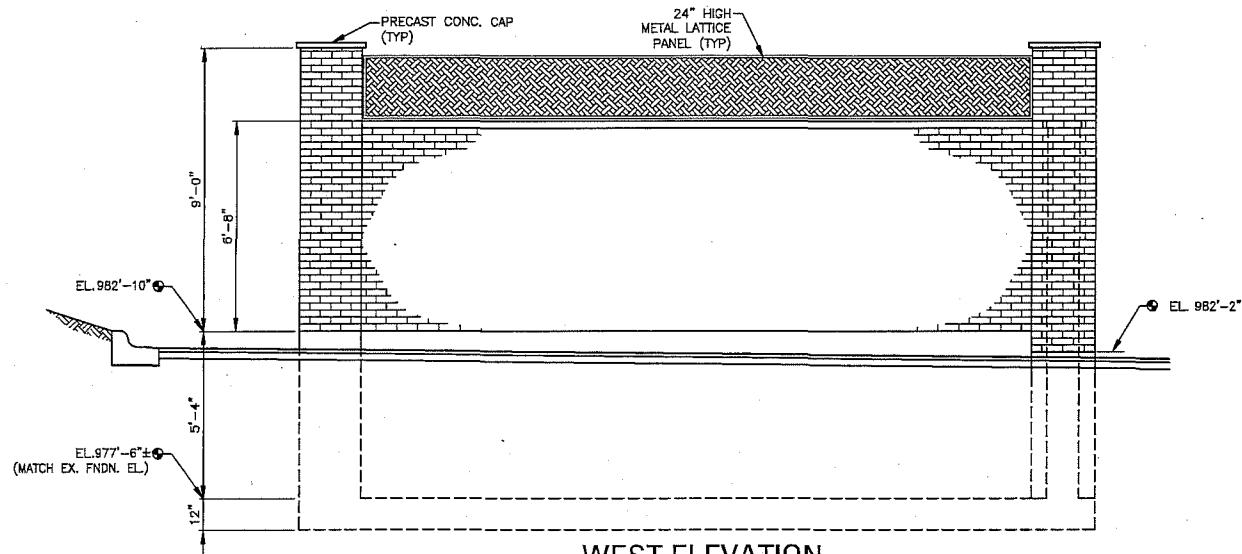

**WEST ELEVATION**  
 SCALE: 3/8" = 1'-0"

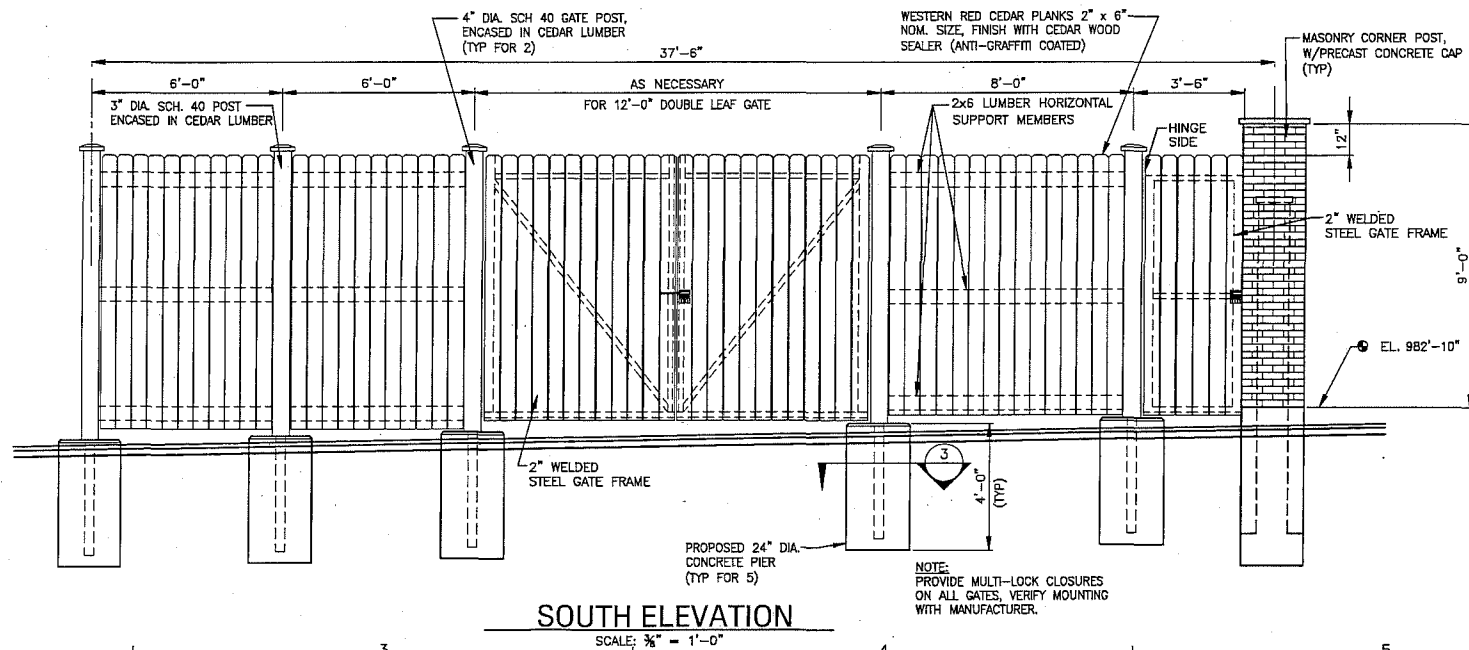

**SOUTH ELEVATION**  
 SCALE: 3/8" = 1'-0"



CONSULTANTS

NO.	DATE	DESCRIPTION

REFER TO EQUIPMENT MANUFACTURER'S SHOP DRAWING

PLAN SHEET DESIGNATION  
 COVER  
 G - GENERAL  
 H - HAZARDOUS MATERIALS  
 C - CIVIL  
 L - LANDSCAPE  
 S - STRUCTURAL  
 A - ARCHITECTURAL  
 I - INSTRUMENTATION  
 E - EQUIPMENT  
 F - FIRE PROTECTION  
 P - PLUMBING  
 M - MECHANICAL  
 T - ELECTRICAL  
 R - TELECOMMUNICATIONS  
 R - RESOURCE

PROJECT NO: 140218  
 SCALE: AS NOTED  
 DRAWING DATE: 12-1-2014  
 DESIGNED BY: GDG  
 DRAWN BY: RGE  
 CHECKED BY: GDG

CLIENT  
**MADISON WATER UTILITY**  
**MADISON, WISCONSIN**

WATER SYSTEM IMPROVEMENTS  
 BOOSTER PUMPING STATION 115  
 UPGRADE

SHEET TITLE  
**GENERATOR ENCLOSURE**  
**EXTERIOR ELEVATIONS**

**M-11**

REV



**SECTION E: BIDDERS ACKNOWLEDGEMENT**

**CONTRACT TITLE**

**CONTRACT NO.**

Bidder must state a Unit Price and Total Bid for each item. The Total Bid for each item must be the product of quantity, by Unit Price. The Grand Total must be the sum of the Total Bids for the various items. In case of multiplication errors or addition errors, the Grand Total with corrected multiplication and/or addition shall determine the Grand Total bid for each contract. The Unit Price and Total Bid must be entered numerically in the spaces provided. All words and numbers shall be written in ink.

1. The undersigned having familiarized himself/herself with the Contract documents, including Advertisement for Bids, Instructions to Bidders, Form of Proposal, City of Madison Standard Specifications for Public Works Construction - 2014 Edition thereto, Form of Agreement, Form of Bond, and Addenda issued and attached to the plans and specifications on file in the office of the City Engineer, hereby proposes to provide and furnish all the labor, materials, tools, and expendable equipment necessary to perform and complete in a workmanlike manner the specified construction on this project for the City of Madison; all in accordance with the plans and specifications as prepared by the City Engineer, including Addenda to the Contract Nos. ONE through \_\_\_\_\_ issued thereto, at the prices for said work as contained in this proposal. (Electronic bids submittals shall acknowledge addendum under Section E and shall not acknowledge here)
2. If awarded the Contract, we will initiate action within seven (7) days after notification or in accordance with the date specified in the contract to begin work and will proceed with diligence to bring the project to full completion within the number of work days allowed in the Contract or by the calendar date stated in the Contract.
3. The undersigned Bidder or Contractor certifies that he/she is not a party to any contract, combination in form of trust or otherwise, or conspiracy in restraint of trade or commerce or any other violation of the anti-trust laws of the State of Wisconsin or of the United States, with respect to this bid or contract or otherwise.
4. I hereby certify that I have met the Bid Bond Requirements as specified in Section 102.5. (IF BID BOND IS USED, IT SHALL BE SUBMITTED ON THE FORMS PROVIDED BY THE CITY. FAILURE TO DO SO MAY RESULT IN REJECTION OF THE BID).
5. I hereby certify that all statements herein are made on behalf of Midwest General - Mechanical (name of corporation, partnership, or person submitting bid) a corporation organized and existing under the laws of the State of Wisconsin a partnership consisting of \_\_\_\_\_; an individual trading as \_\_\_\_\_; of the City of \_\_\_\_\_ State of \_\_\_\_\_; that I have examined and carefully prepared this Proposal, from the plans and specifications and have checked the same in detail before submitting this Proposal; that I have fully authority to make such statements and submit this Proposal in (its, their) behalf; and that the said statements are true and correct.

  
SIGNATURE

President  
TITLE, IF ANY

Sworn and subscribed to before me this 7th day of January, 20 15.  
(Notary Public or other officer authorized to administer oaths)

My Commission Expires Jan. 29, 2016

Bidders shall not add any conditions or qualifying statements to this Proposal.

Wayne A. Bensch

# SECTION F: DISCLOSURE OF OWNERSHIP & BEST VALUE CONTRACTING

## BID TITLE CONTRACT NO. CONTRACT NUMBER

State of Wisconsin  
Department of Workforce Development  
Equal Rights Division  
Labor Standards Bureau

### Disclosure of Ownership

**Notice required under Section 15.04(1)(m), Wisconsin Statutes.** The statutory authority for the use of this form is prescribed in Sections 66.0903(12)(d) and 103.49(7)(d), Wisconsin Statutes. The use of this form is mandatory. The penalty for failing to complete this form is prescribed in Section 103.005(12), Wisconsin Statutes. Personal information you provide may be used for secondary purposes.

- (1) On the date a contractor submits a bid to or completes negotiations with a state agency or local governmental unit, on a project subject to Section 66.0903 or 103.49, Wisconsin Statutes, the contractor shall disclose to such state agency or local governmental unit the name of any "other construction business", which the contractor, or a shareholder, officer or partner of the contractor, owns or has owned within the preceding three (3) years.
- (2) The term "other construction business" means any business engaged in the erection, construction, remodeling, repairing, demolition, altering or painting and decorating of buildings, structures or facilities. It also means any business engaged in supplying mineral aggregate, or hauling excavated material or spoil as provided by Sections 66.0903(3), 103.49(2) and 103.50(2), Wisconsin Statutes.
- (3) This form must ONLY be filed, with the state agency or local governmental unit that will be awarding the contract, if **both (A) and (B) are met.**
  - (A) The contractor, or a shareholder, officer or partner of the contractor:
    - (1) Owns at least a 25% interest in the "other construction business", indicated below, on the date the contractor submits a bid or completes negotiations.
    - (2) Or has owned at least a 25% interest in the "other construction business" at any time within the preceding three (3) years.
  - (B) The Wisconsin Department of Workforce Development (DWD) has determined that the "other construction business" has failed to pay the prevailing wage rate or time and one-half the required hourly basic rate of pay, for hours worked in excess of the prevailing hours of labor, to any employee at any time within the preceding three (3) years.

#### Other Construction Business

Not Applicable

Name of Business

*NONE*

Street Address or P O Box

City

State

Zip Code

Name of Business

Street Address or P O Box

City

State

Zip Code

Name of Business

Street Address or P O Box

City

State

Zip Code

I hereby state under penalty of perjury that the information, contained in this document, is true and accurate according to my knowledge and belief.

Print the Name of Authorized Officer

*Charles Ludlow*

Signature of Authorized Officer

Date Signed

*1/8/15*

Name of Corporation, Partnership or Sole Proprietorship

*Midwest General & Mechanical Contractors*

Street Address or P O Box

*765 Bowers Rd*

City

*Highland*

State

*WI*

Zip Code

*53543*

**If you have any questions call (608) 266-0028**

ERD-7777-E (R. 09/2003)

**BID TITLE**  
**CONTRACT NO. CONTRACT NUMBER**

**Best Value Contracting**

1. The Contractor shall indicate the non-apprenticeable trades used on this contract.

*Midwest General & Mechanical Contractors*

2. Madison General Ordinance (M.G.O.), 33.07(7), does provide for some exemptions from the active apprentice requirement. Apprenticeable trades are those trades considered apprenticeable by the State of Wisconsin. Please check applicable box if you are seeking an exemption.

- Contractor has a total skilled workforce of four or less individuals in all apprenticeable trades combined.
- No available trade training program; The Contractor has been rejected by the only available trade training program, or there is no trade training program within 90 miles.
- Contractor is not using an apprentice due to having a journey worker on layoff status, provided the journey worker was employed by the contractor in the past six months.
- First-time Contractor on City of Madison Public Works contract requests a onetime exemption but intends to comply on all future contracts and is taking steps typical of a "good faith" effort.
- Contractor has been in business less than one year.
- Contractor doesn't have enough journeyman trade workers to qualify for a trade training program in that respective trade

3. The Contractor shall indicate on the following section which apprenticeable trades are to be used on this contract. Compliance with active apprenticeship, to the extent required by M.G.O. 33.07(7), shall be satisfied by documentation from an applicable trade training body; an apprenticeship contract with the Wisconsin Department of Workforce Development or a similar agency in another state; or the U.S Department of Labor. This documentation is required prior to the Contractor beginning work on the project site.

- The Contractor has reviewed the list and shall not use any apprenticeable trades on this project.

**LIST APPRENTICABLE TRADES** (check all that apply to your work to be performed on this contract)

- BRICKLAYER
- CARPENTER
- CEMENT MASON / CONCRETE FINISHER
- CEMENT MASON (HEAVY HIGHWAY)
- CONSTRUCTION CRAFT LABORER
- DATA COMMUNICATION INSTALLER
- ELECTRICIAN
- ENVIRONMENTAL SYSTEMS TECHNICIAN / HVAC SERVICE TECH/HVAC INSTALL / SERVICE
- GLAZIER
- HEAVY EQUIPMENT OPERATOR / OPERATING ENGINEER
- INSULATION WORKER (HEAT & FROST)
- IRON WORKER
- IRON WORKER (ASSEMBLER, METAL BLDGS)
- PAINTER & DECORATOR
- PLASTERER
- PLUMBER
- RESIDENTIAL ELECTRICIAN
- ROOFER & WATER PROOFER
- SHEET METAL WORKER
- SPRINKLER FITTER
- STEAMFITTER
- STEAMFITTER (REFRIGERATION)
- STEAMFITTER (SERVICE)
- TAPER & FINISHER
- TELECOMMUNICATIONS (VOICE, DATA & VIDEO) INSTALLER-TECHNICIAN
- TILE SETTER

CONTRACT NO. ERROR! REFERENCE SOURCE NOT FOUND.

**Small Business Enterprise Compliance Report**

This information may be submitted electronically through Bid Express or submitted with bid in sealed envelope.

**Cover Sheet**

Prime Bidder Information

Company: Midwest General & Mechanical Contractors

Address: 765 Bowers Rd PO 305 Highland WI 53543

Telephone Number: 608 943 8541 Fax Number: 943-8553

Contact Person/Title: Chuck Zwolanek President

Prime Bidder Certification

I, Charles Zwolanek Name President Title of

Midwest General & Mechanical Contractors Company certify that the information

contained in this SBE Compliance Report is true and correct to the best of my knowledge and belief.

William Zwolanek  
Witness' Signature

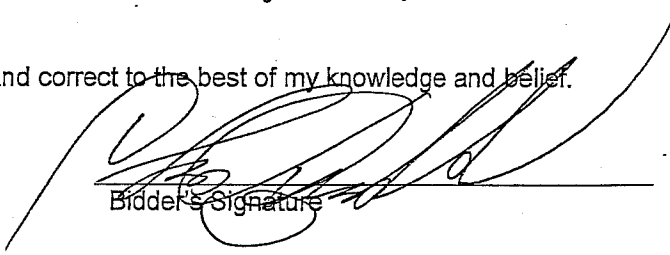
  
Bidder's Signature

1/8/15  
Date



## Section B: Lump Sum Proposal

BASE BID: All civil, mechanical, electrical and associated work for the proposed upgrades to BPS 115, as noted in Contract documents. \*

\$ 1899 585<sup>00</sup>

## Section B: Alternate 1

Item Code	Description	Quantity	Units	Fixed	Unit Price	Extended Quantity
-----------	-------------	----------	-------	-------	------------	-------------------

Alternate: Owner-agency may award independently from entire bid.  
 Component is not included in bid total.

ALTERNATIVE ADD: ADD two VFDs and associated work, wiring and controls in lieu of RVSS for existing 60 Hp Booster Pumps No. 1 and No. 2, as described in Note 10 on Sheet E-3.  
 (Note this ADD amount will not be considered in determining the

90002 lowest responsible and responsive bidder.)

1 Item

1 Lump Sum No

\$ 22,997 <sup>00</sup>	<del>22,997</del>
22,997 <sup>00</sup>	22,997 <sup>00</sup>





## SECTION G: BID BOND

KNOW ALL MEN BY THESE PRESENT, THAT Midwest General & Mechanical Contractors, Inc. (a corporation of the State of Wisconsin) (Individual), (partnership), hereinafter referred to as the "Principal") and Granite Re, Inc., a corporation of the State of Oklahoma (hereinafter referred to as the "Surety") and licensed to do business in the State of Wisconsin, are held and firmly bound unto the City of Madison, (hereinafter referred to as the "Obligee"), in the sum of five per cent (5%) of the amount of the total bid or bids of the Principal herein accepted by the Obligee, for the payment of which the Principal and the Surety bind themselves, their heirs, executors, administrators, successors and assigns, jointly and severally, firmly by these presents.

The conditions of this obligation are such that, whereas the Principal has submitted, to the City of Madison a certain bid, including the related alternate, and substitute bids attached hereto and hereby made a part hereof, to enter into a contract in writing for the construction of:

### BOOSTER PUMPING STATION 115 UPGRADES CONTRACT NO. 7411

1. If said bid is rejected by the Obligee, then this obligation shall be void.
2. If said bid is accepted by the Obligee and the Principal shall execute and deliver a contract in the form specified by the Obligee (properly completed in accordance with said bid) and shall furnish a bond for his/her faithful performance of said contract, and for the payment of all persons performing labor or furnishing materials in connection therewith, and shall in all other respects perform the agreement created by the acceptance of said bid, then this obligation shall be void.

If said bid is accepted by the Obligee and the Principal shall fail to execute and deliver the contract and the performance and payment bond noted in 2. above executed by this Surety, or other Surety approved by the City of Madison, all within the time specified or any extension thereof, the Principal and Surety agree jointly and severally to forfeit to the Obligee as liquidated damages the sum mentioned above, it being understood that the liability of the Surety for any and all claims hereunder shall in no event exceed the sum of this obligation as stated, and it is further understood that the Principal and Surety reserve the right to recover from the Obligee that portion of the forfeited sum which exceed the actual liquidated damages incurred by the Obligee.

The Surety, for value received, hereby stipulates and agrees that the obligations of said Surety and its bond shall be in no way impaired or affected by an extension of the time within which the Obligee may accept such bid, and said Surety does hereby waive notice of any such extension.

IN WITNESS WHEREOF, the Principal and the Surety have hereunto set their hands and seals, and such of them as are corporations have caused their corporate seals to be hereto affixed and these presents to be signed by their proper officers, on the day and year set forth below.

Seal Midwest General & Mechanical Contractors, Inc. 1/8/15  
Principal Date

By: [Signature]

Granite Re, Inc.  
Name of Surety

By: [Signature] 12/08/2015  
Robert Downey, Attorney-in-Fact Date

This certifies that I have been duly licensed as an agent for the above company in Wisconsin under License No. 2587534 for the year 2015, and appointed as attorney in fact with authority to execute this bid bond and the payment and performance bond referred to above, which power of attorney has not been revoked.

01/08/2015 J. Ryan Bonding, Inc.  
Date Agent  
P.O. Box 465  
Address  
Hudson, WI 54016  
City, State and Zip Code  
800-535-0006  
Telephone Number

**NOTE TO SURETY & PRINCIPAL**

The bid submitted which this bond guarantees may be rejected if the following instrument is not attached to this bond:

Power of Attorney showing that the agent of Surety is currently authorized to execute bonds on behalf of the Surety, and in the amounts referenced above.

**GRANITE RE, INC.**  
**GENERAL POWER OF ATTORNEY**

**Know all Men by these Presents:**

That GRANITE RE, INC., a corporation organized and existing under the laws of the State of OKLAHOMA and having its principal office at the City of OKLAHOMA CITY in the State of OKLAHOMA does hereby constitute and appoint:

MICHAEL J. DOUGLAS; CHRIS STEINAGEL; CHRISTOPHER M. KEMP; KARLA HEFFRON; ROBERT DOWNEY; CONNIE SMITH its true and lawful Attorney-in-Fact(s) for the following purposes, to wit:



To sign its name as surety to, and to execute, seal and acknowledge any and all bonds, and to respectively do and perform any and all acts and things set forth in the resolution of the Board of Directors of the said GRANITE RE, INC. a certified copy of which is hereto annexed and made a part of this Power of Attorney; and the said GRANITE RE, INC. through us, its Board of Directors, hereby ratifies and confirms all and whatsoever the said:

MICHAEL J. DOUGLAS; CHRIS STEINAGEL; CHRISTOPHER M. KEMP; KARLA HEFFRON; ROBERT DOWNEY; CONNIE SMITH may lawfully do in the premises by virtue of these presents.

In Witness Whereof, the said GRANITE RE, INC. has caused this instrument to be sealed with its corporate seal, duly attested by the signatures of its President and Secretary/Treasurer, this 3<sup>rd</sup> day of July, 2013.

STATE OF OKLAHOMA )  
                                  ) SS:  
COUNTY OF OKLAHOMA )

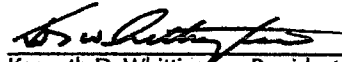

  
\_\_\_\_\_  
Kenneth D. Whittington, President  
  
\_\_\_\_\_  
Kyle P. McDonald, Treasurer

On this 3<sup>rd</sup> day of July, 2013, before me personally came Kenneth D. Whittington, President of the GRANITE RE, INC. Company and Kyle P. McDonald, Secretary/Treasurer of said Company, with both of whom I am personally acquainted, who being by me severally duly sworn, said, that they, the said Kenneth D. Whittington and Kyle P. McDonald were respectively the President and the Secretary/Treasurer of GRANITE RE, INC., the corporation described in and which executed the foregoing Power of Attorney; that they each knew the seal of said corporation; that the seal affixed to said Power of Attorney was such corporate seal, that it was so fixed by order of the Board of Directors of said corporation, and that they signed their name thereto by like order as President and Secretary/Treasurer, respectively, of the Company.

My Commission Expires:  
August 8, 2017  
Commission #: 01013257



  
\_\_\_\_\_  
Kathleen E. Carlson  
Notary Public

**GRANITE RE, INC.**  
Certificate

THE UNDERSIGNED, being the duly elected and acting Secretary/Treasurer of Granite Re, Inc., an Oklahoma Corporation, HEREBY CERTIFIES that the following resolution is a true and correct excerpt from the July 15, 1987, minutes of the meeting of the Board of Directors of Granite Re, Inc. and that said Power of Attorney has not been revoked and is now in full force and effect.

"RESOLVED, that the President, any Vice President, the Secretary, and any Assistant Vice President shall each have authority to appoint individuals as attorneys-in-fact or under other appropriate titles with authority to execute on behalf of the company fidelity and surety bonds and other documents of similar character issued by the Company in the course of its business. On any instrument making or evidencing such appointment, the signatures may be affixed by facsimile. On any instrument conferring such authority or on any bond or undertaking of the Company, the seal, or a facsimile thereof, may be impressed or affixed or in any other manner reproduced; provided, however, that the seal shall not be necessary to the validity of any such instrument or undertaking."

IN WITNESS WHEREOF, the undersigned has subscribed this Certificate and affixed the corporate seal of the Corporation this

6 day of JAN, 2014.



  
\_\_\_\_\_  
Kyle P. McDonald, Secretary/Treasurer



## SECTION H: AGREEMENT

THIS AGREEMENT made this 3d day of MARCH in the year Two Thousand and Fifteen between MIDWEST GENERAL & MECHANICAL CONTRACTORS, INC. hereinafter called the Contractor, and the City of Madison, Wisconsin, hereinafter called the City.

WHEREAS, the Common Council of the said City of Madison under the provisions of a resolution adopted FEBRUARY 24, 2015, and by virtue of authority vested in the said Council, has awarded to the Contractor the work of performing certain construction.

NOW, THEREFORE, the Contractor and the City, for the consideration hereinafter named, agree as follows:

1. **Scope of Work.** The Contractor shall, perform the construction, execution and completion of the following listed complete work or improvement in full compliance with the Plans; Specifications, Standard Specifications, Supplemental Specifications, Special Provisions and contract; perform all items of work covered or stipulated in the proposal; perform all altered or extra work; and shall furnish, unless otherwise provided in the contract, all materials, implements, machinery, equipment, tools, supplies, transportation, and labor necessary to the prosecution and completion of the work or improvements:

### BOOSTER PUMP STATION 115 UPGRADE CONTRACT NO. 7411

2. **Completion Date/Contract Time.** Construction work must begin within seven (7) calendar days after the date appearing on mailed written notice to do so shall have been sent to the Contractor and shall be carried on at a rate so as to secure full completion SEE SPECIAL PROVISIONS, the rate of progress and the time of completion being essential conditions of this Agreement.
3. **Contract Price.** The City shall pay to the Contractor at the times, in the manner and on the conditions set forth in said specifications, the sum of NINE HUNDRED TWENTY-TWO THOUSAND FIVE HUNDRED EIGHTY-TWO (\$922,582.00) Dollars being the amount bid by such Contractor and which was awarded to him/her as provided by law.
4. **Wage Rates for Employees of Public Works Contractors**

**General and Authorization.** The Contractor shall compensate its employees at the prevailing wage rate in accordance with section 66.0903, Wis. Stats., DWD 290 of the Wisconsin Administrative Code and as hereinafter provided unless otherwise noted in Section D: Special Provisions, Subsection 102.10 – Minimum Rate of Wage Scale.

"Public Works" shall include building or work involving the erection, construction, remodeling, repairing or demolition of buildings, parking lots, highways, streets, bridges, sidewalks, street lighting, traffic signals, sanitary sewers, water mains and appurtenances, storm sewers, and the grading and landscaping of public lands.

"Building or work" includes construction activity as distinguished from manufacturing, furnishing of materials, or servicing and maintenance work, except for the delivery of mineral aggregate such as sand, gravel, bituminous asphaltic concrete or stone which is incorporated into the work under contract with the City by depositing the material directly in final place from transporting vehicle.

"Erection, construction, remodeling, repairing" means all types of work done on a particular building or work at the site thereof in the construction or development of the project, including without limitation, erecting, construction, remodeling, repairing, altering, painting, and decorating, the transporting of materials and supplies to or from the building or work done by the employees of the Contractor, Subcontractor, or Agent thereof, and the manufacturing or furnishing of

materials, articles, supplies or equipment on the site of the building or work, by persons employed by the Contractor, Subcontractor, or Agent thereof.

"Employees working on the project" means laborers, workers, and mechanics employed directly upon the site of work.

"Laborers, Workers, and Mechanics" include pre-apprentices, helpers, trainees, learners and properly registered and indentured apprentices but exclude clerical, supervisory, and other personnel not performing manual labor.

**Establishment of Wage Rates.** The Department of Public Works shall periodically obtain a current schedule of prevailing wage rates from DWD. The schedule shall be used to establish the City of Madison Prevailing Wage Rate Schedule for Public Works Construction (prevailing wage rate). The Department of Public Works may include known increases to the prevailing wage rate which can be documented and are to occur on a future specific date. The prevailing wage rate shall be included in public works contracts subsequently negotiated or solicited by the City. Except for known increases contained within the schedule, the prevailing wage rate shall not change during the contract. The approved wage rate is attached hereto.

**Workforce Profile.** The Contractor shall, at the time of signature of the contract, notify the City Engineer in writing of the names and classifications of all the employees of the Contractor, Subcontractors, and Agents proposed for the work. In the alternative, the Contractor shall submit in writing the classifications of all the employees of the Contractor, Subcontractors and Agents and the total number of hours estimated in each classification for the work. This workforce profile(s) shall be reviewed by the City Engineer who may, within ten (10) days, object to the workforce profile(s) as not being reflective of that which would be required for the work. The Contractor may request that the workforce profile, or a portion of the workforce profile, be submitted after the signature of the contract but at least ten (10) days prior to the work commencing. Any costs or time loss resulting from modifications to the workforce profile as a result of the City Engineer's objections shall be the responsibility of the Contractor.

**Payrolls and Records.** The Contractor shall keep weekly payroll records setting forth the name, address, telephone number, classification, wage rate and fringe benefit package of all the employees who work on the contract, including the employees of the Contractor's subcontractors and agents. Such weekly payroll records must include the required information for all City contracts and all other contracts on which the employee worked during the week in which the employee worked on the contract. The Contractor shall also keep records of the individual time each employee worked on the project and for each day of the project. Such records shall also set forth the total number of hours of overtime credited to each such employee for each day and week and the amount of overtime pay received in that week. The records shall set forth the full weekly wages earned by each employee and the actual hourly wage paid to the employee.

The Contractor shall submit the weekly payroll records, including the records of the Contractor's subcontractors and agents, to the City Engineer for every week that work is being done on the contract. The submittal shall be within twenty-one (21) calendar days of the end of the Contractor's weekly pay period.

Employees shall receive the full amounts accrued at the time of the payment, computed at rates not less than those stated in the prevailing wage rate and each employee's rate shall be determined by the work that is done within the trade or occupation classification which should be properly assigned to the employee.

An employee's classification shall not be changed to a classification of a lesser rate during the contract. If, during the term of the contract, an employee works in a higher pay classification than the one which was previously properly assigned to the employee, then that employee shall be considered to be in the higher pay classification for the balance of the contract, receive the appropriate higher rate of pay, and she/he shall not receive a lesser rate during the balance of the

contract. For purposes of clarification, it is noted that there is a distinct difference between working in a different classification with higher pay and doing work within a classification that has varying rates of pay which are determined by the type of work that is done within the classification. For example, the classification "Operating Engineer" provides for different rates of pay for various classes of work and the Employer shall compensate an employee classified as an "Operating Engineer" based on the highest class of work that is done in one day. Therefore, an "Operating Engineer's" rate may vary on a day to day basis depending on the type of work that is done, but it will never be less than the base rate of an "Operating Engineer". Also, as a matter of clarification, it is recognized that an employee may work in a higher paying classification merely by chance and without prior intention, calculation or design. If such is the case and the performance of the work is truly incidental and the occurrence is infrequent, inconsequential and does not serve to undermine the single classification principle herein, then it may not be required that the employee be considered to be in the higher pay classification and receive the higher rate of pay for the duration of the contract. However, the Contractor is not precluded or prevented from paying the higher rate for the limited time that an employee performs work that is outside of the employee's proper classification.

Questions regarding an employee's classification, rate of pay or rate of pay within a classification, shall be resolved by reference to the established practice that predominates in the industry and on which the trade or occupation rate/classification is based. Rate of pay and classification disputes shall be resolved by relying upon practices established by collective bargaining agreements and guidelines used in such determination by appropriate recognized trade unions operating within the City of Madison.

The Contractor, its Subcontractors and Agents shall submit to interrogation regarding compliance with the provisions of this ordinance.

Mulcting of the employees by the Contractor, Subcontractor, and Agents on Public Works contracts, such as by kickbacks or other devices, is prohibited. The normal rate of wage of the employees of the Contractor, Subcontractor, and Agents shall not be reduced or otherwise diminished as a result of payment of the prevailing wage rate on a public works contract.

**Hourly contributions.** Hourly contributions shall be determined in accordance with the prevailing wage rate and with DWD. 290.01(10), Wis. Admin. Code.

**Apprentices and Subjourney persons.** Apprentices and sub journeypersons performing work on the project shall be compensated in accordance with the prevailing wage rate and with DWD 290.02, and 290.025, respectively, Wis. Admin. Code.

**Straight Time Wages.** The Contractor may pay straight time wages as determined by the prevailing wage rate and DWD 290.04, Wis. Admin. Code.

**Overtime Wages.** The Contractor shall pay overtime wages as required by the prevailing wage rate and DWD 290.05, Wis. Admin. Code.

**Posting of Wage Rates and Hours.** A clearly legible copy of the prevailing wage rate, together with the provisions of Sec. 66.0903(10)(a) and (11)(a), Wis. Stats., shall be kept posted in at least one conspicuous and easily accessible place at the project site by the Contractor and such notice shall remain posted during the full time any laborers, workers or mechanics are employed on the contract.

**Evidence of Compliance by Contractor.** Upon completion of the contract, the Contractor shall file with the Department of Public Works an affidavit stating:

- a. That the Contractor has complied fully with the provisions and requirements of Sec. 66.0903(3), Wis. Stats., and Chapter DWD 290, Wis. Admin. Code; the Contractor has received evidence of compliance from each of the agents and subcontractors; and the

names and addresses of all of the subcontractors and agents who worked on the contract.

- b. That full and accurate records have been kept, which clearly indicate the name and trade or occupation of every laborer, worker or mechanic employed by the Contractor in connection with work on the project. The records shall show the number of hours worked by each employee and the actual wages paid therefore; where these records will be kept and the name, address and telephone number of the person who will be responsible for keeping them. The records shall be retained and made available for a period of at least three (3) years following the completion of the project of public works and shall not be removed without prior notification to the municipality.

**Evidence of Compliance by Agent and Subcontractor.** Each agent and subcontractor shall file with the Contractor, upon completion of their portion of the work on the contract an affidavit stating that all the provisions of Sec. 66.0903(3), Wis. Stats., have been fully complied with and that full and accurate records have been kept, which clearly indicate the name and trade or occupation of every laborer, worker or mechanic employed by the Contractor in connection with work on the project. The records shall show the number of hours worked by each employee and the actual wages paid therefore; where these records shall be kept and the name, address and telephone number of the person who shall be responsible for keeping them. The records shall be retained and made available for a period of at least three (3) years following the completion of the project of public works and shall not be removed without prior notification to the municipality.

**Failure to Comply with the Prevailing Wage Rate.** If the Contractor fails to comply with the prevailing wage rate, she/he shall be in default on the contract.

5. **Affirmative Action.** In the performance of the services under this Agreement the Contractor agrees not to discriminate against any employee or applicant because of race, religion, marital status, age, color, sex, disability, national origin or ancestry, income level or source of income, arrest record or conviction record, less than honorable discharge, physical appearance, sexual orientation, gender identity, political beliefs, or student status. The Contractor further agrees not to discriminate against any subcontractor or person who offers to subcontract on this contract because of race, religion, color, age, disability, sex, sexual orientation, gender identity or national origin.

The Contractor agrees that within thirty (30) days after the effective date of this agreement, the Contractor will provide to the City Affirmative Action Division certain workforce utilization statistics, using a form to be furnished by the City.

If the contract is still in effect, or if the City enters into a new agreement with the Contractor, within one year after the date on which the form was required to be provided, the Contractor will provide updated workforce information using a second form, also to be furnished by the City. The second form will be submitted to the City Affirmative Action Division no later than one year after the date on which the first form was required to be provided.

The Contractor further agrees that, for at least twelve (12) months after the effective date of this contract, it will notify the City Affirmative Action Division of each of its job openings at facilities in Dane County for which applicants not already employees of the Contractor are to be considered. The notice will include a job description, classification, qualifications and application procedures and deadlines. The Contractor agrees to interview and consider candidates referred by the Affirmative Action Division if the candidate meets the minimum qualification standards established by the Contractor, and if the referral is timely. A referral is timely if it is received by the Contractor on or before the date started in the notice.



Articles of Agreement  
Article I

The Contractor shall take affirmative action in accordance with the provisions of this contract to insure that applicants are employed, and that employees are treated during employment without regard to race, religion, color, age, marital status, disability, sex, sexual orientation, gender identity or national origin and that the employer shall provide harassment free work environment for the realization of the potential of each employee. Such action shall include, but not be limited to, the following: employment, upgrading, demotion or transfer, recruitment or recruitment advertising, layoff or termination, rates of pay or other forms of compensation and selection for training including apprenticeship insofar as it is within the control of the Contractor. The Contractor agrees to post in conspicuous places available to employees and applicants notices to be provided by the City setting out the provisions of the nondiscrimination clauses in this contract.

Article II

The Contractor shall in all solicitations or advertisements for employees placed by or on behalf of the Contractors state that all qualified or qualifiable applicants will be employed without regard to race, religion, color, age, marital status, disability, sex, sexual orientation, gender identity or national origin.

Article III

The Contractor shall send to each labor union or representative of workers with which it has a collective bargaining agreement or other contract or understanding a notice to be provided by the City advising the labor union or worker's representative of the Contractor's equal employment opportunity and affirmative action commitments. Such notices shall be posted in conspicuous places available to employees and applicants for employment.

Article V

The Contractor agrees that it will comply with all provisions of the Affirmative Action Ordinance of the City of Madison, including the contract compliance requirements. The Contractor agrees to submit the model affirmative action plan for public works contractors in a form approved by the Affirmative Action Division Manager.

Article VI

The Contractor will maintain records as required by Section 39.02(9)(f) of the Madison General Ordinances and will provide the City Affirmative Action Division with access to such records and to persons who have relevant and necessary information, as provided in Section 39.02(9)(f). The City agrees to keep all such records confidential, except to the extent that public inspection is required by law.

Article VII

In the event of the Contractor's or subcontractor's failure to comply with the Equal Employment Opportunity and Affirmative Action Provisions of this contract or Section 39.03 and 39.02 of the Madison General Ordinances, it is agreed that the City at its option may do any or all of the following:

1. Cancel, terminate or suspend this Contract in whole or in part.
2. Declare the Contractor ineligible for further City contracts until the Affirmative Action requirements are met.

3. Recover on behalf of the City from the prime Contractor 0.5 percent of the contract award price for each week that such party fails or refuses to comply, in the nature of liquidated damages, but not to exceed a total of five percent (5%) of the contract price, or five thousand dollars (\$5,000), whichever is less. Under public works contracts, if a subcontractor is in noncompliance, the City may recover liquidated damages from the prime Contractor in the manner described above. The preceding sentence shall not be construed to prohibit a prime Contractor from recovering the amount of such damage from the non-complying subcontractor.

#### Article VIII

The Contractor shall include the above provisions of this contract in every subcontract so that such provisions will be binding upon each subcontractor. The Contractor shall take such action with respect to any subcontractor as necessary to enforce such provisions, including sanctions provided for noncompliance.

#### Article IX

The Contractor shall allow the maximum feasible opportunity to small business enterprises to compete for any subcontracts entered into pursuant to this contract. (In federally funded contracts the terms "DBE, MBE and WBE" shall be substituted for the term "small business" in this Article.)

BOOSTER PUMP STATION 115 UPGRADE  
CONTRACT NO. 7411

IN WITNESS WHEREOF, the Contractor has hereunto set his/her hand and seal and the City has caused these presents to be sealed with its corporate seal and to be subscribed by its Mayor and City Clerk the day and year first above written.

Countersigned:

MIDWEST GENERAL & MECHANICAL  
CONTRACTORS, INC.

Company Name

Debra J Kundert 3/12/15  
Witness Date  
Debra J Kundert 3/12/15  
Witness Date

[Signature] 3/12/15  
President Date  
[Signature] 3/12/15  
Secretary Date

CITY OF MADISON, WISCONSIN

Provisions have been made to pay the liability that will accrue under this contract.

Approved as to form:

[Signature]  
Finance Director

[Signature]  
City Attorney

Signed this 20th day of March, 2015

[Signature]  
Witness

[Signature] 3-20-15  
Mayor Date

[Signature]  
Witness

[Signature] 3-16-2015  
City Clerk Date



SECTION 1: PAYMENT AND PERFORMANCE BOND

KNOW ALL MEN BY THESE PRESENTS, that we MIDWEST GENERAL & MECHANICAL CONTRACTORS, INC., as principal, and

Granite Re, Inc.

Company of Oklahoma as surety, are held and firmly bound unto the City of Madison, Wisconsin, in the sum of NINE HUNDRED TWENTY-TWO THOUSAND FIVE HUNDRED EIGHTY-TWO (\$922,582.00) Dollars, lawful money of the United States, for the payment of which sum to the City of Madison, we hereby bind ourselves and our respective executors and administrators firmly by these presents.

The condition of this Bond is such that if the above bounden shall on his/her part fully and faithfully perform all of the terms of the Contract entered into between him/herself and the City of Madison for the construction of:

**BOOSTER PUMP STATION 115 UPGRADE  
CONTRACT NO. 7411**

In Madison, Wisconsin, and shall pay all claims for labor performed and material furnished in the prosecution of said work, and save the City harmless from all claims for damages because of negligence in the prosecution of said work, and shall save harmless the said City from all claims for compensation (under Chapter 102, Wisconsin Statutes) of employees and employees of subcontractor, then this Bond is to be void, otherwise of full force, virtue and effect.

Signed and sealed this 3rd day of March, 2015

Countersigned:

[Signature]  
Witness  
[Signature]  
Secretary

**MIDWEST GENERAL & MECHANICAL  
CONTRACTORS, INC.**  
Company Name (Principal)  
[Signature]  
President Seal

Approved as to form:

[Signature]  
City Attorney

Granite Re, Inc.  
Surety Seal  
 Salary Employee     Commission  
By [Signature]  
Attorney-in-Fact Robert Downey

This certifies that I have been duly licensed as an agent for the above company in Wisconsin under License No. 2587534 for the year 2015, and appointed as attorney-in-fact with authority to execute this payment and performance bond which power of attorney has not been revoked.

March 3, 2015  
Date

[Signature]  
Agent Signature Robert Downey



**GRANITE RE, INC.**  
**GENERAL POWER OF ATTORNEY**

**Know all Men by these Presents:**

That GRANITE RE, INC., a corporation organized and existing under the laws of the State of OKLAHOMA and having its principal office at the City of OKLAHOMA CITY in the State of OKLAHOMA does hereby constitute and appoint:

MICHAEL J. DOUGLAS; CHRIS STEINAGEL; CHRISTOPHER M. KEMP; KARLA HEFFRON; ROBERT DOWNEY; CONNIE SMITH its true and lawful Attorney-in-Fact(s) for the following purposes, to wit:

To sign its name as surety to, and to execute, seal and acknowledge any and all bonds, and to respectively do and perform any and all acts and things set forth in the resolution of the Board of Directors of the said GRANITE RE, INC. a certified copy of which is hereto annexed and made a part of this Power of Attorney; and the said GRANITE RE, INC. through us, its Board of Directors, hereby ratifies and confirms all and whatsoever the said:

MICHAEL J. DOUGLAS; CHRIS STEINAGEL; CHRISTOPHER M. KEMP; KARLA HEFFRON; ROBERT DOWNEY; CONNIE SMITH may lawfully do in the premises by virtue of these presents.

**In Witness Whereof**, the said GRANITE RE, INC. has caused this instrument to be sealed with its corporate seal, duly attested by the signatures of its President and Secretary/Treasurer, this 3<sup>rd</sup> day of July, 2013.

STATE OF OKLAHOMA     )  
                                  ) SS:  
COUNTY OF OKLAHOMA )

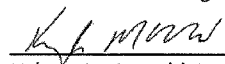

  
\_\_\_\_\_  
Kenneth D. Whittington, President  
  
\_\_\_\_\_  
Kyle P. McDonald, Treasurer

On this 3<sup>rd</sup> day of July, 2013, before me personally came Kenneth D. Whittington, President of the GRANITE RE, INC. Company and Kyle P. McDonald, Secretary/Treasurer of said Company, with both of whom I am personally acquainted, who being by me severally duly sworn, said, that they, the said Kenneth D. Whittington and Kyle P. McDonald were respectively the President and the Secretary/Treasurer of GRANITE RE, INC., the corporation described in and which executed the foregoing Power of Attorney; that they each knew the seal of said corporation; that the seal affixed to said Power of Attorney was such corporate seal, that it was so fixed by order of the Board of Directors of said corporation, and that they signed their name thereto by like order as President and Secretary/Treasurer, respectively, of the Company.

My Commission Expires:  
August 8, 2017  
Commission #: 01013257



  
\_\_\_\_\_  
Kathleen E. Carlson  
Notary Public

**GRANITE RE, INC.**  
Certificate

THE UNDERSIGNED, being the duly elected and acting Secretary/Treasurer of Granite Re, Inc., an Oklahoma Corporation, HEREBY CERTIFIES that the following resolution is a true and correct excerpt from the July 15, 1987, minutes of the meeting of the Board of Directors of Granite Re, Inc. and that said Power of Attorney has not been revoked and is now in full force and effect.

“RESOLVED, that the President, any Vice President, the Secretary, and any Assistant Vice President shall each have authority to appoint individuals as attorneys-in-fact or under other appropriate titles with authority to execute on behalf of the company fidelity and surety bonds and other documents of similar character issued by the Company in the course of its business. On any instrument making or evidencing such appointment, the signatures may be affixed by facsimile. On any instrument conferring such authority or on any bond or undertaking of the Company, the seal, or a facsimile thereof, may be impressed or affixed or in any other manner reproduced; provided, however, that the seal shall not be necessary to the validity of any such instrument or undertaking.”

IN WITNESS WHEREOF, the undersigned has subscribed this Certificate and affixed the corporate seal of the Corporation this 3<sup>rd</sup> day of March, 2013.

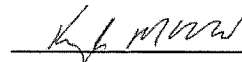

  
\_\_\_\_\_  
Kyle P. McDonald, Secretary/Treasurer





**SECTION J: PREVAILING WAGE RATES**



**PREVAILING WAGE RATE DETERMINATION**

Issued by the State of Wisconsin  
Department of Workforce Development  
Pursuant to s. 66.0903, Wis. Stats.  
Issued On: 01/06/2014  
Amended On: 02/28/2014

**DETERMINATION NUMBER:** 201400001

**EXPIRATION DATE:** Prime Contracts MUST Be Awarded or Negotiated On Or Before 12/31/2014. If NOT, You MUST Reapply.

**PROJECT NAME:** ALL PUBLIC WORKS PROJECTS UNDER SEC 66.0903, STATS - CITY OF MADISON

**PROJECT LOCATION:** MADISON CITY, DANE COUNTY, WI

**CONTRACTING AGENCY:** CITY OF MADISON-ENGINEERING

<b>CLASSIFICATION:</b>	Contractors are responsible for correctly classifying their workers. Either call the Department of Workforce Development (DWD) with trade or classification questions or consult DWD's Dictionary of Occupational Classifications & Work Descriptions on the DWD website at: <a href="http://dwd.wisconsin.gov/er/prevailing_wage_rate/Dictionary/dictionary_main.htm">dwd.wisconsin.gov/er/prevailing_wage_rate/Dictionary/dictionary_main.htm</a> .
<b>OVERTIME:</b>	Time and one-half must be paid for all hours worked: <ul style="list-style-type: none"><li>- over 10 hours per day on prevailing wage projects</li><li>- over 40 hours per calendar week</li><li>- Saturday and Sunday</li><li>- on all of the following holidays: January 1; the last Monday in May; July 4; the 1st Monday in September; the 4th Thursday in November; December 25;</li><li>- The day before if January 1, July 4 or December 25 falls on a Saturday;</li><li>- The day following if January 1, July 4 or December 25 falls on a Sunday.</li></ul> Apply the time and one-half overtime calculation to whichever is higher between the Hourly Basic Rate listed on this project determination or the employee's regular hourly rate of pay. Add any applicable Premium or DOT Premium to the Hourly Basic Rate before calculating overtime.  A DOT Premium (discussed below) may supersede this time and one-half requirement.
<b>FUTURE INCREASE:</b>	When a specific trade or occupation requires a future increase, you MUST add the full hourly increase to the "TOTAL" on the effective date(s) indicated for the specific trade or occupation.
<b>PREMIUM PAY:</b>	If indicated for a specific trade or occupation, the full amount of such pay MUST be added to the "HOURLY BASIC RATE OF PAY" indicated for such trade or occupation, whenever such pay is applicable.
<b>DOT PREMIUM:</b>	This premium only applies to highway and bridge projects owned by the Wisconsin Department of Transportation and to the project type heading "Airport Pavement or State Highway Construction." DO NOT apply the premium calculation under any other project type on this determination.
<b>APPRENTICES:</b>	Pay apprentices a percentage of the applicable journey person's hourly basic rate of pay and hourly fringe benefit contributions specified in this determination. Obtain the appropriate percentage from each apprentice's contract or indenture.
<b>SUBJOURNEY:</b>	Subjourney wage rates may be available for some of the trades or occupations indicated below with the exception of laborers, truck drivers and heavy equipment operators. Any employer interested in using a subjourney classification on this project MUST complete Form ERD-10880 and request the applicable wage rate from the Department of Workforce Development PRIOR to using the subjourney worker on this project.

This document **MUST BE POSTED** by the **CONTRACTING AGENCY** in at least one conspicuous and easily accessible place **at the site of the project**. A local governmental unit may post this document at the place normally used to post public notices if there is no common site on the project. This document **MUST** remain posted during the entire time any worker is employed on the project and **MUST** be physically incorporated into the specifications and all contracts and subcontracts. If you have any questions, please write to the Equal Rights Division, Labor Standards Bureau, P.O. Box 8928, Madison, Wisconsin 53708 or call (608) 266-6861.

**The following statutory provisions apply to local governmental unit projects of public works and are set forth below pursuant to the requirements of s. 66.0903(8), Stats.**

**s. 66.0903 (1) (f) & s. 103.49 (1) (c) "PREVAILING HOURS OF LABOR"** for any trade or occupation in any area means 10 hours per day and 40 hours per week and may not include any hours worked on a Saturday or Sunday or on any of the following holidays:

1. January 1.
2. The last Monday in May.
3. July 4.
4. The first Monday in September.
5. The 4th Thursday in November.
6. December 25.
7. The day before if January 1, July 4 or December 25 falls on a Saturday.
8. The day following if January 1, July 4 or December 25 falls on a Sunday.

**s. 66.0903 (10) RECORDS; INSPECTION; ENFORCEMENT.**

(a) Each contractor, subcontractor, or contractor's or subcontractor's agent performing work on a project of public works that is subject to this section shall keep full and accurate records clearly indicating the name and trade or occupation of every person performing the work described in sub. (4) and an accurate record of the number of hours worked by each of those persons and the actual wages paid for the hours worked.

**s. 66.0903 (11) LIABILITY AND PENALTIES.**

(a) 1. Any contractor, subcontractor, or contractor's or subcontractor's agent who fails to pay the prevailing wage rate determined by the department under sub. (3) or who pays less than 1.5 times the hourly basic rate of pay for all hours worked in excess of the prevailing hours of labor is liable to any affected employee in the amount of his or her unpaid wages or his or her unpaid overtime compensation and in an additional amount as liquidated damages as provided under subd. 2., 3., whichever is applicable.

2. If the department determines upon inspection under sub. (10) (b) or (c) that a contractor, subcontractor, or contractor's or subcontractor's agent has failed to pay the prevailing wage rate determined by the department under sub. (3) or has paid less than 1.5 times the hourly basic rate of pay for all hours worked in excess of the prevailing hours of labor, the department shall order the contractor to pay to any affected employee the amount of his or her unpaid wages or his or her unpaid overtime compensation and an additional amount equal to 100 percent of the amount of those unpaid wages or that unpaid overtime compensation as liquidated damages within a period specified by the department in the order.

3. In addition to or in lieu of recovering the liability specified in subd. 1. as provided in subd. 2., any employee for and in behalf of that employee and other employees similarly situated may commence an action to recover that liability in any court of competent jurisdiction. If the court finds that a contractor, subcontractor, or contractor's or subcontractor's agent has failed to pay the prevailing wage rate determined by the department under sub. (3) or has paid less than 1.5 times the hourly basic rate of pay for all hours worked in excess of the prevailing hours of labor, the court shall order the contractor, subcontractor, or agent to pay to any affected employee the amount of his or her unpaid wages or his or her unpaid overtime compensation and an additional amount equal to 100 percent of the amount of those unpaid wages or that unpaid overtime compensation as liquidated damages.

5. No employee may be a party plaintiff to an action under subd. 3. unless the employee consents in writing to become a party and the consent is filed in the court in which the action is brought. Notwithstanding s. 814.04 (1), the court shall, in addition to any judgment awarded to the plaintiff, allow reasonable attorney fees and costs to be paid by the defendant.

**BUILDING OR HEAVY CONSTRUCTION**

includes sheltered enclosures with walk-in access for the purpose of housing persons, employees, machinery, equipment or supplies and non-sheltered work such as canals, dams, dikes, reservoirs, storage tanks, etc. A sheltered enclosure need not be "habitable" in order to be considered a building. The installation of machinery and/or equipment, both above and below grade level, does not change a project's character as a building. On-site grading, utility work and landscaping are included within this definition. Residential buildings of four (4) stories or less, agricultural buildings, parking lots and driveways are NOT included within this definition.

**SKILLED TRADES**Fringe Benefits Must Be Paid On All Hours Worked

<u>CODE</u>	<u>TRADE OR OCCUPATION</u>	<u>HOURLY BASIC RATE OF PAY</u> \$	<u>HOURLY FRINGE BENEFITS</u> \$	<u>TOTAL</u> \$
101	Acoustic Ceiling Tile Installer	30.48	15.90	46.38
102	Boilermaker Future Increase(s): Add \$1.50/hr on 1/01/2015; Add \$1.50/hr. on 01/01/2016	32.05	28.04	60.09
103	Bricklayer, Blocklayer or Stonemason Premium Increase(s): DOT PREMIUM: Pay two times the hourly basic rate on Sunday, New Year's Day, Memorial Day, Independence Day, Labor Day, Thanksgiving Day & Christmas Day.	32.01	17.35	49.36
104	Cabinet Installer	30.48	15.90	46.38
105	Carpenter	30.48	15.90	46.38
106	Carpet Layer or Soft Floor Coverer	30.48	15.90	46.38
107	Cement Finisher	31.58	16.13	47.71
108	Drywall Taper or Finisher	24.80	16.60	41.40
109	Electrician Premium Increase(s): DOT PREMIUM: Pay two times the hourly basic rate on Sunday, New Year's Day, Memorial Day, Independence Day, Labor Day, Thanksgiving Day & Christmas Day.	34.07	19.25	53.32
110	Elevator Constructor	42.86	23.84	66.70
111	Fence Erector	24.72	0.00	24.72
112	Fire Sprinkler Fitter	36.07	18.73	54.80
113	Glazier	38.03	13.42	51.45
114	Heat or Frost Insulator	33.68	24.31	57.99
115	Insulator (Batt or Blown)	15.00	9.50	24.50
116	Ironworker	31.25	19.46	50.71
117	Lather	30.48	15.90	46.38

<b>Fringe Benefits Must Be Paid On <u>All</u> Hours Worked</b>		<b>HOURLY BASIC RATE OF PAY</b>	<b>HOURLY FRINGE BENEFITS</b>	<b>TOTAL</b>
<b>CODE</b>	<b>TRADE OR OCCUPATION</b>	<b>\$</b>	<b>\$</b>	<b>\$</b>
118	Line Constructor (Electrical)	38.25	17.31	55.56
119	Marble Finisher	26.89	19.18	46.07
120	Marble Mason	32.01	17.35	49.36
121	Metal Building Erector	22.00	10.00	32.00
122	Millwright	32.11	15.95	48.06
123	Overhead Door Installer	20.95	4.94	25.89
124	Painter	24.50	16.60	41.10
125	Pavement Marking Operator	30.00	0.00	30.00
126	Piledriver	30.98	15.90	46.88
127	Pipeline Fuser or Welder (Gas or Utility)	30.79	19.74	50.53
129	Plasterer	31.03	17.71	48.74
130	Plumber Future Increase(s): Add \$1/hr on 6/1/2014.	36.42	16.87	53.29
132	Refrigeration Mechanic	41.60	16.71	58.31
133	Roofer or Waterproofor	29.40	6.25	35.65
134	Sheet Metal Worker	34.45	22.57	57.02
135	Steamfitter Future Increase(s): Add \$1.70/hr on 6/1/2014.	42.95	17.81	60.76
137	Teledata Technician or Installer Premium Increase(s): DOT PREMIUM: Pay two times the hourly basic rate on Sunday, New Year's Day, Memorial Day, Independence Day, Labor Day, Thanksgiving Day & Christmas Day.	22.25	12.24	34.49
138	Temperature Control Installer	32.94	18.80	51.74
139	Terrazzo Finisher	26.89	19.18	46.07
140	Terrazzo Mechanic	30.20	18.42	48.62
141	Tile Finisher	23.85	17.18	41.03
142	Tile Setter	29.81	17.18	46.99
143	Tuckpointer, Caulker or Cleaner	35.25	13.15	48.40
144	Underwater Diver (Except on Great Lakes)	34.48	15.90	50.38
146	Well Driller or Pump Installer	25.32	15.65	40.97
147	Siding Installer	25.92	18.04	43.96

<b>Fringe Benefits Must Be Paid On <u>All</u> Hours Worked</b>		<b>HOURLY BASIC RATE OF PAY</b>	<b>HOURLY FRINGE BENEFITS</b>	<b>TOTAL</b>
<b>CODE</b>	<b>TRADE OR OCCUPATION</b>	<b>\$</b>	<b>\$</b>	<b>\$</b>
150	Heavy Equipment Operator - ELECTRICAL LINE CONSTRUCTION ONLY	29.16	14.34	43.50
151	Light Equipment Operator -ELECTRICAL LINE CONSTRUCTION ONLY	30.60	14.86	45.46
152	Heavy Truck Driver - ELECTRICAL LINE CONSTRUCTION ONLY	26.78	13.63	40.41
153	Light Truck Driver - ELECTRICAL LINE CONSTRUCTION ONLY	24.86	12.97	37.83
154	Groundman - ELECTRICAL LINE CONSTRUCTION ONLY	21.75	12.70	34.45

**TRUCK DRIVERS**

<b>Fringe Benefits Must Be Paid On <u>All</u> Hours Worked</b>		<b>HOURLY BASIC RATE OF PAY</b>	<b>HOURLY FRINGE BENEFITS</b>	<b>TOTAL</b>
<b>CODE</b>	<b>TRADE OR OCCUPATION</b>	<b>\$</b>	<b>\$</b>	<b>\$</b>
201	Single Axle or Two Axle	32.39	18.46	50.85
203	Three or More Axle	18.00	22.88	40.88
204	Articulated, Euclid, Dumptor, Off Road Material Hauler	32.89	18.96	51.85
205	Pavement Marking Vehicle	18.00	22.88	40.88
207	Truck Mechanic	18.00	22.88	40.88

**LABORERS**

<b>Fringe Benefits Must Be Paid On <u>All</u> Hours Worked</b>		<b>HOURLY BASIC RATE OF PAY</b>	<b>HOURLY FRINGE BENEFITS</b>	<b>TOTAL</b>
<b>CODE</b>	<b>TRADE OR OCCUPATION</b>	<b>\$</b>	<b>\$</b>	<b>\$</b>
301	General Laborer Premium Increase(s): Add \$1.00/hr for certified welder; Add \$.25/hr for mason tender	24.21	14.63	38.84
302	Asbestos Abatement Worker	24.36	14.44	38.80
303	Landscaper	21.01	9.37	30.38
310	Gas or Utility Pipeline Laborer (Other Than Sewer and Water)	21.01	13.63	34.64
311	Fiber Optic Laborer (Outside, Other Than Concrete Encased) Premium Increase(s): DOT PREMIUMS: Pay two times the hourly basic rate on New Year's Day, Memorial Day, Independence Day, Labor Day, Thanksgiving Day & Christmas Day.	18.33	13.65	31.98
314	Railroad Track Laborer	23.46	3.30	26.76
315	Final Construction Clean-Up Worker	16.00	0.00	16.00

**HEAVY EQUIPMENT OPERATORS  
SITE PREPARATION, UTILITY OR LANDSCAPING WORK ONLY**

Fringe Benefits Must Be Paid On <u>All</u> Hours Worked		HOURLY BASIC RATE OF PAY	HOURLY FRINGE BENEFITS	TOTAL
CODE	TRADE OR OCCUPATION	\$	\$	\$
501	Air Track, Rotary or Percussion Drilling Machine &/or Hammers, Blaster; Asphalt Milling Machine; Boring Machine (Directional, Horizontal or Vertical); Backhoe (Track Type) Having a Mfg's Rated Capacity of 130,000 Lbs. or Over; Backhoe (Track Type) Having a Mfg's Rated Capacity of Under 130,000 Lbs., Backhoe (Mini, 15,000 Lbs. & Under); Bulldozer or Endloader (Over 40 hp); Compactor (Self-Propelled 85 Ft Total Drum Width & Over, or Tractor Mounted, Towed & Light Equipment); Concrete Batch Plant, Batch Hopper; Concrete Breaker (Large, Auto, Vibratory/Sonic, Manual or Remote); Crane, Shovel, Dragline, Clamshells; Forklift (Machinery Moving or Steel Erection, 25 Ft & Over); Gradall (Cruz-Aire Type); Grader or Motor Patrol; Master Mechanic; Mechanic or Welder; Robotic Tool Carrier (With or Without Attachments); Scraper (Self Propelled or Tractor Drawn) 5 cu yds or More Capacity; Tractor or Truck Mounted Hydraulic Backhoe; Tractor or Truck Mounted Hydraulic Crane (10 Tons or Under); Tractor (Scraper, Dozer, Pusher, Loader); Trencher (Wheel Type or Chain Type Having Over 8 Inch Bucket).	33.42	18.96	52.38
502	Backfiller; Broom or Sweeper; Bulldozer or Endloader (Under 40 hp); Environmental Burner; Forestry Equipment, Timbco, Tree Shear, Tub Grinder, Processor; Jeep Digger; Screed (Milling Machine); Skid Rig; Straddle Carrier or Travel Lift; Stump Chipper; Trencher (Wheel Type or Chain Type Having 8 Inch Bucket & Under).	32.89	18.96	51.85
503	Air Compressor (&/or 400 CFM or Over); Augers (Vertical & Horizontal); Compactor (Self-Propelled 84 Ft Total Drum Width & Under, or Tractor Mounted, Towed & Light Equipment); Crusher, Screening or Wash Plant; Farm or Industrial Type Tractor; Forklift; Generator (&/or 150 KW or Over); Greaser; High Pressure Utility Locating Machine (Daylighting Machine); Mulcher; Oiler; Post Hole Digger or Driver; Pump (3 Inch or Over) or Well Points; Refrigeration Plant or Freeze Machine; Rock, Stone Breaker; Skid Steer Loader (With or Without Attachments); Vibratory Hammer or Extractor, Power Pack.	30.82	18.96	49.78
504	Work Performed on the Great Lakes Including Diver; Wet Tender or Hydraulic Dredge Engineer.	38.80	20.17	58.97
505	Work Performed on the Great Lakes Including Crane or Backhoe Operator; Assistant Hydraulic Dredge Engineer; Hydraulic Dredge Leverman or Diver's Tender; Mechanic or Welder; 70 Ton & Over Tug Operator. Premium Increase(s): Add \$.50/hr for Friction Crane, Lattice Boom or Crane Certification (CCO).	41.65	21.71	63.36
506	Work Performed on the Great Lakes Including Deck Equipment Operator or Machineryman (Maintains Cranes Over 50 Tons or Backhoes 115,000 Lbs. or More); Tug, Launch or Loader, Dozer or Like Equipment When Operated on a Barge, Breakwater Wall, Slip, Dock or Scow, Deck Machinery.	37.10	21.57	58.67



507	Work Performed on the Great Lakes Including Deck Equipment Operator, Machineryman or Fireman (Operates 4 Units or More or Maintains Cranes 50 Tons or Under or Backhoes 115,000 Lbs. or Under); Deck Hand, Deck Engineer or Assistant Tug Operator; Off Road Trucks - Great Lakes ONLY.	34.50	20.04	54.54
-----	---	-------	-------	-------

**HEAVY EQUIPMENT OPERATORS  
EXCLUDING SITE PREPARATION, UTILITY, PAVING LANDSCAPING WORK**

Fringe Benefits Must Be Paid On All Hours Worked

<u>CODE</u>	<u>TRADE OR OCCUPATION</u>	<u>HOURLY BASIC RATE OF PAY</u> \$	<u>HOURLY FRINGE BENEFITS</u> \$	<u>TOTAL</u> \$
508	Boring Machine (Directional); Crane, Tower Crane, Pedestal Tower or Derrick, With or Without Attachments, With a Lifting Capacity of Over 100 Tons, Self-Erecting Tower Crane With a Lifting Capacity of Over 4,000 Lbs., Crane With Boom Dollies; Crane, Tower Crane, Pedestal Tower or Derrick, With Boom, Leads &/or Jib Lengths Measuring 176 Ft or Over; Master Mechanic. Premium Increase(s): Add \$.50/hr for >200 Ton / Add \$1/hr at 300 Ton / Add \$1.50/hr at 400 Ton / Add \$2/hr at 500 Ton & Over.	35.62	18.96	54.58
509	Backhoe (Track Type) Having a Mfg's Rated Capacity of 130,000 Lbs. or Over; Boring Machine (Horizontal or Vertical); Caisson Rig; Crane, Tower Crane, Portable Tower, Pedestal Tower or Derrick, With or Without Attachments, With a Lifting Capacity of 100 Tons or Under, Self-Erecting Tower Crane With A Lifting Capacity Of 4,000 Lbs. & Under; Crane, Tower Crane, Portable Tower, Pedestal Tower or Derrick, With Boom, Leads &/or Jib Lengths Measuring 175 Ft or Under; Pile Driver; Versi Lifts, Tri-Lifts & Gantrys (20,000 Lbs. & Over).	36.35	6.95	43.30
510	Backhoe (Track Type) Having a Mfg.'s Rated Capacity of Under 130,000 Lbs., Backhoe (Mini, 15,000 Lbs. & Under); Concrete Bump Cutter, Grinder, Planing or Grooving Machine; Concrete Laser/Screed; Concrete Paver (Slipform); Concrete Pump (Over 46 Meter), Concrete Conveyor (Rotec or Bidwell Type); Concrete Slipform Placer Curb & Gutter Machine; Concrete Spreader & Distributor; Dredge (NOT Performing Work on the Great Lakes); Forklift (Machinery Moving or Steel Erection, 25 Ft & Over); Gradall (Cruz-Aire Type); Hydro-Blaster (10,000 PSI or Over); Milling Machine; Skid Rig; Traveling Crane (Bridge Type).	33.42	18.96	52.38
511	Air, Track, Rotary or Percussion Drilling Machine &/or Hammers, Blaster; Bulldozer or Endloader (Over 40 hp); Compactor (Self-Propelled 85 Ft Total Drum Width & Over, or Tractor Mounted, Towed & Light Equipment); Concrete Pump (46 Meter & Under), Concrete Conveyor (Rotec or Bidwell Type); Crane (Carry Deck, Mini) or Truck Mounted Hydraulic Crane (10 Tons or Under); Environmental Burner; Gantrys (Under 20,000 Lbs.); Grader or Motor Patrol; High Pressure Utility Locating Machine (Daylighting Machine); Manhoist; Material or Stack Hoist; Mechanic or Welder; Railroad Track Rail Leveling Machine, Tie Placer, Extractor, Tamper, Stone Leveler or Rehabilitation Equipment; Roller (Over 5 Ton); Scraper (Self Propelled or Tractor Drawn) 5 cu yd or More Capacity; Screed (Milling Machine); Sideboom; Straddle Carrier or Travel Lift; Tining or Curing Machine; Tractor (Scraper, Dozer, Pusher, Loader); Tractor or Truck Mounted Hydraulic Backhoe; Tractor or Truck Mounted Hydraulic Crane (10 Tons or Under); Trencher (Wheel Type or Chain Type Having Over 8-Inch Bucket).	32.89	18.96	51.85

<b>Fringe Benefits Must Be Paid On <u>All</u> Hours Worked</b>		<b>HOURLY BASIC RATE OF PAY</b>	<b>HOURLY FRINGE BENEFITS</b>	<b>TOTAL</b>
<b>CODE</b>	<b>TRADE OR OCCUPATION</b>	<b>\$</b>	<b>\$</b>	<b>\$</b>
512	Backfiller; Broom or Sweeper; Bulldozer or Endloader (Under 40 hp); Compactor (Self-Propelled 84 Ft Total Drum Width & Under, or Tractor Mounted, Towed & Light Equipment); Concrete Batch Plant, Batch Hopper; Concrete Breaker (Large, Auto, Vibratory/Sonic, Manual or Remote); Concrete Conveyor System; Concrete Finishing Machine (Road Type); Fireman (Pile Driver & Derrick NOT Performing Work on the Great Lakes); Grout Pump; Hoist (Tugger, Automatic); Industrial Locomotives; Jeep Digger; Lift Slab Machine; Mulcher; Roller (Rubber Tire, 5 Ton or Under); Screw or Gypsum Pumps; Stabilizing or Concrete Mixer (Self-Propelled or 14S or Over); Stump Chipper; Trencher (Wheel Type or Chain Type Having 8-Inch Bucket & Under); Winches & A-Frames.	30.82	18.96	49.78
513	Air Compressor (&/or 400 CFM or Over); Air, Electric or Hydraulic Jacking System; Augers (Vertical & Horizontal); Boatmen (NOT Performing Work on the Great Lakes); Boiler (Temporary Heat); Crusher, Screening or Wash Plant; Elevator; Farm or Industrial Type Tractor; Fireman (Asphalt Plant NOT Performing Work on the Great Lakes); Forklift; Generator (&/or 150 KW or Over); Greaser; Heaters (Mechanical); Loading Machine (Conveyor); Oiler; Post Hole Digger or Driver; Prestress Machine; Pump (3 Inch or Over) or Well Points; Refrigeration Plant or Freeze Machine; Robotic Tool Carrier (With or Without Attachments); Rock, Stone Breaker; Skid Steer Loader (With or Without Attachments); Vibratory Hammer or Extractor, Power Pack.	24.19	17.89	42.08
514	Gas or Utility Pipeline, Except Sewer & Water (Primary Equipment).	36.34	21.14	57.48
515	Gas or Utility Pipeline, Except Sewer & Water (Secondary Equipment). Future Increase(s): Add \$1.60/hr on 06/01/2014; Add \$1.65/hr on 06/01/2015.	32.32	18.55	50.87
516	Fiber Optic Cable Equipment Future Increase(s): Add \$1.75/hr on 02/01/2014.	27.89	17.20	45.09

**SEWER, WATER OR TUNNEL CONSTRUCTION**

includes those projects that primarily involve public sewer or water distribution, transmission or collection systems and related tunnel work (excluding buildings).

**SKILLED TRADES**

<b>Fringe Benefits Must Be Paid On <u>All</u> Hours Worked</b>		<b>HOURLY BASIC RATE OF PAY</b>	<b>HOURLY FRINGE BENEFITS</b>	<b>TOTAL</b>
<b>CODE</b>	<b>TRADE OR OCCUPATION</b>	<b>\$</b>	<b>\$</b>	<b>\$</b>
103	Bricklayer, Blocklayer or Stonemason Premium Increase(s): DOT PREMIUM: Pay two times the hourly basic rate on Sunday, New Year's Day, Memorial Day, Independence Day, Labor Day, Thanksgiving Day & Christmas Day.	35.10	18.40	53.50
105	Carpenter Future Increase(s): Add \$1.25/hr on 6/2/2014. Premium Increase(s): DOT PREMIUM: Pay two times the hourly basic rate on Sunday, New Year's Day, Memorial Day, Independence Day, Labor Day, Thanksgiving Day & Christmas Day.	33.68	19.81	53.49
107	Cement Finisher Future Increase(s): Add \$1.87 on 6/1/14; Add \$1.87 on 6/1/15; Add \$1.75 on 6/1/16. Premium Increase(s): DOT PREMIUMS: 1) Pay two times the hourly basic rate on Sunday, New Year's Day, Memorial Day, Independence Day, Labor Day, Thanksgiving Day & Christmas Day. 2) Add \$1.40/hr when the Wisconsin Department of Transportation or responsible governing agency requires that work be performed at night under artificial illumination with traffic control and the work is completed after sunset and before sunrise.	33.51	16.13	49.64
109	Electrician Premium Increase(s): DOT PREMIUM: Pay two times the hourly basic rate on Sunday, New Year's Day, Memorial Day, Independence Day, Labor Day, Thanksgiving Day & Christmas Day.	32.82	22.61	55.43
111	Fence Erector	24.72	0.00	24.72
116	Ironworker	31.25	19.46	50.71
118	Line Constructor (Electrical)	38.25	17.31	55.56
125	Pavement Marking Operator	16.00	7.35	23.35
126	Piledriver	30.98	15.90	46.88
130	Plumber	33.75	14.07	47.82
135	Steamfitter	42.45	16.71	59.16
137	Teledata Technician or Installer	21.89	11.85	33.74

<b>Fringe Benefits Must Be Paid On <u>All</u> Hours Worked</b>		<b>HOURLY BASIC RATE OF PAY</b>	<b>HOURLY FRINGE BENEFITS</b>	<b>TOTAL</b>
<b>CODE</b>	<b>TRADE OR OCCUPATION</b>	<b>\$</b>	<b>\$</b>	<b>\$</b>
143	Tuckpointer, Caulker or Cleaner	35.25	13.15	48.40
144	Underwater Diver (Except on Great Lakes)	38.80	20.17	58.97
146	Well Driller or Pump Installer	25.32	15.65	40.97
150	Heavy Equipment Operator - ELECTRICAL LINE CONSTRUCTION ONLY	29.16	14.34	43.50
151	Light Equipment Operator -ELECTRICAL LINE CONSTRUCTION ONLY	30.60	14.86	45.46
152	Heavy Truck Driver - ELECTRICAL LINE CONSTRUCTION ONLY	26.78	13.63	40.41
153	Light Truck Driver - ELECTRICAL LINE CONSTRUCTION ONLY	24.86	12.97	37.83
154	Groundman - ELECTRICAL LINE CONSTRUCTION ONLY	21.75	12.70	34.45

**TRUCK DRIVERS**

<b>Fringe Benefits Must Be Paid On <u>All</u> Hours Worked</b>		<b>HOURLY BASIC RATE OF PAY</b>	<b>HOURLY FRINGE BENEFITS</b>	<b>TOTAL</b>
<b>CODE</b>	<b>TRADE OR OCCUPATION</b>	<b>\$</b>	<b>\$</b>	<b>\$</b>
201	Single Axle or Two Axle	30.00	15.00	45.00
203	Three or More Axle	16.00	7.35	23.35
204	Articulated, Euclid, Dumptor, Off Road Material Hauler	32.89	18.96	51.85
205	Pavement Marking Vehicle	16.00	7.35	23.35
207	Truck Mechanic	16.00	7.35	23.35

**LABORERS**

<b>Fringe Benefits Must Be Paid On <u>All</u> Hours Worked</b>		<b>HOURLY BASIC RATE OF PAY</b>	<b>HOURLY FRINGE BENEFITS</b>	<b>TOTAL</b>
<b>CODE</b>	<b>TRADE OR OCCUPATION</b>	<b>\$</b>	<b>\$</b>	<b>\$</b>
301	General Laborer Premium Increase(s): Add \$.20 for blaster, bracer, manhole builder, caulker, bottomman and power tool; Add \$.55 for pipelayer; Add \$1.00 for tunnel work 0-15 lbs. compressed air; Add \$2.00 for over 15-30 lbs. compressed air; Add \$3.00 for over 30 lbs. compressed air.	25.60	14.62	40.22
303	Landscaper	25.28	11.46	36.74
304	Flagperson or Traffic Control Person	24.70	10.72	35.42
311	Fiber Optic Laborer (Outside, Other Than Concrete Encased)	18.31	12.67	30.98
314	Railroad Track Laborer	23.46	3.30	26.76

**HEAVY EQUIPMENT OPERATORS  
SEWER, WATER OR TUNNEL WORK**

Fringe Benefits Must Be Paid On All Hours Worked

<u>CODE</u>	<u>TRADE OR OCCUPATION</u>	<u>HOURLY BASIC RATE OF PAY</u> \$	<u>HOURLY FRINGE BENEFITS</u> \$	<u>TOTAL</u> \$
521	Backhoe (Track Type) Having a Mfr.'s Rated Capacity of 130,000 Lbs. or Over; Caisson Rig; Crane, Tower Crane, Pedestal Tower or Derrick, With Boom, Leads &/or Jib Lengths Measuring 176 Ft or Over; Crane, Tower Crane, Pedestal Tower or Derrick, With or Without Attachments, With a Lifting Capacity of Over 100 Tons, Self-Erecting Tower Crane With a Lifting Capacity Of Over 4,000 Lbs., Crane With Boom Dollies; Master Mechanic; Pile Driver. Premium Increase(s): Add \$.25/hr for all >45 Ton lifting capacity cranes	34.62	18.96	53.58
522	Backhoe (Track Type) Having a Mfr.'s Rated Capacity of Under 130,000 Lbs., Backhoe (Mini, 15,000 Lbs. & Under); Boring Machine (Directional); Concrete Bump Cutter, Grinder, Planing or Grooving Machine; Concrete Laser/Screed; Concrete Paver (Slipform); Concrete Pump (Over 46 Meter), Concrete Conveyor (Rotec or Bidwell Type); Concrete Spreader & Distributor; Crane, Tower Crane, Portable Tower, Pedestal Tower or Derrick, With Boom, Leads &/or Jib Lengths Measuring 175 Ft or Under; Crane, Tower Crane, Portable Tower, Pedestal Tower or Derrick, With or Without Attachments, With a Lifting Capacity of 100 Tons or Under, Self-Erecting Tower Crane With a Lifting Capacity of 4,000 Lbs. & Under; Dredge (NOT Performing Work on the Great Lakes); Milling Machine; Skid Rig; Telehandler; Traveling Crane (Bridge Type).	33.42	18.96	52.38
523	Air Track, Rotary or Percussion Drilling Machine &/or Hammers, Blaster; Boring Machine (Horizontal or Vertical); Bulldozer or Endloader (Over 40 hp); Crane (Carry Deck, Mini) or Truck Mounted Hydraulic Crane (10 Tons or Under); Concrete Pump (46 Meter & Under), Concrete Conveyor (Rotec or Bidwell Type); Concrete Slipform Placer Curb & Gutter Machine; Gradall (Cruz-Aire Type); Grader or Motor Patrol; Hydro-Blaster (10,000 PSI or Over); Manhoist; Material or Stack Hoist; Mechanic or Welder; Roller (Over 5 Ton); Scraper (Self Propelled or Tractor Drawn) 5 cu yd or More Capacity; Screed (Milling Machine); Sideboom; Straddle Carrier or Travel Lift; Tractor (Scraper, Dozer, Pusher, Loader); Tractor or Truck Mounted Hydraulic Backhoe; Tractor or Truck Mounted Hydraulic Crane (10 Tons or Under); Trencher (Wheel Type or Chain Type Having Over 8-Inch Bucket).	32.89	18.96	51.85

<b>Fringe Benefits Must Be Paid On <u>All</u> Hours Worked</b>		<b>HOURLY BASIC RATE OF PAY</b>	<b>HOURLY FRINGE BENEFITS</b>	<b>TOTAL</b>
<b>CODE</b>	<b>TRADE OR OCCUPATION</b>	<b>\$</b>	<b>\$</b>	<b>\$</b>
524	Backfiller; Broom or Sweeper; Bulldozer or Endloader (Under 40 hp); Compactor (Self-Propelled 85 Ft Total Drum Width & Over, or Tractor Mounted, Towed & Light Equipment); Concrete Batch Plant, Batch Hopper; Concrete Breaker (Large, Auto, Vibratory/Sonic, Manual or Remote); Concrete Conveyor System; Concrete Finishing Machine (Road Type); Environmental Burner; Fireman (Pile Driver & Derrick NOT Performing Work on the Great Lakes); Forestry Equipment, Timbco, Tree Shear, Tub Grinder, Processor; Hoist (Tugger, Automatic); Grout Pump; Jeep Digger; Lift Slab Machine; Mulcher; Power Subgrader; Pump (3 Inch or Over) or Well Points; Robotic Tool Carrier (With or Without Attachments); Roller (Rubber Tire, 5 Ton or Under); Screw or Gypsum Pumps; Stabilizing or Concrete Mixer (Self-Propelled or 14S or Over); Stump Chipper; Tining or Curing Machine; Trencher (Wheel Type or Chain Type Having 8-Inch Bucket & Under); Winches & A-Frames. Future Increase(s): Add \$1.05/hr on 6/2/2014; Add \$1.55/hr on 6/1/2015. Premium Increase(s): Add \$.25/hr for operating tower crane.	35.11	19.45	54.56
525	Air Compressor (&/or 400 CFM or Over); Air, Electric or Hydraulic Jacking System; Augers (Vertical & Horizontal); Compactor (Self-Propelled 84 Ft Total Drum Width & Under, or Tractor Mounted, Towed & Light Equipment); Crusher, Screening or Wash Plant; Farm or Industrial Type Tractor; Fireman (Asphalt Plant NOT Performing Work on the Great Lakes); Generator (&/or 150 KW or Over); Heaters (Mechanical); High Pressure Utility Locating Machine (Daylighting Machine); Loading Machine (Conveyor); Post Hole Digger or Driver; Refrigeration Plant or Freeze Machine; Rock, Stone Breaker; Skid Steer Loader (With or Without Attachments); Vibratory Hammer or Extractor, Power Pack.	30.19	20.94	51.13
526	Boiler (Temporary Heat); Forklift; Greaser; Oiler.	24.19	17.89	42.08
527	Work Performed on the Great Lakes Including Diver; Wet Tender or Hydraulic Dredge Engineer.	38.80	20.17	58.97
528	Work Performed on the Great Lakes Including 70 Ton & Over Tug Operator; Assistant Hydraulic Dredge Engineer; Crane or Backhoe Operator; Hydraulic Dredge Leverman or Diver's Tender; Mechanic or Welder.	38.80	20.17	58.97
529	Work Performed on the Great Lakes Including Deck Equipment Operator or Machineryman (Maintains Cranes Over 50 Tons or Backhoes 115,000 Lbs. or More); Tug, Launch or Loader, Dozer or Like Equipment When Operated on a Barge, Breakwater Wall, Slip, Dock or Scow, Deck Machinery.	34.50	20.04	54.54
530	Work Performed on the Great Lakes Including Deck Equipment Operator; Machineryman or Fireman (Operates 4 Units or More or Maintains Cranes 50 Tons or Under or Backhoes 115,000 Lbs. or Under), Deck Hand, Deck Engineer or Assistant Tug Operator; Off Road Trucks - Great Lakes ONLY.	34.50	20.04	54.54

**AIRPORT PAVEMENT OR STATE HIGHWAY CONSTRUCTION**

includes all airport projects (excluding buildings) and all projects awarded by the Wisconsin Department of Transportation (excluding buildings).

**SKILLED TRADES**

Fringe Benefits Must Be Paid On <u>All</u> Hours Worked		HOURLY BASIC RATE OF PAY	HOURLY FRINGE BENEFITS	TOTAL
CODE	TRADE OR OCCUPATION	\$	\$	\$
103	Bricklayer, Blocklayer or Stonemason	32.01	17.35	49.36
105	Carpenter	30.48	15.90	46.38
107	Cement Finisher Future Increase(s): Add \$1.87 on 6/1/14; Add \$1.87 on 6/1/15; Add \$1.75 on 6/1/16. Premium Increase(s): DOT PREMIUMS: 1) Pay two times the hourly basic rate on Sunday, New Year's Day, Memorial Day, Independence Day, Labor Day, Thanksgiving Day & Christmas Day. 2) Add \$1.40/hr when the Wisconsin Department of Transportation or responsible governing agency requires that work be performed at night under artificial illumination with traffic control and the work is completed after sunset and before sunrise.	33.51	16.13	49.64
109	Electrician Premium Increase(s): DOT PREMIUM: Pay two times the hourly basic rate on Sunday, New Year's Day, Memorial Day, Independence Day, Labor Day, Thanksgiving Day & Christmas Day.	34.07	19.25	53.32
111	Fence Erector	24.72	0.00	24.72
116	Ironworker	31.25	19.46	50.71
118	Line Constructor (Electrical)	38.25	17.31	55.56
124	Painter	21.87	11.37	33.24
125	Pavement Marking Operator	30.00	0.00	30.00
126	Piledriver	30.98	15.90	46.88
133	Roofer or Waterproofer	29.40	6.25	35.65
137	Teledata Technician or Installer	21.89	11.85	33.74
143	Tuckpointer, Caulker or Cleaner	35.25	13.15	48.40
144	Underwater Diver (Except on Great Lakes)	34.48	15.90	50.38
150	Heavy Equipment Operator - ELECTRICAL LINE CONSTRUCTION ONLY	34.43	15.24	49.67
151	Light Equipment Operator -ELECTRICAL LINE CONSTRUCTION ONLY	35.50	15.89	51.39

<b>Fringe Benefits Must Be Paid On <u>All</u> Hours Worked</b>		<b>HOURLY BASIC RATE OF PAY</b>	<b>HOURLY FRINGE BENEFITS</b>	<b>TOTAL</b>
<b>CODE</b>	<b>TRADE OR OCCUPATION</b>	<b>\$</b>	<b>\$</b>	<b>\$</b>
152	Heavy Truck Driver - ELECTRICAL LINE CONSTRUCTION ONLY	26.78	13.63	40.41
153	Light Truck Driver - ELECTRICAL LINE CONSTRUCTION ONLY	24.86	12.97	37.83
154	Groundman - ELECTRICAL LINE CONSTRUCTION ONLY	21.75	12.70	34.45

**TRUCK DRIVERS**

<b>Fringe Benefits Must Be Paid On <u>All</u> Hours Worked</b>		<b>HOURLY BASIC RATE OF PAY</b>	<b>HOURLY FRINGE BENEFITS</b>	<b>TOTAL</b>
<b>CODE</b>	<b>TRADE OR OCCUPATION</b>	<b>\$</b>	<b>\$</b>	<b>\$</b>
201	Single Axle or Two Axle	34.22	19.90	54.12
203	Three or More Axle Future Increase(s): Add \$1.30/hr on 6/1/2014. Premium Increase(s): DOT PREMIUM: Pay two times the hourly basic rate on Sunday, New Year's Day, Memorial Day, Independence Day, Labor Day, Thanksgiving Day & Christmas Day.	24.52	17.77	42.29
204	Articulated, Euclid, Dumptor, Off Road Material Hauler Future Increase(s): Add \$1.75/hr on 6/1/14); Add \$1.25/hr on 6/1/15); Add \$1.30/hr on 6/1/16); Add \$1.25/hr on 6/1/17. Premium Increase(s): DOT PREMIUMS: 1) Pay two times the hourly basic rate on Sunday, New Year's Day, Memorial Day, Independence Day, Labor Day, Thanksgiving Day & Christmas Day. 2) Add \$1.50/hr night work premium. See DOT'S website for details about the applicability of this night work premium at: <a href="http://www.dot.wi.gov/business/civilrights/laborwages/pwc.htm">http://www.dot.wi.gov/business/civilrights/laborwages/pwc.htm</a> .	29.27	20.40	49.67
205	Pavement Marking Vehicle	23.31	17.13	40.44
206	Shadow or Pilot Vehicle	34.22	19.90	54.12
207	Truck Mechanic	23.31	17.13	40.44



## LABORERS

Fringe Benefits Must Be Paid On All Hours Worked

<u>CODE</u>	<u>TRADE OR OCCUPATION</u>	<u>HOURLY BASIC RATE OF PAY</u> \$	<u>HOURLY FRINGE BENEFITS</u> \$	<u>TOTAL</u> \$
301	General Laborer Future Increase(s): Add \$1.60/hr on 6/1/2014. Premium Increase(s): Add \$.10/hr for topman, air tool operator, vibrator or tamper operator (mechanical hand operated), chain saw operator and demolition burning torch laborer; Add \$.15/hr for bituminous worker (raker and luteman), formsetter (curb, sidewalk and pavement) and strike off man; Add \$.20/hr for blaster and powderman; Add \$.25/hr for bottomman; Add \$.35/hr for line and grade specialist; Add \$.45/hr for pipelayer. / DOT PREMIUMS: 1) Pay two times the hourly basic rate on Sunday, New Year's Day, Memorial Day, Independence Day, Labor Day, Thanksgiving Day & Christmas Day. 2) Add \$1.25/hr for work on projects involving temporary traffic control setup, for lane and shoulder closures, when work under artificial illumination conditions is necessary as required by the project provisions (including prep time prior to and/or cleanup after such time period).	29.32	14.63	43.95
302	Asbestos Abatement Worker	24.36	14.44	38.80
303	Landscaper Future Increase(s): Add \$1.60/hr on 6/1/14. Premium Increase(s): DOT PREMIUMS: 1) Pay two times the hourly basic rate on Sunday, New Year's Day, Memorial Day, Independence Day, Labor Day, Thanksgiving Day & Christmas Day. 2) Add \$1.25/hr for work on projects involving temporary traffic control setup, for lane and shoulder closures, when work under artificial illumination conditions is necessary as required by the project provisions (including prep time prior to and/or cleanup after such time period).	29.32	14.63	43.95
304	Flagperson or Traffic Control Person Future Increase(s): Add \$1.60/hr on 6/1/2014. Premium Increase(s): DOT PREMIUMS: 1) Pay two times the hourly basic rate on Sunday, New Year's Day, Memorial Day, Independence Day, Labor Day, Thanksgiving Day & Christmas Day. 2) Add \$1.25/hr when the Wisconsin Department of Transportation or responsible governing agency requires that work be performed at night under artificial illumination with traffic control and the work is completed after sunset and before sunrise.	25.67	14.63	40.30
311	Fiber Optic Laborer (Outside, Other Than Concrete Encased)	18.31	12.67	30.98
314	Railroad Track Laborer	23.46	3.30	26.76

**HEAVY EQUIPMENT OPERATORS  
AIRPORT PAVEMENT OR STATE HIGHWAY CONSTRUCTION**

Fringe Benefits Must Be Paid On All Hours Worked

<u>CODE</u>	<u>TRADE OR OCCUPATION</u>	<u>HOURLY BASIC RATE OF PAY</u> \$	<u>HOURLY FRINGE BENEFITS</u> \$	<u>TOTAL</u> \$
531	Crane, Tower Crane, Pedestal Tower or Derrick, With Boom, Leads &/or Jib Lengths Measuring 176 Ft or Over; Crane, Tower Crane, Pedestal Tower or Derrick, With or Without Attachments, With a Lifting Capacity of Over 100 Tons, Self-Erecting Tower Crane With a Lifting Capacity Of Over 4,000 Lbs., Crane With Boom Dollies; Traveling Crane (Bridge Type). Future Increase(s): Add \$1.75/hr on 6/1/2014); Add \$1.25/hr on 6/1/2015); Add \$1.30/hr on 6/1/2016); Add \$1.25/hr on 6/1/2017. Premium Increase(s): DOT PREMIUMS: 1) Pay two times the hourly basic rate on Sunday, New Year's Day, Memorial Day, Independence Day, Labor Day, Thanksgiving Day & Christmas Day. 2) Add \$1.50/hr night work premium. See DOT'S website for details about the applicability of this night work premium at: <a href="http://www.dot.wi.gov/business/civilrights/laborwages/pwc.htm">http://www.dot.wi.gov/business/civilrights/laborwages/pwc.htm</a> .	36.72	20.40	57.12
532	Backhoe (Track Type) Having a Mfgr.'s Rated Capacity of 130,000 Lbs. or Over; Caisson Rig; Crane, Tower Crane, Portable Tower, Pedestal Tower or Derrick, With Boom, Leads &/or Jib Lengths Measuring 175 Ft or Under; Crane, Tower Crane, Portable Tower, Pedestal Tower or Derrick, With or Without Attachments, With a Lifting Capacity of 100 Tons or Under, Self-Erecting Tower Crane With A Lifting Capacity Of 4,000 Lbs., & Under; Dredge (NOT Performing Work on the Great Lakes); Licensed Boat Pilot (NOT Performing Work on the Great Lakes); Pile Driver. Future Increase(s): Add \$1.75/hr on 6/1/2014); Add \$1.25/hr on 6/1/2015); Add \$1.30/hr on 6/1/2016); Add \$1.25/hr on 6/1/2017. Premium Increase(s): DOT PREMIUMS: 1) Pay two times the hourly basic rate on Sunday, New Year's Day, Memorial Day, Independence Day, Labor Day, Thanksgiving Day & Christmas Day. 2) Add \$1.50/hr night work premium. See DOT'S website for details about the applicability of this night work premium at: <a href="http://www.dot.wi.gov/business/civilrights/laborwages/pwc.htm">http://www.dot.wi.gov/business/civilrights/laborwages/pwc.htm</a> .	36.22	20.40	56.62

**Fringe Benefits Must Be Paid On All Hours Worked**

<u>CODE</u>	<u>TRADE OR OCCUPATION</u>	<u>HOURLY BASIC RATE OF PAY</u> \$	<u>HOURLY FRINGE BENEFITS</u> \$	<u>TOTAL</u> \$
533	<p>Air Track, Rotary or Percussion Drilling Machine &amp;/or Hammers, Blaster; Asphalt Heater, Planer &amp; Scarifier; Asphalt Milling Machine; Asphalt Screed; Automatic Subgrader (Concrete); Backhoe (Track Type) Having a Mfgr.'s Rated Capacity of Under 130,000 Lbs., Backhoe (Mini, 15,000 Lbs. &amp; Under); Bituminous (Asphalt) Plant &amp; Paver, Screed; Boatmen (NOT Performing Work on the Great Lakes); Boring Machine (Directional, Horizontal or Vertical); Bridge (Bidwell) Paver; Bulldozer or Endloader; Concrete Batch Plant, Batch Hopper; Concrete Breaker (Large, Auto, Vibratory/Sonic, Manual or Remote); Concrete Bump Cutter, Grinder, Planing or Grooving Machine; Concrete Conveyor System; Concrete Laser/Screed; Concrete Paver (Slipform); Concrete Pump, Concrete Conveyor (Rotec or Bidwell Type); Concrete Slipform Placer Curb &amp; Gutter Machine; Concrete Spreader &amp; Distributor; Crane (Carry Deck, Mini) or Truck Mounted Hydraulic Crane (10 Tons or Under); Crane With a Lifting Capacity of 25 Tons or Under; Forestry Equipment, Timbco, Tree Shear, Tub Grinder, Processor; Gradall (Cruz-Aire Type); Grader or Motor Patrol; Grout Pump; Hydro-Blaster (10,000 PSI or Over); Loading Machine (Conveyor); Material or Stack Hoist; Mechanic or Welder; Milling Machine; Post Hole Digger or Driver; Roller (Over 5 Ton); Scraper (Self Propelled or Tractor Drawn) 5 cu yds or More Capacity; Shoulder Widener; Sideboom; Skid Rig; Stabilizing or Concrete Mixer (Self-Propelled or 14S or Over); Straddle Carrier or Travel Lift; Tractor (Scraper, Dozer, Pusher, Loader); Tractor or Truck Mounted Hydraulic Backhoe; Trencher (Wheel Type or Chain Type); Tube Finisher; Tugger (NOT Performing Work on the Great Lakes); Winches &amp; A-Frames.</p> <p>Future Increase(s):                      Add \$1.75/hr on 6/1/2014); Add \$1.25/hr on 6/1/2015);                      Add \$1.30/hr on 6/1/2016); Add \$1.25/hr on 6/1/2017.</p> <p>Premium Increase(s):                      DOT PREMIUMS: 1) Pay two times the hourly basic rate on Sunday, New Year's Day, Memorial Day, Independence Day, Labor Day, Thanksgiving Day &amp; Christmas Day. 2) Add \$1.50/hr night work premium.                      See DOT'S website for details about the applicability of this night work premium at: <a href="http://www.dot.wi.gov/business/civilrights/laborwages/pwc.htm">http://www.dot.wi.gov/business/civilrights/laborwages/pwc.htm</a>.</p>	35.72	20.40	56.12

<b>Fringe Benefits Must Be Paid On <u>All</u> Hours Worked</b>		<b>HOURLY BASIC RATE OF PAY</b>	<b>HOURLY FRINGE BENEFITS</b>	<b>TOTAL</b>
<b>CODE</b>	<b>TRADE OR OCCUPATION</b>	<b>\$</b>	<b>\$</b>	<b>\$</b>
534	<p>Belting, Burlap, Texturing Machine; Broom or Sweeper; Compactor (Self-Propelled or Tractor Mounted, Towed &amp; Light Equipment); Concrete Finishing Machine (Road Type); Environmental Burner; Farm or Industrial Type Tractor; Fireman (Asphalt Plant, Pile Driver &amp; Derrick NOT Performing Work on the Great Lakes); Forklift; Greaser; Hoist (Tugger, Automatic); Jeep Digger; Joint Sawyer (Multiple Blade); Launch (NOT Performing Work on the Great Lakes); Lift Slab Machine; Mechanical Float; Mulcher; Power Subgrader; Robotic Tool Carrier (With or Without Attachments); Roller (Rubber Tire, 5 Ton or Under); Self Propelled Chip Spreader; Shouldering Machine; Skid Steer Loader (With or Without Attachments); Telehandler; Tining or Curing Machine.</p> <p>Future Increase(s): Add \$1.75/hr on 6/1/2014); Add \$1.25/hr on 6/1/2015); Add \$1.30/hr on 6/1/2016); Add \$1.25/hr on 6/1/2017.</p> <p>Premium Increase(s): DOT PREMIUMS: 1) Pay two times the hourly basic rate on Sunday, New Year's Day, Memorial Day, Independence Day, Labor Day, Thanksgiving Day &amp; Christmas Day. 2) Add \$1.50/hr night work premium. See DOT'S website for details about the applicability of this night work premium at: <a href="http://www.dot.wi.gov/business/civilrights/laborwages/pwc.htm">http://www.dot.wi.gov/business/civilrights/laborwages/pwc.htm</a>.</p>	35.46	20.40	55.86
535	<p>Air Compressor (&amp;/or 400 CFM or Over); Air, Electric or Hydraulic Jacking System; Augers (Vertical &amp; Horizontal); Automatic Belt Conveyor &amp; Surge Bin; Boiler (Temporary Heat); Concrete Proportioning Plant; Crusher, Screening or Wash Plant; Generator (&amp;/or 150 KW or Over); Heaters (Mechanical); High Pressure Utility Locating Machine (Daylighting Machine); Mudjack; Oiler; Prestress Machine; Pug Mill; Pump (3 Inch or Over) or Well Points; Rock, Stone Breaker; Screed (Milling Machine); Stump Chipper; Tank Car Heaters; Vibratory Hammer or Extractor, Power Pack.</p> <p>Future Increase(s): Add \$1.75/hr on 6/1/2014); Add \$1.25/hr on 6/1/2015); Add \$1.30/hr on 6/1/2016); Add \$1.25/hr on 6/1/2017.</p> <p>Premium Increase(s): DOT PREMIUMS: 1) Pay two times the hourly basic rate on Sunday, New Year's Day, Memorial Day, Independence Day, Labor Day, Thanksgiving Day &amp; Christmas Day. 2) Add \$1.50/hr night work premium. See DOT'S website for details about the applicability of this night work premium at: <a href="http://www.dot.wi.gov/business/civilrights/laborwages/pwc.htm">http://www.dot.wi.gov/business/civilrights/laborwages/pwc.htm</a>.</p>	35.17	20.40	55.57
536	Fiber Optic Cable Equipment.	26.69	16.65	43.34
537	Work Performed on the Great Lakes Including Diver; Wet Tender or Hydraulic Dredge Engineer.	38.80	20.17	58.97
538	Work Performed on the Great Lakes Including 70 Ton & Over Tug Operator; Assistant Hydraulic Dredge Engineer; Crane or Backhoe Operator; Hydraulic Dredge Leverman or Diver's Tender; Mechanic or Welder.	38.80	20.17	58.97

**Fringe Benefits Must Be Paid On All Hours Worked**

<u>CODE</u>	<u>TRADE OR OCCUPATION</u>	<u>HOURLY BASIC RATE OF PAY</u> \$	<u>HOURLY FRINGE BENEFITS</u> \$	<u>TOTAL</u> \$
539	Work Performed on the Great Lakes Including Deck Equipment Operator or Machineryman (Maintains Cranes Over 50 Tons or Backhoes 115,000 Lbs. or More); Tug, Launch or Loader, Dozer or Like Equipment When Operated on a Barge, Breakwater Wall, Slip, Dock or Scow, Deck Machinery.	34.50	20.04	54.54
540	Work Performed on the Great Lakes Including Deck Equipment Operator, Machineryman or Fireman (Operates 4 Units or More or Maintains Cranes 50 Tons or Under or Backhoes 115,000 Lbs. or Under); Deck Hand, Deck Engineer or Assistant Tug Operator; Off Road Trucks-Great Lakes ONLY.	34.50	20.04	54.54

**LOCAL STREET OR MISCELLANEOUS PAVING CONSTRUCTION**

Includes roads, streets, alleys, trails, bridges, paths, racetracks, parking lots and driveways (except residential or agricultural), public sidewalks or other similar projects (excluding projects awarded by the Wisconsin Department of Transportation).

**SKILLED TRADES**

Fringe Benefits Must Be Paid On <u>All</u> Hours Worked		HOURLY BASIC RATE OF PAY	HOURLY FRINGE BENEFITS	TOTAL
<u>CODE</u>	<u>TRADE OR OCCUPATION</u>	\$	\$	\$
103	Bricklayer, Blocklayer or Stonemason	32.01	17.35	49.36
105	Carpenter	32.93	19.93	52.86
107	Cement Finisher	31.48	15.68	47.16
109	Electrician	31.27	22.81	54.08
111	Fence Erector	24.72	0.00	24.72
116	Ironworker	31.25	19.46	50.71
118	Line Constructor (Electrical)	38.25	17.31	55.56
124	Painter	24.50	16.60	41.10
125	Pavement Marking Operator	30.00	0.00	30.00
126	Piledriver	30.98	15.90	46.88
133	Rofer or Waterproofer	29.40	6.25	35.65
137	Teledata Technician or Installer	21.89	11.85	33.74
143	Tuckpointer, Caulker or Cleaner	35.25	13.15	48.40
144	Underwater Diver (Except on Great Lakes)	38.80	20.17	58.97
150	Heavy Equipment Operator - ELECTRICAL LINE CONSTRUCTION ONLY	34.43	15.24	49.67
151	Light Equipment Operator -ELECTRICAL LINE CONSTRUCTION ONLY	30.60	14.86	45.46
152	Heavy Truck Driver - ELECTRICAL LINE CONSTRUCTION ONLY	26.78	13.63	40.41
153	Light Truck Driver - ELECTRICAL LINE CONSTRUCTION ONLY	24.86	12.97	37.83
154	Groundman - ELECTRICAL LINE CONSTRUCTION ONLY	21.75	12.70	34.45

**TRUCK DRIVERS**

Fringe Benefits Must Be Paid On <u>All</u> Hours Worked		HOURLY BASIC RATE OF PAY	HOURLY FRINGE BENEFITS	TOTAL
<u>CODE</u>	<u>TRADE OR OCCUPATION</u>	\$	\$	\$
201	Single Axle or Two Axle	30.00	15.00	45.00

**Fringe Benefits Must Be Paid On All Hours Worked**

<u>CODE</u>	<u>TRADE OR OCCUPATION</u>	<u>HOURLY BASIC RATE OF PAY</u> \$	<u>HOURLY FRINGE BENEFITS</u> \$	<u>TOTAL</u> \$
203	Three or More Axle	17.00	0.00	17.00
204	Articulated, Euclid, Dumptor, Off Road Material Hauler	32.89	18.96	51.85
205	Pavement Marking Vehicle	17.00	0.00	17.00
206	Shadow or Pilot Vehicle	30.00	15.00	45.00
207	Truck Mechanic	17.00	0.00	17.00

**LABORERS**

**Fringe Benefits Must Be Paid On All Hours Worked**

<u>CODE</u>	<u>TRADE OR OCCUPATION</u>	<u>HOURLY BASIC RATE OF PAY</u> \$	<u>HOURLY FRINGE BENEFITS</u> \$	<u>TOTAL</u> \$
301	General Laborer	28.07	13.25	41.32
303	Landscaper Future Increase(s): Add \$1.60/hr on 6/1/14. Premium Increase(s): DOT PREMIUMS: 1) Pay two times the hourly basic rate on Sunday, New Year's Day, Memorial Day, Independence Day, Labor Day, Thanksgiving Day & Christmas Day. 2) Add \$1.25/hr for work on projects involving temporary traffic control setup, for lane and shoulder closures, when work under artificial illumination conditions is necessary as required by the project provisions (including prep time prior to and/or cleanup after such time period).	29.04	14.63	43.67
304	Flagperson or Traffic Control Person	24.70	10.72	35.42
311	Fiber Optic Laborer (Outside, Other Than Concrete Encased)	18.31	12.67	30.98
314	Railroad Track Laborer	23.46	3.30	26.76

**HEAVY EQUIPMENT OPERATORS  
CONCRETE PAVEMENT OR BRIDGE WORK**

Fringe Benefits Must Be Paid On All Hours Worked

<u>CODE</u>	<u>TRADE OR OCCUPATION</u>	<u>HOURLY BASIC RATE OF PAY</u> \$	<u>HOURLY FRINGE BENEFITS</u> \$	<u>TOTAL</u> \$
541	<p>Crane, Tower Crane, Pedestal Tower or Derrick, With or Without Attachments, With a Lifting Capacity of Over 100 Tons, Self-Erecting Tower Crane With a Lifting Capacity Of Over 4,000 Lbs., Crane With Boom Dollies; Crane, Tower Crane, Pedestal Tower or Derrick, With Boom, Leads &amp;/or Jib Lengths Measuring 176 Ft or Over; Master Mechanic.</p> <p>Future Increase(s): Add \$1.75/hr on 6/1/2014); Add \$1.25/hr on 6/1/2015); Add \$1.30/hr on 6/1/2016); Add \$1.25/hr on 6/1/2017.</p> <p>Premium Increase(s): DOT PREMIUMS: 1) Pay two times the hourly basic rate on Sunday, New Year's Day, Memorial Day, Independence Day, Labor Day, Thanksgiving Day &amp; Christmas Day. 2) Add \$1.50/hr night work premium. See DOT'S website for details about the applicability of this night work premium at: <a href="http://www.dot.wi.gov/business/civilrights/laborwages/pwc.htm">http://www.dot.wi.gov/business/civilrights/laborwages/pwc.htm</a>.</p>	36.72	20.40	57.12
542	<p>Backhoe (Track Type) Having a Mfr.'s Rated Capacity of 130,000 Lbs. or Over; Caisson Rig; Crane, Tower Crane, Portable Tower, Pedestal Tower or Derrick, With or Without Attachments, With a Lifting Capacity of 100 Tons or Under, Self-Erecting Tower Crane With a Lifting Capacity of 4,000 Lbs. &amp; Under; Crane, Tower Crane Portable Tower, Pedestal Tower or Derrick, With Boom, Leads &amp;/or Jib Lengths Measuring 175 Ft or Under; Dredge (NOT Performing Work on the Great Lakes); Licensed Boat Pilot (NOT Performing Work on the Great Lakes); Pile Driver.</p> <p>Future Increase(s): Add \$1.75/hr on 6/1/2014); Add \$1.25/hr on 6/1/2015); Add \$1.30/hr on 6/1/2016); Add \$1.25/hr on 6/1/2017.</p> <p>Premium Increase(s): DOT PREMIUMS: 1) Pay two times the hourly basic rate on Sunday, New Year's Day, Memorial Day, Independence Day, Labor Day, Thanksgiving Day &amp; Christmas Day. 2) Add \$1.50/hr night work premium. See DOT'S website for details about the applicability of this night work premium at: <a href="http://www.dot.wi.gov/business/civilrights/laborwages/pwc.htm">http://www.dot.wi.gov/business/civilrights/laborwages/pwc.htm</a>.</p>	36.22	20.40	56.62



Fringe Benefits Must Be Paid On All Hours Worked

<u>CODE</u>	<u>TRADE OR OCCUPATION</u>	<u>HOURLY BASIC RATE OF PAY</u> \$	<u>HOURLY FRINGE BENEFITS</u> \$	<u>TOTAL</u> \$
543	<p>Air Track, Rotary or Percussion Drilling Machine &amp;/or Hammers, Blaster; Automatic Subgrader (Concrete); Backhoe (Track Type) Having a Mfgr.'s Rated Capacity of Under 130,000 Lbs., Backhoe (Mini, 15,000 Lbs. &amp; Under); Boring Machine (Directional, Horizontal or Vertical); Bridge (Bidwell) Paver; Bulldozer or Endloader; Concrete Batch Plant, Batch Hopper; Concrete Breaker (Large, Auto, Vibratory/Sonic, Manual or Remote); Concrete Bump Cutter, Grinder, Planing or Grooving Machine; Concrete Conveyor System; Concrete Laser/Screed; Concrete Paver (Slipform); Concrete Pump, Concrete Conveyor (Rotec or Bidwell Type); Concrete Slipform Placer Curb &amp; Gutter Machine; Concrete Spreader &amp; Distributor; Crane (Carry Deck, Mini) or Truck Mounted Hydraulic Crane (10 Tons or Under); Crane With a Lifting Capacity of 25 Tons or Under; Forestry Equipment, Timbco, Tree Shear, Tub Grinder, Processor; Gradall (Cruz-Aire Type); Grader or Motor Patrol; Grout Pump; Hydro-Blaster (10,000 PSI or Over); Loading Machine (Conveyor); Manhoist; Material or Stack Hoist; Mechanic or Welder; Milling Machine; Post Hole Digger or Driver; Scraper (Self Propelled or Tractor Drawn) 5 cu yds or More Capacity; Shoulder Widener; Sideboom; Skid Rig; Stabilizing or Concrete Mixer (Self-Propelled or 14S or Over); Straddle Carrier or Travel Lift; Tractor (Scraper, Dozer, Pusher, Loader); Tractor or Truck Mounted Hydraulic Backhoe; Trencher (Wheel Type or Chain Type); Tube Finisher; Tugger (NOT Performing Work on the Great Lakes); Winches &amp; A-Frames.</p> <p>Future Increase(s):            Add \$1.75/hr on 6/1/2014); Add \$1.25/hr on 6/1/2015);            Add \$1.30/hr on 6/1/2016); Add \$1.25/hr on 6/1/2017.</p> <p>Premium Increase(s):            DOT PREMIUMS: 1) Pay two times the hourly basic rate on Sunday, New Year's Day, Memorial Day, Independence Day, Labor Day, Thanksgiving Day &amp; Christmas Day. 2) Add \$1.50/hr night work premium.            See DOT'S website for details about the applicability of this night work premium at: <a href="http://www.dot.wi.gov/business/civilrights/laborwages/pwc.htm">http://www.dot.wi.gov/business/civilrights/laborwages/pwc.htm</a>.</p>	35.72	20.40	56.12
544	<p>Backfiller; Belting, Burlap, Texturing Machine; Broom or Sweeper; Compactor (Self-Propelled or Tractor Mounted, Towed &amp; Light Equipment); Concrete Finishing Machine (Road Type); Environmental Burner; Farm or Industrial Type Tractor; Fireman (Pile Driver &amp; Derrick NOT Performing Work on the Great Lakes); Forklift; Greaser; Jeep Digger; Joint Sawyer (Multiple Blade); Launch (NOT Performing Work on the Great Lakes); Lift Slab Machine; Mechanical Float; Mulcher; Power Subgrader; Robotic Tool Carrier (With or Without Attachments); Self Propelled Chip Spreader; Shouldering Machine; Skid Steer Loader (With or Without Attachments); Telehandler; Tining or Curing Machine.</p>	33.96	19.79	53.75
545	<p>Air Compressor (&amp;/or 400 CFM or Over); Air, Electric or Hydraulic Jacking System; Automatic Belt Conveyor &amp; Surge Bin; Boiler (Temporary Heat); Concrete Proportioning Plant; Crusher, Screening or Wash Plant; Generator (&amp;/or 150 KW or Over); Heaters (Mechanical); High Pressure Utility Locating Machine (Daylighting Machine); Mudjack; Oiler; Prestress Machine; Pug Mill; Pump (3 Inch or Over) or Well Points; Rock, Stone Breaker; Screed (Milling Machine); Stump Chipper; Tank Car Heaters; Vibratory Hammer or Extractor, Power Pack.</p>	30.32	18.46	48.78
546	Fiber Optic Cable Equipment.	26.69	16.65	43.34

<b>Fringe Benefits Must Be Paid On <u>All</u> Hours Worked</b>				
<b>CODE</b>	<b>TRADE OR OCCUPATION</b>	<b>HOURLY BASIC RATE OF PAY</b>	<b>HOURLY FRINGE BENEFITS</b>	<b>TOTAL</b>
		\$	\$	\$
547	Work Performed on the Great Lakes Including Diver; Wet Tender or Hydraulic Dredge Engineer.	38.80	20.17	58.97
548	Work Performed on the Great Lakes Including 70 Ton & Over Tug Operator; Assistant Hydraulic Dredge Engineer; Crane or Backhoe Operator; Hydraulic Dredge Leverman or Diver's Tender; Mechanic or Welder.	38.80	20.17	58.97
549	Work Performed on the Great Lakes Including Deck Equipment Operator or Machineryman (Maintains Cranes Over 50 Tons or Backhoes 115,000 Lbs. or more); Tug, Launch or Loader, Dozer or Like Equipment When Operated on a Barge, Breakwater Wall, Slip, Dock or Scow, Deck Machinery.	34.50	20.04	54.54
550	Work Performed on the Great Lakes Including Deck Equipment Operator; Machineryman or Fireman (Operates 4 Units or More or Maintains Cranes 50 Tons or Under or Backhoes 115,000 Lbs. or Under); Deck Hand, Deck Engineer or Assistant Tug Operator; Off Road Trucks - Great Lakes ONLY.	34.50	20.04	54.54

**HEAVY EQUIPMENT OPERATORS  
ASPHALT PAVEMENT OR OTHER WORK**

<b>Fringe Benefits Must Be Paid On <u>All</u> Hours Worked</b>				
<b>CODE</b>	<b>TRADE OR OCCUPATION</b>	<b>HOURLY BASIC RATE OF PAY</b>	<b>HOURLY FRINGE BENEFITS</b>	<b>TOTAL</b>
		\$	\$	\$
551	Crane, Tower Crane, Pedestal Tower or Derrick, With or Without Attachments, With a Lifting Capacity of Over 100 Tons, Self Erecting Tower Crane With a Lifting Capacity of Over 4,000 Lbs., Crane With Boom Dollies; Crane, Tower Crane, Pedestal Tower or Derrick, With Boom, Leads and/or Jib Lengths Measuring 176 Ft or Over; Master Mechanic.	35.12	18.46	53.58
552	Backhoe (Track Type) Having a Mfgr.'s Rated Capacity of 130,000 Lbs. or Over; Caisson Rig; Crane, Tower Crane, Portable Tower, Pedestal Tower or Derrick, With or Without Attachments, With a Lifting Capacity of 100 Tons or Under, Self-Erecting Tower Crane With a Lifting Capacity Of 4,000 Lbs. & Under; Crane, Tower Crane, Portable Tower, Pedestal Tower or Derrick, With Boom, Leads &/or Jib Lengths Measuring 175 Ft or Under; Dredge (NOT Performing Work on the Great Lakes); Licensed Boat Pilot (NOT Performing Work on the Great Lakes); Pile Driver. Future Increase(s): Add \$1.75/hr on 6/1/2014); Add \$1.25/hr on 6/1/2015); Add \$1.30/hr on 6/1/2016); Add \$1.25/hr on 6/1/2017. Premium Increase(s): DOT PREMIUMS: 1) Pay two times the hourly basic rate on Sunday, New Year's Day, Memorial Day, Independence Day, Labor Day, Thanksgiving Day & Christmas Day. 2) Add \$1.50/hr night work premium. See DOT'S website for details about the applicability of this night work premium at: <a href="http://www.dot.wi.gov/business/civilrights/laborwages/pwc.htm">http://www.dot.wi.gov/business/civilrights/laborwages/pwc.htm</a> .	36.22	20.40	56.62

Fringe Benefits Must Be Paid On All Hours Worked

<u>CODE</u>	<u>TRADE OR OCCUPATION</u>	<u>HOURLY BASIC RATE OF PAY</u> \$	<u>HOURLY FRINGE BENEFITS</u> \$	<u>TOTAL</u> \$
553	Air, Track, Rotary or Percussion Drilling Machine &/or Hammers, Blaster; Asphalt Heater, Planer & Scarifier; Asphalt Milling Machine; Asphalt Screed; Backhoe (Track Type) Having a Mfr.'s Rated Capacity of Under 130,000 Lbs., Backhoe (Mini, 15,000 Lbs. & Under); Bituminous (Asphalt) Plant & Paver, Screed; Boring Machine (Directional, Horizontal or Vertical); Bulldozer or Endloader; Concrete Breaker (Large, Auto, Vibratory/Sonic, Manual or Remote); Concrete Conveyor System; Concrete Laser/Screed; Concrete Slipform Placer Curb & Gutter Machine; Crane (Carry Deck, Mini) or Truck Mounted Hydraulic Crane (10 Tons or Under); Crane With a Lifting Capacity of 25 Tons or Under; Forestry Equipment, Timbco, Tree Shear, Tub Grinder, Processor; Gradall (Cruz-Aire Type); Grader or Motor Patrol; Hydro-Blaster (10,000 PSI or Over); Loading Machine (Conveyor); Manhoist; Material or Stack Hoist; Mechanic or Welder; Milling Machine; Post Hole Digger or Driver; Railroad Track Rail Leveling Machine, Tie Placer, Extractor, Tamper, Stone Leveler or Rehabilitation Equipment; Roller (Over 5 Ton); Scraper (Self Propelled or Tractor Drawn) 5 cu yds or More Capacity; Shoulder Widener; Sideboom; Skid Rig; Stabilizing or Concrete Mixer (Self-Propelled or 14S or Over); Tractor (Scraper, Dozer, Pusher, Loader); Tractor or Truck Mounted Hydraulic Backhoe; Trencher (Wheel Type or Chain Type); Tube Finisher; Tugger (NOT Performing Work on the Great Lakes); Winches & A-Frames.	32.89	18.96	51.85
554	Backfiller; Broom or Sweeper; Compactor (Self-Propelled or Tractor Mounted, Towed & Light Equipment); Concrete Finishing Machine (Road Type); Environmental Burner; Farm or Industrial Type Tractor; Fireman (Asphalt Plant, Pile Driver & Derrick NOT Performing Work on the Great Lakes); Forklift; Greaser; Hoist (Tugger, Automatic); Jeep Digger; Joint Sawyer (Multiple Blade); Launch (NOT Performing Work on the Great Lakes); Lift Slab Machine; Mechanical Float; Mulcher; Power Subgrader; Robotic Tool Carrier (With or Without Attachments); Roller (Rubber Tire, 5 Ton or Under); Self-Propelled Chip Spreader; Shouldering Machine; Skid Steer Loader (With or Without Attachments); Telehandler.	33.67	19.48	53.15
555	Air Compressor (&/or 400 CFM or Over); Air, Electric or Hydraulic Jacking System; Augers (Vertical & Horizontal); Automatic Belt Conveyor & Surge Bin; Boiler (Temporary Heat); Crusher, Screening or Wash Plant; Generator (&/or 150 KW or Over); Heaters (Mechanical); High Pressure Utility Locating Machine (Daylighting Machine); Mudjack; Oiler; Prestress Machine; Pug Mill; Pump (3 Inch or Over) or Well Points; Rock, Stone Breaker; Screed (Milling Machine); Stump Chipper; Tank Car Heaters; Vibratory Hammer or Extractor, Power Pack. Future Increase(s): Add \$1.75/hr on 6/1/2014); Add \$1.25/hr on 6/1/2015); Add \$1.30/hr on 6/1/2016); Add \$1.25/hr on 6/1/2017. Premium Increase(s): DOT PREMIUMS: 1) Pay two times the hourly basic rate on Sunday, New Year's Day, Memorial Day, Independence Day, Labor Day, Thanksgiving Day & Christmas Day. 2) Add \$1.50/hr night work premium. See DOT'S website for details about the applicability of this night work premium at: <a href="http://www.dot.wi.gov/business/civilrights/laborwages/pwc.htm">http://www.dot.wi.gov/business/civilrights/laborwages/pwc.htm</a> .	35.17	20.40	55.57
556	Fiber Optic Cable Equipment.	26.69	16.65	43.34

**RESIDENTIAL OR AGRICULTURAL CONSTRUCTION**

Includes single family houses or apartment buildings of no more than four (4) stories in height and all buildings, structures or facilities that are primarily used for agricultural or farming purposes, excluding commercial buildings. For classification purposes, the exterior height of a residential building, in terms of stories, is the primary consideration. All incidental items such as site work, driveways, parking lots, private sidewalks, private septic systems or sewer and water laterals connected to a public system and swimming pools are included within this definition. Residential buildings of five (5) stories and above are NOT included within this definition.

**SKILLED TRADES**

<b>Fringe Benefits Must Be Paid On <u>All</u> Hours Worked</b>		<b>HOURLY BASIC RATE OF PAY</b>	<b>HOURLY FRINGE BENEFITS</b>	<b>TOTAL</b>
<b>CODE</b>	<b>TRADE OR OCCUPATION</b>	<b>\$</b>	<b>\$</b>	<b>\$</b>
101	Acoustic Ceiling Tile Installer Future Increase(s): Add \$1.25/hr on 6/2/2014.	33.68	19.81	53.49
102	Boilermaker	26.00	4.73	30.73
103	Bricklayer, Blocklayer or Stonemason	32.01	13.26	45.27
104	Cabinet Installer	22.00	1.05	23.05
105	Carpenter	30.48	3.24	33.72
106	Carpet Layer or Soft Floor Coverer	23.68	3.20	26.88
107	Cement Finisher	20.93	5.94	26.87
108	Drywall Taper or Finisher	22.50	0.88	23.38
109	Electrician	27.50	7.47	34.97
110	Elevator Constructor	42.86	23.84	66.70
111	Fence Erector	18.52	4.89	23.41
112	Fire Sprinkler Fitter	52.82	5.54	58.36
113	Glazier	38.03	13.42	51.45
114	Heat or Frost Insulator	30.00	0.00	30.00
115	Insulator (Batt or Blown)	19.00	14.33	33.33
116	Ironworker	31.25	19.46	50.71
117	Lather	30.48	3.24	33.72
119	Marble Finisher	26.89	19.18	46.07
120	Marble Mason	32.01	13.26	45.27
121	Metal Building Erector	17.00	3.82	20.82
123	Overhead Door Installer	12.00	0.00	12.00
124	Painter	20.00	4.22	24.22

<b>Fringe Benefits Must Be Paid On <u>All</u> Hours Worked</b>		<b>HOURLY BASIC RATE OF PAY</b>	<b>HOURLY FRINGE BENEFITS</b>	<b>TOTAL</b>
<b>CODE</b>	<b>TRADE OR OCCUPATION</b>	<b>\$</b>	<b>\$</b>	<b>\$</b>
125	Pavement Marking Operator	30.00	0.00	30.00
129	Plasterer	25.00	0.00	25.00
130	Plumber	30.00	10.62	40.62
132	Refrigeration Mechanic	19.75	8.56	28.31
133	Roofer or Waterproofer	17.00	3.72	20.72
134	Sheet Metal Worker	21.03	3.40	24.43
135	Steamfitter	31.72	16.10	47.82
137	Teledata Technician or Installer	24.75	8.09	32.84
138	Temperature Control Installer	22.50	0.70	23.20
139	Terrazzo Finisher	26.89	19.18	46.07
140	Terrazzo Mechanic	30.20	18.42	48.62
141	Tile Finisher	23.77	16.50	40.27
142	Tile Setter	21.00	0.00	21.00
143	Tuckpointer, Caulker or Cleaner	32.50	0.02	32.52
146	Well Driller or Pump Installer	27.60	5.80	33.40
147	Siding Installer	20.18	0.00	20.18

**TRUCK DRIVERS**

<b>Fringe Benefits Must Be Paid On <u>All</u> Hours Worked</b>		<b>HOURLY BASIC RATE OF PAY</b>	<b>HOURLY FRINGE BENEFITS</b>	<b>TOTAL</b>
<b>CODE</b>	<b>TRADE OR OCCUPATION</b>	<b>\$</b>	<b>\$</b>	<b>\$</b>
201	Single Axle or Two Axle	28.05	4.16	32.21
203	Three or More Axle	18.00	2.37	20.37
205	Pavement Marking Vehicle	18.00	2.37	20.37
207	Truck Mechanic	19.00	1.85	20.85

**LABORERS**

<b>Fringe Benefits Must Be Paid On <u>All</u> Hours Worked</b>		<b>HOURLY BASIC RATE OF PAY</b>	<b>HOURLY FRINGE BENEFITS</b>	<b>TOTAL</b>
<b>CODE</b>	<b>TRADE OR OCCUPATION</b>	<b>\$</b>	<b>\$</b>	<b>\$</b>
301	General Laborer	18.14	10.16	28.30
302	Asbestos Abatement Worker	17.00	3.86	20.86

<b>Fringe Benefits Must Be Paid On <u>All</u> Hours Worked</b>		<b>HOURLY BASIC RATE OF PAY</b>	<b>HOURLY FRINGE BENEFITS</b>	<b>TOTAL</b>
<b>CODE</b>	<b>TRADE OR OCCUPATION</b>	<b>\$</b>	<b>\$</b>	<b>\$</b>
303	Landscaper	30.00	0.00	30.00
311	Fiber Optic Laborer (Outside, Other Than Concrete Encased)	18.31	12.67	30.98
315	Final Construction Clean-Up Worker	16.00	0.00	16.00

**HEAVY EQUIPMENT OPERATORS  
RESIDENTIAL OR AGRICULTURAL CONSTRUCTION**

<b>Fringe Benefits Must Be Paid On <u>All</u> Hours Worked</b>		<b>HOURLY BASIC RATE OF PAY</b>	<b>HOURLY FRINGE BENEFITS</b>	<b>TOTAL</b>
<b>CODE</b>	<b>TRADE OR OCCUPATION</b>	<b>\$</b>	<b>\$</b>	<b>\$</b>
557	Asphalt Heater, Planer & Scarifier; Asphalt Milling Machine; Asphalt Screed; Backhoe (Track Type); Backhoe (Mini, 15,000 Lbs. & Under); Bituminous (Asphalt) Plant & Paver, Screed; Boring Machine (Directional, Horizontal or Vertical); Bulldozer or Endloader; Concrete Breaker (Large, Auto, Vibratory/Sonic, Manual or Remote); Concrete Bump Cutter, Grinder, Planing or Grooving Machine; Concrete Conveyor System; Concrete Laser/Screed; Concrete Paver (Slipform); Concrete Pump, Concrete Conveyor (Rotec or Bidwell Type); Concrete Slipform Placer Curb & Gutter Machine; Concrete Spreader & Distributor; Crane (Carry Deck, Mini) or Truck Mounted Hydraulic Crane (10 Tons or Under); Crane With a Lifting Capacity of 25 Tons or Under; Crane, Shovel, Dragline, Clamshells; Forestry Equipment, TImbco, Tree Shear, Tub Grinder, Processor; Grader or Motor Patrol; Grout Pump; Hydro-Blaster (10,000 PSI or Over); Loading Machine (Conveyor); Manhoist; Material or Stack Hoist; Mechanic or Welder; Milling Machine; Roller (Over 5 Ton); Scraper (Self Propelled or Tractor Drawn) 5 cu yds or More Capacity; Shoulder Widener; Skid Rig; Stabilizing or Concrete Mixer (Self-Propelled or 14S or Over); Tractor (Scraper, Dozer, Pusher, Loader); Tractor or Truck Mounted Hydraulic Backhoe; Tractor or Truck Mounted Hydraulic Crane (10 Tons or Under); Trencher (Wheel Type or Chain Type); Winches & A-Frames.	29.70	20.08	49.78
558	Air Compressor (&/or 400 CFM or Over); Air, Electric or Hydraulic Jacking System; Backfiller; Belting, Burlap, Texturing Machine; Boiler (Temporary Heat); Broom or Sweeper; Compactor (Self-Propelled or Tractor Mounted, Towed & Light Equipment); Concrete Finishing Machine (Road Type); Farm or Industrial Type Tractor; Forklift; Generator (&/or 150 KW or Over); Heaters (Mechanical); High Pressure Utility Locating Machine (Daylighting Machine); Jeep Digger; Lift Slab Machine; Mulcher; Oiler; Post Hole Digger or Driver; Power Subgrader; Pump (3 Inch or Over) or Well Points; Robotic Tool Carrier (With or Without Attachments); Rock, Stone Breaker; Roller (Rubber Tire, 5 Tons or Under); Screed (Milling Machine); Self Propelled Chip Spreader; Shouldering Machine; Skid Steer Loader (With or Without Attachments); Stump Chipper; Telehandler; Vibratory Hammer or Extractor, Power Pack.	29.70	16.00	45.70

\*\*\*\*\* END OF RATES \*\*\*\*\*