

NOTES:

- * A PAVEMENT DESIGN IN ACCORDANCE WITH STANDARD DETAIL DRAWING 4.06 IS REQUIRED ON ALL PROJECTS
- **3" OF CRUSHED AGGREGATE BASE COURSE GRADATION 3 SHALL BE PLACED UNDER THE SIDEWALK WHERE THE CENTERLINE GRADE OF THE STREET EXCEEDS 5%

***CITY OF MADISON MINIMUM PAVEMENT DESIGN**

TYPE	CRUSHED AGGREGATE BASE COURSE		ASPHALTIC CONCRETE PAVEMENT	
	LOWER LAYER GRADATION 1	UPPER LAYER GRADATION 2	LOWER LAYER TYPE	UPPER LAYER TYPE
A	6"	4"	E-0.3	E-0.3
B	6"	4"	E-1	E-1
C	6"	4"	E-3	E-3

CITY OF MADISON
ENGINEERING DIVISION

**TYPICAL SECTION
32' STREET**

STANDARD DETAIL DRAWING 4.01

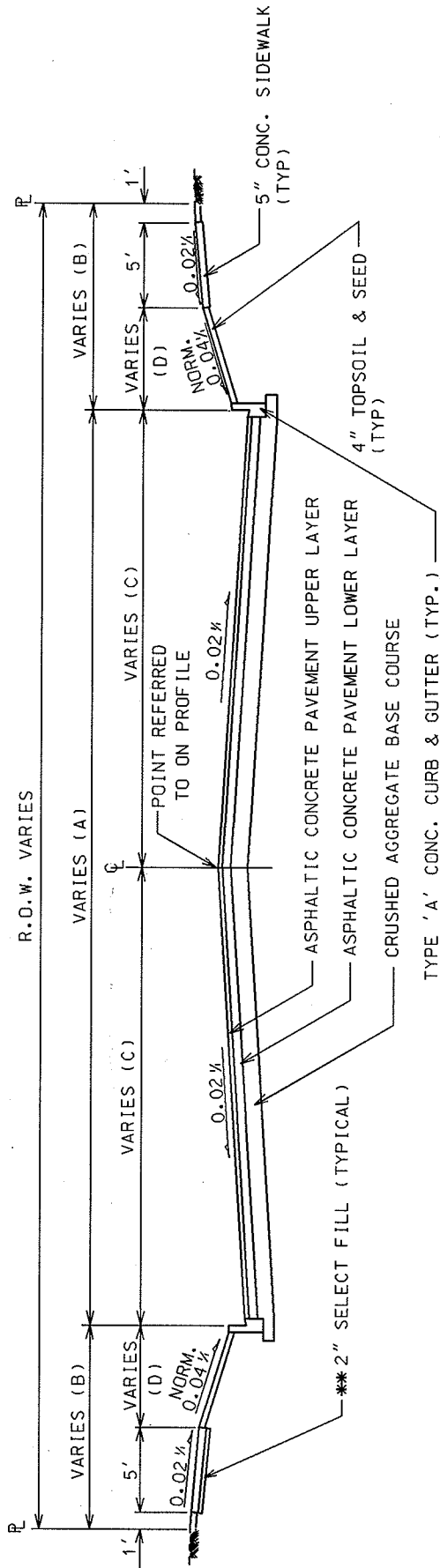

TYPICAL DIMENSIONS

R.O.W.	A	B	C	D
60	32	14	16	8
66	36	15	18	9
66	40	13	20	7
80	44	18	22	12
80	54	13	27	7

NOTES:

* A PAVEMENT DESIGN IN ACCORDANCE WITH STANDARD DETAIL DRAWING 4.06 IS REQUIRED ON ALL PROJECTS

**3" OF CRUSHED AGGREGATE BASE COURSE GRADATION 3 SHALL BE PLACED UNDER THE SIDEWALK WHERE THE CENTERLINE GRADE OF THE STREET EXCEEDS 5%

*** CITY OF MADISON MINIMUM PAVEMENT DESIGN**

TYPE	CRUSHED AGGREGATE BASE COURSE		ASPHALTIC CONCRETE PAVEMENT	
	LOWER LAYER GRADATION 1	UPPER LAYER GRADATION 2	LOWER LAYER TYPE	UPPER LAYER TYPE
A	6"	4"	E-0.3	E-0.3
B	6"	4"	E-1	E-1
C	6"	4"	E-3	E-3

2004

CITY OF MADISON
ENGINEERING DIVISION

**TYPICAL SECTION
VARIOUS WIDTH STREETS**

STANDARD DETAIL DRAWING 4.02

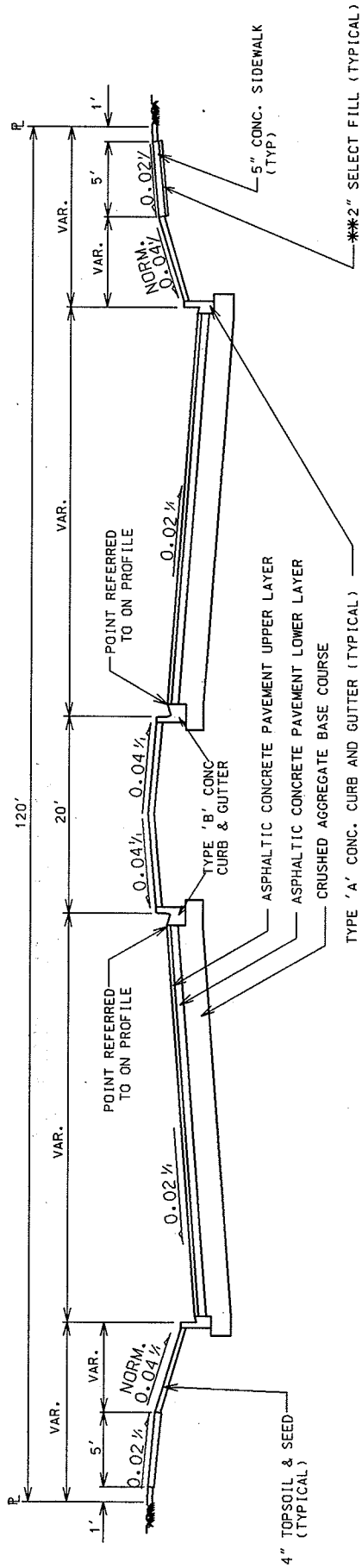

NOTES:

* A PAVEMENT DESIGN IN ACCORDANCE WITH STANDARD
DETAIL DRAWING 4.06 IS REQUIRED ON ALL PROJECTS

** 3" OF CRUSHED AGGREGATE BASE COURSE GRADATION 3
SHALL BE PLACED UNDER THE SIDEWALK WHERE THE
CENTERLINE GRADE OF THE STREET EXCEEDS 5%

***CITY OF MADISON MINIMUM PAVEMENT DESIGN**

TYPE	CRUSHED AGGREGATE BASE COURSE		ASPHALTIC CONCRETE PAVEMENT	
	LOWER LAYER GRADATION 1	UPPER LAYER GRADATION 2	LOWER LAYER TYPE	UPPER LAYER THICKNESS
A	6"	4"	E-0.3	1.75"
B	6"	4"	E-1	1.75"
C	6"	4"	E-3	1.75"

2004

CITY OF MADISON
ENGINEERING DIVISION

**TYPICAL SECTION
BOULEVARD STREET**

STANDARD DETAIL DRAWING 4.03

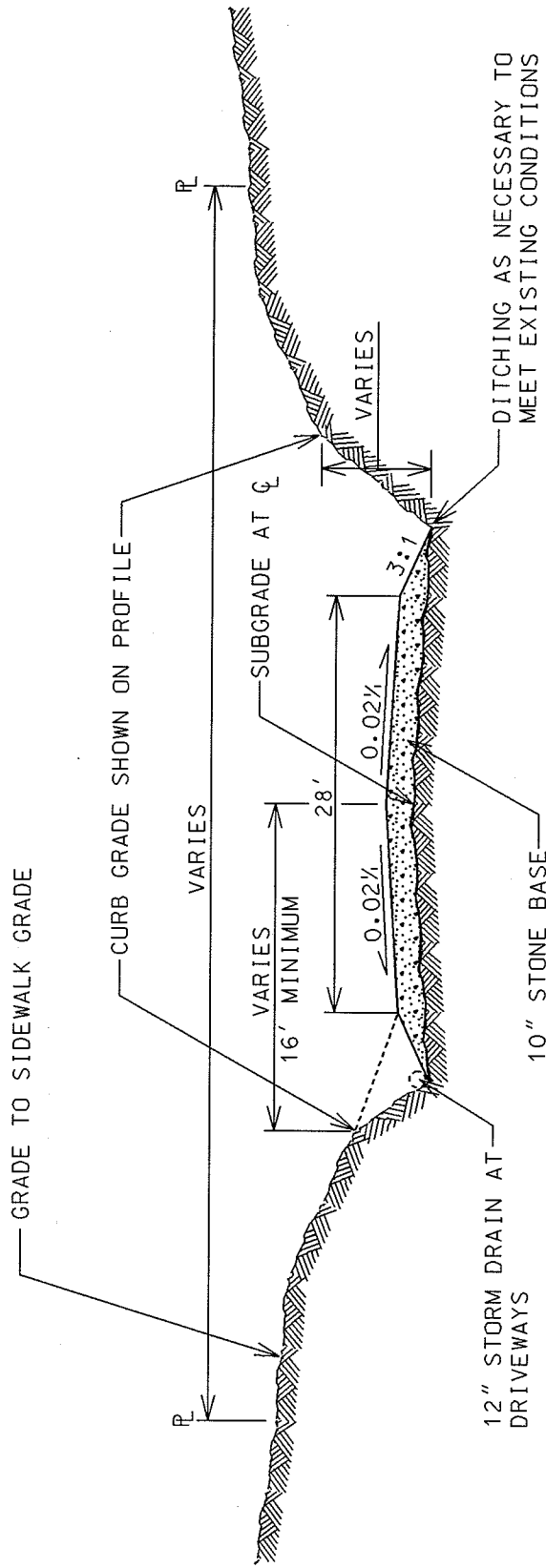

DITCHING AS NECESSARY TO MEET EXISTING CONDITIONS

GENERAL NOTES:

SUBGRADE SHALL BE CONSTRUCTED IN ACCORDANCE WITH CITY OF MADISON STANDARD SPECIFICATIONS. TERRACES AND SIDESLOPES SHALL BE TOPSOILED, SEEDED, FERTILIZED AND MULCHED IN ACCORDANCE WITH THE SPECIFICATIONS

2004

CITY OF MADISON
ENGINEERING DIVISION

**TYPICAL SECTION
TEMPORARY STREET**

STANDARD DETAIL DRAWING 4.04

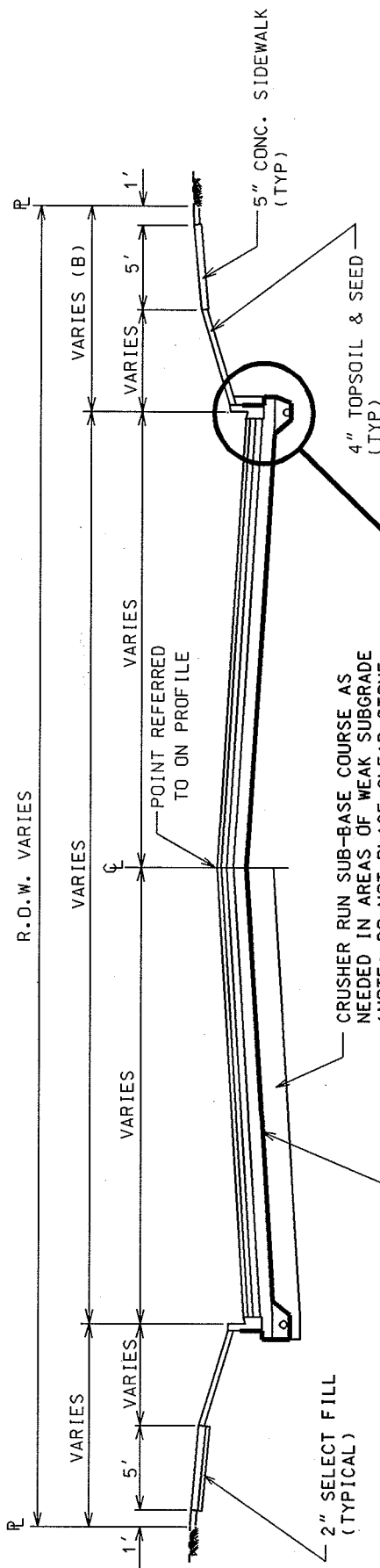

CRUSHER RUN SUB-BASE COURSE AS NEEDED IN AREAS OF WEAK SUBGRADE (NOTE: DO NOT PLACE CLEAR STONE IN UNDERCUT AREAS).

TYPE 'A' CONC. CURB & GUTTER (TYPICAL)

FILL (INCIDENTAL)

OPEN GRADED BASE COURSE (TYP) WI DOT GRADATION NO.2 AS SPECIFIED IN SECTION 501.2.5.4.4 OF WI DOT STANDARD SPECIFICATIONS

ASPHALTIC CONC PAVEMENT UPPER LAYER
 ASPHALTIC CONC PAVEMENT LOWER LAYER
 CRUSHED AGG. BASE COURSE (GRADATION #2)
 CLEAR STONE BASE COURSE (GRADATION #1)

GEOTEXTILE FABRIC, WI-DOT TYPE SAS (NON-WOVEN) ENTIRE STREET IN AREAS OF UNDERDRAIN

2" SELECT FILL (TYPICAL)

45°

8" MIN.

3'

6" PERFORATED PIPE UNDERDRAIN, WRAPPED (TYP) PER SECTION 612 OF WI DOT STANDARD SPECIFICATIONS CENTER PIPE UNDER CURB AND GUTTER

GEOTEXTILE FABRIC WI DOT TYPE SAS (NON-WOVEN). FABRIC ACROSS FULL WIDTH OF ROAD AND WRAPPED UP BACK OF CURB

4" TOPSOIL & SEED (TYP)

5" CONC. SIDEWALK (TYP)

2004

CITY OF MADISON
 ENGINEERING DIVISION

TYPICAL SECTION
 WITH UNDERDRAINS

STANDARD DETAIL DRAWING 4.05

PAVEMENT DESIGN CRITERIA

Identification of roadway classification for pavement design.

Type A - Local street with low traffic volume.

Type B - Collector Type streets or any streets expected to become bus routes (Design Year $DLT \leq 2500$).

Type C - Arterial Type streets - all streets expected to carry significant truck traffic (Design Year $DLT > 2500$).

A.) Design procedure Type A roadway - use greater of:

1. The Standard Minimum Section:
3.25" Asphaltic Pavement
10" Crushed Aggregate Base Course
2. Pavement design based on Section 14-10-5 of the Wisconsin Department of Transportation's Facilities Development Manual. Use serviceability index (Pt) = 2.5, ESAL = 10 18K per day, and the soil support value given the existing field conditions. The Minimum Section is based on the above parameters and a soil support value of 3.5.

B.) Design Procedure Type B roadway - use greater of:

1. The Standard Minimum Section:
4.25" Asphaltic Pavement
10" Crushed Aggregate Base Course
2. Pavement design based on Section 14-10-5 of the Wisconsin Department of Transportation's Facilities Development Manual. Use serviceability index (Pt) = 2.5, ESAL = 20 18K per day, and the soil support value given the existing field conditions. The Minimum Section is based on the above parameters and a soil support value of 3.5.

C.) Design Procedure Type C roadway - use greater of:

1. The Standard Minimum Section:
5.25" Asphaltic Pavement
10" Crushed Aggregate Base Course
2. Pavement design based on Section 14-10-5 of the Wisconsin Department of Transportation's Facilities Development Manual. Use serviceability index (Pt) = 2.5, and the soil support value given the existing field conditions. The ESAL shall be calculated based on Section 14-1-5.

2004

CITY OF MADISON
ENGINEERING DIVISION

PAVEMENT DESIGN
CRITERIA

STANDARD DETAIL DRAWING 4.06

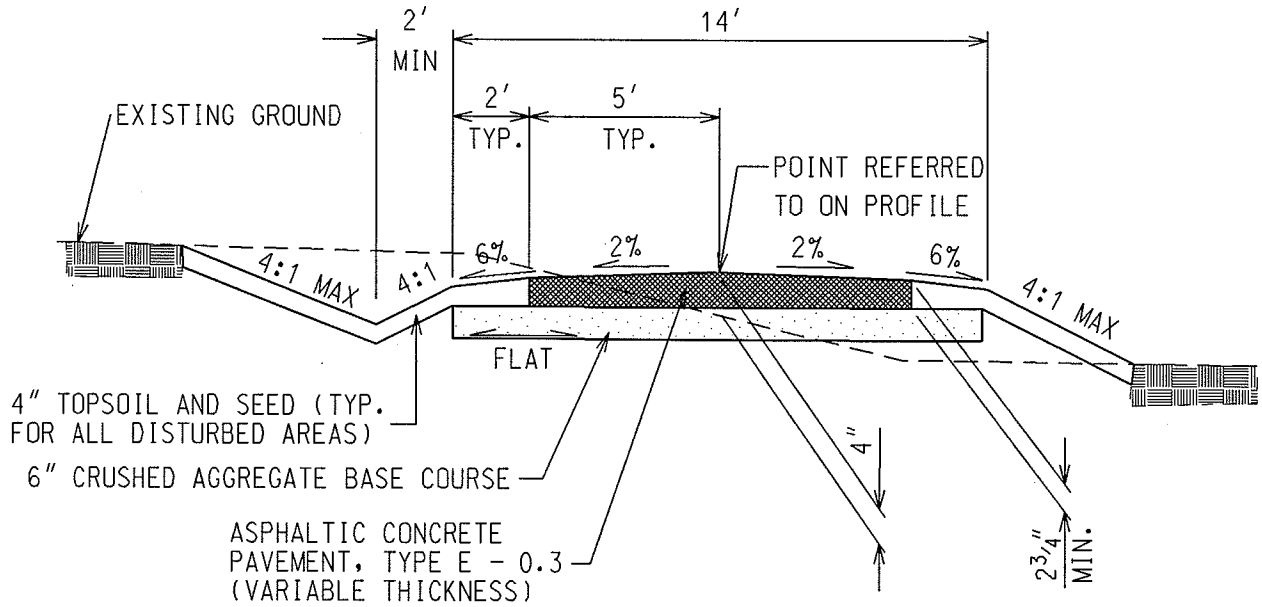

CROWNED PAVEMENT

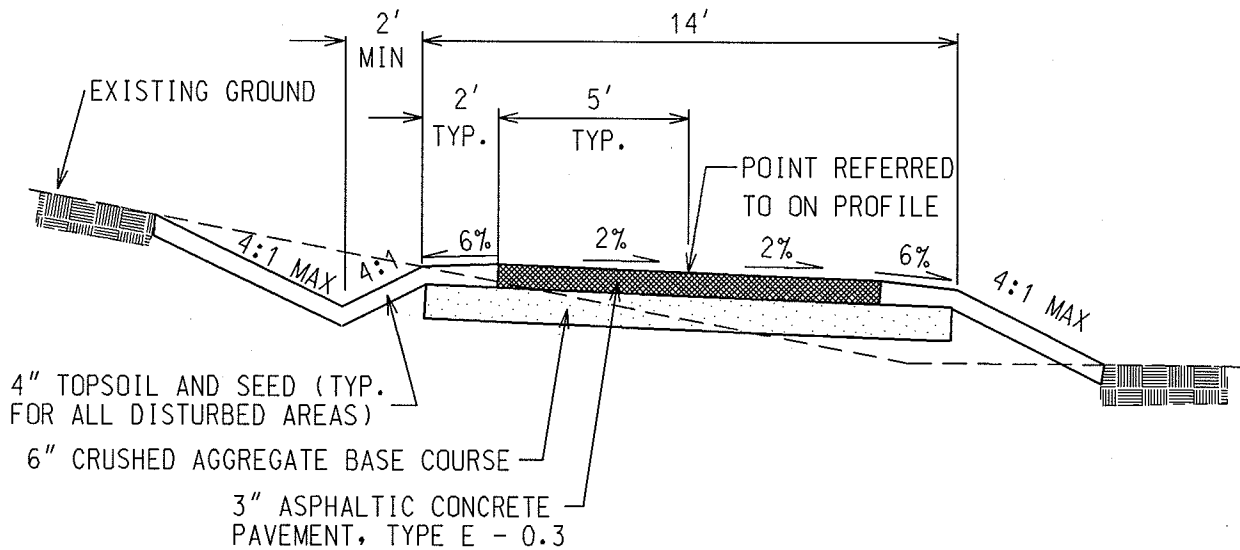

UNIFORM CROSS SLOPE

2004

GENERAL NOTES:

1. GRADING SHALL INCLUDE REMOVING VEGETATION AND TOPSOIL, SHAPING AND COMPACTING THE SUBBASE.
2. SUITABLE FILL AS REQUIRED TO OBTAIN A SUITABLE CROSS SECTION SHALL BE PLACED AND COMPACTED IN 6 INCH MAXIMUM LIFTS.
3. ALL DISTURBED AREAS SHALL BE TOPSOILED AND SEEDED.

CITY OF MADISON ENGINEERING DIVISION
TYPICAL SECTION BIKE PATH
STANDARD DETAIL DRAWING 4.07

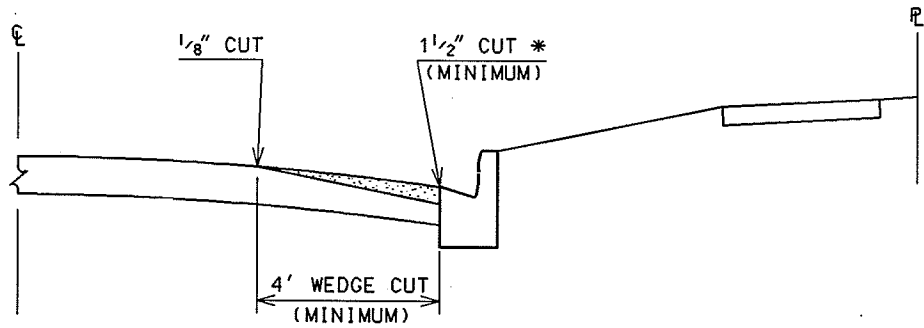

DETAIL "A"
WEDGE CUT

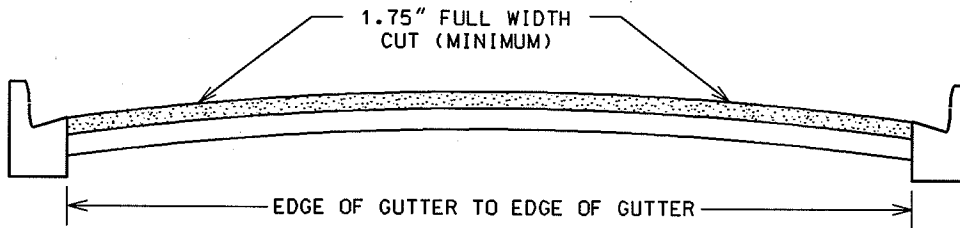

DETAIL "B"
FULL WIDTH CUT

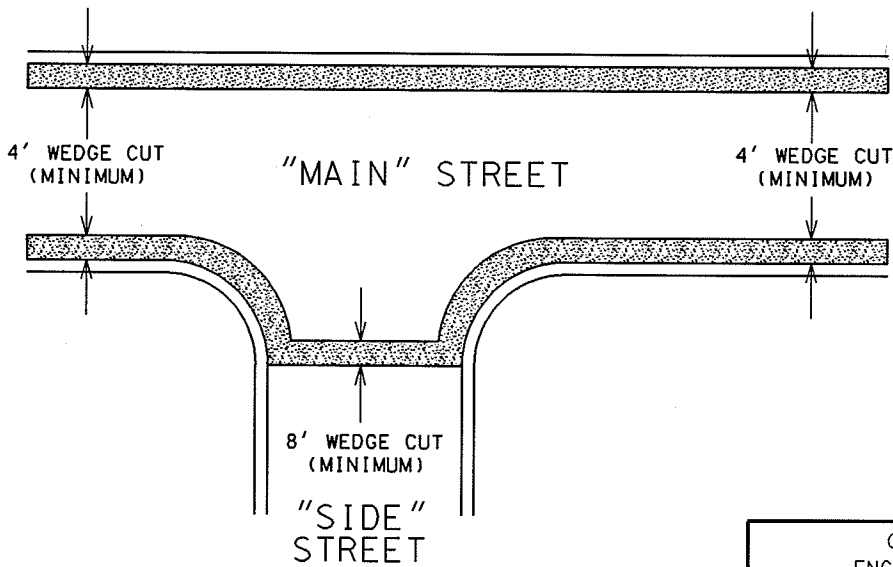

DETAIL "C"
RADIUS RETURN CUTS

2004

CITY OF MADISON
ENGINEERING DIVISION

GRINDING DETAIL

STANDARD DETAIL DRAWING 4.08

* THE WEDGE CUT DEPTH SHALL MATCH THE DEPTH OF THE BITUMINOUS OVERLAY