

3.02

RESIDENTIAL

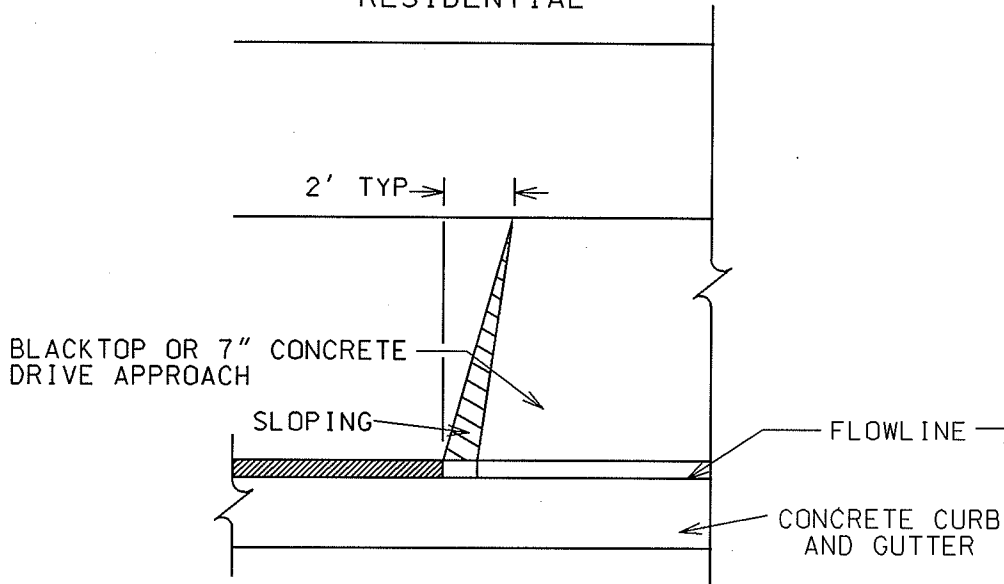

EXPANSION JOINTS IN ACCORDANCE WITH REQUIREMENTS OF 302.2d and 303.2d

COMMERCIAL

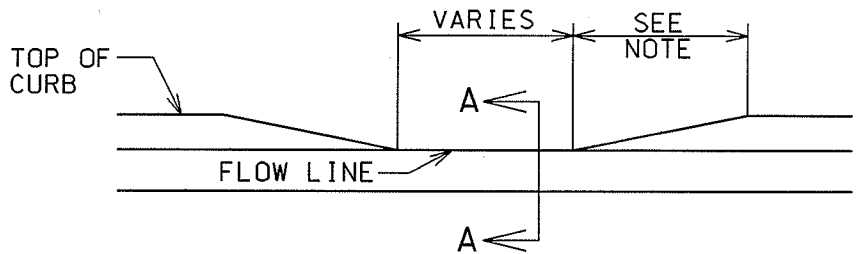
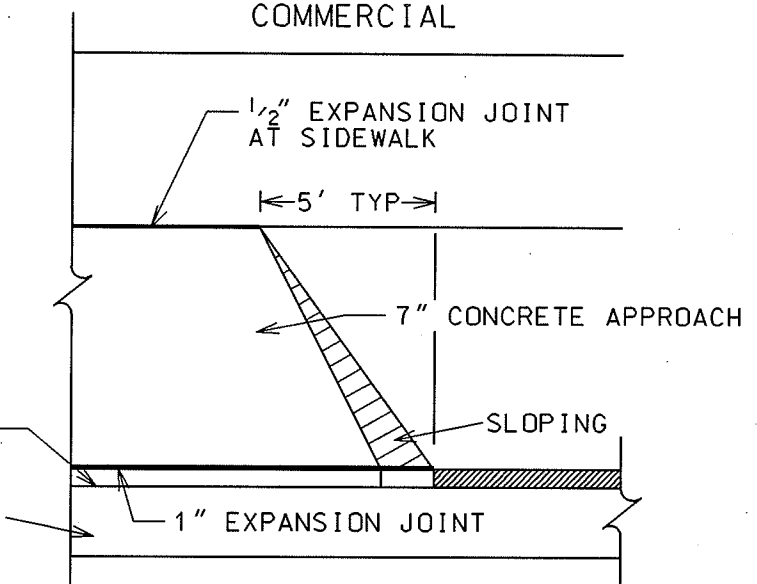

NOTE:
 12" TO 18" TAPER FOR STANDARD DRIVEWAY APPROACH
 18" TO 24" TAPER FOR STANDARD RAMP

TYPICAL CURB CUT TAPER

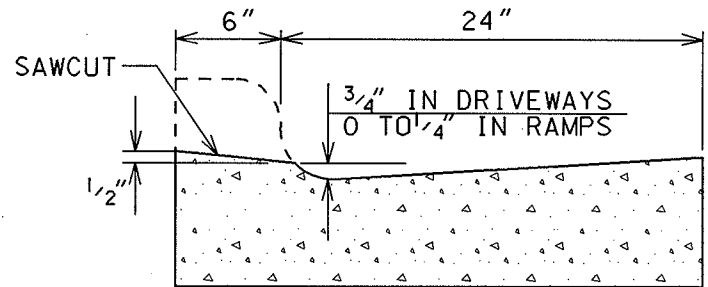

DRIVEWAY SECTION TYPE 'A' CONCRETE CURB & GUTTER

SECTION A-A

GENERAL NOTE:

IF THE CURB CUT IS NOT CONSTRUCTED WITH THE INITIAL CURB AND GUTTER CONSTRUCTION, THE CURB CUT CAN BE MADE BY REMOVING AND REPLACING THE ENTIRE CURB AND GUTTER SECTION OR BY SAWCUTTING THE EXISTING CURB HEAD BY MEANS OF A SPECIAL SAW DESIGNED TO MEET THE DETAILS ABOVE FOR MADISON STANDARD CURB CUTS.

2004

CITY OF MADISON
ENGINEERING DIVISION

MADISON STANDARD
CURB CUT DETAILS

STANDARD DETAIL DRAWING 3.02