

CROWNED PAVEMENT

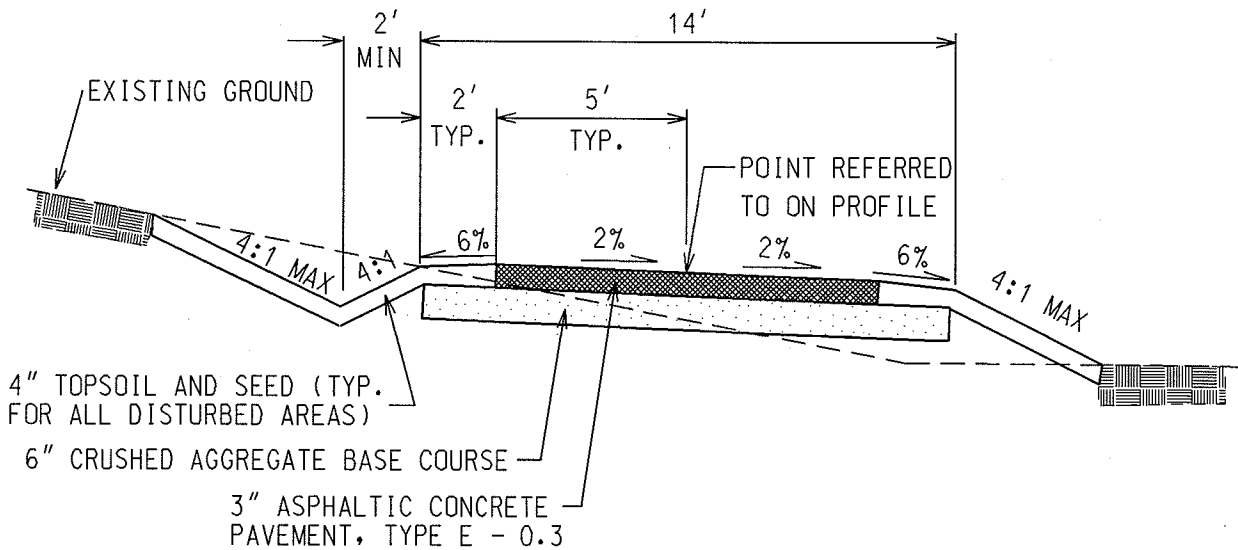

UNIFORM CROSS SLOPE

2004

GENERAL NOTES:

1. GRADING SHALL INCLUDE REMOVING VEGETATION AND TOPSOIL, SHAPING AND COMPACTING THE SUBBASE.
2. SUITABLE FILL AS REQUIRED TO OBTAIN A SUITABLE CROSS SECTION SHALL BE PLACED AND COMPACTED IN 6 INCH MAXIMUM LIFTS.
3. ALL DISTURBED AREAS SHALL BE TOPSOILED AND SEEDDED.

CITY OF MADISON
ENGINEERING DIVISION

TYPICAL SECTION
BIKE PATH

STANDARD DETAIL DRAWING 4.07