

TYPE I

CONCRETE PAVEMENT

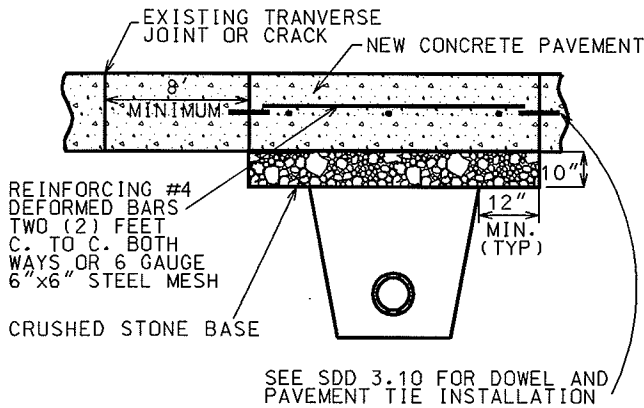

TYPE I UTILITY TRENCH PATCH

THE PAVEMENT SHALL BE REMOVED IN TWO STAGES. THE INITIAL PAVEMENT REMOVAL SHALL BE LIMITED TO THE AREA OF THE PROPOSED TRENCH. FULL-DEPTH SAWCUTTING WILL NOT BE REQUIRED FOR THIS PHASE OF THE PAVEMENT REMOVAL. AFTER THE TRENCH HAS BEEN BACKFILLED AND COMPACTED, AND AFTER THE BASE HAS BEEN RESTORED IN THE AREA OF THE TRENCH, AND AFTER SAWCUTTING THE NEW JOINTS THE FULL DEPTH OF THE EXISTING PAVEMENT (INCIDENTAL), THE REMAINING PAVEMENT TO BE REMOVED SHALL BE REMOVED WITHOUT DISTURBING THE EXISTING BASE.

THE SIZE OF THE PATCH SHALL BE DETERMINED BY THE TOP WIDTH OF THE TRENCH, THE LOCATION AND SKEW OF THE EXISTING TRANSVERSE JOINTS, THE CONDITION OF THE EXISTING PAVEMENT, AND THE CONDITION OF THE BASE. NEW TRANSVERSE JOINTS SHALL BE PARALLEL TO THE EXISTING TRANSVERSE JOINTS, AND SHALL BE A MINIMUM OF ONE (1) FOOT FROM THE TRENCH. THE DISTANCE BETWEEN NEW AND EXISTING TRANSVERSE JOINTS SHALL BE A MINIMUM OF EIGHT (8) FEET, MEASURED PERPENDICULAR TO THE JOINTS. THE PATCH SHALL BE A MINIMUM OF EIGHT (8) FEET IN LENGTH, AND SHALL HAVE THE SAME WIDTH AS THE PAVEMENT LANE.

THE PATCH SHALL BE NINE (9) INCHES IN THICKNESS OF HIGH EARLY STRENGTH CONCRETE, DOWELED AND TIED WITH EPOXY COATED BARS, AND REINFORCED, ALL IN ACCORDANCE WITH THE TYPICAL SECTION.

THE TRANSVERSE EDGES OF THE FINISHED PATCH SHALL BE FLUSH WITH THE EDGES OF THE EXISTING CONCRETE PAVEMENT. THE LONGITUDINAL SURFACE SHALL FORM A STRAIGHT LINE FROM EDGE TO EDGE WITHIN A TOLERANCE OF $\frac{1}{8}$ INCH.

TYPE II

CONCRETE WITH ASPHALTIC OVERLAY

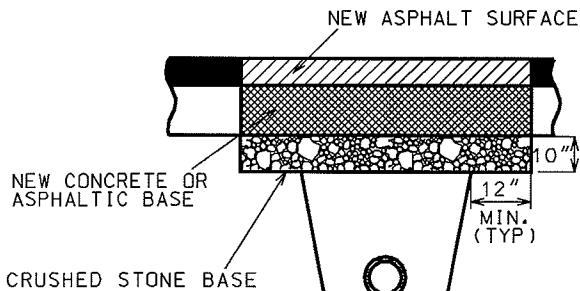

TYPE II UTILITY TRENCH PATCH

THE PATCH SHALL BE 7" HIGH EARLY STRENGTH CONCRETE BASE WITH THE SAME REINFORCEMENT AS THE EXISTING CONCRETE BASE, OVERLAID WITH ASPHALT UPPER LAYER. WHERE SPECIFIED, OR DIRECTED BY THE ENGINEER, THE BASE SHALL BE CONSTRUCTED OF ASPHALTIC BASE COURSE MATERIAL, SHALL BE THE SAME THICKNESS AS THE EXISTING BASE, AND SHALL BE LAID IN TWO OR MORE COMPACTED LIFTS OF NOT MORE THAN 3" IN THICKNESS EACH.

THE PAVEMENT ALONG THE PATCH SHALL BE SAWCUT, FULL DEPTH, AND INCIDENTAL TO THE TRENCH PATCH. THE EDGES OF THE PATCH SHALL BE VERTICAL, FREE OF LOOSE STONES OR CONCRETE PIECES, AND SHALL BE THOROUGHLY WETTED JUST PRIOR TO POURING THE NEW CONCRETE BASE.

THE TOP OF THE NEW CONCRETE OR ASPHALT BASE SHALL BE FLUSH WITH THE TOP OF THE EXISTING CONCRETE BASE.

PRIOR TO PLACING THE ASPHALT UPPER LAYER, THE EDGES OF THE PATCH AND THE SURFACE OF THE NEW CONCRETE BASE SHALL BE THOROUGHLY TACKED WITH LIQUID ASPHALT.

THE ASPHALT UPPER LAYER SHALL BE OF THE SAME THICKNESS AS THE EXISTING ASPHALT OVERLAY WITH A MINIMUM THICKNESS OF 3" AND A MAXIMUM THICKNESS OF 5 $\frac{1}{4}$ " UNLESS OTHERWISE SPECIFIED AND SHALL BE LAID IN ONE OR MORE COURSES AS DIRECTED BY THE ENGINEER. THE ASPHALTIC UPPER LAYER SHALL BE MACHINE LAID WHERE DIRECTED BY THE ENGINEER. WHERE THE ASPHALTIC UPPER LAYER IS MACHINE LAID, AND IS NOT MORE THAN 3" IN THICKNESS, THE ASPHALTIC SURFACE MAY BE LAID IN ONE LIFT.

TYPE III

ASPHALTIC STREET

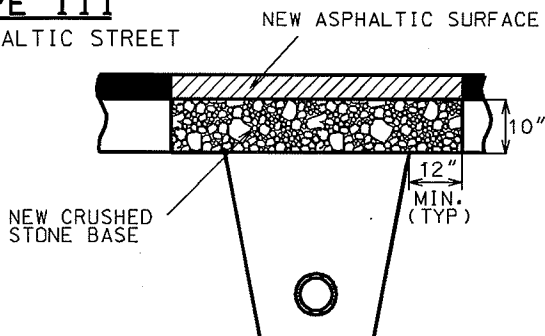

TYPE III UTILITY TRENCH PATCH

THE PATCH SHALL BE CRUSHED STONE BASE COURSE, GRADATION NO. 2 OVERLAID WITH ASPHALT UPPER LAYER EQUAL IN THICKNESS TO THE EXISTING ASPHALTIC PAVEMENT, WITH A MINIMUM THICKNESS OF 3" AND A MAXIMUM THICKNESS OF 5 $\frac{1}{4}$ " UNLESS OTHERWISE SPECIFIED AND LAID IN ONE OR MORE COURSES AS DIRECTED BY THE ENGINEER.

THE PAVEMENT ALONG THE PATCH SHALL BE SAWCUT, FULL DEPTH, AND INCIDENTAL TO THE TRENCH PATCH. THE EDGES OF THE EXISTING ASPHALTIC PAVEMENT SHALL BE FREE OF LOOSE STONES OR PAVEMENT MATERIAL.

THE CRUSHED STONE BASE COURSE SHALL BE INSTALLED IN TWO LIFTS. THE LOWER LIFT SHALL BE THOROUGHLY MECHANICALLY COMPACTED PRIOR TO PLACING THE UPPER LIFT.

THE ASPHALT UPPER LAYER SHALL BE LAID IN TWO LIFTS. THE ASPHALT UPPER LAYER SHALL BE MACHINE LAID WHERE DIRECTED BY THE ENGINEER. WHERE THE ASPHALTIC UPPER LAYER IS MACHINE LAID AND IS NOT MORE THAN 3" IN THICKNESS, THE ASPHALT SURFACE COURSE MAY BE IN ONE LIFT.

PRIOR TO PLACING THE ASPHALT UPPER LAYER, THE EDGES OF THE PATCH AND THE SURFACE OF THE CRUSHED STONE BASE SHALL BE TACKED AND PRIMED WITH LIQUID ASPHALT.

TYPE IV

NEW CRUSHED STONE PAVEMENT

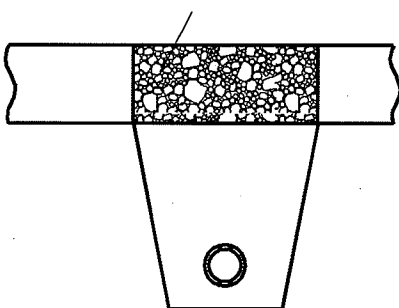

TYPE IV UTILITY TRENCH PATCH

THE PATCH SHALL BE 9" CRUSHED STONE BASE COURSE, GRADATION NO. 2. FULL DEPTH SAWCUTTING OF ADJACENT PAVEMENT (IF ANY) SHALL BE CONSIDERED INCIDENTAL TO THE TRENCH PATCH.

THE CRUSHED STONE BASE COURSE SHALL BE INSTALLED IN THREE LIFTS. EACH LIFT SHALL BE THOROUGHLY MECHANICALLY COMPACTED PRIOR TO PLACING SUCCEEDING LIFTS.

CITY OF MADISON
ENGINEERING DIVISION

TYPICAL PAVEMENT
PATCH SECTIONS