

METHOD A

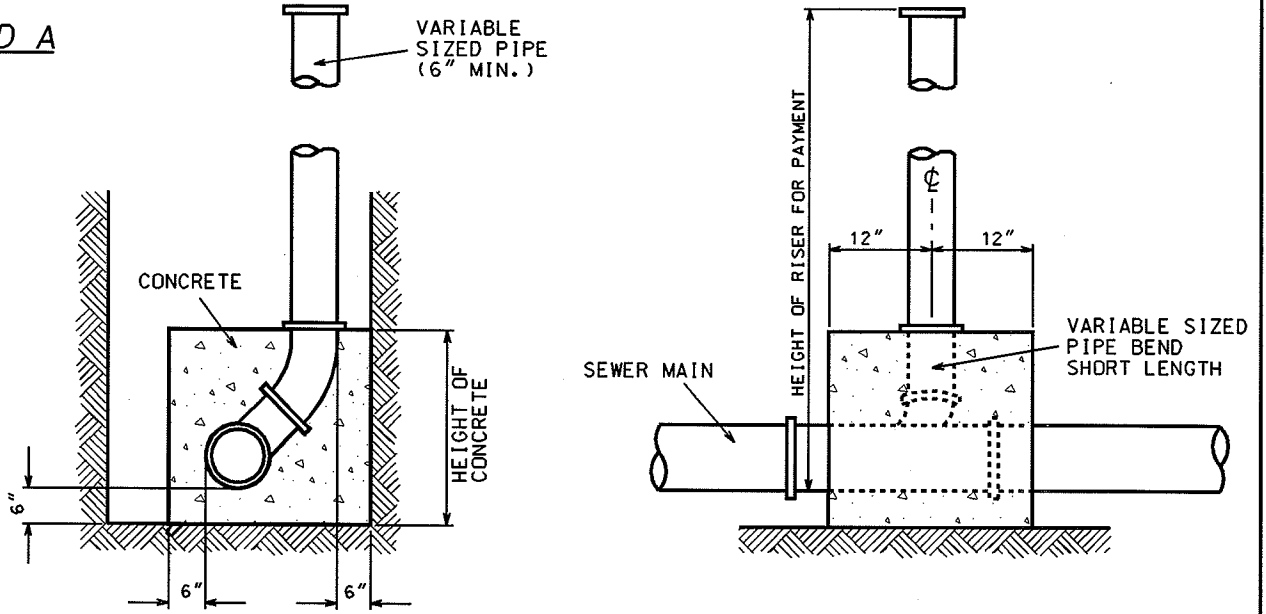

METHOD B

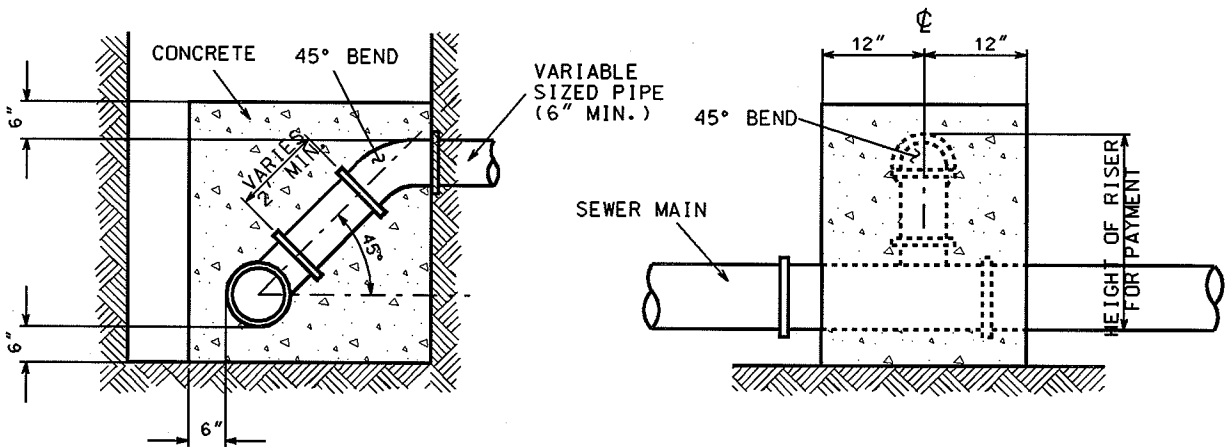

ALTERNATE TO RISER

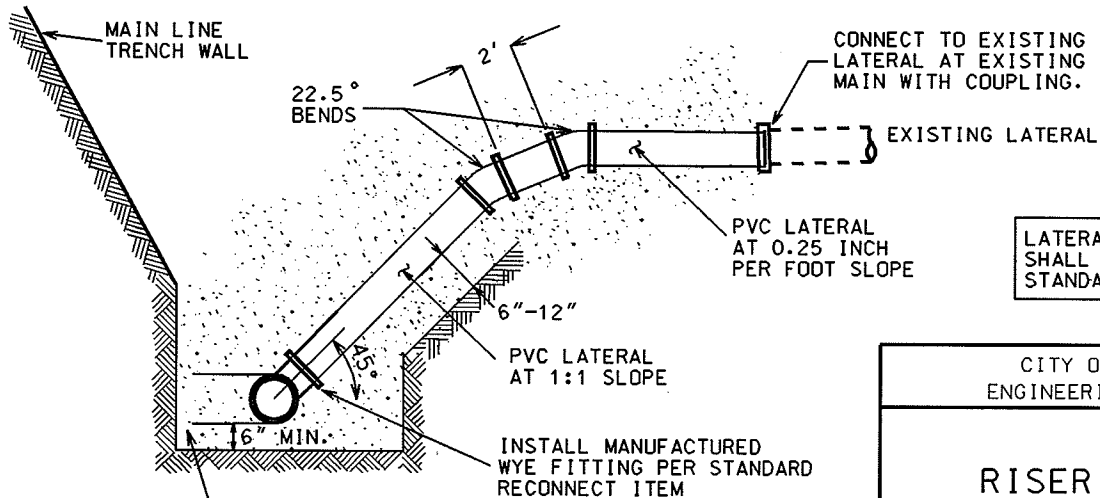

LATERAL AND RECONNECT SHALL CONFORM TO STANDARD SPECIFICATIONS

2004

CITY OF MADISON
ENGINEERING DIVISION

RISER DETAIL

STANDARD DETAIL DRAWING 5.3.1

BEDDING MATERIAL AND DIMENSIONS PER CITY OF MADISON STANDARD SPECIFICATIONS (STANDARD DETAIL DRAWING 5.2.1)