

**TYPE A**

FOR PIPES WITH DIAMETER LESS THAN OR EQUAL TO 27" INNER DIAMETER

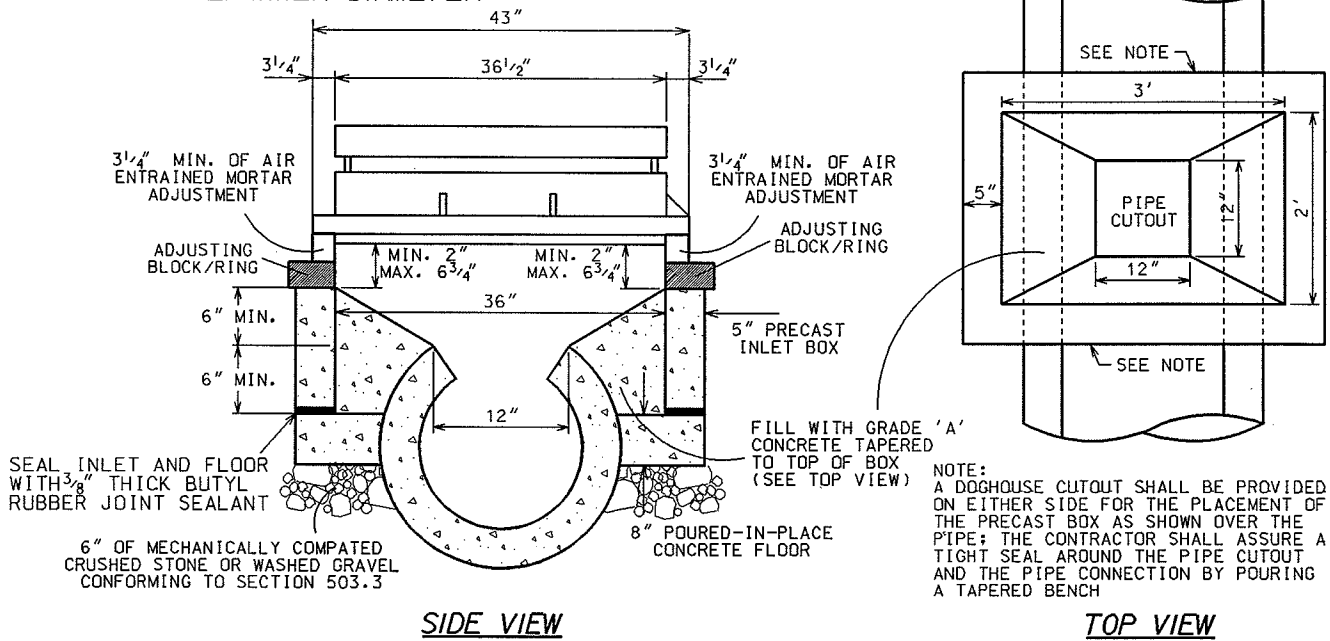

**TYPE B**

FOR PIPES WITH DIAMETER GREATER THAN 27" INNER DIAMETER

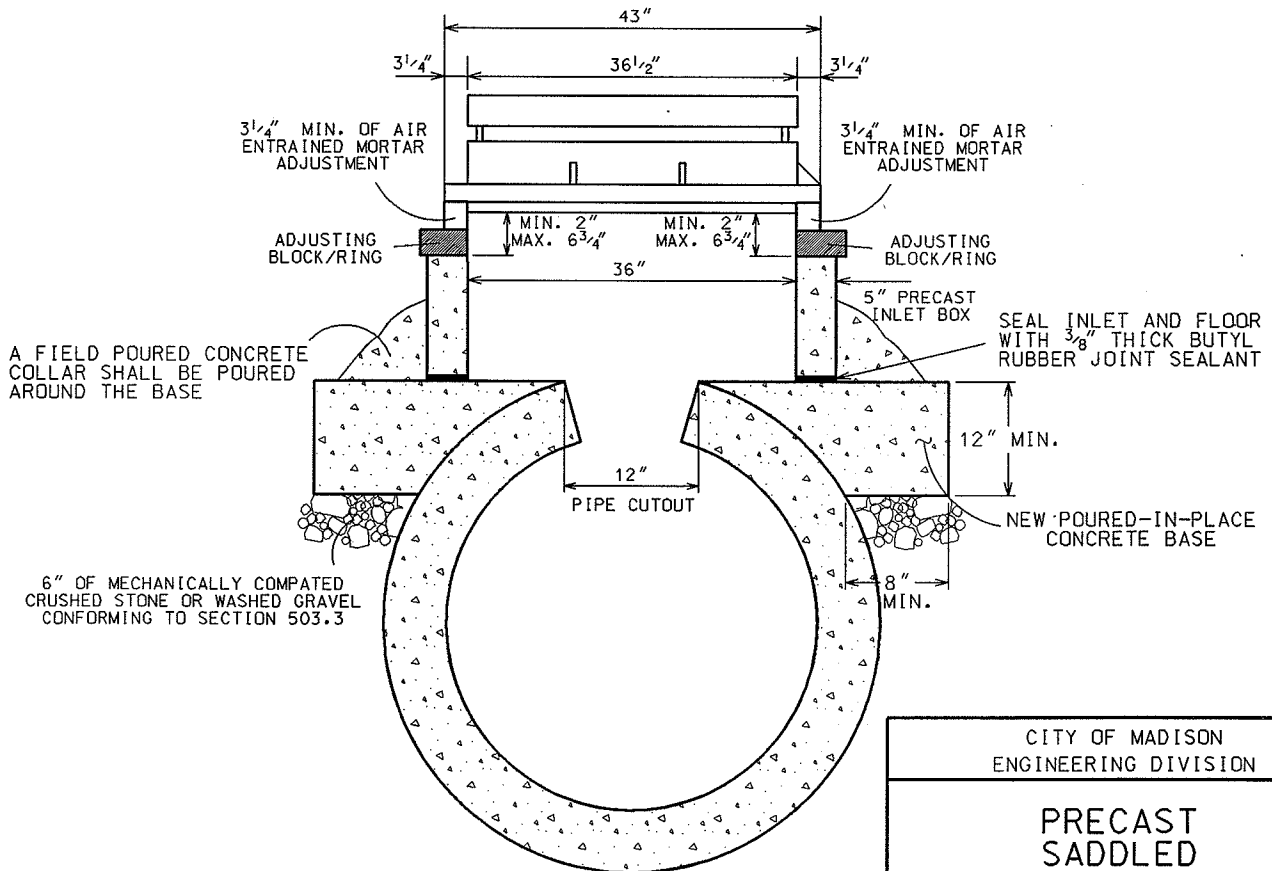

2004

CITY OF MADISON  
ENGINEERING DIVISION

**PRECAST  
SADDLED  
INLET**

DRAWING NOT TO SCALE

STANDARD DETAIL DRAWING 5.7.10