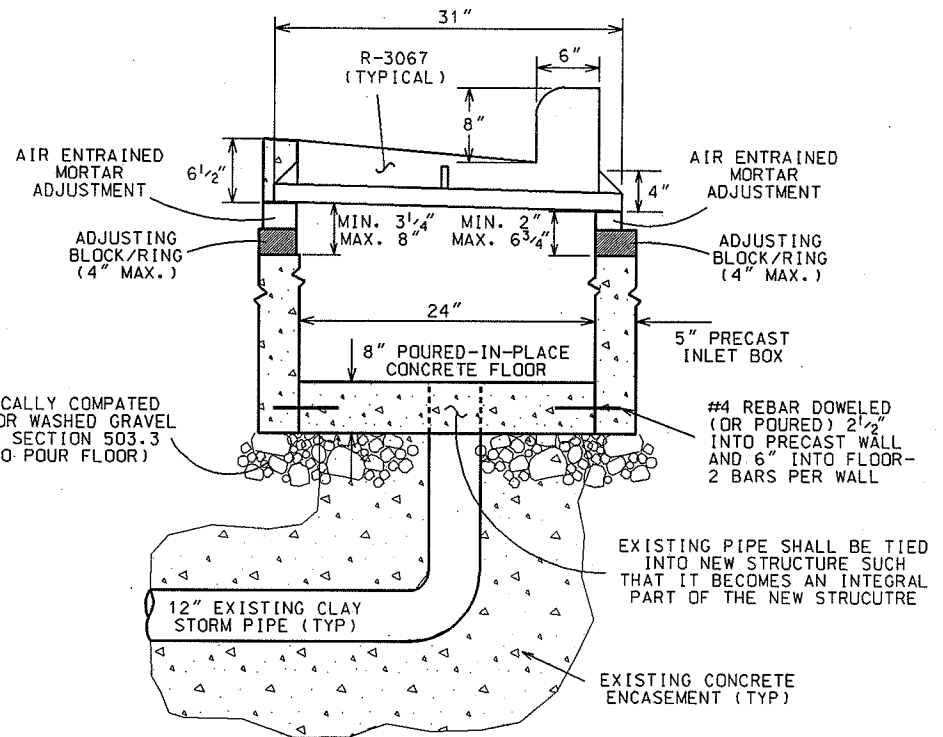
FIELD POUR OPTIONPRECAST OPTION**DESIGN OPTIONS:****(1) FIELD POUR-**

PER THE DESIGN IN THE DETAIL DRAWING, THE MINIMUM DEPTH FOR THE FIELD POUR OPTION SHALL BE 19" (4" WALL + 2" MORTAR ADJUSTMENT + 13" CASTING) WITH AN ADDITIONAL MINIMUM 4" OF EXCAVATION REQUIRED FOR THE FLOOR.

(2) PRECAST

PER THE DESIGN IN THE DETAIL DRAWING, THE MINIMUM DEPTH FOR THE PRECAST OPTION SHALL BE 19" (12" INLET WALL - 8" FLOOR + 2" MORTAR ADJUSTMENT + 13" CASTING) WITH AN ADDITIONAL MINIMUM OF 8" OF EXCAVATION REQUIRED FOR THE FLOOR.

(3) FIELD STACKED

THE DESIGN CONSISTS OF AN 8" FIELD POURED CONCRETE FLOOR, STACKED ADJUSTMENT RINGS, AIR ENTRAINED MORTAR ADJUSTMENT, AND H CASTING.

THE MINIMUM DEPTH FOR THE STACKED OPTION SHALL BE 17" (2" ADJUSTMENT RING, 2" MORTAR ADJUSTMENT, 13" CASTING).

THE MAXIMUM DEPTH SHALL BE 19" (4" ADJUSTMENT RINGS, 2" MORTAR ADJUSTMENT, 13" CASTING)

GENERAL NOTES:

- (1) REMOVE EXISTING INLET AND CLAY PIPE TO A STABLE LOCATION
- (2) REMOVE MATERIAL SURROUNDING PIPE TO A DEPTH OF FOURTEEN (14) INCHES BEYOND THE STABLE LOCATION REFERRED TO ABOVE
- (3) INSTALL NEW INLET CASTING ADJUSTMENTS.
- (4) IF TO FIND A STABLE PIPE LOCATION, THE EXISTING PIPE IS REMOVED BEYOND THE ELBOW, THE RECONSTRUCT TUB INLET SPECIFICATION IS NO LONGER APPLICABLE. THE RELEVANT ITEMS BECOME REMOVE INLET AND REPLACE WITH TYPE 'H' INLET.

DRAWINGS NOT TO SCALE

CITY OF MADISON
ENGINEERING DIVISION

RECONSTRUCT
TUB INLET

STANDARD DETAIL DRAWING 5.7.11