

5.7.18

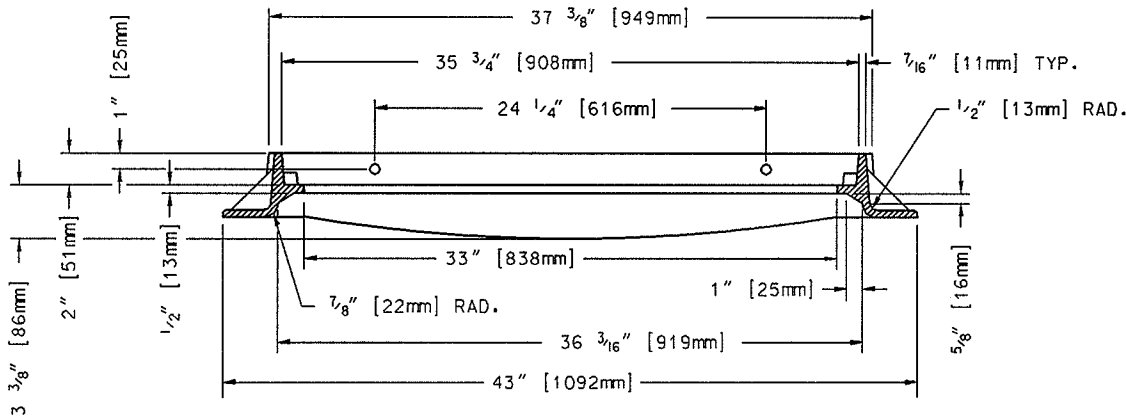
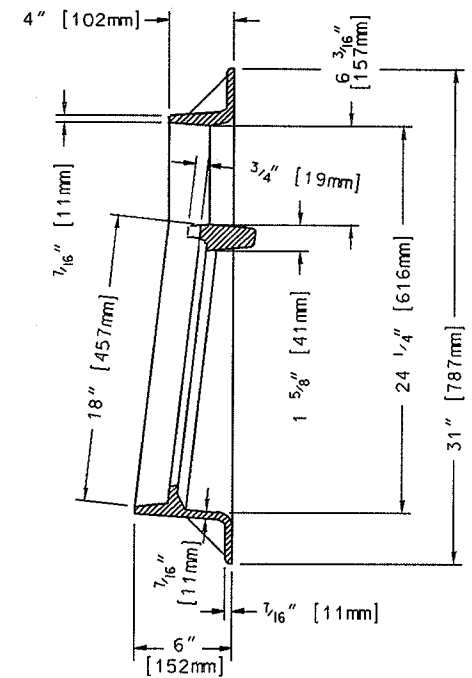
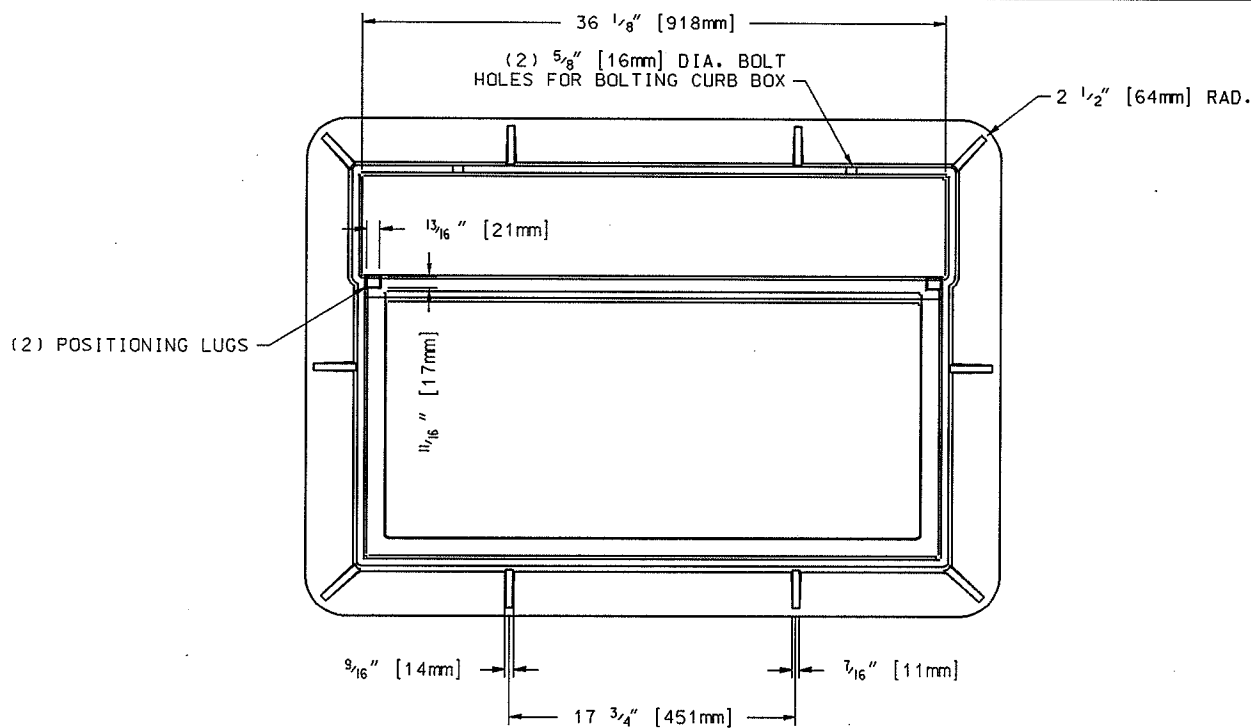

NOTES: ALL DIMENSIONS ARE SHOWN IN ENGLISH AND [METRIC].  
 ALL DRAFT ANGLES ARE 5° UNLESS OTHERWISE SHOWN.  
 MATERIAL: CAST GRAY IRON ASTM A-48, CLASS 35B  
 FINISH: NOT PAINTED  
 WEIGHT: APPROX. 207#

NEENAH FOUNDRY CASTINGS

1. R-3067 CURB INLET FRAME WITH DIAGONAL GRATE (TYPE R) SHALL BE USED FOR TYPE "H" INLETS AT ALL LOW POINTS AND WHERE LONGITUDINAL ROAD SLOPE IS LESS THAN 1%. GRATE PER STANDARD DETAIL DRAWING 5.7.20
2. R-3067-V CURB INLET FRAME WITH VANE GRATE (TYPE V) SHALL BE USED FOR "H" INLETS AT ALL LOCATIONS HAVING A LONGITUDINAL ROAD SLOPE EQUAL TO OR GREATER THAN 1%. GRATE PER STANDARD DETAIL DRAWING 5.7.21

NOTE: ALL DIMENSIONS ARE SHOWN IN ENGLISH AND [METRIC].

GENERAL NOTES:

1. DETAILS OF CONSTRUCTION, MATERIALS, AND WORKMANSHIP NOT SHOWN ON THIS DRAWING SHALL CONFORM TO THE PERTINENT REQUIREMENTS OF THE STANDARD SPECIFICATIONS AND THE APPLICABLE SPECIAL PROVISIONS.
2. DETAIL DRAWINGS FOR PROPOSED ALTERNATE DESIGNS FOR INLET COVERS SHALL BE SUBMITTED TO THE ENGINEER FOR APPROVAL PROVIDING THAT SUCH ALTERNATE DESIGNS MAKE PROVISION FOR EQUIVALENT CAPACITY AND STRENGTH.
3. ROUND FRAMES AND COVERS SHALL HAVE CONTINUOUSLY MACHINED BALL BEARING SURFACES TO PREVENT ROCKING AND RATTLING.
4. ACTUAL WEIGHT OF COVERS MAY VARY WITHIN 5 PERCENT (PLUS OR MINUS) OF THE APPROXIMATE WEIGHT.
5. INLETS SHALL BE DEPRESSED IN THE CURB FLOW LINE, SEE MADISON STANDARD DETAIL DRAWING 5.7.7

2004

CITY OF MADISON ENGINEERING DIVISION
<b>R-3067 FRAME</b>
STANDARD DETAIL DRAWING 5.7.18