

ALLEY GUTTER DETAIL

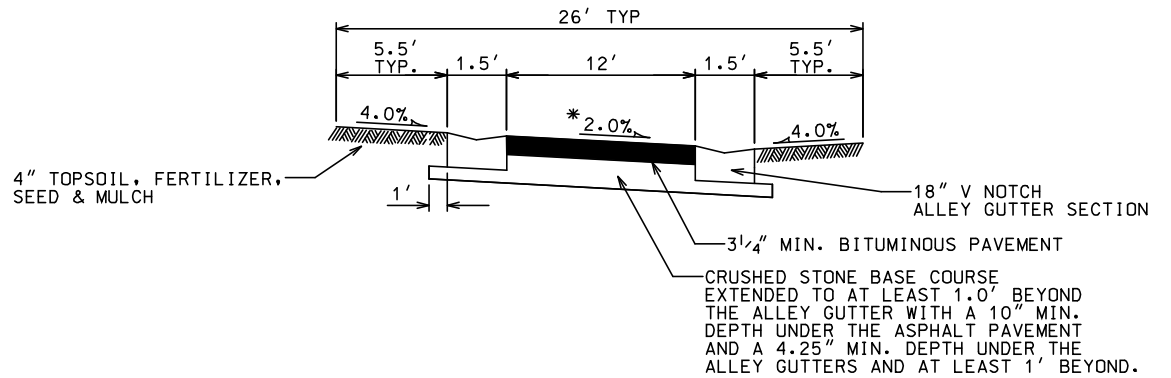

TYPICAL ALLEY SECTION

NOTES:

EDGE OF PAVEMENT RADII SHALL NOT BE LESS THAN 25 FEET

* SEE ARROWS ON PLAN PAVEMENT FOR DIRECTION OF CROSS SLOPE.

CURBS SHALL HAVE A MINIMUM 0.5% LONGITUDINAL GRADE TOWARD INLETS.

ALL STORM WATER SHALL BE COLLECTED BY STORM SEWER INLETS PRIOR TO FLOWING OVER PRIVATE PROPERTY OR SIDEWALKS.

THE EDGE OF ALLEY PAVEMENT SHALL NOT BE CLOSER THAN 7.0' TO THE PROPERTY LINE AT ANY POINT.

2007

CITY OF MADISON
ENGINEERING DIVISION

TYPICAL ALLEY WITH
CURB & GUTTER

STANDARD DETAIL DRAWING 4.07

4.07