

**CITY OF MADISON**

**Standard Specifications**

**for**

**Public Works Construction**

**2014 Edition**



**CITY OF MADISON**

**Standard Specifications for Public Works Construction**

**2014 Edition**

- Part I: General Conditions
- Part II: Earthwork and Miscellaneous Construction
- Part III: Concrete and Concrete Structures
- Part IV: Pavements
- Part V: Sewers and Sewer Structures
- Part VI: Traffic Engineering Electrical & Pavement Markings
- Part VII: Water Mains and Service Laterals
- Part VIII: Standard Detail Drawings
- Part IX: Standard Bid Item Numbers

## Part I - General Conditions

ARTICLE 101 - DEFINITION AND TERMS.....	1
ARTICLE 102 - BIDDING REQUIREMENTS AND CONDITIONS.....	5
102.1    Prequalification of Bidders. ....	5
102.2    Disqualification of Bidders. ....	5
102.3    No Other Interested Parties. ....	6
102.4    Proposals. ....	6
102.5    Bid Deposit. ....	7
102.6    Rejection of Proposals. ....	7
102.7    Withdrawal of Proposals. ....	7
102.8    Examination of Plans, Specifications, Special Provisions and Site of Work.....	7
102.9    Bidder's Understanding. ....	8
102.10   Prevailing Wage. ....	8
102.11   Affirmative Action. ....	9
102.12   Best Value Contracting. ....	9
102.13   Equal Benefits Requirement (Sec. 39.07, MGO).....	10
ARTICLE 103 - AWARD AND EXECUTION OF THE CONTRACT .....	12
103.1    Consideration of Proposals. ....	12
103.2    Award of Contract.....	12
103.3    Execution of Contract and Bond.....	12
103.4    Failure to Execute Contract.....	12
103.5    Payment and Performance Bond.....	12
ARTICLE 104 - SCOPE OF WORK.....	13
104.1    Lands for Work. ....	13
104.2    Intent and Coordination of Contract Documents. ....	13
104.3    Changes in the Work.....	13
104.4    Increased or Decreased Quantities.....	14
104.5    Increased Items. ....	14
104.6    Decreased and Deleted Items.....	14
104.7    Extra Work.....	14
104.8    Removals.....	17
104.9    Old Material. ....	17
104.10   Cleaning Up. ....	17
104.11   Final Clean Up. ....	18
ARTICLE 105 - CONTROL OF THE WORK .....	19
105.1    Authority of the Engineer. ....	19
105.2    Review of Engineer's Decision.....	19
105.3    Authority and Duties of Inspector.....	19
105.4    Participation by Another Governmental Body.....	20
105.5    Inspection of Work. ....	20
105.6    Contractor's Responsibility for Work.....	21
105.7    Contract Documents.....	21
105.8    Working Drawings. ....	22
105.9    Surveys, Points and Instructions. ....	22

105.10	Conformity with Plans and Specifications.....	22
105.11	Removal of Unauthorized and Unacceptable Work. ....	23
105.12	Cooperation by Contractor.....	23
105.13	Order of Completion.....	25
105.14	Use of Completed Portions.....	25
105.15	Substantial Completion.....	25
105.16	Guarantee.....	25
ARTICLE 106 - CONTROL OF MATERIALS.....		26
106.1	Source of Supply and Quality.....	26
106.2	Plant Inspection.....	26
106.3	Samples and Tests.....	27
106.4	Storage of Materials.....	28
106.5	Defective Materials.....	28
ARTICLE 107 - PROTECTION OF PUBLIC AND UTILITY INTERESTS.....		29
107.1	Public Convenience and Safety.....	29
107.2	Protection and Restoration of Property and Property Monuments.....	31
107.3	Indemnification.....	32
107.4	Contractor's Liability Insurance.....	33
107.5	Use of Explosives.....	35
107.6	Dustproofing.....	35
107.7	Maintenance of Traffic.....	36
107.8	Notification When Closing Street.....	37
107.9	Barricades, Warning Signs and Flagging.....	37
107.10	Opening of Section of Highway to Traffic.....	41
107.11	Use of City Water.....	41
107.12	Railroad-Highway Grade Separations and Approaches, New Railroad Crossings, Operations on Railroad Right-of-Way.....	41
107.13	Tree Protection Specifications.....	44
107.14	Weapons Prohibition.....	51
ARTICLE 108 - LEGAL RELATIONS.....		52
108.1	Laws to be Observed.....	52
108.2	Permits and Licensing.....	52
108.3	Patented Devices, Materials and Processes.....	52
108.4	Safety, Health and Sanitation.....	52
108.5	Personal Liability of Public Officials.....	53
108.6	No Waiver of Legal Rights.....	53
ARTICLE 109 - PROSECUTION AND PROGRESS.....		54
109.1	Subletting or Assignment of Contract.....	54
109.2	Prosecution of the Work.....	54
109.3	Limitations of Operations.....	55
109.4	Character of Workers.....	55
109.5	Methods and Equipment.....	55
109.6	Suspension of the Work.....	56
109.7	Time of Completion.....	57
109.8	Delays and Extensions of Time.....	58
109.9	Liquidated Damages.....	58

109.10	Default on Contract.....	59
109.11	Removal of Equipment. ....	60
109.12	Contractor’s Right to Stop Work or Terminate Contract.....	60
109.13	Emergency Deferment or Cancellation of Contract.....	61
109.14	Mobilization.....	61
ARTICLE 110 - MEASUREMENT AND PAYMENT .....		63
110.1	Measurement of Quantities. ....	63
110.2	Partial Payments.....	64
110.3	Setoffs. ....	65
110.4	Unpaid Wages.....	65
110.5	Acceptance and Final Payment.....	65
110.6	Payment Withheld.....	66
110.7	Differing Site Conditions.....	66
110.8	Claims for Adjustment in Compensation.....	66

## **ARTICLE 101 - DEFINITION AND TERMS**

---

When the contract documents include an abbreviation from the following list, it shall mean:

AAN.....	American Association of Nurserymen
AAR.....	Association of American Railroads
AASHTO.....	American Association of State Highway and Transportation Officials
AISI.....	American Iron and Steel Institute
AREA.....	American Railway Engineering Association
USASI.....	United States of America Standards Institute
ASTM.....	American Society for Testing and Materials
AWS.....	American Welding Society
AWWA.....	American Waterworks Association
ASA.....	American Standards Association
ANSI.....	American National Standards Institute
ASME.....	American Society of Mechanical Engineers
FHWA.....	Federal Highway Administration
SAE.....	Society of Automotive Engineers

**Addendum to the Contract.** An amendment to the contract documents modifying the obligations of the parties thereunder, including, but not limited to, the performance of the work, the furnishing of labor and materials, and the basis of payment.

**Addendum to the Standard Specifications.** Specifications adopted subsequent to the publication of these Specifications, which modify, supplement or otherwise depart from these Specifications.

**Advertisement for Bids.** The advertisement for proposals for all work or materials on which bids are required. Such advertisement will indicate with reasonable accuracy the quantity and location of the work to be done, or the character and quantity of the material to be furnished, and the time and place of submitting the proposals.

**Agreement.** The written agreement between the City and the Contractor setting forth the obligation of the parties thereunder, including, but not limited to; the performance of the work, the furnishing of labor and materials, the basis of payment, and contract time. Other contract documents are incorporated into the agreement.

**Award.** The acceptance of a bid by the formal approval of the Common Council.

**Bid Deposit.** The security furnished with a bid to guarantee that the bidder will enter into the contract if its bid is accepted.

**Bidder.** Any individual, partnership, limited liability company or corporation submitting a proposal for the work contemplated, acting directly or through a duly authorized representative.

**Board of Public Works.** The Board of Public Works of the City.

**Calendar Day.** Every day shown on the calendar, Sundays and holidays included.

**Certificate of Compliance.** A certification, provided by a manufacturer, producer, or supplier of a product, that the product as furnished to the Contractor complies with the pertinent Specifications or contract requirements.

**Certified Report of Test or Analysis.** A test report, provided by a laboratory, or by a product manufacturer, producer or supplier, indicating actual results of tests or analyses, covering elements of the specification requirements and validated by certification.

**City.** The City of Madison, Wisconsin.

**Contract Documents.** The contract documents include the proposal, bid deposit, agreement, payment and performance bond, Specifications, Supplemental Specifications, special provisions, general and detailed plans specifically identified in the agreement, notice to proceed, contract change orders and agreements that are required to complete the construction of the work in an acceptable manner, including authorized extensions thereof.

**Contract Change Order.** A written order, authorization or agreement executed by the Contractor and the City covering work not otherwise provided for, revisions in or amendments to the contract, or conditions specifically prescribed in the Specifications as requiring contract change orders. Such document becomes a part of the contract when executed by the contracting parties.

**Contract Time.** The number of days or the date stated in the agreement for the completion of the work.

**Contractor.** The individual, partnership, limited liability company, joint venture, corporation or agency undertaking the execution of the work under the terms of the contract and acting directly or through a duly authorized representative.

**Detour.** A road designated as a temporary route to carry vehicular traffic around a section of a street or highway which is closed to through traffic.

**Drip Line.** An imaginary circle that could be drawn on the soil around a tree directly under the tips of its outermost branches.

**Engineer.** The City Engineer of the City of Madison acting personally or through a duly authorized representative.

**Equipment.** All machinery, equipment, tools, and apparatus, together with necessary supplies for upkeep, operation and maintenance, necessary for the proper construction and acceptable completion of the work.

**Highway, Street, or Road.** A general term denoting a public way for the purpose of vehicular travel, including the entire area within the right-of-way.

**Inspector.** A representative of the Engineer assigned and authorized to make detailed inspection of any or all portions of the work or materials therefor.

**Materials.** Any substances specified for use in the construction of the project and its appurtenances.

**Notice of Award.** A written notice by the City to the apparent successful bidder stating that upon compliance by that bidder with the conditions precedent stated therein, within the time specified, the City will sign and deliver the agreement.

**Notice to Proceed.** A written notice to the Contractor of the time within which the Contractor shall begin the prosecution of the work.

**NRC.** An abbreviation for no root cutting that will be marked on the sidewalk, driveway, or curb that is being repaired or removed. No root cutting shall occur until reviewed by City Forester.

**Payment and Performance Bond.** The approved form of security, executed by the Contractor and the Contractor's surety or sureties, guaranteeing the faithful performance of the contract and the payment of claims for work or labor performed and materials furnished for or about the work under the contract, pursuant to the requirements of Section 779.14, Wis. Statutes.

**Plans.** The approved plans, profiles, typical cross sections, and other drawings identified in the contract documents, which show the location, character, dimensions, and details of the work to be done.

**Project.** The specific construction to be performed under the contract.

**Project Area.** The location of the construction to be performed under the contract.

**Proposal.** The offer of the bidder, submitted on the prescribed proposal form, to perform the work including the furnishing of labor and materials at the prices quoted by the bidder.

**Proposal Form.** The approved form on which the City requires formal bids to be prepared and submitted for the work.

**Root Flare.** A swelling where tree roots join the trunk and are visible at the soil surface.

**Shop Drawings.** All drawings, diagrams, and illustrations, such as stress sheets, erection plans, falsework plans, framework plans, cofferdam plans, bending diagrams for reinforcing steel, or similar data prepared by the Contractor, or by a subcontractor, manufacturer, fabricator, or supplier, which the Contractor is required to submit to the Engineer for approval.

**Sidewalk.** The portion of the street primarily constructed for the use of pedestrians.

**Special Provisions.** Special directions, provisions, or requirements peculiar to the project under consideration and not otherwise detailed or set forth in these Specifications.

**Specifications.** The directions, provisions, and requirements contained herein, together with written agreements and documents incorporated in the contract documents, pertaining to the method or manner of performing the work, the quantities, and the quality of materials to be furnished under the contract.

**Standard Specifications.** The body of directions, provisions, and requirements contained herein, together with all supplements and addenda thereto.



**Street Tree.** A tree located within a terrace (between the curb and sidewalk) or on public right of way.

**Subcontractor.** Any individual, partnership, limited liability company, joint venture, or corporation to whom the Contractor sublets any part of the contract.

**Supplemental Specifications.** Specifications adopted subsequent to the publication of these Specifications.

**Surety.** The corporate body bound with and for the Contractor to ensure performance of the contract and payment of all obligations pertaining to the work.

**Traffic Engineer.** The Traffic Engineer of the City of Madison acting personally or through a duly authorized representative.

**Work.** Work shall be understood to mean the furnishing of all labor, materials, equipment, and other incidentals necessary or convenient to the successful completion of the project, or a particular part of the project, in accordance with the requirements of the contract.

**Work Day.** A work day shall be any day that a Contractor can work on a project and which would or does necessitate an inspector on the project for any part of the day. If inclement weather curtails construction, the Engineer shall decide what portion, if any part of a day, shall be called a "Work Day." Work days may be counted to the nearest one-half day. A record of work days shall be kept on the job by the inspector.

## **ARTICLE 102 - BIDDING REQUIREMENTS AND CONDITIONS**

---

### **102.1 Prequalification of Bidders.**

All bidders shall file with the Engineer, during regular working hours, not less than seven (7) days prior to the day set for opening bids, proof of responsibility on forms furnished by the City.

The Engineer shall, determine if the bidder is qualified for the type of work for which the bidder requests prequalification. The decision of the Engineer shall be final and conclusive, unless within fifteen (15) days after such decision the bidder applies in writing to the City Engineer requesting that an appeal be considered by the Board of Public Works.

The Engineer may require a special prequalification for particular projects and/or may require additional information regarding a prequalified bidder's prequalifications to do certain aspects of the work.

In accordance with Section 39.02 of the Madison General Ordinances, all bidders shall submit in writing to the Affirmative Action Division of the City of Madison, a Certificate of Compliance or an Affirmative Action Plan at the same time or prior to the submission of the proof of responsibility forms.

### **102.2 Disqualification of Bidders.**

Notwithstanding a prior finding of responsibility, any one or more of the following causes may be considered as sufficient for rejection of the bidder as nonresponsible for a given contract.

1. Developments subsequent to establishment of bidder's competency and qualifications which, in the opinion of the Board of Public Works would reasonably be construed as affecting the ability of the bidder to perform the work.
2. Conviction of a violation of a State or Federal law or regulation, or rule or regulation of a Federal department, board or bureau, or of a State department, board, or commission, relating to or reflecting on the competency of the bidder for performing construction work.
3. More than one proposal for the same work from an individual, partnership, limited liability company or corporation under the same or different names.
4. Evidence of collusion among bidders.
5. Lack of responsibility as shown by the quality or timeliness of past work for the City.
6. Noncompliance with terms of previous or existing contracts.
7. Uncompleted work which, in the judgment of the Board of Public Works, might hinder or prevent the prompt completion of additional work if awarded.
8. Uncompleted work on which the actual time used has exceeded the contract time set therefor, or on which work the performance or progress is not satisfactory in the judgment of the Board of Public Works.

Part I - General Conditions

9. Failure or refusal to submit a Certificate of Compliance or Affirmative Action Plan as defined by Section 39.02 of the Madison General Ordinances (entitled Affirmative Action) and as required by Section 102.11 of these Specifications.
10. Failure to comply with the Section 33.07 of the Madison General Ordinances (entitled Best Value Contracting).

**102.3 No Other Interested Parties.**

The bidder declares that the only persons interested in this contract as principals are therein named as such; that no official of the City and no person acting for or employed by the City is directly or indirectly interested in this bid, or in any contract which may be made under it, or in any expected profit to arise therefrom; that this bid and this contract are made in good faith, without fraud, collusion or connection with any other persons bidding for the same work.

**102.4 Proposals.**

No bid will be accepted that does not contain an adequate or reasonable price for each and every item named in the Schedule of Unit Prices.

A lump sum bid for the work in accordance with the plans and Specifications is required. The lump sum bid must be the same as the total amounts bid for the various items and it shall be inserted in the space provided.

Unit price figures shall be written numbers in the spaces provided.

In case of conflict between a unit price bid and the corresponding extended amount, or in the absence of an extended amount, the unit price bid shall govern.

All numbers, words, and signatures in the proposal shall be written with ink.

All papers bound with or attached to the proposal form are considered a part thereof and must not be detached or altered when the proposal is submitted. The plans, Specifications and other documents designated in the proposal form will be considered a part of the proposal whether attached or not.

A proposal submitted by an individual shall be signed by the bidder or by a duly authorized agent. A proposal submitted by a partnership shall be signed by a partner. A proposal submitted by a limited liability company shall be signed by an authorized member. A proposal submitted by a corporation shall be signed by an authorized officer or duly authorized agent of such corporation, and the proposal shall show the name of the State under the laws of which such corporation was chartered. The required signatures shall in all cases appear in the space provided therefor on the proposal.

The bidder shall submit the proposal on the form furnished by the City.

Each proposal shall be placed, together with the Bid Deposit, in a sealed envelope, so marked as to indicate name of project, the contract number or option to which it applies, and the name and address of the Contractor. Proposals will be received at the place and until the hour and date designated in the advertisement. When sent by mail, the sealed proposal marked as indicated above shall be enclosed in an additional envelope. Proposals sent by mail, submitted in person or otherwise delivered must be

in the hands of the official conducting the letting by the hour and date designated in the advertisement. Proposals received after the time designated will be returned to the bidder unopened.

### **102.5 Bid Deposit.**

No proposal shall be considered unless either (i) it is accompanied by a Bid Deposit of the character and amount described in the Advertisement for Bids or (ii) a Biennial bid bond in an amount and form acceptable to the City of Madison has been previously submitted.

Bid Deposits of unsuccessful bidders shall be returned following the award of the contract by the Common Council. Bid Deposit of the successful bidder shall be returned within forty-eight (48) hours following execution of the contract and bond as required.

### **102.6 Rejection of Proposals.**

Proposals may be rejected if they show any alterations of form, additions or amendments not called for, conditional or alternate bids unless called for, incomplete bids, erasures, or irregularities of any kind. Proposals in which the unit prices for some items are out of proportion to the prices for other items, or proposals in which unit prices are not submitted for each item of work listed may be rejected.

The Board of Public Works reserves the right to reject any and all bids and to reject the bid of any person or firm who, in its opinion, has not had sufficient experience in the type of construction on which they are bidding, or who is not provided with the necessary capital, materials, machinery and supervisory personnel to execute the work to be contracted for to the satisfaction of the said Board.

The City reserves the right to waive minor irregularities, and to proceed to do the work otherwise, if in the judgment of the Board of Public Works the best interest of the City will be served thereby.

### **102.7 Withdrawal of Proposals.**

All proposals filed with the City will be kept secure and unopened and will not be allowed to pass out of the custody of a representative of the City, except on written request of the bidder or the bidder's authorized representative made prior to expiration of the time set for receipt of proposals, and if such withdrawal is made, such prospective bidder shall not be entitled to bid on the contract at hand unless the same is readvertised and proposals are again requested upon such advertisement.

### **102.8 Examination of Plans, Specifications, Special Provisions and Site of Work.**

The bidder is required to examine carefully the work site, the proposal form, plans, Specifications, Supplemental Specifications, special provisions and contract forms for the work contemplated. It will be assumed that the bidder has investigated and is satisfied as to the conditions to be encountered for performing the work as scheduled, and as to the character, quality and quantities of work to be performed and materials to be furnished, and as to the requirements of the plans, Specifications, Supplemental Specifications, special provisions and contract. The submission of a proposal shall be considered conclusive evidence that the bidder has made such examination and is satisfied as to all the conditions and contingencies.

## **102.9 Bidder's Understanding.**

It is understood and agreed that the bidder, by careful examination, satisfy himself as to the nature and location of the work, the conformation of the ground, the character, quality and quantity of the materials to be encountered, the character of equipment and facilities needed preliminary to and during prosecution of the work, the general and local conditions, and all other matters which can in any way affect the work under this contract.

Bidders must satisfy themselves by such reasonable means as they may prefer as to the accuracy of the Engineer's estimates of quantities, and soil conditions, or otherwise, and shall not at any time after submission of a bid dispute such estimate of the Engineer, nor assert that there was any misunderstanding in regard to the nature or amount of the work to be done.

The City has endeavored to determine the location of existing utilities in the area of the work and so indicate on the appropriate drawings. The City makes no warranty as to the accuracy or completeness of such representations. It is understood and agreed that the cost of performing work in the vicinity of existing utilities indicated or reasonably inferable is included in the bid price.

No employee, agent or consultant of the City is authorized to make any representations as to the materials or workmanship involved, or the conditions to be encountered, and the Contractor agrees that no such statement or the evidence of any document or plan, not a part of this contract, shall constitute any grounds for claim as to conditions encountered. No verbal agreement or conversation with any employee, agent or consultant of the City, either before or after the execution of this contract, shall affect or modify any of the terms or obligations herein contained.

## **102.10 Prevailing Wage.**

### **102.10(a) Prevailing Wage Rate**

All bidders are notified that if prevailing wage rates are required, as specified in Special Provision Section 102.10, all laborers performing work on the Contract must be paid in accordance with the Prevailing Wage Rate Determination included in the Contract Documents.

For the information of the employees working on the project, a copy of the wage scale included in the contract documents and the provisions of Section 66.0903(8) of the Wisconsin Statutes shall be kept posted by the employer and in at least one conspicuous and easily accessible place at the site of the project.

The Contractor shall ensure that employees shall be paid unconditionally and shall receive the full amounts accrued at the time of payment, computed at rates not less than those stated in the Prevailing Wage Rate Determination and that each employee's rate shall be determined by the work that is done within the trade or occupation classification which should be properly assigned to such employee. Questions regarding an employee's classification or rate of pay within that classification, shall be resolved by the practice that predominates in the industry and on which the trade or occupation rate/classification is based. Therefore, rate of pay, classification and work jurisdiction disputes shall be resolved by relying upon practices established by collective bargaining agreements and guidelines used in such determinations by appropriate recognized trade unions operating within the City of Madison.

The Contractor shall agree that the normal rate of wage paid to the Contractor's employees on other projects shall not be reduced or otherwise diminished as a result of the requirement to pay no less than the minimum rate of wage scale on a City project. Mulcting of employees on City projects by contractors, such as by kickbacks or other such devices, is prohibited.

These contract provisions shall apply to all work performed on the contract by the Contractor with its own organization and with assistance of laborers under its immediate superintendency and to all work performed by piecework or by subcontract. No laborer, worker, or mechanic shall be employed directly upon the site of the work except on a wage basis, but this shall not be construed to prohibit the rental of equipment from individuals.

#### **102.10(b) Records**

The Contractor shall keep weekly payroll records setting forth the name, address, telephone number, classification, wage rate and fringe benefit package of each employee who worked on such City project, and the Contractor must keep records of the individual time each employee worked on the project and for each day of the project. Records shall include employee demographics or contractor can submit a one-time report of all employee demographics that can be matched up with weekly payrolls. Such records shall also set forth the total number of hours of overtime credited to each such employee for each day and week and the amount of overtime pay received in that week. Such records shall, in addition, set forth the full weekly wages earned by each such employee and the actual hourly wage paid to that employee. The Contractor shall submit payroll records to the Engineer every week for those periods when work is being done on the project. Said submittal shall be within twenty-one (21) calendar days of the end of the Contractor's weekly pay period.

In the event of a refusal by the Contractor to submit payroll records as required by the contract, the City of Madison shall have the option to cancel this contract and request the Surety to perform or to relet the balance of the work for bids, and in that event, to charge the Contractor for any loss which the City may incur thereby.

#### **102.11 Affirmative Action.**

The Contractor shall comply with the applicable requirements of Section 39.02 of the Madison General Ordinances entitled "Affirmative Action Ordinance". Compliance requires completion and execution of the document entitled "The City of Madison Affirmative Action Plan for Public Works Contractors".

#### **102.12 Best Value Contracting.**

The Contractor and all Subcontractors shall comply with Madison General Ordinance (MGO) section 33.07(7). The Contractor and all Subcontractors shall participate in a Class A Apprenticeship Program for each separate trade or classification in which it employs craft employees and shall continue to participate in such program or programs for the duration of the project. The Contractor or Subcontractor shall not be required to have an apprentice on this project in order to be in compliance with MGO 33.07(7).

The Contractor shall complete pages **F-2 and F-3** entitled, "Best Value Contracting."

This Contract shall be considered a Best Value Contract if the Contractor's bid is equal to or greater than the amount set in the contract specifications for a single trade contract; or equal to or greater than the amount set in the contract specifications for a multi-trade contract.

In addition, this contract shall be exempt from Best Value Contracting requirements if the Contractor provides information prior to the award of contract sufficient such that the City Engineer makes a finding that the contracted work is not considered apprenticeable.

Each Contractor or Subcontractor shall comply individually with MGO 33.07(7).

If the Contractor cannot comply with the requirements of MGO 33.07, the City Engineer shall designate the Contractor's bid non-responsive and this Contract shall not be awarded to the Contractor. The Contractor shall promptly provide the City Engineer with addition information as required by the City Engineer to substantiate the means in which the Contractor intends to comply with MGO 33.07(7).

The Contractor shall insure that each subcontractor used complies with MGO 33.07(7). For each Subcontractor used, the Contractor shall provide all the information required of the General Contractor as indicated above. This information shall be provided prior to beginning work on the Contract. The Contractor shall not subcontract any portion of this contract to a Subcontractor who cannot comply with the provisions of MGO 33.07(7).

If the Contractor cannot provide the City Engineer sufficient information to substantiate the Contractor's compliance with MGO 33.07(7) within four (4) days of the bid opening as determined by the City Engineer, the City Engineer may designate the bid unresponsive.

If the City Engineer designates the Contractors bid unresponsive, the City Engineer shall notify the Contractor in writing that the Contractor's bid has been designated unresponsive. The City Engineer's decision shall be final and conclusive in all matters unless within ten (10) days after such decision the Contractor applies in writing to the Board of Public Works for a review of such decision.

### **102.13 Equal Benefits Requirement (Sec. 39.07, MGO).**

This provision applies to contracts executed by the City on July 1, 2012 or later, unless exempt by Sec. 39.07 of the Madison General Ordinances (MGO).

For the duration of this Contract, the Contractor agrees to offer and provide benefits to employees with domestic partners that are equal to the benefits offered and provided to married employees with spouses, and to comply with all provisions of Sec. 39.07, MGO. If a benefit would be available to the spouse of a married employee, or to the employee based on his or her status as a spouse, the benefit shall also be made available to a domestic partner of an employee, or to the employee based on his or her status as a domestic partner. "Benefits" include any plan, program or policy provided or offered to employees as part of the employer's total compensation package, including but not limited to, bereavement leave, family medical leave, sick leave, health insurance or other health benefits, dental insurance or other dental benefits, disability insurance, life insurance, membership or membership discounts, moving expenses, pension and retirement benefits, and travel benefits.

Cash Equivalent. If after making a reasonable effort to provide an equal benefit for a domestic partner of an employee, the Contractor is unable to provide the benefit, the Contractor shall provide the employee with the cash equivalent of the benefit.

Proof of Domestic Partner Status. The Contractor may require an employee to provide proof of domestic partnership status as a prerequisite to providing the equal benefits. Any such requirement of proof shall comply with Sec. 39.07(4), MGO.

Notice Posting, Compliance. The Contractor shall post a notice informing all employees of the equal benefit requirements of this Contract, the complaint procedure, and agrees to produce records upon request of the City, as required by Sec. 39.07, MGO.

Subcontractors. Contractor shall require all subcontractors, the value of whose work exceeds the single-trade minimum set forth in Sec 33.07(7)(b)5., MGO, to provide equal benefits in compliance with Sec. 39.07, MGO.

See Section 39.07 MGO for exemptions from this requirement. Exemptions from this requirement include a Contractor whose employees are under a collective bargaining agreement that was in effect prior to July 1, 2012, however, the Contractor must agree to propose to the applicable collective bargaining unit(s) that an equal benefit requirement consistent with this ordinance be incorporated into the next collective bargaining agreement or in the existing agreement upon amendment, extension or other modification that occurs after July 1, 2012.



## **ARTICLE 103 - AWARD AND EXECUTION OF THE CONTRACT**

---

### **103.1 Consideration of Proposals.**

The proposals received will be compared on the basis of the summation of the products of the quantities of work listed and the contract unit prices offered. In case of discrepancy between the gross sum shown in the proposal and that obtained by adding the products of the quantities of work and the unit prices, the unit prices shall govern and any errors found in said products and summation shall be corrected.

### **103.2 Award of Contract.**

All bids shall remain open for forty (40) calendar days after the day of bid opening. Award will be made to the lowest responsible bidder submitting a conforming bid, unless all bids are rejected.

### **103.3 Execution of Contract and Bond.**

The Contractor shall within ten (10) days after the date of the notice of award of the contract, properly execute, on the forms provided, the Agreement and the Payment and Performance Bond, and submit an approved Affirmative Action Plan or Certificate of Compliance. All contracts shall be fully executed in duplicate except that the Engineer may require additional copies when deemed necessary. All numbers, words, and signatures in the Agreement and Bond shall be written with ink.

Within fourteen (14) days of receipt of the executed contract, including the approved Affirmative Action Plan or Certificate of Compliance, the Mayor of the City of Madison shall execute the contract on behalf of the City of Madison. The contract shall not become operative prior to its execution by the Mayor.

### **103.4 Failure to Execute Contract.**

Failure on the part of the successful bidder to execute the contract or an acceptable Payment and Performance Bond, within ten (10) days after the date of notice of the award of the contract will, at the discretion of the Board of Public Works be just cause for the annulment of the award and the forfeiture of the Bid Deposit to the City, not as a penalty but in payment of liquidated damages sustained as a result of such failure.

### **103.5 Payment and Performance Bond.**

The Contractor shall file with the City prior to the time of execution of the contract a Payment and Performance Bond on the prescribed form in the full amount of the contract price as security for the payment of all persons supplying labor, services, and materials for the execution of the work and the faithful performance of the contract. The bond shall remain in effect for a period of one year after the date of Certificate of Substantial Completion. The surety furnishing this bond shall have a sound financial standing, a record of service satisfactory to the City, and shall be authorized to do business in the State of Wisconsin.

## **ARTICLE 104 - SCOPE OF WORK**

---

### **104.1 Lands for Work.**

The City shall provide the lands upon which the work under this contract is to be done except that the Contractor shall provide land required for the erection of temporary construction facilities and storage of his materials, together with right of access to same.

### **104.2 Intent and Coordination of Contract Documents.**

The intent of the plans and Specifications is to provide for the construction, execution and completion of a complete work or improvement which the Contractor undertakes to do in full compliance with the plans, Specifications, Supplemental Specifications, special provisions and contract. The Contractor shall perform all items of work covered and stipulated in the proposal and perform altered and extra work, all in accordance with the lines, grades, typical sections, and dimensions given, and shall furnish, unless otherwise provided in the contract, all materials, implements, machinery, equipment, tools, supplies, transportation, and labor necessary to the prosecution and completion of the work.

The contract documents are complimentary, and what is called for by any one shall be as binding as if called for by all. Materials or work described in words which so applied have a well-known technical or trade meaning shall be held to refer to such recognized standards.

In the event of a discrepancy between the drawing and the figured dimensions thereon, the figured dimensions, unless obviously incorrect, shall govern over scaled dimensions. In the case of a discrepancy between the Supplemental Specifications and these Specifications, the Supplemental Specifications shall govern; between the plans and these Specifications or the Supplemental Specifications, the plans shall govern; and between the special provisions and these Specifications, Supplemental Specifications or the plans, the special provisions shall govern. The latest issue of an Addendum to the Standard Specifications shall prevail over previously issued Standard Specifications whenever in conflict therewith.

The Contractor shall take no advantage of any apparent error or omission in the plans or Specifications, and the Engineer shall be permitted to make such corrections and interpretations as may be deemed necessary for the fulfillment of the intent of the plans and Specifications.

### **104.3 Changes in the Work.**

The Engineer shall have the right to make alterations in the line, grade, plan, form or dimensions of the work herein contemplated, including the lengthening or shortening of the project, either before or after the commencement of the work and without notice to the sureties. Such alterations shall, insofar as practical, be ordered in writing before starting work on such alterations.

Except as otherwise provided in Sections 104.4, 104.5, and 104.6 below, whenever the quantity of any item of work as given in the proposal shall be increased or decreased as required to satisfactorily complete the work, payment for such item of work shall be made on the basis of the actual quantity completed at the original contract unit price.

Compensation for alterations in plans or quantities of work requiring contract change orders shall be as stipulated in such agreements.

#### **104.4 Increased or Decreased Quantities.**

It is agreed and understood that the quantities of any items of work shown on the plans or in the proposal are subject to increase or decrease during the progress of the work. The Engineer reserves the right to increase or decrease the quantities of any items of work, including increase or decrease of quantities by alteration of plans, as may be considered necessary or desirable during the progress of the work to satisfactorily complete the construction. Such increases or decreases in quantities shall not be considered as a waiver of any conditions of the contract nor invalidate any of the provisions thereof.

#### **104.5 Increased Items.**

Unless otherwise designated in the proposal, any increase of the contract shall be limited to fifteen (15) percent of the lump sum contract price submitted by the Contractor. Any item may be increased up to twenty-five (25) percent of the original quantity in the contract, but in no case may such an increase exceed in dollar value fifteen (15) percent of the original lump sum contract price bid. If it is determined by the Engineer that increases in excess of those mentioned above will prevail, then the Engineer along with the Board of Public Works shall: (a) renegotiate the unit price for all estimated work over the percentage limit shown above, or (b) advertise for and receive bids for estimated excess work. Unforeseen items of extra work not included in the proposal as a bid item shall be included when calculating the total amount of increase over the original lump sum contract price bid.

#### **104.6 Decreased and Deleted Items.**

Unless otherwise designated in the proposal, the quantity of any item may be decreased, and the actual quantity installed and accepted will be paid for at the contract unit price. Such decrease shall not constitute the basis for a claim for damages for anticipated profits for the work dispensed with. When the reduction in amount is a material part of the work contemplated for the project, the Contractor shall be entitled to compensation as determined by the Engineer for overhead and equipment charges incurred in expectation of the quantity of work originally estimated, unless specifically provided herein.

The right is reserved to delete from the work any item or portion thereof found unnecessary to the improvement. Such deletion shall not constitute the basis for a claim for damages for anticipated profits for the work dispensed with. The Contractor will be paid for all work done toward the completion of the item or portion thereof prior to such deletion a fair and equitable amount covering all items of cost incurred prior to the date of deletion of the work by order of the Engineer. Acceptable materials ordered by the Contractor, and not canceled prior to the date of deletion of the work, and which are delivered on the work, will be paid for at the actual cost to the Contractor, and shall become the property of the City. The Contractor shall be reimbursed for any money expended in preparation for work on any deleted item or portion thereof when such preparation has no value to the remaining items of the contract, or for a proportionate amount based on the total contract price over which such preparation would ordinarily be distributed when other items are included in such preparation.

#### **104.7 Extra Work.**

In connection with the work covered by the contract, the Engineer may, at any time during its progress, order other work or materials incidental thereto. All such work and materials that do not

## Part I - General Conditions

appear in the proposal or contract as a specific item accompanied by a unit price, and which are not included under the price bid for other items in the contract, shall be designated as Extra Work. Extra Work may also consist of additions to or changes in design in contract items or portions thereof, when such additions are wholly disassociated from or outside the scope of the work as evidenced by the plans, special provisions and Specifications, and when the work caused by such additions or changes in design must be performed under conditions or in a manner that is materially and inherently different from the conditions and manner existent for such contract items as contemplated in the original scope of the work. The Contractor hereby agrees to perform Extra Work whenever it is deemed necessary or desirable by the Engineer to complete the project as originally contemplated, or as subsequently altered, and it shall be done in accordance with the requirements herein set forth.

Extra Work shall be done under the supervision of the Engineer, and the Engineer's decision shall be final and binding. The plan of the work to be followed, the equipment to be used, and the amount and character of labor to be employed shall meet with the approval of the Engineer.

The Contractor shall not perform any Extra Work until a contract change order has been authorized. Claims for compensation for Extra Work performed which has not been authorized and not covered by contract change order may be rejected.

The contract change order for Extra Work may provide for payment in an agreed lump sum for the Extra Work performed, on an agreed unit price basis for the units of such Extra Work performed. Where agreement cannot be reached to pay for Extra Work on either the lump sum basis or the unit price basis, the Engineer may direct that payment for Extra Work be determined on a force account basis.

Prices for Extra Work to be completed by subcontractors shall be the subcontractor's actual prices submitted for the work contemplated to which the general contractor may add an amount equal to, but not to exceed, five (5) percent thereof.

For Extra Work to be paid for on a force account basis, the actual cost computed in accordance with the terms of the contract change order shall include such costs and allowances and subject to such limitations as hereinafter provided:

1. For all labor and supervisors in direct charge of the specific work, the Contractor shall receive the rate of wage agreed upon in writing before beginning work, for each and every hour that said labor and supervisors are actually engaged in such work.

The Contractor shall receive the actual costs paid to, or in behalf of, laborers by reason of health and welfare benefits, pension fund benefits or other benefits required to be paid.

An amount equal to thirty-five (35) percent of the above items will be added to the cost of such items.

2. For property damage, liability, and worker's compensation insurance premiums, unemployment insurance contributions and social security taxes on the force account work, the Contractor shall receive the actual cost, to which cost shall be added an amount equal to fifteen (15) percent of the sum thereof. The Contractor shall furnish satisfactory evidence of the rate or rates paid.

Part I - General Conditions

3. For materials accepted by the Engineer and used, the Contractor shall receive the actual cost of such materials delivered to the work including transportation charges (exclusive of machinery rentals as hereinafter set forth), to which cost shall be added an amount equal to fifteen (15) percent of the sum thereof.
4. For any machinery or special equipment (other than small tools) including fuel and lubricants, the use of which has been authorized by the Engineer, the Contractor shall receive the rental rates agreed upon in writing before such work is begun, for the actual time that such equipment is in operation on the work, and to which rental sum no percentage shall be added.
5. No additional allowance shall be made for general superintendence, the use of small tools, or other costs of which no specific allowance is herein provided.
6. For administration cost when work is performed by an approved subcontractor, the Contractor shall receive an amount equal to five (5) percent of the total costs of such work computed as set forth above.
7. The compensation as set forth above shall be received by the Contractor as payment in full for Extra Work done on a force account basis. At the end of each day the Contractor's representative and the inspector shall compare records of the cost of work done as ordered on a force account basis.
8. No payment will be made for work performed on a force account basis until the Contractor shall furnish to the Engineer duplicate itemized statements of the cost of such force account work, detailed as to the following:
  - a. Name, classification, dates, daily hours, total hours, rate and extension of each laborer and supervisor.
  - b. Designation, dates, daily hours, total hours, rental rate and extension of each truck and other unit of machinery and equipment.
  - c. Quantities of materials, prices and extensions.
  - d. Transportation on materials.
  - e. Cost of property damage, liability and worker's compensation insurance premiums, unemployment insurance contributions and social security tax.
  - f. Such statements shall be accompanied and supported by original receipted invoices for all materials used and transportation charges; provided, that if materials used on the force account work are not specifically purchased for such work, but are taken from the Contractor's stock, then in lieu of the original invoices, the statements shall contain or be accompanied by an affidavit of the Contractor, certifying that such materials were taken from stock, that the quantity claimed was actually used, and that the price and transportation claimed represents the actual cost to the Contractor.

No verbal order or suggestions given by an employee of the City shall be construed as authorizing or laying the basis for any claim on the part of the Contractor for extra

compensation, either for Extra Work or materials, or for damages, because of the Contractor's compliance therewith. Such verbal orders and suggestions as to the performance of the work may be freely given, but in case they appear to the Contractor to involve Extra Work, for which the Contractor should receive extra compensation, the Contractor shall obtain a written order from the Engineer for such Extra Work prior to performing the work. In case of a dispute as to what does or does not constitute Extra Work, a decision will be made by the Engineer.

#### **104.8 Removals.**

The Contractor shall remove existing structures or parts thereof when specified in the contract and such removal shall be incidental to other bid items unless a separate bid is taken for the removal of such structures. The removal of such structures or parts thereof, when not specified in the contract but subsequently required, shall be paid for as Extra Work.

The Contractor shall dispose of all materials removed at locations specified in the contract.

#### **104.9 Old Material.**

All old material shall be the property of the City.

Should any of the old material be suitable for the new work, the same will be used by the Contractor as directed by the Engineer. In case any old material is reused in the work, an amount equal to the cost of a like quantity of new material of the same kind will be deducted from the contract price.

#### **104.10 Cleaning Up.**

The Contractor shall, as directed by the Engineer, remove from the City's property and from all public and private property, at the Contractor's expense, all temporary structures, rubbish, and waste materials resulting from the Contractor's operations.

It shall be the responsibility of the Contractor to keep all streets in the area free from mud, clay, gravel, and other materials which vehicles or equipment may track or scatter onto the street or which may be deposited by uncontrolled drainage of water directly onto the streets. The Contractor shall not allow vehicle tires to track earth, gravel or other materials onto streets. Access to the site may be prohibited if and when necessary to accomplish that purpose. It is required that vehicles be loaded in such a manner as to avoid any spillage of earth or other materials onto streets while hauling them from or to the site. Should the Contractor fail to comply with this requirement after twenty-four (24) hours written notice of noncompliance, then the City may have said streets cleaned. The City will have this work accomplished by the most expeditious means available at the time it is required and not necessarily by the least expensive means when time is of the essence. Cost of said cleaning shall be deducted from the payments due the Contractor.

Concrete trucks or any other equipment shall not be flushed out onto public streets, walks, or gutters. This does not include streets being worked on within the project, unless they are completed pavements.

It shall be the responsibility of the Contractor to inspect all access structures and catchbasins periodically during the life of the project for materials which may be deposited in them due to the

activities of the Contractor and it shall further be the Contractor's responsibility to remove said material immediately at the Contractor's expense.

**104.11 Final Clean Up.**

Upon completion of the work and before acceptance and final payment will be made, the Contractor shall remove from the project area all surplus and discarded materials, rubbish and temporary structures and leave the project area in a neat and presentable condition. The Contractor shall restore, at the cost and expense of the Contractor, all work completed under other contracts which has been damaged by the Contractor's operations, in general conformity with the Specifications for the item or items involved.

The City Inspector and a representative of the Contractor shall inspect the interior of all access structures and catchbasins within the construction limits for debris, construction materials, dirt and stones deposited therein by the activities of the Contractor.

Final clean up shall be considered subsidiary and incidental to the other items of the contract, and no separate or additional compensation will be made therefor.

No project shall be accepted until all excess mud, terrace dirt, asphalt material, rocks and crushed stone have been removed from the sidewalk, terrace, gutter and pavement. Work days may be charged against the Contractor until all clean up is complete and to the satisfaction of the Engineer.

## **ARTICLE 105 - CONTROL OF THE WORK**

---

### **105.1 Authority of the Engineer.**

The Engineer shall resolve all questions which arise as to the quality and acceptability of materials furnished, work performed, manner of performance, rate of progress of the work, interpretation of the plans and Specifications, acceptable fulfillment of the contract, compensation, and disputes and mutual rights between Contractors under the Specifications. The Engineer shall determine the amount and quantity of work performed and materials furnished.

All decisions of the Engineer shall, when so requested, be rendered in writing. They shall be final and conclusive in all matters unless within ten (10) days after such decision the Contractor applies in writing to the Board of Public Works for a review of such decision.

Any change proposed by a Contractor in SBE subcontractors, vendors or suppliers from those SBEs indicated on the SBE Compliance Report must be approved by the Engineer and the City's Manager of the Affirmative Action Division (hereafter, AAD). When requested, such decision shall be rendered in writing. Such decisions shall be final and conclusive in all matters unless within ten (10) days after such decision the Contractor or the affected SBE applies in writing to the Board of Public Works for a review of such decision.

In the event the Engineer and the AAD disagree over the proper decision to be made regarding an SBE, the Mayor shall appoint a third person to resolve the disagreement, within 30 days of appointment. The decision thus rendered may be reviewed by the Board of Public Works upon request of the Contractor or the affected SBE as set forth in Sections 105.1 and 105.2 of the City's standard specifications.

### **105.2 Review of Engineer's Decision.**

When an application for review of the Engineer's decision is presented, the Board of Public Works shall, within ten (10) days thereafter, give opportunity for the Contractor to appear before it and the Engineer, and present evidence bearing upon such decision, and any claims for a modification or reversal thereof.

Said Board shall render its decisions within ten (10) days after such appearance and its decision shall be final unless the Contractor shall, within ten (10) days after receiving the decision, give notice in writing of its intention to file suit in court for final determination of the matter.

### **105.3 Authority and Duties of Inspector.**

Inspectors assigned by the Engineer have authority to inspect all work done and all material furnished. Such inspection may extend to all or any part of the work and to the preparation, fabrication, or manufacture of the materials to be used. An Inspector is not authorized to revoke, alter or waive any requirements of the Specifications. An Inspector is authorized to call the attention of the Contractor to any failure of the work or materials to conform to the Specifications and contract. An Inspector shall have the authority to reject materials or suspend the work until any questions at issue can be referred to and decided by the Engineer.



If the Contractor fails to suspend operations when ordered to do so in writing, the work done after such order is issued may be rejected without payment therefor, as determined by the Board of Public Works.

The Inspector shall in no case act as supervisor or perform other duties for the Contractor, nor interfere with the management of the work done by the latter. Any advice which the Inspector may give the Contractor shall not be construed as binding the Board of Public Works in any way, or releasing the Contractor from fulfilling all of the terms of the contract.

The presence or absence of the Inspector shall not relieve in any degree the responsibility or the obligation of the Contractor to perform the work in accordance with the contract documents.

#### **105.4 Participation by Another Governmental Body.**

When another governmental body is to pay all or a portion of the cost of the work covered by the contract, the work shall be under the supervision of the City but subject to the inspection and approval of the proper official of the other governmental body and in accordance with the applicable Statutes, and rules and regulations made pursuant thereto. Such inspection and approval shall in no sense make the other governmental body a party to the contract, and will in no way interfere with the rights of either party hereunder.

#### **105.5 Inspection of Work.**

The Engineer and all duly authorized representatives shall at all times have access to the work wherever it is in preparation or progress and the Contractor shall provide proper facilities for such access and for inspection. This shall include providing access to the site for the vehicles of the engineer and duly authorized representatives.

The Engineer reserves the right to inspect any and all sewers by the use of closed circuit internal televising system, and to use the data and information obtained in the final determination as to the acceptability of the sewer.

If the Specifications, the Engineer's instructions, laws, Ordinances, or any public authority require any work to be specially tested or approved, the Contractor shall give the Engineer timely notice of its readiness for inspection, and if the inspection is by another authority than the Engineer, of the date fixed for such inspection. Inspections by the Engineer shall be promptly made, and where practicable, at the source of supply. If any work should be covered up without approval or consent of the Engineer, it must, if required by the Engineer, be uncovered for examination at the Contractor's expense.

The Contractor shall promptly remove, rebuild and make good at the Contractor's cost any work which is found to be defectively executed. Any failure to reject work at the time of its construction shall not be construed as an acceptance of defective work. If any doubt exists as to the character of such work, it must, on order of the Engineer, be taken up. If found to be imperfect, it must be made good without additional compensation; if satisfactory the cost of removing and replacing shall be paid as Extra Work.

## **105.6 Contractor's Responsibility for Work.**

Until acceptance of the work by the City in accordance with Section 105.15, the Contractor shall have the charge and care thereof and shall take every precaution against injury or damage to any part thereof by the action of the elements, or from any other cause, whether arising from the execution or nonexecution of the work. The Contractor shall promptly rebuild, repair, restore, and make good all injuries or damages to any portion of the work occasioned by any of the above causes before such acceptance and shall bear the expense thereof, except damage to the work due to unforeseeable causes beyond the control of and without the fault or negligence of the Contractor, including but not restricted to acts of God, of the public enemy, or of governmental authorities.

In case of suspension of work from any cause whatever, the Contractor, prior to suspension, shall take such precautions as may be necessary to prevent damage to the project, provide for normal drainage and shall erect any necessary barricades, signs or other facilities, at the Contractor's expense, as directed by the Engineer.

The Contractor shall give the work the constant attention necessary to facilitate the progress thereof and shall cooperate with the Engineer and other Contractors and/or utilities on or near the work in every way possible. The Contractor shall have at all times during the progress of construction, irrespective of the amount of work sublet, a competent superintendent or designated representative capable of reading and thoroughly understanding the plans and Specifications, as the Contractor's agent on the work, who shall receive instructions from the Engineer. The Contractor's superintendent or designated representative shall have full authority to execute the orders or directions of the Engineer without delay and to supply promptly such materials, tools, plant, equipment and labor as may be required to properly perform the work.

The Contractor shall follow strictly and without delay all instructions and orders given by the Engineer. All such drawings and instructions shall be consistent with the contract documents, and shall be confirmed in writing upon written request in each case. Any orders given by the Engineer to the superintendent or designated representative of the Contractor in the absence of the Contractor shall have the same force and effect as if given to the Contractor.

If the Contractor, in the course of the work, finds any discrepancy between the plans and the physical conditions of the project area or any errors or omissions in the plans or in the layout as given by points and instructions, it shall be the Contractor's duty to immediately inform the Engineer, in writing if required, and the Engineer shall promptly verify the same. Any work done after such discovery, until authorized, will be done at the Contractor's risk. If the Contractor observes that the drawings and Specifications are at variance with laws and regulations, the Contractor shall promptly notify the Engineer in writing and any necessary changes shall be adjusted as provided in the Contract for changes in the work. If the Contractor performs any work knowing it to be contrary to such laws, Ordinances, rules or regulations, and without such notice to the Engineer, the Contractor shall bear all costs arising therefrom.

Neither party shall employ or hire any employee of the other party without the other party's consent.

## **105.7 Contract Documents.**

Unless otherwise provided in the contract documents, the City will furnish to the Contractor, free of charge, all copies of drawings and Specifications reasonably necessary for the execution of the work. The Contractor shall keep one copy of all drawings and Specifications on the project site, in good

order, available to the Engineer. The Engineer shall furnish, with reasonable promptness, additional instructions, by means of drawings or otherwise, necessary for the proper execution of the work.

### **105.8 Working Drawings.**

The approved plans will be supplemented by such working drawings as are deemed necessary to adequately control the work. It is mutually agreed that all authorized alterations affecting the requirements and information given on the approved plans shall be in writing. No changes shall be made on any plan or drawings after the same has been approved by the Engineer, except by direction of the Engineer.

Working drawings shall consist of such detailed plans as may be required for the prosecution of the work and which are not included in the plans furnished by the Engineer.

It is expressly understood that approval by the Engineer of the Contractor's working drawings does not relieve the Contractor of any responsibility for accuracy of dimensions and details, or of mutual agreement of dimensions and details. The Contractor shall be responsible for agreement and conformity of the working drawings with the approved plans and Specifications.

The contract price shall include the cost of furnishing all working drawings and the Contractor will be allowed no extra compensation for such drawings.

### **105.9 Surveys, Points and Instructions.**

The City shall make all surveys unless otherwise specified in the contract.

The Engineer will furnish and set the construction survey stakes or reference points and bench marks necessary to establish the location, alignment and elevation for the project and such stakes will bear instructive markings or be accompanied by necessary detailed instructions. These stakes and marks shall constitute the field control by and in accordance with which the Contractor shall govern and execute the work. The Contractor shall furnish, such other facilities and labor as may be required in establishing such other points and lines necessary to the prosecution of the work. The Contractor shall furnish additional stakes and other material necessary for maintaining the points and lines given. The Contractor shall be responsible for the preservation of all stakes and marks, and if any of the survey stakes or marks have been carelessly or willfully destroyed or disturbed by the Contractor, the cost to the City of replacing them may be charged against the Contractor and be deducted from the payment of the work.

The Contractor shall provide reasonable and necessary opportunities and facilities for setting points and making measurements. The Contractor shall make timely demands upon the Engineer for such points and instructions as may be necessary as the work progresses. The Contractor shall not proceed until the Engineer has had the opportunity to furnish such points and instructions. The work shall be done in strict conformity with such points and instructions.

### **105.10 Conformity with Plans and Specifications.**

All work performed and all materials furnished shall be in conformity with the lines, grades, cross sections, dimensions and materials requirements shown on the plans or indicated in the Specifications. It shall be finished to produce quality work and appearance within limits of precisions expected of good construction.

The lines, grades, typical sections, and dimensions shown on the plans are subject to adjustment by the Engineer during construction, but any deviation of a character not contemplated or provided for in the plans, Specifications or working drawings that may be required to successfully complete the project will be determined by the Engineer and authorized in writing.

In the event the Engineer finds the materials or the finished product in which the materials are used not within conformity with the plans and Specifications, the Engineer shall then make a determination whether or not acceptable work has been produced and can be accepted and remain in place. If the Engineer determined that acceptable work has been produced and can be accepted and remain in place, the Engineer will document the basis of acceptance by contract modification or as provided elsewhere in these Specifications which will provide for an appropriate adjustment in the contract price for such work or materials, either as the Engineer deems necessary to conform to his determination based on engineering judgment, or as specifically provided for elsewhere in these Specifications.

In the event the Engineer finds that the materials or the finished product in which the materials are used or the work performed are not in conformity with the plans and Specifications and have resulted in an inferior or unsatisfactory product, the work or materials shall be removed and replaced or otherwise corrected by and at the expense of the Contractor. This expense includes total and complete restoration of any disturbed surface to original or better than original condition which existed before the repairs or replacement, regardless of improvements on lands where the repairs or replacement is required.

#### **105.11 Removal of Unauthorized and Unacceptable Work.**

Work performed without lines and grades being given, work performed beyond the lines and grades shown on the plans, or as given, except as herein provided, or any Extra Work performed without authority, will be considered as unauthorized and may not be measured or paid for by the City. Work so done may be ordered removed or replaced at the Contractor's expense.

Work which is not in conformity with the plans and Specifications and which results in an inferior or unsatisfactory product will be considered as unacceptable work.

Unacceptable work, whether the result of poor workmanship, use of defective materials, damage through carelessness or any other cause, found to exist prior to the final acceptance of the work, shall be immediately removed and acceptably replaced or otherwise satisfactorily corrected by and at the expense of the Contractor. This expense includes total and complete restoration of any disturbed surface to original or better than original condition which existed before the repairs or replacement, regardless of improvements on lands where the repairs or replacement is required.

Upon failure on the part of the Contractor to comply forthwith with any written order of the Engineer made under the provisions of this Section, the Engineer will have authority to cause unauthorized work to be removed or replaced and unacceptable work to be remedied or removed and replaced and to deduct the cost thereof from any monies due or to become due the Contractor.

#### **105.12 Cooperation by Contractor.**

The City reserves the right at any time to contract for and perform other or additional work on or near the work covered by any contract.

The Contractor shall arrange and conduct the work so as not to interfere with the operations of other contractors engaged upon or near the work and to join the work to that of others in a proper manner, and in accordance with the spirit of the plans and Specifications, and to perform the work in the proper sequence in relation to that of other work, all as may be directed by the Engineer.

If any part of the Contractor's work depends for proper execution or results upon the work of any other contractor, the Contractor shall inspect and promptly report to the Engineer any defects in such work that render it unsuitable for such proper execution and results. The Contractor's failure to inspect and report shall constitute an acceptance of the other contractor's work as fit and proper for the reception of the Contractor's work, except as to defects which may develop in the other contractor's work after the execution of the Contractor's work.

The Contractor, in performing work related to the contract, shall be held responsible for any damage done to the work performed by another Contractor. Each Contractor shall so conduct operations and maintain the work in such condition that adequate drainage shall be in effect at all times.

In case of a dispute arising between two or more Contractors engaged on the same improvement as to the respective rights of each under the Specifications, the Engineer shall determine the matters at issue and shall define the respective rights of the various interests involved in order to secure the completion of all parts of the work in general harmony and with satisfactory results. The Engineer's decision shall be final and binding on all parties concerned and shall not in any way be a cause for claims for extra compensation by any of the parties.

The right to construct or reconstruct any utility services in the highway or street, or to grant permits for the same, at any time, is hereby expressly reserved by the City, and the Contractor shall not be entitled to any damages either for the digging up of the street or for any delay occasioned thereby. Upon the presentation of a duly authorized and satisfactory permit which provides that all necessary repair work will be paid for by the party to whom such permit is issued, the Engineer may authorize the Contractor to allow parties bearing such permits to make openings in the street. The Contractor shall, when ordered by the Engineer in writing, make in an acceptable manner all necessary repairs due to such openings and such necessary work ordered by the Engineer shall be paid for at contract prices or on the basis of Extra Work as provided for in the Specifications and shall be subject to the same conditions as original work performed.

When indicated on the plans or Specifications or when directed by the Engineer or Inspector, the Contractor shall provide the City adequate opportunity to install all traffic signal loops in the stone base course or asphaltic lower layer before paving or final paving. The Contractor shall install the necessary loop lead duct conduit and signal pull boxes prior to the City installing the loop detector wires and shall coordinate construction operations with the City. The Contractor shall provide a minimum twenty-four (24) hours and a maximum forty-eight (48) hours advance notice to the Traffic Engineering Electrical Supervisor, Madison Traffic Engineering Shop (608-266-4767), prior to final compaction and trimming of the stone base course or asphaltic upper layer paving. The City shall be allowed twenty-four (24) hours to install the loop detector wires after such compaction and trimming or asphaltic lower layer paving is completed. Cost to repair damage to traffic signal loops that occur after their installation due to Contractor negligence, and the cost for all work to install loop detector wires in the asphaltic upper layer due to improper notice to the Traffic Engineering Electrical Supervisor will be deducted from the contract.

### **105.13 Order of Completion.**

The Contractor shall complete any portions of the work in such order of time as has been stated in the contract or in such order as the Engineer may declare necessary by reason of an emergency.

### **105.14 Use of Completed Portions.**

The City shall have the right to take possession of and use any completed or partially completed portion of the work, notwithstanding the time of completing the entire work or such portions, may not have expired. If such prior use increases the cost of, or delays the work, the Contractor shall be entitled to such extra compensation, or extension of time, or both as the Engineer may determine.

### **105.15 Substantial Completion.**

When the Contractor considers the entire work completed, the Contractor shall notify the Engineer, in writing, that the work is complete and request that the Engineer conduct an inspection of the work. Within a reasonable time thereafter the Contractor and the Engineer shall make an inspection of the work to determine the status or completion. If the Engineer does not consider the work complete, the Engineer will notify the Contractor, in writing, of the reasons therefor. At this time any defects or imperfections that appear in the whole or any part of the work, which are caused by or due to any fault or negligence of the Contractor, the same shall be corrected before the work will be deemed substantially complete. Upon completion of the work to repair the defects and imperfections by the Contractor, the Contractor shall notify the Engineer, in writing, that the work has been completed. If, upon inspection, the work is found to be satisfactory by the Engineer, a certificate of substantial completion will be issued.

No project shall be considered complete until all excess mud, terrace dirt, asphalt material, rock and crushed stone have been removed from the sidewalk, terrace, gutter and pavement; inlets and storm sewers cleaned; and erosion control is in place. Work days may be charged against the contractor until all cleanup and repair of defects and imperfections are completed.

### **105.16 Guarantee.**

Unless otherwise stated in the special provisions, the Contractor shall guarantee the work performed under this contract for a period of one year from the date of Certificate of Substantial Completion against defects in workmanship or materials, all in accordance with Section 105.15, "Substantial Completion." If any defect should appear during the guarantee period, the Contractor shall make required replacement or acceptable repairs of the defective work at the Contractor's expense. This expense includes total and complete restoration of any disturbed surface to original or better than original condition which existed before the repairs or replacement, regardless of improvements on lands where the repairs or replacement is required. The Payment and Performance Bond shall remain in force during this guarantee period. This guarantee is in addition to any other rights and remedies the City may have.

## **ARTICLE 106 - CONTROL OF MATERIALS**

---

### **106.1 Source of Supply and Quality.**

The Specifications require the use of new, high quality materials throughout the work, except as may specifically be provided elsewhere in the Specifications, on the plans, or in the special provisions, incorporated in the work in such a manner as to produce completed construction which is workmanlike and acceptable in every detail.

Only approved materials shall be incorporated into the work. The permitted use of an untested material shall not be construed as implied approval of the material, and such use shall be at the Contractor's risk pending completion of subsequent tests made on representative samples of the material.

Fabricated materials obtained by the Contractor from a manufacturer or a supplier shall, at the Engineer's discretion, be subject to approval before delivery of the material to the job site. Furthermore, the Contractor may be required to obtain material from another approved source, if it is determined that the product of a manufacturer or supplier is not of satisfactory uniformity or consistent quality.

In the case of materials obtained or produced from natural deposits, either commercially or by the Contractor, the Contractor shall obtain the Engineer's preliminary approval of the source.

The Contractor shall furnish samples as required, representative of the material proposed for the work, in sufficient time to permit testing as necessary to establish a basis for approval. Such samples shall be obtained under the observation of, and with methods approved by the Engineer.

Tests will be made on these preliminary samples and reports rendered, but it is to be understood that such tests are for information only and that any preliminary approval based thereon shall not be construed as a guaranty for acceptance of any material which may be delivered later for incorporation into the work.

Only the materials actually delivered for the work will be evaluated, and their acceptance or rejection will be based solely on the results of the tests prescribed in the Specifications.

The Contractor shall assume full responsibility for the furnishing of uniform and satisfactory materials. When materials are obtained from local deposits, the Contractor shall be responsible for any losses or damages resulting from the opening and operation thereof, or from the failure of the deposit after development to produce acceptable materials.

### **106.2 Plant Inspection.**

The Engineer may undertake the inspection of materials at the plant (point of manufacture or source of supply), if necessary, or another agency may be designated for the purpose.

In the event plant inspection is undertaken, the following conditions shall be met:

1. The Engineer shall have the cooperation and assistance of the Contractor and producer.

## Part I - General Conditions

2. The Engineer shall have free entry at all times to such parts of the plant as may involve the manufacture or production of the materials being furnished.
3. If required by the Engineer, the Contractor shall arrange for acceptable working space in or near the plant for use by the Inspector. Such space shall be independent of space used by the material producer.
4. The Contractor shall give the Engineer sufficient advance notice of production schedules to permit making necessary arrangements.
5. Adequate safety measures shall be provided and maintained.

The right is reserved by the City to retest or reinspect plant inspected materials after delivery to the job-site and to reject any which are found not to comply with the contract requirements.

### **106.3 Samples and Tests.**

To ascertain if materials comply with contract requirements samples shall, at the discretion of the Engineer, be taken at the source or at job destination, and as often as the Engineer deems it advisable or necessary. The taking of samples shall be in accordance with standard practices, except where methods and procedures for sampling a material are otherwise set forth in the Specifications.

The Contractor shall furnish without charge all samples required by the Engineer and shall afford such facilities as may be required for collecting and forwarding them. The Contractor may be required to furnish, when requested by the Engineer, a written statement giving the origin, composition or process of manufacture of a material.

In lieu of making tests, the Engineer may, in the case of commercial products, accept the manufacturer's Certified Report of Test of Analysis or a Certificate of Compliance. The samples for the tests or analyses reported on in the Certified Report of Test or Analysis may be those normally obtained in a formal product quality control program or obtained to represent the specific lot of material furnished when no formal control program is in effect, or those required to be obtained by Specifications.

Unless otherwise provided in the contract, it shall be the intent of these Specifications that conformity of materials to the specified requirements shall be at the time, or just prior to the time, they are incorporated into the work.

All tests shall be made in accordance with the methods described and designated herein or in the contract. Reference to ASTM Specifications shall be understood to mean the Standards or Tentative Standards of the American Society for Testing and Materials. References to A.R.E.A. Specifications shall be understood to mean the American Railway Engineering Association, Construction and Maintenance Section, Association of American Railroads, Manual. Reference to the AASHTO Specifications shall be understood to mean the Standard or Interim Specifications for Highway Materials and Methods of Sampling and Testing of the American Association of State Highway and Transportation Officials. Unless otherwise designated, references to various standard specifications and test methods shall be understood to mean the specification or test method which is current on the date of advertisement for bids.



Test results obtained by the City on samples of materials furnished by the Contractor shall be available to the Contractor.

**106.4 Storage of Materials.**

Materials shall be so stored as to insure the preservation of their quality and suitability for the work. Stored materials, even though approved before storage, shall be subject to inspection prior to their use in the work and shall meet the requirements of the contract at the time they are used. Stored materials shall be located so as to facilitate inspection. With the Engineer's approval, portions of the right-of-way not required for public travel may be used for storage purposes and for the placing of the Contractor's plant and equipment, but any additional space required shall be provided by the Contractor at the Contractor's expense. Contractor's equipment shall not be secured in any way to a street or park tree trunk.

**106.5 Defective Materials.**

All materials which are not in conformity with the requirements of the Specifications shall be considered defective and shall be rejected. Rejected materials shall be removed from the site of the work unless otherwise permitted by the Engineer. Any defective materials which have been subsequently corrected shall not be used or accepted until reevaluated and approved by the Engineer.

Materials which have been incorporated in the work and subsequently found to be defective may be left in place with the permission of the Engineer, after the Engineer's determination that reasonably acceptable work has been produced. An appropriate deduction will be made in the contract price for such materials or for the work in which such defective materials are incorporated.

## **ARTICLE 107 - PROTECTION OF PUBLIC AND UTILITY INTERESTS**

---

### **107.1 Public Convenience and Safety.**

The Contractor shall avoid as far as possible the maintenance of any condition which might be deemed at law to be an “attractive nuisance”. Where such condition is unavoidable or where apparent or potential hazards occur incident to the Contractor’s conduct of the work, the Contractor shall maintain a proper watch or provide other reasonable safeguards. The Contractor and its surety shall be responsible for all damage, bodily injury, or death arising through the Contractor’s negligence either in maintaining an attractive nuisance or otherwise.

Fire hydrants shall be visible and accessible from the street at all times to the Fire Department. No material or other obstructions shall be placed within ten (10) feet of a fire hydrant.

The Contractor shall strictly adhere to Section 182.0175, Wis. Statutes, regarding notification and location of utilities, including but not limited to three working days advance notice.

When directed by the Engineer, the Contractor shall uncover utility lines within the proposed construction limits well in advance of the construction. The grade of the utility lines shall be determined by the Engineer, and the utility companies will be advised by the Engineer as to their adjustment required. The Contractor shall then backfill and maintain the openings. Costs of this work shall be included in the unit price bid for Utility Line Openings as provided for in Measurement and Payment for Utility Line Openings in Part 5 of these Specifications.

In the case of horizontal boring construction within the Right-Of-Way, the Contractor shall verify that no damage was done to storm sewer mains, sanitary mains and laterals which were crossed, when directed by the Engineer. This may be accomplished by uncovering the line prior to boring or televising the line after boring. In addition, the Contractor may wish to televise the line before boring to verify the existing condition of the pipe. If the Contractor decides not to televise prior to boring, any damage to the pipe shall be considered the responsibility of the Contractor and shall be repaired by the Contractor at their expense. All costs associated with exposing and or televising storm sewer mains, sanitary mains and laterals shall be the responsibility of the Contractor. The Contractor shall coordinate access to homes in order to televise laterals. The video tape shall be date and time stamped and provided to the City Engineer within 24 hours of televising.

The Contractor shall obtain all available information in regard to new utilities and new cables, conduits and transformers, planned for installation concurrent with the improvements, and make proper provision and give proper notification so that new utilities and electrical equipment can be installed at the proper time without delay to the Contractor or unnecessary inconvenience to the owner. The location of new underground utilities and electrical equipment, planned to be installed concurrently with the improvement, shall not be covered with pavement prior to the installation of such facilities.

The Contractor shall schedule the operations so as to cause a minimum of interruption, interference or disturbance to the operation of stores, businesses, office buildings, hotels, churches, etc., and to allow access by pedestrians and emergency, delivery and service vehicles at all times.

The Contractor shall restore parking immediately on the street or portions of the street when construction is expected to be delayed for more than one week regardless of the cause unless the Engineer finds that it is not in the public’s best interest to restore the parking.

## Part I - General Conditions

Any temporary shutdown of existing services, i.e., sewers, water, gas, electrical power and access, as may be required, shall be performed only at such times and for such duration as agreed to by the Engineer. The interruption of services and access shall be conducted in accordance with a program mutually agreed to by the Engineer and the Contractor.

The Contractor shall work such overtime, including extended hours on normal work days, Saturdays, Sundays and holidays, as required by the Engineer to meet the above requirements at no additional cost to the City.

Gasoline or diesel operated equipment shall be equipped with mufflers and insulators to minimize noise.

During times when work will prevent access to driveways, the Contractor shall notify all residents, a minimum of 48 hours in advance, if vehicular access cannot be provided to their property.

The Contractor shall phase the work in such a way that the maximum cumulative total time in which any residential property is completely without driveway access is twenty (20) calendar days. Should the Contractor desire to provide temporary crushed stone driveways in order to comply with the above time constraints, the unit bid price for crushed stone will be paid by the City. It is anticipated this stone will be reused elsewhere in the contract. Notice shall be given in accordance with Section 107.7 - Maintenance of Traffic.

Should the Contractor need to use high early strength concrete to meet the day requirement, no additional compensation shall be paid.

The Contractor shall maintain access to all commercial drives, at all times unless permission is granted in writing to close the drive. This may be done by phasing of drive construction and/or plating of drives. No additional compensation shall be given for plating to maintain access.

The Contractor shall provide access to handicap residents at all times. The City shall compensate the Contractor for providing temporary gravel driveways to handicap residences at the contract unit price for crushed stone.

The contractor shall assist residents with refuse collection. Assistance shall be provided by either: maintaining access for City of Madison collection vehicles to all properties located in the project limits; or hauling all refuse and recyclables to a common location at the end of the project where City of Madison crews can collect the refuse and recyclables.

If sidewalk exists on both sides of any given block, the Contractor shall complete all repairs and reopen the sidewalk on one side of the block before beginning repairs on the opposite side of the block including work at the intersection. The contractor may propose alternatives for construction of sidewalk ramps such as constructing temporary ramps.

The City will refer any call or claim, the substance of which is an event caused by the Contractor, or by any person or company utilized by the Contractor, to the Contractor for handling. Within two (2) business days after contacting the individual, the Contractor shall provide a factual summary of the event giving rise to the call or claim, along with the Contractor's proposed resolution, to the City's Risk Manager or designee.

## **107.2 Protection and Restoration of Property and Property Monuments.**

The Contractor shall use every reasonable precaution to prevent the damage or destruction of corporate, government or private property such as poles, trees, shrubbery, crops and fences adjacent to or interfering with the work; all overhead structures such as wires, cables, etc.; within or outside of the right-of-way.

The Contractor shall notify the owners of all corporate, government or private property which interferes with the work advising them of the nature of the interference, and shall arrange with them for the disposition of such property. The Contractor shall furnish the Engineer upon request with copies of all such notification and final agreements.

The Contractor shall give notice to owners and protect and support all water and gas pipes or other conduits and all railway tracks, buildings, walls, fences or other properties which may be subject to damage or subsidence during the execution of the work. The Contractor's responsibility shall be as prescribed in Section 101.111, Wis. Statutes. The Contractor shall take all reasonable and proper precautions to protect persons, animals and vehicles of the public from injury and wherever necessary shall erect and maintain a fence or railing around any excavation, and place a sufficient number of amber lights about the work and keep them burning from twilight until sunrise. The Contractor shall employ one or more watchpersons as an additional security wherever they are needed.

The Contractor shall not in any way prevent the flow of water in the gutters of the street, and shall use proper means to permit the flow of surface water along the gutters while the work is progressing.

The Contractor shall be responsible for the damage or destruction of property of any character resulting from neglect, misconduct, or omission in the manner or method of execution or nonexecution of the work, or caused by defective work or the use of unsatisfactory materials, and shall restore such property to a condition similar or equal to that existing before such damage or injury was done, by repairing, rebuilding, or replacing it as may be directed, or the Contractor shall otherwise make good such damage or destruction in an acceptable manner. If the Contractor fails to do so, the Engineer may, after the expiration of a period of forty-eight (48) hours after giving notice to the Contractor in writing, proceed to repair, rebuild or otherwise restore such property as may be deemed necessary, and the cost thereof shall be deducted from any compensation due or which may become due the Contractor under the contract.

The Contractor shall be responsible for all costs for the repair of underground pipes, wires, or conduits damaged by the Contractor's employees or subcontractors during the construction of the project.

The Contractor will be liable for all damage caused by fires and shall under no consideration start fires without first securing the necessary permits and the approval of the authority having jurisdiction even though the Contractor may be ordered or required to do such burning. In burning brush, stumps, or rubbish, care must be taken not to damage any standing trees, shrubs or other property.

The City reserves the right to impose gross vehicle weight and axle load limits where in its judgment the integrity of existing streets may be threatened.

The Contractor shall not grade, excavate, store material or equipment, or otherwise disturb the area in the vicinity of any tree located in the terrace without prior permission from the Engineer or City

## Part I - General Conditions

Forester. All work done in the vicinity of any tree located in the terrace shall be completed in accordance with section 107.13 Tree Protection Specification.

No ropes, cables, or guys shall be fastened to or attached to any tree for anchorage.

### 107.2(a) Public Land Survey Monuments

#### Preserve Existing Monument

The Contractor shall protect and carefully preserve all land boundary property corners, City survey control, and Public Land Survey monuments which exist within the project limits. Any of these three monument types which are disturbed or removed by the Contractor through the negligence or the carelessness of the Contractor's employees or subcontractors, shall be replaced by a Licensed Surveyor at the Contractor's expense. The Contractor shall contact City Surveyor, (267-1971), forty-eight (48) hours prior to any work adjacent to the monument to allow a City Surveyor to confirm the monument location. The City Surveyor shall also be contacted after the work has been completed in order to confirm the monument location has not been compromised.

#### Reset Existing Monument

##### Description

Reset Monument shall include hand excavation around the existing monument, salvage of the existing monument, and excavation (minimum six (6) inch diameter hole for setting the new monument, backfilling the monument. The Contractor shall contact City Surveyor, (267-1971), forty-eight (48) hours prior to excavation. The City Surveyor will set ties based on the existing monument location and coordinate the placement of the new monument.

##### Material

The City of Madison shall supply the new monument and new casting.

##### Method of Measurement

Reset Monument shall be measured as a completed unit.

##### Basis of Payment

The quantity of survey monuments, measured as provided above, shall be paid for at the contract unit price each for Reset Monument. This price shall be payment in full for all excavation around existing monument, removal of existing monument if necessary, excavating for the placement of the city supplied monument, for placing City supplied casting; for furnishing, placing and compacting backfill material, for disposal of surplus materials; and for all labor, tools, equipment and incidentals necessary to complete this item of work as defined above and in SDD 3.12.

### **107.3 Indemnification.**

To the fullest extent permitted by law, the Contractor shall indemnify, defend and hold harmless the City, its officials, officers, agents, employees, and consultants from and against all suits, claims, damages, losses and expenses, direct, indirect or consequential (including but not limited to fees and charges of engineers, architects, attorneys and other professionals and court and arbitration costs)

arising out of or resulting from the performance of the work, provided that any such claim, damage, loss or expense: (a) is attributable to bodily injury, sickness, disease, death, personal injury, or to injury to or destruction of tangible property (other than the work itself) including the loss of use resulting therefrom and, (b) is caused in whole or in part by any negligent act or omission of the Contractor, any subcontractor, any person or organization directly or indirectly employed by any of them to perform or furnish any of the work or anyone for whose acts any of them may be liable, regardless of whether or not it is caused in part by a party indemnified hereunder or arises by or is imposed by law regardless of the negligence of any such party.

In any and all claims against the City, its officials, officers, agents, employees, or consultants, by any employee of the Contractor, any subcontractor, any person or organization directly or indirectly employed by any of them to perform or furnish any of the work or anyone for whose acts any of them may be liable, the indemnification obligation hereunder shall not be limited in any way by any limitation on the amount or type of damages, compensation or benefits payable by or for the Contractor or any such subcontractor or other person or organization under workers' or workmen's compensation acts, disability benefit acts or other employee benefit acts.

The obligations of the Contractor hereunder shall not extend to the liability of the City's consultants or consultants' agents or employees arising out of the preparation or approval of maps, drawings, opinions, reports, surveys, change orders, and designs or specifications.

#### **107.4 Contractor's Liability Insurance.**

It shall be the Contractor's responsibility to see that all of the contract operations incident to the completion of the contract are covered by liability insurance in order that the general public or any representative of the contracting authority may have recourse against a responsible party for injuries or damages sustained as a result of said contract operations. This requirement shall apply with equal force, whether the work is performed by the Contractor, or by a subcontractor or by anyone directly or indirectly employed by either of them.

The Contractor shall not commence work under this Contract, nor shall the Contractor allow any Subcontractor to commence work on its Subcontract, until the insurance required below has been obtained.

##### **107.4(a) Workers' Compensation Insurance.**

The Contractor shall procure and maintain during the life of this Contract, statutory Workers' Compensation Insurance as required by the State of Wisconsin and other applicable laws on employees to be engaged in work at the site of the project under this contract and, in case of any such work sublet, the Contractor shall require the Subcontractor(s) similarly to provide Workers' Compensation Insurance for all of the latter's employees to be engaged in such work unless such employees are covered by the protection afforded by the Contractor's Workers' Compensation Insurance. The Contractor and Subcontractor(s) shall also carry minimum Employers Liability limits of \$100,000 Each Accident, \$100,000 Disease – Each Employee, and \$500,000 Disease – Policy Limit, or those limits necessary to meet underlying Umbrella Liability insurance requirements.

##### **107.4(b) General Liability.**

The Contractor shall procure and maintain during the life of this Contract, Commercial General Liability insurance including, but not limited to, products liability, completed operations, contractual

Part I - General Conditions

liability, and explosion, collapse and underground coverage in an amount not less than \$1,000,000 per occurrence/\$2,000,000 aggregate on a per project basis. Products-completed operations coverage shall be carried for two years after completion of work. Contractor's coverage shall be primary and list the City of Madison, its officers, officials, agents and employees as Additional Insureds.

107.4(c) Auto Liability Insurance.

The Contractor shall procure and shall maintain during the life of this Contract Business Automobile Liability insurance covering owned, non-owned and hired automobiles for limits of not less than \$1,000,000 combined single limit per accident.

107.4(d) Umbrella Liability Insurance.

The Contractor shall procure and maintain during the life of this Contract Umbrella Liability coverage at least as broad as the underlying Commercial General Liability, Business Automobile Liability and Employers Liability with minimum limits of \$5,000,000 per occurrence and aggregate.

107.4(e) Other Insurance.

The City of Madison reserves the right to require Contractor and/or any Subcontractor(s) to procure additional insurance policies depending on the type of work being performed. Such requirements will be noted in the contract documents.

107.4(f) Subcontractor's Insurance.

The Contractor shall insure the activities of his/her Subcontractors in his own policy.

107.4(g) Acceptability of Insurers.

Insurance is to be placed with insurers who have an A.M. Best rating of no less than A- and a Financial Category rating of no less than VII.

107.4(h) Certificates of Insurance.

**Proof of Insurance, Approval.** The Contractor shall provide the City with certificate(s) of insurance showing the type, amount, effective dates, and expiration dates of required policies prior to commencing work under this Contract. Contractor shall provide the certificate(s) to the City's representative upon execution of the Contract, or sooner, for approval by the City Risk Manager. If any of the policies required above expire while this Contract is in effect, Contractor shall provide renewal certificate(s) to the City for approval. Certificate Holder language should be listed as follows:

City of Madison  
ATTN: Risk Management  
210 Martin Luther King, Jr. Blvd. , Room 406  
Madison, WI 53703

The Contractor shall provide copies of additional insured endorsements or insurance policies, if requested by the City Risk Manager. The Contractor and/or Insurer shall give the City thirty (30) days advance written notice of cancellation, non-renewal or material changes to any of the above-required policies during the term of this Contract.

107.4(i) Insurance for the Construction of Buildings.

The City will effect and maintain, Builder's Risk Insurance on a replacement cost basis in an amount equal to the estimated project cost. Coverage includes the building as well as materials stored on the site to be incorporated in the building, including form work in place, form lumber on site, temporary structures, equipment and supplies incidental to the construction of the building. The City's Builders Risk coverage is written on a per building basis and contains a \$25,000 per occurrence deductible. If a loss under the City's Builders Risk policy is caused by the negligence of the Contractor or its Subcontractor(s), the Contractor shall be responsible for paying the City's \$25,000 deductible. The City Engineer has the authority to withhold such deductible from payment due the Contractor. In addition, City Engineer in his/her sole authority shall determine whether the Contractor was negligent in causing the loss and therefore responsible for the City's deductible.

The insured loss, if any, is to be adjusted with and payable to the City.

Machinery and construction equipment, owned or rented by the Contractor, such as, but not limited to, mixers, hoists, cranes, scaffolding, miscellaneous and small tools, canvasses, tarpaulins, forms and shores (the capital value of which is not wholly included in the cost of the work) and Contractor's job office and warehouse, are not covered by this insurance.

This provision shall only apply to the contracts for the construction of buildings.

**107.5 Use of Explosives.**

When blasting is permitted by the Engineer, the Contractor shall use the utmost care to protect life and property. The blasting shall be done only by a blaster licensed for City blasting. The Contractor shall comply with all laws, ordinances, and applicable safety code requirements and regulations relative to the handling, storage and use of explosives and protection of life and property, and the Contractor shall be responsible for all damage thereto caused by the Contractor's or any subcontractor's operations. Signals warning persons of danger shall be given before any blast.

Excessive blasting or overshooting shall not be permitted. The Engineer shall have authority to order any method of blasting discontinued which leads to overshooting or is dangerous to the public or destructive to property or to natural features.

The Contractor shall notify the Supervisor of Mine Safety, State of Wisconsin Department of Commerce, Division of Safety, at least forty-eight (48) hours before any blasting operation begins and shall obtain a permit from the Fire Chief in accordance with Section 34.04, Madison General Ordinances.

Before any blasting shall be done by the Contractor, a certificate of insurance indicating special blasting ("X") coverage shall be filed with the Engineer. All of the requirements specified in Section 107.4 above shall apply to this coverage.

**107.6 Dustproofing.**

The Contractor shall take all necessary steps to control dust arising from operations connected with this contract. When ordered by the Engineer, the Contractor shall dustproof the construction area by sprinkling with water to which has been added calcium chloride at the rate of 400 pounds per 1,000



gallons of water. The Contractor shall be paid at the rate of \$30.00/1,000 gallons of water applied with a sprinkler truck and \$800.00 per ton of calcium chloride so applied. With the Engineer's permission, for limited areas only, the Contractor may control dust by sprinkling with water without the use of calcium chloride, or the calcium chloride may be spread dry by hand.

### **107.7 Maintenance of Traffic.**

When the contract provides that the street or portions thereof undergoing improvement will be closed to through traffic, the Contractor will not be responsible for maintenance of the detour, unless specified in the contract, that may be necessary on adjacent streets for the accommodation of through traffic. The Contractor shall at all times conduct the work in such a manner as to insure the least possible obstruction to local traffic serving abutting properties along the street being improved and to that end shall provide and maintain in reasonably passable conditions such temporary roads and temporary approaches as are deemed reasonable and practical by the Engineer.

When the contract provides for the maintenance of traffic over or along the street while undergoing improvements or reconstruction, the street shall be kept open to all traffic and the Contractor shall keep the portions of the street being used by public traffic in such condition that traffic will be reasonably and adequately accommodated. The Contractor shall provide and maintain in safe and adequate condition temporary approaches, crossings and intersections with roads and necessary driveways. The Contractor shall bear all of the expense of maintaining traffic over the section of street undergoing improvement and the construction and maintenance of such approaches, crossings, intersections and other features as may be necessary without direct compensation except as to those features of such work which are a part of planned, completed construction work.

During the life of the project the Contractor, at locations designated in the contract, shall provide means satisfactory to the Engineer for crossings for the traffic on intersecting streets in a manner which will not interrupt the flow of such traffic or be harmful to the improvement. Temporary bridges for pedestrians shall be provided as required by the plans or special provisions or as ordered by the Engineer over new pavement, sidewalks, trenches, etc., at street intersections.

During a suspension of work under the terms of the contract or authorized by the Engineer due to unfavorable weather or other conditions which are not the fault of the Contractor and which make such suspension advisable, the Contractor shall make passable and shall open to traffic such portions of the street under improvement and such temporary roadways or portions thereof as may be agreed upon between the Contractor and Engineer for temporary accommodation of necessary traffic during the period of suspension. During the period of suspension, the surface maintenance of the travelway of the temporary route or line of travel agreed upon shall be at the expense of the City. When work is resumed, the Contractor shall replace or renew any work or material lost or damaged because of such temporary use of the highway under improvement. The Contractor shall remove, when required, work or material used in the temporary maintenance thereof, and shall complete the improvements in every respect as though its prosecution had been continuous and without interference except as may otherwise have been agreed upon by the Contractor and Engineer at the time arrangement was made for the temporary accommodation of necessary traffic during the anticipated period of suspension. Replacement of materials and additional work made necessary because of the temporary use of the highway shall be paid for at contract unit prices or as Extra Work.

All signing and barricading shall conform with the Federal Highways Administrations "Manual on Uniform Traffic Control Devices" (MUTCD) and the City of Madison Standards for sidewalk and bikeway closures and the State of Wisconsin Standard Detail Drawing S.D.D. 15d30.

The contractor shall submit an acceptable Traffic Control Plan to the office of the City Traffic Engineer, a minimum of 48 hours prior to the start of work on any project.

The contractor shall not restrict traffic during peak hours on streets with a functional classification of collector or arterial. Peak hours are defined as 7:00 a.m. to 8:30 a.m. and 4:00 p.m. to 5:30 p.m.

### **107.8 Notification When Closing Street.**

All Contractors shall give the Traffic Engineer (266-4761) notice of their intent to begin work on any street at least seventy-two (72) hours in advance. If it is necessary that a detour be used during the life of the project, then the Traffic Engineer shall have at least ninety-six (96) hours notice. Saturdays, Sundays, and legal holidays shall not be included in the measuring of notice time. Further notice shall be given of any major change in project scheduling following the original notification.

The Contractor shall not remove existing traffic control or street name signs. The Traffic Engineering Field Operations Facility (266-4767) will remove these signs within twenty-four (24) hours, (one work day), upon the Contractor's request.

In case of an emergency street closing, particularly on Saturday, Sunday or a legal holiday, then the Contractor shall notify individually, the Police Department, Fire Department and Traffic Engineer.

The Contractor shall not in any manner unnecessarily obstruct the streets or crossings, and shall at all times and under all circumstances provide safe and sufficient means for foot passengers and vehicles.

The Contractor shall not at any time close any street to the public except by express permission of the Traffic Engineer. When closing a street is provided for in the contract or when the character of the work as determined by the Engineer makes it necessary that a street or portion thereof be closed to traffic, the Contractor shall notify the Traffic Engineer at the earliest possible date so that arrangements may be made for closing the street and providing detours if possible.

### **107.9 Barricades, Warning Signs and Flagging.**

This work shall consist of furnishing, erecting and maintaining for the life of the contract, and removing at the completion of the work contemplated by the contract, traffic signs, pavement markings, barricades, lights and signals and shall include flagging and guidance of traffic. This work shall be done in accordance with the current edition of the Federal Highway Administration Part VI of the "Manual on Uniform Traffic Control Devices" (MUTCD), and the State of Wisconsin Supplementary and City of Madison Supplements. All requirements of the manual shall be a part of the contract as if attached thereto on each Public Works Project in the City of Madison. Sign sizes smaller than the standard sizes described in the manual and non-commercially manufactured signs shall not be used.

The Contractor will be held responsible for all damages to the work due to failure of barricades, signs, lights, flagpersons and watchpersons to protect it and, whenever evidence of such damage is found prior to acceptance, the Engineer may order the damaged portion immediately removed and replaced by the Contractor at the Contractor's own cost and expense if, in the Engineer's opinion, such action is justified.

## Part I - General Conditions

The Contractor shall be responsible for furnishing, erecting and maintaining those traffic control devices and facilities, as required above throughout the life of the contract, including periods of suspension, except that costs for maintaining such devices and facilities during periods of suspension not specified in the contract or the cause of which is beyond the control and without fault of the Contractor shall be paid for as Extra Work.

If, in the opinion of the Engineer, proper provisions are not provided and maintained in accordance with these Specifications, the Engineer may restrict construction operations affected by such defective signs, devices or markings until proper provisions are established and maintained, or the Engineer may take the necessary steps to place them in proper condition and may deduct the costs of such steps from monies due or to become due the Contractor.

### Bid Item 10720      Traffic Control Sign - Portable Arrow Board

#### Description.

This special provision describes providing, erecting, maintaining, moving and removing arrow board as hereinafter provided.

#### Materials.

Provide arrow board conforming to MUTCD requirements. Furnish, service, maintain, repair or replace the arrow board as necessary. Arrow board remain the contractor's property.

#### Construction.

Place arrow board at the locations indicated on the plan, in the contract, or as directed by the engineer.

#### Method of Measurement.

Traffic Control Arrow Board will be measured by the day acceptably completed. The measured quantity will equal the number of calendar days the device is in use.

#### Basis of Payment.

Payment for Traffic Control Arrow Board is full compensation for providing, installing, moving, and removing portable, self-contained flashing arrow board, including auxiliary power source.

### Bid Item 10721      Traffic Control Sign - Portable Changeable Message

#### Description.

This special provision describes furnishing, maintaining and installing portable changeable message sign as hereinafter provided.

#### Materials.

Furnish equipment that enables one person to transport and operate the sign easily without assistance.

## Part I - General Conditions

Provide a complete Changeable Message Sign and trailer that is painted highway safety orange, except the sign case, which will be painted black.

### Sign Case.

Provide a sign that is capable of displaying a minimum of three (3) lines of message text per message (frame). Each line shall consist of a minimum of eight (8) characters, equally spaced a minimum of three inches (3") and a maximum of four and one-half inches (4-1/2") apart. Characters shall be a minimum of seventeen inches (17") high and a minimum of eleven inches (11") wide and be legible from a minimum of 850 feet during both day and night conditions. The maximum sign width shall be eleven feet six inches (11'-6"). Provide a sign display that consists of either a continuous matrix of pixels or individual character modules consisting of smaller matrices of pixels. Each matrix forming a character shall consist of a minimum thirty-five (35) pixels in a five (5) horizontal pixel by seven (7) vertical pixel arrangement. Each pixel shall consist of a high-intensity LED cluster. The LED lamps shall run at a minimum voltage to provide extended life. Each pixel shall be either square in shape with a minimum of two-inch (2") sides or round in shape with a minimum two-inch (2") diameter. The driver board shall provide means for dimming. The entire sign shall complete a message change within 100 milliseconds.

Provide a sign housing that is weatherproof and is constructed of aluminum. The front face shall be covered with either a one-piece, clear, non-glare, lexan panel, or individual one-piece, clear, non-glare, lexan panels.

### Power Source.

Provide a solar Changeable Message Sign that runs on a battery system using a solar charging system.

Provide solar cells that are capable of charging and maintaining the batteries at operational levels under all weather conditions experienced in Wisconsin. A switch shall be provided to disconnect the solar power supply for safety during maintenance.

### Construction.

Install portable changeable message sign level at the locations indicated on the plan, in the contract, or as directed by the engineer.

### Method of Measurement.

Portable Electronic Changeable Message Sign will be measured per each unit complete per day.

Any day in which changeable message sign is not working properly for more than six hours will result in one day being deducted from the quantity measured for payment.

### Basis of Payment.

Payment will be for measured quantities at the contract unit price, which shall be full compensation for furnishing, maintaining, installing and/or relocating the complete unit; and for furnishing all labor, tools, equipment, services and incidentals necessary to complete the contract work.

## Part I - General Conditions

Traffic Control shall be measured for payment as a single complete unit of work, acceptably performed. The contract price shall include furnishing all materials, labor, tools, equipment and incidentals necessary to perform the work; constructing, assembling, painting, hauling, erecting, re-erecting, maintaining and removing traffic signs, barricades and other control devices; furnishing, placing, maintaining and removing lights and signals, including the fuel or power therefor; supplying and performing all flagging and guidance services; furnishing, applying and removing pavement marking, unless otherwise provided; and all other work incidental to Traffic Control. The contract lump sum shall be payable to the Contractor in accordance with the following schedule:

1. When twenty-five (25) percent or more of the original contract amount is earned, fifty (50) percent of the amount bid for Traffic Control will be paid.
2. When seventy-five (75) percent or more of the original contract amount is earned, one hundred (100) percent of the amount bid for Traffic Control will be paid.

When the contract does not include a separate contract item for Traffic Control, then all the work herein before prescribed, required and performed will not be separately measured for payment, but will be considered incidental to other items in the contract.

### Item 10725 Alternate Business Access Sign

#### General

This work consists of the construction, placement, altering and removal of alternate business access signs. The sign is used when ordinary access to properties is altered due to proposed traffic control during road construction projects. The sign directs people to the correct way to access a property due to the construction.

#### Materials

Sign shall conform to Standard Detail Drawing 6.44

#### Construction Methods

Number of signs, placement and alterations during construction shall be identified in section 107.7 MAINTENANCE OF TRAFFIC. It shall be noted that during different traffic control stages, the sign may be moved, and the arrow may be altered. Such alteration is considered incidental to this bid item.

#### Measurement

ALTERNATE BUSINESS ACCESS SIGN will be measured per each unit complete per day.

Any day in which ALTERNATE BUSINESS ACCESS SIGN is not placed properly for more than six hours will result in one day being deducted from the quantity measured for payment.

#### Payment

Payment will be for measured quantities at the contract unit price, which shall be full compensation for furnishing, maintaining, installing and/or relocating the complete unit; and for furnishing all labor, tools, equipment, services and incidentals necessary to complete the contract work.

### **107.10 Opening of Section of Highway to Traffic.**

When the contract provides that the road or portions thereof shall be closed to traffic during construction, the work shall not be opened to traffic until so directed or authorized by the Engineer. Whenever all of the work or any portion thereof is in an acceptable condition for travel, such sections shall be opened to traffic as may be directed by the Engineer, but such opening shall not be construed as assumption of the maintenance by the City unless so specifically provided, nor as acceptance of the roadway or any part of it, nor as a waiver of any of the provisions of the Specifications and contract; provided, however, that on such sections of the project as are used by traffic, the Contractor shall not be required to assume any expense entailed in maintaining that portion of the roadway used by traffic which expense is attributable to such traffic used and beyond the control of the Contractor, except costs in connection with those traffic control devices or facilities required. Such expense shall be borne by the City or shall be compensated for as Extra Work. Any damage to the highway not attributable to traffic which might occur on such sections shall be repaired by the Contractor at the Contractor's expense.

Whenever the Contractor is required to open to traffic all of the work or any portion thereof in accordance with the provisions given herein, or whenever the Contractor shall of the Contractor's own volition and when so authorized by the Engineer, open to traffic all of the work or any portion thereof prior to final acceptance, the Contractor shall conduct the remainder of the construction operations so as to cause the least obstruction to traffic.

The Contractor shall notify the Traffic Engineering Field Operations Facility in writing so that the Traffic Engineering Division can install traffic control signs and barricades prior to the opening of the street. Traffic Engineering shall have five (5) working days once the project site is restored with topsoil, seed and mulch to install signs and pavement marking. The Contractor shall maintain his/her traffic control and barricades until the Traffic Engineering Division has completed their work.

### **107.11 Use of City Water.**

When the Contractor chooses to use City of Madison water for any part of the project, then the Contractor must proceed as follows:

1. Request Water Utility to install valve on convenient hydrant.
2. Agree to pay Water Utility charges for installation, use and removal of the valve.
3. Notify Water Utility immediately when use of valve is no longer necessary.

The Contractor shall not make connections to Water Utility facilities without permission from the Water Utility.

### **107.12 Railroad-Highway Grade Separations and Approaches, New Railroad Crossings, Operations on Railroad Right-of-Way.**

#### **107.12(a) General.**

Work or operations on grade separations and their approaches, new railroad crossings, or upon railroad right-of-way shall be subject to inspection by the Chief Engineer of the railroad company,

## Part I - General Conditions

and shall be conducted and performed in a manner satisfactory to said Chief Engineer and also the City Engineer.

All work or operations incident thereto within the right-of-way of the railroad company shall be conducted in a manner which will not interfere with the safe and uninterrupted operation of railroad traffic.

Unless otherwise provided in the contract, flagging protection shall be required in conjunction with the construction:

1. Whenever construction operations or materials will or may encroach upon the minimum allowable statutory clearance from any track or tracks, including pile driving, the placing or removal of falsework, bracing, cofferdams, sheeting, or forms and the construction of permanent structure over or adjacent to a track;
2. When trucks or machinery will be operated closely along or over tracks or where cranes will be handling materials or equipment over or across any track;
3. When construction operations are in the close vicinity of power lines, railroad signal and communication lines, underground cables, fuel oil facilities or pipe lines which might result in fire or damage to such facilities to endanger railroad operations, or to endanger the public in the transaction of business on railroad premises;
4. When excavation, tunneling, blasting, pile driving, placing or removing cofferdams or sheeting, or similar activities might cause the railroad's tracks or buildings to be undermined, heaved out of normal level or shifted out of alignment, etc.;
5. At any other time when in the judgment of the Railroad's Superintendent or Division Engineer there is a reasonable probability of accident hazard to railroad traffic and at any other time when the flagging protection is necessary for safety to comply with the Operating Rules of the railroad.

Minimum allowable clearances from tracks during construction shall be not less than twelve (12) feet horizontally from the center line of any track nor less than twenty-two (22) feet vertically above top of rail, except as specifically approved by the Chief Engineer or a duly authorized representative.

The Railroad Company may require the Contractor to provide temporary telltale protection, as may be required under Section 192.31, Wisconsin Statutes, for any construction encroachment over railroad trackage of less than twenty-two (22) feet.

The Contractor shall be informed of the rules and regulations of the railroad company with respect to operations on the railroad right-of-way and shall arrange with the railroad company for the services of such qualified railroad employees as the Chief Engineer of the railroad company may prescribe for the protection of railroad traffic through the work. The cost of such services shall be borne by the Contractor, and the Contractor shall make payment directly to the railroad company.

The Contractor shall notify the Chief Engineer of the railroad company in writing, at least seventy-two (72) hours before starting any work in the proximity of the tracks, setting forth specifically the time at which it is planned to start such operations.

## Part I - General Conditions

Excavations in the proximity of the tracks shall be protected in accordance with plan details.

The track zone shall be kept clear of any loose material or debris at all times.

Arrangements for crossing the tracks of a railroad company at locations other than at existing public crossings shall be made by the Contractor and the Contractor shall bear all costs incident thereto.

A written release from the railroad company notifying the Engineer that all claims against the Contractor for costs incurred by the railroad company have been satisfied shall be furnished, when required, before final payment for the contract work will be made.

### 107.12(b) Work by Railroad.

The railroad company may undertake certain work or operations incident to the project which are the subject of an agreement between the City and the railroad company. The Contractor shall make no alterations of such work without the consent of the Chief Engineer of the railroad company and then only in a manner as prescribed by the Chief Engineer. Should the Chief Engineer elect to have alterations requested by the Contractor made with railroad company forces, the Contractor shall bear the cost thereof and make payment therefor direct to the railroad company.

The movement or adjustment of telegraph, telephone, or signal facilities owned, operated or maintained by the railroad company and not otherwise provided for on the plans or special provisions or in agreements between the City and the company shall be at the cost and expense of the City.

### 107.12(c) Railroad Insurance Requirements.

The Contractor shall provide such special third party protection insurance for and in behalf of the railroad company and operating railroad for each crossing. The Contractor shall furnish evidence to the Engineer that the insurance coverages have been provided by filing two (2) copies of the policy extending such protection at the time of filing of other contract documents. One copy of this insurance policy will be transmitted by the City to the railroad company.

The minimum amount of insurance to be provided shall be limited to a combined single limit amount of Two Million Dollars (\$2,000,000) per occurrence for Bodily Injury Liability, Property Damage Liability, and Physical Damage to Property, with Six Million Dollars (\$6,000,000) aggregate for the term of the policy with respect to Bodily Injury, Liability, Property Damage Liability and Physical Damage to Property.

The coverage provided by this insurance shall be primary insurance exclusive of any carried by the named insured, and this coverage will be exhausted first, notwithstanding the fact that the insured may have other valid and collectible insurance covering the same risk.

No work which will require entry upon the right-of-way or premises of the railroad company shall be undertaken until the required insurance policy in acceptable form has been filed with and acknowledged in writing by the City. Such insurance shall be carried until all work required to be performed upon the right-of-way or premises of the railroad company shall have been satisfactorily completed and formally accepted by the City.



The cost of providing third party protection for the railroad company shall be construed to be incidental to other items of the contract and no additional payment will be made therefor unless a bid item for Railroad Insurance is included in the contract.

#### 107.12(d) Flagging Protection

It shall be the responsibility of the Contractor to compensate the Railroad for the flag person requirements and shall be considered incidental to the City contract. Prior to any work within twenty-five feet (25') of the Railroad Tracks, the Contractor shall provide to the operating railroad an estimate of the time required to perform the necessary work within twenty-five feet (25') of the Railroad Tracks and the Contractor shall pre-pay the operating railroad an estimated cost for compensation for a flag person based on the estimated time required to perform all work within twenty-five feet (25') of the tracks and the current hourly rate of compensation charged by the operating railroad for a flag person.

Absolutely no staging of equipment or materials will be allowed within the railroad right-of-way.

If a Contractor violates any of these requirements, the operating railroad reserves the right to remove and prohibit the Contractor from any further access or encroachment on the railroad right of way regardless of whether or not that access or encroachment is on, under, over, intentional or inadvertent, until such time as the Contractor provides satisfactory assurances and measures to prevent any reoccurrence of such violation.

#### **107.13 Tree Protection Specifications.**

These specifications shall be applicable to all Contractors working in the Public Right of Way, whether by permit, Public Works Contract, Developer Agreement or any other permission to work within the Public Right of Way. However, any Contractor doing work related to an emergency situation as described in Sections 10.05(13)(a) and 10.101(5) of the Madison General Ordinances are not bound by these provisions for those situations only. The term "Contractor" shall also mean 'Permit Grantee' or anyone given permission to work in the Public Right of Way, regardless of whether a permit is obtained or granted. For the purposes of these specifications, "Public Right of Way" shall include any property that the City of Madison has an ownership interest in, including, without limitation, highways and highway right-of-ways, public walkways and bike paths, parks, greenways and stormwater management areas. Other Sections of the Standard Specifications may repeat portions of this specification for emphasis and / or expand upon these specifications. The specifications found in those other Sections are not intended to conflict with these specifications.

The maintenance and enhancement of the urban forest is a goal of the City of Madison. Preserving and protecting healthy trees is one objective towards achieving this goal. Trees vary in their ability to adapt to altered growing conditions. Mature trees have established systems in the pre-existing physical environment. Disruption of this environment by construction activities interrupts the tree's physiological processes causing depletion of energy reserves and a decline in vigor, often resulting in the tree's death. These tree protection specifications are intended to insure that appropriate practices will be implemented in the construction phase of the project to protect a tree's structural integrity and future health. Also, these specifications will reduce the likelihood of undesirable consequences that may result from uninformed or careless construction practices adjacent to trees. The three most common forms of construction damage to trees are:

- Root cutting

## Part I - General Conditions

- Bark abrasions
- Soil compaction

Damage can be prevented or minimized by following the specifications below and properly educating construction staff of these specifications and use of care when working around trees during the construction process. If the City Forester or City Engineer determines that a tree has been damaged due to failure to follow these specifications, or negligence of the Contractor or Subcontractor, a fine or liquidated damages shall be assessed to the Contractor or permit holder.

In particularly sensitive areas or areas of dense tree cover, the City Engineer may elect to specify the use of a protective fencing to mark the tree protection zones or zones of no disturbance. Whenever construction fencing is used, a bid item shall be included in the contract, unless specified as incidental.

### 107.13(a) Underground Utility Excavation & Installation.

The Contractor shall not grade, excavate, or otherwise disturb the area within five (5) feet of any tree as measured from the outside edge of the tree trunk or visible aboveground portion of the root system along the length of the terrace, without prior permission from the City Forestry Representative.

For laterals or utilities that are in close proximity to terrace trees, the situation shall be reviewed on a case by case basis by the Engineer and City Forestry Representative. The contractor shall use construction methods to minimize tree damage as directed by the Engineer. The Engineer may elect to terminate lateral installation prior to conflict with tree (normally terminate at the curb). Most laterals shall have their locations verified and on the plan set in advance of bidding. Laterals that have not had their locations verified, shall be so noted on the plans.

Boring under or within the 5 foot protection zone may be allowable.

All roots over one (1) inch in diameter that are damaged shall be cleanly cut immediately in back of the damaged section on the same day of the excavation. Cuts may be made with lopping shears, chainsaw, stump grinder, or other means which will produce a clean cut. Exposed roots should be covered as soon as excavation and installation are complete.

The Contractor shall not rip or pull roots out towards the trunk of a tree while excavating with a backhoe. The use of a backhoe to cut roots is NOT acceptable.

### 107.13(b) Curb Excavation and Installation.

Root masses that grow very close to, up to or over curb will require extra care during excavation. Curb modifications may be necessary as determined by the Engineer, such as curving into the direction of the street to avoid damage to the root system.

All roots over one (1) inch in diameter that are damaged shall be cleanly cut immediately back of the damaged section on the same day of the excavation. Cuts may be made with lopping shears, chainsaw, stump grinder, or other means which will produce a clean cut. Exposed roots should be covered as soon as excavation and installation are complete.

The City Forester will review curb and gutter that is marked for removal and adjacent to street trees. Forestry will mark curb and gutter with "NRC" (No Root Cutting) next to trees that curb and gutter

## Part I - General Conditions

removal and replacement has a greater potential to damage tree roots. The Contractor shall proceed in the following sequence to repair sidewalk marked with NRC as follows:

1. Place a yellow ribbon around the tree marked NRC at approximately 4-feet from the ground in order to highlight these trees for the equipment operator removing the concrete;
2. Ribbon shall remain until forms have been removed;
3. Carefully remove the concrete curb and gutter so marked and those adjacent curb and gutter sections six (6) feet on either side of the visible root flair without excavating into the terrace or without damaging roots;
4. At the City's discretion, install a type II barricade with a sign provided by the City of Madison that states, "Tree Roots are being evaluated by City Forester";
5. Await inspection by Forester, who shall determine which roots can or cannot be cut or shaved, how much excavation can be safely allowed and communicate his/her findings to the Contractor and the Engineering Construction Inspector. After the Contractor notifies the City Forestry staff that the removals are complete and ready for their determination, the City Forestry staff shall respond by the end of the following work day. Rain days, weekends and holidays do not count as a work day for this purpose.
6. Proceed to cut or shave roots in the presence and under the direction of the Forester.

At locations where the curb and gutter is to be removed and replaced that are adjacent to street trees that are not marked "NRC", the Contractor can remove the concrete and underlying soil to sub-grade without notification to the City Forestry Representative.

Curb excavations shall be limited to one (1) foot behind the proposed curb for trees less than 10" in DBH (Diameter at Breast Height), for a distance of ten (10) feet each way from a tree trunk to reduce damage to the root system.

Curb excavations shall be limited to six (6) inches behind proposed curb for trees greater than 10" DBH, or street terrace widths less than six (6) feet for a distance of ten (10) feet each way from a tree trunk to reduce damage to the root system.

When excavation behind the curb is limited to less than 6 inches, the new curb must be a 'hand-formed' replacement for a minimum length as directed by the engineer.

Contractor shall not cut any roots that are 3" or larger in diameter without prior permission from the City Forestry Representative for curb and gutter installation.

In situations where root severing has to occur, the root cutting will be clean cuts – not jagged or ripped. The use of a Backhoe to cut tree roots is NOT acceptable.

All roots over one (1) inch in diameter that are damaged shall be cleanly cut immediately back of the damaged section on the same day of the excavation. Cuts may be made with lopping shears, chainsaw, stump grinder, or other means which will produce a clean cut. Exposed roots should be covered as soon as excavation and installation are complete.

107.13(c) Sidewalk Excavation and Installation.

The City Forester will review sidewalk that is marked for removal and adjacent to street trees. Forestry will mark sidewalk with “NRC” (No Root Cutting) next to trees that sidewalk removal and replacement has a greater potential to damage tree roots. The Contractor shall proceed in the following sequence to repair sidewalk marked with NRC as follows:

1. Place a yellow ribbon around the tree marked NRC at approximately 4-feet from the ground in order to highlight these trees for the equipment operator removing the concrete;
2. Ribbon shall remain until forms have been removed;
3. Carefully remove the concrete sidewalk so marked and those adjacent sidewalk sections six (6) feet on either side of the visible root flair without damaging roots;
4. At the City’s discretion, install a type II barricade with a sign provided by the City of Madison that states, “Tree Roots are being evaluated by City Forester”;
5. Await inspection by Forester, who shall determine which roots can or cannot be cut or shaved and communicate his/her findings to the Contractor and the Engineering Construction Inspector. After the Contractor notifies the City Forestry staff that the removals are complete and ready for their determination, the City Forestry staff shall respond by then end of next work day. Rain days, weekends and holidays do not count as a work day for this purpose.
6. Proceed to cut or shave roots in the presence and under the direction of the Forester;
7. Install the granular sub-base, 3-inch minimum depth if the sub-grade is not acceptable, and new concrete sidewalk, 5-inch minimum depth;
8. Remove ribbon.

At locations where the sidewalk is to be removed and replaced that are adjacent to street trees that are not marked “NRC”, the Contractor can remove the concrete and underlying soil to sub-grade without notification to the City Forestry Representative. The Contractor and the City shall review the construction site for privately owned trees (on private property, but near the sidewalk to be removed) that could require the above process. In those cases, the trees shall be reviewed on a case-by-case basis with the property owner.

Contractor shall not cut any roots that are 3” or larger in diameter without prior permission from the City Forestry Representative for sidewalk installation or repair within five (5) feet of any tree located in the terrace as measured from the outside edge of the tree trunk or visible aboveground portion of the root system. In situations where root severing has to occur, the root cutting will be clean cuts – not jagged or ripped. The use of a Backhoe to cut tree roots is NOT acceptable. All roots over one (1) inch in diameter that are damaged shall be cleanly cut immediately back of the damaged section on the same day of excavation. Exposed roots should be covered as soon as excavation and installation are complete.

107.13(d) Root Cutting / Root Grinding.

Roots shall be cut or ground as specified by the City Forestry Representative. This cutting or grinding shall require the use of tools such as: stump grinders; lopping shears; root saws; front mounted stump or wheel grinders; and chainsaws. Unless otherwise specified the Contractor shall be paid per linear foot for Root Cutting for the length of the NRC Curb or NRC sidewalk, with a maximum length of fifteen (15) linear feet per NRC location, more specifically as follows:

Root Cutting – Curb & Gutter

Description

This item shall include all root cutting and / or root grinding as determined by the City Forestry Representative for roots under removed curb & gutter that has been marked with “NRC” for No Root Cut until further inspection. Work under this item shall include all work, materials, labor and incidentals necessary to cut or grind the root, using proper tools as prescribed by the City Forestry Representative.

Method of Measurement

Root Cutting – Curb & Gutter shall be measured per linear foot of curb & gutter that is marked with “NRC” in the field, with a maximum measurement of 15 linear feet per tree location.

Basis of Payment

Root Cutting – Curb & Gutter shall be measured as described above which shall be full compensation for all work, materials and incidentals to complete the work as described above regardless of the degree of difficulty per given location.

Root Cutting – Sidewalk

Description

This item shall include all root cutting and / or root grinding as determined by the City Forestry Representative for roots under removed sidewalk that has been marked with “NRC” for No Root Cut until further inspection. Work under this item shall include all work, materials, labor and incidentals necessary to cut or grind the root, using proper tools as prescribed by the City Forestry Representative.

Method of Measurement

Root Cutting – Sidewalk shall be measured per linear foot of sidewalk that is marked with “NRC” in the field, with a maximum measurement of 15 linear feet per tree location.

Basis of Payment

Root Cutting – Sidewalk shall be measured as described above which shall be full compensation for all work, materials and incidentals to complete the work as described above regardless of the degree of difficulty per given location.

107.13(e) Terrace Restoration.

All mechanical grading, including sod installation within five (5) feet of any tree as measured from the outside edge of the tree trunk or visible aboveground portion of the root system shall be prohibited. Any grading required within the root protection zone shall be done with hand implements and performed in a manner so as to minimize damage to the root system.

107.13(f) Bark Abrasions and Limb Damage.

Contractor shall take precautions during construction not to disfigure, scar, or impair the health of any tree on public or private property.

Pre-construction pruning – Trees larger than 10” DBH will be pruned by City Forestry to an approximate minimum height of fourteen (14) feet above the road wherever construction equipment is expected to invade the tree crown. All pruning shall be done according to ANSI A300 tree pruning specifications. Occasionally a limb may have to remain at a height less than fourteen (14) feet above the roadway. These instances shall be noted during the ‘walk thru’ and the Contractor shall employ methods to protect said limb.

Contractor shall operate equipment in a manner as to not damage the branches of a tree. This may require using smaller equipment and loading or unloading materials in a designated space away from trees on the construction site.

Contractor shall notify City Forestry the same day of any damage to trees resulting from construction activities.

107.13(g) Soil Compaction.

No equipment or materials will be allowed to be parked on, driven over, or be piled on areas within five (5) feet a tree as measured from the outside edge of the tree trunk or visible aboveground portion of the root system. This not only prevents compaction, but also prevents damage to the trunks of trees and branches through scraping of scuffing the bark.

107.13(h) Contractor / Foreperson Acknowledgement.

The Tree Protection Specification and known conflicts and concerns shall be reviewed at the Pre-Construction meeting with the Contractor. This review shall include review of a one page educational informational sheet that details the procedures for avoiding damage to the tree and tree roots.

Utilities or others working in the Public Right of Way shall be required to sign this acknowledgement on a case by case basis.

107.13(i) Cost Recovery Charges and Liquidated Damages.

The Contractor’s failure to follow the proper safeguards of these specifications shall result in the following cost recovery charges and liquidated damages to be assessed against the Contractor:

Where construction damage occurs causing or resulting in removal of the tree of 3 inch diameter or less (as measured at 12 inches above the ground):

1. The costs associated with removing the tree including wood disposal.

Part I - General Conditions

2. The costs associated with removing the stump to a depth of at least 24 inches below the ground.
3. The costs associated with replanting a replacement tree that is balled & burlapped and shall have a minimum caliper of two (2) inches. The species and replanting location shall be determined by City Forestry.

Where construction damage occurs causing or resulting in removal of the tree of greater than 3 inch diameter (as measured at 12 inches above the ground):

1. The costs associated with removing the tree including wood disposal.
2. The costs associated with removing the stump to a depth of at least 24 inches below the ground.
3. The costs associated with replanting a replacement tree that is balled & burlapped and shall have a minimum caliper of two (2) inches. The species and replanting location shall be determined by City Forestry.
4. The value of the existing tree which shall equal \$125.00 per trunk diameter inch, as measured at 12 inches above the ground.

For bark scraping and broken branches:

1. The costs associated with pruning broken branches, including wood disposal.
2. Loss of limb or broken branch larger than three (3) inches in diameter: \$150.00 for each occurrence. Breakage of limbs that are less than fourteen (14) feet above the roadway shall be reviewed on a case by case basis.
3. Damage to trunk or bark larger than one-half (1/2) square foot in area: \$400.00 each area.

For root cutting or excavation within the root protection zone:

1. For mechanical excavation within five (5) feet of a tree as measured from the outside edge of the tree trunk or visible aboveground portion of the root system, along the length of the terrace or sidewalk side of the tree, including ripping of roots back towards the trunk, without prior permission from City Forestry Representative: \$150.00 for each occurrence
2. For mechanical excavation beyond six (6) inches or one (1) foot of the proposed curb installation, as determined by the size of existing tree and terrace width, including ripping of roots back towards the trunk: \$150.00 for each occurrence (see Curb excavation and installation specifications)
3. For failure to cleanly cut damaged roots greater than one (1) inch on the same day as the excavation: \$150.00 for each occurrence.

For Public Works Contracts these charges and liquidated damages shall be assessed as Liquidated Damages. For Private Contracts, Permit work, or others, these charges and liquidated damages shall be assessed as City imposed forfeitures or private contract forfeitures.

107.13(j) Private Development, Tree Removal.

If a private development shall require the removal of a public street tree to facilitate the construction of a site, adding a driveway, installing underground utilities, or any other improvement or site revision, the Developer shall obtain approval from City Forestry in advance of the proposed work.

**107.14 Weapons Prohibition**

Contractor shall prohibit, and shall require its subcontractors to prohibit, its employees from carrying weapons, including concealed weapons, in the course of performance of work under this Contract, other than while at the Contractor's or subcontractor's own business premises. This requirement shall apply to vehicles used at any City work site and vehicles used to perform any work under this Contract, except vehicles that are an employee's "own motor vehicle" pursuant to Wis. Stat. sec. 175.60(15m).



## **ARTICLE 108 - LEGAL RELATIONS**

---

### **108.1 Laws to be Observed.**

The Contractor shall at all times observe and comply with all Federal and State laws and administrative rules, local laws, ordinances, and regulations which in any manner affect the conduct of the work, and all orders or decrees, as exist at the present or which may be enacted later, of bodies or tribunals having jurisdiction or authority over the work. No plea of misunderstanding or ignorance thereof will be considered. The Contractor shall indemnify, defend and save harmless the City and all of its officers, officials, agents, employees and servants against any claim or liability arising from or based on the violation of any such law, ordinance, regulation, order or decree, whether by the Contractor or the Contractor's employees, subcontractors or agents.

The movement of vehicles or equipment over any public highway to the project, necessary for the prosecution of the work shall be regulated in accordance with the provisions of the Wisconsin Statutes and the Madison General Ordinances.

### **108.2 Permits and Licensing.**

The City of Madison will submit a DNR Notice of Intent (NOI) to obtain coverage under the Construction Site General Permit No. WI-S067831-2 for construction site erosion control on City of Madison Public Works contracts with one acre or greater of land disturbing activity. The Contractor shall meet the conditions of the permit by properly installing and maintaining the erosion control measures shown on the plans, specified in the Special Provisions, or as directed by the Engineer. This work will be paid for under the appropriate contract bid items in accordance with Article 210 EROSION CONTROL. A copy of the permit will be available at the City of Madison, Engineering Division office.

This list is not intended to be an exhaustive list of all permits that may be required to be obtained by the Contractor for construction. It shall be the responsibility of the Contractor to identify and obtain all other permits and licenses, pay all charges and fees, and give all notices necessary and incident to the due and lawful prosecution of the work.

### **108.3 Patented Devices, Materials and Processes.**

Unless otherwise specified, contract prices are to include all royalties and costs arising from patents, trademarks, and copyrights in any way involved in the work. It is the intent that whenever the Contractor is required or desires to use any design, device, material or process covered by letters patent or copyright, the right for such use shall be provided for by suitable legal agreement with the patentee or owners and a copy of this agreement shall be filed with the Engineer; however, whether or not such agreement is made or filed as noted, the Contractor and the surety in all cases shall indemnify and save harmless the City from any and all claims for infringement by reason of the use of any such patented design, device, material or process to be involved under the contract, and shall indemnify the City for any costs, expenses, and damages which it may be obliged to pay, by reason of any such infringement, at any time during the prosecution or after the completion of the work.

### **108.4 Safety, Health and Sanitation.**

The Contractor shall comply with all Federal, State and local laws governing safety, health and sanitation. The Contractor shall also provide all safeguards, safety devices and protective equipment,

and take any other actions necessary to protect the life and health of employees on the job and the safety of the public and to protect property in connection with the performance of the work covered by the contract.

**108.5 Personal Liability of Public Officials.**

In carrying out any of the provisions of this contract or in exercising any power or authority granted to them thereby, there shall be no personal liability upon the City, its officers, officials, agents and employees, it being understood that in such matters they act as agents and representatives of the City. Any right of action by the Contractor against the City, or its officers, officials, agents or employees, is hereby expressly waived.

**108.6 No Waiver of Legal Rights.**

The City shall not be precluded or estopped by any measurement, estimate, or certificate made either before or after the completion and acceptance of the work and payment therefor, from showing the true amount and character of the work performed and materials furnished by the Contractor, or from showing that any such measurement, estimate or certificate is untrue or incorrectly made, or that the work or materials do not conform in fact to the contract. The City shall not be precluded or estopped, notwithstanding any such measurement, estimate, or certificate and payment in accordance therewith, from recovering from the Contractor and the Contractor's sureties such damages as it may sustain by reason of the Contractor's failure to comply with the terms of the contract. Neither the acceptance by the Engineer nor any payment for or acceptance of the whole or any part of the work, nor any extension of time, nor any possession taken by the City, shall operate as a waiver of any portion of the contract, or of any power herein reserved, or any right to damages herein provided. A waiver of any other or subsequent breach of the contract shall not be held to be a waiver of any other or subsequent breach.

## **ARTICLE 109 - PROSECUTION AND PROGRESS**

---

### **109.1 Subletting or Assignment of Contract.**

The Contractor shall not sublet, sell, transfer, assign, or otherwise dispose of the contract or any portion thereof, or any right, title, or interest therein, without written consent of the Engineer.

Consent to sublet any portion of the contract shall not be construed to relieve the Contractor of any responsibility for the fulfillment of the contract or to release the Contractor or the Contractor's surety of liability under the contract and bond.

The Contractor shall, at the time of the signature of the contract, notify the Engineer of the names of subcontractors proposed for the work and shall not employ any that the Engineer may within ten (10) days object to as unsatisfactory. The Contractor shall not change subcontractors without written approval of the Engineer.

Requests for permission to sublet any portion of the contract shall be in writing and accompanied by a showing that the organization which will perform the work is particularly experienced and equipped for such work.

The Contractor shall be fully responsible to the City for the acts and omissions of subcontractors and of persons and organizations either directly or indirectly employed by the Contractor.

Nothing contained in the contract documents shall create any contractual relation between any subcontractor and the City.

All work performed for the Contractor by a subcontractor will be pursuant to an appropriate written agreement between the Contractor and subcontractor which specifically binds the subcontractor to the applicable terms and conditions of the contract documents for the benefit of the City. Such agreement shall be available for review upon demand of the Engineer.

The Contractor shall not sublet over forty (40) percent of the total contract amount without written consent of the Board of Public Works.

### **109.2 Prosecution of the Work.**

The Contractor shall begin the work within seven (7) days after the date of written notice to proceed.

Definite notice of intention to start work shall be given to the Engineer at least seventy-two (72) hours in advance of beginning work.

The Contractor shall employ an ample labor and supervisory force and provide construction equipment properly adapted to the work and of sufficient capacity and efficiency to accomplish the work in a safe and workmanlike manner at the rate of progress specified. All equipment shall be maintained in good working order and provision shall be made for immediate emergency repairs.

Should the Contractor fail to maintain the rate of progress required to complete the work within the contract time specified, the Engineer may require that additional labor or equipment be placed on the work, or a reorganization be effected in order that the work will be brought up to schedule and

maintained there. Should the Contractor fail to comply therewith, the Engineer may proceed under the provisions of these Specifications.

In the event work is prosecuted during adverse weather conditions, the Contractor will be required to exercise such precautions necessary to produce satisfactory work, and shall protect the finished work from the elements. It is agreed and understood that the cost thereof has been included in the unit prices bid for the various items of work in the contract and that no extra compensation will be allowed therefore.

If it is desirable to begin work before the above mentioned date, the Contractor shall establish a mutually acceptable date with the City Engineer. The Contractor shall limit work hours to 7:00 a.m. to 7 p.m. Monday-Saturday unless approved by the Engineer in writing.

### **109.3 Limitations of Operations.**

At any time when, in the judgment of the Engineer, the Contractor has obstructed or closed, or is carrying on operations on a greater portion of the road than is necessary for the proper prosecution of the work, the Engineer may require the Contractor to finish the sections on which work is in progress before work is started on any additional section.

### **109.4 Character of Workers.**

The Contractor shall, at all times, enforce strict discipline and good order among personnel, subcontractors and others employed on the work, and shall not employ on the work any unfit person or anyone not skilled in the work assigned.

All supervisors and workers shall have sufficient skill and experience to properly perform the work assigned to them. Workers engaged in special work or skilled work shall have sufficient experience in such work and in the operation of the equipment and tools required to perform all work properly and satisfactorily.

If any person employed on the work shall refuse or neglect to obey the directions of the Engineer, as to quality of work, character of the work or quality of materials, or be so incompetent or disorderly as to endanger the proper fulfillment of this contract, such person shall, upon the written order of said Engineer, be at once removed from the project and not again employed on any part of the work.

Should the Contractor fail to remove such person or persons as required above, or fail to furnish suitable and sufficient personnel for the proper prosecution of the work, the Engineer may withhold all estimates which are or may become due, or the Engineer may suspend the work by written notice until such orders are complied with.

### **109.5 Methods and Equipment.**

The Contractor shall provide and furnish the machinery, equipment and tools necessary to perform the work. These shall be in such condition and of such capacity as will produce work of satisfactory quality and complete the work within the contract time.

Equipment shall be such that no injury to the roadway, pavement, structures, adjacent property, or other highways will result from its use, and it shall conform to the requirements set forth in detail under specific items or classes of work.

The Contractor shall not operate vehicles or equipment over the subgrade, base course, or pavement which may cause damage to the subgrade, base course or pavement. This restriction applies not only to the type of vehicles or equipment but also to the gross weights and loads of the vehicles or equipment.

Before any personnel of the Contractor enter any access structure, catchbasin, or similar structure regardless of the location, it shall be tested for toxic and combustible gases and for oxygen deficiency with a detector provided by the Contractor. When any of the above conditions exist in a structure tested, that structure shall be completely vented and then retested until proven safe for entry and be continuously tested during the entire time personnel is within that structure. All cost of testing shall be considered incidental to the contract.

Failure on the part of the Contractor to provide adequate equipment, maintained in proper working order, may be sufficient cause for suspension of specific operations until compliance is attained or may constitute cause for default of contract.

When the methods and equipment to be used by the Contractor in accomplishing the construction are not prescribed in the contract, the Contractor is free to use any methods or equipment that will accomplish the contract work in conformity with the requirements of the contract.

When the contract specifies that the construction be performed by the use of certain methods and equipment, such methods and equipment shall be used unless others are authorized by the Engineer. If the Contractor desires to use a method or type of equipment other than those specified in the contract, the Contractor may request authority from the Engineer to do so. The request shall be in writing and shall include a full description of the methods and equipment proposed to be used and an explanation of the reasons for desiring to make the change. If approval is given, it will be on the condition that the Contractor will be fully responsible for producing construction work in conformity with contract requirements. If, after trial use of the substituted methods or equipment, the Engineer determines that the work produced does not meet contract requirements, the Contractor shall discontinue the use of the substitute method or equipment and shall complete the remaining construction with the specified methods and equipment. The Contractor shall remove the deficient work and replace it with work of specified quality, or take such other corrective action as the Engineer may direct. No change will be made in basis of payment for the construction items involved nor in contract time as result of authorizing a change in methods or equipment under these provisions.

#### **109.6 Suspension of the Work.**

The Engineer shall have the authority to order the partial or complete suspension of operations for such period or periods as the Engineer may deem necessary:

1. In the interest of public safety and convenience, or
2. Due to unsuitable weather and such other conditions as are considered unfavorable for prosecution of satisfactory work, or
3. Due to the failure on the part of the Contractor to carry out orders given or to perform any or all of the provisions of the contract.

Orders to suspend work shall be in writing. Unless specifically provided in the notice to suspend work, no additional or extra compensation or additional contract time will be allowed due to such suspension of operations. The Contractor may seek review of any suspension order not providing for additional compensation pursuant to Section 105.2 of these Specifications.

The Contractor shall resume work on the project no later than the date fixed in the written notice from the City to the Contractor to resume work.

### **109.7 Time of Completion.**

The time of completion of the work contemplated under the contract will be specified in the agreement in one of the following ways:

1. A specific number of work days.
2. A specific number of calendar days including Saturdays, Sundays, and holidays.
3. A given calendar date on or before which the work shall be completed.

Work shall be prosecuted effectively and diligently to completion. Failure to begin operations, or failure to diligently prosecute the work, may be considered as a breach of contract and render the Contractor liable to action under default of contract, or the revocation or suspension of the Contractor's privilege to bid additional work, or both.

It is understood that the rate of progress and the completion of the work within the time as specified is an essential part of the contract.

The contract starting date, for purposes of determining contract time and extensions, is the seventh (7) day following the date of notification to begin work.

Contract time will not be charged during periods of complete suspension of operations, when approved by the City in conjunction with an order by the Engineer suspending operations or when so provided in the special provisions.

No work day will be charged on a project when the Contractor does incidental work during such times as the Engineer deems that significant work on the project cannot be accomplished. This paragraph is not applicable to fixed completion date contracts.

No project shall be deemed complete or accepted until all excess mud, terrace dirt, asphalt material, rocks and crushed stone have been removed from the sidewalk, terrace, gutter and pavement. Work days may be charged against the Contractor until all such cleanup is complete to the satisfaction of the Engineer.

Contract time will be extended in an amount as is mutually agreed upon by the Engineer and the Contractor, on the basis of contract change orders involving alterations in the contract affecting the prosecution of work, or involving extra or additional work, when such alterations are necessary for the purposes or convenience of the City when such extra additional work is of such character or is ordered to be done at such a time that the amount of time reasonably necessary to perform such work is disproportionate to the contract time originally set up in the proposal. The agreement for extended time on this account shall be arrived at concurrently with and as a part of the consideration for the

specific alteration or extra or additional work covered by that order. In the event no specific mention thereof is made in such order the value of the extra or additional work will be included in the computation for extension or contract time for increased value of work as hereinafter set forth.

In the event that the money value of work completed, exclusive of such extra or additional work for which additional time had been agreed upon as herein before set forth, is in excess of the amount of the original contract, the contract time will be extended proportionately in an amount, computed to the nearest whole day, in the ratio that the final cost of the work exclusive of the final cost of such extra or additional work for which additional time had been agreed upon as previously set forth, bears to the total amount of the original contract. When a contract completion date is stipulated, the equivalent contract time for this purpose will be construed as the total elapsed calendar days between the contract starting date and the contract completion date.

Permitting the Contractor to continue and finish the work or any part of it after the time fixed for its completion, or after the date to which the time for completion may have extended, shall in no way operate as a waiver on the part of the City of Madison of any of its rights under the contract.

In the event that a Contractor, in one letting, should be awarded two or more projects of a similar nature, then the letters of notification for each similar project shall be sent to the Contractor to begin work, at consecutive fourteen (14) day intervals. The City reserves the right to vary this schedule because of time of year or other circumstances that may affect a specific project.

#### **109.8 Delays and Extensions of Time.**

Should the Contractor find it impossible to complete the work on or before the time for completion as specified in the contract, the Contractor may, at any time prior to the expiration of the time stipulated for completion, make a written request to the Board of Public Works for an extension of time, setting forth therein the reasons which the Contractor believes will justify the granting of the request. If the Board of Public Works finds that the work was delayed because of conditions beyond the control of the Contractor, it may grant an extension of time for completion in such amount as it finds to be warranted and justified.

If the Contractor is delayed at any time in the progress of the work by any act of the City, or by any other Contractor employed by the City, or by any changes ordered in the work, or by strikes, lockouts, fire, unusual delay in transportation, unavoidable casualties or any causes beyond the Contractor's control, or by any causes for which the Engineer may justify the delay, then the time of completion shall be extended for such reasonable times as the Board of Public Works may decide, provided the Contractor provides written notice of the cause of delay within ten (10) days after it first occurs.

If no schedule or agreement is made stating the dates upon which drawings shall be furnished to the Contractor, then no claim for delay shall be allowed for the City's failure to furnish drawings until two (2) weeks after demand for such drawings and not then unless such claims be reasonable.

#### **109.9 Liquidated Damages.**

Should the Contractor fail to complete the work within the time specified in the contract, or within such extra time as may have been allowed by extensions, there shall be deducted from any monies due or that may become due the Contractor, or in the event no monies are due, the Contractor shall pay to the City, the sum set forth in the following schedule for each and every day that the work shall

remain uncompleted. This sum shall be considered and treated not as a penalty but as fixed, agreed and liquidated damages due the City from the Contractor by reason of inconvenience to the public, added cost of engineering and supervision, maintenance of detours and other items which have caused an expenditure of public funds resulting from the Contractor's failure to complete the work within the time specified in the contract.

The fixed, agreed and liquidated damages shall be assessed, unless otherwise specified, in accordance with the following schedule, which represents the City's estimate of damages at the time of contracting:

<b>Contract Amount</b>			
<b>Contract Amount</b>		<b>Daily Charge</b>	
<b>From More Than</b>	<b>To and Including</b>	<b>Calendar Day</b>	<b>Working Day</b>
\$0	\$50,000	\$200.00	\$350.00
50,000	100,000	375.00	750.00
100,000	300,000	480.00	960.00
300,000	500,000	670.00	1340.00
500,000	1,000,000	855.00	1710.00
1,000,000	--	1155.00	2310.00

**109.10 Default on Contract.**

If in the opinion of the Engineer the Contractor:

1. Fails to begin the work under the contract within the time specified; or
2. Fails to perform the work with sufficient workers and equipment or with sufficient materials to insure the completion of said work within the specified time; or
3. Performs the work unsuitably or neglects or refuses to remove materials or to perform anew such work as shall be rejected as defective and unsuitable; or
4. Discontinues the prosecution of the work; or
5. Fails to resume work which has been discontinued within a reasonable time after notice to do so; or
6. Becomes insolvent or is declared bankrupt, or commits any act of bankruptcy or insolvency; or
7. Allows any final judgment to stand against the Contractor unsatisfied for a period of forty-eight (48) hours; or
9. Makes an assignment for the benefit of creditors; or
10. Is determined to be in violation of the provisions of the contract relative to hours of labor, wages, character and classification of workers employed; or



## Part I - General Conditions

11. Fails to maintain insurance coverage as required; or
12. For any other cause whatsoever fails to carry on the work in an acceptable manner,

then the Engineer shall give notice in writing to the Contractor and the Contractor's surety of such delay, neglect, or default, specifying the same, and directing that said default be cured.

If the Contractor, within a period of ten (10) days after the date of such notice, shall not proceed in accordance therewith, then the City shall, upon written certification by the Engineer of the fact of such delay, neglect or default and the Contractor's failure to comply with such notice, have full power and authority to forfeit the rights of the Contractor and at its option:

1. Call upon the surety to complete the work in accordance with the terms of the contract;
2. Take over the work, including any or all materials and equipment on the ground as may be suitable and acceptable, and complete the work by or on its own force account;
3. Enter into a new agreement for the completion of said contract according to the terms and provisions thereof;
4. Use such other methods as, in the opinion of the City, shall be required for the completion of said contract in an acceptable manner.

All resulting costs and charges incurred by the City, including the cost of completing the work under contract, shall be deducted from any monies due or which may become due on such contract. In case the expenses so incurred by the City shall be less than the sum which would have been payable under the contract if it had been completed by said Contractor, then said Contractor shall be entitled to receive the difference subject to any claims for liens thereon which may be filed with the City or any prior assignment filed with it, and in case such expense shall exceed the sum which would have been payable under the contract, the Contractor and the surety shall be liable and shall pay to the City the amount of such excess.

### **109.11 Removal of Equipment.**

In the case of annulment or termination of this contract before completion from any cause whatever, the Contractor, if notified to do so by the City, shall promptly remove any part or all of the Contractor's equipment and supplies from the property of the City, failing which the City shall have the right to remove such equipment and supplies at the expense of the Contractor.

### **109.12 Contractor's Right to Stop Work or Terminate Contract.**

If the work should be stopped under an order of any court, or other public authority, for a period of three (3) months, through no act or fault of the Contractor or anyone employed by the Contractor, or if the Engineer should fail to make a partial payment within thirty (30) days after it is due; or if the City shall fail to pay the Contractor within a reasonable time any sum certified by the Engineer; then the Contractor may, upon seven (7) days written notice to the City and the Engineer, stop work or terminate this contract and recover from the City payment for all work executed and any loss sustained upon any plant or materials.

### **109.13 Emergency Deferment or Cancellation of Contract.**

The Board of Public Works and the Contractor, in the event of a national emergency that creates a shortage of materials, labor, or equipment, (1) by reason of war conditions involving the United States, or (2) by reason of orders of the United States Government or its duly authorized agencies, or (3) executive order with respect to prosecution of war or national defense, may upon a finding by the Board that such emergencies do exist, and by reason of which such Contractor is unable to proceed with the work under the contract, defer such work in whole or in part, or cancel such contract, or any part thereof, as hereinafter provided.

#### **109.13(a) Deferment.**

In all cases where work under the contract is deferred, it shall be done by written agreement between the City and Contractor stating the terms and conditions of such deferment. If agreement upon the terms and conditions of such deferment cannot be agreed upon, the original contract is to remain in full force and effect.

#### **109.13(b) Cancellation.**

Where the contract, or any portion thereof, is terminated or canceled for reasons other than those enumerated in Section 109.12, and the Contractor released before all items of work included in his contract have been completed, payment will be made for the actual items of work completed at contract unit prices, or agreed prices where no unit prices are contained in the contract, and no claim for loss of anticipated profits shall be considered.

Acceptable materials, obtained by the Contractor for the work, that have been inspected, tested and accepted by the City and that are not incorporated in the work, may, at the option of the Board of Public Works be purchased from the Contractor at actual cost as shown by receipted bills at such points of delivery as may be designated by the Engineer.

If agreement upon the terms and conditions of cancellations of all or any part of the contract cannot be agreed upon, the original contract, or uncompleted part thereof, shall remain in full force and effect.

### **109.14 Mobilization.**

Mobilization shall consist of the work and operations necessary for the movement of personnel, equipment, supplies and incidentals to the project site, and for the establishment of all Contractor's offices, buildings, sanitary and other facilities necessary for work on the project; and of all other work and operations which must be performed or for which costs must be incurred before beginning work on the various items on the project site.

Mobilization will be measured for payment as a single complete unit of work, acceptably performed. This item of work, measured as provided above, shall be paid for one time during the life of the contract at the contract lump sum price for Mobilization, which price shall be full compensation for supplying and furnishing all materials, facilities and services, and for performing all work necessary for the completion of this item, including all necessary repetitions caused by any and all suspensions of the work during the life of the contract. The contract lump sum shall be payable to the Contractor in accordance with the following schedule:

Part I - General Conditions

1. When twenty-five (25) percent or more of the original contract amount is earned, fifty (50) percent of the amount bid for Mobilization will be paid.
2. When seventy-five (75) percent or more of the original contract amount is earned, one hundred (100) percent of the amount bid for Mobilization will be paid.

When the contract does not include a separate contract item for Mobilization, then all the work herein before prescribed, required and performed will not be separately measured for payment, but will be considered incidental to other items in the contract.

## **ARTICLE 110 - MEASUREMENT AND PAYMENT**

---

### **110.1 Measurement of Quantities.**

The Contractor will be paid for the actual amount of work performed in accordance with the contract, as shown by the final measurements or on the basis of plan quantities.

All work completed under the contract will be measured for payment by the Engineer according to United States standard measure units. The method of measurement and computations to be used in the determination of quantities of material furnished and of work performed under the contract will be those specified for the various items elsewhere in these Specifications or generally recognized as conforming to good engineering practice.

The completed work will be measured for final payment by the Engineer, as to determine the quantities of such items of work performed, except when contract change orders have been executed providing for other methods of measurement.

All materials shall be delivered in vehicles bearing plainly legible identification marks and numbers. The Engineer reserves the right to measure truck bodies to check the volumes marked on tickets for materials paid for on a volume basis.

Each load of material shall be accompanied by a ticket which shall show the type of material, the volume or weights (gross, tare and net), the vehicle identification marks and numbers, the date, and the source of the material. Material tickets for pay items received on the project shall be presented to the City Inspector within twenty-four (24) hours after delivery. Tickets presented after this time may be rejected due to the inability of the City to substantiate the basis of material delivered to the project.

Individual loads of material which are specified for measurement by the cubic yard shall be measured to the nearest cubic yard except where such materials are weighed for measurement. Material specified to be measured by the cubic yard may be weighed and the weights will be converted to cubic yards for payment purposes. Select Fill materials will be considered to have a unit weight of 2,835 pounds per cubic yard. Factors for conversion from weight measurements to volume measurements for other materials will be determined by the Engineer before such method of measurement of pay quantities is used.

Material specified to be measured by the ton (2,000 pounds) shall be weighed on platform scales or other approved scales, furnished by and at the expense of the Contractor. Said scales shall be satisfactory to the Engineer and they shall be tested by the Engineer or by authorized testing firms or agencies as often as the Engineer may deem necessary to insure the accuracy of the scales.

The term "gage", when used in connection with the measurement of plates, will mean the U. S. Standard Gage, except that when reference is made to the measurement of metal sheets used in the manufacture of corrugated metal pipe, metal plate pipe culverts and arches, and metal cribbing, then the term "gage" will mean that specified in AASHTO Designation: M 36 or M 167 for galvanized steel sheets and will mean that specified in AASHTO Designation: M 196 or M 197 for aluminum alloy sheets.

When the term "gage" refers to the measurement of wire, it will mean the wire gage specified in AASHTO Designation: M 32.

When standard manufactured items are specified such as fence, wire, plates, rolled shapes, pipe, conduit, etc., and these items are identified by gage, unit weight, section, dimensions, etc., such identification will be considered to be nominal weights or dimensions. Unless more stringently controlled by tolerances in cited Specifications, manufacturing tolerances established by the industries involved will be accepted.

## **110.2 Partial Payments.**

Partial payments based on the value of the work satisfactorily performed or satisfactory materials furnished, at contract or agreed unit or lump sum prices, will be made to the Contractor as the work progresses, except that partial payments will not be made if the Contractor is in noncompliance with any order given to the Contractor by the Engineer pursuant to the contract.

Twice each month (provided that a payment of \$1,000 or more becomes due, which amount may at the Engineer's discretion be reduced for contracts of \$25,000 or less) the Contractor will prepare an estimate of the quantities of work performed and the value thereof at contract or agreed unit or lump sum prices. The estimate will be prepared on forms provided by the Engineer. After review and acceptance of the estimate by the Engineer, the City shall issue a partial payment. **Workforce Profiles shall be approved prior to the first partial payment.**

The quantities included shall be computed to reflect the approximate amount of work completed, or substantially completed under each of the pertinent contract items to the date of the estimate less, in each case, an allowance adequate to cover contingencies and costs still to be incurred incident to finishing, maintaining, repairing and restoring of the work, and to cover possible variations between the contract and final quantities in instances where contract quantities are used as a basis for the estimate.

The Engineer may, upon presentation by the Contractor of receipted bills, freight bills or other satisfactory evidence of payment, include in the estimate prepared for partial payment the value of nonperishable materials which are to form a part of the completed work, produced or purchased, and delivered and stored in the vicinity of the work at such location where they will be available for ready incorporation into the work. The amounts paid for such materials shall go to reduce the amount of other partial or final payments due to the Contractor for the work performed as the materials are incorporated into the completed work.

From the total amount of the estimate, determined as provided above, there shall be deducted an amount equal to five (5) percent of the total amount of such estimate to be retained by the City until fifty (50) percent of the work has been completed. At fifty (50) percent completion, further partial payments shall be made in full to the Contractor and no additional amount shall be retained unless the Engineer certifies that the job is not proceeding satisfactorily in accordance with Section 110.5 herein or, the amount retained is not sufficient to provide for recovery of liquidated damages assessable against the Contractor. At fifty (50) percent completion or at any time thereafter, when the progress of the work is not satisfactory, additional amounts may be retained but, in no event shall the total retainage be more than ten (10) percent of the value of the work completed. When the work has been substantially completed except the work which cannot be completed because of weather conditions, lack of materials or other reasons which in the judgment of the Engineer are valid reasons for noncompletion, the Engineer may make additional payments retaining at all times in the amounts sufficient to cover the estimated cost of the work still to be completed or in the alternative may pay

out the entire amount retained and receive from the Contractor a guarantee in the form of a bond or other collateral sufficient to insure the completion of the job.

The payment of any current estimate prior to final acceptance of the work by the City shall in no way constitute acceptance of the work, nor in any way prejudice or affect the obligation of the Contractor, to repair, restore, correct, renew or replace any defects or imperfections in the construction or in the strength or quality of the materials used in or about the construction of the work under contract and its appurtenances, or any damage due or attributable to such defects, which defects, imperfections or damage shall have been discovered on or before the final inspection or acceptance of the work. The Engineer shall be the sole judge of such defects, imperfections or damage and the Contractor shall be liable to the City for failure to correct the same as provided herein.

### **110.3 Setoffs.**

Where any deductions from or forfeitures of payment in connection with the work of this contract are duly and properly declared or imposed against the Contractor, in accordance with the terms of this contract, State Laws or Ordinances of the City, the total amount thereof may be withheld from any money whatsoever due or to become due the Contractor under the contract, and when deducted shall be deemed and taken as payment in such amount. The City also has the equitable right to set off against any sum due and payable the Contractor under this contract any amount the City determines the Contractor owes the City, whether arising under this contract or any other agreement or otherwise.

### **110.4 Unpaid Wages.**

Whenever, in the opinion of the Engineer, it may be necessary for the progress of the work to secure to any of the employees engaged in the work under this contract any wages which may then be due them, the City is hereby authorized to pay the employees the amount due them or any lesser amount, and the amount so paid them as shown by their receipts, shall be deducted from any monies that may be or become payable to the Contractor.

### **110.5 Acceptance and Final Payment.**

When the work has been accepted by the Engineer in accordance with Section 105.15, the Engineer will prepare the final estimate of the quantities of the various classes of work performed. After the Contractor reviews and accepts the final estimate, and after the Contractor submits an affidavit certifying full compliance with Section 66.0903, Wisconsin Statutes, and receipt of evidence of such compliance by all subcontractors, the Engineer will recommend to the Finance Director that the final payment be made. Within thirty (30) days after such action the Contractor will be paid the entire sum then due, subject to deductions for prior payments and setoffs under the contract.

All prior partial estimates and payments shall be subject to correction in the final estimate and payment.

The making of final payment shall not release the surety nor constitute a waiver of rights by the City. The guarantee of Section 105.16 is cumulative and not exclusive.

### **110.6 Payment Withheld.**

Notwithstanding any responsibility of the surety and the Contractor for the following matters, the City may withhold, or on account of subsequent discovered evidence, nullify the whole or a part of any certificate to such extent as may be necessary to protect itself from loss on account of:

1. Defective work not remedied.
2. Claims filed against the Contractor.
3. Failure of the Contractor to make payments promptly to subcontractors or for laborers or material.
4. A reasonable doubt that the contract can be completed for the balance then unpaid.
5. Damage to another Contractor.

When the above grounds are removed, payments shall be made for amounts withheld because of them.

### **110.7 Differing Site Conditions.**

The Contractor shall promptly, and before such conditions are disturbed, except in the event of an emergency, notify the Engineer by written notice of:

1. Subsurface or latent physical conditions of the site differing materially from those indicated in this contract, or
2. Unknown physical conditions at the site, of an unusual nature, differing materially from those ordinarily encountered and generally recognized as inherent in the work of the character provided for in this contract.

The Engineer shall promptly investigate the conditions. If the Engineer finds that such conditions do materially differ and cause an increase or decrease in the Contractor's cost of, or the time required for, performance of any part of the work under this contract, whether or not changed as a result of such conditions, an equitable adjustment shall be made and the contract modified in writing accordingly.

No claim of the Contractor under this Section shall be allowed unless the Contractor has given the required notice, except that the Engineer may extend the prescribed time.

No claim by the Contractor for an equitable adjustment hereunder shall be allowed if asserted after final payment under this contract.

### **110.8 Claims for Adjustment in Compensation.**

The compensation provided herein constitutes the total payment (subject to authorized adjustments) payable to Contractor for performing the work. All duties, responsibilities and obligations assigned to or undertaken by Contractor shall be at its expense without change in the Contract Price. This includes without limitation loss or damage arising from the nature of the work or from the action of

## Part I - General Conditions

the elements, or from any unforeseen difficulties which may be encountered during the prosecution of the work until the final acceptance by the Engineer, expenses incurred in consequence of the suspension or discontinuance of the work as herein specified; and for any infringement of patent, trademark, or copyright; and for completing the work according to the contract.

Should the Contractor contend that it is entitled to additional compensation, Contractor shall within seven (7) days after the occurrence of the event giving rise to the claim deliver written notice to the Engineer, stating the general nature of the claim. The Engineer shall render a timely decision. Claims not presented within seven (7) days above mentioned, but presented at some later time, shall not be entitled to have such review.



## Part II - Earthwork and Miscellaneous Construction

ARTICLE 201 - EXCAVATION CUT .....	1
201.1    General.....	1
201.2    Construction Methods.....	1
201.3    Description.....	5
201.4    Materials.....	5
201.5    Method of Measurement.....	6
201.6    Basis of Payment.....	7
ARTICLE 202 - FILL.....	8
202.1    Description.....	8
202.2    Materials.....	8
202.3    Construction Methods.....	9
202.4    Method of Measurement.....	12
202.5    Basis of Payment.....	12
ARTICLE 203 - REMOVAL OF MISCELLANEOUS STRUCTURES.....	14
203.1    Description.....	14
203.2    Construction Methods.....	14
203.3    Method of Measurement.....	17
203.4    Basis of Payment.....	18
ARTICLE 204 - CLEARING AND GRUBBING.....	20
204.1    Description.....	20
204.2    Construction Methods.....	20
204.3    Method of Measurement.....	20
204.4    Basis of Payment.....	20
ARTICLE 205 - ADJUSTMENT OF CASTINGS.....	21
205.1    General.....	21
205.2    Construction Methods.....	21
205.3    Measurement and Payment.....	22
ARTICLE 206 - OBLITERATING STREET .....	23
206.1    Description.....	23
206.2    Construction Methods.....	23
206.3    Method of Measurement.....	23
206.4    Basis of Payment.....	24
ARTICLE 207 - SEEDING .....	25
207.1    Description.....	25
207.2    Materials.....	25
207.3    Construction Methods.....	30
207.4    Acceptance and Guarantee.....	34
207.5    Method of Measurement.....	34
207.6    Basis of Payment.....	34

ARTICLE 208 - SODDING .....	36
208.1 Description.....	36
208.2 Materials. ....	36
208.3 Construction Methods.....	36
208.4 Acceptance and Guarantee.....	38
208.5 Method of Measurement.....	39
208.6 Basis of Payment.....	39
ARTICLE 209 - TREES, SHRUBS, PERENNIALS AND GRASSES .....	40
209.1 Description.....	40
209.2 Materials. ....	40
209.3 Digging, Handling and Packing Plant Stock.....	41
209.4 Construction Methods.....	42
209.5 Backfill Material. ....	46
209.6 Acceptance and Guarantee.....	49
209.7 Method of Measurement.....	50
209.8 Basis of Payment.....	50
ARTICLE 210 - EROSION CONTROL .....	52
210.1 Description.....	52
210.2 Materials. ....	56
210.3 Construction Methods.....	58
210.4 Method of Measurement.....	58
210.5 Basis of Payment.....	59
ARTICLE 211 - TERRACE RAIN GARDEN.....	61
211.1 Description.....	61
211.2 Materials. ....	61
211.3 Construction Methods.....	62
211.4 Method of Measurement.....	63
211.5 Basis of Payment.....	63
ARTICLE 212 - RIPRAP .....	64
212.1 Description.....	64
212.2 Materials. ....	64
212.3 Construction Methods.....	65
212.4 Method of Measurement.....	65
212.5 Basis of Payment.....	65
ARTICLE 213 - MISCELLANEOUS .....	67
213.1 General.....	67
213.2 Description.....	67
213.3 Method of Measurement.....	67
213.4 Basis of Payment.....	67

## **ARTICLE 201 - EXCAVATION CUT**

---

### **201.1 General.**

Excavation Cut shall consist of the loosening, loading, hauling and disposal of all materials of every description encountered in the performance of the work other than specific materials which have been classified and bid upon, including Rock Excavation, Removal of Miscellaneous Structures, and Clearing and Grubbing. This work shall include the removal and disposal of surface and base course and unsuitable materials, the trimming and finishing of the roadway, and maintaining such work in a finished condition until acceptance.

Rock excavation shall include all hard, solid rock in ledges, bedded deposits and unstratified masses and all conglomerate deposits or any other material so firmly cemented as to present all the characteristics of solid rock; which material is so hard or so firmly cemented that, as determined by the Engineer, it is not practical to excavate and remove same without blasting or the use of rippers. Rock excavation shall also include all rock boulders necessary to be removed having a volume of one cubic yard (27 cubic feet) or more. Rock excavation shall not apply to plain or asphalt bound bases or surface courses of macadam, gravel, or broken stone.

### **201.2 Construction Methods.**

#### **201.2(a) Excavation Cut.**

All excavation as shown on the accompanying cross sections and plans shall be done by the Contractor to the line and grade established by the Engineer. All topsoil and organic materials shall be stripped from the project as shown on the cross sections, except all work done in the vicinity of any tree located in the terrace shall be completed in accordance with section 107.13 Tree Protection Specification and as directed by the Engineer. All earth subbase shall be compacted in accordance with the requirements for Standard Compaction, Section 202.3. The finished grade in the terrace shall be a straight line grade between the top of the curb and the top of the outside edge of the sidewalk. The Contractor shall make all major excavation of existing material in the area between the curb line and the property line before curb and gutter is installed.

All excavation terminating on clayey soils shall be accomplished with a backhoe equipped with a cleaning bucket. No rubber tire equipment shall be allowed on a subgrade terminating on clayey soils except for the purpose of test rolling as directed in Section 201.5.

No mechanical equipment or vehicles will be allowed over or on concrete curb and gutter, concrete sidewalk and concrete driveway aprons for at least seven (7) days after pouring of said structures or per Subsection 301.8(c), whichever is sooner; any damage caused by the Contractor shall be removed and replaced at the Contractor's expense. No material either from or for the area back of the curb line shall be dumped or shoved onto new asphalt pavement for rehandling by mechanical equipment.

Concrete curb and gutter, concrete sidewalk, concrete driveway aprons and pavements damaged or dislocated in line or elevation or both by the Contractor in the work of excavating, filling, rolling and grading shall be replaced by the Contractor immediately at the Contractor's expense. The Contractor shall operate equipment in such a manner that equipment tires or tracks do not discolor, mark, and damage existing curb and gutter, sidewalk or pavements. The Contractor shall take all necessary precautions to protect existing trees in the terrace. When the trees are to be removed, they shall be so designated by the Engineer and payment made as described under Clearing and Grubbing.

## Part II - Earthwork

The Engineer reserves the right to order additional excavation, when conditions of the subsoil require such extra work. The additional excavation shall be measured in the field and calculated from those measurements. Unless included as a bid item, payment for additional excavation shall be made on the basis of the unit price bid per cubic yard of Excavation Cut. Except when ordered by the Engineer, if the subbase has been undercut by the Contractor, then the Contractor shall, at no expense to the City, return the subbase under the roadway, curb and gutter and sidewalk to the correct grade with compacted crushed stone as directed by the Engineer.

Unless otherwise specified, the Contractor shall dispose of all excess excavation cut, broken concrete, and debris at a site to be provided by the Contractor at no additional cost to the City. The contractor shall recycle 90% of all concrete, including pavement, curb and gutter and sidewalk, and asphalt pavement. If the contractor can demonstrate a surcharge is being added to the tipping fee, the recycling requirement may be waived. The recycled material does not have to be used on the project from which it was removed. When a point of disposal of excess excavation cut is specified in the contract, then all excess excavation cut shall be the property of the City and shall be hauled to and dumped and spread at the point of disposal noted in the contract to the satisfaction of the Engineer. All costs of disposal of excess excavation cut shall be included in the unit price bid for Excavation Cut. When directed by the Engineer, the Contractor shall dispose of excess excavation at a point of disposal other than that noted in the contract. Where the length of haul is decreased the City shall deduct \$0.20 per cubic yard per mile from the final payment for each cubic yard so disposed. When the length of haul is increased, the City shall add \$0.20 per cubic yard per mile to the final payment for each cubic yard so disposed. There shall be allowed a minimum length of haul of four miles for the determination of the increase or decrease of the length of haul. When excess excavation is delivered to private properties or other sites by the Contractor without the Engineer's permission, then the City shall deduct seven dollars (\$7.00) per cubic yard from final payment for each cubic yard so disposed. The Contractor shall dispose of stones, broken rock and boulders at no cost to the City.

During construction, the roadway, ditches and channels shall be maintained in a well drained condition at all times by keeping the excavation areas and embankments sloped to the approximate section of the ultimate earth grade. Blading or leveling operations will be required when placing embankments and during the process of excavation except when such excavation is in ledge rock or areas where leveling is not practical or necessary. If it is necessary, in the prosecution of the work, to interrupt existing surface drainage, sewers, or under-drainage, temporary drainage shall be provided until permanent drainage work is completed. The construction of all temporary drainage installations shall be considered as incidental to the construction of the work. The Contractor shall be responsible for and shall take all reasonable and necessary precautions to preserve and protect all existing tile drains, sewers, and other sub-surface drains, or parts thereof, which in the judgment of the Engineer may be continued in service without change. Any and all damages to such facilities resulting from negligence or carelessness on the part of the Contractor's operations shall be repaired at the Contractor's expense.

All suitable material removed from excavation shall be used in the construction of the terraces, as far as practicable, and at such other places as shown on the plans. All excavated slopes or areas and all embankment slopes or areas, designated to be covered with topsoil, shall be undercut or underfilled to the necessary depth to provide for the specified amount of topsoil to be placed and finished to the required grade lines and section. Excavating shall be so performed as to avoid removing or loosening any material outside the required slopes, and any such material which may be removed or loosened shall be replaced and thoroughly compacted to the required cross section. All intersecting roads,

## Part II - Earthwork

approaches, entrances and driveways shall be graded as shown on the plans or as laid out in the field by the Engineer. The work of constructing intersections and private entrances, trimming shoulders and slopes, finishing and blading the earth subgrade and completing the ditches to proper alignment, grade and cross section shall follow the rough grading closely. Grading operations shall not be performed to the detriment of the work of trimming and finishing the roadway and blading and maintaining the roadbed and earth subgrade. The area of erosive land exposed to the elements by the grading operations at any one time shall be subject to the approval of the Engineer and the duration of such exposure prior to final trimming and finishing of the area shall be as short as practicable. Construction in and adjacent to storm sewers, rivers, streams, lakes, or other waterways shall be performed in such a manner as to avoid washing, sloughing or deposition of materials into such waterways which would obstruct or impair the flow thereof thus endangering the roadway or stream banks, or which would result in undue or avoidable contamination, pollution or siltation of such waterways. The Engineer shall have full authority to order the suspension of grading and other operations pending the adequate and proper performance of the trimming, finishing and maintenance work or to restrict the area of erosive land exposed to the elements.

The grading, trimming and finishing shall be completed prior to construction of the base course. Adjustment in slopes, to avoid injury to standing trees or to harmonize with existing landscape features, especially at the intersection of cuts and fills, shall be made and the transition to such adjusted slopes shall be gradual. The crests of earth cut banks shall be rounded as indicated on the plans or as directed by the Engineer. All earth slopes shall be constructed to a surface that will merge with adjacent terrain and be in substantial accordance with the cross sections. The horizontal serrated condition of slopes ordinarily left by excavating equipment shall be partially smoothed by means of blading or other operations so the slopes will have a general contour of the required slope but may be slightly rough and irregular. During grading operations and pending placement of base course, the Contractor shall provide continuous maintenance of the entire roadbed and perform all blading and repair work necessary to keep the grade smooth and to the required grade and cross section. Washouts caused by erosion shall be refilled with acceptable material and properly compacted.

No project shall be accepted until all excess mud, terrace dirt, asphalt material, rocks and crushed stone have been removed from the sidewalk, terrace, gutter and pavement. Work days may be charged against the Contractor until all cleanup is complete and to the satisfaction of the Engineer.

Excavation for sidewalks, and driveways and placement of topsoil is not included in excavation cut but shall be subsidiary work to the respective bid items.

The volume of concrete curb and gutter and concrete pavement to be removed is included in the total excavation.

The work involved with the placement of suitable fill obtained on site through excavation cut shall be considered as subsidiary work pertaining to excavation cut. The work shall include the formation, compaction, shaping, sloping, trimming, finishing and maintaining of embankments consisting of fill materials obtained on site and all other work incidental thereto.

The work involved with the placement of salvable select fill materials obtained on site through excavation cut shall be considered as subsidiary work pertaining to excavation cut unless the Proposal includes separate bid items for such materials.

The Contractor shall limit the excavation at all tree locations in accordance with section 107.13 Tree Protection Specification. All costs shall be considered incidental to Excavation Cut.

201.2(b) Rock Excavation.

Rock, when encountered in excavation, shall be removed to a depth of six (6) inches below the earth subgrade between the outer limits of the shoulder slopes. In the event design details covering the depth of rock excavation are incorporated in the plans, the work shall conform thereto. When excavation methods chosen and employed by the Contractor leave undrained pockets in the rock surface, the Contractor shall, at no expense to the City, properly drain such depressions or, when permitted by the Engineer, fill the depressions with approved impermeable material. Excavation of rock cuts shall be performed by such methods and with such equipment that the resulting backslopes conform to the slopes shown on the plans or to the slopes designated by the stakes set for excavation, without creating depressions in or substantial displacement of material outside the lines, limits or slope planes defined by the stakes. The backslopes in rock cut shall be “scaled” to dislodge loose rock, and material so removed shall be disposed of in the manner prescribed for other excavation. The slopes of rock cuts when designated to receive topsoil shall be undercut the necessary depth to provide for placing the specified amount of topsoil and finished to the required section.

201.2(c) Test Rolling Street Subgrades and Base Course Preparatory to Paving.

All test rolling shall be on subgrade, unless test rolling on base course is authorized by the Engineer as provided herein.

The truck shall test roll the section in the presence of the Engineer. Test rolling shall be accomplished in a series of traverses parallel to the centerline of the street. The truck shall traverse in the general location of each lane of the street, but at least two traverses shall be performed in the roadway. (Streets measuring thirty-two (32) feet from face of curb to face of curb shall be considered as having three lanes.)

Additional passes along the traverse, as directed by the Engineer, shall be performed to fix the location of soft or yielding areas. Soft or yielding areas, rolling or wave action of the subgrade, depressions, transverse cracking and/or alligator cracking resulting from the test roll shall be indicative of an unsatisfactory subgrade. Such areas shall be repaired, consolidated, and retested as determined by the Engineer.

Unsatisfactory areas in fill sections shall be repaired at the expense of the Contractor. Unsatisfactory areas in cut sections shall be paid for as excavation cut and the applicable select fill item(s).

On private contracts the Developer and the Developer’s consulting Professional Engineer may jointly request the Engineer to permit test rolling on the installed base course rather than the subgrade. On City of Madison contracts the decision to test roll on the installed base course or the subgrade will be made by the Engineer. The construction methods for test rolling of the installed base course shall be the same as those methods prescribed for testing on the subgrade, except that the perceptible displacement or yielding of base course shall be considered indicative of an unsatisfactory subgrade.

201.2(d) Finish Grading.

Work under this item shall include final grading of the entire site to the finish grades as shown on the plan set or as directed in the field, preparing the site for seeding, matting and mulching. The seed bed and finish grades shall be set and approved by the field engineer or his designee prior to seeding the site.

**201.3 Description.**

201.3(a) Under Drain, 6 Inch, Wrapped.

This work shall include all labor, equipment, materials, and incidentals required to install and connect six-inch perforated pipe under drain, wrapped, including open graded base course and geotextile fabric, as shown on the plans or as directed by the Engineer. See the City of Madison Standard Specification for Public Works Construction, Standard Detail Drawing 4.05 for additional information.

All costs associated with the connection of the under drain to the inlet, as shown on the plans or as directed by the Engineer, shall be considered incidental to this item.

The work involved with the placement of the Geotextile Fabric, type SAS as herein provided, and the perforated pipe shall be in accordance with Sections 612 and 645 of the latest edition of the Standard Specifications for Highway and Structure Construction of the State of Wisconsin, Department of Transportation.

201.3(b) Geotextile Fabric, Type SAS (Non-Woven).

This work shall be in accordance with Section 645 of the latest edition of the Standard Specifications for Highway and Structure Construction of the State of Wisconsin Department of Transportation and as herein provided. Geotextile Fabric, Type SAS (Non-Woven) shall be used in undercut areas.

201.3(c) Test Rolling Street Subgrades and Base Course Preparatory to Paving.

This work shall be in accordance with the pertinent provisions of Article 201 and 202 of the Standard Specifications, unless revised by the Engineer

**201.4 Materials.**

201.4(a) Under Drain, 6 Inch, Wrapped.

The geotextile fabric shall comply with the requirements for Geotextile Fabric, Type SAS (Non-Woven).

The Perforated Pipe Under Drain shall comply with the requirements of Section 612.2.5 of the latest edition of the Standard Specifications for Highway and Structure Construction of the State of Wisconsin, Department of Transportation.

The Pipe Wrapping shall comply with the requirements of Section 612.3.2 of the latest edition of the Standard Specifications for Highway and Structure Construction of the State of Wisconsin, Department of Transportation.

Open Graded Base Course shall meet the requirements of size No. 2 of 501.2.5.4.4 of the latest edition of the Standard Specifications for Highway and Structure Construction of the State of Wisconsin, Department of Transportation.

201.4(b) Geotextile Fabric, Type SAS (Non-Woven).

The fabric shall comply with the following requirements:

Test	Method	Minimum Value
Tensile Strength (lbs)	ASTM D-4632	200
Puncture Strength (lbs)	ASTM-4833	95
Apparent Opening Size (U.S. Standard Sieve)	ASTM D-4751	70
Permittivity (Gal/min/ft <sup>2</sup> ) at 50 mm	ASTM-4491	25

201.4(c) Test Rolling Street Subgrades and Base Course Preparatory to Paving.

The Contractor shall furnish a fully loaded tri-axle dump truck for test rolling. The truck shall be equipped with tires used for highway use (non-floatation) with 100 psi or greater inflation pressure. Test rolling shall be conducted with the “pusher axle(s)” wheels off the roadway. The Contractor shall provide a ticket to document the gross weight of the truck.

**201.5 Method of Measurement.**

Unless otherwise specified in the Contract, the pay quantity for Excavation Cut will be the sum of the quantity for “unclassified excavation” and for additional excavation, including undercut.

The quantity of unclassified excavation to be paid for as Excavation Cut shall be set forth in the contract plans without measurement thereof. Any earthwork modifications to the contract plan quantity caused by corrections or revisions of the original contract plans which have been approved by the Engineer will be measured in cubic yards in its original position, computed by the method of average end areas. The contract quantity shall be adjusted upward or downward accordingly to determine the final pay quantity.

Additional excavation, including undercut, shall be measured in the field and the volume in cubic yards shall be computed from those measurements.

Rock Excavation shall be measured in the field, the vertical measurements for determining end areas extending from the surface of the rock to a depth of six (6) inches below the subgrade. Where Rock Excavation is encountered in an area previously included as Excavation Cut, the volume of Excavation Cut shall be reduced by the volume of Rock Excavation.

Boulders and surface stone of one (1) cubic yard or more in volume will be measured individually and the volume computed from average dimensions taken in three directions.

The installation of Under Drain, 6 Inch, Wrapped as described above shall be measured by the lineal foot of completed and accepted work.

Geotextile Fabric, Type SAS (Non-Woven) shall be measured by the square yard of surface area upon which the fabric has been placed and accepted.



**201.6 Basis of Payment.**

The contract price for all Article 201 items listed above shall be payment in full for furnishing and installing fabric, all equipment, tools, labor and incidentals necessary to complete the work of excavation and related work. This shall include placement of suitable materials within the project limits as specified in Subsection 201.2(1) and disposal of excess or unsuitable materials as specified.

## **ARTICLE 202 - FILL**

---

### **202.1 Description.**

This item shall consist of furnishing and placing and compacting materials in accordance with these Specifications, the Contract, as shown on the plans and cross sections, or as directed by the Engineer. The work shall be done at the locations and to the lines and grades as shown on the plans or as directed by the Engineer.

### **202.2 Materials.**

#### **202.2(a) Fill.**

Suitable material for fill shall consist of earth which is free from boulders, masonry or other unacceptable materials. Earth containing sod, organic matter or humus shall not be included in this classification. This classification does not include Select Fill and Topsoil.

#### **202.2(b) Select Fill.**

Select Fill shall refer to processed or selected natural materials. The material shall consist of sand, a mixture of sand with gravel, crushed stone, or crushed concrete, more generally identified as pit run sand, pit run sand and gravel, crushed stone base course, crusher run crushed stone, and crushed concrete. The gradation of the material shall be such that not less than one hundred (100) percent passes a six (6) inch sieve, not less than eighty-five (85) percent by weight passes a three (3) inch sieve, and not less than twenty-five (25) percent by weight passes a Number 4 sieve. The material shall be free from dirt, debris, frozen materials, vegetable matter, and lumps or balls of clay. The source and the material to be used for the various purposes shall be subject to the approval of the Engineer.

The definitions set forth below shall apply to this material:

1. Sand (Pit Run Sand): granular material almost entirely passing the Number 4 sieve and predominantly retained on the Number 200 sieve. The gradation of the material passing the Number 4 sieve shall meet the requirements for 209.2.1 and Grade 1 or Grade 2 of Section 209.2.2, "Gradation of Material Passing the No. 4 Sieve", of the latest edition of the Standard Specifications for Highway and Structure Construction of the State of Wisconsin, Department of Transportation.
2. Gravel: rounded to subangular granular material, predominantly retained on a Number 4 sieve, obtained from deposits created by the reduction or disintegration of rock.
3. Crushed Stone: hard, durable particles of crushed stone resulting from the artificial crushing of rock, boulders, or large cobble stones.
4. Crushed Concrete: granular material resulting from the artificial crushing of hardened concrete.
5. Crushed Aggregate (Gradation #4, 9" Maximum size): That Gradation #4 is to be a sorted or screened blast or shot rock. Gradation shall be such that not less than one hundred (100) percent passes a six (6) inch sieve, not less than eighty-five (85) percent by weight passes a

## Part II - Earthwork

three (3) inch sieve, and not less than twenty-five (25) percent by weight passes a Number 4 sieve.

6. Crushed Aggregate (Gradation #5, Breaker Run): Gradation shall be such that not less than one hundred (100) percent passes a six (6) inch sieve, not less than eighty-five (85) percent by weight passes a three (3) inch sieve, and not less than twenty-five (25) percent by weight passes a Number 4 sieve.

The materials to be used as Select Fill for the various purposes intended including constructing embankments, backfilling excavations for unsuitable materials, backfilling trenches, and backfilling excavations for structures, shall be as specified in the special provisions or on the Proposal page when Select Fill is included as a bid item.

### 202.2(c) Salvable Crushed Stone.

When directed by the Engineer, the Contractor shall segregate salvable crushed stone, free of earth, debris and vegetable matter, from the existing pavement, and shall use the same as a Select Fill material under concrete curb and gutter, concrete sidewalk and pavement. This work will be considered incidental to Excavation Cut unless the Proposal Page includes a bid item for Salvable Crushed Stone.

### 202.2(d) Clear Stone.

Clear stone shall conform to gradation no. 1 as specified in Section 401.1(b) - Materials.

### 202.2(e) Crushed Stone.

Crushed stone shall conform to either gradation no. 2 for 1-1/4" or gradation no. 3 for 3/4" as specified in Section 401.1(b) - Materials.

### 202.2(f) Topsoil.

Topsoil shall be of humus bearing soil, adapted to the sustenance of plant life and commonly known as black dirt, and shall be free of stones, debris, vegetable material and excesses of peat, sand, or clay.

### 202.2(g) Riprap Filter Fabric.

Riprap Filter Fabric shall consist of furnishing and installing geotextile fabric, Type HR in accordance with the latest edition of the Standard Specifications for Highway and Structure Construction of the State of Wisconsin, Department of Transportation and these special provisions.

## **202.3 Construction Methods.**

### 202.3(a) General.

Where the terms "Standard Compaction" and "Special Compaction" appear herein, they shall be as defined in Subsections 202.3(b) and 202.3(c) below.

Fill materials except Select Fill, Salvable Crushed Stone and Topsoil shall be compacted in accordance with the requirements for Standard Compaction unless otherwise specified herein or in

the Contract. Select Fill materials and Salvable Crushed Stone materials shall be compacted in accordance with the requirements for Special Compaction unless otherwise specified in the Contract. Topsoil shall be lightly compacted in order to minimize future settlement.

The material to be used for backfilling the excavations for unsuitable materials shall be Breaker Run conforming to requirements of Subsection 402.2(f). The material for the backfilling of excavations for bridges, culverts, retaining walls and other structures shall be Select Fill as defined in Subsection 202.2(b) of these Specifications. Such materials shall be compacted in accordance with the requirements for Special Compaction.

Fill material to be used in the construction of embankments under sidewalks, curbs and pavements shall consist of suitable material for fill as defined in Subsection 202.2(a). The maximum size of the material in the upper portion of the embankment, within twelve (12) inches of the subgrade, shall be less than six (6) inches in any dimension. All areas under such embankments shall be stripped of all topsoil and organic materials, and shall be compacted in accordance with the requirements for Standard Compaction before the Fill material for the embankment is placed. Fill material for such embankments shall not be placed on frozen ground. Fill materials for such embankments shall be compacted in accordance with the requirements for Special Compaction.

Fill materials to be placed in those portions of embankments under sidewalks, curbs and pavements which lie beyond the limits of assumed two-to-one slopes extending outward and downward from the outer limits of the finished construction may consist of materials conforming to the requirements of Fill material as defined in Subsection 202.2(a) of these Specifications, except that such materials may contain sod, organic matter and humus. Such materials shall be compacted in accordance with the requirements for Standard Compaction. The Engineer may waive this density requirement for unstable materials permitted to be placed in embankments outside the above designated slopes.

Fill material shall not be compacted when the moisture content is such as to cause excessive rutting by the hauling equipment, or excessive displacement or distortion under the compacting equipment. Where such conditions exist, the fill material shall be allowed to dry prior to compacting. When necessary, drying of such fill material shall be accelerated by aeration or manipulation by means of blade graders, harrows, discs or other appropriate equipment.

When the fill material does not contain sufficient moisture to compact properly, water shall be added in quantities deemed necessary to aid and accelerate and to secure effective compaction.

Topsoil shall be placed at least four (4) inches thick, lightly compacted to minimize future settlement, and shall be graded and raked to the satisfaction of the Engineer. Finished Topsoil areas shall be free of stones, road materials or lumps of dirt.

### 202.3(b) Standard Compaction.

The fill material shall be deposited, spread and leveled in layers not exceeding twelve (12) inches in thickness before compaction. Each layer of the spread and leveled fill material shall be compacted to the degree that no further appreciable consolidation is evidenced under the action of the compaction equipment. The required compaction shall be attained for each layer before any fill material for a succeeding layer is placed thereon.

Hauling and leveling equipment shall be routed and distributed over each layer of the fill material in such a manner as to make use of the compaction afforded thereby. Should the Engineer determine

that such compaction is satisfactory and sufficient, further compaction will not be necessary nor shall special compaction equipment be required. Should the Engineer determine that the compaction is not satisfactory or sufficient, special compaction equipment shall be used to accomplish the compaction. Such special compaction equipment shall include tamping rollers, pneumatic-tired rollers, vibratory rollers, or other types of equipment designed for compaction which will produce the required results in the materials encountered and be subject to the approval of the Engineer.

202.3(c) Special Compaction.

Upon the properly prepared ground surface, the fill material shall be deposited, spread and leveled in layers generally not exceeding twelve (12) inches in thickness before compaction. Each layer of the spread and leveled fill material shall be compacted, by means of suitable compaction equipment, to not less than the specified density before the succeeding layer is placed.

All fill material placed within the limits of assumed two-to-one slopes extending outward and downward from the outer limits of the finished construction shall be compacted to not less than the density specified below.

Fill material in embankments of six (6) feet or less in height shall be compacted to at least ninety-five (95) percent of maximum density for their full depth. Fill material in embankments over six (6) feet in height shall have the top six (6) feet compacted to not less than ninety-five (95) percent of maximum density, and those portions more than six (6) feet below the finished subgrade shall be compacted to at least ninety (90) percent of maximum density.

The maximum density shall be determined in accordance with the test method for Laboratory Compaction Characteristics of Soil Using Modified Effort, ASTM Designation D 1557. The density of compacted fill material shall be determined in accordance with the Test for Density of Soil-in-Place by the Sand-Cone Method, ASTM Designation D 1556, the Test for Density of Soil and Soil Aggregate in Place by Nuclear Methods, ASTM Designation D 2922, or by other approved methods.

In the event the material in the density sample differs in percentage of aggregate retained on a No. 4 sieve from that in the sample upon which maximum density was determined, the maximum density shall be adjusted in accordance with approved procedure.

The foregoing density requirements will not apply to portions of embankments constructed of materials which, because of numerous large stones or high percentages of material retained on the No. 4 sieve, cannot in the determination of the Engineer be accurately tested in accordance with the above procedures for determining maximum or in place dry density.

202.3(d) Subgrade Compaction in Cuts.

The finished earth subgrade in cut sections for a width equal to the width of the proposed construction shall be compacted as provided for Standard Compaction, unless Special Compaction is called for in the Contract.

On grading projects where Special Compaction is required, the finished earth subgrade in cut sections to the width above described and to a depth of at least six (6) inches shall be compacted to at least ninety-five (95%) percent of maximum density. Determination of maximum density and attained density in the earth subgrade shall be in accordance with the methods prescribed for Special Compaction.

202.3(e) Riprap Filter Fabric.

The geotextile fabric shall be installed per the construction plan set or as directed by the Engineer in the field.

**202.4 Method of Measurement.**

Fill and select fill materials obtained on site through Excavation Cut will not be measured for payment but will be considered subsidiary to Excavation Cut as specified in Subsection 201.2(a) except that Salvable Crushed Stone, if included in the Proposal as a bid item will be measured in cubic yards in place in its final location by the method of average end areas or other methods acceptable to the engineer.

Fill obtained off-site as borrow shall be measured in cubic yards in place at the borrow site, computed by the method of average end areas with no correction for curvature or in tons based on tickets received by the Engineer for each load.

Select Fill shall be measured in cubic yards or tons, as designated in the Contract, based on tickets received by the Engineer for each load of Select Fill.

Topsoil shall be measured in square yards of actual area which has been topsoiled in the limits of construction or as designated by the Engineer.

Riprap Filter Fabric shall be measured by the square yard in place.

All tickets for materials delivered to a City of Madison project shall be presented to the City representative on the project within twenty-four (24) hours after delivery of the materials to the project. Tickets presented after the time specified may be rejected due to inability to substantiate actual use of the materials on the project. Payment for Fill Borrow per ton or Select Fill will not be made for any amounts not substantiated by a ticket received by the Engineer.

When materials specified to be measured by the cubic yard have been weighed, the weights will be converted to cubic yards for payment purposes. Fill materials will be considered to have a unit weight of 2,835 pounds per cubic yard.

**202.5 Basis of Payment.**

Fill items, measured as provided above shall be paid for at the contract unit price for Fill Borrow, Select Fill, Select Fill [Type], Crushed Stone, Clear Stone, Breaker Run. Such payment shall be considered full compensation for furnishing, hauling, placing, and compacting the specified material, including all equipment, tools, labor and incidentals necessary to complete the work as specified.

Salvable Crushed Stone, measured as provided above shall be paid for at the contract unit price per cubic yard only if the item is included in the Proposal. Such payment shall be considered full compensation for excavating, stockpiling, placing, and compacting the specified material, including all equipment, tools, labor and incidentals necessary to complete the work as specified.

Topsoil, measured as provided above shall be paid for at the contract unit price per square yard. Such payment shall be considered full compensation for furnishing, hauling, placing and fine grading the

## Part II - Earthwork

specified material, including all equipment, tools, labor and incidentals necessary to complete the work as specified.

Geotextile fabric, measured as provided above shall be paid for at the contract unit price per square yard for Riprap Filter Fabric. Such payment shall be considered full compensation for furnishing and installing the fabric, including all equipment, tools, labor and incidentals necessary to complete the work as specified.

## **ARTICLE 203 - REMOVAL OF MISCELLANEOUS STRUCTURES**

---

### **203.1 Description.**

This work shall consist of removing, wholly or in part, pavements, surface and base courses, curb and gutter, sidewalks, crosswalks, driveways, steps, masonry, surface drains, guard rail, fences, poles, buildings, tree grates access structures, catchbasins, inlets, storm and sanitary sewer pipes occurring within the right-of-way, whether specified or subsequently found necessary and required. This work shall also consist of salvaging and disposing of the resulting materials and backfilling the resulting trenches and pits; or, when specified, the abandoning of sewer access points, catchbasins, or inlets by closing, filling or sealing as hereinafter provided.

Removing Pavement shall consist of the removal of Portland cement concrete pavement or base (reinforced and non-reinforced) including all surface or other pavements superimposed thereon.

Removing Concrete Sidewalk shall consist of the removal of concrete sidewalk, crosswalks, and driveways, reinforced and non-reinforced.

Sawing Asphalt Pavement, Full Depth and Sawing Concrete Pavement, Full Depth shall consist of full depth sawing of old, existing, concrete or asphaltic pavement and curb and gutter. Sawcutting concrete curb and gutter, sidewalks and driveways shall be incidental to Remove Concrete Curb and Gutter, Sidewalk and Drive. Full depth sawcuts of concrete pavement shall be made with diamond blades.

### **203.2 Construction Methods.**

#### **203.2(a) Removing Structures.**

All existing structures, with all attached parts and connections, shown on the plans to be removed, or that interfere with the new construction, shall be entirely removed within the limits shown, unless otherwise provided. No equipment or devices shall be used which might damage structures, facilities, or property which are to be preserved and retained. All operations necessary for the removal of any existing structure, which might endanger the new construction, shall be completed prior to the construction of the new work.

All walls, piers, surface drains, foundations and similar masonry structures shall be removed entirely unless otherwise directed by the Engineer.

In removing sewer access structures, catchbasins and inlets, all incoming and outgoing pipes shall be disconnected and any live sewers shall be rebuilt and properly reconnected and a satisfactory bypass service shall be maintained during such construction operations. If the SAS is connected to CIPP, the contractor shall sawcut the host pipe and the liner before removing the existing SAS to avoid shifting. The contractor shall then remove the host pipe to expose the liner. If the liner is damaged during removal of the host pipe, the contractor is responsible for installing a short liner that's compatible with the existing liner in the affected section of pipe after the SAS is installed. Proposed active sewer mains shall remain free of debris or concrete plugs throughout the duration of construction. The void area left from the structure removal shall be backfilled as specified in 203.2(e). Any pipe plugs required shall be incidental to removing the sewer access structure. The structure shall be removed and disposed of by the Contractor at a site to be determined by the



## Part II - Earthwork

Contractor. All castings shall be delivered by the Contractor to the Engineering Service Building storage area at 1602 Emil Street.

Sewer pipe designated for salvage shall be removed, stored, transported and handled in a manner that will preclude damage to the pipes.

When a portion of the existing structure is to be retained, care shall be taken during construction operations so as not to impair the value of the retained portion. Reinforcing bars which are to be left in place so as to project into new work as dowels or ties shall not be injured during removal of the concrete.

In removing pavement, curb, gutter, sidewalk, crosswalks, driveways, steps and similar structures, where portions of the existing structure is to be left in the surface of the finished work, the structure shall be removed to an existing joint, or full depth saw cut and chipped to a true line with a face perpendicular to the surface of the existing structure. Sufficient removal shall be made to provide for proper grades and connections to the new work.

In removing sewer pipe, the work shall include removing the pipe as called out on the plan set. Pipe to be removed that is in the same trench as a new pipe shall not be compensated as remove pipe and shall be considered to be part of the new pipe installation. This includes unidentified pipe that is smaller than 10 inches in diameter.

If the pipe to be removed ends along a pipe run, as opposed to ending at a structure, the Contractor shall end the removal with a saw cut of the existing pipe and plug the remaining end(s) as directed by the Engineer. Plugging the remaining pipe to which the pipe being removed was connected shall be considered incidental to removing the pipe if the pipe is smaller than 10" in diameter. If the pipe is 10" in diameter or larger, plugging the end(s) shall be compensated for under a separate bid item (pipe plug). If the Contractor, for his convenience, decides to remove a section of pipe to a full section, the additional removal shall not be given consideration for additional compensation.

Where existing culverts, sewer access points, catchbasins and similar structures are to be extended or otherwise incorporated in the new work, only such part or parts of the existing structure shall be removed as are necessary to provide a proper connection to the new work. The connecting edges shall be cut, chipped and trimmed to the required lines and grades without weakening or damaging the part of the structure to be retained.

Buildings to be removed shall be razed, all material and debris resulting therefrom disposed of, and any resulting openings backfilled. The building or buildings to be removed will be designated in the contract by a general description and with reference to a survey station. All buildings to be removed and all materials resulting from the razing of buildings shall become the property of the Contractor unless otherwise provided in the contract. The City assumes no responsibility for the condition of any building at any time, and no guarantee is made or implied that any building will remain in the condition the bidder finds it when the building is examined incident to preparing the proposal. The Contractor shall procure all permits necessary for razing and removing buildings, including those necessary where streets or alleys are obstructed by the work. The razing of buildings and the removal of the materials thereof shall be performed in a safe manner and in compliance with the requirements of the Wisconsin Department of Industry, Labor and Human Relations and any applicable City ordinances. Where hazardous conditions are created incidental to the contract operations, the Contractor shall furnish, erect and maintain suitable barricades to protect and safeguard the public. The Contractor shall notify public utility companies and the City Engineer serving the building in

## Part II - Earthwork

sufficient time, prior to razing operations, to permit them to disconnect, plug, and/or remove such of their facilities as may be in the building. Municipal water service lines shall be shut off at the curb boxes and sewer connections shall be tightly plugged or sealed. Unless otherwise provided, the removal of a building shall include the removal of foundation walls and the basement floor. Before backfilling, all debris shall be removed. Holes shall be broken in basement floors to permit drainage.

### 203.2(b) Sawing Asphalt Pavement, Full Depth and Sawing Concrete Pavement, Full Depth.

The sawing operation shall be performed so that the surface to remain is generally vertical for its full depth.

Sawcuts shall not exceed into concrete pavement placed in the work under contract and shall not exceed into existing pavements more than six (6) inches beyond the limits designed by the Engineer.

The sludge from sawing shall be removed from the pavement upon completion of each sawcut by methods which minimize the amount of sludge flowing onto or being deposited on the pavement of any live traffic lane.

The Contractor shall note that it is unlawful to discharge sawcut sludge into lakes, streams, and storm sewer without a DNR permit. Illegal discharge into the storm sewer will not be permitted by the City and is subject to fines imposed by the Wisconsin DNR.

All traffic control devices shall be clean of any sludge deposits by darkness of the day in which the deposition occurs.

### 203.2(c) Abandoning Structures and Pipes.

If the contract calls for abandoning sewer access structures, catchbasins, or inlets, they shall be thoroughly cleaned and the existing pipe connections shall be plugged. Any pipe plugs required to abandon the sewer access structure shall be incidental to abandoning sewer access structures. The roofs of the structure shall be removed. The walls of the structures shall be removed to a depth of two feet or more below the finished grade. The void area left from the structure that was abandoned shall be backfilled as specified in 203.2(e).

Abandoning pipe with slurry shall require the entire pipe be filled with slurry. Vent holes may be required by the Engineer to verify there are no voids left in the pipe. Sawcutting and removal of the existing pipe at the limits of abandonment shall be included in this item. The slurry shall conform to Type B Slurry Mix as specified in Section 301.9 of these specifications.

Pipe shall be abandoned by plugging the end(s) of the pipe and shall be compensated for as pipe plug(s) if over 10" in diameter.

Abandoned pipes or pipes to be abandoned that are encountered in a trench while installing or removing pipes shall be plugged per this section. If the abandoned pipe is less than ten (10) inches, plugging the pipe shall be considered incidental to installing or removing or abandoning sewer pipes.

Service shall be maintained in existing sewers until the replacement sewers or appropriate bypasses approved by the Engineer have been installed, at such time bulkheads or plugs may be placed.

Contractor shall contact and coordinate with other utilities so that they may plug their own facilities.

**203.2(d) Disposing of Materials.**

All materials having salvage value shall be carefully removed to avoid damage and shall be disposed of as follows:

1. Sewer access structures, catchbasin and inlet castings shall be hauled to the Engineering Service Building storage yard at 1602 Emil Street.
2. All privately owned corrugated culverts shall be placed on the owner's property at the time of grading.
3. All City owned pipe shall be hauled to the Engineering Service Building storage area at 1602 Emil Street.
4. All concrete, stone, brick and other materials shall be disposed of by the Contractor at a site to be furnished by the Contractor at no cost to the City.
5. All existing tree grates shall be carefully removed and delivered to the City of Madison Parks Division at 4600 Sycamore Avenue. The Contractor shall notify City Forestry, City of Madison, (608) 266-4891 to schedule delivery.

**203.2(e) Backfilling.**

All trenches, holes and pits resulting from the removal or abandoning of pipe and other miscellaneous structures shall be filled with satisfactory soil or select fill, placed in layers not more than twelve (12) inches in thickness. Select backfill shall be required for any structure or pipe within the roadway that will not be filled with another structure or pipe. All fill material required shall be considered incidental to the removal or abandonment. Each layer shall be thoroughly compacted by means of approved tampers, rollers or vibrators. Water shall not be used to expedite settlement of backfill except with the approval of the Engineer; this provision shall not be construed to require an excavation to be dewatered before placing backfill, if backfilling can be performed in such manner as to displace the water or prevent its entrapment in the backfill.

Unless otherwise provided in the contract, backfilling shall be made to the elevation of the natural ground, the proposed finished earth subgrade or finished slopes, as may be necessary due to the location of the removed structure.

**203.3 Method of Measurement.**

Unless otherwise provided, this work will be measured in the original position of the structures to be removed, as follows:

1. Removing concrete pavement will be measured by area in square yards irrespective of the depth or number of courses encountered. Where removing concrete pavement consists of a rigid base having an asphalt surface extending beyond the lateral limits of the rigid base, such as a widened pavement, only the area occupied by the rigid base will be measured as removing concrete pavement, and that portion of the asphalt surface beyond the rigid base shall be removed and will be measured as Excavation Cut.

## Part II - Earthwork

2. The removal of flexible bases or portions thereof will be measured as Excavation Cut.
3. Removing curb and gutter will be measured by length in linear feet, taken along the flow line of gutter for gutter or curb and gutter, and along face of curb for curb.
4. Removing sidewalk, crosswalks and driveways will be measured by area in square feet.
5. Removing steps shall be measured as the summation of the areas of the treads, computed by multiplying the width of the tread by the length of the tread out to out of integral wall, if any.
6. Removing guard rail will be measured by length in linear feet and including end sections or anchorages.
7. Removing surface drains will be measured as units.
8. Removing fence will be measured by length in linear feet.
9. Removing utility poles, pole stubs, access structures, catchbasins and inlets will be measured as units, including all attached parts and connections.
10. Removing building will be measured as a unit for each specified building removed.
11. Removing sewer pipes shall be measured by length in feet.
12. Abandoning access structures, catchbasins, or inlets will be measured by units.
13. Sawcutting will be measured in linear feet.
14. Abandon sanitary sewer pipe with slurry shall be measured by the cubic yard of slurry required to completely fill the void. Payment quantity shall not exceed the calculated void area.
15. Pipe plug shall be measured as a complete unit for every pipe opening plugged as described above.
16. Sawing asphalt pavement full depth and sawing concrete pavement, full depth, shall each be measured by the lineal foot of completed and accepted work. Overcuts beyond the limits shown on the plans or directed by the Engineer will not be measured for payment.
17. Removing Tree Grate shall be measured by the unit each removed.

### **203.4 Basis of Payment.**

The contract price for removing or abandoning pipe and other miscellaneous structures, as the case may be, shall be payment in full for sawcutting, trimming and chipping; for breaking down, removing, or sealing; for cutting, protecting or removing reinforcing steel, if any, as required; for procurement of any required work permits; for disposal of materials; for backfilling; for furnishing any required concrete masonry; and for furnishing all labor, tools, equipment and incidentals necessary to complete the item of work in accordance with the requirements of the contract.

## Part II - Earthwork

If the contract does not include a separate item for removal or abandonment of miscellaneous pipes, the removal or abandonment of existing miscellaneous pipes shall be considered incidental to other items of work and there shall be no payment for their removal.

Sawcutting, measured as provided above, shall be paid for at the contract unit price bid for sawcutting, which price shall be payment in full for acquiring all permits, furnishing all labor, tools, equipment and incidentals necessary to complete the item of work in accordance with the requirements of the contract.

The contract price for pipe plug shall include all labor, materials and incidentals to install a twelve (12) inch thick minimum bulkhead that covers the entire opening. The pipe plug shall consist of either mortared concrete brick or block; concrete of the class and grade specified for structures; or as specified on the plans. The Engineer may require pipes larger than thirty (30) inch diameter to be abandoned with concrete and reinforced bars. The method of construction shall be approved by the Engineer.

Removing Tree Grate, measured as provided above, shall be paid at the contract unit price for work as described above.

No additional compensation shall be made for the removal of concrete encased sewer pipe.

When there is no unit price for Concrete Pavement Removal in the contract, it shall be understood and agreed that the contractor shall be paid \$5.00 per square yard of concrete pavement removed. The void shall be backfilled with select fill and paid for under the appropriate bid item.

## **ARTICLE 204 - CLEARING AND GRUBBING**

---

### **204.1 Description.**

Clearing and Grubbing shall consist of cutting and disposing of trees and the removing and disposing of stumps, where designated on the plan or directed by the Engineer.

Trees under three (3) inches in diameter, shrubs, brush, windfalls, logs and other vegetation within the right-of-way, where designated on the plan or directed by the Engineer, shall be removed at the Contractor's expense.

### **204.2 Construction Methods.**

Where trees cannot be felled without danger to traffic or injury to other trees, structures, or property, they shall be cut in sections from the top down.

All desirable and structurally sound trees, saplings, or shrubs suitable for shade or street beautification purposes shall be saved unless otherwise ordered by the Engineer. Trees, saplings, and shrubs designated to be left in place shall not be damaged or injured by the Contractor. The absence of specific orders to remove trees, saplings, or shrubs shall be considered as orders to save the trees, saplings, or shrubs. Trimming of limbs of trees or saplings or trimming of shrubs shall not be done without the permission of the Engineer.

All tree stumps shall be completely removed by excavation under proposed concrete sidewalk, concrete curb and gutter, all types of pavement, permanent structures, and at such other places as directed by the Engineer. In street terraces, boulevards and tree grate locations, tree stumps shall be ground to a depth of at least twenty-four (24) inches. Tree stumps under other areas in the right-of-way may be removed with stump cutting machinery to a depth of at least twelve (12) inches below the original ground area in fill areas, and at least twelve (12) inches below the subgrade in cut areas.

The Contractor shall provide a disposal area for all trees, stumps, limbs, brush and vegetation from the project at no additional cost to the City.

Stumps, roots, brush, logs, limbs, and other debris resulting from clearing and grubbing shall not be burned on or near City property without the written permission of the Engineer, and the securing of permits for burning from the proper authorities.

### **204.3 Method of Measurement.**

The quantity of Clearing or of Grubbing will be measured per inch diameter of tree or stump approximately 4-1/2 feet above the existing ground level but above the ground swell, and the diameter of the tree or stump shall be 1/3 of the measured circumference. The measurement for circumference and determination of diameter will be to the nearest full inch. Only trees or stumps in place, the circumference of which is nine (9) inches or more will be measured for payment.

### **204.4 Basis of Payment.**

The contract unit price for Clearing or for Grubbing, per inch diameter, shall be payment in full for furnishing all labor and equipment for all clearing and grubbing actually required and performed, and the handling and disposal of all debris resulting from clearing and grubbing.

## **ARTICLE 205 - ADJUSTMENT OF CASTINGS**

---

### **205.1 General.**

The Contractor shall adjust all existing access structure frames, catchbasin frames, water and gas main valve boxes, water and gas service shutoff valve boxes, and lamp holes to the finished grade of the pavement, curb and gutter, terraces, sidewalks, and drive approaches. The Contractor shall notify the private and public utilities (water, gas, electric, telephone, cable television, Traffic Engineering, etc.) prior to commencing work on the project in order to allow the various utilities to locate and mark their facilities. The various utilities may bring main valve boxes and service shutoff valve boxes to grade, and they may adjust their access structure castings to grade, at the request of the Contractor. The Contractor shall make those adjustments not made by the various utilities. The Contractor shall furnish and maintain the necessary protection for the access structure frames, catchbasin frames, water and gas main valve boxes, water and gas service shutoff valve boxes and lamp holes to prevent damage either to the castings or to persons or property or others allowed to pass through the construction area. Upon completion of the work on the project, the various utilities will be notified to inspect, adjust and repair their facilities as required. The Contractor will be responsible for any damage to access structure frames, catchbasin frames, water and gas main valve boxes, water and gas service shutoff valve boxes, and lamp holes, and any costs of repair will be deducted from any payments made to the Contractor.

### **205.2 Construction Methods.**

Adjusting sewer access structures and catch basin frames includes removing the existing casting; removing the existing adjusting blocks, bricking or rings to a sound brick, block, concrete barrel section or concrete roof base; installing new adjusting blocks, bricking, or rings to the required elevation; and reinstalling the existing casting to the rim elevation as indicated on the plan set or as directed in the field. The existing adjustments shall be disposed of off-site by the Contractor at a site to be determined by the Contractor. New adjusting blocks, bricking or rings shall be of solid concrete and shall be in accordance with the requirements of Standard Plate 5.7.15. Any "pin" type castings shall be removed and disposed of by the Contractor. If a new City of Madison Standard casting is required, one shall be salvaged from another structure on the job site designated for removal or if no acceptable castings are available on site, City Engineering shall provide one.

If a new cone section is required to maintain less than 9 (nine) inches of adjusting rings, the contractor shall be paid for Adjust Sewer Access Structure, Bid Item 20501, contractor shall not be paid for Adjust Sewer Access Structure Casting, Bid Item 20506.

The finished top elevation of castings in the paved area of streets shall be set with a string line at least forty (40) feet long set over the casting parallel to the street direction at the proposed finished grade of the street.

All salvaged castings shall be the property of the City. The Contractor shall haul such replaced castings to the Engineering Service Building storage area at 1602 Emil Street and deposit the castings as directed by the person in charge of the storage area.

Unless otherwise specified, the City shall furnish the new castings. The City shall issue replacement castings upon receipt of the Contractor's written request and the Inspector's certification. Replacement castings for storm and sanitary sewers shall be issued from the casting storage at the Engineering Service Building, 1602 Emil Street; the Contractor shall notify the Engineering Service

Building at telephone number 266-4430 at least one day in advance when new castings are required. Replacement castings for Water Utility access structures shall be issued from the casting storage at the Water Utility Operations Center, 110 South Paterson Street; the Contractor shall notify the Water Utility Operations Center at telephone number 266-4661 at least one day in advance when new castings are required. Replacement castings for Traffic Engineering electrical utility access structures shall be issued from the casting storage at the Traffic Engineering Shop, 1120 Sayle Street; the Contractor shall notify the Traffic Engineering Shop at telephone number 266-4767 at least one day in advance when new castings are required. The Contractor shall furnish all labor and equipment to load, transport and unload the castings from the site of the casting storage to the job site.

All castings shall be set to final grade prior to placement of the asphaltic lower layer.

### **205.3 Measurement and Payment.**

The adjustment and protection of water and gas main valve boxes and water and gas service shutoff valve boxes shall be considered incidental to the work, and no compensation will be made for their adjustment and protection, unless otherwise specified.

The adjustment of access structure, catchbasin and castings shall be measured as units of each, and all costs, including labor, materials (except castings), loading, transporting and unloading both existing and replacement castings as specified in Section 205.2 above, disposal of materials, and incidentals necessary to complete the work shall be included in the unit prices bid for adjusting access structure castings or for adjusting catchbasin castings, as the case may be. Castings having an opening with an inside dimension of over twenty-four (24) inches shall be considered catchbasin castings.

When the adjustment of access structure and catchbasin castings are not listed in the proposal as items on which to submit unit prices, the City will pay the Contractor for each such adjustment at the rate of \$150.00 for each access structure casting adjusted, or \$200.00 for each catchbasin casting adjusted, plus \$20.00 per vertical inch for each inch of adjustment per casting in excess of six (6) inches, either up or down. These costs do not include the costs of castings.

The costs of adjustment of all access structure and catchbasin castings installed on new access structures and catchbasins which are constructed as a part of the project shall be included in the unit prices bid for the structures involved.



## **ARTICLE 206 - OBLITERATING STREET**

---

### **206.1 Description.**

Obliterating Street shall consist of grading portions of the street that are required to be abandoned, and shall include scarifying or plowing areas of the old roadway. It shall include the removal and disposal of all types of surfacing including removal of Portland cement concrete pavement, brick pavement and rigid base courses.

The removal and disposal or salvage of old bridges shall not be included under Obliterating Street.

When removal and disposal or salvage of miscellaneous structures within the limits of Obliterating Street is not covered by separate bid items, such work shall be included under Obliterating Street.

Seeding shall not be included under Obliterating Street.

Obliterating Street shall apply only to those portions of the street designated for obliteration.

### **206.2 Construction Methods.**

The ditches shall be filled and the roadway graded, either to approximately restore the original contour of the ground or to produce a contour which will merge with the contour of the adjoining land. Where feasible, waste material shall be placed in cuts on the old road.

Pavements, curb and gutter, and similar rigid structures, for which no separate provision for disposal is included in the contract shall be removed.

Old road surfacing of gravel, crushed stone and other nonrigid type, for which no separate provision of salvage or disposal is included in the contract and when underlying the proposed finished surface by less than one foot, shall be scarified or plowed to effectively mix the material with soil, or where feasible such surfacing material shall be bladed into the old ditches and covered with suitable soil.

Rocks, boulders and surface stone encountered in the work shall be removed and disposed of. Stones of greater than six (6) inch size shall be placed not less than six (6) inches below the proposed finished surface, and within areas suitable for cultivation all stone shall be kept to a reasonable minimum in the upper eight (8) inches of completed embankment.

Clearing and grubbing necessary to properly obliterate the street shall be construed to be a part of the item of Obliterating Street.

After the rough grading is completed, the obliterated street shall be topsoiled. Upon completion of necessary topsoiling, the entire area of the old roadway as obliterated shall be harrowed, smoothed and seeded.

Material with salvage value shall be removed to avoid damage.

### **206.3 Method of Measurement.**

Obliterating Street will be measured by length along the old street center line in stations of 100 feet and fractions thereof.

The removal of specific miscellaneous structures, when a bid item under the contract, will be measured as provided under Article 203, Removal of Miscellaneous Structures.

Seeding will be measured as provided under Article 207, Seeding.

**206.4 Basis of Payment.**

The item of Obliterating Street will be paid for at the contract unit price per station, which price shall be payment in full for all work specified herein, except as follows:

If the contract includes separate items for removal of specific miscellaneous structures, such removal will be paid for separately.

The item of Seeding will be paid for separately as provided in Article 207, Seeding.

## ARTICLE 207 - SEEDING

### 207.1 Description.

This work shall consist of preparing seed beds, furnishing and sowing the required seed, furnishing and applying the required stabilizers, fertilizer, and mulching material on shoulders, slopes, pipe trenches, appurtenances and other areas, as shown on the plans or designated in the contract, or as ordered to be seeded by the Engineer, all in accordance with the requirements of these Specifications.

Trench restoration shall include segregation of topsoil during the pipe installation for re-use as a seed bed, the creation of the seed bed and seed, fertilize and mulch of the pipe trench area. Salvaged topsoil shall be placed in the pipe trench area for restoration to a thickness of 4 inches.

### 207.2 Materials.

#### 207.2(a) Seed.

All seed shall conform to the requirements of the Wisconsin Statutes regarding noxious weed seed content. No seed shall be used on the work later than one year after the germination test date which appears on the label.

Seed shall be tested when required in accordance with the methods and procedures used in making purity analyses and germination tests as adopted by the U.S. Department of Agriculture in the Administration of the Federal Seed Act.

Seed Mixtures:

1. **Terrace Seed Mixes (Sun and Shade).** Seed for terrace seed mixes shall be clean, latest crop seed of the varieties required, labeled in accordance with U.S. Department of Agriculture Rules and Regulations under the Federal Seed Act in effect at the time of delivery of seed. Seed shall be properly mixed. The seed shall be delivered in sealed containers to which is affixed a statement of guaranteed analysis for each seed variety furnished. Seed shall meet the following requirements and shall be subject to test at the expense of the owner by the State Seed Laboratory of the Wisconsin State Department of Agriculture.

<b>SUN TERRACE MIX</b>			
<b>Formulation</b>	<b>Variety</b>	<b>% Purity</b>	<b>% Germination</b>
30%	Dawson Red Fescue	95	85
30%	Puccinella Distans	99	85
30%	Geronimo Kentucky Bluegrass	95	85
10%	SR 4000 Perennial Rye Grass	98	90

<b>SHADE TERRACE MIX</b>			
<b>Formulation</b>	<b>Variety</b>	<b>% Purity</b>	<b>% Germination</b>
60%	Creeping Red Fescue	95	85
30%	Glade Kentucky Bluegrass	99	85
10%	SR 4000 Perennial Rye Grass	98	90

Part II - Earthwork

2. **Infiltration Seed Mix.** Seed shall be native ecotypes. No improved varieties are allowed. Seed source shall be native ecotypes from Southeast Minnesota, Eastern Iowa, Southern Wisconsin, or Northern Illinois.

VARIETY	% BY WT.
<b>FORBS (22.75%)</b>	
Aster novae-angliae (New England Aster)	1.31
Cassia Hebecarpa (Wild Senna)	3.27
Eupatorium maculatum (Joe Pye Weed)	1.31
Helenium Autumnale (Sneezeweed)	1.31
Liatris pycnostachya (Prairie Blazing Star)	2.62
Lobelia Siphilitica (Great Blue Lobelia)	0.82
Pedicularis lanceolata (Marsh Betony)	1.31
Rudbeckia hirta (Black-eyed Susan)	1.31
Rudbeckia triloba (Brown-eyed Susan)	2.62
Silehium perforliatum (Cup Plant)	1.64
Solidago riddellii (Riddell's Goldenrod)	1.31
Verbena hastata (Blue Vervain)	0.65
Vernonia fasciculata (Common Ironweed)	1.31
Zizia aurea (Golden Alexanders)	1.96
<b>GRASSES, SEDGES &amp; RUSHES (77.25%)</b>	
Andropogon Gerardii (Big Bluestem PLS)	52.37
Elymus Canadensis (Canada Wild Rye PLS)	10.47
Elymus virginicus (Virginia Wild Rye PLS)	10.47
Panicum virgatum (Switch Grass PLS)	2.62
Scirpus atrovirens (Dark-green Bulrush)	1.31

3. **Detention Basin Seed Mix.** Seed shall be native ecotypes. No improved varieties are allowed. Seed source shall be native ecotypes from Southeast Minnesota, Eastern Iowa, Southern Wisconsin, or Northern Illinois.

VARIETY	% BY WT.
<b>FORBS (42.86%)</b>	
Sweet Flag	1.43
Mud Plantain	.71
Nodding Onion	1.43
Canada Anemone	.36
Swamp Milkweed	5.00
New England Aster	.71
Flat-topped Aster	.34
False Aster	.34
Turtlehead	.57
Joe Pye Weed	.57
Boneset	.34
Cream/Bottle Gentian Mix	.71
Sneezeweed	.71
Early Sunflower	.71
Rose Mallow	2.86

Part II - Earthwork

<b>VARIETY</b>	<b>% BY WT.</b>
Southern Blue Flag	2.86
Prairie Blazing Star	3.57
Great Blue Lobella	.71
Marsh Betony	.71
Obedient Plant	.71
Mountain Mint	.71
Black-eyed Susan	1.43
Sweet Black-eyed Susan	.36
Brown-eyed Susan	1.43
Compass Plant	2.86
Cup Plant	1.43
Prairie Dock	2.14
Riddell's Goldenrod	.71
Bog Goldenrod	.34
Purple Meadow Rue	2.14
Blue Vervain	.71
Common Ironweed	1.43
Culver's Root	.34
Golden Alexanders	1.43
<b>GRASSES (57.4%)</b>	
Big Bluestem	8.57
American Sloughgrass	7.71
Fringed Brome	5.14
Blue Joint Grass	.34
Bebb's Oval Sedge	1.43
Bristly Sedge	1.43
Porcupine Sedge	1.43
Common Hop Sedge	1.43
Common Fox Sedge	1.43
Brown Fox Sedge	1.43
Canada Wild Rye	5.14
Virginia Wild Rye	5.14
Reed Manna Grass	1.43
Common Rush	.71
Inland Rush	.29
Switch Grass	1.43
Dark-green Bulrush	.71
Wool Grass	.37
Great Bulrush	.71
Indian Grass	9.43
Cord Grass	1.43

Part II - Earthwork

4. **Tall Grass Prairie Mix.** Seed shall be native ecotypes. No improved varieties are allowed. Seed source shall be native ecotypes from Southeast Minnesota, Eastern Iowa, Southern Wisconsin, or Northern Illinois.

<b>VARIETY</b>	<b>% BY WT.</b>
<b>FORBS (50%)</b>	
Smooth Blue Aster	.85
New England Aster	.85
Canadian Milk Vetch	.43
White Wild Indigo	5.11
Pale Indian Plantain	1.70
Rattlesnake Master	7.62
Biennial Gaura	3.40
Cream Gentian	.85
Early Sunflower	1.70
Great St. John's Wort	.85
Prairie Blazing Star	5.11
Wild Bergamot	.85
Foxglove Beardtongue	.85
Yellow Coneflower	1.70
Black-eyed Susan	1.70
Sweet Black-eyed Susan	.43
Brown-eyed Susan	3.40
Compass Plant	5.11
Stiff Goldenrod	.85
Showy Goldenrod	.43
Purple Meadow Rue	3.40
Golden Alexanders	2.81
<b>GRASSES (50%)</b>	
Big Bluestem	18.72
Canada Wild Rye	12.50
Switch Grass	1.70
Indian Grass	15.37
Cord Grass	1.70

5. **No Mow Turf.** Unless specified otherwise, Contractor shall supply the No Mow with annual rye variety. The following formulation is as manufactured by the Prairie Nursery of Westfield, Wisconsin. Any substitution must have prior approval of the Engineer.

<b>NO MOW</b>	<b>ORIGIN/GERM</b>
SR5130 Chewings Fescue-Festuca commutata-24.74%	OR-85%
Sheep Fescue-Festuca Ovina-24.42%	Canada-85%
Chariot Hard Fescue-Festuca longifolia-12.44%	OR-85%
Heron Hard Fescue-Festuca rubra-12.35%	OR-85%
Sea Link Creeping Red Fescue-Festuca rubra-12.31%	OR-85%
SR5250 Creeping Red Fescue-Festuca rubra-12.17%	OR-85%

1.55% Inert matter

Part II - Earthwork

.01% other crop seed  
 0.1% Weed Seed  
 Noxious Weed Seed-None

<b>NO MOW WITH ANNUAL RYE</b>	<b>ORIGIN/GERM</b>
SR5130 Chewings Fescue-Festuca commutata-23.75%	OR-85%
Sheep Fescue-Festuca Ovina-23.44%	Canada-85%
Chariot Hard Fescue-Festuca longifolia-11.94%	OR-85%
Heron Hard Fescue-Festuca rubra-11.85%	OR-85%
Sea Link Creeping Red Fescue-Festuca rubra-11.82%	OR-85%
SR5250 Creeping Red Fescue-Festuca rubra-11.68%	OR-85%
Annual Ryegrass-Lolium multiflorum-3.95%	OR-90%

1.53% Inert matter  
 .02% other crop seed  
 .02% Weed Seed  
 Noxious Weed Seed-None

6. **Storage of Seed.** Any seed delivered prior to use shall be stored in such manner that it will be protected from damage by heat, moisture, rodents or other causes. Any previously tested and accepted seed that has become damaged shall be discarded and replaced by the Contractor.

207.2(b) Fertilizers.

Fertilizers, intended for use in connection with seeding, sodding, or other planting, shall be standard commercial products conforming to the requirements of the Wisconsin Statutes. Native plant seedings or temporary seeding to be followed by native seedings should not be fertilized. Each package of fertilizer shall be plainly marked with the analysis of the phosphoric acid and soluble potash. Fertilizers shall meet the following minimum requirements:

Nitrogen, not less than ..... 10%  
 Phosphoric Acid, not less than ..... 10%  
 Potash, not less than ..... 10%

207.2(c) Mulching Material.

Mulching material shall consist of any straw, hay, wood excelsior fiber or other suitable material of a similar nature which is substantially free of noxious weed seeds and objectionable foreign matter.

Asphalt material, if used, shall be an emulsified asphalt meeting the requirements for the Type SS-1 of the Specifications for the Emulsified Asphalt, AASHTO Designation: M 140.

207.2(d) Soil Stabilizers.

Soil stabilizers are intended as soil bonding agents to prevent or minimize erosion. They must be environmentally benign; harmless to fish, wildlife, and plants; along with being non-toxic and non-combustible at the rate of application specified by the manufacturer. Asphalt based products will not be approved for use. Only products approved for field testing, and field tested by Wisconsin Department of Transportation will be approved for use. Soil stabilizers are considered a short term

duration (6 months) erosion control device for use on slopes 3:1 or flatter. In addition to the above requirements soil stabilizers must meet the same vegetative density and sediment loss standards as required for erosion mats.

Soil Stabilizer, shall be a polyacrylamide (PAM) and calcium solution intended to reduce the erodability of bare soils during construction activities or to enhance the performance of mulching on permanent slopes. Polyacrylamide Soil Stabilizer shall have proven abilities to bond soil particles, effectively increasing the soil particle size to 1.0 millimeter or larger. It shall reduce the movement of soil through chemical bonding, increase the particle size thus making silt fence more effective, and increase the water absorption of the soil.

Polyacrylamide Soil Stabilizers shall conform to the Wisconsin Department of Transportation's Product Acceptability List (PAL) for Soil Stabilizers, Type B. Presently, the only acceptable product is Natural Earth PolyStable Plus manufactured by Earth & Road.

**207.3 Construction Methods.**

207.3(a) Seeding – Turf/Native.

The seed mixes shall be applied at the following rates:

Seed Mix	Rate
Terrace (Sun & Shade)	3.5 lbs per 1000 s.f.
Infiltration	7.64 lbs per acre
No Mow Turf	5.00 lbs per acre
Detention	9.53 lbs per acre
Tall Grass Prairie	8.00 lbs per acre

Native seeding for mixes not listed in Section 207.3(a) shall be in accord with the rates in 207.2(a) and the cover crop requirements in 207.3(b).

The Contractor shall repair all damaged or eroded areas as necessary and reseed during the required maintenance period.

Unless otherwise specified the Engineer shall specify in the field the use of Sun or Shade Terrace mix based on the project location.

Seeding shall be limited to the following period only:

Standard Turf - April 15 to September 15th and after October 15th to snow cover.

Native Seeding - May 1 to June 30th and after October 15th to snow cover.

Seeding of turf beyond October 15th shall be at the discretion of the Engineer and shall include an addition to the seed mix of a companion crop as specified below under Cover Crops and Temporary Seeding 207.3(b). Seeding of all native varieties requires the use of Cover Crops and Temporary Seeding see 207.3(b).

Any seeding outside the dates listed above shall be at the risk of the Contractor and reseeding after October 15th or in the spring shall be completed at no additional cost to the City of Madison with the same seed mix that was specified in the contract.



Part II - Earthwork

Grading, shouldering, topsoiling, and fertilizing shall be completed before seeding, except that when equipment designed for the purpose is used, the fertilizer and seed mixture may be placed in one operation. The areas to be seeded shall be worked with discs, harrows or other appropriate equipment until it becomes a reasonably even and loose seed bed immediately in advance of the seeding.

Unless otherwise specified, seed may be sown at the option of the Contractor, by either Method A or Method B described below.

1. Method A. The seed mixture shall be sown by means of equipment adapted to the purpose, or it may be scattered uniformly over the areas to be seeded, and lightly raked or dragged to cover the seed with approximately one-fourth inch of soil. After seeding, the areas shall be lightly rolled or compacted by means of suitable equipment, preferably of the cultipacker type when such equipment can be operated, or by means of light hand tampers.
2. Method B. Upon the prepared seed bed, the seed shall be sown or spread by means of a stream of spray of water under pressure operated from an approved type of machine designed for that purpose. The selected seed mixture and water shall be placed into a tank, provided within the machine, in sufficient quantities that when the contents of the tank are sprayed on a given area the seed will be uniformly spread at the required rate of application. During the process the contents of the tank shall be kept stirred or agitated to provide uniform distribution of the seed.
3. Scattering seed by hand shall be done only with satisfactory hand seeders and only at such times when the air is sufficiently quiet to prevent seeds from blowing away.

207.3(b) Cover Crops and Temporary Seeding.

Temporary seeding stabilizes disturbed areas with fast growing annual grasses, small grains, or legumes until permanent vegetation can be established.

In situations where establishment is more difficult or when specified, cover crops shall be used in addition to the permanent seed mix.

Type of Cover	Min. Seed Rate for Temp. Seeding	Min. Seed Rate for Cover Crop
Seed Oats	3 lbs per 1000 s.f.	1.5 lbs per 1000 s.f.
Regreen		
Winter Wheat	3 lbs per 1000 s.f.	1.5 lbs per 1000 s.f.

207.3(c) Fertilizing.

Fertilizer shall be applied at the rate of seventeen (17) pounds per 1,000 square feet of area for areas seeded with terrace seed mix, unless otherwise specified in the contract. Those areas which are specified for temporary seeding shall have fertilizer applied at the rate of ten (10) pounds per 1,000 square feet of area unless otherwise specified in the contract. No fertilizer shall be applied with native plant seedings.

The fertilizer for the seeding areas shall be uniformly spread thereon and incorporated into the soil by light discing and harrowing. The fertilizer shall be pulverized and free from lumps when applied.

## Part II - Earthwork

In the event fertilizer is incorporated with topsoiled areas, the fertilizer may be applied just prior to and in conjunction with the final discing or harrowing operations of the topsoil, or in the event the topsoil is manipulated by hand, just prior to the final raking and leveling.

In the event fertilizer is to be placed on surfaces on which no topsoil is placed, the soil shall be prepared by discing or harrowing to a depth of three (3) to four (4) inches and the fertilizer then incorporated as set forth above.

In the event fertilizer is to be placed on seeding areas where the seed is to be sown by means of a spray or stream of water under pressure, the required amount of fertilizer may be placed in the tank, mixed together with the water and the seed, applied in the seeding operation. Fertilizer applied by this method will not require discing and harrowing after being placed.

### 207.3(d) Mulching.

Mulch shall be placed on those areas which are specified for permanent seeding within three (3) days after the seeding has been completed unless the area is specified to receive erosion matting. Mulch is not required in areas to receive erosion matting provided matting is placed within three (3) days of seeding.

Mulching operations shall not be performed during periods of excessively high winds which would preclude the proper placing of the mulch.

The placed mulch shall be loose enough to allow some sunlight to penetrate and air to slowly circulate but thick enough to shade the ground, conserve soil moisture and prevent or reduce erosion.

The Contractor shall maintain the mulched areas and shall repair any areas damaged by wind, erosion, traffic, fire, or other causes prior to final or partial acceptance of work under the contract.

The Contractor shall perform the work with either Method A or Method B, at the direction of the Engineer.

1. Method A. The mulching material shall be uniformly spread over the designated areas to a loose depth of one (1) to two (2) inches, using seventy (70) to ninety (90) pounds of mulch per 1,000 square feet. The mulch material from compacted bales shall be well loosened or made fluffy before being spread in place. Unless otherwise directed, mulching operations shall begin at the top of the slopes and proceed downward.

The mulch cover, except when composed of wood excelsior fiber, shall be securely anchored in place by means of heavy twine fastened by pegs or staples to form a grid of from six (6) to ten (10) feet spacing.

2. Method B. Straw or hay shall be treated with asphalt material blown from a machine, and uniformly deposited over designated areas in one operation.

The mulch shall be placed uniformly over the area to a loose depth of one (1) to two (2) inches, using one and one-half to two tons of mulch per acre and 75 to 100 gallons of emulsified asphalt per ton of straw or hay. Within the above designated limits, the Engineer will determine, on the job, the rate of application of the mulch and the asphalt, and the right

## Part II - Earthwork

is reserved for the Engineer to vary the rates during mulching operations to produce the desired results.

The machine for placing the mulch shall be of an approved type, which will blow or eject by constant air stream a controlled amount of mulch and which will introduce into the air stream a spray of asphalt to partially coat the straw or hay, producing a spotty tack sufficient to hold together and retain in place the deposited straw or hay.

Wood fiber shall be applied in the same manner as straw or hay except that the wood excelsior fiber shall not be treated with asphalt material.

Throughout the process, the mulch material shall be fed into the blowing machine to produce a constant and uniform ejection from the discharge spout, operated in a position to produce a mulch of uniform depth and coverage.

The mulch material shall not contain moisture in excess of that which will permit uniform feeding through the machine.

### 207.3(e) Watering.

All seeded areas shall be watered as necessary to meet germination and seed growth as defined in 207.4(a) Acceptance and 207.4(b) Guarantee.

The Contractor shall be permitted to delay seeding only when the City of Madison is classified by the U.S. Drought Monitor as D-3 Drought Extreme Status. In these circumstances, the Contractor must seed within 10 days of the end of the D-3 Drought Extreme classification. During this time, the Contractor is required to maintain erosion control until seeded areas are accepted as defined in 207.4(a) Acceptance.

Weekly updates provided by the U.S. Drought Monitor are available at:

[http://droughtmonitor.unl.edu/DM\\_state.htm?WI,MW](http://droughtmonitor.unl.edu/DM_state.htm?WI,MW)

### 207.3(f) Soil Stabilizers.

Soil stabilizers shall be used on all areas seeded.

Application is intended to be done with conventional hydraulic seeding equipment. Polyacrylamide Soil Stabilizer may also be placed through dry spreading. Application rates shall be as recommended by the manufacturer and shall meet the approval of the engineer. In general, rate of application shall be 20 lbs per acre (0.46 lbs per 1000 s.f.).

Where soil stabilizers are used in the terrace or near any other pedestrian walk areas the sidewalk and/or pedestrian walk areas shall be protected to keep the soil stabilizers from being deposited on them. After getting wet, any soil stabilizers on these surfaces can result in a slipping hazard. If soil stabilizers are deposited on a sidewalk the contractor shall clean the sidewalk sufficiently to remove the soil stabilizers. The Contractor shall be aware that conventional methods (sweeping) will not be sufficient to remove the polymer due to the nature of the polymer and other methods (vacuum) will be required to meet this requirement.

## **207.4 Acceptance and Guarantee.**

### **207.4(a) Acceptance.**

Upon completion of seeding, the Contractor shall request approval from the Engineer for acceptance of seeded areas for the purposes of issuing the certificate of completion and removal of erosion control devices (including but not limited to inlet protection, silt sock and/or silt fence, turbidity barrier and/or silt curtain). If the certificate of completion is authorized by the Engineer with pending or without acceptance of seeded areas, the Contractor is responsible for maintaining erosion control devices until authorized by the Engineer.

Acceptance shall be defined as healthy and flourishing germination of 95% of perennial grass seed to a minimum height of 1 inch, with no or few bare patches.

All seeded areas which are dead or found not to be in a normal, healthy condition or do not conform to the specifications, in the judgment of the Engineer will not be accepted. All rejected work shall be replaced by the Contractor, including removal and repair of all work affected by the replacement, at no cost to the City.

### **207.4(b) Guarantee.**

All areas that have been seeded with turf shall be guaranteed to be in a healthy and flourishing condition as defined in section 207.4(a) Acceptance for a period of 1 year from the date on the certificate of completion.

At any time within the period of the guarantee, the Contractor shall replace any seeded areas which for any reason, have died or are in a dying condition, or which have failed to flourish in such a manner or to such a degree that their usefulness or appearance has been impaired. Replacement shall include removal and repair of all affected work. Seeded areas that have perished for any reason shall be reseeded or overseeded with the exact variety of turf seed that was originally specified.

Following the completion of the repair, a re-inspection will be made prior to final acceptance.

## **207.5 Method of Measurement.**

### **207.5 (a) Seeding.**

The item of Seeding will be measured by the square yard or by the trench foot. The quantity to be measured for payment shall be the actual number of square yards of area or the lineal feet of trench which has been seeded in accordance with the contract, within the limits designated on the plans or in the contract or as ordered by the Engineer.

## **207.6 Basis of Payment.**

### **207.6 (a) Seeding.**

Seeding, measured as provided above, will be paid for at the contract unit price per square yard of Seeding, or the trench foot of Seeding, which price shall be payment in full for furnishing, handling, and storing all seed; for preparing the seed bed and sowing the seed; for furnishing, hauling, handling, storing, placing, and incorporating the fertilizer into the work; for furnishing, hauling and placing soil stabilizers; for furnishing, hauling, treating, placing, spreading, and anchoring of the

## Part II - Earthwork

mulch material unless the area is to receive erosion matting, in which case mulch is not required; for maintenance of the work and the repair of all damaged areas; and for furnishing all labor, tools, equipment, and incidentals necessary to complete the work.

Where seeding is not listed as an item on which to submit unit prices, it shall be understood and agreed that the Contractor shall seed with the appropriate terrace seed mix and be paid seventy-five cents (\$0.75) per square yard of seeding places in accordance with these Specifications.

## **ARTICLE 208 - SODDING**

---

### **208.1 Description.**

This work shall consist of preparing sod beds, furnishing and laying of live sod on the shoulders, slopes, ditches, or other locations as designated, and the construction of sod ditch checks or similar appurtenances, furnishing and applying the required fertilizer, as shown on the plans, in the contract, or as ordered and laid out by the Engineer, all in accordance with these Specifications.

### **208.2 Materials.**

#### **208.2(a) Sod.**

The sod shall consist of a dense, well-rooted growth of permanent and desirable grasses, indigenous to the general locality where it is to be used, and shall be practically free from weeds or undesirable grasses. At the time the sod is cut, the grass on the sod shall have a length of approximately two inches (if longer, the grass shall be cut to approximately this length) and the sod shall have been raked free from debris.

The sod shall be cut in uniform strips approximately one (1) square yard in area. The sod strips shall be uniform in thickness; shall have no holes in them; shall be free of weeds, insects and diseases; shall be uniformly green and not discolored due to drying or heating; and shall be moist.

The thickness of the sod shall be uniform, approximately 1/2 to 3/4 inch, depending on the nature of the sod, so that practically all of the dense root system of the grasses will be retained, but exposed, in the sod strip and so that the sod can be handled without undue tearing or breaking.

In the event the sod which is to be cut is in a dry condition so as to cause crumbling or breaking during cutting operations, at least twelve (12) hours before cutting the sod, the Contractor, at no additional cost to the City, shall apply water to the sod in sufficient quantities to provide a well moistened condition of the sod to the depth to which it is to be cut.

#### **208.2(b) Fertilizer.**

Fertilizer shall conform to the requirements set forth in Subsection 207.2(b) Fertilizers.

### **208.3 Construction Methods.**

#### **208.3(a) Preparation of the Earth Bed.**

The area to be sodded shall have been previously constructed to the required cross section and contour, and the tops and bottoms of the slopes shall be rounded to a minimum four (4) foot radius curve.

The areas to be sodded shall be free from stones, roots or other undesirable foreign material.

The soil on the area to be sodded shall be loosened and brought to a reasonably fine granular texture, to a depth of three (3) to four (4) inches, by means of equipment or hand methods adapted to the purpose.

## Part II - Earthwork

### 208.3(b) Placing the Sod.

The earth bed upon which the sod is to be placed shall be moistened to the loosened depth, if not naturally sufficiently moist, and the sod shall be placed thereon within approximately twenty-four (24) hours after the same has been cut.

Sod shall be laid so that the joints caused by abutting ends of sod strips are not continuous. Each sod strip shall be so laid as to abut snugly against the strip previously laid.

As the sod is being laid it shall be rolled or firmly but lightly tamped with suitable wooden or metal tampers, sufficiently only to “set” or press the sod into the underlying soil.

At points where water will flow over a sodded area, the upper edges of the sod strips shall be turned into the soil below the adjacent area and a layer of earth placed over this juncture, which earth shall be thoroughly compacted to conduct the surface water over the upper edge of the sod.

At the limits of sodded areas, wherever practical or feasible, at the end strips shall be placed to effect a broken line, and ends of the strips shall be turned in and treated as above described.

Frozen sod shall not be placed, nor shall any sod be placed upon frozen soil.

During periods of extreme drought, defined as category D-3 Drought Extreme by the U.S. Drought Monitor, the Contractor shall be allowed to sod after the City of Madison is no longer within this classification. The Contractor must install sod within ten (10) days of the end of the D-3 Drought Extreme Classification. During this time, the Contractor must maintain all perimeter erosion control until directed by the Engineer per Section 208.4(a) Acceptance.

### 208.3(c) Staking.

On all slopes steeper than one foot vertical to four feet horizontal the sod shall be staked or pegged with pieces of plasterers’ lath or stakes equivalent thereto, twelve (12) inches in length, spaced as required by the nature of the soil and steepness of slope, from 18 inches to 36 inches apart along the longitudinal axis of the sod strip. Stakes shall preferably be placed near the top edges of the sod strip and shall be driven approximately plumb through the sod to be almost flush with the sod.

All sod placed in ditches, flumes or other appurtenances, where a concentrated flow of water may be expected, shall be staked regardless of the slope.

### 208.3(d) Top Dressing.

After the staking has been completed the surface shall be cleared of loose sod, excess soil, or other foreign material, and the areas shall then be thoroughly moistened by sprinkling with water.

### 208.3(e) Fertilizing.

When the fertilizing of areas to be sodded is required, the fertilizer shall be spread uniformly over the areas to be sodded at the rate of 17 pounds per 1,000 square feet of area unless otherwise specified in the contract. The fertilizer shall be pulverized and free from lumps when applied. The fertilizer shall be incorporated into the areas to be sodded by light discing or harrowing.

## Part II - Earthwork

### 208.3(f) Watering.

After staking and cleanup, the sod shall be thoroughly moistened by sprinkling with water. All sodded areas shall be kept thoroughly moist by watering or sprinkling, when rainfall is not sufficient to achieve rooting of the sod to the earth bed. Water shall be applied in a manner to preclude washing to erosion.

No additional compensation will be given to Contractors for watering related to dry conditions, except as specified in Subsection 208.3 (g).

### 208.3(g) Drought Watering.

The Contractor shall receive additional compensation for watering required to keep sod in flourishing condition ONLY when the following conditions are present and have been met:

1. The U.S Drought Monitor has classified the City of Madison as “D-3 Drought-Extreme” status. Weekly updates provided by the U.S. Drought Monitor are available at: [http://droughtmonitor.unl.edu/DM\\_state.htm?WI,MW](http://droughtmonitor.unl.edu/DM_state.htm?WI,MW)
2. The sod was installed greater than ten (10) days from the date seeking additional compensation.

Once the U.S. Drought Monitor has classified the City of Madison as “D-3 Drought Extreme,” the Contractor must notify the Engineer of the dates of additional watering(s) to occur within the next (7) days, and of watering(s) that occurred seven (7) days prior to classification of “D-3 Drought Extreme.” The Contractor shall receive compensation for up to four (4) additional drought waterings performed seven (7) days prior to the classification of “D-3 Drought Extreme” and four (4) additional waterings during the seven (7) day period after the U.S. Drought Monitor has classified the City of Madison as “D-3 Drought Extreme.” The Contractor will not receive “double” payments for waterings during periods of consecutive weeks of “D-3 Drought Extreme” status.

The request for additional watering(s) will be made on a weekly basis according to the weekly reports from the U.S. Drought Monitor.

In the event that there is significant rainfall (>1”), after the U.S. Drought Monitor has classified the City of Madison as “D-3 Drought Extreme”, the Contractor must notify the Engineer of the revised dates of additional watering(s) that will occur within the next (7) days.

The Engineer shall not be held responsible for informing the Contractor that additional watering(s) are necessary because of the “D-3 Drought Extreme” status by the U.S. Monitor . Plants that perish or do not thrive in a flourishing condition because of lack of watering(s) shall be the responsibility of the Contractor per Section 208.4(a) Acceptance and Section 208.4(b) Guarantee.

## **208.4 Acceptance and Guarantee.**

### 208.4(a) Acceptance.

Upon completion of all required sodding, an inspection of the work will be made by the Engineer. All sodded areas which are dead or found not to be in a normal, healthy condition or do not conform to specifications, in the judgment of the Engineer will not be accepted. All rejected work shall be



replaced by the Contractor, including removal and repair of all work affected by the replacement, at no cost to the City.

**208.4(b) Guarantee.**

All areas that have been sodded shall be guaranteed to be in a healthy and flourishing condition for a period of 1 year from the date on the certificate of completion.

At any time within the period of the guarantee, the Contractor shall replace any sodded areas which, for any reason, have died or are in a dying condition, or which has failed to flourish in such a manner or to such a degree that its usefulness or appearance has been impaired. Replacement shall include removal and repair of all affected work. Sodded areas that have perished for any reason shall be resodded with the exact variety of sod that was originally installed.

Following the completion of the repair, a re-inspection will be made prior to final acceptance.

**208.5 Method of Measurement.**

**208.5(a) Sodding.**

Sodding will be measured by the square yard, or by the trench foot and the quantity to be measured for payment under this item shall be the actual number of square yards of area or lineal feet of trench on which sod has been placed in accordance with the contract, within the limits of such construction designated on the plans or in the contract or as ordered by the Engineer.

**208.5 (b) Drought Watering.**

Drought Watering shall be measured by unit price each for additional watering visits necessary to thoroughly soak the root zones of all areas of sod. The number of watering visits shall be defined such that one watering visit thoroughly soaks the root zones of all of the sod in the contract, once.

**208.6 Basis of Payment.**

**208.6(a) Sodding.**

Sodding measured as provided above, will be paid for at the contract unit price per square yard of Sodding, or the trench foot of Sodding, which price shall be full compensation for preparing the earth bed; for furnishing, placing, staking, top dressing, and watering the sod; and for all labor, equipment, tools and incidentals necessary to complete the work in accordance with the contract.

**208.6 (b) Drought Watering.**

Drought Watering, shall be paid for at the contract unit price, which shall be full compensation for furnishing, transporting and watering plants; and for furnishing all labor, tools, equipment and incidentals necessary to complete the work. In order to receive payment for drought watering, the Contractor must submit proof of watering for each watering. This proof must including photos of the watering with the date and time that each watering occurred.

## **ARTICLE 209 - TREES, SHRUBS, PERENNIALS AND GRASSES**

---

### **209.1 Description.**

This work shall consist of furnishing and planting plants of the species, varieties and sizes specified, complete in place at the locations designated on the plans or as directed by the Landscape Architect, City Forester, Inspector or designee herein referred to as Engineer. This work shall include furnishing all necessary materials and performing all necessary work such as excavation of plant holes, salvaging topsoil, potting, transplanting, backfilling, pruning, mulching, watering, heeling in, fertilizing, wrapping, support staking, rodent protection and anti-desiccant, disposing of surplus waste materials, necessary care and required replacements pending acceptance, and such work necessary or incidental thereto to complete the item in accordance with the plans, specifications and contract.

### **209.2 Materials.**

#### 209.2(a) General.

Unless otherwise provided for or approved by the Engineer, all materials used shall conform to requirements hereinafter set forth.

#### 209.2(b) Plant Materials.

1. General. Unless otherwise specified, all plants shall be nursery grown stock that has been transplanted or root-trimmed two or more times, according to the species and size of plants.

Applicable Specifications and Standards:

American Standard for Nursery Stock, ANSI Z60.1., current edition.

Standardized Plant Names. 1942 American Joint Committee on Horticulture Nomenclature.

Pruning Standards for Shade Trees, current edition. National Arborist Association.

American Nursery Standard For Tree Care Operations, Tree, Shrub And Other Woody Plant Maintenance- Standard Practices; ANSI A300, current edition

All plants shall be typical of their species and have well-formed tops (crowns) and root systems and shall be free from injurious insects, plant diseases or other plant pests. All plants shall be grown within the States of Wisconsin, Minnesota, Iowa, Michigan, or the parts of Illinois, Indiana, or Ohio located within Zone 5 of the "Plant Hardiness Zone Map" of the USDA, Miscellaneous Publication No. 814 - Revised 1990. Plants furnished shall conform to the American Standard for Nursery Stock and be free from the following defects:

Serious injuries to leader, branches (crown), trunk, bark or roots.

Dried out roots.

Girdling or encircling roots.

Prematurely opened buds.

Thin or poor tops (crowns) or root systems.

Evidence of molding.

Dry, loose or broken ball of earth in Balled and Burlapped (B& B) stock.

Dried out or damaged soil mass in Bare Root (BR), Balled and Burlapped (B&B) or Container Grown (CG) stock.

2. Substitution. Where evidence is submitted that a specified plant cannot be obtained, substitution may be made, only upon specific approval of the Engineer.
3. Grading Standards. Plant stock shall conform to the code of standards set forth in the current edition of the American Standard for Nursery Stock.
4. Inspection and Approval of All Plant Material. All plants shall be subject to the approval of the Engineer. Trees that will be inspected and tagged at the nursery or place of collection will be done at a time agreeable to the Contractor and Engineer. Approval of plants at the source does not alter the right of rejection at the project site. It is the right of the Engineer to reject plant material(s) at the project site. It is the responsibility of the Contractor to notify the Engineer forty-eight (48) hours prior to any plantings, as to which plants are to be planted and their location(s). Contractor shall furnish to the Engineer an invoice or order form from each nursery indicating the sources from which he proposes to obtain plant materials for the work at this time confirming what will be delivered. This list shall include species name, cultivar, root condition (container, bare root or B&B) and size. All plants shall conform to the measurements specified in the plant list. Measurements specified shall be the minimum size acceptable for each variety. Plants that meet the requirements specified in the itemized plant list, but that do not possess a normal balance between height and spread, will not be accepted. Plants shall not be pruned prior to delivery. Tree branching shall be evenly spaced around the trunk without excessive gaps between the whorls. Trees with multiple leaders, unless specified, will be rejected. Central leaders shall be left intact.

### **209.3 Digging, Handling and Packing Plant Stock.**

#### **209.3(a) General.**

All plant stock shall be freshly dug and handled with care and skill to prevent injuries to the leaders, branches, trunk and roots, and shall be packed in accordance with the requirements of the current edition of the State of Wisconsin DOT Standard Specifications for Road and Bridge Construction.

#### **209.3(b) Digging and Handling of Plant Material.**

Care shall be taken to prevent any damage to plant material during transit and handling. The Engineer shall check trees for any shipping or handling damages. Trees with excessive damage as determined by the Engineer shall be rejected.

Plant stock to be furnished Balled and Burlapped (B&B) shall be moved with a compact dug ball of earth so firmly wrapped in burlap that upon delivery the soil in the ball is still firm and compact about the root system. Each ball shall be of sufficient size to encompass all the fibrous roots necessary to insure successful recovery and development of the plant. Root balls shall not be allowed to dry out between digging and planting. The minimum sizes of balls, ball depth and diameters, and increased ball sizes for collected stock shall be in accordance with Recommended Balling and Burlapping Specifications as set forth in the current edition of the American Standard for Nursery Stock sponsored by the American Association of Nurserymen, Inc. No plant will be accepted when the burlap, twine, wire or ropes required to secure the root ball have been removed. Ropes, strings, wire baskets, burlap, and other wrappings shall be removed from the entire plant before installation is complete. The balance of the wrappings may be left intact around the bottom of the ball. All balled and burlapped plants that cannot be planted immediately on delivery shall be set on the ground and

the balls well covered with soil or other acceptable mulch material and shall be kept moist until planted.

Plant stock to be furnished Bare Root (BR) shall be dug with bare roots protected against drying out by use of moist sphagnum moss or other suitable material and covered with canvas or other suitable material in an approved manner.

Plants marked "CG" shall be container grown with a well-established root system. Container grown plants are to be well-established within the container, with a root system sufficiently developed to retain its shape and hold together when removed from the container. Roots should be noticeable when removed from the container, but not protruding outside the container. Soil within the container should be held together by the roots, in form and whole. Plants shall not be bound nor have kinked, circling, or bent roots.

All plants shall be handled so that the roots are adequately protected at all times. During shipment, all plants shall be properly protected by a tarpaulin or other suitable covering. No plant shall be so bound with rope or wire at any time as to damage the bark, break branches, or destroy its natural shape. All balled and burlapped and container grown plants which cannot be planted immediately on delivery shall be set on the ground and well-protected with soil or other acceptable material. Bare rooted plants shall be planted or heeled-in trenches immediately upon delivery. If heeled-in, all bundles of plants shall be opened and the plants separated before the roots are covered and care shall be taken to prevent air pockets among the roots. Until planted, all material shall be maintained.

Plants shall be marked for identification and for checking as designated on the plant list. Each bundle of plants and all separate plants shall have legible, waterproof labels securely attached thereto before delivery to the site.

Prior to any excavation, the Contractor shall notify Diggers Hotline at 1-800-242-8511 to determine the location of all electric, gas, water, sewer, oil and other utility lines, including tanks or other sub-surface encumbrances, and precautions shall be taken by the Contractor not to disturb or damage any utility lines. In the event of a conflict of a utility with the planting, the Contractor shall promptly request, in writing, from the Engineer a revised location for plant material.

#### **209.4 Construction Methods.**

##### **209.4(a) General.**

Unless otherwise specified on plans, the spring planting season for all plants is as follows: BR plants shall be planted from the time the frost is out of the ground to bud break; B&B plants shall be planted from the time frost is out of the ground to June 1st. Deciduous, grass or perennials container grown plants may be planted from the time frost is out of the ground through October 15th. Unless otherwise specified on plan, the normal fall planting season for all deciduous trees shall begin no earlier than October 1st. Fall evergreen tree and shrub planting shall be done between August 15th and September 15th. Unless otherwise approved, planting shall not be done where the ground is frozen or when soil is in an unsatisfactory condition for planting.

##### **209.4(b) Delivery and Temporary Storage.**

At least forty-eight (48) hours prior to each delivery of plant material to the potting, storing or project site, the Contractor shall notify the Engineer of delivery.

Insofar as practicable, plant stock shall be planted on the day of delivery at the project site. In the event this is not possible, the plant stock shall be temporarily stored by “heeling-in” or by placing in a well-ventilated, cool, moist storage place and shall be adequately protected against drying by the use of moist sphagnum moss, straw or other suitable covering around the roots of BR stock and balls of B&B stock.

Bare root plants, when “heeled-in”, shall be placed in a spade depth trench, have their roots fully covered with damp topsoil and be protected from the sun and wind. When “heeled-in”, all plants shall be properly cared for by the Contractor. Failure to protect stock shall be cause for rejection of plant material.

Upon delivery, the Contractor shall furnish a delivery receipt or invoice from the nursery that includes the species, cultivar, quantity and size of plants delivered.

#### 209.4(c) Layout of Planting.

The Engineer will designate the location of all trees and shrubs marker stakes or paint marks on the ground. The Engineer shall receive notice 48 hours minimum will be required of Contractor for all plant site selection. The plant location and type will be staked as permanently as possible. The Contractor shall be responsible for maintaining these locations until planting occurs.

#### 209.4(d) Excavation of Plant Holes.

The plant holes shall be centered at the location stake, unless otherwise permitted by the Engineer. Plant holes to be 3 times the ball/pot diameter.

The plant hole, except for Machine Transport (MT) stock, shall be excavated to the minimum dimensions shown on the plans or established by the Engineer, provided, however, that the plant hole shall be large enough to permit placing at least six (6) inches of backfill material around the root system of BR stock and the pots, balls or containers of B&B and CG stock. When a minimum size hole is excavated, the hole shall be excavated cylindrical in shape with vertical sides and a flat or saucer-shaped bottom.

Unless soil conditions make it impractical, planting holes for Machine Transport plants shall be done by the tree moving machine and shall be approximately the same size and shape as the soil mass containing the root system of the machine moved plant. The plant shall be dug set to match existing grade, backfilled with screened topsoil and watered in to eliminate all voids.

The topsoil suitable for backfilling shall be kept separate from the excavated subsoil and sod.

When planting on a slope the minimum depth of the plant hole shall be measured from the downward side of the slope at the hole.

#### 209.4(e) Pruning.

Any plants requiring pruning shall be pruned at the planting site as specified by the Engineer. Prior to planting, damaged or broken parts of the fleshy roots shall be cut off smoothly to a point where they are clean and clear of rot, while preserving as much of the root system as possible. When/where specified or directed by the Engineer, for all BR, B&B, or CG plant stock, pruning shall consist of

removing only dead, damaged, or broken branching. Pruning shall be done so that the plant retains its natural form and leaving the central leader intact.

Except when heading back, all pruning cuts shall be made at the branch bark ridge and branch collar leaving both branch features intact without leaving stubs or damaging adjacent trunk or branch tissue. When heading back or reducing a branch back to another lateral branch, all pruning cuts shall be made by bisecting the angle between the branch bark ridge and an imaginary line which is perpendicular to the branch being removed. The branch bark ridge must be left intact without leaving a stub and without damaging adjacent branch tissue. Evergreen plants shall not be pruned except to remove dead, damaged, or broken branches. All pruning cuts shall comply with the ANSI A300 current edition. See Part VIII, Standard Plates 2.04 and 2.05 for Proper Pruning Cuts

209.4(f) Anti-Desiccant.

Anti-desiccant, when specified, shall be applied to evergreen plants prior to or at the time of planting and to BR plants prior to shipment from the storage place. It shall be applied to plants to be transplanted prior to transplanting. The rate and method of application of the emulsion shall be according to the manufacturer's recommendations.

209.4(g) Planting.

All planting of BR, B&B, and CG stock. When a minimum size hole is excavated, the hole shall be excavated cylindrical in shape with vertical sides and a flat or saucer shaped bottom. Scarification of the excavated hole will be required to prevent glazing (as per planting detail).

Bare root plants shall have their roots spread into a natural position, free of bunching, kinking, or circling. All broken or damaged roots shall be cut back to the closest point where they are clean and free of rot. No other root pruning shall be done

For plants in plastic, biodegradable or metal containers, the container shall be removed before planting. If roots are crowded or coiled on the bottom, sides, or surface of the root ball, they shall be gently separated from the edges or surface. Ropes, strings, wire baskets, burlap, and other wrappings shall be removed from the top one-half (1/2) of the ball after the plant has been set. The balance of the wrappings may be left intact around the bottom of the ball. For all plants moved with a tree spade, all holes and cavities between the ball and the surrounding soil shall be filled. Glazed planting hole surface shall be sufficiently roughened prior to backfilling. The ball shall be thoroughly watered at planting time.

Plants shall be set with the root flare at the finished grade (root flare shall be determined 1" above the upper-most woody support root). Plants must be centered in the hole and set plumb. Plants shall be set so that they will be at the same depth at the end of the guarantee period.

Planting holes shall be backfilled with excavated soil. Salvaged topsoil shall be placed in layers around the roots or ball. Frozen or muddy soil will not be acceptable suitable backfill material. Backfilling shall be carefully done in a manner that avoid injury to the roots or ball or disturbing the position of the plant. When holes are approximately two-thirds full, they shall be thoroughly watered to eliminate air pockets. After this initial watering, excavated soil shall be installed to the top of the hole and thoroughly watered. Puddled soil conditions shall be avoided.

Planting areas shall be finish-graded to conform to drawings after full settlement has occurred.

## Part II - Earthwork

All plants shall be mulched with either shredded hardwood bark or wood chips over the root system from two (2) inches to a maximum depth of 4 inches immediately after planting. Mulching material shall be pulled back one (1) to two (2) inches away from the trunk of the tree. Mulch shall not be in contact with the trunks.

All twine rope, transit guards or wrappings, and plant labels secured around the trunk or branches shall be removed after the planting is completed.

### 209.4(h) Planting Large Caliper Tree Spade Stock.

The grading of the tree pit shall form a saucer at least four (4) inches in depth. Care shall be taken when lowering and raising the tree ball into the hole by use of a sling and an appropriate device as agreed upon by the Engineer. When centering the tree in the hole, the tree trunk is not to be used as the lever device to move the ball, rather some other lever method must be used at the approval of the Engineer. The center of the tree shall be centered within the tree grate to + 1" from the true center of the tree grate to the center of the tree trunk at the finished sidewalk grade.

### 209.4(i) Water Tubes.

Watering tubes shall not be routinely installed in any tree planting process. When directed by Engineer during the planting process, watering tubes shall be installed by contractor.

### 209.4(j) Fertilizer.

Unless otherwise specified, the Contractor shall furnish and place around trees and shrubs one ounce (1 oz.) root contact packets, place after plant hole has been two-thirds (2/3) backfilled. Number of packets to place shall be as follows: 1 packet - bare root shrubs, 2 packets - bare root trees and balled and burlapped shrubs, 4 packets - B&B trees up to three (3) inch caliper, 6 packets - B&B trees three (3) inch caliper and larger. Trees shall not be routinely fertilized when planted.

### 209.4(k) Mulching.

After planting operations have been completed, planted areas shall be entirely covered with a layer of mulch that is two (2) to four (4) inches deep at the rate of nine (9) cubic yards per 1,000 square feet. The mulch shall be applied one (1) to two (2) inches away from the trunk of the tree. Mulch shall not be in contact with the trunk and shall be maintained as such during the guarantee period. Mulch shall not come in contact with the trunk. When/where indicated on plan or by Engineer, a 6 oz. non-woven permeable landscape fabric/soil separator shall be placed between mulch and soil.

For trees in tree grates and when/where specified, #2 washed stone mulch shall be installed in the watering tubes and grate opening. Mulch shall be three (3) to six (6) inches deep, flush with the underside of the tree grate after settlement and compaction.

Landscape fabric, when/where specified, shall be placed within the layer of washed stone mulch at a depth of 2" below the finish grade of mulch prior to installing the tree grate. The landscape fabric should be cut and installed to the size and shape of the tree grate, including the tree trunk opening. The tree trunk opening of this landscape fabric shall be the same size as the grate opening to facilitate watering and root collar development.

## Part II - Earthwork

Following installation of the grate, additional stone mulch shall be installed around tree trunk until even with the top of the tree grate.

### 209.4(l) Wrapping.

Before trees are wrapped, the Engineer shall inspect the plant stock.

When specified to be wrapped, the trunks of trees shall be wrapped with wrapping material overlapping one and one-half inches, starting from the ground line to the lowest main branches. The wrapping shall be secured in at least three places with masking tape, including the top, middle and bottom. The wrapping shall be done as soon as practical after planting as specified by the Engineer.

### 209.4(m) Protection.

When required, a protective material shall be applied to plants. This shall consist of one of the materials permitted under Subsection 209.5(e) applied or installed according to Special Provisions and Details.

### 209.4(n) Support Staking.

When specified, trees shall be supported with at least two (2) stakes driven into the ground near the base of the tree to a depth of two (2) to three (3) feet or until sufficiently solid to support the tree, and shall extend upward to about six (6) inches below the lowest main branches. The tree shall be fastened to the stake by means of soft strapping at least one (1) inch wide, or banding in such a manner as to avoid injury to the tree. In no case shall the strap or banding extend completely around the trunk. Material should be attached loosely enough to allow a small amount of play at the trunk. Stakes are to be placed within the mulched area. Plant stakes shall be removed by the Contractor within a one year period subject to the approval of the Engineer.

### 209.4(o) Disposal of Excess and Waste Material.

All excess excavation, waste materials, or other debris shall be removed and disposed of by the Contractor.

## **209.5 Backfill Material.**

### 209.5(a) Topsoil.

All plant holes shall be backfilled with excavated soil. Topsoil shall be salvaged from the planting site whenever suitable for reuse as determined by the Engineer. When holes are approximately two-thirds full, they shall be thoroughly watered to eliminate air pockets. Remaining/additional soil to be installed to the top of the hole and watered. Puddled soil conditions shall be avoided. Additional topsoil shall be of a reasonably fine granulated texture suitable for the purpose and acceptable to the Engineer. Additional topsoil will be supplied by the Contractor as required at no additional cost to the City. Topsoil used as backfill material for plant material to be amended with an acrylamide copolymer soil amendment when/where specified as approved by the Engineer.

The sod from the plant hole excavation may not be used for backfill.



209.5(b) Fertilizer.

Fertilizers when/where specified, shall be of the slow release type contained in polyethylene, perforated bags with micropore holes. Each bag shall contain a minimum of one(1) ounce of soluble fertilizer with an analysis of 16-8-16 per unit or approved equal. The minimum guaranteed analysis shall be total nitrogen 16%, 9% annomical nitrogen, 7% nitrate nitrogen. Available phosphoric acid P2 O5 (from ammonium phosphate) 8%, soluble potash (from potassium chloride) 16%.

209.5(c) Mulch.

Mulch shall consist of shredded hardwood bark or wood chips or an equivalent material as approved by the Engineer and shall be free of objectionable foreign material. Contractor shall furnish a sample of the mulch that will be used. Where shrubs or perennials/annuals or bulbs are installed in planting bed, shredded or ground hardwood bark shall be used or product approved by the Engineer prior to installation. When/where indicated on plan or by Engineer, a 6 oz. non-woven permeable landscape fabric/soil separator shall be placed between mulch and soil.

209.5(d) Wrapping.

Before trees are wrapped, the Engineer shall inspect the plant stock.

Wrapping, when/where specified, shall consist of a two-ply waterproofed crepe tree wrapping paper, laminated with a layer of pliable asphalt material. The wrap shall tightly cover the entire surface of the trunk, overlapped one and one-half inches in spiral fashion, starting at the base of the tree and extending to the height of the first branches. The wrapping shall be secured in at least three places with masking tape. The contractor will be responsible for removing and disposing of the tree wrap after a one year period.

209.5(e) Protection.

Protection, when/where specified, shall consist of galvanized hardware cloth, extruded aluminum mesh or a durable pre-formed plastic material. The hardware cloth or aluminum mesh, if used, shall have at least three meshes per linear inch and shall be used in conjunction with a steel rod having a minimum size of 3/8 x 48 inches. The plastic material shall be a durable, resilient, preformed plastic spiral acceptable to the Engineer. Such material shall have a natural, earth-tone color. . The contractor will be responsible for removing and disposing of the protection at the end of the guarantee period unless otherwise specified by the Engineer.

209.5(f) Support Staking Materials.

When/where specified, these materials shall consist of such wood or steel stakes, soft straps or banding material as needed to perform the work. Support stakes shall be of solid durable wood approximately two by two inches and of the required length.

In no case shall the strap or banding material extend completely around the tree trunk. Material should be attached loosely enough to allow a small amount of play in the trunk.

The Contractor will be responsible for removing all stakes and straps after a one year period, subject to approval of the Engineer.

## Part II - Earthwork

### 209.5(g) Anti-Desiccant.

Anti-desiccant, when/where specified, shall be an approved emulsion which will provide a film over plant surfaces permeable enough to permit transpiration.

### 209.5(h) Watering Tubes.

Watering tubes shall not be routinely installed as part of any tree planting process. Watering tubes, when specified, shall be six (6) inch diameter perforated Poly (Vinyl Chloride) (PVC) pipe, twenty-four (24) to thirty (30) inches long and shall be filled with a 1-1/2 - 2 inch river-washed stone.

### 209.5(i) Watering Equipment.

The Contractor shall furnish and have available sufficient watering equipment, including tanks, pumps, hoses, root feeders and incidentals to fully perform all of the watering. Water will be furnished to the Contractor by the City from existing facilities if requested by the Contractor in accordance with Section 107.11 of these Specifications. When the Contractor chooses to use City of Madison water for any part of the project, then the Contractor must proceed as follows:

1. Request Water Utility to install valve on convenient hydrant.
2. Agree to pay Water Utility charges for installation, use and removal of the valve.
3. Notify Water Utility immediately when use of valve is no longer necessary.

The Contractor shall not make connections to Water Utility facilities without permission from the Water Utility.

### 209.5(j) Drought Watering.

The Contractor shall receive additional compensation for watering required to keep plants in a healthy growing condition ONLY when the following conditions are present and have been met:

1. The U.S Drought Monitor has classified the City of Madison as “D-3 Drought-Extreme” status. Weekly updates provided by the U.S. Drought Monitor are available at: [http://droughtmonitor.unl.edu/DM\\_state.htm?WI,MW](http://droughtmonitor.unl.edu/DM_state.htm?WI,MW).
2. The plantings were installed greater than ten (10) days from the date seeking additional compensation.

Once the U.S. Drought Monitor has classified the City of Madison as “D-3 Drought Extreme,” the Contractor must notify the Engineer of the dates of additional watering(s) to occur within the next (7) days, and of watering(s) that occurred seven (7) days prior to classification of “D-3 Drought Extreme.” The Contractor shall receive compensation for up to four (4) additional drought waterings performed seven (7) days prior to the classification of “D-3 Drought Extreme” and four (4) additional waterings during the seven (7) day period after the U.S. Drought Monitor has classified the City of Madison as “D-3 Drought Extreme.” The Contractor will not receive “double” payments for waterings during periods of consecutive weeks of “D-3 Drought Extreme” status.

The request for additional waterings will be made on a weekly basis according to the weekly reports of the U.S. Drought Monitor.

In the event that there is significant rainfall (>1”), after the U.S. Drought Monitor has classified the City of Madison as “D-3 Drought Extreme,” the Contractor must notify the Engineer of the revised dates of additional watering that will occur within the next (7) days.

The Engineer shall not be held responsible for informing the Contractor that additional watering(s) are necessary because of the “D-3 Drought Extreme” status by the U.S. Monitor. Plants that perish or do not thrive in a flourishing condition because of lack of watering(s) shall be the responsibility of the Contractor per Section 209.6(a) Acceptance, Section 209.6(b) Care and Section 209.6(c) Guarantee.

## **209.6 Acceptance and Guarantee.**

### **209.6(a) Acceptance.**

Upon completion of all required planting, an inspection of the work will be made by the Engineer. All plants which are dead or found not to be in a normal, healthy condition or do not conform to specifications, in the judgment of the Engineer will not be accepted. All rejected work shall be replaced by the Contractor, including removal and repair of all work affected by the replacement, at no cost to the City.

### **209.6(b) Care.**

The Contractor shall properly care for all plants while the payment and performance bond remains in effect. The performance and payment bond shall remain in effect for one year from the date on the certificate of completion.

Proper care of plants shall consist of doing such watering, weeding, cultivating, pruning, spraying, securing of braces and guys, wrapping, re-mulching and such other work as may be necessary to keep the plants in a neat appearance and in a healthy growing condition. No additional compensation will be given to Contractors for watering related to dry conditions, except as specified in Subsection 209.6(c).

It shall be the Contractors responsibility to thoroughly water and care for plants, especially during the ten (10) day period after initial planting. No additional compensation will be given for watering during the first ten (10) days of initial planting, regardless of drought status.

Street trees shall be pruned by the City Forester. In addition to the waterings required in Subsection 209.4(g), entitled Planting, additional waterings may be ordered by the Engineer at any time, for the duration of the guarantee period. Should conditions require such waterings, Contractor shall water within three (3) days of notification. The volume of each watering and intervals between waterings shall depend upon weather conditions and soil moisture. Contractor shall monitor weather and soil condition of each planting.

Care must be taken when watering not to wash away mulch and topsoil. Mulch and topsoil displaced by the Contractor must be replaced immediately per section 209.4(k).

### **209.6(c) Guarantee.**

Plants shall be guaranteed for two years from the date of on the certificate of completion.

## Part II - Earthwork

At any time within the period of the guarantee, the Contractor shall replace any plant which, for any reason, has died or is in a dying condition, or which has failed to flourish in such a manner or to such a degree that its usefulness or appearance has been impaired. Replacement shall include removal and repair of all affected work. The decision of the City as to the necessity of replacing any plants shall be conclusive and binding on the Contractor. No more than two (2) replacements per plant shall be required after acceptance.

Following the completion of the replacements, a re-inspection will be made prior to final acceptance.

All replacement plantings are to be selected and tagged by the Engineer prior to being brought to the job site. It is the responsibility of the Contractor to notify the Engineer forty-eight (48) hours prior to any replacement plantings as to what they are to be planting and in what location.

Prior to the termination of the guarantee period, the Contractor shall request a final inspection by the City. All plants found unacceptable for reasons herein before stated shall be replaced at the first planting season and thereafter the responsibility for such plants or material shall lie with the City, no additional guarantee period will be required for these plantings.

### 209.6(d) Contract Time.

Contract time will not be charged when making replacements, unless other contract operations are in progress during said period.

## **209.7 Method of Measurement.**

### 209.7(a) Plants.

This work will be measured by the number of plants of each species, variety and size complete in place and accepted in accordance with the terms of the contract.

### 209.7(b) Drought Watering.

Drought Watering shall be measured by unit price for additional watering visits necessary to thoroughly soak the root zones of all plants in the contract. The number of watering visits shall be defined such that one watering visit thoroughly waters all of the plants in the contract, once.

## **209.8 Basis of Payment.**

### 209.8(a) Plants.

The number of plants, furnished and planted, measured as provided above, will be paid for at the contract unit price each for Trees (Species and Size), Shrubs (Species and Size), or Vines (Species and Size) and Perennials/Grasses (Species and Size), as the case may be, which price shall be payment in full for furnishing, transporting, handling, potting, storing, pruning, placing and replacing plant materials; for all excavation of plant holes, salvaging of topsoil, mixing and backfilling; for furnishing and applying all required fertilizer, mulch, water, wrapping, guys and braces, rodent protection, herbicides and anti-desiccant spray; for removing guys and braces; for disposal of all excess and waste materials; for care; and for furnishing all labor, tools, equipment and incidentals necessary to complete the work, except topsoil for use in planting, which will be paid for on a cubic yard basis.

209.7(b) Drought Watering

Drought Watering, shall be paid for at the contract unit price each, which shall be full compensation for furnishing, transporting and watering plants; and for furnishing all labor, tools, equipment and incidentals necessary to complete the work. In order to receive payment for drought watering, the Contractor must submit proof of watering for each watering. This proof must including photos of the watering with the date and time that each watering occurred.

## **ARTICLE 210 - EROSION CONTROL**

---

### **210.1 Description.**

Soil erosion and uncontrolled runoff from construction and land disturbing activities can have adverse impacts upon regional water resources and the health, safety, property and general welfare of the community. The Contractor shall conduct and schedule operations so as to avoid or minimize siltation of streams, lakes, reservoirs and other areas. The Contractor shall also take all necessary precautions to prevent pollution of streams, lakes, reservoirs and other areas with fuels, oils, bitumen, calcium chloride, or other harmful materials. Requirements for the treatment of runoff associated with dewatering Type I or Type II is addressed in section 502 of these Standard Specifications.

The Contractor shall have adequate erosion control measures available on site for erosion control as per the plans, special provisions and Standard Detail Drawings or as determined necessary by the Construction Engineer. The type and amount of erosion control materials required will be determined by the type and amount of open excavation and/or the erosion control plan. The Contractor shall schedule the work so that the amount of open excavation and the stockpiling of construction materials on the job site are minimized.

Excavated materials and imported backfill materials stockpiled at the project site shall be stored and protected in such a manner that will not result in transport of said materials by stormwater runoff into adjacent streets or drainage facilities. Unprotected excavated materials and imported backfill materials stored temporarily on street pavements to facilitate construction shall be removed and/or properly stored/protected by the end of the work period, which shall not extend past the end of the work day.

Backfilled trenches and other areas shall be left to the level of the adjacent area or slightly below until restored to reduce the potential for erosion. All excess excavated materials and imported backfill materials shall be promptly removed from the site and disposed of following completion of construction and/or restoration activities.

Tracking of foreign materials (mud, silt, etc.) on street and/or other paved surfaces shall be controlled during the working day as necessary and/or as directed by the Construction Engineer, but no later than the end of the working day, by one or more of the following methods:

1. Hand shoveling material off street or pavement surfaces.
2. Machine removal (such as with endloader or grader), provided that the results are equal to that of hand shoveling.
3. Mechanical sweeping of material off paved surfaces and adjacent streets.

Diversion berms or sediment filtration berms shall be constructed and maintained as determined necessary by the erosion control plan and/or the Construction Engineer in order to route off-site stormwater runoff around disturbed work areas.

Replacement/repair of pre-existing erosion control measures which are disturbed in the course of the work shall be completed promptly following completion of the work on the project causing such disturbance.

## Part II - Earthwork

The Contractor shall be responsible for final stabilization and restoration of any disturbed street terrace areas within 10 calendar days after pouring of the adjacent curb and gutter and/or sidewalk, unless alternate phasing is approved by the Construction Engineer. The restoration time limit does not start when all of the adjacent concrete work is completed for the project, but rather starts as each section of curb and gutter and/or sidewalk is completed. This shall be interpreted by the Contractor to require multiple trips to the job site by the landscaping crew and/or subcontractor as required to meet these terrace restoration time limits.

### 210.1(a) Erosion Control Implementation Plan.

Whenever a project requires erosion control permitting for land disturbance of 20,000 square feet or more **or as required by the project plans and specifications** the Contractor shall prepare and submit an Erosion Control Implementation Plan to the Construction Engineer. This plan shall be submitted at or before the preconstruction meeting for review and must be approved by the City Erosion Control Engineer prior to any land disturbance activities or beginning installation of erosion control measures. The Erosion Control Implementation Plan bid item shall include all work required to create, update, submit, obtain approval for, and initially field inspect an erosion control plan specific to the Contractor's proposed staging and planned methods of construction for the project. The individual erosion control measures necessary for construction of the plan shall be paid under the appropriate bid items.

The Contractor shall understand that a comprehensive phased plan showing the Contractor's approach to minimize the disturbed area at any given time is required to obtain approval of the Erosion Control Implementation Plan. The phasing shall consist of a minimum of two (2) phases for construction with no maximum number of phases. The Contractor shall not simply resubmit the erosion control plan provided with the plan set as what they intend to implement. Upon approval of the implementation plan it shall be provided to the WDNR, when applicable.

**The Contractor shall supply a dewatering plan as part of the Erosion Control Implementation Plan. At a minimum the dewatering plan shall include the Contractor's methods, practices, and or devices to perform TYPE I or TYPE II Dewatering per Section 502.1(c) Dewatering in the City of Madison Standard Specifications for Public Works Construction and Wisconsin Department of Natural Resources (WDNR) SOC Technical Standard 1061 Dewatering. If TYPE II Dewatering is expected to be used at a rate in excess of 70 g.p.m. the dewatering plan shall also include a copy of any applicable WDNR permits.**

Prior to beginning any land disturbing construction activities the Contractor shall install all required erosion control practices for the first phase of the approved Erosion Control Implementation Plan and an initial implementation inspection (performed by City Engineering staff) must approve the installation. Prior to proceeding with work on each subsequent construction phase the appropriate erosion control measures from the Erosion Control Implementation Plan shall be installed and the installation approved by the Construction Engineer.

### 210.1(b) Erosion Control Inspection.

The Contractor shall complete an inspection of the erosion control practices on permitted projects with 20,000 square feet or more of land disturbance **or an Erosion Control Implementation Plan** within 24 hours of the end any **Friday or Saturday** rain day exceeding 1/2" in total depth or as directed by the Construction Engineer. A rain day is defined as each 24-hour calendar day and shall be measured using a gauging station that shall be provided at the preconstruction meeting by City

staff. The data from the rain gauging station shall be available on the internet to allow remote checking of the rain depth totals for each rain day. All weekly inspections and rain event inspections required during the work week (Monday-Friday) shall be completed by the City of Madison construction inspector.

Upon completion of the erosion control inspection the Contractor shall provide an email report indicating the status (Good, Failed, Maintenance Needed, etc) of each individual erosion control practice being used to the Construction Engineer or to the designated representative as identified at the preconstruction meeting. A digital photo or video of each individual erosion control practice requiring maintenance or repair shall be included in the inspection report. The inspection report shall be submitted and any needed maintenance or repairs completed by the Contractor within the same 24-hour period after the end of the rain day. The completed maintenance and repairs shall then be documented and a follow-up inspection report submitted within 24 hours following completion of the repairs. The follow-up inspection report shall include a summary of maintenance items by erosion control BMP maintenance pay item and digital photos or videos of each erosion control practice following maintenance or repair.

Erosion control inspections and reports that are completed more than 24 hours after the end of a rain day as defined above but not more than 48 hours will be paid at half the unit price. Any required erosion control inspection or inspection report that is completed more than 48 hours after the end of rain day or report due date will be assessed a penalty equal to one (1) day of liquidated damages per the table in Section 109.9 Liquidated Damages of these Standard Specifications.

The Contractor shall continue erosion control inspections on a project until a minimum of 70% vegetation establishment has been obtained or other permanent surface restoration has occurred as determined by the Construction Engineer (matting, pavement, sod, etc.).

**210.1(c) Construction Entrance, Street Construction Entrance Berm.**

When required, either by the erosion control plan or the Construction Engineer, a Construction Entrance and/or Street Construction Entrance Berm shall be installed to provide mud tracking control at each construction access point to the project. The Construction Entrance and Street Construction Entrance Berm bid items shall include the installation of entrances per Standard Detail Drawings 1.07 and 1.08 respectively. Maintenance of the entrance, removal, restoration and/or repair of any disturbed or damaged area within the immediate limits of the entrance (including the curb and gutter, sidewalk and pavement) shall also be considered incidental to the entrance bid items.

**210.1(d) Street Sweeping.**

When required, either by the erosion control plan or the Construction Engineer, the Contractor shall perform street sweeping on all streets or paved surfaces affected by construction equipment, hauling or related construction activities that result in mud tracking or siltation. Street sweeping shall be completed as directed by the Construction Engineer and shall remove all loose material to the satisfaction of the Construction Engineer. Depending on site conditions, construction activities, and hauling methods utilized by the Contractor street sweeping may be required multiple times throughout the day with an absolute minimum that all streets are clean at the end of the work day.



210.1(e) Clear Stone Berm (Ditch Check), Street Construction Stone Berm.

When required, either by the erosion control plan or the Construction Engineer, a Clear Stone Berm (Ditch Check) and/or Street Construction Stone Berm shall be installed to reduce runoff velocities in areas of concentrated stormwater runoff flow. Clear Stone Berm (Ditch Check) and Street Construction Stone Berm shall be installed per Standard Detail Drawings 1.05 and 1.10 respectively. Maintenance and removal of stone berms shall be considered incidental to their respective bid items.

210.1(f) Silt Fence, Silt Sock, Erosion Bales.

When required, either by the erosion control plan or by the Construction Engineer, perimeter controls consisting of silt fence, silt sock or erosion bales shall be installed to protect down slope areas from silt laden runoff generated from disturbed work areas. Perimeter controls shall be installed per their respective Standard Detail Drawings (1.01 for Silt Fence, 1.09 for Silt Sock, and 1.03 for Erosion Bales).

210.1(g) Inlet Protection.

Inlet protection shall be used at both existing and new inlets that receive runoff from disturbed land areas. The type of inlet protection required at each structure shall be specified in the erosion control plan or determined by the Construction Engineer. Upon completion of the project and after the Construction Engineer has determined the site to be sufficiently stabilized all inlet protection shall be removed by the Contractor. Removal shall be completed prior to final acceptance of the project.

Inlet Protection, Type C and Inlet Protection, Type C Modified shall be installed per Standard Detail Drawing 1.04 or as an approved equal as determined by the Construction Engineer or Erosion Control Engineer.

Inlet Protection, Type D and Inlet Protection, Type D Modified shall be installed per Standard Detail Drawing 1.06 or as an approved equal as determined by the Construction Engineer or Erosion Control Engineer.

Inlet Protection, Type D Hybrid shall be installed per Standard Detail Drawing 1.11 or as an approved equal as determined by the Construction Engineer or Erosion Control Engineer.

210.1(h) Clean Sump.

Clean Sump is the vector removal of sediment that has accumulated in the sumps of Catchbasins constructed as part of the project. This work shall include but not be limited to removal of any sediments collected in the sump or on the erosion fabric, and disposal or reuse of the sediments at a location provided by the Contractor (this location shall be stable and have sufficient erosion control). The Construction Engineer shall have final determination if sump cleaning is required. If cleaning is required it shall be completed prior to final acceptance of the project.

210.1(i) Polymer Stabilization.

Polymer Stabilization shall include placing a polyacrylamide soil stabilizer on bare ground to stabilize the area. This item shall be used as directed by the Construction Engineer to stabilize areas that are prone to erosion during construction. Note that this item is not intended to cover polymer to be included with all seeding (which shall be compensated as part of the seeding bid items) but shall cover supplemental polymer stabilization of erosion-prone areas during construction. Polymer shall

be applied in conformance with WDNR standard 1050 for Land Application of Anionic Polyacrylamide.

**210.1(j) Erosion Matting.**

When required, either by the erosion control plan or by the Construction Engineer, erosion matting shall be installed to reduce soil erosion caused by concentrated runoff or rainfall impact. The erosion mat supplied shall be one of the products listed on the PAL under the specified category, and shall conform to Wisconsin Department of Transportation requirements for the specified category.

**210.1(k) Terrace Restoration.**

Terrace Restoration shall include the provision, placement and finish grading of a minimum thickness of 4" of topsoil and the restoration with Shade or Sun Terrace Mix as directed in the field. The seeding work shall conform to the specifications in Article 207 - Seeding.

In greenways and detention basin areas, a minimum thickness of six inches (6") of topsoil shall be required.

**210.2 Materials.**

**210.2(a) Silt Sock.**

Silt sock provided shall be 8 or 12 inches in diameter as determined by the approved erosion control plan or as directed by the Construction Engineer. The silt sock shall be manufactured from a Multi-Filament Polypropylene (MFPP). The MFPP shall have a maximum mesh opening of 1/8 in, a minimum tensile strength of 202 psi, and a 100% original strength from ultraviolet exposure at 1000 hours (ASTM G-155). The silt sock shall be filled with either a compost filler material or a wood chip filler material with no pieces larger than 2 inches. Under no circumstances shall the compost filler material contain any animal waste or byproducts. Wooden posts for staking silt sock shall be 2 in X 2 in X 36 in and staking shall be at 10-foot intervals.

**210.2(b) Polyacrylamide Soil Stabilizers.**

Polyacrylamide Soil Stabilizers shall conform to the WDOT's Product Acceptability List (PAL) for Soil Stabilizers, Type B.

**210.2(c) Erosion Matting.**

Erosion Matting provided shall be of the Class and Type specified. The Class and Type requirements listed below match those of the Wisconsin Department of Transportation nomenclature. Products currently listed in the Wisconsin Department of Transportation's Product Acceptability List (PAL) for the Class and Type specified shall be considered to meet the City of Madison's Specifications. However, only products listed in the PAL that are constructed with 100 percent biodegradable material will be permitted on City of Madison projects, with the exception of Class III materials. For clarification purposes Class I Type A, Class I Type B, Class II Type A, and Class II Type C mats shall be designated ORGANIC to ensure provision of a product with 100 percent biodegradable matting, netting, and stitching. Photodegradable is NOT equivalent to biodegradable. Products listed in the PAL as Class I Urban Type A and Class I Urban Type B are all 100 percent biodegradable, and therefore do not need to be designated ORGANIC. Class III ECRM is not required to be constructed of biodegradable material.

**CLASS I** All Class I erosion mats shall be a light-duty, organic erosion control revegetation mat (ECRM). Class I mat shall have an expected working duration of a minimum of six (6) months. All Class I products used on City of Madison projects shall be constructed of 100 percent biodegradable materials, including stitching. There are four Types of Class I erosion mat.

**URBAN TYPE A** shall have a minimum permissible shear stress of 1.0 lbs/ft<sup>2</sup> for non-netted materials. No specified minimum permissible shear stress for netted products. Recommended for use on slopes 4:1 or flatter, and recommended for use in environmentally sensitive areas. Not recommended for use in channels.

**URBAN TYPE B** shall have a minimum permissible shear stress of 1.0 lbs/ft<sup>2</sup>. Recommended for use on slopes of 2.5:1 or flatter, and recommended for use in environmentally sensitive areas. Not recommended for use in channels.

*Note: All products listed in the PAL as Class I Urban Type A and Class I Urban Type B are 100 percent organic.*

**TYPE A ORGANIC** shall have a minimum permissible shear stress of 1.0 lbs/ft<sup>2</sup>. Recommended for use on slopes of 2.5:1 or flatter. Not recommended for use in channels. Only products that are constructed of 100 percent biodegradable matting, netting, and stitching will be permitted.

**TYPE B ORGANIC** shall have a minimum Permissible Shear Stress of 1.5 lbs/ft<sup>2</sup> (70) Pa. Recommended for use on slopes of 2:1 for flatter. Only products that are constructed of 100 percent biodegradable matting, netting, and stitching will be permitted.

**CLASS II** Class II erosion mats shall be long lasting, organic ECRM mats. Class II mat shall have an expected working duration of a minimum of three (3) years. All Class II products used on City of Madison projects shall be constructed of 100 percent biodegradable materials, including stitching. There are two acceptable Types of Class II erosion mats.

**TYPE A ORGANIC** shall be a jute fiber mat. This type of matting shall only be used to reinforce sod and shall conform with Section 628.2.2 of the Wisconsin Department of Transportation Standard Specifications.

**TYPE B** shall not be permitted on City of Madison projects.

**TYPE C ORGANIC** shall have a Minimum Permissible Shear Stress of 2.0 lbs/ft<sup>2</sup> (95 Pa). Type C shall be 100% biodegradable including all netting used in its construction. Recommended for used on slopes of 2:1 or flatter, or in channels. Recommended for use in environmentally sensitive areas.

**CLASS III** Class III erosion mat shall be a 100% synthetic mat which shall be UV stabilized. There are four Types of Class III erosion mat.

**TYPE A** is an ECRM mat and shall have a Minimum Permissible Shear Stress of 2.0 lbs/ft<sup>2</sup> (95 Pa). Recommended for used on slopes of 2:1 or flatter, or in channels.

**TYPE B** is a Turf Reinforcement Mat (TRM) and shall have a Minimum Permissible Shear Stress of 2.0 lbs/ft<sup>2</sup> (95 Pa). Recommended for used on slopes of 2:1 or flatter, or in channels.

**TYPE C** is a TRM and shall have a Minimum Permissible Shear Stress of 3.5 lbs/ft<sup>2</sup> (170 Pa). Recommended for used on slopes of 2:1 or flatter, or in channels.

**TYPE D** is a TRM and shall have a Minimum Permissible Shear Stress of 5.0 lbs/ft<sup>2</sup> (240 Pa). Recommended for used on slopes of 1:1 or flatter, or in channels.

Note: When Class III, Types B, C or D are used, the affected areas shall be seeded and fertilized but not mulched. The affected area shall then have Class I matting installed over the affected area. The seeding and Class I matting will be measured and paid for separately.

### **210.3 Construction Methods.**

#### **210.3(a) Polymer Stabilization.**

Application is intended to be done with conventional hydraulic seeding equipment. Polyacrylamide Soil Stabilizer may also be placed through dry spreading.

Application rates shall be as recommended by the manufacturer and shall meet the approval of the engineer. In general, rate of application shall be 20 lbs./acre.

#### **210.3(b) Erosion Matting.**

Erosion mat shall be installed in compliance with the Standard Plate "EROSION MAT" in the City of Madison Standard Specifications for Public Works Construction and/or in compliance with the manufacture's specifications. Erosion matting shall be installed within three (3) days of seeding.

The Contractor shall submit the name of the specified product proposed for use as well as the manufacturer's recommended installation instructions, including but not limited to: recommended anchoring devices, (i.e. type of stakes or staples); overlap; anchor trench configuration; and anchoring pattern. The Contractor shall provide this submittal at the preconstruction meeting. Where any discrepancy exists between installation methods called out on the Standard Plate and the manufacturer's specifications, the Construction Engineer shall have the final authority to specify the installation method used.

### **210.4 Method of Measurement.**

#### **210.4(a) Construction Entrance, Street Construction Entrance Berm.**

Construction Entrance and Street Construction Entrance Berm shall be measured as a completed unit as installed, maintained and removed in the field. The Contractor shall be aware that the Standard Detail Drawings for Construction Entrance (SDD 1.05) and Street Construction Entrance Berms

## Part II - Earthwork

(SDD 1.10) specify these entrances to be a minimum of 50' long. Construction of an entrance not meeting this specification will result in no payment for this item, not a partial payment.

The quantity of clear stone required for these items shall be compensated separately under the clear stone bid item. The Contractor shall furnish and deliver to the Engineer a ticket with each load showing the net weight of the load of clear stone. All tickets for materials delivered to a City of Madison project shall be presented to the City representative on the project within twenty-four (24) hours after delivery of the materials to the project. Tickets presented after the time specified may be rejected due to inability to substantiate actual use of the materials on the project.

Any required restoration resulting from the removal of any Construction Entrance or Street Construction Entrance Berm after project restoration has been completed shall be considered incidental to the entrance item.

### 210.4(b) Clear Stone Berm (Ditch Check), Street Construction Stone Berm.

Clear Stone Berm (Ditch Check) and Street Construction Stone Berm, shall be measured as a completed unit as installed, maintained and removed in the field. Street Construction Stone Berms installed across the full width of the street shall be counted as two (2) units.

The quantity of clear stone required for these items shall be compensated separately under the clear stone bid item. The Contractor shall furnish and deliver to the Engineer a ticket with each load showing the net weight of the load of clear stone. All tickets for materials delivered to a City of Madison project shall be presented to the City representative on the project within twenty-four (24) hours after delivery of the materials to the project. Tickets presented after the time specified may be rejected due to inability to substantiate actual use of the materials on the project.

Any required restoration resulting from the removal of any Clear Stone Berm (Ditch Check) or Street Construction Stone Berm after project restoration has been completed shall be considered incidental to the stone berm item.

### 210.4(c) Erosion Matting.

Erosion Matting shall be measured by the square yard in place not including runout in anchor trenches or overlap.

### 210.4(d) Terrace Restoration.

Terrace Restoration shall be measured by the square yard or the trench foot as specified in the contract.

## **210.5 Basis of Payment.**

### 210.5(a) Clear Stone.

The quantity of clear stone for Clear Stone Berm (Ditch Check), Street Construction Stone Berm, Construction Entrance, and Street Construction Entrance Berm shall be paid at the contract unit price per ton and compensated for under the clear stone bid item.

210.5(b) Silt Fence, Silt Sock, Erosion Bales.

Silt Fence - Complete (BID ITEM 21021), Silt Sock (8 inch) – Complete (BID ITEM 21017), Silt Sock (12 inch) – Complete (BID ITEM 21024), and Erosion Bales - Complete (BID ITEM 21027) shall be paid for at the contract unit price per linear foot, which price shall be full compensation for furnishing all materials; for constructing, reconstructing, erecting, re-erecting, maintaining, removal and any follow-up restoration; and for all labor, tools, equipment and incidentals necessary to complete the work. Half of the installed quantity shall be paid at the time of installation and the remaining half shall be paid upon removal and any required incidental restoration is completed.

Where silt fence, silt sock and erosion bales are not listed as an item on which to submit unit prices, it shall be understood and agreed that the Contractor shall be paid two dollars and fifty cents (\$2.50) per linear foot of silt fence, erosion bales, or silt sock furnished, installed, maintained and removed.

210.5(c) Inlet Protection.

Inlet Protection, Type C - Complete (BID ITEM 21031), Inlet Protection, Type C Modified - Complete (BID ITEM 21035), Inlet Protection, Type D - Complete (BID ITEM 21041), Inlet Protection, Type D Modified - Complete (BID ITEM 21045), and Inlet Protection, Type D Hybrid – Complete (BID ITEM 21055), shall be paid for at the contract unit price per each unit installed in the field, which price shall be full compensation for furnishing all materials; installing, reinstalling, maintaining, removal and any follow-up cleanup; and for all labor, tools, equipment and incidentals necessary to complete the work. Half of the installed quantity shall be paid at the time of installation and the remaining half shall be paid upon removal and any follow-up cleanup has been completed.

210.5(d) Erosion Matting.

The area of erosion matting, measured as provided above, shall be paid for at the contract unit price per square yard for erosion matting, which price shall be full compensation for furnishing and placing all materials; for constructing, reconstructing, maintaining and anchoring; and for all labor, tools, equipment and incidentals necessary to complete the work. Any matting installed incorrectly shall result in all matting be paid at half the contract price. Incorrectly installed matting shall be defined as matting which is not installed in compliance with the conditions as laid out in these standard specifications. Seeding is not included in this item and will be measured and paid separately per Section 207 of these Standard Specifications.

## **ARTICLE 211 - TERRACE RAIN GARDEN**

---

### **211.1 Description.**

Work under this item shall include all work (including but not limited to excavation, removal and disposal of existing material, provision and placement of engineered material and construction of curb cut), all materials (including but not limited to engineered fill, clear stone, concrete, and landscape fabric), labor, and incidentals required to construct the rain garden system meeting the sizes, locations, specifications, and detail drawings contained in this document and in the plan set.

The Contractor shall review the detail drawings for each system in detail. The size of each garden is specific as is the means of providing stormwater to the system. This item does not include planting of the rain garden system. Planting will be completed by others.

The City reserves the right to add or remove rain gardens from the contract. The Contractor shall not be compensated in any matter for the removal or addition of rain gardens from the contract. The addition of rain gardens shall be consistent with the already designed gardens as indicated in the plan set.

### **211.2 Materials.**

The provisions of all materials necessary for the complete construction of the rain garden shall be included in the bid price.

#### **211.2(a) Engineered Soil**

The soil mixture shall consist of a mixture of sand, compost and topsoil. The mix shall be designed to approximate the following percentages, by volume. The mix shall be free of rocks, stumps, roots, brush or other material over 1 inch in diameter. No other materials shall be mixed with the planting soil that may be harmful to plant growth or prove a hindrance to planting or maintenance.

<b>Engineered Soil Component</b>	<b>% Composition by Volume</b>
Sand	45-55%
Topsoil	10-15%
Compost	30-50%

#### **211.2(a)(1) Sand**

The sand used in the engineered soil mix shall meet the following gradation requirements:

1. Crushed & screened sandstone
2. 100% passing a #4 sieve
3. Maximum of 5% passing a #200 sieve

#### **211.2(a)(2) Topsoil**

The topsoil component shall be a USDA classified sandy loam, loamy sand or loam texture. The topsoil component textural class shall be verified by a laboratory analysis or a professional acceptable to the jurisdiction having authority. The topsoil shall be pulverized prior to mixing with

## Part II - Earthwork

the other materials. No soil particle size over 1" diameter shall be accepted and will require removal of all material from the site and a new mix being provided.

### 211.2(a)(3) Compost

The compost component shall meet the following requirements:

1. Particle Size – 98% of the compost shall pass through a 0.75-inch screen.
2. Physical Contaminants – Less than 1% combined glass, metal and plastic.
3. Organic Matter/Ash Content – At least 40% organic matter; less than 60% ash content.
4. Carbon to Nitrogen Ratio – 10-20:1 C:N ratio.
5. pH – Between 6 and 8.
6. Soluble Salts – Electrical conductivity below 10 dS m<sup>-1</sup> (mmhos cm<sup>-1</sup>)
7. Moisture Content – Between 35% and 50% by weight.
8. Maturity – The compost shall be resistant to further decomposition and free of compounds, such as ammonia and organic acids, in concentrations toxic to plant growth.
9. Residual Seeds & Pathogens – Pathogens and noxious seeds shall be minimized.
10. Pathogens – The compost shall meet the Class A requirements for pathogens as specified in s. NR 204.07(6)(a), Wis. Adm. Code.
11. Other Chemical Contaminants – The compost shall meet the high quality pollutant concentrations as specified in s. NR 204.07(5)(c), Wis. Adm. Code.

### 211.2(a)(4) 3-Inch Clear Stone.

Clear Stone shall conform to gradation no. 1, as specified in Section 401.1(b) – Materials.

### 211.2(a)(5) Landscape Fabric.

Landscape fabric shall be 3oz or heavier and shall be resistant to ultraviolet degradation. Alternate materials, such as geotextile fabric, may be approved for installation by the Engineer. Alternate materials shall not be placed prior to approval from the Engineer.

## **211.3 Construction Methods.**

### 211.3(a) Excavation, Fill, Grading.

Construction shall include all excavation, removal and disposal offsite, at a location provided by the Contractor, of existing material to the bottom of rain garden system grade shown on the detail drawings.

Standard excavation shall begin at the outer polygon shown on the detail drawings and shall be on a continuous slope from the existing elevation to the finish horizontal location and elevation as depicted by the inner polygon. This inner polygon represents the bottom of the rain garden. Excavation below finish grade and replacement of existing material with engineered soil is required only below the inner polygon. Excavation below finish grade inside the inner polygon shall consist of two (2) feet of excavation below the finish grade shown on the detail drawings. This volume shall then be filled with engineered soil, as defined in 211.2(a), to the finish grade noted on the detail.

Clear stone shall be sloped at a consistent grade and shall provide adequate drainage for the curb cut. A layer of filter fabric shall be placed between the existing soil and clear stone.



The Contractor is responsible for the provision of all required engineered fill, as called out on the typical section, including compost, topsoil, sand, clear stone, and landscape fabric. All finishing work required to provide a finished engineered soil layer prior to placement of landscape fabric shall be included in this bid item.

**211.3(b) Utilities.**

All ULO's needed to construct each rain garden; there are utilities (gas, sanitary & water) near or in all of these features. All work necessary to locate and work around these utilities is included in the price for these items. If any utility is located within the excavation depths of engineered fill, the contractor shall excavate with caution and use proper construction methods. The contractor shall install Rock Shield around the existing utility to provide protection and shall be included in this item.

If a water valve is located within the limits of the rain garden, this item shall include all materials, labor, and incidentals required to lower the top of the valve such that it is flush with the new finished grades of the rain garden.

**211.3(c) Curb Cut.**

The Contractor shall install 2-foot curb cuts at the locations specified in the plan set. The curb cuts shall be made before the concrete has set. Curb cuts shall not be constructed by cutting fully cured concrete. The curb cut opening shall be flush with the flow line of the curb and provide positive drainage to the rain garden.

**211.4 Method of Measurement.**

Terrace Rain Garden shall be measured by the square foot of garden installed in the field. This measurement shall begin at the outside limits of the Rain Garden as shown on the detail drawing included in the plan set or as directed in the field

**211.5 Basis of Payment.**

Terrace Rain Garden shall be measured as described above which shall be full compensation for all work, materials and incidentals necessary to install the rain garden as described above. Planting shall be completed by others.

## ARTICLE 212 - RIPRAP

### 212.1 Description.

This item shall consist of furnishing and placing riprap in accordance with these specifications, the Contract, as shown on the plans and cross sections, or as directed by the Engineer. The work shall be done at the locations and to the lines and grades as shown on the plans or as directed by the Engineer.

### 212.2 Materials.

#### 212.2(a) Riprap Stone.

Riprap stone shall be durable field or quarry stone that is sound, hard, dense, resistant to the action of air and water, and free of seams, cracks, or other structural defects. Use stone pieces with a length and width no more than twice the thickness. Stone pieces for riprap are subject to approval by the Construction Engineer.

The Construction Engineer shall determine the average dimension of stone pieces by averaging measurements of thickness, width, and length. Furnish stones conforming to the size requirements for the riprap grade the plans show. Size requirements are expressed as the percent of the gross in-place riprap volume occupied by stones within average dimension size ranges for each riprap grade as follows.

Average Dimension Ranges For Each Riprap Grade				Fraction Of Gross In-Place Riprap Volume Occupied By Stones
Light Riprap	Medium Riprap	Heavy Riprap	Extra-Heavy Riprap	
inches	inches	inches	inches	
> 16	> 20	> 25	> 30	0%
11-13	14-16	18-20	22-25	10%-14%
9-11	11-14	14-18	18-22	15%-21%
4-9	5-11	6.5-14	8-18	20%-28%
< 4	< 5	< 6.5	< 8	5%-7%
< 1	< 1	< 1	< 1	1% or less

#### 212.2(b) Riprap Grout.

Riprap grout shall be an air-entrained Portland cement mortar or concrete to fill the voids between riprap stones in grouted riprap. Conform to the physical requirements for component materials as specified in section 501.2 of the latest edition of Standard Specifications for Highway and Structure Construction of the State of Wisconsin, Department of Transportation except furnish fine aggregate or a combination of fine and coarse aggregate with a gradation that results in a grout with a consistency that allows complete filling of the riprap voids.

Grout shall conform to the following mixture requirements:

- Contains 470 pounds or more of Portland cement per cubic yard of grout. The Contractor may substitute class C fly ash for up to 30% of required Portland cement.

## Part II - Earthwork

- Contains only enough water to achieve a three (3) inch slump. Any additional workability required to completely fill the riprap voids must be achieved with admixture without increasing the water/cement ratio.
- Contains 9% or more air for mixes with a nominal top size aggregate less than 3/8 inch or 7% or more air for a mix with 3/8 inch or larger aggregate.

### **212.3 Construction Methods.**

#### 212.3(a) General.

Prepare a bed for the riprap by excavating, shaping the slopes, and constructing the toe for riprap installation. After placing the riprap, restore the surface of adjacent work and dispose of surplus material.

#### 212.3(b) Riprap.

Stone shall be laid with close broken joints and shall be firmly bedded in the slope and against the adjoining stones. The stones shall be laid perpendicular to the slopes with ends in contact. The Riprap shall be thoroughly compacted as construction progresses and the finished surface shall present an even, tight surface. The larger stone shall be placed in lower course. Interstices between stones shall be chinked with spall firmly rammed into places. All riprap shall be laid on filter fabric as described, which shall be paid for separately under that item.

Unless otherwise specified, light riprap shall be a minimum of 12 inches thick, medium riprap a minimum of 18 inches thick, heavy riprap a minimum of 24 inches thick and extra-heavy riprap a minimum of 30 inches thick. All riprap thicknesses shall be measured perpendicular to the bed slope.

#### 212.3(c) Placing Grouted Riprap.

If the plans specify using grouted riprap, stone shall be laid as specified above under 211.3(b). Fill the spaces between the stones with cement mortar. Use sufficient mortar or concrete to completely fill all voids, except leave the face surface of the stone exposed.

Place grout from the bottom to the top and then sweep the surface with a stiff broom.

### **212.4 Method of Measurement.**

#### 212.4(a) Riprap.

Riprap shall be measured by the cubic yards or ton in place as specified in the contract.

#### 212.4(b) Grouted Riprap.

Grouted riprap shall be measured by the cubic yard of riprap or ton of riprap in place as specified in the contract. Grout required shall be considered incidental to this item and not measured.

### **212.5 Basis of Payment.**

Riprap, measured as provided above, shall be paid for at the contract price unit price. Such payment shall be considered full compensation for furnishing, hauling, placing, and compacting the specified

## Part II - Earthwork

material, including all equipment, tools, labor and incidentals necessary to complete the work as specified. Grout shall be considered incidental to riprap and not be paid for.

## **ARTICLE 213 - MISCELLANEOUS**

---

### **213.1 General.**

This article shall consist of miscellaneous work in accordance with these Specifications, the Contract, as shown on the plans and cross sections, or as directed by the Engineer. The work shall be done at the locations and to the lines and grades as shown on the plans or as directed by the Engineer.

### **213.2 Description**

#### **213.2(a) Mailboxes.**

The mailboxes shall be removed from each driveway and temporary placed at one end of the project limits. The temporary placement location will be determined by the City Construction Engineer. Access will be provided to the temporary placement location area at all times. At the end of the project, the contractor shall re-install the mailboxes to their original location or a location determined by the City Construction Engineer. The contractor shall replace the original post and mailbox if any damage occurs.

### **213.3 Method of Measurement.**

Unless otherwise provided, this work will be measured in the original position of the structures to be removed and replaced, as follows:

1. Remove and Replace mailbox shall be measured by each completed unit in place.

### **213.4 Basis of Payment.**

Remove and Replace Mailbox shall be paid at the contract price for work as described and measured above including all work, materials, labor, and incidentals.

## Part III - Concrete and Concrete Structures

ARTICLE 301 - CONCRETE AND CONCRETE MATERIALS.....	1
301.1    General.....	1
301.2    Concrete Tests.....	2
301.3    Reinforcing Steel.....	3
301.4    Expansion Filler.....	4
301.5    Placing and Finishing.....	4
301.6    Forms.....	6
301.7    Curing.....	7
301.8    Protection of the Concrete.....	7
301.9    Concrete Slurry.....	9
301.10   Concrete Waste Management.....	10
ARTICLE 302 - CONCRETE CURB AND GUTTER.....	12
302.1    General.....	12
302.2    Construction Methods.....	12
302.3    Measurement and Payment.....	14
ARTICLE 303 - CONCRETE SIDEWALKS, CONCRETE DRIVEWAYS, CONCRETE MOUNTABLE MEDIAN ISLAND NOSE AND STEPS OF CONCRETE MASONRY.....	16
303.1    General.....	16
303.2    Construction Methods.....	20
303.3    Measurement and Payment.....	25
ARTICLE 304 - MISCELLANEOUS CONCRETE STRUCTURES.....	28
304.1    General.....	28
304.2    Construction Methods.....	28
304.3    Measurement and Payment.....	30
ARTICLE 305 - SIDEWALK REPLACEMENT PROGRAM.....	31
305.1    General.....	31
305.2    Remove & Replace 5 Inch Concrete Sidewalk-Sidewalk Replacement Program; Remove & Replace 7 Inch Concrete Sidewalk & Drive-Sidewalk Replacement Program.....	33
305.3    Remove & Replace Concrete Steps-Sidewalk Replacement Program.....	34
305.4    Remove Existing Asphalt Sidewalk & Drive-Sidewalk Replacement Program.....	34
305.5    Remove & Replace Concrete Curb & Gutter-Sidewalk Replacement Program.....	35
305.6    Reset Brick Pavers-Sidewalk Replacement Program.....	36
ARTICLE 306 - MISCELLANEOUS.....	37
306.1    General.....	37
306.2    Description.....	37
306.3    Method of Measurement.....	37
306.4    Basis of Payment.....	37

## **ARTICLE 301 - CONCRETE AND CONCRETE MATERIALS**

---

### **301.1 General.**

All concrete used on City of Madison Public Works projects shall comply with the following Subsections of Article 501, "Concrete" of the latest edition of the Standard Specifications for Highway and Structure Construction of the State of Wisconsin, Department of Transportation, Division of Highways, except as modified herein or in the Special Provisions of the contract:

501.2	Materials
501.3	Construction

All concrete used on City of Madison Public Works projects shall also comply with the following requirements, except as modified in the Special Provisions of the contract. Where the following requirements conflict with the above latest edition of the Standard Specifications for Highway and Structure Construction of the State of Wisconsin, Department of Transportation, then these following requirements apply:

1. The minimum compressive strength at twenty-eight (28) days shall be three thousand (3,000) pounds per square inch. The minimum modulus of elasticity at twenty-eight (28) days shall be three million one hundred twenty thousand (3,120,000) pounds per square inch.
2. The minimum cement content shall be six (6) bags per cubic yard, except for concrete mixes with fly ash. Each bag of cement shall contain ninety-four (94) pounds net.
3. From the master limits of the job mix, adjusted as necessary for the specific gravities of the aggregate furnished, the Contractor shall determine and submit to the City Engineer a job mix, using the lowest quantity or percentage of fine aggregate within the range shown therefor which, without exceeding the maximum quantity of water permitted, will yield a mix possessing the necessary workability. The Contractor may use concrete from a pre-approved Supplier without submitting a mix design .

Contractor shall submit a mix design for concrete annually, when a change of aggregate sources or mix design is made or as directed by the Engineer.

4. All concrete shall be Air-Entrained, and shall contain seven (7) percent air by volume, plus or minus one and one-half (1.5) percent.
5. All concrete for curb and gutter, sidewalks, floors, roof slabs, and other horizontal pours shall have a slump of not less than two (2) inches and not more than four (4) inches. All concrete for walls, columns, and other vertical pours shall have a slump of not less than three (3) inches and not more than six (6) inches.
6. No water shall be added when placing concrete unless approved by the Engineer. If water is added without consent of the Engineer, this shall be considered sufficient grounds for rejecting the concrete.
7. The maximum limit of light chert (specific gravity of 2.40 or less) allowed in coarse aggregate shall be three (3) percent by weight.

8. Admixtures other than required for air entrainment shall not be used unless approved by the Engineer for a specific project.

### **301.2 Concrete Tests.**

Tests shall be made as directed by the Engineer to assure compliance with these Specifications. Tests shall be made in accordance with the requirements of Article 106 - Control of Materials, of these Specifications, and as specified below.

1. Slump tests shall be made following the “Methods of Test for Slump of Portland Cement Concrete” (ASTM C-143). Slump tests shall always be made from the same batch of concrete from which strength tests are made, and may be made when strength tests are not made.

Air content tests shall be made in accordance with the “Method of Test for Air Content of Freshly Mixed Concrete by the Pressure Method” (ASTM C-231). Air content may also be checked by the use of approved Air Content Indicators.

If the measured slump or air content falls outside the specified limits, a check test shall be made immediately on another portion of the same sample. In the event of a second failure, the concrete shall be considered to have failed to meet the Specifications and shall not be used in the work. Any concrete from the same batch from which the tests were made which has been placed shall be removed and disposed of by the Contractor at the Contractor’s expense.

2. Strength tests shall be made for each of the following conditions: each day’s pour; each class of concrete; each change of source of supply; or when ordered by the Engineer. A strength test shall consist of a minimum of two (2) standard six (6) inch concrete cylinders for each one hundred fifty (150) cubic yards of concrete or fraction thereof placed on any day.

The City representative shall make the cylinders following the “Method of Making and Curing Concrete Compression and Flexure Test Specimens in the Field” (ASTM C-31). The cylinders will be tested by the City at its own expense at seven (7) days or at twenty-eight (28) days, unless otherwise specified, in accordance with the “Method of Test for Compressive Strength of Molded Concrete Cylinders” (ASTM C-39). The Contractor shall furnish all materials, labor, and equipment necessary for fabricating, preparing, protecting, and transporting all required samples, including concrete, cylinder molds, and wooden boxes suitable for the protection and transportation of the samples.

In the event test cylinders show the compressive strength of the concrete to be below the specified compressive strength of concrete, the following procedure shall be followed:

- a. Three (3) cores shall be taken for each cylinder test below the specified compressive strength of concrete. Cores shall be taken in accordance with the “Standard Methods of Securing, Preparing and Testing Specimens from Hardened Concrete for Compressive and Flexural Strengths” (ASTM C-42), from the area of the pour represented by the defective cylinders. These cores shall be tested as prescribed in Section 4 of the “Method of Test for Compressive Strength of Molded Concrete Cylinders” (ASTM C-39) in order to verify the cylinder tests.



- b. Where the cores show the compressive strength of the concrete to equal or exceed the specified compressive strength of concrete, the pour in question shall be accepted, and the costs of obtaining and testing cores shall be borne by the City.
  - c. Where the average of the cores tested show the compressive strength of the concrete to be below the specified compressive strength of concrete and equal to or greater than eighty-five (85) percent of the specified compressive strength of concrete and if no single core is less than seventy-five (75) percent of the specified compressive strength of concrete, the City shall deduct from any monies due or to become due the Contractor an amount equal to ten (10) percent of the contract price of the structure or portion thereof, in which the defective concrete is incorporated. The Contractor shall also bear the costs of obtaining and testing the cores.
  - d. Where the average of the cores tested show the compressive strength of the concrete to be below eighty-five (85) percent of the specified compressive strength of concrete, or if a single core is less than seventy-five (75) percent of the specified compressive strength of concrete, the structure or portion thereof, in which the defective concrete is incorporated shall be removed and disposed of by the Contractor at the Contractor's expense. The Contractor shall also bear the costs of obtaining and testing the cores.
3. Tests of the concrete proposed for use on the project shall be made at the direction of the Engineer in accordance with the "Methods of Test for Compressive Strength of Molded Concrete Cylinders" (ASTM C-39) and the "Method of Making and Curing Concrete Compression and Flexure Test Specimens in the Laboratory" (ASTM C-192). Six (6) standard six (6) inch cylinders, three (3) to be tested at seven (7) days and three (3) to be tested at twenty-eight (28) days, shall be made with the proportioning and materials proposed to be used in the major part of the project.

The slump should not be less than the greatest slump expected to be used in the structure. The tests made on the aggregate required herein may be made a part of these tests if suitably referenced on the reports which shall be issued at seven (7) days and at twenty-eight (28) days. These tests shall be repeated as necessary due to changes in materials or unsatisfactory results.

### **301.3 Reinforcing Steel.**

All reinforcing bars shall be deformed, and the type used in the work under these Specifications shall be subject to the approval of the Engineer.

1. Where directed by the Engineer the Contractor shall install reinforcing steel in concrete sidewalks, driveways, sidewalk ramps, curb and gutter, special waterways, footings, walls, and other structures. Such reinforcing steel will be measured by length in linear feet of the sizes ordered and installed. In the absence of applicable unit prices for the particular size(s) of reinforcing steel installed, the unit price(s) for the particular size(s) installed shall be arrived at as follows:
  - a. In proportion to the ratio of the cross sectional area of the size of reinforcing steel installed to the cross sectional area of the smallest size of reinforcing steel included in the contract as a bid item, or

- b. In the absence of a unit price included in the contract as a bid item, in proportion to the ratio of the cross sectional area of the reinforcing steel installed to the cross sectional area of #4 (1/2 inch diameter) reinforcing steel, with a unit price of seventy-five (\$0.75) cents per linear foot for uncoated bars, and one (\$1.00) dollar for epoxy-coated bars.

## 2. Epoxy/Water Proofing

Where epoxy coated reinforcing steel is specified by the contract, the Contractor shall have the option of using a concrete additive in place of the epoxy coating.

Specifically, the Contractor shall provide and incorporate to the concrete mix – XYPEX ADMIX C-1000 to all concrete being used where epoxy coated steel was required by contract.

The Contractor shall be aware that this is not a mix and match option for a given structure. Once a decision is made to switch from epoxy coating to an ADMIX for a given structure, the ADMIX shall be used for all pours and in all concrete for that structure.

The ADMIX shall be used at rates in the concrete mix in accord with the manufacturers recommendations.

### **301.4 Expansion Filler.**

The filler shall be nonextruding and have the same shape and dimensions as the section in which it is installed.

All materials for expansion joints shall be furnished and installed by the Contractor and the costs shall be included in the unit prices bid for the various items of work.

### **301.5 Placing and Finishing.**

Retempering of mortar or concrete which has partially hardened, that is mixing with additional materials or water, shall not be permitted.

No concrete shall be deposited in water or mud. During the pouring of bottom slabs and walls, the Contractor shall furnish sufficient pumping equipment to keep the water below the bottom of the floor of the structure. After concrete has been poured the Contractor shall keep the pumping equipment in continuous operation for thirty-six (36) hours.

Concrete shall not be deposited on frozen subbase material, on or against ice or frost, or on reinforcing steel having a temperature at pouring time of less than 36°F.

Do not resume concreting operations until an ascending air temperature in the shade and away from artificial heat reaches 32°F.

Concrete when deposited shall have a temperature of not less than 55°F. and not more than 100°F.

Concrete shall be handled from the mixer to placement as rapidly as practicable and in a manner that will prevent segregation of the ingredients until the unit of operation, approved by the Engineer, is completed. It shall be deposited in the forms as nearly as practicable in its final position to avoid rehandling. Concrete as it is deposited shall be puddled with suitable tools or equipment until forms are completely filled and reinforcement and embedded fixtures thoroughly incorporated in the mass.

Concrete adjacent to the forms, joints, or structures shall be deposited and spaded or vibrated in a manner to prevent the formation of voids or rock pockets. All cavities produced by the removal of form ties and any voids or rock pockets of more than casual occurrence found after the forms are removed, shall be filled immediately with a well mixed grout, composed of one (1) part of Portland cement and three (3) parts of fine aggregate (masonry sand) and finished to the true surface of the face of structure by the following method: Defective areas shall be chipped away to a depth of not less than one (1) inch measured at right angles to the surface. The area shall be thoroughly wetted, brushed with grout, and patched with grout. The patch shall be cured as specified for concrete structures. Defects appearing on the patch shall be repaired at the Contractor's expense.

An accumulation of water on the surface of freshly deposited concrete shall immediately be removed in a manner satisfactory to the Engineer.

Concrete shall be so deposited as to maintain, until the completion of the unit, a plastic surface, approximately horizontal. Forms for walls or other thin sections a height in excess of eight (8) feet shall be provided with openings, or other devices, that will permit the concrete to be placed in a manner that will avoid accumulation of hardened concrete on the forms or metal reinforcement. Under no circumstances shall concrete that has partially hardened be deposited in the work.

When concrete is conveyed by chuting, the mixer shall be of such size and design as to insure a practically continuous flow in the chute. The angle of the chute with the horizontal shall be such as to allow the concrete to flow without separation of the ingredients. An angle of twenty-seven (27) degrees, or one (1) vertical to two (2) horizontal, is the minimum slope which is considered permissible. Chuting through a vertical pipe is satisfactory when the lower end of the pipe is maintained four (4) feet or less above the surface of the deposit. The delivery end of the chute shall be within four (4) feet of the point of deposit. When the operation is intermittent, the spout shall discharge into a hopper. The chute shall be thoroughly flushed with water before and after each run; the water used for this purpose shall be discharged outside the forms but not into paved streets, walks, gutters or inlets.

All reinforced concrete shall be vibrated in place to the satisfaction of the Engineer with mechanical vibrators. Vibrators shall also be required for non-reinforced concrete structures when other methods of compaction or "puddling" do not give the desired results in the opinion of the Engineer.

Before depositing new concrete on or against concrete which has been set, the forms shall be retightened, the surface of the set concrete shall be roughened as required by the Engineer, thoroughly cleaned of foreign material and saturated with water.

Joints not indicated on the plans shall be so designed and located as to least impair the strength and appearance of the structure. All joints shall provide sufficient resistance to shear to which they may be subjected. Horizontal joints required to be watertight shall be constructed by forming continuous keyways in the lower portion of the concrete before the concrete has hardened. Before placing the superimposed concrete, the joint shall be thoroughly cleaned of foreign material and saturated with

water. Vertical joints required to be watertight, and expansion joints shall be provided with suitable keyways subject to the approval of the Engineer.

Top surfaces of roof slabs, unless otherwise specified, shall be smoothed with a wood float. Care shall be taken to avoid an excess of water in the concrete, and to drain or otherwise promptly remove any water that comes to the surface. Dry cement or a dry mixture of cement and sand, shall not be sprinkled directly on the surface.

Top surfaces of concrete floor slabs, unless otherwise specified, shall be wood floated and then troweled with a steel hand trowel or a mechanically operated steel trowel to a smooth, dense finish. Steel troweling shall be done after the water has disappeared from the surface.

Unless otherwise specified, all edges of concrete along joints and forms shall be finished with a steel edging tool of one-fourth (1/4) inch radius.

Where concrete is to be placed in two lifts, as for cunettes, pavements, and other structures with wire mesh reinforcements, the concrete for the lower lift shall be placed, the required reinforcement positioned and secured and the upper lift of concrete placed. Any portion of the lower lift of concrete not covered with the upper lift of concrete within thirty (30) minutes after being placed, shall be removed. Concreting operations shall be discontinued due to insufficient natural light, unless an adequate and approved artificial lighting system is provided and operated.

### **301.6 Forms.**

Forms shall conform to the shape, lines and dimensions of the structure as called for on the plans.

For exposed concrete surfaces, forms shall be three-fourths (3/4) inch structural plywood or acceptable prefabricated commercial wood or steel form panels. Forms used for exposed surfaces are subject to the approval of the Engineer.

Joints in forms shall be horizontal or vertical. For unexposed surface and rough work, undressed lumber may be used. Lumber once used in forms shall have nails drawn, and surfaces to be in contact with concrete shall be thoroughly cleaned before being used again. All form work shall be checked for plumbness, alignment, and position by the Engineer before concrete placement begins.

Forms shall be substantially tight to prevent leakage of mortar; they shall be properly braced or tied together so as to maintain position and shape. If adequate foundation for shores cannot be secured, trussed supports shall be provided.

Unless otherwise specified or directed, suitable moulding or bevels shall be placed in the angles of forms to round or bevel the edges of the concrete.

The inside of forms shall be coated with nonstaining mineral oil or other approved material before each use and thoroughly wetted (except in freezing weather). Oil shall be applied before reinforcement is placed and shall be kept from contact with concrete already placed to which fresh concrete is to be bonded.

Temporary openings shall be provided where necessary to facilitate cleaning and inspection immediately before placing concrete.

Forms shall not be disturbed until the concrete has hardened. Shoring shall not be removed until the member has acquired sufficient strength to safely support its weight and the load upon it. Members subject to additional loads during construction shall be shored adequately to support both the members and the construction loads in such a manner as will protect the member from damage by the loads. This shoring shall not be removed until the member has acquired sufficient strength to safely support its weight and the load upon it, and then only with the approval of the Engineer.

After removal of forms, all metal devices used to tie forms together and hold them to correct alignment and location shall be removed in such a manner that no metal shall remain within less than one (1) inch of the surface of the concrete. The method of removal of such ties shall be such as not to cause injury to the surface of the concrete. The Contractor shall not burn off bolts, rods, or other metal devices. After the removal of such ties, the opening shall be roughened and all concrete containing any oil removed. The cavities produced shall be filled as specified in Section 301.5.

**301.7 Curing.**

Exposed surfaces shall be protected from drying for a period of at least seven (7) days as per Section 415.3.12 of the latest edition of the Standard Specifications for Highway and Structure Construction of the State of Wisconsin, Department of Transportation, except as modified herein or in the Special Provisions of the contract. Curing compound shall be white pigmented.

**301.8 Protection of the Concrete.**

301.8(a) Cold Weather Protection.

All concrete used for sidewalk, curb and gutter, pavement, bridges, culverts, retaining walls, access structures, catchbasins, inlets, or any other structure consisting wholly or in part of concrete, when placed during cold weather shall be mixed, placed, and protected in accordance with the requirements prescribed in Subsection 501.3.9 “Mixing and Protection During Cold Weather” of Standard Specifications for Highway and Structure Construction of the State of Wisconsin, Department of Transportation.

Section 415.3.15.2 of the Standard Specifications for Highway and Structure Construction of the State of Wisconsin, Department of Transportation shall be revised as follows:

<b>Predicted or Actual Air Temperature</b>	<b>Minimum Equivalent Level of Protection</b>
22 to 32 F (-6 to <0 C)	single layer of polyethylene
17 to 22 F (-8 to < -6 C)	double layer of polyethylene
< 17 F (< -8)	6” of loose, dry straw or hay between 2 layers of polyethylene

Regardless of the precautions taken, the Contractor shall be responsible for the protection of the concrete placed, and any concrete damaged by freezing or frost action during the first seven (7) days following its placement shall be removed and replaced by the Contractor at the Contractor’s expense.

Under no circumstances shall concrete be ordered or delivered for the project, until such time as the equipment and materials for protecting and heating the concrete, as described above, are on the job site in sufficient quantity to obtain the desired results.

301.8(b) Bridges, Box Culverts and Roof Slabs.

In the determination by the Engineer, of the time for the removal of falsework, consideration shall be given to the location and character of the structure, to the weather and other conditions influencing the setting of the concrete and to the materials used in the mix.

The Engineer reserves the right to determine the time when falsework or form supports may be removed either by the use of test cylinders or by the use of the minimum requirements shown below.

Falsework supporting concrete structures shall remain in place in accordance with the following minimum requirements, which shall be exclusive of days in which concrete has been subjected to a temperature of below 40°F.

<b>Span Length - Feet</b>	<b>Air Entrained Concrete</b>	<b>High Early Strength Concrete</b>
12 or less	7 days	3 days
Over 12	14 days	6 days

When operations are controlled by laboratory controlled cylinder tests, the removal of falsework and support forms may be begun, with the approval of the Engineer, when the test of cylinders shown a compressive strength of the concrete of not less than 2,000 lbs./sq. in. for spans twelve (12) feet or less and 2,500 lbs./sq. in. for spans over twelve (12) feet.

Backfilling of walls and over tops of box culverts shall be carried out by the Contractor only with the approval of the Engineer.

301.8(c) Opening Curb and Gutter, Sidewalk, Driveways, and Pavements to Traffic.

Traffic shall be excluded over or on newly constructed curb and gutter, sidewalk, driveways, and pavements for such periods as are hereinafter designated. Where the term “pavement” appears below, it shall be taken to refer to the particular type of construction involved.

The Engineer reserves the right to determine the time when the pavement shall be opened to traffic either on the basis of test cylinders or minimum time periods related to atmospheric temperatures.

When opening of the pavement to traffic is controlled by cylinder tests, the pavement may be opened, after expiration of the curing period or cold weather protection period, as the case may be, when the tests of cylinders show a compressive strength of the concrete of not less than 3,000 pounds per square inch.

At least two cylinders shall be tested in determining the attained strength of concrete for the purpose of opening the pavement to traffic. The average of test results for the two cylinders shall be used to determine compliance, except that neither cylinder may be more than ten percent below the required strength. The cylinders shall be cured under conditions similar to those prevailing for the pavement which they represent.

When the opening is not controlled by cylinder tests, traffic shall be excluded from the newly constructed pavement for such minimum periods as hereinafter designated:

For not less than seven (7) days when the atmospheric temperatures are generally 70°F. or higher during the period.

For not less than ten days when the atmospheric temperatures are generally not lower than 60°F. during the period.

For not less than such a length of time up to twenty-one (21) days as the Engineer may require, taking into consideration the temperatures and protective measures, if any, when the atmospheric temperatures are generally lower than 60°F.

When High-Early-Strength Concrete is used in the work, the above specific periods of seven (7), ten (10) and twenty-one (21) days may be reduced to three (3), four (4) and seven (7) days, respectively, under like conditions.

When Grade A-FA Concrete is used in the work, the specific periods of seven (7) and ten (10) days shall be increased to ten (10) and fourteen (14) days respectively, under like conditions.

In all cases the pavement shall be cleaned, and the joints shall be cleaned and sealed as provided, before traffic of any kind is permitted to use the pavement.

**301.8(d) Catchbasins, Access Structures, and Headwalls.**

Traffic on or over these structures shall be curtailed until the concrete has reached full strength.

Backfilling may proceed after seven (7) days for air entrained concrete or three (3) days for High-Early-Strength concrete. When the Contractor desires to backfill prior to the times specified then the Contractor shall do so at the Contractor's own risk.

**301.9 Concrete Slurry.**

Type A and Type B slurry mixes as listed below shall be used as called for on the plans or as specified in the field by the Engineer on storm or sanitary sewer projects. The above mixes shall conform to the following one (1) cubic yard of mix of flowable slurry:

**Type A Slurry**

3000 lb.	Sand
50 lb.	Portland Cement
300 lb.	Class C Fly Ash
50 gal.	Water
1.4 oz.	Air Entraining Admixture

**Type B Slurry**

2700 lb.	Sand
100 lb.	Portland Cement
300 lb.	Class C Fly Ash
50 gal.	Water

**NOTES:**

1. All design aggregate batch weights are saturated surface dry.
2. Aggregate batch weights shall be adjusted for free moisture at time of mixing.

3. Admixture quantity may be varied within manufactures recommended dosage to provide desired results.

### **301.10 Concrete Waste Management.**

#### General

This work consists of containment, collection, storage and proper disposal of concrete wastes generated by saw cutting or grinding of existing concrete pavements or waste run-off generated during construction of new concrete pavements, particularly exposed aggregate surfaces. Concrete wastes typically are strongly alkaline and may contain other contaminants that can harm plants and are particularly harmful if allowed to enter streams, lakes wetlands or other water bodies through the storm sewer system.

Contractor is alerted that there are local, state and federal regulations governing the handling and disposal of hazardous materials and this Special Provision in no way relieves the Contractor of any responsibility to comply with such regulations. The intent is to provide more specific guidelines for management of concrete wastes on this project and provide a basis of payment for work associated with specific management measures properly implemented.

#### Materials

Contractor may choose appropriate materials to suit his methods of management of wastes with the following minimum requirements. Pre-fabricated washout containers shall be in sound condition and watertight. Site fabricated containment structures shall be constructed below grade if feasible. If constructed above grade they shall be of sturdy materials and designed to provide a minimum of 6 inches of freeboard based on the volume of liquid wastes to be generated between clean-outs. Structure shall be lined with a waterproof plastic sheeting of minimum 10-mil thickness that has no holes or tears. Above grade structures shall have a double layer lining.

Inlet liners used to convert an existing storm inlet into a containment structure shall be shop fabricated and shall consist of a heavy-duty waterproof lining fitted to the inside of a commercially manufactured geotextile sediment trap. The completed inlet containment structure shall be sound and watertight to prevent any leaching into the storm sewer system, and shall be approved by the Engineer prior to accepting any concrete waste water. NOTE: a geotextile sediment trap by itself is not acceptable as the leachate continues to be highly alkaline and contain dissolved contaminants.

#### Construction Methods

If conditions are such that debris and slurry from sawcutting and grinding operations will remain on pavements and not run off into gutters, they may be allowed to dry in place and be cleaned from pavement by sweeping or vacuum equipment. Such wastes shall not be allowed to remain on pavements beyond the end of a day's work.

Slurries from cutting or grinding or wash water from exposed aggregate construction may be directed to exposed (unpaved) areas of the grade provided: 1) such areas are below the surface drainage grade and will not run off into watercourses, gutters, inlets or storm sewers; 2) such areas are planned for pavement or other uses, such that residue following evaporation / percolation will not adversely impact vegetation; 3) disposal area is approved by the Engineer prior to use.



If it is not practical to direct slurry to an appropriate unpaved disposal area it may be directed to a street gutter provided sand bags or other devices are used to contain the slurry on the pavement and prevent its entry into storm sewer inlets. Contractor shall remove such slurry or residue from the pavement prior to the end of each work day by vacuum systems or other methods. Slurry may be pumped to an approved containment structure for on-site storage.

On-site containment structures shall be emptied on a periodic basis, such that they do not exceed their design capacity, including required freeboard. Contractor shall remove contaminated liquids from the site, using trucks fitted with water-tight gaskets to prevent leakage, or other similar methods. Wastes shall be properly disposed of off-site, in accordance with applicable laws and regulations.

If it is not practical to construct or direct slurry to an above-grade containment structure, the contractor may utilize a storm inlet for containment under the following conditions:

- There is no significant chance of precipitation, flows from upstream pipe connections or other reasons requiring the inlet to function for storm water drainage during the period it is to be used for containment
- The Construction Engineer provides prior written approval for each inlet proposed
- Contractor fabricates and properly installs a waterproof liner for each inlet used, in accordance with the requirements herein
- Contractor maintains inlet liners in good condition and periodically empties such structures and disposes of wastes as provided for on-site containment structures
- Contractor completely removes liner and all wastes and restores inlet to its prior functioning condition after its use.

### Measurement and Payment

Work under this Section will be measured as a single, complete unit of work, for all measures and devices used to contain and dispose of concrete wastes throughout the duration of the project, acceptably installed, maintained and removed.

This work, measured as provided, will be paid as incidental to all City of Madison Public Works Contracts, which shall be considered full compensation for designing, furnishing installing, maintaining and removing any on-site containment structures, cleaning slurry or residue from pavements by vacuum or other methods, removal from site and proper disposal of all wastes, and all incidental labor, equipment, tools.

## **ARTICLE 302 - CONCRETE CURB AND GUTTER**

---

### **302.1 General.**

#### 302.1(a) Description.

This work shall consist of constructing concrete curb and gutter, with or without reinforcement, of the dimensions and design as indicated, and placed in one course on the prepared foundation or base, at the locations and to the required lines and grades; all as shown on the plans and provided by the contract.

The Contractor shall mark the top of the curb where the sanitary sewer and water service cross the curb and gutter. The mark may be made by sawcutting. The depth shall be a minimum of one-sixteenth (1/16") inch deep. The laterals and services will be located by the City. The cost of the location marks shall be considered incidental to the cost of the concrete curb and gutter.

All work done in the vicinity of any tree located in the terrace shall be completed in accordance with section 107.13 Tree Protection Specification.

### **302.2 Construction Methods.**

#### 302.2(a) Preparation of Foundation.

The Contractor shall be responsible for replacement with 1-1/2" crushed stone, mechanically compacted, of any material necessary to bring the subbase to grade, where the Contractor has undercut the subbase without the direction of the Engineer.

#### 302.2(b) Forms.

Curb and gutter forms shall be of steel construction and conform to the design of the type of curb and gutter being installed. Wooden forms may be used only with the Engineer's approval on short radius curves and in special cases where accessibility is limited.

All forms shall be free of hardened concrete, mud, dirt, and debris, and shall be free of bends and twists which would make their use unacceptable on the project.

All forms shall be oiled to the satisfaction of the Engineer before depositing or placing concrete in them.

When concrete curb and gutter is constructed on a curve, flexible forms shall be used for all curves having a radius of two hundred (200) linear feet or less.

#### 302.2(c) Placing and Finishing Concrete.

Wherever directed by the Engineer, driveway gutters shall be built instead of regular curb and gutters.

The curb and gutter over ditches shall be installed in twenty (20) foot lengths centered over the ditch. A dummy joint shall be cut at the center of the twenty (20) foot section.

Unless otherwise specified, curb and gutter shall be installed in minimum lengths of six (6) feet and maximum lengths of fifteen (15) feet.

The Contractor shall install a header at the end of each pour. At no time shall the Contractor be allowed to spread excess concrete as a base for the next or any succeeding pour.

Wherever different types of curb and gutter are employed, the Contractor shall take care that transitions from one type of curb and gutter to another type are done smoothly without loss of flow line grade or curb head shape.

The reconnection of existing drains from adjacent properties to the curb and gutter shall be incidental to concrete curb and gutter.

The slope of the curb and gutter shall not exceed 1" in 12" thru handicap accessible ramps.

Hand formed concrete curb and gutter will be paid for at the unit bid price, no distinction will be made for the various types of curb and gutter.

#### 302.2(d) Joints.

Full contraction joints shall be a minimum of three (3) inches in depth, and shall be uniformly spaced not less than six (6) feet nor more than fifteen (15) feet apart unless otherwise directed by the Engineer.

If machine methods are used for forming and finishing curb and gutter the Contractor may saw contraction joints or planes of weakness may be created by the insertion of approved partial depth separator plates having a minimum depth of three (3) inches. The depth of cut and equipment used in sawing shall meet the approval of the Engineer. The sawing shall be done as soon as practicable after the concrete has set sufficiently to preclude raveling during the sawing and before any shrinkage cracking takes place in the concrete. If this method results in random cracking the Contractor shall be required to use the partial depth separator plates.

Transverse expansion joints shall be one-half (1/2) inch in width and shall be placed across the curb and gutter perpendicular to the curb line at all radius points of curves having a radius of two hundred (200) feet or less, and on both sides of all inlets installed in curb and gutter. All expansion joints shall extend through the entire thickness of the curb and gutter and shall be perpendicular to the surface. All expansion joints shall be formed by inserting during construction, and leaving in place, the required thickness of joint filler which shall extend through the entire thickness of both curb and gutter.

Where curb and gutter and concrete sidewalk or concrete driveways join, an expansion joint one (1) inch in width must be constructed between walks and curb.

The joint filler in transverse joints shall be flush with the finished surface of the gutter. The concrete adjacent to these joints shall be finished with a wooden float which is divided through the center and which will permit finishing on both sides of the filler at the same time. Before the curb and gutter is opened to traffic, excess joint filler shall be cut off level with the finished surface.

**302.2(e) Reinforcement.**

Where reinforcement is required it shall conform to and be placed in accordance with the Standard Detail Drawings, details shown on the plans, as specified in the contract, or as directed by the Engineer.

Where directed by the Engineer, the Contractor shall install three (3) one-half (1/2) inch round reinforcing rods fifteen (15) feet long in concrete curbs and gutters which span ditches.

**302.2(f) Protection.**

The curb and gutter must be protected from injury by traffic or other causes, and also from the rays of the sun until completely set.

In the event that concrete sidewalk, drives or curb and gutter are placed in cold weather, "Cold Weather Protection" shall be applied in accordance with The City of Madison Standard Specifications, Section 301.8(a) "Cold Weather Protection."

**302.2(g) Hand Formed Curb and Gutter (Tree Locations - Undisturbed).**

The work under this item shall consist of manually forming and pouring curb and gutter at tree locations or where other structures prevent the use of a curb machine, as designated by the Engineer.

Where the item Hand Formed Curb and Gutter is to be used in the vicinity of any tree located in the terrace, work shall be completed in accordance with section 107.13 Tree Protection Specification.

**302.2(h) Special Waterway.**

The work under this item shall consist of constructing Special Waterway in accordance with Standard Detail Drawing 3.01 and appropriate sections of the Standard Provisions.

**302.2(i) Traffic Circle Mountable Concrete Curb & Gutter.**

The work under this item shall consist of constructing Traffic Circle Mountable Concrete Curb & Gutter in accordance with Standard Detail Drawing 3.06 and appropriate sections of the Standard Provisions.

**302.3 Measurement and Payment.**

**302.3(a) Method of Measurement.**

Curb and Gutter, completed in accordance with the terms of the contract, will be measured by length in linear feet, along the flow line of the gutter and such measurement shall be continuous along such line extended across driveways, crosswalks, sidewalk ramps, and inlets.

Where a transition is made from one type of curb and gutter to another type of curb and gutter, the transition length shall be divided equally between the two types of curb and gutter.

Reinforcing steel for concrete curb and gutter installed in accordance with the terms of the contract will be measured by length in linear feet.

Cold weather protection for curb and gutter shall be measured by the lineal foot of curb and gutter, measured along the face of curb.

Special Waterway shall be measured by the square foot for completed and accepted work as shown in the SDD 3.01.

Traffic Circle Mountable Concrete Curb & Gutter shall be measured by the lineal foot for completed and accepted work as shown in the SDD 3.06.

### 302.3(b) Basis of Payment.

The footage, measured as provided above, shall be paid for at the contract unit price per linear foot, which price shall be full compensation for all preparation of subgrade and all special construction required at driveways, crosswalks, sidewalk ramps and special waterways; for furnishing all materials, including concrete masonry and expansion joints; for placing, finishing, protecting and curing; and for all labor, tools, equipment and incidentals necessary to complete the work including disposal of surplus material from excavation and restoring the site of the work.

Installing reinforcing steel, including tie bars, for concrete curb and gutter shall include furnishing the specified materials and all labor, tools, equipment and incidentals necessary to complete the work and shall be included in the unit price bid for concrete curb and gutter.

Where directed by the Engineer, the Contractor shall construct combination curb and gutter, or curbing which varies in cross section from Madison Standard curb and gutter. Unless listed as a bid item in the proposal, for such construction, the Contractor shall be paid a unit price per linear foot that has the same proportion to the unit price bid per linear foot of Madison Standard curb and gutter as the cross section area of the irregular curb and gutter has to the cross sectional area of the Madison Standard curb and gutter. The cross sectional area of the Madison Standard curb and gutter shall be considered as two (2) square feet.

The cost of reinstalling all pipe drains connected to the curbing shall be included in the unit price bid per foot of curb and gutter.

The price paid to the Contractor at driveways, crosswalks and sidewalk ramps shall be the same for regular curb and gutter, except where commercial curb cuts are specified. Commercial curb cuts shall be paid at the unit price bid for commercial curb cuts.

Cold weather protection of curb and gutter shall be paid for at the contract unit price per linear foot, measured as specified above in Method of Measurement, which price shall be full compensation for furnishing all materials; for placing and maintaining; and for all labor, tools, equipment and incidentals necessary to complete the work during the concrete curing time specified in Section 301.8 (a.) "Cold Weather Protection."

Special Waterway, measured as provided above, shall be paid for at the contract unit price which shall be full compensation for all work, materials, labor and incidentals required to complete the work as set forth in the description and SDD 3.01.

Traffic Circle Mountable Concrete Curb & Gutter, measured as provided above, shall be paid for at the contract unit price which shall be full compensation for all work, materials, labor and incidentals required to complete the work as set forth in the description and SDD 3.06.

302.3(c) Damage to Inlets.

Any damage to cast-iron inlets during construction occasioned by the Contractor shall be charged to the Contractor.

Any existing cast-iron inlet found to be defective shall be hauled to the Engineering Division Service Building storage yard at 1602 Emil Street and a new inlet will be furnished by the Contractor and shall be paid for by the City to the Contractor upon the presentation of a receipted bill.

## **ARTICLE 303 - CONCRETE SIDEWALKS, CONCRETE DRIVEWAYS, CONCRETE MOUNTABLE MEDIAN ISLAND NOSE AND STEPS OF CONCRETE MASONRY**

---

### **303.1 General.**

#### 303.1(a) Description.

This work shall consist of constructing sidewalks, sidewalk ramps, driveways, mountable median island nose, and steps of concrete masonry, with or without reinforcement placed on the prepared foundation or base and as shown on the plans and provided by the contract.

Where integral curb and sidewalk is specified, such work shall consist of a sidewalk constructed with a concrete curb built integral with the same, all in accordance with the design and details shown on the plans.

The following specifications pertain equally to concrete sidewalks, concrete sidewalk ramps, concrete driveways, concrete mountable median island nose, and concrete steps, whether the particular item of construction is mentioned or not.

All work done in the vicinity of any tree located in the terrace shall be completed in accordance with section 107.13 Tree Protection Specification.

#### 303.1(b) Sidewalk Classification Definitions subject to 10.28 MGO Allowing Designation Of Type On Subdivision Plat, Certified Survey Map Or Separate Recorded Instrument.

All private development site plans submitted for review and approval by the City of Madison shall note and identify the appropriate sidewalk classification Types I, II, III & IV on said plans. All other sidewalks contained within the site plans which are not identified shall be considered Type V.

With these policy definitions, city agencies collectively review proposed development plans and the determination shall be made as to which sidewalk classification the proposed plan best fits allowing the proper process:

- Type I      **STANDARD PUBLIC SIDEWALK – PUBLIC STREET**
- Sidewalk and underlying land publicly accepted, and owned
  - Located within fee title public right-of-way or roadway easement
  - Generally located adjacent to a street
  - Abutting property owner clears snow and ice per 10.28 MGO
  - City Engineering routinely inspects for necessary repairs/replacement
  - Repair/replacement costs shared 50%/50% between city and abutting property owner
  - City liability
- Type II      **STANDARD PUBLIC SIDEWALK – DOUBLE PUBLIC STREET FRONTAGE**
- Sidewalk and underlying land publicly accepted, and owned
  - Located within fee title public right-of-way or roadway easement
  - Generally located adjacent to a major street such as a collector or arterial street with restricted or no access
  - City clears snow and ice on the street to which the abutting property owner does not have direct access typically rear yard (Sidewalks along side yards not included in this classification)
  - City Engineering routinely inspects for necessary repairs/replacement
  - Repair/replacement costs 100% City
  - City liability
- Type III     **STANDARD PUBLIC SIDEWALK – INNER BLOCK WITHIN FEE TITLE PUBLIC RIGHT-OF-WAY OR PUBLIC EASEMENT**
- Sidewalk publicly accepted and owned
  - Located within fee title public right-of-way or public easement
  - Generally located between parcels where long blocks would otherwise burden pedestrians by requiring considerable misdirection to get to a specific destination
  - City of Madison clears snow and ice
  - City Engineering routinely inspects for necessary repairs/replacement
  - Repair/replacement costs 100% City
  - City liability
- Type IV     **STANDARD PUBLIC SIDEWALK – INNER BLOCK WITHIN PUBLIC EASEMENT**
- Sidewalk publicly accepted and owned
  - Located within public easement
  - Generally located within recorded PUD, Condominium, or apartment complex
  - Abutting or underlying property owner clears snow and ice per 10.28 MGO
  - City Engineering routinely inspects for necessary repairs / replacement
  - Repair/replacement costs shared 50%/50% between city and abutting property owner
  - City liability

Type V STANDARD OR NON-STANDARD PRIVATE SIDEWALK EXCLUSIVELY ON PRIVATE PROPERTY WITHOUT RECORDED PUBLIC EASEMENT

- Sidewalk privately owned and privately built
- Located exclusively on private property without public easement
- The construction of the private walk may be a condition of approval of the development
- Abutting or underlying property owner clears snow and ice
- The City does not inspect for necessary repairs/replacement
- Repair/replacement costs 100% property owner cost
- Exclusive Private liability



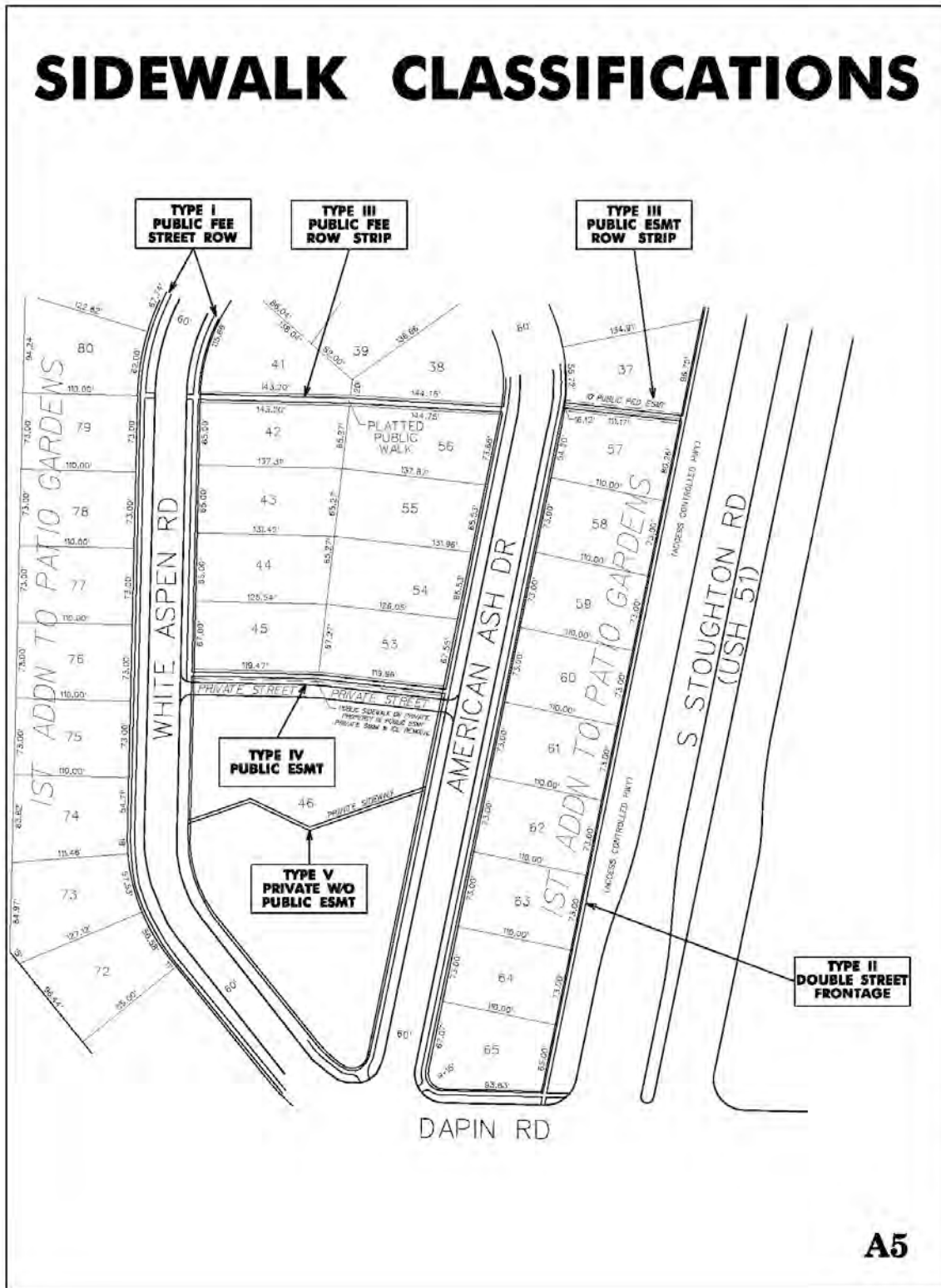

Figure 1

### **303.2 Construction Methods.**

#### **303.2(a) Preparation of Foundation.**

The foundation shall be formed by excavating or filling to the required elevation of the bottom of the concrete. The foundation so constructed shall be thoroughly mechanically compacted to insure stability. The Contractor shall undercut a minimum of two (2) inches below subgrade and backfill with two (2) inches of compacted sand, screenings (limestone or sand) or crushed aggregate base course. Three (3) inches of compacted crushed aggregate base course shall be placed under sidewalk when the centerline grade of the street exceeds 5%. Driveway aprons and curb ramps shall have six (6") of compacted crushed aggregate base course. The cost of excavating and compacted select backfill shall be incidental to the item of sidewalk construction.

The Contractor shall be responsible for replacement with approved materials, mechanically compacted, of any material necessary to bring the subbase to grade, where the Contractor has undercut the subbase without the direction of the Engineer.

Where tree roots are found to be in the same location of new sidewalk or sidewalk that is to be removed and replaced, the roots shall be removed in accordance with section 107.13 Tree Protection Specification.

#### **303.2(b) Forms.**

Sidewalk forms shall be of steel construction and have a vertical height of at least five (5) inches. Wooden forms may be used only with the Engineer's approval on short radius curves and in special cases where accessibility is limited.

All forms shall be free of hardened concrete, mud, dirt, and debris, and shall be free of bends and twists which would make their use unacceptable on the project.

All forms shall be oiled, to the satisfaction of the Engineer, before depositing or placing concrete in them.

When concrete sidewalk is constructed on a curve, flexible forms shall be used for all curves having a radius of two hundred (200) linear feet or less.

#### **303.2(c) Placing and Finishing Concrete.**

The foundation and forms, and reinforcement when required, shall be checked and approved by the Engineer before the concrete is placed.

The sidewalk shall then be given a brush or corrugated finish as the Engineer directs. Sidewalk ramps shall be given surface texturing as shown on Standard Plate for Madison Standard Sidewalk Ramps as the Engineer directs.

The Contractor shall install a header at the end of each pour. At no time shall the Contractor be allowed to spread excess concrete as a base for the next or any succeeding pour. Minimum length blocks of four (4) feet six (6) inches may be poured only at the end of a day's pour and then only with permission of the Engineer.

303.2(d) Joints.

Unless otherwise directed by the Engineer, the sidewalk shall be cut into blocks five (5) feet in length.

Transverse joints shall be constructed at right angles to the center line of the sidewalk, and longitudinal joints shall be constructed parallel to the center line of the walk, unless otherwise provided. The joints shall be constructed as laid out in the field by the Engineer. Whenever the entire area between the back of the curb and the right-of-way or lot line is to be covered with concrete sidewalk and when a permanent structure is located within such area or on the right-of-way or lot line, such sidewalk shall be constructed in alternate sections extending from the back of the curb to the permanent structure, and such sections shall not exceed twelve (12) linear feet of sidewalk length. When the alternate sections placed in the first operation have been cured as specified, the intervening sections shall be placed to complete the walk.

When the sidewalk is constructed in partial width slabs, transverse joints in adjacent slabs shall be placed in line with like joints in the previously constructed slabs. In the case of widening existing sidewalks, transverse joints shall be placed in line with like joints in the existing sidewalk.

Insofar as feasible large sidewalk slabs shall be divided into sections not less than five (5) feet nor more than twelve (12) feet in any dimension. The unit areas shall be produced by use of metal slab division forms extending to the full depth of the concrete, or, when so approved by the Engineer, by contraction joints, as defined hereinafter.

Whenever the concrete walk abuts on or is adjacent to buildings, walls, ramps, steps, castings, sidewalks, or other structures, one-half (1/2) inch expansion joint filler shall be placed. Whenever the walk abuts on or is adjacent to the curb, one (1) inch expansion joint filler shall be placed between the curb and the sidewalk. Sidewalk ramps and driveways shall have one-half (1/2) inch expansion joint filler installed between the sidewalk ramp or driveway and the City sidewalk, and one (1) inch expansion joint filler installed between the sidewalk ramp or driveway and the curb. At intervals at approximately fifty (50) feet on continuous sidewalk construction and at the ends of all radii, one-half (1/2) inch expansion joint filler shall be placed. Where the sidewalk extends from buildings to curbs, expansion joints shall be located not more than thirty (30) feet apart.

Joints shall not be sealed, unless otherwise specified.

Where the concrete walk abuts the buildings, walls, other pavement or as directed by the engineer in placing exposed aggregate sidewalk the material shall be left 1/2" below the surface and shall extend to the bottom of the concrete. A removable plastic strip, flush with the surface of the concrete, shall be placed over the foam or sponge rubber material while the concrete is being poured and cured.

The Contractor shall place a troweled joint at standard back edge of sidewalk where sidewalk extends to meet buildings.

Expansion joint material shall be non-staining and compatible with the sealant and of resilient nature such as closed cell resilient foam or sponge rubber. Materials impregnated with oil, bitumen or similar materials shall not be used.

All joints along buildings and exposed aggregate concrete joints as directed by the engineer shall be sealed. The sealants shall be the gun grade Sonolastic NPI urethane as manufactured by Sonneborn,

or an approved equal. The color shall match the adjoining work and shall be approved by the Engineer. Primers shall be used only where the manufacturer recommends.

Modifications of a sealant by the addition of liquids or powders to alter the flow properties SHALL NOT be permitted.

A sealant SHALL NOT be used if the date of manufacture indicates that the sealant is more than twelve (12) months old. Where a lesser period is recommended by the manufacturer, the lesser period shall govern.

The Contractor shall submit the following:

1. Sealant manufacturer's instructions, including limitations for application and priming. Indicate on the brochure or by transmittal, which primers will be used or submit printed statements from the sealant manufacturer that no primers are required for maximum adhesion.
2. Sealant manufacturer's standard color range for selection. Color shall be selected by the Engineer.

All joint surfaces shall be dry and thoroughly clean. The Contractor shall remove all loose particles, dirt, paint, foreign matter, or curing compound by means not injurious to the materials to be sealed.

Concrete shall be cured (seven (7) days minimum) and dry before sealant application.

Unless otherwise specified herein, preparation of the surfaces, mixing and application of the sealants shall be in accordance with the written instructions of the sealant manufacturer and /or subsequent supplementary written recommendations of the manufacturer or Engineer.

No sealant shall be applied to a joint at temperatures under 40°F.

All joints shall be finished to assure proper filling of voids, elimination of air pockets and maximum contact at joint interfaces. Immediately upon completion of the joint sealing, a silica sand shall be placed over the joint material. Any sealed joint not completely filled and/or not properly finished shall be reopened and replaced as directed by the Engineer.

At the completion of the caulking work, the surface of materials adjoining such work shall be cleaned of all smears, excess compound or other dirt and left in a neat, satisfactory condition. Rough unsightly work shall not be accepted.

Sealants and expansion joints shall be incidental to installation of concrete sidewalk, driveways and integral sidewalk curb head.

No additional compensation shall be given at these locations.

### 303.2(e) Reinforcement.

Where reinforcement is required, it shall conform to and be placed in accordance with the details shown on the plans, as specified in the contract, or as directed by the Engineer.

The Contractor shall install three (3), one-half (1/2) inch round reinforcing rods fifteen (15) feet long in concrete sidewalks which span ditches.

**303.2(f) Protection.**

The sidewalk must be protected from injury by traffic or other causes, and also from the rays of the sun until completely set. Sidewalks may be opened to pedestrian traffic after expiration of the curing period.

In the event that concrete sidewalk, drives or curb and gutter are placed in cold weather, "Cold Weather Protection" shall be applied in accordance with The City of Madison Standard Specifications, Section 301.8(a) "Cold Weather Protection."

**303.2(g) Replacement of Concrete Sidewalk.**

At such places and for such distances as shall be designated by the Engineer or the Sidewalk Inspector of the City, the Contractor shall replace concrete sidewalks by breaking up and removing all old material and preparing the existing foundation for the construction of the concrete sidewalk. Upon the foundation so prepared, the Contractor shall construct a concrete sidewalk in accordance with the foregoing specifications. The cost of removal of all old concrete material shall be included in the amount bid per square foot of sidewalk replacement, unless otherwise specified in the contract.

**303.2(h) Contractor's Identification.**

The Contractor shall stamp the Contractor's name and the year constructed on the concrete work which the Contractor constructs or reconstructs for the City of Madison. Such identification shall be stamped at the beginning and end of each section of the project. The stamp shall be approximately five (5) inches by seven (7) inches in size, and may be either oval or rectangular in shape.

**303.2(i) Concrete Sidewalks.**

Concrete sidewalks shall be five (5) inches in thickness, five (5) feet in width, constructed of nonreinforced concrete, with a transverse slope of 1.50%, unless otherwise noted on the plans or in the special provisions of the contract, or unless otherwise directed by the Engineer.

Where directed by the Engineer, all existing sidewalk in the terrace between the curb and public sidewalk that is removed during the construction of new curb and gutter, shall be replaced in the same location and to the same dimensions as was true of original terrace walks.

**303.2(j) Concrete Aprons.**

All concrete driveways, concrete sidewalk at commercial driveways, curb ramps and where otherwise designed by the Engineer shall be seven (7) inches and constructed of nonreinforced concrete unless otherwise noted on the plans or in the Special Provisions of the contract. Expansion joints shall conform to the requirements of Subsection 303.2(d). Contraction joint shall conform to the requirements of Subsection 303.2(d), except that the Contractor may cut diagonal joints in order to control the cracking of the concrete in the curved areas of commercial drives.

303.2(k) Concrete Mountable Median Island Nose.

Mountable median island nose shall be constructed at the locations and in accordance with the design, dimensions and details shown on the plans.

303.2(l) Steps of Concrete Masonry.

When construction of steps is included in the contract, they shall be built at the locations and in accordance with the design, dimensions and details shown on the plans. The work shall include reinforcement and necessary excavation, backfilling, and disposal of excess material from excavation.

303.2(m) Profile Sawcuts.

Where directed by the Engineer, the Contractor shall construct curb cuts in existing curb and gutter, using a "profile curb cut" with the curb head removed by using a machine type concrete saw specifically designed for this type of work.

303.2(n) Curb Ramp Detectable Warning Field.

Description

This special provision describes placing detectable warning fields in curb ramps in accordance with the requirements of the standard specifications and as hereinafter provided.

Materials

Furnish Curb Ramp Detectable Warning Fields, which shall be cast iron set in the concrete, manufactured by East Jordan Ironworks, Neenah Foundry, Pioneer Detectable LLC (or equivalent).

Construction

Place curb ramp detectable warning field as shown and detailed in the standard specifications, detail 3.03 and 3.04.

303.2(o)

- Tree Grate 4' x 6' (Including Frame)
- Tree Grate 4' X 8' (Including Frame)
- Tree Grate 5' X 5' (Including Frame)
- Tree Grate 4' X 12' (Including Frame)
- Tree Grate 5' Diameter Circle (Including Frame)

Description

This work shall consist of the furnishing and installing tree grates as shown on the plans and as herein provided.

### Materials

Tree grates shall be cast iron per ASTM A48 class 35b or better. Standard finish is raw cast grey iron. Tree grate shall be ADA compliant, provide with angle frame and rebar. Casting shall be:

R-8811 (4' x 6' rectangle)

R-8815-A (4' by 8' rectangle)

R-8815 (4' x 12' rectangle)

R-8713 (5' x 5' square)

R-8871 (5' Diameter Circle)

Approved product shall be from Neenah Foundry Co. P.O. Box 729, 2121 Brooks Ave. Neenah, WI 54957, 920-725-7000, or Approved equal.

### Construction

The location of each grate shall be marked on the pavement or curb by the City Forester.

Install tree grates according to manufacturer's instructions and as shown on the details to provide installation on a true, flat plane.

Concrete installation under the grate frame shall be formed or cut back flush with the inside edge of the grate frame.

The Contractor shall excavate a minimum of three feet in depth in the location of the proposed tree grate to ensure location is suitable for tree planting. Any obstructions shall be reviewed by City Forestry for tree suitability and possible tree grate location adjustment.

The Contractor shall fill/plug the center tree hole of all grates that do not have trees in areas that are open to pedestrians as a result of the tree plantings not occurring until November. The surface shall be level with the surface of the tree grate. Tree hole shall be filled/plugged with a piece of plywood wired to the grate. A traffic cone shall be screwed to the top of the plywood. The Contractor shall support the center of the tree grate for those that do not have trees to prevent them from being broken. Unsupported grates broken before tree planting occurs (up to one calendar year if tree planting is by others) shall be the responsibility of the Contractor to replace.

### **303.3 Measurement and Payment.**

#### 303.3(a) Method of Measurement.

Sidewalks, sidewalk ramps, mountable median island nose, driveways and steps shall be measured by area in square feet. The measured areas of crosswalks shall be included with the measured areas of sidewalks.

Curb Ramp Detectable Warning Field shall be measured in place by the square feet of surface area.

Tree grates as described above shall be measured by the unit, each, installed and accepted in place. All tree location test holes shall be considered incidental to the tree grate.

When required, the "Profile Sawcut" shall be measured by length in linear along the flow line of the curb.

In the case of integral curb and walk, the width of the walk shall extend to a point six (6) inches behind the face of curb. The curb shall be paid for separately as Curb and Gutter.

In the case of steps, the area measured for payment shall be the summation of the areas of the treads, computed by multiplying the width of the tread by the length of the tread out to out of integral wall, if any.

Reinforcing steel for concrete sidewalk installed in accordance with the terms of the contract will be measured by length in linear feet.

Cold weather protection for sidewalk and drives shall be measured by the square foot of sidewalk or driveway surface.

### 303.3(b) Basis of Payment.

The area, measured as provided above, shall be paid for at the contract unit price per square foot for the items of concrete sidewalk, concrete driveways, concrete mountable median island nose, and concrete steps, which price shall be full compensation for furnishing all materials, including concrete masonry, expansion joints and sealant; for excavations and preparation of subgrade including subbase, backfilling, and disposal of surplus material; for forming; for placing, finishing, protecting, jointing, sealing and curing of the concrete; and for all labor, tools, equipment and incidentals necessary to complete the work and restore the site of the work. Providing and placing crushed aggregate base course shall be paid for separately with bid item 40102.

Payment for Curb Ramp Detectable Warning Field is full compensation for providing all materials, including detectable warning field panels, finishing, protecting, and curing concrete; and restoring the work site; and for all labor, tools, equipment and incidentals required to complete the work and restore the site. Payment for any concrete sidewalk directly below detectable warning field is paid for separately under the applicable concrete sidewalk bid item.

Payment for Tree Grate as described above, measured as provided above, will be paid for at the contract unit price each, which price shall be payment in full for furnishing, installing tree grates and washed stone; and for furnishing all labor, tools, equipment and incidentals necessary to complete this item of work.

The footage for profile sawcut, measured as provided above, shall be paid for at the contract unit price per linear foot, which price shall be full compensation for excavating; for all labor, tools, materials, and equipment necessary to complete the work, including crushed stone made necessary by excessive excavation behind the curb; and for disposal of the concrete.

The contract price for reinforcing steel for concrete sidewalk shall include furnishing the specified materials and all labor, tools, equipment and incidentals necessary to complete the work.

Cold weather protection for sidewalk and drives shall be paid for at the contract unit price per square foot, measured as specified above in Method of Measurement, which price shall be full compensation for furnishing all materials; for placing and maintaining; and for all labor, tools, equipment and incidentals necessary to complete the work during the concrete curing time specified in Section 301.8(a.) "Cold Weather Protection."



### Part III - Concrete and Concrete Structures

Where reinforcing steel for concrete sidewalk is not listed as an item on which to submit unit prices, it shall be understood and agreed that the Contractor shall be paid seventy-five (\$0.75) cents per linear foot of uncoated reinforcing steel, and one (\$1.00) dollar per linear foot of epoxy-coated reinforcing steel furnished and placed in accordance with these Specifications.

## **ARTICLE 304 - MISCELLANEOUS CONCRETE STRUCTURES**

---

### **304.1 General.**

#### 304.1(a) Description.

This work shall consist of constructing miscellaneous concrete structures, including survey monuments, walls, footings, cunettes, apron slabs on culverts, ditch checks, headwalls, access structures, catchbasins, and box culverts, with or without reinforcement, of the required design and dimensions, placed on the prepared foundation or base, all as shown on the plans and provided by the contract.

All work done in the vicinity of any tree located in the terrace shall be completed in accordance with section 107.13 Tree Protection Specification.

#### 304.1(b) Concrete Requirements.

All requirements under Article 301 - Concrete, for mix design, High-Early-Strength Concrete, tests, materials, mixing, placing, forms, curing, and protection of the concrete shall apply to concrete used in the construction of miscellaneous concrete structures.

#### 304.1(c) Equipment.

Equipment and tools necessary for performing all parts of the work shall be satisfactory as to design, capacity and mechanical condition for the purposes intended, and any equipment which is not maintained in full working order, or which as used by the Contractor is inadequate to obtain the results prescribed, shall be repaired, improved, replaced or supplemented to obtain the progress and quality of work contemplated by the contract.

### **304.2 Construction Methods.**

#### 304.2(a) Preparation of the Foundation.

The foundation shall be formed by excavating or filling to the required elevation of the bottom of the compacted select fill lift. The foundation so constructed shall be thoroughly mechanically compacted to insure stability.

The foundation shall be made sufficiently wide to permit placing of forms and performing the required work of placing the concrete and finishing.

The Contractor shall be responsible for replacement with 1-1/2" crushed stone, mechanically compacted, of any material necessary to bring the subbase to grade where the Contractor has undercut the subbase without approval of the Engineer. Where expressly ordered by the Engineer, the Contractor shall additionally excavate where unsuitable foundation material exists. When this condition arises, the excavation shall be carried to such depth as directed by the Engineer. Cross sections of this additional excavation will be taken to determine the amount of material removed. The maximum width shall be the outside dimension of the structure plus two (2) feet. Mechanically compacted 1-1/2" crushed stone shall be installed to subbase grade. All costs for additional excavation, including excavation, crushed stone, and disposal of excavation, shall be included in the unit price bid for "Extra Trench Excavation".

304.2(b) Installation of Select Fill Lift.

The Contractor shall install a select fill lift from the foundation to the bottom of the structure of the depth shown on the plans or specified in the contract.

Except as provided by plans and specifications, the select fill lift shall consist of mechanically compacted 1-1/2" crushed stone extending one (1) foot beyond the structure on each side.

The cost of the select fill lift shall be included in the unit price bid for the respective structure.

When the local water conditions are such that the required select fill lift impedes construction, the Contractor may use an alternate material with the approval of the Engineer. The Contractor shall submit a price for the alternate material.

304.2(c) Placing and Finishing Concrete.

The foundation and forms, and reinforcement when required, shall be checked and approved by the Engineer before the concrete is placed. The concrete shall be placed on a moist foundation, deposited to the required depth and consolidated and spaded sufficiently to bring the mortar to the surface, after which it shall be struck off and floated with a wooden float. Before the mortar has set, the surface shall be steel troweled until a smooth surface is obtained.

The Contractor may, with prior approval of the Engineer, elect to use a machine for placing, forming and consolidating of the concrete. If a machine is used, the resulting structure shall be of such quality as to equal or exceed that produced by methods herein before described.

Unless otherwise provided, the edge of the structure along forms and edges adjacent to expansion or contraction joints shall be finished with a steel edging tool of one-fourth (1/4) inch radius.

The Contractor shall furnish an accurate straight edge ten (10) feet long to test the surface. The straight edge shall be advanced along the center of the flowline no more than one-half (1/2) of its length when the concrete is still plastic. Any depressions found shall be immediately filled with freshly mixed concrete, struck off, consolidated, and refinished. Projections shall be struck off and refinished. The straight edging shall be continued until the center of the flowline is free from any deviations and irregularities.

304.2(d) Reinforcement.

Where reinforcement is required, it shall conform to and be placed in accordance with the details shown on the plans, as specified in the contract, or as directed by the Engineer.

The reinforcement shall be placed at the proper depth and properly secured so that it will remain in place while the concrete is placed.

304.2(e) Joints.

Transverse joints shall be constructed at right angles to the center line of the structure, and longitudinal joints shall be constructed parallel to the center line, unless otherwise provided.

A contraction joint shall consist of a slot or groove at least two (2) inches deep and one-fourth (1/4) inch wide formed by inserting a metal parting strip or jointing tool in the concrete after it has been struck off and consolidated and while the concrete is still plastic. As soon as the concrete will retain its shape, the parting strip shall be removed and the joint edge finished.

Unless otherwise specified, transverse contraction joints shall be on twenty (20) foot centers.

An expansion joint shall consist of one (1) inch of expansion joint filler of the same shape and dimensions as the section.

Unless otherwise specified, transverse expansion joints shall be placed on two hundred (200) foot centers.

### **304.3 Measurement and Payment.**

#### **304.3(a) Method of Measurement.**

Headwalls shall be measured as units. Cunettes, apron slabs on culverts, ditch checks and box culverts shall be measured by length in linear feet along the center line of the structure, exclusive of catchbasins.

Preparation of foundation shall be measured as Excavation Cut, or Fill as specified in Articles 201 and 202, Part 2 - Earthwork. The limit of Excavation Cut or Fill shall be the bottom of the select fill lift as shown on the plans or as specified in the contract.

#### **304.3(b) Basis of Payment.**

Headwalls shall be paid for at the contract unit price per unit, which price shall be full compensation for furnishing all materials, including concrete masonry and expansion joints; for excavations and preparation of subgrade including subbase, backfilling, and disposal of surplus material; for forming; for placing, finishing, protecting and curing of the concrete; and for all labor, tools, equipment and incidentals necessary to complete the work and restore the site of the work.

The lengths of cunettes, apron slabs on culverts, ditch checks and box culverts, as provided above, shall be paid for at the contract unit price per linear foot of Concrete Cunette, Concrete Apron Slabs on Culverts, Concrete Ditch Checks and Concrete Box Culvert, which price shall be full compensation for furnishing all materials, including concrete masonry, reinforcement and expansion joint filler, for furnishing and installing the required select fill lift; for forming; for placing, finishing, protecting and curing of the concrete; and for all labor, tools, equipment and incidentals necessary to complete the work.

The volumes of Excavation Cut or Fill, as provided above shall be paid for at the contract unit price per cubic yard for Excavation Cut or Fill, which price shall be full compensation for all excavation and disposal of material specified to be excavated, for furnishing, hauling, placing and compacting the specified material in fills, for backfilling and disposal of surplus materials, for restoring the site of the work, and for all equipment, tools, labor and incidentals necessary to complete the work as specified.

## **ARTICLE 305 - SIDEWALK REPLACEMENT PROGRAM**

---

### **305.1 General.**

The following specifications cover the work involved in the sidewalk replacement program of various sidewalks. The program includes: contract(s) to replace sidewalk curb & gutter and pavement ordered, requested and sawcut offsets.

The proposed listing of streets and sidewalks and proposed quantities of work listed in the contract shall be subject to additions or deletions by the Engineer. The Engineer shall give written notice to the Contractor of any such additions or deletions.

The Contractor shall not be entitled to additional compensation in the event quantities are added or deleted unless by mutual agreement by both the Contractor and the City.

If the quantities of any item is reduced, such decrease **SHALL NOT** constitute a claim for damages by the Contractor for loss of anticipated profits, **NOR** shall the Contractor be compensated for any overhead, equipment, material and labor charges, or any other costs incurred in the expectation of any quantity of work originally estimated in the Contract.

The various public and private utilities, including, but not limited to, sanitary sewers, storm sewers, water, gas, electric, telephone, traffic signals, street lighting, and cable television, may have facilities within the limits of the sidewalks to be replaced which will require repairs or alterations. The Contractor shall so schedule his work that those utilities which have to make repairs or alterations to their facilities will not cause the final completion date of all work included with the contract to extend beyond the specified time of completion.

The Contractor shall notify the Engineer daily of all work to be performed. If the Contractor performs work without notification of the Engineer said work and materials shall be at no cost to the City. The Contractor shall designate one person on each work crew, including subcontractors, to supervise the work crew and to be responsible to the Engineer for traffic control settings, marking and measuring work, acquisition of construction materials, systematic scheduling, etc. The said designated person shall be familiar with the work and may be a member of the work crew.

All traffic signing and barricading shall conform to the Federal Highways Administrations "Manual on Uniform Traffic Control Devices" (MUTCD) and City of Madison Supplements for sidewalk and bikeway closures and the State of Wisconsin Standard Detail Drawing S.D.D. **15d 30-1**.

On street parking may be removed by the contractor to facilitate construction, resurfacing and maintain traffic flow. The contractor shall notify the traffic Engineering Division, forty-eight (48) hours in advance of proposed parking removal. The contractor shall obtain from the City and place "No Parking" portables, "No Parking" cardboard signs or meter bags whichever is applicable for the particular street. "No Parking" restrictions must be placed a minimum of 48 hours in advance of the beginning of construction. On streets where Zone Parking, (2-hour) is in effect or signed loading zones in effect, the contractor shall cover these signs with black plastic bags when No Parking portables or signs are placed in the same area.

On streets where there is not time restriction on parking, the Contractor shall post said streets at least forty-eight (48) hours prior to beginning work with "No Parking" signs legibly marked with the date and time of restricted parking. The Contractor shall notify the Police Department Traffic Bureau at

266-4622 during regular hours or the Police Dispatcher after regular hours stating the construction company name, the contract number, the street or streets posted, the time and date posted, and shall request that Police Department Personnel check the posting.

On all streets where there is a time restriction on parking, the Contractor shall post said street at least twelve hours prior to beginning work with “No Parking” signs legibly marked with the date and time of restricted parking. The Contractor shall notify the Police Department Traffic Bureau the same as above.

On streets where residential permit parking is allowed, the Contractor shall post said street at least forty-eight (48) hours prior to beginning work with “No Parking” signs legibly marked with the date and time of restricted parking. Residential permit parking zones are indicated with a zone number located in the lower corner of the permanent time restriction sign. The Contractor shall notify the Police Department Traffic Bureau the same as above.

The Contractor shall post “no parking” signs at the beginning, midpoint, and the end of each block plus additional signs as needed. “No parking” signs shall be posted a minimum of three (3) feet above curb elevations. If no work is begun on the posted street within two (2) days of the posted start date, the Contractor shall remove the “no parking” signs and repost the street when ready to begin work on that street.

The Contractor shall be responsible for erecting, re-erecting, maintaining, and removing those “No Parking” controls devices stated above.

The Contractor shall maintain two-way traffic on all two-way streets.

The Contractor shall observe peak hour traffic restrictions on certain streets between the hours of 7:00 A.M. to 8:30 A.M. and 4:00 P.M. to 5:30 P.M. Peak hour traffic restrictions apply to all signalized intersections and arterial streets. During these hours, no work shall be performed in or adjacent to the roadway where traffic is being maintained or deliveries being made to the site that will in any way interfere with the movement of traffic. The list of streets with peak hours restrictions shall be listed in the Special Provisions. Exceptions to this time restriction require approval of the Engineer.

The Contractor shall furnish, install and maintain all provisions for traffic control as specified in Article 107 of these specifications. The Contractor shall also furnish, install and maintain additional traffic control devices as specified in the special provisions of the contract or as directed by the Engineer in order to control and divert traffic to the proper travel lanes of the street being worked on.

Electric lighting (Type A flashers) shall be used for lighting of all work areas. Type II barricades shall be used for all work in the street, sidewalk, drive apron, and curb and gutter areas.

All cost pertaining to the above Traffic Control work shall be **incidental**.

All work done in the vicinity of any tree located in the terrace shall be completed in accordance with section 107.13 Tree Protection Specification.

**305.2 Remove & Replace 5 Inch Concrete Sidewalk-Sidewalk Replacement Program;  
Remove & Replace 7 Inch Concrete Sidewalk & Drive-Sidewalk Replacement Program.**

305.2(a) Description.

Concrete walk and drive apron shall consist of removing and replacing existing concrete walk and drive apron where designated by the Engineer in accordance with section 303.3 of The City of Madison Standard Specifications except as modified herein.

Removal and replacement of sidewalk and drive aprons shall include all costs for excavating, replacement of disturbed sub-base material with four (4") of 3/4" crushed stone or crushed concrete, grade preparation, tree root removal, expansion joints and disposal. Tree root removal shall be completed in accordance with section 107.13 Tree Protection Specification.

Removal of sidewalks and drive aprons shall include excavation of existing material including asphalt material, up to one (1) foot on each side of the sidewalk or drive aprons, as the case may be, except all work done in the vicinity of any tree located in the terrace shall be completed in accordance with section 107.13 Tree Protection Specification. All material shall be hauled from the site. At no time shall any material be deposited on private property or terrace areas.

Existing concrete, asphalt mixes or other types of material used to shim raised sidewalks shall be removed from adjacent sidewalk stones prior to placing new sidewalk.

After the new sidewalks have been constructed and the forms removed, the excavated areas adjacent to the sidewalk shall be back filled immediately with the appropriate material; topsoil, crushed stone, concrete or asphalt mix.

The cost of placing and compacting select backfill shall be incidental to this item.

Transverse full depth sawcuts shall be incidental to the removal item.

All debris shall be removed from the excavated areas prior to placement of the topsoil.

The Contractor shall take precautions during construction operations not to disfigure, scar, or impair the health of any tree on public or private property.

The Contractor shall remove tree roots from existing live trees in accordance with section 107.13 Tree Protection Specification.

Tree roots ends one-half inch (1/2") and up which are severed shall be cut in accordance with section 107.13 Tree Protection Specification. The tree root ends shall be back filled with soil or other suitable means immediately following the cutting.

Sidewalk and driveway aprons in residential areas shall be replaced within three (3) work days after it has been made impassable or removed. Sidewalk, driveways, and drive aprons adjoining multi-family units and business properties shall be replaced within twenty-four (24) hours after being made impassable or removed.

305.2(b) Method of Measurement.

Concrete sidewalk shall be measured by the Square Foot.

305.2(c) Basis of Payment.

The contract unit price shall be paid as per Section 303.3(b) of The City of Madison Standard Specifications except that the unit price shall include: removal of sidewalk or drive apron; asphalt sawcut; fill; topsoil; seed and **matting**.

**305.3 Remove & Replace Concrete Steps-Sidewalk Replacement Program.**

305.3(a) Description.

This work shall consist of removing and constructing concrete steps as directed by the Engineer.

Disturbed areas of the subbase shall be graded and prepared with 3/4" crushed stone or crushed concrete. Removal of steps shall include excavation of existing material including Asphalt material, up to one (1) foot on each side. All material shall be hauled from the site. At no time shall any material be deposited on private property or terrace areas.

305.3(b) Method of Measurement.

This bid item shall be measured by the square foot of completed and accepted work.

305.3(c) Basis of Payment.

This item, measured as provided above, will be paid for at the contract price per square foot. This price shall be full compensation for furnishing all labor, tools, materials, equipment, and incidentals necessary to complete the work.

**305.4 Remove Existing Asphalt Sidewalk & Drive-Sidewalk Replacement Program.**

305.4(a) Description.

The work under this item shall consist of sawcutting, removing and disposing of Asphalt sidewalk and driveway.

All Asphalt cutting shall be done by whatever means to achieve the desired edge at the prescribed location. The cost for said cutting shall be incidental to the removal item.

305.4(b) Method of Measurement.

This bid item shall be measured by the square foot of completed and accepted work.

305.4(c) Basis of Payment.

This item, measured as provided above, will be paid for at the contract price per square foot. This price shall be full compensation for furnishing all labor, tools, materials, equipment, and incidentals necessary to complete the work.



### **305.5 Remove & Replace Concrete Curb & Gutter-Sidewalk Replacement Program.**

#### 305.5(a) Description.

Concrete curb and gutter shall consist of removing and replacing existing concrete curb and gutter where designated by the Engineer in accordance with The City of Madison Standard Specifications **Section 302** except as modified herein.

When a portion of curb and gutter to be replaced contains an inlet, the cost of adjusting the inlet, if for the convenience of the Contractor, in its same location shall be included in the unit price bid of remove and replace concrete curb and gutter.

Removal and replacement of concrete curb and gutter shall include excavating, replacement of disturbed sub-base material with four (4") of 3/4" crushed stone or crushed concrete, grade preparation, tree root removal, expansion joints and disposal. If directed by the Engineer, "Type X" curb will be required at various locations at no additional cost. Tree root removal shall be completed in accordance with section 107.13 Tree Protection Specification.

The Contractor shall place all curb & gutter with the use of a slip form paver as directed by the Engineer or except where obstructions prevent the uses of a machine. Obstructions shall include but not be limited to: inlets; sidewalk; castings and trees.

Removal of concrete curb and gutter shall include excavation of existing material including asphalt material, up to one (1) foot on each side of the curb and gutter, as the case may be, except all work done in the vicinity of any tree located in the terrace shall be completed in accordance with section 107.13 Tree Protection Specification. All material shall be hauled from the site. At no time shall any material be deposited on private property or terrace areas.

Existing concrete, asphalt mixes or other types of material used to shim raised curb & gutter shall be removed from adjacent curb & gutter stones prior to placing new curb & gutter

After the new curb and gutter has been constructed and the forms removed, the excavated areas adjacent to the curb and gutter shall be back filled immediately with the appropriate material; topsoil, crushed stone, concrete or asphalt mix.

All debris shall be removed from the excavated areas prior to placement of the topsoil.

The cost of placing and compacting select backfill shall be incidental to this item.

Transverse full depth sawcuts shall be incidental.

The Contractor shall construct the curb cuts using a "profile curb cut" with the curb head removed by using a machine type concrete saw specifically designed for this type of work. The curb shall be cut off flush with the flow line through the ramp. Profile curb cut shall be paid under **BID ITEM 30330 – PROFILE CURB CUT.**

The Contractor shall take precautions during construction operations not to disfigure, scar, or impair the health of any tree on public or private property.

The Contractor shall remove tree roots from existing live trees in accordance with section 107.13 Tree Protection Specification.

Tree roots ends one-half inch (1/2") and up which are severed shall be cut in accordance with section 107.13 Tree Protection Specification. The tree root ends shall be back filled with soil or other suitable means immediately following the cutting.

**305.5(b) Method of Measurement.**

Concrete Curb and Gutter shall be measured by length in lineal feet in accordance with Section 302.3(a) of The City of Madison Standard Specifications.

**305.5(c) Basis of Payment.**

The contract unit price shall be paid as per Section 302.2(b) of The City of Madison Standard Specifications except that the unit price shall include removal for curb and gutter, sawcut; fill, topsoil, seed and matting.

**305.6 Reset Brick Pavers-Sidewalk Replacement Program.**

**305.6(a) Description.**

The work under this item shall consist of removing existing brick pavers, base preparation, and resetting of salvaged brick pavers to grade.

Sand shall be used to bring the subbase to the proper grade. The subbase shall be compacted. Dusting of sand shall be used to fill between the reset bricks.

The cost of placing and compacting select backfill shall be incidental to this item.

**305.6(b) Method of Measurement.**

This bid item shall be measured by the square foot.

**305.6(c) Basis of Payment.**

This item, measured as provided above, will be paid for at the contract price per square foot. This price shall be full compensation for furnishing all labor, tools, materials, equipment, and incidentals necessary to complete the work.

## **ARTICLE 306 - MISCELLANEOUS**

---

### **306.1 General.**

This article shall consist of miscellaneous work in accordance with these Specifications, the Contract, as shown on the plans and cross sections, or as directed by the Engineer. The work shall be done at the locations and to the lines and grades as shown on the plans or as directed by the Engineer.

### **306.2 Description.**

306.2(a) Horizontal saw cut concrete sidewalk, driveways, traffic islands and steps.

Existing concrete, Asphalt mixes, or other types of material used to shim raised sidewalks, shall be removed from adjacent sidewalk stones prior to horizontal saw cutting sidewalk.

The Contractor shall take precautions during construction operations not to disfigure, scar, or impair the health of any tree on public or private property. The Contractor shall also take precautions during saw cutting operations not to disfigure, scar, or impair any surrounding surfaces including but not limited to sidewalk, driveways, roadway, steps, walls and turf or damage any private installations such as sprinkler heads, electric fences, etc.

All trip hazards marked for horizontal saw cutting must be removed in accordance with the American with Disabilities Act (ADA) requirements and the resulting finish shall be ADA compliant. Each offset must be tapered at a 1:8 slope and must have smooth uniform appearance and texture. The finished surface shall have a coefficient of friction of at least 0.6.

The finished result of each horizontal saw cut shall be taken to a zero point of differential settlement along the entire length of the cut and to both edges of the sidewalk to eliminate trip hazards the full width of the sidewalk.

All horizontal saw cutting shall be done with diamond-tipped blades and saws capable of cutting at any angle and able to remove the concrete completely to all edges of the walk.

### **306.3 Method of Measurement.**

306.3(a) Horizontal sawcut concrete sidewalk, driveways, traffic islands and steps.

Inch -Feet Measurement shall be made by the average depth of cut on each trip hazard multiplied by the length along the joint that is trimmed. Exact dimensions of each trip hazard shall be recorded by the contractor. Depth shall be measured to the nearest 1/8th inch. Length of cut shall be measured to the nearest 1/4 foot.

### **306.4 Basis of Payment.**

306.4(a) Horizontal sawcut concrete sidewalk, driveways, traffic islands and steps.

This item, measured as provided above, will be paid for at the contract price per inch-feet. This price shall be full compensation for furnishing all labor, tools, materials, equipment, restoration, topsoil, seed and matting and incidentals necessary to complete the work as described above.

## Part IV - Pavements

ARTICLE 401 - CRUSHED AGGREGATE BASE COURSE .....	1
401.1    General.....	1
401.2    Construction Methods.....	2
401.3    Measurement and Payment.....	4
ARTICLE 402 - ASPHALT CONSTRUCTION.....	6
402.1    Materials for Asphalt Construction.....	6
402.2    Placing Asphalt Mixtures.....	6
402.3    Asphalt Pavement.....	9
402.4    Asphalt Tack Coat.....	10
402.5    Recycled Asphalt Pavement.....	11
402.6    Measurement and Payment.....	11
ARTICLE 403 - RESURFACING.....	13
403.1    General.....	13
403.2    Grinding.....	16
403.3    Pulverize and Shape.....	19
403.4    Undercut.....	20
403.5    Asphalt Tack Coat.....	20
403.6    Asphalt Lower Layer.....	20
403.7    Asphalt Upper Layer.....	21
403.8    Asphalt Base Patching.....	21
403.9    Asphalt Drive And Terrace - Resurfacing.....	22
403.10   HMA Material For Curb Front Fill.....	23
403.11   SAS Adjusting Ring.....	23
403.12   Adjust Access Structure Casting - Resurfacing.....	24
403.13   Adjust Catchbasin Casting - Resurfacing.....	25
403.14   Adjust Inlet Casting, Type "H" - Resurfacing.....	26
403.15   Adjust Inlet Casting, "Tub" Type - Resurfacing.....	26
403.16   Adjust Valve Casting, Method #1 - Resurfacing, Adjust Valve Casting, Method #2 - Resurfacing, Install Adjustable Water Box, Method #3 - Resurfacing.....	27
403.17   Adjust Monument Casting - Resurfacing.....	28
403.18   Adjust Private Utility Castings - Resurfacing.....	29
403.19   Rebuild Inlet - Resurfacing.....	29
403.20   Rebuild Access Structure Top - Resurfacing.....	30
403.21   Remove and Replace Concrete Curb & Gutter, Machine Placed - Resurfacing; Remove and Replace Concrete Curb & Gutter, Hand Placed - Resurfacing.....	31
403.22   Remove and Replace 5 Inch Concrete Sidewalk - Resurfacing; Remove and Replace 7 Inch Concrete Sidewalk and Drive - Resurfacing.....	32
403.23   Crushed Stone - Resurfacing.....	33
403.24   Remove Asphalt Surface - Resurfacing.....	33
403.25   Remove Concrete Utility Patch.....	33
ARTICLE 404 - CONCRETE PAVEMENT.....	35
404.1    General.....	35
404.2    Forms.....	35
404.3    Steel Pins.....	35

404.4	Concrete Speed Hump. ....	35
404.5	Concrete Pavement Reconstruction. ....	36
ARTICLE 405 - INFRARED SEAMLESS PATCHING.....		38
405.1	General.....	38
405.2	Personnel.....	38
405.3	Materials. ....	38
405.4	Equipment.....	38
405.5	Preparation and Installation. ....	38
405.6	Method of Measurement.....	39
405.7	Basis of Payment.....	39
ARTICLE 406 - PAVEMENT CRACK SEALING.....		40
406.1	Materials For Pavement Crack Sealing.....	40
406.2	Preparation of the Crack Sealing Mixtures.....	40
406.3	Installation of Crack Sealing.....	40
406.4	Method of Measurement.....	41
406.5	Basis of Payment.....	42
ARTICLE 407 - SPRAY PATCHING.....		43
407.1	General.....	43
407.2	Personnel.....	43
407.3	Equipment.....	43
407.4	Preparation and Installation of Spray Patching.....	43
407.5	Method of Measurement.....	44
407.6	Basis of Payment.....	44
ARTICLE 408 - PAVEMENT CHIP SEAL.....		45
408.1	Materials For Pavement Chip Sealing.....	45
408.2	Personnel.....	45
408.3	Equipment.....	45
408.4	Preparation of the Surface and Protection.....	46
408.5	Method of Measurement.....	46
408.6	Basis of Payment.....	47

## **ARTICLE 401 - CRUSHED AGGREGATE BASE COURSE**

---

### **401.1 General.**

#### **401.1(a) Description.**

This item shall consist of a dense compacted base course composed of two or more courses or layers of coarse aggregate, either crushed stone or crushed concrete, fine aggregate and surface or filler blended as necessary to produce an intimate mixture, of the required gradation and stability, constructed on the prepared foundation in accordance with the specifications and in conformity with the lines, grades, thickness and typical cross sections shown on the plans or established by the Engineer.

#### **401.1(b) Materials.**

The aggregates shall conform to Part 3 of the latest edition of the Standard Specifications for Highway and Structure Construction of the State of Wisconsin, Department of Transportation, except as modified herein or in the Special Provisions of the contract.

The aggregates shall consist of hard, durable particles of crushed stone resulting from the artificial crushing of rock, boulders, large cobble stones, or concrete substantially all faces of which have resulted from the crushing operation. The material shall be free from dirt, debris, frozen materials, vegetable matter, shale, and lumps or balls of clay.

The determination of the acceptability of the aggregates will be made by field evaluation and/or laboratory test. The Engineer reserves the right to prohibit the use of material from any source, plant, pit, quarry or deposit where the character of the material or method of operation is such as to make improbable the furnishing of aggregates conforming to the requirements of these Specifications, unless satisfactory evidence is shown that material conforming to specification requirements is produced.

Unless specified in the Contract or permitted by the Engineer, crushed asphalt pavements, and mixtures thereof shall not be used for constructing Crushed Aggregate Base Course.

The aggregates shall be well graded between the limits specified and shall conform to the following gradation requirements:

<b>PERCENT BY WEIGHT PASSING</b>			
<b>Sieve Size</b>	<b>Gradation No. 1 (3" Maximum)</b>	<b>Gradation No. 2 (1-1/4" Maximum)</b>	<b>Gradation No. 3 (3/4" Maximum)</b>
9"	----	----	----
6"	----	----	----
5"	----	----	----
3"	100	----	----
2-1/2"	90 - 100	----	----
2"	----	----	----
1-1/2"	25 - 60	100	----
1-1/4"	----	95 - 100	----
1"	----	----	100
3/4"	0 - 20	70 - 93	90 - 100
1/2"	----	----	----
3/8"	0 - 5	42 - 80	40 - 75
No. 4	----	25 - 63	25 - 60
No. 10	----	16 - 48	15 - 45
No. 40	----	8 - 28	----
No. 200	----	2 - 12 see notes 1, 2	3 - 12

1. Limited to a maximum of 8% for base placed between old and new pavement.
2. 3.0 – 10.0% if base is > 50% crushed gravel.

**NOTE:**

Unless otherwise provided in the contract, aggregates for the top layer of base course shall be Gradation No. 2, and the aggregates for the bottom layer shall be Gradation No. 1. Gradation No. 3 shall be used for top dressing and final finishing.

**401.1(c) Equipment.**

Equipment and tools necessary for performing and maintaining all parts of the work, satisfactory as to design, capacity and mechanical condition for the purpose intended, must be on the job before the work is started. Any equipment which is not maintained in full working order, or which as used by the Contractor is inadequate to obtain the results prescribed, shall be repaired, improved, replaced, or supplemented to obtain the progress and quality of work contemplated by the contract.

**401.2 Construction Methods.**

**401.2(a) Preparation of Foundation.**

The foundation shall be so prepared and constructed that it will have uniform density throughout. It shall be brought to the required alignment and cross section with equipment and methods adapted for the purpose. Upon completion of the shaping and compacting operations, the foundation shall be smooth, at required density, and at the proper elevation and contour to receive the course to be constructed on it.

The right is reserved to make such minor adjustments in the finished grade line from that shown on the plans as may be necessary or desirable to maintain the characteristics of a stabilized foundation by minimizing the amount of cutting into or filling over such stabilized foundation, provided such adjustments do not impair the riding qualities, drainage, or appearance of the finished pavement or cause, in effect, a deviation from a grade established by appropriate municipal ordinance. Areas of yielding or unstable material shall be excavated and backfilled with approved material as ordered by the Engineer. This work shall be measured and paid for under the appropriate contract items, or as Extra Work, in the absence of such a contract item or items.

Base material shall not be placed on a foundation that is soft or spongy or one that is covered by ice or snow. Base material shall not be placed on a dry or dusty foundation where the existing condition would cause rapid dissipation of moisture from the base material and hinder or preclude its proper compaction. Such dry foundations shall have water applied to them and shall be reworked or recompacted if necessary.

#### 401.2(b) Spreading and Shaping.

Equipment used for spreading and shaping the crushed aggregate base course shall be designed and operated so as to spread the material in uniform layers without undue segregation. Power graders and blade graders used for spreading and shaping shall have weight, rigidity and design suitable for the work. Power graders shall have sufficient power to properly perform the work. Other types of equipment for spreading and shaping the material will be permitted, provided the work performed or produced by them is equivalent to or better than the work obtainable from blade machines. All equipment necessary for spreading and shaping, compaction, and water sprinkling of the base material shall be on the site prior to beginning the work of installing the base material.

Crushed aggregate base course shall not be installed until curbs and gutters and other concrete structures have cured per Standard Specifications to withstand hauling and placing operations. No crushed aggregate shall be placed between the curbs until the curbs have been adequately backfilled.

The material shall be deposited on the foundation or previously placed layer in a manner to minimize segregation and to facilitate spreading to a uniform layer of the required dimensions. Excessive manipulation which will cause segregation between the coarse and fine materials shall be avoided. The work shall, in general, proceed from the point on the project nearest the source of supply of the aggregate in order that the hauling equipment will travel over the previously placed material, and the hauling equipment shall be routed as uniformly as possible over all portions of the previously constructed courses or layers of the base course. Stockpiling of the aggregates shall be performed in such a manner as to facilitate the recovery of the maximum amount of stockpiled material and to minimize segregation of the material.

The crushed aggregate base course shall be constructed in two or more layers as directed by the Engineer. The material shall be spread in uniform uncompacted lifts, not to exceed five (5) inches in depth for Gradation No. 1 (3" maximum size) crushed aggregate, not to exceed three and one-half (3-1/2) inches for Gradation No. 2 (1-1/2" maximum size) crushed aggregate, and not to exceed one and one-half (1-1/2) inches for Gradation No. 3 (3/4" maximum size) crushed aggregate.

When directed by the Engineer, the Contractor shall spread a layer of Gradation No. 3 (3/4" maximum size) crushed aggregate over the subbase before the application of the Gradation No. 1 (3"



maximum size) crushed aggregate. It shall not be necessary to compact the lift of Gradation No. 3 crushed aggregate when placed directly on the subbase.

Top dressing and final finishing of the crushed aggregate base course shall be performed with Gradation No. 3 (3/4" maximum size) crushed aggregate after compaction of the surfaces of the base is complete, and after depressions and high points in the crown and along the gutter edges have been brought to grade. This material shall also be water sprinkled and compacted. The maximum compacted depth of this material shall be one (1) inch.

#### 401.2(c) Compaction and Water Sprinkling.

Prior to and during compaction operations the material shall be shaped and maintained to proper dimensions and contour by means of blade graders or other suitable equipment. The surface of each layer shall be kept true and smooth at all times.

All crushed aggregate shall be thoroughly water sprinkled before spreading begins to prevent segregation.

The crushed aggregate base course shall be placed in two or more layers, each layer being water sprinkled to the satisfaction of the Engineer to provide the required compaction. After leveling and water sprinkling, each layer of crushed aggregate shall be compacted to the degree that no further appreciable consolidation or movement of the base is evidenced under the action of the compaction equipment. The required compaction shall be attained for each layer before any material for a succeeding layer is placed thereon.

The compaction shall be performed by means of tamping rollers, pneumatic rollers, vibratory rollers, or other types of equipment which will produce the required results in the materials encountered, and be subject to the approval of the Engineer. Tandem or three wheel rollers, if used on the project, shall weigh at least ten (10) tons. Hauling and leveling equipment shall be routed and distributed over each layer of crushed aggregate in such a manner as to make use of the compaction afforded thereby.

All areas where proper compaction is not obtainable due to segregation of materials, excess fines, or other deficiencies in the crushed aggregate, shall be reworked as necessary or the material in them removed and replaced with material that will yield the required results. The complete cost of such reworking and replacement shall be at the Contractor's expense.

#### 401.2(d) Driveways.

Where shown on the plans or directed by the Engineer, the Contractor shall construct driveways of Gradation No. 2 (1-1/2" maximum size) crushed aggregate. Unless otherwise specified, driveways shall be six (6) inches in depth.

### **401.3 Measurement and Payment.**

#### 401.3(a) Method of Measurement.

The item of Crushed Aggregate Base Course shall be measured by the ton. The quantity to be measured for payment shall be the amount of material required and incorporated in the work in accordance with the contract.

The Contractor shall furnish and deliver to the Engineer a ticket with each load showing the net weight of the load of crushed aggregate. All tickets for materials delivered to a City of Madison project shall be presented to the City representative on the project within twenty-four (24) hours after delivery of the materials to the project. Tickets presented after the time specified shall be rejected due to inability to substantiate actual use of the materials on the project. Each ticket shall include the truck number and the name of the driver and a unique code identifying the driver of the truck. The code can be the driver's initials and the last four digits of the driver's social security number or the first seven digits of their driver's license. For example 'AA1234', 'F560477'.

As an alternative to furnishing individual load tickets, the contractor may submit a daily summary sheet of crushed aggregate delivered to the project. This sheet shall include project name, truck ID, tare weight, total weight and net weight for each load delivered to the site and a daily summary of total weight provided for each item. This summary sheet shall be provided to the inspector within twenty-four (24) hours after delivery of the material to the project. The actual tickets shall be made available upon request.

Aggregates which contain total moisture at the time of delivery in excess of seven (7) percent shall have moisture content in excess of seven (7) percent deducted from the measured weight. Determination of the moisture content of the aggregates shall be based on and expressed as a percent of the dry weight of the aggregates.

#### 401.3(b) Basis of Payment.

The quantity of crushed aggregate measured as provided above will be paid for at the contract unit price per ton for Crushed Aggregate Base Course, complete in place, which price shall be full compensation for furnishing, placing, watering, drying, compacting, and maintaining the crushed aggregate base course; for preparing foundation; for stockpiling, if required; and for furnishing all labor, tools, equipment and incidentals necessary to complete the work.

## **ARTICLE 402 - ASPHALT CONSTRUCTION**

---

### **402.1 Materials for Asphalt Construction.**

The materials intended for use in base, lower, and upper layer mixtures, tack and seal coats, surface treatments, and similar work, shall comply with the requirements of Part 4, "Pavements" of the latest edition of the Standard Specifications for Highway and Structure Construction of the State of Wisconsin, Department of Transportation, except as modified herein or in the Special Provisions of the contract.

Wherever the terms "Division", "Divisions", "Department" or "Departments" appear in the above mentioned specifications, such terms shall be understood to mean "City" or "City's" respectively.

The Contractor shall provide to the City the results from the Freeze / Thaw Test (AASHTO T103) for quarried course aggregates used in the work produced from limestone/dolomite sources. The maximum percent loss for aggregates used in the work shall be four percent (4%).

The Contractor shall provide Asphalt Pavement mix designs in accordance with the aforementioned Part 4 of the latest edition of the Standard Specifications for Highway and Structure Construction of the State of Wisconsin, Department of Transportation. The asphaltic materials used shall be PG64-22 for E-1 and E-3 mixes, PG58-28 for E-0.3 mixes and PG58-28 for mixes using shingles, unless otherwise specified in the Special Provisions of the contract. The Engineer reserves the right to designate a grade of asphalt at the time of construction other than that specified in the contract.

### **402.2 Placing Asphalt Mixtures.**

#### **402.2(a) Description.**

Asphalt mixtures shall not be placed when the air temperature approximately three (3) feet above ground at the site of the work, in the shade and away from the effects of artificial heat, is less than 40°F except that lower layer and base course mixtures may be placed at a lesser temperature approved by the Engineer in writing.

Asphalt mixtures shall not be placed during the calendar period between October 15th and May 1st of the next succeeding year, except with written approval or order of the Engineer. In the event of such approval or order, the conditions and restrictions as to placement set forth in the preceding paragraphs shall apply. The fact that the Engineer does not grant such approval shall not be construed as substantiating an extension of contract time for the completion of the work. Whenever such approval to extend the paving season has been denied, the Contractor shall ramp all access structures, catchbasins and water valve castings, ends of pavements, and curb edges with asphalt material to facilitate maintenance of the pavement area during the suspension of paving operations. Prior to the installation of succeeding layers of asphalt pavement, all such ramping shall be removed as directed by the Engineer and disposed of by the Contractor. All costs of installing and removing such ramping shall be at the Contractor's expense.

When placing of asphalt paving mixtures is continued after October 15th, either at the request of the Contractor or with the Engineer's approval in order to complete the work to the stage required by the provisions of the contract, the asphalt paving work so performed will be construed to have been done at the Contractor's risk. Final inspection thereof will be deferred until May of the succeeding year. Prior to final acceptance of pavement so placed, the Contractor shall repair, restore or replace at no

additional cost to the City and in a manner approved by the Engineer, all damage or defects in the asphalt paving which, in the opinion of the Engineer, are attributable to temperature and weather conditions which prevailed after October 15th or before May 1st, as the case may be.

After all layers have been thoroughly compacted, they may be tested for smoothness by means of a fourteen (14) foot straightedge placed parallel to the center line of the pavement, parallel to the grade line in each lane, and touching the surface. Ordinates measured from the face of the straightedge to the lower layer shall at no place exceed one-fourth (1/4) inch. Variations exceeding one-fourth (1/4) inch in the lower layer shall be corrected as directed by the Engineer. Ordinates measured from the face of the straightedge to the upper layer shall not exceed one-eighth (1/8) inch. For each variation in the upper layer greater than one-eighth (1/8) inch but less than one-fourth (1/4) inch, where directed by the Engineer, the area affected shall be removed and replaced with fresh upper layer mixture at the expense of the Contractor. If variations in the upper layer exceed one-fourth (1/4) inch, the entire area affected shall be removed and replaced with fresh upper layer mixture at the expense of the Contractor.

The Contractor shall be responsible for and maintain the work during the several stages of construction and until the acceptance thereof. Such maintenance shall include protection and repair of the foundation, tack coat, base, and surface. Any rich or bleeding areas, any breaks, any raveled spots, or other unsatisfactory areas shall be corrected during such maintenance period.

The Contractor shall protect all sections of the newly placed and compacted mixture from traffic until the material has cooled and hardened to the satisfaction of the Engineer. The Contractor shall furnish, install and maintain barricades to protect the surfaces tack coated and the pavement laid from traffic. Barricades may be removed only with the Engineer's approval. Barricades and fencing shall be designed and installed so as not to mark or otherwise damage the completed pavement.

Paving equipment shall not be cleaned with kerosene, fuel oil or gasoline on newly laid asphalt pavement, crushed stone base course prepared for asphalt pavement, or on existing asphalt pavements, unless the pavement or base is protected with a material, acceptable to the Engineer, which shall prevent cleaning oils or fluids from coming in contact with the pavement or base.

The Contractor shall maintain on the project suitable fire fighting equipment, or other equipment of similar purpose, and an adequate supply of hand brooms, shovels, mechanical tampers, hand tampers, lutes, and iron rake for use at places which are inaccessible to pavers and rollers. The Contractor shall not commence paving on each day unless the above equipment is on the paver or readily available for use. A steel plate will also be required and utilized when paving over open grates and inlets.

Prior to beginning the installation of the asphalt upper layer on any project, the Contractor shall complete the final adjustment of all water valve castings to finished grade.

The Contractor shall thoroughly clean all hard surfaces immediately before applying tack material to areas overlaid with HMA mixtures. Such cleaning to remove all dust, debris, or other objectionable material shall be done using a street sweeper with vacuum or regenerative pickup head or equal. Unsatisfactory areas shall be hand cleaned by sweeping or compressed air as directed by the Engineer.

#### 402.2(b) Personnel.

The Contractor shall provide competent workers who are capable of performing the duties assigned to them in the work of placing and compacting asphalt mixtures in accordance with the specifications. The paving crew shall be under the supervision of an experienced supervisor who shall be on the project at all times, and who shall not operate equipment, such as paving machines or rollers, at any time during the paving operation. Under no circumstances shall the workers, or others, be allowed to walk across recently laid asphalt mixture behind the paving machine and ahead of the roller.

#### 402.2(c) Equipment.

A mechanical vibratory plate compactor shall be available on the job site at all times during asphalt pavement placement and shall be used for compaction around access structures, catchbasins, water valves and other castings which appear in the paved areas. The mechanical vibratory plate compactor shall be equipped with a working water reservoir and shall be of sufficient size and capability to attain the compaction requirements of these specifications.

#### 402.2(d) Spreading and Finishing.

Pave at a constant speed, according to the paver specifications and mixture, for uniform spreading and strike-off with a smooth, dense texture and no tearing or segregation.

In any event, the speed of placing asphalt mixtures shall not exceed that which coincides with the average rate of delivery to the paver, so as to provide as nearly as possible continuous operation of the paver.

The roller shall pass over an unprotected end of freshly laid mixture only when the laying of the course is to be discontinued long enough to permit the mixture to become cooled. In the event of such discontinuance, the end of the course shall be treated as a transverse construction joint as specified below.

#### 402.2(e) Compaction.

Where the edges are not supported by a curb and gutter or similar structure, the outside edges of the lower and upper layers shall be sloped and pressed in place by means of a self adjusting constant pressure edge plate held in proper position on the finishing machine. A string line shall be used as a guide for the finishing machine in order to maintain a uniform edge alignment. If any other method is used, it shall meet the approval of the Engineer. The edge of the pavement shall be sloped approximately one (1) inch from the vertical and no material shall extend beyond the limits of the base. Irregularities in alignment along the outside edges and along the longitudinal joints shall be corrected by adding or removing paving mixtures before the edges are rolled.

The mixture shall be spread sufficiently so that after compaction the finished surface shall be one-eighth (1/8) to one-fourth (1/4) inch above the edges of curbs, gutters, access structures and similar structures.

Each roller, while the paving is under way, shall be kept as nearly as practicable in continuous operation and the speed shall at all times be slow enough to avoid undue displacement of the mixture. When pneumatic-tired rollers are used, they shall be operated continuously at a rate of speed which

will not cause damage to the mat and which will provide the maximum number of coverages possible while the temperature of the mat is conducive to densification and surface sealing. Rollers shall be operated with the drive roll or wheels nearest the paver.

<b>MINIMUM REQUIRED DENSITY*</b>		
<b>Layer</b>	<b>Percent of Target Maximum Density</b>	
	<b>Mixture Type</b>	
	<b>E-0.3, E-1, E-3</b>	<b>E-10</b>
Lower	91.5	92.0
Upper	91.5	92.0

**402.2(f) Joints.**

Longitudinal joints including mainline interior joints for all pavement layers shall be “hot” joints. “Hot” joints will be defined as joints with a temperature at or above the asphalt mixture compaction temperature. The Contractor shall provide the compaction temperature as part of the mix design submittal.

Where reheating of joints is needed to create a “hot” joint, reheating equipment and methods shall be in accordance with the latest edition of the Standard Specifications for Highway and Structure Construction of the State of Wisconsin, Department of Transportation, specifically Reheating HMA Pavement Longitudinal Joints, Item 460.4100S.

Where “Michigan” joints are placed to allow traffic use, the joint shall be milled, reheated and tacked in accordance with the above stated reheating specification before continuation of paving.

Contractor’s operations shall not result in additional transverse joints unless approved by the Engineer.

**402.3 Asphalt Pavement.**

Unless otherwise specified or directed by the Engineer, asphalt driveways and asphalt terrace paving shall be constructed of three (3) inches of upper layer pavement installed in one (1) lift on select fill, or as directed by the Engineer. E-0.3 mixture with 9.5mm nominal aggregate size or an approved commercial mix shall be used, unless a substitute is approved by engineer.

The composition for the various asphalt mixtures shall conform to the limits specified in Part 4 of the latest edition of the Standard Specifications for Highway and Structure Construction of the State of Wisconsin, Department of Transportation, except as modified herein or in the Special Provisions of the contract. Warm mix HMA is not approved.

The mixture shall be laid and compacted so that the average yields in pounds per square yard shall conform to the following charts showing the various thicknesses of installation:

Unless otherwise specified in the contract, or directed by the Engineer, the upper layer mixtures shall be installed in one course of one and one-half (1-3/4) inches in depth.

<b>UPPER &amp; LOWER LAYER(S) YIELD - #/S.Y.</b>		
<b>Thickness</b>	<b>Min.</b>	<b>Max.</b>
1.5"	172	180
1.75"	201	210
2"	230	240
2.5"	287	300
3"	345	360
4"	460	480
5"	575	600

For installations of the upper layer which are specified to be other than one and one-half (1-1/2) inches in depth, the allowable yields for such installations shall be in proportion to the allowable yields specified above.

Whenever the yields fall below the minimum allowable yields specified above, the Engineer shall determine the corrective action to be taken. The corrective action may include removal and replacement of the area of deficient thickness, an overlay with approved material of the area of deficient thickness, or such other action as the Engineer shall determine including a reduction in payment up to 50% of the unit price for the deficient amount. The area of deficient thickness shall be determined on the basis of street area, project area, or area covered in one day's operation, whichever is less. The Engineer's determination will be based on the circumstances of the area involved, and will include a determination of the distribution of costs of the corrective work required.

#### Recycled Asphaltic Materials

The contractor may use recycled asphaltic materials from FRAP, RAP, and RAS in HMA mixtures. Stockpile recycled materials separately from virgin materials and list each as individual JMF components.

Control recycled materials used in HMA by evaluating the percent binder replacement, the ratio of recovered binder to the total binder. Conform to the following:

<b>MAXIMUM ALLOWABLE PERCENT BINDER REPLACEMENT</b>		
<b>Recycled Asphaltic Material</b>	<b>Lower Layers</b>	<b>Upper Layer</b>
RAS if used alone	25	20
RAP and FRAP in any combination	40	25
RAS, RAP and FRAP in combination*	35	25

\*When used in combination the RAS component cannot exceed 5 percent of the total weight of the aggregate blend.

#### **402.4 Asphalt Tack Coat.**

Unless otherwise specified in the contract, or directed by the Engineer, the types and grades of asphalt materials and rates of applications in gallons per square yard shall conform to the following requirements:

1. The tack coat material shall be type MS-2, SS-1, SS-1h, CSS-1, or an approved modified emulsified asphalt.

2. For existing concrete or asphalt pavements, the rate of application shall be between 0.05 and 0.10 gallons per square yard.

#### **402.5 Recycled Asphalt Pavement.**

This work shall consist of the construction of a plant mixed recycled asphalt mixture furnished and placed all in accordance with Article 460 of the latest edition of the Standard Specifications for Highway and Structure Construction of the State of Wisconsin, Department of Transportation, except as listed below.

The City of Madison shall approve the sources of recycled asphalt material, including shingles.

#### **402.6 Measurement and Payment.**

##### **402.6(a) Asphalt Pavement Mixtures.**

Asphalt mixtures of the type or types included in the contract, shall be measured by the ton of mixed aggregate and asphalt material, or by the square yard of area paved. The quantity measured for payment shall be the amount of material furnished, delivered to and incorporated in the accepted work, or the area paved, including cleaning and maintenance, and for all labor, tools, equipment, and incidentals necessary to complete the work contemplated by the contract. Deductions shall be made for any quantities which are wasted, which are not actually incorporated in the work in accordance with the contract, and for those materials which do not conform to the requirements of these specifications.

Asphalt mixtures intended for use on City projects will be tested by the City in order to determine aggregate gradations, asphalt content, air voids and VMA. Asphalt mixtures shall be tested per section 460.2.8 of the latest edition of the Standard Specifications for Highway and Structure Construction of the State of Wisconsin, Department of Transportation.

When the average yield on a project exceeds the maximum allowable yield, as specified in Section 402.3, all excess material shall be paid for at the rate of one-half (1/2) the contract unit price for the type of material involved. The average yield for this purpose shall be computed on a daily basis, a project basis, or a street area, whichever covers the smallest area of paving.

When the average yield on a project is below the minimum yield allowable, as specified in Section 402.3, the quantity of material below the minimum shall be paid at a rate no less than one-half (1/2) the contract unit price for the type of material involved if required by the Engineer. The average yield for this purpose shall be computed on a daily basis, a project basis, or a street area, whichever covers the smallest area of paving.

The Contractor shall furnish and deliver to the Engineer a ticket with each load showing the net weight of the load of crushed aggregate. All tickets for materials delivered to a City of Madison project shall be presented to the City representative on the project within twenty-four (24) hours after delivery of the materials to the project. Tickets presented after the time specified shall be rejected due to inability to substantiate actual use of the materials on the project. Each ticket shall include the truck number and the name of the driver and a unique code identifying the driver of the truck. The code can be the driver's initials and the last four digits of the driver's social security number or the first seven digits of their driver's license. For example 'AA1234', 'F560477'.



As an alternative to furnishing individual load tickets, the contractor may submit a daily summary sheet of crushed aggregate delivered to the project. This sheet shall include project name, truck ID, tare weight, total weight and net weight for each load delivered to the site and a daily summary of total weight provided for each item. This summary sheet shall be provided to the inspector within twenty-four (24) hours after delivery of the material to the project. The actual tickets shall be made available upon request.

#### 402.6(b) Asphalt Tack Coat, and Asphalt Seal Coat.

The asphalt materials required for and incorporated in the work of applying asphalt tack coat or in the work of constructing Asphalt Seal Coat shall be measured by volume in gallons as provided in the contract. Deductions shall be made for any quantities which are wasted or are not actually incorporated in the work in accordance with the contract.

The quantity of asphalt material measured as provided above will be paid for at the contract unit price per gallon for the item of asphalt tack coat, which price shall be full compensation for furnishing; heating, unloading, hauling, and applying the asphalt material; for maintenance of the tack coat; and for all labor, tools, equipment, and incidentals necessary to complete the work contemplated by the contract.

The quantity of asphalt material measured as provided above will be paid for at the contract unit price per gallon for the item of asphalt material for seal coat, which price shall be full compensation for all work required for the cleaning and sweeping of the existing surface, for furnishing, heating, unloading, hauling, and applying the asphalt material; and for all labor, tools, equipment and incidentals to complete the work of applying the asphalt material required for the seal coat and maintaining such work.

#### 402.6(c) Aggregate for Seal Coat Cover.

Aggregate for seal coat cover furnished and incorporated in the work in accordance with the contract shall be measured by the ton.

The quantity of aggregate for seal coat cover, measured as provided above, shall be paid for at the contract unit price per ton for said item, which price shall be full compensation for furnishing, processing, drying, transporting and spreading the aggregate; for brooming, rolling, finishing, and maintaining the surface; and for all labor, tools, equipment, and incidentals necessary to complete the work.

#### 402.6(d) Asphalt "Hot" Joints.

Asphalt heating equipment, labor, tools and methods required to keep or create "hot" joints shall be incidental to asphalt pavement mixtures unless otherwise specified in the special provisions.

## ARTICLE 403 - RESURFACING

---

### 403.1 General.

The following specifications cover the work involved in the asphalt pavement resurfacing program of various streets. The resurfacing program includes: contract(s) to replace curb & gutter and utility castings; grind or pulverize various streets; patch and resurface various streets.

The proposed listing of streets and proposed quantities of work listed in the contract shall be subject to additions or deletions by the Engineer. The Engineer shall give written notice to the Contractor of any such additions or deletions. The work to be done on the various streets shall be itemized on "standard walk sheets" included in the Special Provisions.

The City of Madison reserves the right to add or delete streets from the contract dependent on funds available. The Contractor shall not be entitled to additional compensation in the event streets are added or deleted.

The City reserves the right to decrease or increase any of the quantities of the items bid upon without any change in the unit price bid, unless by mutual agreement by both the Contractor and the City.

If the quantities of any item is reduced, such decrease **SHALL NOT** constitute a claim for damages by the Contractor for loss of anticipated profits, **NOR** shall the Contractor be compensated for any overhead, equipment, material and labor charges, or any other costs incurred in the expectation of any quantity of work originally estimated in the Contract.

The various public and private utilities, including, but not limited to, sanitary sewers, storm sewers, water, gas, electric, telephone, traffic signals, street lighting, and cable television, may have facilities within the limits of the streets to be resurfaced which will require repairs or alterations. All such repairs or alterations which are required shall be completed before the installation of the asphalt upper layer. The Contractor shall so schedule his work that those utilities which have to make repairs or alterations to their facilities will not cause the final completion date of all work included with the contract to extend beyond the specified time of completion.

The Contractor shall so schedule its work with the Engineer so as not to interfere with the work of other concurrent City contracts for reconstructing curb and gutter, base patching, adjusting utility castings, grinding, or paving of the various streets. All other work shall be completed on the street prior to starting the paving operations, unless otherwise approved by the Engineer.

If a specific operation (i.e., grinding) will not take place within two (2) days of the preceding specified operation (i.e., base patching) the Contractor shall remove the No Parking signs and re-post the No Parking signs before the next specific operation begins.

The Contractor shall notify the Traffic Engineer at 266-4761 before moving to and starting work on each of the various streets. The Contractor shall also notify the bus utility before starting work on a designated bus route.

The Contractor shall notify the Engineer daily of all work to be performed. If the Contractor performs work without notification of the Engineer said work and materials shall be at no cost to the City. The Contractor shall designate one person on each work crew, including subcontractors, to supervise the work crew and to be responsible to the Engineer for traffic control settings, marking

and measuring work, acquisition of construction materials, systematic scheduling, etc. The said designated person shall be familiar with the work and may be a member of the work crew.

All traffic signing and barricading shall conform to the Federal Highways Administrations “Manual on Uniform Traffic Control Devices” (MUTCD) and City of Madison Supplements for sidewalk and bikeway closures and the State of Wisconsin Standard Detail Drawing S.D.D. 15c 11-5.

The Contractor shall submit an acceptable Traffic Control Plan and a list of names and emergency phone numbers for individuals who are responsible for the maintenance of traffic control for this project to the office of the City Traffic Engineer, a minimum 48 hours prior to the start of work on this project.

Section 107.7 - Maintenance of Traffic, Section 107.8 - Notification when Closing Street, Section 107.9 – Barricades, Warning Signs and Flagging and Section 107.10 – Opening of Section of Highway to Traffic shall govern over Section 403.1 paragraphs six through twelve.

On street parking may be removed by the contractor to facilitate construction, resurfacing and maintain traffic flow. The contractor shall notify the traffic Engineering Division, forty-eight (48) hours in advance of proposed parking removal. The contractor shall obtain from the City and place “No Parking” portables, “No Parking” cardboard signs or meter bags whichever is applicable for the particular street. “No Parking” restrictions must be placed a minimum of 48 hours in advance of the beginning of construction. On streets where Zone Parking, (2-hour) is in effect or signed loading zones in effect, the contractor shall cover these signs with black plastic bags when No Parking portables or signs are placed in the same area.

On streets where there is not time restriction on parking, the Contractor shall post said streets at least forty-eight (48) hours prior to beginning work with “No Parking” signs legibly marked with the date and time of restricted parking. The Contractor shall notify the Police Department Traffic Bureau at 266-4622 during regular hours or the Police Dispatcher after regular hours stating the construction company name, the contract number, the street or streets posted, the time and date posted, and shall request that Police Department Personnel check the posting.

On all streets where there is a time restriction on parking, the Contractor shall post said street at least twelve hours prior to beginning work with “No Parking” signs legibly marked with the date and time of restricted parking. The Contractor shall notify the Police Department Traffic Bureau the same as above.

On streets where residential permit parking is allowed, the Contractor shall post said street at least forty-eight (48) hours prior to beginning work with “No Parking” signs legibly marked with the date and time of restricted parking. Residential permit parking zones are indicated with a zone number located in the lower corner of the permanent time restriction sign. The Contractor shall notify the Police Department Traffic Bureau the same as above.

The Contractor shall post “no parking” signs at the beginning, midpoint, and the end of each block plus additional signs as needed. “No parking” signs shall be posted a minimum of three (3) feet above curb elevations. If no work is begun on the posted street within two (2) days of the posted start date, the Contractor shall remove the “no parking” signs and repost the street when ready to begin work on that street.

The Contractor shall be responsible for erecting, re-erecting, maintaining, and removing those “No Parking” controls devices stated above.

The Contractor shall maintain two-way traffic on all two-way streets governed by the contract. Traffic lanes shall be a minimum of eleven (11’) feet in width. When necessary, because of certain construction operations, the Contractor may reduce the roadway width to twelve (12’) feet with two way traffic maintained by flag persons in accordance with the Federal Highways Administration “Manual on Uniform Traffic Control Devices” (MUTCD).

Construction on one way streets will require a minimum fifteen (15’) feet traffic lane.

The Contractor shall observe peak hour traffic restrictions on certain streets between the hours of 7:00 A.M. to 8:30 A.M. and 4:00 P.M. to 5:30 P.M. Peak hour traffic restrictions apply to all signalized intersections and arterial streets. During these hours, no work shall be performed in or adjacent to the roadway where traffic is being maintained or deliveries being made to the site that will in any way interfere with the movement of traffic. The list of streets with peak hours restrictions shall be listed in the Special Provisions. Exceptions to this time restriction require approval of the Engineer.

All openings made in the existing base course shall be backfilled or plated on the same day as the base course is removed. Temporary backfilling and the removal and disposal of temporary backfill material shall be at the expense of the Contractor.

The Contractor shall furnish, install and maintain all provisions for traffic control as specified in Article 107 of these specifications. The Contractor shall also furnish, install and maintain additional traffic control devices as specified in the special provisions of the contract or as directed by the Engineer in order to control and divert traffic to the proper travel lanes of the street being worked on.

The Contractor shall provide a pickup, a stake truck, or a similar vehicle designated for the sole purpose of transporting traffic control devices. One person, or more as needed, on each work crew, including subcontractors, shall be designated to properly set up traffic control devices, to maintain and move them as needed, and to pick up the traffic control devices at the end of the work day or when the work is completed. This designated person can also function as a flag person as needed provided the traffic control devices are in position. The said person designated for traffic control shall be familiar with the work.

Electric lighting (Type A flashers) shall be used for lighting of all work areas. Type II barricades shall be used for all work in the street, sidewalk, drive apron, including castings and curb and gutter area. The Contractor shall protect all work as required until after the installation of approved wedging. The Contractor shall be responsible for and shall furnish wedging to protect the adjusted castings until the roadway is paved. Wedging shall consist of cleaning the surface area around the casting, tacking the entire surface area to be wedged, and placing hot mix asphalt mixture compacted to a depth within one-quarter (1/4) inch of the top of the adjusted casting and to a minimum radius width of one (1) foot for each one-half (1/2) inch of adjusted vertical height, or as directed by the Engineer. All costs for protecting and wedging castings shall be incidental to the contract unless specified.

All cost pertaining to the above Traffic Control work shall be paid under **BID ITEM 10701 - TRAFFIC CONTROL.**

The time of completion of the work shall be in work days. A work day shall be any calendar day during which weather and other conditions not under the control of the Contractor will permit construction operations to proceed for at least six (6) hours of the day with the normal working force engaged in performing the work in progress at this time. Days when less than six (6) hours of work is performed shall be considered 1/2 work days in the time of completion. It shall be considered a work day whether any single operation is being performed such as casting adjustments, or whether multiple concurrent operations are being performed. Only when approved by the Engineer in writing in advance shall contract time not be assessed during complete suspension of operations. If operations are suspended with approval of the Engineer, the Engineer shall also state in writing to the Contractor the date that operations shall resume. Work days from this date on shall be included in the time of completion.

The Contractor shall limit his work day to 7:00 P.M. unless otherwise approved by the Engineer in writing. All rolling of new pavements, brooming and cleaning up of debris, and removing the traffic control devices shall be completed by this time, or as designated by the Engineer. No Sunday or legal holiday work will be allowed and no contract time will be assessed for Sundays and legal holidays not worked.

The Contractor shall contact any railroad involved at least seventy-two (72) hours before starting work in a railroad track area. The Contractor shall request the railroad to furnish a flag person for the railroad crossing work. As directed by the Engineer, the Contractor shall excavate between the rails to the ties, remove and salvage any existing mud rails to the railroad, and backfill with asphalt paving materials. No crushed stone will be allowed on the railroad ties. The patch area, including between the rails, shall be measured and paid for as asphalt base patch. Removing rails and ties completely shall be considered extra work. No work days will be charged for any railroad work that extends beyond the completion of all other work included with this contract.

Replacement castings for storm and sanitary sewers and steel adjusting rings shall be picked from the casting storage at the Engineering Service Building, 1602 Emil Street. The Contractor shall notify the Engineering Service Building at telephone number 266-4430 at least one day in advance when new castings are required. Replacement castings for Water Utility valve access structures shall be picked up from the casting storage at the Water Utility Operations Center, 110 South Paterson Street. The Contractor shall notify the Water Utility Operations Center at telephone number 266-4661 at least one day in advance when new castings are required. Replacement castings for Traffic Engineering electrical utility access structures shall be picked up from the casting storage at the Traffic Engineering Shop, 1120 Sayle Street. The Contractor shall notify the Traffic Engineering Shop at telephone number 266-4767 at least one day in advance when new castings are required. The castings which are replaced shall be the property of the City. The Contractor shall haul such replaced castings to the Engineering Service Building storage area at 1602 Emil Street and deposit the castings as directed by the person in charge of the storage area.

All work done in the vicinity of any tree located in the terrace shall be completed in accordance with section 107.13 Tree Protection Specification.

## **403.2 Grinding.**

### **403.2(a) Description.**

Grinding shall consist of “milling”, or “cold planning” the existing pavement surface to establish a new surface profile and cross section in preparation for an asphalt overlay. The surface after grinding

shall have a grooved or ridged finish, uniform and resistant to raveling or traffic displacement. This textured surface shall have grooves of one-fourth (1/4) inch (+1/8"). The existing surface to be ground shall include asphalt pavement, concrete utility patches and small amounts of concrete pavement.

The grinding machine shall be a power operated, self-propelled machine, having a cutting drum with lacing patterns that will attain a grooved surface and produce grinding chips of less than two (2) inch in size. The grinding machine shall be equipped with a pressurized watering system for dust control. The equipment shall be of the type that has successfully performed similar work.

The Contractor shall use only approved grinders or milling machines for removing existing pavement failures so as not to disturb the existing subbase.

The cleaning equipment shall be of the type to efficiently remove all loosened material and load into trucks for hauling and spreading. Because of the nature of the streets to be ground and the traffic restrictions, a belt loader followed by a power sweeper and manual sweeping is most desirable. Flushing into the City's storm sewer system as a means of cleanup will not be allowed.

The Contractor shall haul the grindings from the milling operation to the Badger Road and Sycamore Avenue Street Division facilities, or where directed by the Engineer. The grindings shall be stockpiled or tailgate spread as directed. When specified in the contract or directed by the Engineer, the Contractor shall dispose of any undesirable or excess grinding material. The Contractor shall furnish the Engineer a daily load count for the removed material.

Wedge cut grinding shall consist of grinding the existing pavement surface a minimum of four (4) feet wide at the existing concrete gutter. The edge of gutter end of the finished wedge cut shall match the depth of the new asphalt overlay with a minimum one and three-quarters (1-3/4) inches below the edge of existing concrete gutter. The center-line-of-street edge of the wedge cut shall be cut one-eighth (1/8) inch. This item shall also include scoring the existing pavement surface at locations specified by the Engineer. Ramping water valve boxes shall be considered incidental work to wedge cut grinding. Ramping utility castings shall be paid for under with **BID ITEM 40308 - RAMPING SAS**.

Full width grinding shall consist of grinding the existing pavement surface from edge to edge of gutter a minimum of one and three quarter (1.75) inch or as directed by the Engineer. Ramping water valve boxes shall be considered incidental work to full width grinding. Ramping utility castings shall be paid for under with **BID ITEM 40308 - RAMPING SAS**.

Base Patch grinding may be specified as the acceptable method to remove existing pavement and base failures as part of the work for base patch grinding. The Contractor shall grind patches to the width and length as marked in the field by the Engineer and recorded on the standard walk sheets. The minimum width of patches for removal by grinding shall be six (6) feet. There will be no minimum length. Fill shall be an approved asphalt material. Any additional width or depth, unless approved by the Engineer, shall be at the Contractor's expense and restored to the designated width and depth of patch with asphalt lower layer material at no cost to the City.

There will be three (3) approved methods. Method #2 shall consist of 2" Grinding filled with 2" Asphalt Upper Layer material, Method #3 shall consist of 3-1/2" Grinding filled with 3-1/2" Asphalt Upper Layer material, Method #5 shall consist of 5" Grinding with 3-1/4" Asphalt Lower Layer

material and 1-3/4" Asphalt Upper Layer material. Patches shall be started and completed in the same day.

Pavement joint grinding shall consist of grinding or saw cutting and removing the existing asphalt overlay to expose the base course joint as directed by the Engineer. The Contractor shall remove and dispose of all loose and deleterious material including broken concrete. The joint exposure shall be a minimum of eighteen (18) inches wide. Small or "mini" grinders are preferred for this work. The Contractor shall thoroughly clean and tack the exposed joint and place and compact the asphalt backfill material to one-half (1/2) inch above the existing asphalt surface. Any width greater than eighteen (18) inches shall be approved by the Engineer.

Grinding around utility castings to the depth of cut before and after encountering the castings shall be included in the area of the pavement surface ground. The Contractor may choose to remove the entire existing asphalt pavement around the castings where grinding is not completed and replace it with an asphalt mixture placed and compacted in three (3) inch lifts. The Contractor shall vertically cut the limits of area to be patched, mechanically compact the existing base course and tack the bottom and vertical edges before backfilling. All costs for the alternate to grinding around castings shall be considered incidental to grinding.

Any butt joint greater than one (1) inch shall be ramped with hot-mix asphalt material as directed by the Engineer. All castings exposed by grinding shall be ramped with hot-mix material before opening to traffic. Small or mini grinders are required for this work.

Ramping SAS shall consist of cleaning the surface area around the casting, tacking the entire surface area to be wedged, and placing hot mix asphalt mixture compacted to a depth within one-quarter (1/4) inch of the top of the adjusted casting and to a minimum radius width of one (1) foot for each one-half (1/2) inch of adjusted vertical height, or as directed by the Engineer.

#### 403.2(b) Measurement and Payment.

Wedge cut grinding shall be measured by the square yard of pavement surface ground measured from the edge of concrete gutter to a maximum of four (4) feet from the edge of gutter. The depth of cut shall be determined by measuring to the top of the ridges by placing a five (5) foot straight edge perpendicular to the grooving pattern. On wedge cuts, widths of grinding greater than four (4) feet shall be at the Contractor's expense. Widths less than four (4) feet shall be measured by the square yard of actual area of pavement surface ground. The Contractor shall grind all butt joints eight (8) foot wide and to a depth of one (1) inch, or as directed by the Engineer. Any butt joints ground greater than one (1) inch shall be ramped with approved material as directed by the Engineer. All costs for ramping butt joints shall be considered incidental to grinding.

Full width grinding shall be measured by the square yard of actual pavement ground to a minimum depth of one (1) inch. Any additional depth of existing pavement removed to obtain the depth necessary to allow for the proposed overlay shall be considered incidental to full width grinding. Any butt joints ground greater than one (1) inch shall be ramped with approved material as directed by the Engineer. All costs for ramping butt joints shall be considered incidental to grinding.

Full width and wedge cut grinding will be paid for at the contract unit price bid for Full width and wedge cut grinding respectively, which price shall be full compensation for grinding the existing pavement surface including around utility castings, disposal of material, for street cleaning and for all equipment, tools, labor and incidentals necessary to complete the work in accordance with this

contract. Ramping water valve boxes shall be considered incidental work to wedge cut grinding and full width grinding. Ramping utility castings shall be paid for under with **BID ITEM 40308 - RAMPING SAS.**

Base patch grinding shall be measured by the square yard for patches ground to the width and length as marked in the field by the Engineer. The area, measured as provided above, shall be paid for at the contract unit price per square yard for the specific Method of Base Patch Grinding, which price shall be full compensation for grinding and disposal, backfilling with asphalt material as provided above and for all labor, tools, equipment and incidentals necessary to complete the work.

Pavement joint grinding shall be measured in lineal feet and paid for at the contract unit price bid for pavement joint grinding. The unit price bid shall include all costs for grinding or saw cutting, removal and disposal of the existing asphalt overlay to expose the base course joint, cleaning and tacking the joint, furnishing and placing backfill material, finishing and protecting, and for all labor, tools, equipment and incidentals necessary to complete the work.

Ramping SAS shall be measured as units of each and paid for at the contract unit price bid. The unit price bid shall include all costs for cleaning and tacking the surface to be wedged, supplying, placing and compacting hot mix asphalt mixture as described above including finishing and protecting, and for all labor, tools, equipment and incidentals necessary to complete the work.

### **403.3 Pulverize and Shape.**

#### **403.3(a) Description.**

This work shall consist of pulverizing the existing asphalt surface and a portion of the crushed stone base course to a blended uniform well-graded material. The pulverized material shall be reduced to a minimum of 97 percent passing a 2-inch screen. The pulverized material shall than be graded and reshaped as directed by the Engineer to provide for the required depth of asphalt pavement.

For a compacted lift thickness of pulverized material, up to 6-inches, compaction equipment shall be in accordance with Section 401.2 of the Standard Specifications.

For a compacted lift thickness of pulverized material, greater than 6-inches and up to 8-inches, a minimum 25,000-pound pad foot vibratory roller and a minimum 8-ton vibratory steel roller shall be used.

Butt joints shall be sawcut and ramped with pulverized material for depths greater then 1”(inch). Before the grading and shaping operation begins, the pulverized aggregate shall be watered sufficiently to provide the required stabilization and compaction of this material.

Unless otherwise approved by the engineer a minimum of 50% of the asphalt pavement shall be utilized as part of the finished base. If more than 50% is removed there shall be no additional compensation to the contractor.

The Contractor shall remove excess material.

#### **403.3(b) Method of Measurement.**

Pulverize and shape shall be measured by area in square yards of surface pulverized and shaped.



403.3(c) Basis of Payment.

The square yard area for pulverize and shape, measured as provided above, shall be paid for at the contract unit price per square yard, which price shall be full compensation for all preparation and any special construction required, removal of excess material, and for all labor, tools, equipment and incidentals necessary to complete the work including disposal of surplus material.

**403.4 Undercut.**

403.4(a) Description.

If base problems are encountered, undercut may be required. Undercut of depths up to 1' shall be measured in square yards. Depths over 1' shall be paid as an additional undercut for each (undercut excavation - 1' in depth). Excess pulverized material may be used for backfilling the undercut areas, placed in 6" lifts and compacted.

Where directed by the Engineer, crusher run (Breaker) shall be used for backfilling undercut areas placed in six (6) inch lifts and compacted. Placement of crusher run shall be paid under **BID ITEM 20219 - BREAKER RUN**.

403.4(b) Method of Measurement.

Undercut shall be measured by area in square yards of surface excavated.

403.4(c) Basis of Payment.

The square yard area for undercut, measured as provided above, shall be paid for at the contract unit price per square yard, which price shall be full compensation as provided above and in accordance with Article 201 Excavation Cut of the Standard Specifications.

**403.5 Asphalt Tack Coat.**

The Contractor shall apply asphaltic tack coat to streets prior to placing asphalt pavement as directed by the Engineer. No tack coat shall be placed on the base course unless directed by the Engineer. In accordance with Section 402.4, the Contractor shall apply an asphaltic tack coat to all butt joints and all longitudinal joints meeting both existing pavements and new pavements on successive paving passes. All costs for furnishing and applying tack coat to butt joints and longitudinal joints as specified above shall be considered incidental to the bid item for asphalt tack coat.

**403.6 Asphalt Lower Layer.**

Asphalt lower layers shall consist of furnishing and placing asphalt pavement in accordance with Article 402.

The Contractor shall be responsible for the preparation of the street surface to be paved. Preparation shall include the removal of all asphalt patches, asphalt crack filler, vegetation along gutter edges, leaves, dirt, debris, etc. It shall be the Contractor's responsibility to assure proper cleaning of the street surface before tacking and paving. On all streets, the Contractor shall tack and fill any existing large voids with hot mix asphalt and compact the filler material before paving. All costs for filling large voids in existing pavement shall be incidental to asphalt lower layer. Where designated by the Engineer, the Contractor shall wedge low areas of the existing pavement with hot mix asphalt.

Wedging shall be completed prior to paving. The cost for wedging shall be paid for at the unit price for asphalt lower layer. Material used for wedging shall not be included in the quantity for computing yield.

Yield requirements shall be adhered to.

#### **403.7 Asphalt Upper Layer.**

Asphalt upper layer shall consist of furnishing and placing asphalt pavement in accordance with Article 402.

Yield requirements shall be adhered to.

#### **403.8 Asphalt Base Patching.**

##### **403.8(a) Description.**

Asphalt base patching for the removal of pavement failures includes pavements on concrete base course and on crushed stone base course. The Contractor shall verify as to whether the proposed streets listed have existing concrete or crushed stone base course. When specified in the contract, the Contractor shall perform base patching by grinding with the removal of existing pavement failures in accordance with Section 403.2. All other base patching shall be excavated by backhoe or other approved equipment so as to minimize disturbing the existing subbase.

The depths of removal by backhoe of the pavement failures as determined by the Engineer and indicated on the standard walk sheets shall be three and one-half (3-1/2) inches, five (5) inches, eight (8) inches, and ten (10) inches. The removal by backhoe of pavement failures to a depth of five (5) inches is intended to include existing asphalt pavements on crushed stone base course. If concrete base course is encountered when removing the asphalt pavement failures on crushed stone base course, the Contractor shall notify the Engineer before removing the existing concrete material for the Engineer to change the classification to eight (8) inch patching or the base patch will be paid for at the depth and area listed on the standard walk sheet.

The removal by backhoe of pavement failures to a depth of eight (8) inches is intended to include existing asphalt pavements with concrete base course, and concrete pavements on crushed stone base course. If steel reinforcement is encountered, the Contractor shall cut all reinforcing steel flush to the patch limits. When the depth of removal necessary to remove the concrete base course or concrete pavement is greater than ten (10) inches, the Contractor shall notify the Engineer before removing the existing concrete material for the Engineer to change the classification to ten (10) inch patching or the base patch will be paid for at the depth and area listed on the standard walk sheet.

The Contractor may use crushed stone base course material to construct the subgrade to the bottom of the three and one-half (3-1/2) inches, five (5), eight (8) and ten (10) inch patches. The cost of furnishing, installing, and compacting the crushed stone base course material shall be considered as incidental to the items of three and one-half (3-1/2) inches, five (5), eight (8) and ten (10) inch patches.

The limits of the area to be patched shall be sawcut or milled vertically as directed by the Engineer. No concrete base course shall be removed prior to the removal of the asphalt pavement superimposed thereon without prior approval of the Engineer. All base patch limits in concrete base course shall be

saw cut full depth before the concrete is broken and removed. All costs for cutting shall be considered incidental to asphalt base patching.

Hot mix asphalt, mixture type E-1 or E-3 with nominal aggregate size of 19.0 mm or 25.0 mm, shall be placed and compacted in lifts not to exceed three and one-half (3-1/2) inches, in thickness. The Contractor shall supplement vibratory plate compaction equipment with a vibratory steel-wheeled roller utilized for compaction of the asphalt lower layer mixture in the vibrating mode. The compaction equipment shall be equipped with working water reservoirs. Recycled asphalt material may be used as patch material if the mix design is performed in accordance with Section 402.4 and the stockpile of salvaged material for recycling is approved in advance by the Engineer. The Contractor is encouraged to use approved recycled material. Only material approved in advance shall be allowed for patch material.

The Contractor shall mechanically compact the existing base course and tack the vertical edges of the patch for dust control. All costs for mechanical compaction and tack coat shall be considered incidental to the asphalt base patch. On all patches outside of the limits for resurfacing, the patch material shall be upper layer material with the last lift placed by a paving machine and considered incidental to the bid item for asphalt base patch.

Patches shall be started and completed in the same day.

Asphalt mixtures shall not be placed when the air temperature approximately three (3) feet above ground at the site of the work, in the shade and away from the effects of artificial heat, is less than 32°F.

Asphalt base patching shall be paid for at the contract unit price per square yard based on the depth of patch, which price shall be full compensation for excavation and disposal of the excavated material, preparation of the subgrade, and backfilling with hot mix asphalt for maintenance and protection of the work and for all materials, labor, tools, equipment and incidentals necessary to complete the work.

#### 403.8(b) Method of Measurement.

Asphalt base patching shall be measured per square yard based on the depth of patch.

#### 403.8(c) Basis of Payment.

The contract price for asphalt base patching as measured above shall be payment in full for the work as outlined above including excavation and disposal of the excavated material, preparation of the subgrade, and backfilling with hot mix asphalt for maintenance and protection of the work and for all materials, labor, tools, equipment and incidentals necessary to complete the work.

### **403.9 Asphalt Drive And Terrace - Resurfacing.**

#### 403.9(a) Description.

Asphalt pavement for driveways and terrace paving shall comply with Section 402.3 of the Standard Specifications.

The removals of concrete or asphalt material shall include excavation and saw cutting of the concrete and asphalt material. All material shall be hauled from the site. At no time shall any material be deposited on private property or terrace areas.

After the new asphalt pavement has been placed the excavated areas adjacent to the new pavement shall be back filled immediately with the appropriate material: topsoil, seed and mulch.

**403.9(b) Method of Measurement.**

Asphalt drive and terrace shall be measured by the area in square yards.

**403.9(c) Basis of Payment.**

The contract price for asphalt drive and terrace, measured as provided above, shall be payment in full for the work as outlined above, including: excavation, disposal of removed material, sawcutting concrete and asphalt pavement; for furnishing and placing asphalt material, finishing and protecting; fill, topsoil, seed and mulch, and for all labor, tools, equipment and incidentals necessary to complete the work.

**403.10 HMA Material For Curb Front Fill.**

**403.10(a) Description.**

The area in front of the new curb and gutter and/or inlets shall be filled full depth with approved asphalt material within two (2) inches of the new gutter edge. Existing pavement shall be sawcut as designated by the Engineer on streets that will not be milled or pulverized.

**403.10(b) Method of Measurement.**

The item of Asphalt Material for Curb Front Fill shall be measured by the lineal foot.

**403.10(c) Basis of Payment.**

The lineal footage of Asphalt Material for Curb Front Fill, measured as provided above, shall be paid for at the contract unit price bid for lineal foot which price shall be full compensation for furnishing, installing, and compacting the asphalt material, sawcutting and for all labor, tools, equipment, and incidentals necessary to complete this item of work.

**403.11 SAS Adjusting Ring.**

**403.11(a) Description.**

The Contractor shall install steel access structure adjusting rings, height shall be as directed by the Engineer, on those access structures indicated on the walk sheets or as directed by the Engineer. Each ring shall be secured with an adhesive approved by the Engineer.

**403.11(b) Method of Measurement.**

SAS adjusting ring shall be measured as units of each.

403.11(c) Basis of Payment.

The SAS adjusting ring, measured as provided above, shall be paid for at the contract unit price per each. Which price shall include full compensation for hauling, placing, finishing and protecting, and for all labor, tools, equipment and incidentals required to complete the work.

**403.12 Adjust Access Structure Casting - Resurfacing.**

403.12(a) Description.

Castings having an opening of twenty-four (24) inches or less shall be considered access structure castings. Adjusting castings shall consist of raising the frame to final grade. Castings shall be installed 1/4 inch below the final grade. Castings that are 3/4 inch, or more, below the final grade shall be repaired. The entire opening in the pavement around the access structure frame shall be sawcut where designated by the Engineer. The entire opening in the pavement around the access structure frame shall be backfilled with slurry. No disturbed or excavated material shall be used as backfill. The mix design for the slurry shall be as follows (rates are per cubic yard of slurry mix):

Water	25 gallons
Torpedo Sand	1350 pounds
3/4 Max. Aggregate	2050 pounds
Cement	50 pounds
Fly Ash (Type C)	100 pounds

Type “M” air entrained mortar shall be used for adjustment to the required elevation.

Castings shall be protected from traffic for a minimum of thirty-six (36) hours after pouring. Protection and ramping of casting with hot mix asphalt shall comply with Section 403.1.

Adjusting access structure castings includes removing the existing casting, all existing adjusting blocks and bricking to a sound brick or block base, and installing new adjusting blocks or bricking to the required elevation. New adjusting blocks and bricking shall be solid concrete.

Where designated by the Engineer, the Contractor shall remove existing castings and replace them with new frames and covers furnished by the City of Madison.

403.12(b) Method of Measurement.

Adjustment of Access Structure Casting shall be measured as units of each.

403.12(c) Basis of Payment.

The adjustment of access structure castings, measured as provided above, shall be paid for at the contract unit price per each. Which price shall include full compensation for sawcutting, removing the existing access structure casting and frame, removing all existing adjusting blocks and bricking to a sound brick or block base, installing new adjusting blocks or two (2) inch adjusting rings to the required elevation, for excavating, backfilling with slurry, for disposal of removed material, for furnishing all materials except castings and frames supplied by The City of Madison, for hauling new and existing castings, for placing, finishing, ramping for protection and for all labor, tools, equipment and incidentals required to complete the work.

### 403.13 Adjust Catchbasin Casting - Resurfacing.

#### 403.13(a) Description.

Castings having an opening with an inside dimension of over twenty-four (24) inches shall be considered catchbasin castings. Adjusting catchbasin castings shall consist of raising the frame to final grade. Castings shall be installed 1/4 inch below the final grade. Castings that are 3/4 inch, or more, below the final grade shall be repaired. The entire opening in the pavement around the access structure frame shall be sawcut where designated by the Engineer. The entire opening in the pavement around the access structure frame shall be backfilled with slurry. No disturbed or excavated material shall be used as backfill. The mix design for the slurry shall be as follows (rates are per cubic yard of slurry mix):

Water	25 gallons
Torpedo Sand	1350 pounds
3/4 Max. Aggregate	2050 pounds
Cement	50 pounds
Fly Ash (Type C)	100 pounds

Type "M" air entrained mortar shall be used for adjustment to the required elevation.

Castings shall be protected from traffic for a minimum of thirty-six (36) hours after pouring. Protection and ramping of casting with hot mix asphalt shall comply with Section 403.1.

Adjusting catchbasin castings includes removing the existing casting, all existing adjusting blocks and bricking to a sound brick or block base, and installing new adjusting blocks or bricking to the required elevation. New adjusting blocks and bricking shall be solid concrete.

Where designated by the Engineer, the Contractor shall remove existing castings and replace them with new frames and covers furnished by the City of Madison.

The finished top elevation of castings in the paved area of streets shall be set with a string line at least forty (40) feet long set over the casting parallel to the street direction at the proposed finished grade of the street.

#### 403.13(b) Method of Measurement. **METHOD OF MEASUREMENT**

Adjustment of Catchbasin Casting shall be measured as units of each.

#### 403.13(c) Basis of Payment.

The adjustment of catchbasin castings, measured as provided above, shall be paid for at the contract unit price per each. Which price shall include full compensation for sawcutting, removing the existing catchbasin casting and frame, removing all existing adjusting blocks and bricking to a sound brick or block base, installing new adjusting blocks to the required elevation, for excavating, backfilling with slurry, for disposal of removed material, for furnishing all materials except castings and frames supplied by The City of Madison, for hauling new and existing castings and frames, for placing, finishing, ramping for protection and for all labor, tools, equipment and incidentals required to complete the work.

#### **403.14 Adjust Inlet Casting, Type “H” - Resurfacing.**

##### 403.14(a) Description.

This item shall consist of adjusting the inlet castings to a new final grade. Such adjustment shall include sawcutting, removing the existing inlet casting, removing existing adjusting blocks or brick to a sound brick or block base and installing new bricks or blocks using type “M” air entrained mortar to the required elevation. New adjusting blocks and bricking shall be solid concrete. Install concrete floor. The concrete curb and gutter removed along with inlet adjustment shall be marked by the Engineer prior to removal and paid for at the unit price bid for concrete curb and gutter. The disturbed area behind the new curb and gutter shall be back filled with acceptable fill material, topsoil, seed and mulched. The disturbed area in front of the curb & gutter shall be backfilled and compacted with crushed stone. Inlet castings removed and replaced to the same grade for the Contractor’s convenience or as directed by the Engineer shall be considered as incidental to other items.

Where designated by the Engineer, the Contractor shall remove existing castings and replace them with new frames and covers furnished by the City of Madison.

##### 403.14(b) Method of Measurement.

Adjustment of type “H” inlet castings shall be measured as units of each.

##### 403.14(c) Basis of Payment.

The adjustment of inlet castings, measured as provided above, shall be paid for at the contract unit price per each. Which price shall include full compensation for sawcutting, removing the existing inlet casting, removing the existing adjusting blocks or bricks, installing concrete floor, new bricks or blocks and inlet casting to the required elevations; for excavating; for disposal of removed material; for furnishing all materials except castings and frames supplied by The City of Madison, for hauling new and existing castings and frames; for backfill, topsoil, seed and mulch; for placing, finishing and protecting; and for all labor, tools, equipment and incidentals necessary to complete the work.

#### **403.15 Adjust Inlet Casting, “Tub” Type - Resurfacing.**

##### 403.15(a) Description.

This item shall consist of sawcutting and removing the existing tub inlet casting, removing existing adjusting blocks, bricks or loose concrete to a sound concrete base. Install a concrete floor and a new “H” inlet casting to grade using such adjustments as; field pour walls, pre-cast box, or adjustment rings with a maximum of 4”(inches) of adjustment rings. Adjustments shall be made using type “M” air entrained mortar to the required elevation. The concrete curb and gutter removed along with the inlet adjustment shall be marked by the Engineer prior to removal and paid for at the unit price bid for curb and gutter. The disturbed area behind the new curb and gutter shall be back filled with acceptable fill material, topsoil, seeded and mulched. The disturbed area in front of the curb & gutter shall be backfilled and compacted with crushed stone. Inlet castings removed and replaced to the same grade for the Contractor’s convenience or as directed by the Engineer shall be considered as incidental to other items.

Where designated by the Engineer, the Contractor shall remove existing castings and replace them with new frames and covers furnished by the City of Madison.

403.15(b) Method of Measurement.

Adjustment of “tub” type inlet castings shall be measured as units of each.

403.15(c) Basis of Payment.

The adjustment of “tub” type inlet castings, measured as provided above, shall be paid for at the contract unit price per each. Which price shall include full compensation for sawcutting, removing the existing inlet casting, removing the existing adjusting blocks or bricks, installing concrete floor, new bricks or blocks and inlet casting to the required elevations; for excavating; for backfilling and compacting; topsoil, seed and mulch; for disposal of removed material; for furnishing all materials except castings and frames supplied by The City of Madison, for hauling new and existing castings and frames; for backfill, topsoil, seed and mulch; for placing, finishing and protecting; and for all labor, tools, equipment and incidentals necessary to complete the work.

**403.16 Adjust Valve Casting, Method #1 - Resurfacing, Adjust Valve Casting, Method #2 - Resurfacing, Install Adjustable Water Box, Method #3 - Resurfacing**

403.16(a) Description.

The Contractor shall adjust water or gas valve castings to final grade by the following three methods as directed by the Engineer:

The Contractor shall install screw type adjusting valve castings at locations designated by the Engineer. The screw type adjusting valve castings will be provided by the City of Madison Water Utility.

If required, ramping valve castings with HMA shall be incidental to this bid item.

Adjust Valve Casting, Method #1

Valve casting adjustment shall consist of loosening the existing casting. The casting shall be set to proper grade by turning the top casting. If asphalt material is removed it shall be a minimum of 1’ on either side of the casting and replaced with approved asphalt material compacted in place.

If the existing casting has been set in concrete the Contractor shall be paid one additional unit price bid for Adjust Valve Casting, Method #1. This work shall consist of removing the existing concrete to a sound base and back filling and compacting 1-1/2” crushed stone, level with the bottom of the existing asphalt, then ramping with compacted asphalt material.

When the Engineer directs the Contractor to replace or add a casting extension and the depth of excavation necessary to do this work exceeds 24” inches, the Contractor shall be paid one additional unit price bid for Adjust Valve Casting, Method # 1. The area that is excavated shall be back filled and compacted with 1-1/2” crushed stone. This does not apply to replacing a casting top or lid. Any disturbed or excavated material shall not be used as back fill.



### Adjust Valve Casting, Method #2

Adjusting monument castings and valve castings, when directed by the Engineer shall consist of raising the castings to final grade. The entire opening around the monument casting or valve casting shall be back filled with a slurry mix and shall be protected from traffic for a minimum of thirty-six (36) hours after pouring. The casting shall be ramped with asphalt material. Any disturbed or excavated material shall not be used as back fill.

The mix design for the slurry shall be as follows (rates are per cubic yard of slurry mix):

Water	25 gallons
Torpedo Sand	1350 pounds
3/4 Max. Aggregate	2050 pounds
Cement	50 pounds
Fly Ash (Type C)	100 pounds

Type "M" air entrained mortar shall be used for adjustment to the required elevation.

### Install Adjustable Valve Water Box, Method #3

The contractor shall install screw type, height adjustable, cast iron valve box risers furnished by the city.

City furnished adjustable valve box riser shall be model number VB2667, VB2668, VB2669, or VB 2670 as manufactured by Sigma Corporation or approved equal. Casting shall be produced from gray cast iron to ASTM Class 25 standards.

Installation shall consist of removing valve box cover, removing debris from threaded valve box top casting, threading adjustable valve box riser into top casting and setting to specified grade, replacing valve box cover.

#### 403.16(b) Method of Measurement.

Adjustment of valve castings shall be measured as units of each as completed according to Method #1, Method #2 or Install Adjustable Valve Water Box as directed by the Engineer.

#### 403.16(c) Basis of Payment.

The adjustment of valve castings, measured as provided above, shall be paid for at the contract unit price per each. Which price shall include full compensation for loosing casting, removing asphalt or concrete material, setting casting to grade, backfilling and compacting with crushed stone, adding an extension, backfilling with a slurry mix, ramping casting with asphalt material and protection of casting as described in Method #1, Method #2 or Install Adjustable Valve Water Box for furnishing all labor, tools, material, equipment and incidentals necessary to complete the work.

### **403.17 Adjust Monument Casting - Resurfacing.**

Adjusting monument castings shall consist of raising monument castings to final grade. The entire opening around the monument casting shall be backfilled with high-early-strength concrete and shall

be protected from traffic for a minimum of thirty-six (36) hours after pouring. No disturbed or excavated material shall be used as backfill.

All monument castings shall be adjusted and paid for as adjust valve castings per Section 403.16.

#### **403.18 Adjust Private Utility Castings - Resurfacing.**

The Contractor may be required to adjust private utility castings with this contract. If the private utility wishes to replace any existing castings with new frames and lids, the private utility will deliver the new castings to the job site.

Any modifications of the structure will not be included with this contract. If the private utilities chooses to modify any of their structures, the modification will be done by others or by direct agreement between the Contractor and the private utility. All modifications to private utility structures for the private utility will be at no cost to the City and with no additional work days added to the contract completion date.

The procedures for adjustment of private utility castings and the method of payment for the work shall be as specified above for sewer access structure castings (403.12) and valve castings (403.16).

#### **403.19 Rebuild Inlet - Resurfacing.**

403.19(a) Description.

This item shall include sawcutting and removal of the old inlet, “tub” type or type “H”, and constructing a new “H” inlet when required. Locations for this item shall be marked by the Engineer prior to removal. It is anticipated that all of these inlets will require pouring the inlet box and floor in place according to the standard detail drawing 5.7.11. Reconnection of leads shall be considered incidental to “Rebuild Inlet” and shall include repair of leads damaged from inlet removal. Rebuilds using pre-cast will be made at the discretion of the Engineer. Casting shall be placed to final grade using type “M” below grade mortar mix and air-entrained additives shall be considered incidental to this item. Any “HH” inlet rebuild shall be paid as one additional unit price bid for Rebuild Inlet.

The concrete curb and gutter removed along with inlet rebuild shall be marked by the Engineer prior to removal, and paid for at the unit price bid for concrete curb and gutter. The disturbed area behind the new curb and gutter, including inlet, shall be back filled with acceptable fill material, topsoil, seed and mulched. Disturbed area in front of the curb & gutter shall be backfilled and compacted with crushed stone

Any inlets abandoned shall be paid as Rebuild Inlet - Resurfacing and include removal of inlet, removal of any necessary pipe, sealing the resulting hole or opening, and back filling and compacting excavated area.

403.19(b) Method of Measurement.**METHOD OF MEASUREMENT**

Rebuild Inlet shall be measured as units of each.

403.19(c) Basis of Payment.

Rebuild inlet measured as provided above shall be paid for at the contract price per each, which price shall be full compensation for sawcutting, removal of old casting; installing pre-cast or poured in place inlet box and floor; reconnecting leads; repair of damaged leads; adjustment of existing or City furnished casting; pipe removal; pipe plug; disposal of material; backfill and compaction; topsoil; seed; mulch; furnishing all materials; placing; finishing; protecting and for all labor, tools, equipment and incidentals required to complete the work.

**403.20 Rebuild Access Structure Top - Resurfacing.**

403.20(a) Description.

Rebuilding access structure tops shall consist of sawcutting, removing existing deteriorated access structure, catchbasin or inlet tops and replacing them with precast or cast-in-place top sections. The casting shall be installed to final grade and no payment will be made for casting adjustments. The entire opening in the pavement around the access structure or catchbasin top shall be backfilled with slurry.

If required, ramping valve castings with HMA shall be incidental to this bid item.

The mix design for the slurry shall be as follows (rates are per cubic yard of slurry mix):

Water	25 gallons
Torpedo Sand	1350 pounds
3/4 Max. Aggregate	2050 pounds
Cement	50 pounds
Fly Ash (Type C)	100 pounds

The structure shall be protected from traffic for a minimum of three (3) days after pouring. No disturbed or excavated material shall be used as backfill. The Contractor shall furnish any precast sections used to rebuild access structure or catchbasin tops. New castings, if needed, will be furnished by the City the same as above.

403.20(b) Method of Measurement.

Rebuild sewer access structure top shall be measured as units of each.

403.20(c) Basis of Payment.

Rebuild sewer access structure top, measured as provided above shall be paid for at the contract price per each, which price shall be full compensation for sawcutting, removing the existing top, including casting; for installing new pre-cast or poured in place top; for adjusting existing or city furnished casting; for backfilling with slurry; for disposal of material; for furnishing all material; for placing, finishing and protecting; and for all labor, tools, equipment and incidentals necessary to complete the work

**403.21 Remove and Replace Concrete Curb & Gutter, Machine Placed - Resurfacing; Remove and Replace Concrete Curb & Gutter, Hand Placed – Resurfacing.**

403.21(a) Description.

Concrete curb and gutter shall consist of removing and replacing existing concrete curb and gutter where designated by the Engineer in accordance with The City of Madison Standard Specifications Section 302 except as modified herein.

When a portion of curb and gutter to be replaced contains an inlet, the cost of adjusting the inlet, if for the convenience of the contractor, in its same location shall be included in the unit price bid of remove and replace concrete curb and gutter.

Removal and replacement of concrete curb and gutter shall include excavating, replacement of disturbed sub-base material with four (4") of 3/4" crushed stone or crushed concrete, grade preparation, tree root removal, expansion joints and disposal. If directed by the Engineer, "Type X" curb will be required at various locations at no additional cost. All work done in the vicinity of any tree located in the terrace shall be completed in accordance with section 107.13 Tree Protection Specification.

The Contractor shall place all curb & gutter with the use of a slip form paver as directed by the Engineer except where obstructions prevent the uses of a machine. Obstructions shall include but not be limited to: inlets; sidewalk; castings and trees.

Removal of concrete curb and gutter shall include excavation of existing material including asphalt material, up to one (1) foot on each side of the curb and gutter, as the case may be. All material shall be hauled from the site. At no time shall any material be deposited on private property or terrace areas. All work done in the vicinity of any tree located in the terrace shall be completed in accordance with section 107.13 Tree Protection Specification.

Existing concrete, asphalt mixes or other types of material used to shim raised curb & gutter shall be removed from adjacent curb & gutter stones prior to placing new curb & gutter.

After the new curb and gutter has been constructed and the forms removed, the excavated areas adjacent to the curb and gutter shall be back filled immediately with the appropriate material; topsoil, crushed stone, concrete or asphalt mix.

All debris shall be removed from the excavated areas prior to placement of the topsoil.

Transverse full depth saw cuts shall be placed where directed by the Engineer.

Transverse full depth sawcuts shall be incidental.

The Contractor shall construct the curb cuts using a "profile curb cut" with the curb head removed by using a machine type concrete saw specifically designed for this type of work. The curb shall be cut off flush with the flow line through the ramp. Profile curb cut shall be paid under **BID ITEM 30330 - PROFILE CURB CUT.**

The Contractor shall take precautions during construction operations not to disfigure, scar, or impair the health of any tree on public or private property.

The Contractor shall remove tree roots from existing live trees in accordance with section 107.13 Tree Protection Specification.

Tree roots ends one-half inch (1/2") and up which are severed shall be cut in accordance with section 107.13 Tree Protection Specification. The tree root ends shall be back filled with soil or other suitable means immediately following the cutting.

#### 403.21(b) Method of Measurement.

Concrete Curb and Gutter shall be measured by length in lineal feet in accordance with Subsection 302.3(a) of The City of Madison Standard Specifications.

#### 403.21(c) Basis of Payment.

The contract unit price shall be paid as per Subsection 302.2(b) of The City of Madison Standard Specifications except that the unit price shall include removal for curb and gutter, excavating, sawcut, gravel, fill, topsoil, seed and matting. Curb & Gutter placed with a slip form paver shall be paid under **BID ITEM 40381 – REMOVE EXISTING CONCRETE CURB & GUTTER AND CONSTRUCT CONCRETE CURB & GUTTER, MACHINE PLACED - RESURFACING**. Curb & Gutter placed by hand shall be paid under **BID ITEM 40382 – REMOVE EXISTING CONCRETE CURB & GUTTER AND CONSTRUCT CONCRETE CURB & GUTTER, HAND PLACED - RESURFACING**.

### **403.22 Remove and Replace 5 Inch Concrete Sidewalk – Resurfacing; Remove and Replace 7 Inch Concrete Sidewalk and Drive – Resurfacing.**

#### 403.22(a) Description.

Concrete walk and drive apron shall consist of removing and replacing existing walk and drive apron where designated by the Engineer in accordance with Section 303 of The City of Madison Standard Specifications except as modified herein.

Removal and replacement of sidewalk and drive aprons shall include all costs for excavating, replacement of disturbed sub-base material with four (4") of 3/4" crushed stone or crushed concrete, grade preparation, tree root removal, expansion joints and disposal

Removal of sidewalks and drive aprons shall include excavation of existing material including asphalt material, up to one (1) foot on each side of the sidewalk or drive aprons, as the case may be. All material shall be hauled from the site. At no time shall any material be deposited on private property or terrace areas.

Existing concrete, asphalt mixes or other types of material used to shim raised sidewalks shall be removed from adjacent sidewalk stones prior to placing new sidewalk.

After the new sidewalks have been constructed and the forms removed, the excavated areas adjacent to the sidewalk shall be back filled immediately with the appropriate material; topsoil, crushed stone, concrete or asphalt mix.

All debris shall be removed from the excavated areas prior to placement of the topsoil.

Transverse full depth saw cuts shall be placed where directed by the Engineer.

Transverse full depth sawcuts shall be incidental.

The Contractor shall take precautions during construction operations not to disfigure, scar, or impair the health of any tree on public or private property.

The Contractor shall remove tree roots from existing live trees in accordance with section 107.13 Tree Protection Specification.

Tree roots ends one-half inch (1/2") and up which are severed shall be cut in accordance with section 107.13 Tree Protection Specification. The tree root ends shall be back filled with soil or other suitable means immediately following the cutting.

#### 403.22(b) Method of Measurement.

Concrete sidewalk shall be measured by the Square Foot.

#### 403.22(c) Basis of Payment.

The contract unit price shall be paid as per Subsection 303.3(b) of The City of Madison Standard Specifications except that the unit price shall include: removal of sidewalk or drive apron; excavating; fill; gravel, topsoil; seed and matting.

### **403.23 Crushed Stone - Resurfacing.**

Crushed stone shall consist of furnishing and placing crushed stone base course according to Article 401 of these Specifications. Where designated by the Engineer, the Contractor shall undercut the base patch area and backfill to the depth of the asphalt base patch with crushed stone. All costs for undercutting and furnishing, placing and compacting the crushed stone shall be considered incidental to crushed stone.

### **403.24 Remove Asphalt Surface - Resurfacing.**

Remove asphalt surface shall consist of removing existing asphalt pavement from a concrete base by any means including, but not limited to, grinders, air compressors, hand picks, motor blades, end loaders, back hoes, etc.

### **403.25 Remove Concrete Utility Patch**

#### 403.25(a) Description.

The contractor shall remove concrete utility patches in accordance with Section 203.2 of The City of Madison Standard Specifications. This item is intended for the removal of concrete utility patches in excess of sixty (60) continuous lineal feet on streets scheduled for pulverizing. Concrete utility patches less than sixty (60) continuous lineal shall be considered incidental to **BID ITEM 40311 - PULVERIZE AND SHAPE.**

403.25(b) Method of Measurement

Remove concrete utility patch shall be measured by the unit of lineal feet along the centerline of the utility patch.

403.25(c) Basis of Payment

Remove concrete utility patch measured as provided above shall be paid for at the contract unit price per lineal foot in accordance with Section 203.4 of City of Madison Standard Specifications.

## **ARTICLE 404 - CONCRETE PAVEMENT**

---

### **404.1 General.**

The installation of concrete pavement, including materials, equipment, foundation, construction methods, method of measurement, and basis of payment shall be in accordance with Article 415 and 416, "Concrete Pavement", of the latest edition of the Standard Specifications for Highway and Structure Construction of the State of Wisconsin, Department of Transportation, except as modified herein The City of Madison Standard Specifications or the Special Provisions of the contract.

### **404.2 Forms.**

#### **404.2(a) Flexible Forms.**

When concrete pavement is constructed on a curve, flexible forms shall be used for all curves having a radius of two hundred (200) feet or less, unless otherwise directed by the Engineer.

#### **404.2(b) Wood Forms.**

Wood forms shall only be allowed when approved by the Engineer.

### **404.3 Steel Pins.**

The Contractor shall furnish steel pins to use in setting grades for concrete pavement.

### **404.4 Concrete Speed Hump.**

#### **404.4(a) Description.**

The work under this item shall consist of manually forming and pouring concrete speed humps in accordance as detailed in the plans. All dowel bars shall be epoxy coated and in accordance with Standard Details 3.10 and 3.11 of the Standard Specifications. All concrete curb and gutter adjacent to the speed hump shall be paid for separately under that associated bid item. Positive drainage shall be maintained in the flowline of all curb and gutter adjacent to the speed humps. Dowelling of curb and gutter for speed hump installation shall be considered incidental to Concrete Speed Hump.

#### **404.4(b) Method of Construction.**

Concrete Speed Hump shall be constructed at the location and to the dimensions as shown in the plans. The speed humps shall be poured in sections in order to maintain traffic flow. The concrete speed humps shall comply with all applicable sections "Section 415 Concrete Pavement" of the Wisconsin Department of Transportation Standard Specifications for Road and Bridge Construction, latest Edition, pertaining to Non-Reinforced Concrete Pavement, Doweled. Concrete Speed humps shall be doweled with epoxy coated dowels as shown on the detail drawing. It is anticipated that the speed humps will be hand formed and no additional compensation shall be given for any labor required to form the speed humps to the dimensions shown on the details.

The installation of Concrete Speed Hump, as described above and as detailed in the plans, will be measured in place by the square yard for completed and accepted work.



#### 404.4(c) Method of Measurement.

Concrete Speed Hump shall be measured by the square yard in place.

This item, measured as provided above, will be paid for at the contract price per square yard of speed hump installed and for furnishing all labor, tools, materials, reinforcing, equipment, and incidentals necessary to complete the work.

#### 404.4(d) Basis of Payment.

This item, measured as provided above, will be paid for at the contract price per square yard of speed hump installed and for furnishing all labor, tools, materials, reinforcing, equipment, and incidentals necessary to complete the work.

### **404.5 Concrete Pavement Reconstruction.**

#### 404.5(a) Concrete Pavement Removal.

The size of the area to be removed shall be designated in the field by the Engineer. Removal of the concrete slab shall be accomplished by a lifting device. Full depth sawcuts shall be made with a diamond blade using a two phase sawing operation. The longitudinal sides of the patch shall also be sawed to provide for the lifting removal, whether this is full depth, or just deep enough to insure that the tie bars are severed. The use of the lifting device is intended to preclude any disturbance of the underlying base course and reduce spalling of the edges of the concrete remaining in place. The lifting operation shall follow the sawcutting as closely as practicable. Other methods of removing the pavement which will not disturb the base course or the adjacent edges may be used only if approved by the Engineer. Refer to Standard Detail Drawing 5.2.3 for additional requirements.

If the concrete adjacent to the lifted patch is damaged during the course of removal, hole drilling or replacement, the damaged area shall be repaired by removing the damaged area. A full depth sawcut will be required. Such repair of concrete damaged during the course of Concrete Pavement Reconstruction shall be considered incidental to that item of work, and no separate compensation shall be made.

Following the removal of the concrete pavement the area shall be cleaned with hand tools. Any disturbed base course shall be removed and poured back with additional depth of concrete.

#### 404.5(b) Placement of Concrete Pavement.

Joints in the replaced section of concrete shall be doweled in accordance with the details on Standard Plate 3.11. Epoxy coated tie bars shall be installed to a tight driven fit and secured with an approved epoxy grout. The free end of the Epoxy coated dowel bars shall be coated with an approved bond breaker.

Concrete patches shall be installed per Standard Detail Drawing 5.2.3

When only one lane is to be patched, a bond breaker consisting of 1/8" thick felt shall be installed along the longitudinal joint of the patch between adjacent lanes of concrete in lieu of the #4 tie bars.

The concrete design mix shall be such that the concrete achieves a strength of at least 3,000 psi in forty-eight (48) hours. The concrete design mix shall be submitted to the Engineer for approval prior to pouring of concrete.

The opening of patches to traffic shall be controlled by cylinder tests, and shall be no earlier than forty-eight (48) hours.

The strike-off and consolidation shall conform to Section 416.3.9.4 of the latest edition of the Standard Specifications for Highway and Structure Construction of the State of Wisconsin, Department of Transportation. The concrete shall be consolidated in place by use of an immersion type vibrator or vibratory screed. The screed or template used for the surface strike-off shall be of an approved design constructed of metal, or with a metal edge, and sufficiently rigid to retain its shape.

The transverse edges of the finished patch shall be flush with the edges of the existing concrete pavement. The longitudinal surface shall form a straight line from edge to edge within a tolerance of +1/8 inch. Pavement patches not meeting the 1/8" tolerance allowance shall be removed and replaced immediately.

The final surface of the pavement shall have a burlap drag or broom finish.

Whenever possible, the concrete shall be placed on the same day that the old pavement is removed.

The Contractor shall re-seed any terraces or medians damaged or disturbed during construction. This item shall be considered incidental to the items of work involved.

In the event that it is necessary to leave an open pavement section at the end of the day's work, one Class III barricade shall be placed in front of the open hole.

Construction equipment and materials are not to be stored within the street right-of-way during non-working hours.

#### 404.5(c) Method of Measurement.

Concrete Pavement Reconstruction shall be measured by the square yard in place.

#### 404.5(d) Basis of Payment.

Concrete Pavement Reconstruction shall be paid for at the contract unit price per square yard which price shall be payment in full for full-depth sawcutting, removal and disposal of the existing pavement, placing, finishing and curing the concrete for furnishing and installing the #10 epoxy coated dowel bars and epoxy coated deformed #6 bars and the #4 epoxy coated tie bars in the longitudinal joints, or 1/8" felt bond breaker, for furnishing all barricading, labor, materials, equipment, tools, and incidentals necessary to complete the work.

All costs for maintaining traffic and traffic control shall be at the expense of the Contractor.

## **ARTICLE 405 - INFRARED SEAMLESS PATCHING**

---

### **405.1 General.**

This Work shall consist of furnishing all materials, equipment and labor necessary to the application of Infrared Seamless Patching. Infrared Thermal Bond Seamless Asphalt Pavement Patching is a method of blending new asphalt concrete material with infrared heated existing surface material to form a joint free integral mix patch.

### **405.2 Personnel.**

The Contractor's personnel shall be experienced in Infrared Seamless Patching work and shall be knowledgeable regarding the material and equipment to be used for Infrared Seamless Patching.

### **405.3 Materials.**

New asphalt concrete material for patching shall be equal to the City of Madison Standard Specification for HMA type E-1, 12.5 mm mix design.

A minimum of 20% of new virgin material shall be added to all patched areas. Additional material shall be added as needed and as directed by the Engineer.

### **405.4 Equipment.**

Pavement Restoration Vehicle (PVR) shall be a truck or trailer mounted, self contained pavement maintenance heating system equipped with a fuel system and heated chamber capable of maintaining the fresh virgin asphalt materials at a temperature of 275°F or higher. Any material with a laying temperature less than 265°F shall be discarded.

The adjustable height infrared heating unit may be a truck or trailer mounted to the PRV. The heating unit shall be equipped with a heating chamber or chambers capable of heating the existing asphalt pavement to a workable condition without oxidation or burning. There shall be no flames in direct contact with the existing asphalt surface.

Compaction shall be achieved with a self-propelled vibratory roller of sufficient size to provide complete compaction to the full heated depth of the patched area. The new surface shall match the elevation of the adjacent pavement. Compaction methods shall be subject to the approval of the Engineer.

### **405.5 Preparation and Installation.**

Potholes, alligator cracks or other surface defects that are contiguous with cracks are considered to be crack related and are to be repaired by Infrared Seamless Patching. Each street segment labeled with an (Infra) on the proposal pages shall be patched using the infrared seamless patching method. If there are question about where to patch the streets, consult the Engineer.

The area to be patched shall be determined in the field by the Contractor and verified by the Engineer. The Contractor shall determine the starting point of the work and the sequence of the heater application so as to accomplish all the work as specified.

The infrared heating unit shall be lowered to within six (6") inches of the existing pavement. The heated area must extend at least six (6") inches outside the area of repair.

Apply heat continuously until the surface is heated to a depth of at least two (2") inches. When the heated surface can be worked with a rake, proper heat penetration has been achieved.

Remove enough existing asphalt material (as required by adjacent grades) to allow for the addition of 20% new virgin asphalt mix to achieve a blend of 20% new to 80% existing heated material within the area of the patch.

If the patch area is already low, less existing material need be removed prior to the addition of the new virgin mix. Remove only the old oxidized surface in the low areas.

Reshape the patched area by hand with a rake and lute to match the grade of the adjacent pavement.

Compact patched areas with the specified roller to the full depth of the heated patch. The compacted surface shall be smooth, in texture and shall have positive drainage, matching the slope of existing pavement.

The site shall be cleaned after paving. Remove all debris resulting from the patching operation to the satisfaction of the Engineer.

#### **405.6 Method of Measurement.**

Infrared Seamless Patching shall be measured by the square foot.

#### **405.7 Basis of Payment.**

Infrared Seamless Patching shall be paid for at the Contractors bid price which price shall be full compensation for furnishing; heating, unloading, hauling, infrared patching; and for all labor, tools, equipment, and incidental necessary to complete the work as provided in the contract.

## **ARTICLE 406 - PAVEMENT CRACK SEALING**

---

### **406.1 Materials For Pavement Crack Sealing.**

Crack sealing materials shall be a high performance specification petroleum based polymeric hot pour sealant. The sealant shall meet the requirements of ASTM D3405 or approved equal. Each batch of cracked filling materials delivered to the job site shall be accompanied by the manufacturer's certification stating that the material meets the requirements of the specification.

In order to conserve material in large cracks, the Contractor may insert a closed cell backer rod material or other material approved by the Engineer.

### **406.2 Preparation of the Crack Sealing Mixtures.**

The Contractor shall deliver to the Engineer the manufacturer's literature and instructions dealing with the preparation and installation of the crack sealing material to be installed. The preparation, handling, and installation and clean up of the crack sealing materials shall be in accordance with the manufacturer's specifications. It shall be the Contractor's responsibility to remove and dispose of all containers used to transport the crack sealing mixture.

### **406.3 Installation of Crack Sealing.**

#### **406.3(a) General.**

This work consists of routing, cleaning, street sweeping, preparing and filling pavement cracks 1/8" or wider in existing bituminous pavements. The Contractor shall provide a petroleum based crack sealant in accordance with the specifications for the work. Following these Special Provisions is a list of those streets proposed for crack sealing as a part of this contract. The Contractor will not be required to seal the existing edge of gutter joint unless specified in the list of street segments.

#### **406.3(b) Personnel.**

The Contractor's personnel shall be experienced in crack sealing work and shall be knowledgeable regarding the material and equipment to be used for crack sealing.

#### **405.3(c) Equipment.**

The Contractor shall furnish all equipment necessary to complete the routing, cleaning, street sweeping, preparing and sealing of cracks promptly and in accordance with the requirements specified. The equipment required for this operation shall include but not limited to:

1. High pressure air equipment capable of developing 100 lbs. per square inch air pressure and capable of blowing sand and other foreign material from the crack.
2. Air chisel or hand tools, which can remove loose or spalled material adjacent to the cracks.
3. A pressure distributor for applying the crack sealing material in accordance with the manufacturer's instructions.
4. Hot air lance to remove moisture.

#### 406.3(d) Preparation of the Cracks.

The cracks shall be routed to a minimum width of 3/4 inch (1 inch maximum) and a minimum depth of 3/4 inch (1 inch maximum).

In those instances of cracks which have been previously sealed and for which the sealant has failed, the Contractor shall remove the sealant from the crack.

The crack shall be cleaned using high pressured air equipment and broken or spalled material which is unable to be removed by high pressured air shall be removed using an air chisel or hand tool. All vegetation and loose material shall be removed from the cracks.

The contractor shall be responsible for all street sweeping and removal of debris. All crack sealed streets (including sidewalks and driveways) shall be swept clean of all debris created from the routing of cracks within twenty-four (24) hours of being sealed.

In wide cracks, the Contractor may insert a closed cell backer rod material, or other material approved by the Engineer in the bottom of the crack in order to reduce the amount of seal material required. However, the Engineer may require depth of sealant equal to 1.5 times the width of the crack.

#### 406.3(e) Installation of Sealant.

Crack sealant shall be prepared and applied per the manufacturer's recommendation. Immediately prior to filling, the crack shall be cleared of all loose material, dirt and vegetation with compressed air at a minimum pressure of 100 lbs. per square inch (psi). Debris is to be blown out in a manor so that the fresh sealant is not contaminated. The cracks shall be dry prior to filling. The Contractor may either allow the crack to dry by the air or through the use of a hot air lance.

A sealant overband of 1 to 2-inch wide is required on each side of the routed crack with a maximum of 1/8-inch thickness. At locations where the overband exceeds these limits the Contractor will be required to remove the sealant and replace it at their own expense.

At locations where the crack sealant settles in the crack opening more than 1/4" below the pavement surface, the Contractor will remove the sealant and replace it at their own expense.

The Contractor shall not allow traffic on the road until the sealant has properly set up and no danger of damage to sealant exists. The Contractor shall use traffic barriers or flagmen to prevent the tracking of uncured material. The Contractor may dust the newly sealed cracks with sand or other approved material when a proper cure time on the sealant is not attainable.

#### **406.4 Method of Measurement.**

Bid Item 40601 - Pavement Crack Sealing shall be measured per street segment installed. Each segment shall be considered as a lump sum unit.

Bid Item 40602 - Pavement crack Sealing shall be measured by the lineal foot installed.

#### **406.5 Basis of Payment.**

Crack sealing shall be paid for at the Contractors bid price. Which price shall be full compensation for furnishing; unloading, hauling, and for applying the crack sealing material; for the routing, cleaning of the cracks, street sweeping; for the filling of any wide cracks with a closed cell fill material, and for all labor, tools, equipment, and incidental necessary to complete the work as provided in the contract.

## **ARTICLE 407 - SPRAY PATCHING**

---

### **407.1 General.**

The work shall consist of repairing transverse and longitudinal cracks, alligator cracks, or potholes that cannot be repaired by crack sealing. The Contractor shall clean the area to be spray patched of all rock, dirt, sand, vegetation or other objectionable material, apply a tack material, fill the void with oil coated chips or other approved material and compact the mix if deemed necessary by the Engineer.

### **407.2 Personnel.**

The Contractor's personnel shall be experienced in spray patching work and shall be knowledgeable regarding the material and equipment to be used for spray patching.

### **407.3 Equipment.**

The Contractor shall supply all equipment necessary to complete the work. The equipment required includes but is not limited to the following:

1. High pressure air equipment capable of developing 100 lbs. per square inch air pressure and capable of blowing sand and other foreign material from the crack.
2. A proprietary or prototype machine capable of spraying the tack and spray patching material into the cracks or potholes.
3. Appropriate compaction equipment, if deemed necessary by the Engineer.

### **407.4 Preparation and Installation of Spray Patching.**

Potholes, alligator cracks or other surface defects that are contiguous with cracks are considered to be 'crack related' and are to be repaired by spray patching. Each street segment labeled with an (SP) on the proposal pages shall be spray patched. If there is questions about where to spray patch the streets, consult the Engineer. There may be street segments, which are not labeled (SP), but shall be spray patched at the discretion of the Engineer.

Work shall not be preformed when the atmospheric temperature is below 36°Fahrenheit.

All objectionable material shall be removed from the open crack and surrounding area by blowing with high pressure air streams or other means acceptable by the Engineer.

Cleaned cracks shall be sprayed with the emulsified asphalt, or tack coat and sprayed with the approved patching material.

Some over-spraying of the crack will be required to ensure a smooth transition between the repaired areas and the adjacent undisturbed pavement surface.

The repaired area shall be compacted, if necessary, to ensure adequate embedment of the patch mixture into and over the repaired area.



All loose aggregate and debris shall be swept or removed from the pavement surface and disposed of, to the satisfaction of the Engineer, prior to spray patching.

**407.5 Method of Measurement.**

Spray Patching shall be measured by the square foot installed.

**407.6 Basis of Payment.**

Spray Patching shall be paid for at the Contractor's bid price. Which price shall be full compensation for furnishing; unloading, hauling, and for applying the spray patching and for all labor, tools, equipment, and incidental necessary to complete the work as provided in the contract.

## **ARTICLE 408 - PAVEMENT CHIP SEAL**

---

### **408.1 Materials For Pavement Chip Sealing.**

The aggregate for the Chip Seal shall consist of hard and durable Black Boiler Slag (by-product of coal). The gradation for the material shall conform to the following requirements:

<b>SIEVE SIZE</b>	<b>PERCENT PASSING BY WEIGHT</b>
3/8 inch	100
No. 4	90-100
No. 8	45-75
No. 40	0-8
No. 200	0-3

Chip Sealing and Seal Coat are considered to be one and the same for these special provisions. The Chip Seal shall conform to Section 475 "Seal Coat" of the "Standard Specifications for Highway and Structure Construction" 2003 Edition prepared by the State of Wisconsin Department of Transportation and these special provisions herein set forth shall govern this construction.

The asphaltic material for the Chip Seal shall be CRS-2P, Polymer modified, and be applied at a rate of 0.28 gallons per square yard. This asphaltic material shall be rapid set emulsion that has elastic properties and shall comply with AASHTO M316.

The temperature of the Asphaltic Emulsion at the time of application shall not be less than 150 degrees Fahrenheit nor more than 180 degrees Fahrenheit.

The aggregate for the Chip Seal shall consist of hard and durable particles of Black Boiler Slag (by-product of coal). The Gradation for the material shall conform to the following requirements:

The Contractor will be required to supply a sample to the Engineer prior to the start of work. The Contractor shall also submit written verification from their Supplier that the asphalt emulsion and aggregate properly bond. Should there be any discrepancies in the field, the Contractor shall be responsible for all costs associated with repairs. The application rates for the screenings and Asphaltic Emulsion shall be within the range specified in the following table.

<b>SCREENINGS</b>	<b>LB/S.Y.</b>	<b>ASPHALTIC EMULSION (GAL. /S.Y.)</b>
Single Chip Seal	18 TO 22	0.28-0.32

### **408.2 Personnel**

The Contractor's personnel shall be experienced in Chip Sealing work and shall be knowledgeable regarding the material and equipment to be used for Chip Sealing.

### **408.3 Equipment**

The Contractor shall furnish all equipment necessary, but not be limited to the equipment specified in Section 475.3.2 of the WISDOT Standard Specifications.

The second paragraph of the WISDOT Standard Specifications, Section 475.3.5 “Applying and Rolling Seal Coat Aggregate” is amended to read as follows:

The Contractor shall furnish a minimum of two (2) pneumatic-tired rollers.

The initial rolling shall consist of one (1) complete coverage performed with a pneumatic-tired roller and shall begin immediately behind the spreader. Binder and screenings shall not be spread more than 500 feet ahead of completion of the initial rolling operations. Secondary rolling shall begin immediately after completion of the initial rolling. The amount of secondary rolling shall be sufficient to adequately seat the screenings and in no case shall be less than two (2) complete coverages.

The Contractor shall sweep the completed Chip Sealed streets within FORTY-EIGHT (48) hours after the second rolling or after the Chip Sealing is set whichever is sooner. The Contractor shall be required to sweep the streets to remove ALL loose aggregate left from the Chip Sealing application. This may require more than one sweeping.

#### **408.4 Preparation of the Surface and Protection**

Immediately before applying the Asphaltic Emulsion, the Contractor shall be responsible for removing all loose material, silt, clay, vegetation in the street and edge of gutter and other objectionable materials from the street with a power broom, street sweeper, edger or other approved method.

Prior to Chip Sealing the Contractor shall protect all inlets contained within the Chip Sealing area and downstream inlets in accordance with standard Detail Drawing 1.04 in the City of Madison’s Standard Specifications.

It shall be the Contractors responsibility to locate and protect all utility castings including but not limited to sewer access structures, water valves, inlets, and catch basins within the street or streets to be chip sealed prior to starting work and protect these castings so that **ABSOLUTELY NO ASPHALTIC EMULSION** will be applied. If castings are covered by chip sealing the Contractor will be responsible to clean and or replace the all the castings at their own expense, as required by the City Engineer. No work shall begin until all utility castings are protected. No work shall begin until all Traffic Control is in place as required in Section 107.7.

**All inlet protection shall remain in place until the streets are swept to the satisfaction of the Engineer. Please note that BID ITEM 21041 INLET PROTECTION TYPE D – COMPLETE is undistributed and may or may not be used. All other inlet protection is considered incidental to lump sum bid of chip sealing.**

#### **408.5 Method of Measurement**

The Contractor shall bid each Street segment in the contract individually; based on the price to properly Chip Seal the street segment according to the conditions provided in this contract. Each segment will be bid as a “lump sum” price. It is the Contractors responsibility to review each street segment and verify the area to be chip sealed.

#### **408.6 Basis of Payment**

Chip Sealing will be paid for at the Contractors bid price per street segment. Which price shall be full compensation for furnishing; heating, unloading, hauling, and for applying the Chip Sealing material; for the cleaning of the streets, applying the Asphalt Emulsion and Chips, Rolling, street sweeping; for locating stockpile locations and disposal of all waste material, for the protection of inlets and utility casting; and for all labor, tools, equipment, and incidental necessary to complete the work as provided in the contract.

## Part V - Sewers and Sewer Structures

ARTICLE 501 - GENERAL.....	1
501.1 Description.....	1
501.2 Equipment.....	1
501.3 Inspection and Testing.....	1
501.4 Finishing Work and Maintenance.....	6
501.5 Measurement and Payment.....	7
501.6 Repairs and Replacement.....	7
ARTICLE 502 - TRENCH EXCAVATION, BEDDING, AND BACKFILL.....	10
502.1 Description.....	10
502.2 Measurement and Payment.....	20
ARTICLE 503 - SANITARY SEWER PIPES AND LATERALS.....	23
503.1 Description.....	23
503.2 Materials.....	23
503.3 Construction Methods.....	25
503.4 Measurement and Payment.....	31
ARTICLE 504 - STORM SEWER PIPES, APRON ENDWALLS AND OTHER STORM WATER CHANNELS.....	34
504.1 Description.....	34
504.2 Materials.....	34
504.3 Construction Methods.....	38
504.4 Measurement and Payment.....	41
ARTICLE 505 - BOX CULVERTS AND WINGWALLS.....	43
505.1 Description.....	43
505.2 Materials.....	43
505.3 Construction Methods.....	43
505.4 Measurement and Payment.....	44
ARTICLE 506 - STORM SEWER GATES.....	45
506.1 Description.....	45
506.2 Materials.....	45
506.3 Measurement and Payment.....	46
ARTICLE 507 - SEWER STRUCTURES.....	47
507.1 Description.....	47
507.2 Castings.....	47
507.3 Construction Methods.....	49
507.4 Measurement and Payment.....	57
ARTICLE 508 - UTILITY CROSSINGS.....	59
508.1 Description.....	59
508.2 Measurement and Payment.....	60

ARTICLE 509 - CURED-IN-PLACE PIPE (CIPP) REHABILITATION OF SANITARY SEWERS

..... 62

509.1	Description.....	62
509.2	Referenced Documents.....	62
509.3	Submittals.....	62
509.4	Requirements of Contractor.....	64
509.5	Materials.....	65
509.6	Construction Methods.....	68
509.7	Inspection and Testing.....	75
509.8	Measurement and Payment.....	78

## **ARTICLE 501 - GENERAL**

---

### **501.1 Description.**

Storm and Sanitary Sewer Construction shall consist of excavating the required trenches and tunnels; furnishing and laying therein pipe or monolithic concrete masonry sewers and required structures and appurtenances; backfilling the trenches; and restoring the site of the work; at the locations and to the required lines and grades; all as shown on the plan and provided by the contract.

The Concrete used in the construction and installation of sewers, sewer access structures, catchbasins, inlets, and other structures and appurtenances shall conform to the requirements for "Concrete and Concrete Materials" as specified in Part 3, Article 301 of these Specifications, unless otherwise specified.

All work done in the vicinity of any tree located in the terrace shall be completed in accordance with section 107.13 Tree Protection Specification.

### **501.2 Equipment.**

Equipment and tools necessary for performing all parts of the work shall be satisfactory as to design, capacity, and mechanical condition for the purposes intended, and any equipment which is not maintained in full working order, or which as used by the Contractor is inadequate to obtain the results prescribed, shall be repaired, improved, replaced or supplemented to obtain the progress and workmanship contemplated by the contract.

### **501.3 Inspection and Testing.**

#### **501.3(a) General.**

For all tests, the Contractor shall install, backfill and clean all sewer mains, sewer laterals, and any related appurtenances prior to performing the tests. All water main and services shall be installed prior to testing the sanitary sewer.

The cost of all testing by the Contractor shall be included in the unit price bid for the various sizes and types of sewer pipe installed. All testing by the Contractor shall be performed in the presence of the Engineer. Any testing not observed by the Engineer shall not be considered for acceptance by the City.

All delivered pipe shall be inspected. All material found to have cracks, flaws, or other defects will be rejected by the Engineer, and the Contractor shall promptly remove such defective material from the site of the work.

#### **501.3(b) Sanitary Sewer Gravity Main.**

All gravity sanitary sewers shall be required to pass a leakage test, mandrel test and inspection by a closed circuit internal television system prior to acceptance by the City. The leakage test may be either a water infiltration test or a low pressure air test. The Contractor shall furnish all equipment, materials, labor and other work necessary to complete the tests. The Contractor may perform either the water infiltration test or low pressure air test, except as specified below.

### Water Infiltration Test

After completion of pipe lines laid below the groundwater level and groundwater conditions have returned to normal, the line shall be tested for water infiltration. The water infiltration test shall be performed with a minimum positive head of two (2) feet. The length of the test shall be no less than one (1) hour in duration. The infiltration shall not exceed the rate of two hundred (200) gallons per day per mile of line per inch diameter of pipe being tested for any section of the system. Tests shall be performed for each run of pipe between sewer access structures, after groundwater conditions have returned to normal.

### Low Pressure Air Test

The section of sewer line to be tested shall be isolated by inflatable stoppers or other suitable test plugs. Air shall be added slowly to the test section until the pressure reaches 4.0 psig. After a pressure of 4.0 psig is obtained, the pressure shall be allowed to stabilize between 3.5 psig and 4.0 psig for at least two (2) minutes.

The test shall begin once the air supply is disconnected and the pressure decreases to 3.5 psig. The time for the pressure to drop 1.0 psig between 3.5 psig and 2.5 psig shall be recorded and compared to the total required test time as found in Table 1 - Low Pressure Air Test Times to determine if the rate of actual air loss is within the allowable limit. In computing the total required test time from Table 1, the required test time for the length and pipe size of any service connections (i.e. laterals) in the test section shall be added to the required test time for the length and pipe size of mainline sewer being tested.

If the total required test time elapses before the 1.0 psig pressure drop occurs, the test section shall be accepted. If the total required test time does not elapse before the 1.0 psig pressure drop occurs, the air loss rate in the test section shall be considered excessive and the section of pipe shall be considered to have failed the test. If the line fails the test, the Contractor shall, at his expense, locate and repair the source of leaks and retest the test section prior to acceptance.

It shall be noted that the aforementioned test pressures assume no groundwater is present over the pipe. If groundwater is present, the test pressures must be increased 0.43 psi for every foot of groundwater depth to offset the depth of groundwater over the sewer line. If the groundwater level is two (2) or more feet above the top of pipe at the upstream end of the section, or if the required test pressure is greater than 9 psig, the air test method should not be used and the water infiltration test shall be used in its place.



**TABLE 1**  
**Low Pressure Air Test Times**

Minimum allowable times (Min:Sec) for loss of air pressure from 3.5 psig to 2.5 psig for size and length of pipe indicated. (Based on 0.003 cfm per square foot with a minimum loss of 2.0 cfm and a maximum of 4.5 cfm.)

TEST LENGTH (FT.)	PIPE DIAMETER (INCHES)								
	4	6	8	10	12	15	18	21	24
25	0:05	0:10	0:18	0:28	0:40	1:03	1:31	2:03	2:41
50	0:09	0:20	0:36	0:56	1:20	2:05	3:01	4:06	5:21
75	0:14	0:30	0:53	1:23	2:00	3:08	4:32	6:09	8:02
100	0:18	0:40	1:11	1:51	2:40	4:10	6:02	8:12	10:42
125	0:23	0:50	1:29	2:19	3:20	5:13	7:33	9:55	11:20
150	0:27	1:00	1:47	2:47	4:00	6:15	8:30	9:55	11:20
175	0:32	1:10	2:04	3:14	4:40	7:05	8:30	9:55	11:20
200	0:36	1:20	2:22	3:42	5:20	7:05	8:30	9:55	11:20
225	0:41	1:30	2:40	4:10	5:40	7:05	8:30	9:55	11:20
250	0:45	1:40	2:58	4:38	5:40	7:05	8:30	9:55	11:53
275	0:50	1:50	3:15	4:43	5:40	7:05	8:30	10:02	13:04
300	0:54	2:00	3:33	4:43	5:40	7:05	8:30	10:57	14:15
325	0:59	2:10	3:47	4:43	5:40	7:05	8:43	11:52	15:26
350	1:03	2:20	3:47	4:43	5:40	7:05	9:24	12:47	16:38
375	1:08	2:30	3:47	4:43	5:40	7:05	10:04	13:41	17:49
400	1:12	2:40	3:47	4:43	5:40	7:24	10:44	14:36	19:00
425	1:17	2:50	3:47	4:43	5:40	7:52	11:24	15:31	20:11
450	1:21	2:50	3:47	4:43	5:40	8:20	12:04	16:26	21:23
475	1:26	2:50	3:47	4:43	5:40	8:47	12:45	17:20	22:34
500	1:30	2:50	3:47	4:43	5:55	9:15	13:25	18:15	23:45

### Mandrel Test

At the request of the Engineer, pipe 8-inches and larger shall be tested for acceptance with an approved go/no-go mandrel not less than thirty (30) days after the pipe has been installed, the backfill compacted, and other underground utilities within close proximity (such as water main) have been installed and backfilled but before paving is constructed. For acceptance, the mandrel must pass through the entire section between sewer access structures in one pass when pulled by hand without the use of excessive force.

The City shall supply a testing mandrel in conformance with the specifications of Standard Detail Drawing 5.1.1, Mandrel Detail, and the specifications of this section. The Contractor shall furnish the equipment and labor for making this acceptance test. The mandrel shall be of a shape similar to that of a true circle enabling the gauge to pass through a satisfactory pipeline with little or no resistance. The mandrel shall be of a design to prevent it from tipping from side to side and to prevent debris build-up from occurring between the channels of the adjacent fins or legs during operation. Each end of the core of the mandrel shall have fasteners to which the pulling cables can be attached. The mandrel shall have nine various sized fins or legs of appropriate dimensions for various diameter pipes. Each fin or leg shall have a permanent marking that states its designated pipe size and percent

deflection allowable. The diameter of the mandrel shall be equal to ninety-five (95) percent of the base inside diameter of the pipe. The Contractor shall furnish the engineer a table showing the base inside diameter and the five (5) percent deflection mandrel dimension for each pipe diameter called for in the plans. The base inside diameter shall be the minimum pipe inside diameter derived by subtracting the statistical tolerance package (defined below) from the pipe's average inside diameter.

For corrugated PVC pipe: Average inside diameter = average inside diameter.

For corrugated PE pipe: Average inside diameter = nominal inside diameter.

$$\text{Tolerance package} = (A^2 + B^2 + C^2)^{1/2}$$

Where: A = outside diameter tolerance (ASTM 949) for corrugated PVC pipe and inside diameter tolerance (AASHTO M294) for corrugated PE pipe.

B = excess wall thickness tolerance = 0 for both corrugated PVC pipe and corrugated PE pipe.

C = out-of-roundness tolerance (ASTM 949) for corrugated PVC pipe and 3% of nominal inside diameter for corrugated PE pipe.

Any section of completed pipe failing to pass this deflection test shall be repaired or replaced and retested at the Contractor's expense.

#### Closed Circuit Internal Television System

In the event defects in the sewer are detected by the closed circuit television inspection, the Contractor shall correct such defects prior to acceptance and final payment for sewers completed.

#### 501.3(c) Sanitary Sewer Force Main.

All completed sections of force main shall be hydrostatically field tested for exfiltration of water. The Contractor shall furnish the water necessary for the testing as well as all equipment, materials, labor and other work necessary to conduct the field tests and to make any necessary repairs or replacement.

The Contractor shall completely fill the pipe with water and expel all air from the pipe prior to testing. The test section shall be isolated through valves and/or watertight test plugs at each end.

During the test, the test section shall be subjected to a pressure of approximately 100 pounds per square inch gauge pressure (psig) at the point of highest elevation of the pipe under test. The length of the test shall be a minimum of one (1) continuous hour.

Leakage shall be defined as the quantity of water that needs to be supplied into the newly laid pipe, or any valved section of it, during the test in order to maintain the specified leakage test pressure.

Leakage shall not exceed the number of gallons per hour as determined by the following formula:

$$\text{GPH} = \frac{\text{ND}\sqrt{\text{P}}}{7400} \quad \text{where,} \quad \begin{array}{ll} \text{GPH} & = \text{gallons per hour} \\ \text{N} & = \text{number of joints under test} \\ \text{D} & = \text{nominal diameter of pipe in inches} \\ \text{P} & = \text{average pressure in pounds per square inch gauge during the test} \end{array}$$

In the event that the section under test contains joints of different diameters, the allowable leakage shall be the sum of the computed leakage for each size of joint.

Should any test section fail the leakage test, the Contractor shall, at his own expense, determine the source of the leakage, repair or replace all defective materials and/or workmanship to the satisfaction of the Engineer, and retest the section until a successful leakage test is obtained.

501.3(d) Storm Sewer Main.

The following section applies to corrugated polyethylene with smooth inner liner and corrugated polyvinyl chloride storm pipe as described in Section 504.2 - Materials of these Specifications.

At the request of the Engineer, pipe 8-inches and larger shall be tested for acceptance with an approved go/no-go mandrel after the pipe has been installed and the backfill compacted, and other underground utilities within close proximity have been installed and backfilled but before paving is constructed. For acceptance, the mandrel must pass through the entire section between sewer access structures or other structures in one pass when pulled by hand without the use of excessive force.

The City shall supply a testing mandrel in conformance with the specifications of Standard Detail Drawing 5.1.1, Mandrel Detail, and the specifications of this subsection. The Contractor shall furnish the equipment and labor for making this acceptance test. The mandrel shall be of a shape similar to that of a true circle enabling the gauge to pass through a satisfactory pipeline with little or no resistance. The mandrel shall be of a design to prevent it from tipping from side to side and to prevent debris build-up from occurring between the channels of the adjacent fins or legs during operation. Each end of the core of the mandrel shall have fasteners to which the pulling cables can be attached. The mandrel shall have nine various sized fins or legs of appropriate dimensions for various diameter pipes. Each fin or leg shall have a permanent marking that states its designated pipe size and percent deflection allowable.

For PVC storm pipe the diameter of the mandrel shall be equal to ninety-five (95) percent of the base inside diameter of the pipe. The Contractor shall furnish the engineer a table showing the base inside diameter and the five (5) percent deflection mandrel dimension for each pipe diameter called for in the plans. The base inside diameter shall be the minimum pipe inside diameter derived by subtracting the statistical tolerance package (defined below) from the pipe's average inside diameter.

For corrugated PVC pipe: Average inside diameter = average inside diameter.

$$\text{Tolerance package} = (\text{A}^2 + \text{B}^2 + \text{C}^2)^{1/2}$$

Where: A = outside diameter tolerance (ASTM 949) for corrugated PVC pipe.

B = excess wall thickness tolerance = 0 for corrugated PVC pipe.

C = out-of-roundness tolerance (ASTM 949) for corrugated PVC pipe.

For HDPE, the following size, 9 point mandrells shall be used by the Contractor for testing:

Nominal Size	Mandrell Size
12 inch Diameter	11.04 inches
15 inch Diameter	13.80 inches
18 inch Diameter	16.57 inches
24 inch Diameter	22.08 inches

These mandrells shall be provided by the City.

Any section of completed pipe failing to pass this deflection test shall be repaired or replaced and retested at the Contractor's expense.

#### 501.3(e) Sewer Access Structures.

Sewer access structures shall be individually tested for infiltration when directed by the Engineer. The rate of infiltration shall not exceed two hundred (200) gallons per day per mile of vertical height (wall only) per inch internal diameter (or maximum horizontal dimension of structure). Two hundred (200) gallons per day per mile of vertical height per inch internal diameter equals to the following rates:

Maximum allowable sewer access structure infiltration:

- 48" dia. sewer access structure = 0.0758 gallons per vertical foot per hour
- 60" dia. sewer access structure = 0.0947 gallons per vertical foot per hour
- 72" dia. sewer access structure = 0.1136 gallons per vertical foot per hour

In the event the water infiltration or the loss of air exceeds the rates specified, the Contractor shall locate the point or points of leakage and repair the pipe line or sewer access structure as directed by the Engineer at the expense of the Contractor. All visible leaks in sewer access structures shall be repaired even though the leakage test requirements are met. Acceptance and final payment for sewers completed shall not be made until any leakage, which exceeds the rate specified, has been corrected.

#### 501.4 Finishing Work and Maintenance.

The Contractor shall maintain all trenches, keeping them well filled and in a safe condition for travel, and shall deliver to the City, at the time of acceptance, a finished job with all trenches in a condition satisfactory to the Engineer.

All concrete, asphalt, and gravel pavements; stone flagging or paving; sidewalks; curbs and gutters; culverts; fences; or other structures; which may have been damaged or displaced by the Contractor in constructing the sewer shall be rebuilt or relaid properly to the original line and grade in accordance with pertinent parts of these Specifications, or in the absence of applicable specifications, to the original condition of the structure.

The Contractor shall maintain all asphalt and gravel surfaces, restored and replaced as above, in first class condition until final acceptance of the project is made by the Common Council. Failures

occurring during the required guarantee period shall be repaired by the Contractor at no additional cost to the City.

All new or relaid sewers and structures shall be cleaned of any accumulations of silt, debris, and other foreign matter, and prior to acceptance, such installations shall be tested with water or by other approved methods, and under such tests unimpeded flow shall be indicated.

The area along the whole sewer shall be left clean and graded in a condition satisfactory to the Engineer.

Unless otherwise provided, costs of the work included in this Section shall be at the expense of the Contractor, and shall be included in the unit prices bid for the contract items with which such work is associated. Final payment will be withheld until such work is done in a manner satisfactory to the Engineer.

### **501.5 Measurement and Payment.**

Only that work will be measured for payment which is completed and accepted in accordance with the terms of the contract.

The contract prices for the various items shall include all equipment, tools, labor and incidentals necessary to complete the work as specified.

### **501.6 Repairs and Replacement.**

#### **501.6(a) Pipes.**

When compliance with these Specifications require, all pipe repairs shall be made by replacement of the defective pipe section with new, equal quality pipe. Alignment, grade, bedding and backfilling shall be done in accordance with these Specifications.

All field cuts of all types of pipe, except reinforced concrete pipe and corrugated metal pipe, shall be made with an approved mechanical pipe cutter or with a power saw in order to make a straight, true cut without chipping and cracking the pipe.

For joining the replacement sections, approved compression couplings conforming to the requirements of Compression Couplings for Vitrified Clay Plain-End Pipe, ASTM Designation: C425, Type A, with shear bands shall be used whenever possible. In no case will concrete encasement of defective pipe be allowed. A Poly (Vinyl Chloride) (PVC) Repair Coupling shall be used to repair a cracked or broken section of PVC pipe per Standard Detail Drawing 5.3.3 – Coupling Details as approved by the Engineer. All repairs involving pipe connections 8” in diameter or larger than 8” in diameter shall use the FERNCO RC Strong Back or equal repair coupling (ASTM C1173). These repairs shall include total and complete restoration of any disturbed surface to original or better than original condition which existed before the repair, regardless of improvements on lands where the repair is required. Unless otherwise provided, all cost of the work included in this Subsection shall be at the expense of the Contractor.

501.6(b) Reinforced Concrete Box Culverts.

Reinforced concrete box culverts (RCBC) roof repairs shall include the removal of the rectangular casting and reconstruction of the roof to provide a new 24 inch diameter opening for a nine (9) inch casting as specified in Section 507.2 – Castings of these Specifications. The RCBC Roof Repair shall be measured as each completed and accepted unit. The RCBC Roof Repair shall be either TYPE I or TYPE II as described below and further detailed in Standard Detail Drawing 5.1.2, RCBC Repair Type I or Type II:

**TYPE I:** A Type I repair is intended for any structure that has enough cover to fit the new eight (8) inch roof (placed on top of the existing roof), adjustment and nine (9) inch casting. It is the Contractor's responsibility to verify all access points to determine the type of repair needed prior to completing the work. The existing roof access point shall be left in place. Any structural defects shall be sawcut and removed to a clean edge.

A new reinforced concrete roof (eight (8) inches minimum thickness) shall have #4 rebars placed six (6) inches on center, both ways, and shall have a minimum of three (3) inches of clear space from the edge of concrete. A minimum of eight (8) inches of overlap longitudinally from the existing roof cutout shall be provided with the new roof. The new roof shall be flush with the vertical walls of the box culvert.

The roof shall be poured and cured on a flat surface prior to being placed on top of the existing box. SealTight Cold Plastic Sewer Joint compound (as manufactured by W.R. Meadows or approved equal) shall be applied to the top of the box and the roof shall be placed on top of the existing cutout to for a tight seal. All joints shall be sealed with mortar or mastic. The box culvert shall be cleaned and free of debris prior to placing the mortar or mastic.

**TYPE II:** A Type II repair is intended for any structure that will not have enough cover to fit the new eight (8) inches roof (placed on top of the existing roof), adjustment and nine (9) inch casting. It is the Contractor's responsibility to verify all access points to determine the type of repair needed prior to completing the work. The existing roof shall be sawcut and removed, at the location shown on the plans or as directed in the field by the Engineer, to remove the existing rectangular opening and any structural defects to a clean edge.

The reinforced concrete shall have #4 rebars spaced approximately six (6) inches on center, both ways, as detailed in the plans. The dowels shall be a minimum of three (3) inches clear of the edge of the repair rot o the exposed edge of the box. #6 smooth rebars, 12 inches on center, shall be doweled longitudinal a minimum of six (6) inches into the existing box culvert roof. All dowels shall be grouted into place with epoxy mortar. The roof shall match the existing box culvert roof thickness (8-10 inches, typical).

If the roof is poured in place it is anticipated that falsework would be required. Falsework supporting concrete structures shall remain in place a minimum of three (3) days for spans of new concrete of twelve (12) feet or less, and for six (6) days for spans of twelve (12) feet or greater, which shall be exclusive of days in which the concrete has been exposed to temperatures below 40 degrees F. Backfilling may

proceed after three (3) days. Falsework shall be constructed and placed to support the new concrete roof as it is poured in place. High early strength concrete with a cure time of three (3) days shall be used for all repairs. Sandbag diversions or pumping may be utilized at the Contractor's discretion while the falsework is in place. Any sandbags or pumping shall be considered incidental to accomplish the work as described. The Contractor shall be responsible for removing all falsework and sandbag diversions at the end of the cure time. Any damage incurred as a result of not removing these items shall be at the Contractor's expense. Repairs shall not be deemed acceptable until all falsework and/or sandbag diversions removed.

If the new roof is constructed separately from the box, the roof shall be poured and cured on a flat surface prior to being placed on top of the existing box. SealTight Cold Plastic Sewer Joint compound (as manufactured by W.R. Meadows or approved equal) shall be applied to the top of the box and the roof shall be placed on top of the existing cutout to form a tight seal. The new roof shall fit tightly onto the existing box and the new roof. The gap between the new roof and the existing roof shall be filled with SealTight Cold Plastic Sewer Joint compound and an eight (8) inch wide ¼ inch steel plate shall be placed across the entire width of the box, centered over the joint. If the new roof is poured separately, longitudinal dowel bars shall not be required.

All repair joints shall be sealed with SealTight Cold Plastic Sewer Joint compound in the interior and exterior of the box culvert to ensure a watertight seal. The box culvert shall be cleaned and free of debris prior to placing the mortar and mastic.

Any temporary plating required to accomplish the work as described above shall be incidental to this item.

#### 501.6(c) Sanitary Sewer Access Structures.

Reconstruct Bench and Flowline(s) shall include the reconstruction of an existing sanitary sewer access structure bench and flowline(s) to accommodate changes in pipe sizes, alignments and/or grades of the incoming and outgoing pipes when it is determined by the Engineer that the existing structure shall remain in place. Work shall be done such that the structure and structure floor remain structurally sound after the reconstruction. If it is determined either during a tap or a reconstruction of the bench and flowline(s) that the structure does not have a solid, structurally sound floor, the work shall include the placement of a new structure floor. Work shall include excavating one foot minimum below the invert of the outgoing pipe, placement of a six (6) inch minimum compacted granular material base, and placement of a new poured concrete floor. All work shall be measured and paid for as each completed unit. Finished flowlines shall have a smooth troweled finish. Brushed flowlines will not be accepted.

## **ARTICLE 502 - TRENCH EXCAVATION, BEDDING, AND BACKFILL**

---

### **502.1 Description.**

#### **502.1(a) Trench Excavation.**

Unless otherwise provided in the contract or permitted by the Engineer, the work of constructing sewers and allied works shall be done in open trenches and in a manner to protect the pipe lines or sewers from unusual stresses. When provided in the contract or permitted by the Engineer, the construction of sewers may be done by tunneling and/or jacking in lieu of open trenching; details of construction shall be indicated on the plan, specified in the contract, or established by the Engineer prior to beginning the work of tunneling and/or jacking. All of the work of constructing sewers shall be done in accordance with the applicable provisions of the “Wisconsin Administrative Code”.

The trenches shall be excavated in conformity with the required alignment and grades as shown on the plans and as laid out in the field by the Engineer. It shall be understood that the elevations for sewers, as shown on the plans, are subject to such revisions as may be necessary to fit field conditions and that the Engineer reserves the right to adjust the profile grades from those shown on the plan. No adjustment in compensation will be made for the grade adjustments not in excess of one (1) foot above or below the elevations shown on the plans.

The Contractor shall remove all vegetation along the trench line to the width of the proposed trench before beginning excavation. Vegetation removed shall not be used as backfill in the trench, but shall be disposed of by the Contractor at no additional cost to the City. If the trench line is finished with pavement or other structures, removal of those items shall be completed as specified in Article 203 – Removal of Miscellaneous Structures with the exception that the sawcut shall be incidental to the trench excavation.

The materials excavated from the trench shall be deposited on the sides of the trenches and excavations, beyond the reach of slides, or transported to spoil banks. For pipe sewers, the width of the trench shall be such as to leave a clear space of not less than six (6) inches nor more than twelve (12) inches between the earth wall, or the supporting sheeting or bracing where such is used, and the sides of the pipe. The trench width established by this pipe clearance, measured at the spring line, shall be applicable to that portion of the trench from one (1) foot above the top of the pipe to the bottom of the trench. On streets opened to traffic, on restricted easements, and in such other locations as the Engineer directs, the width of the trench at the surface of the ground shall be limited to the outside diameter of the pipe plus two (2) feet plus the amount necessary for sheeting or bracing.

Surplus material shall be considered to include vegetation from the trench line, excavated rock or boulders larger than six (6) inches in diameter, and all other material from excavation not needed or suitable for backfilling trenches. Unless otherwise specified, surplus material shall be the property of the Contractor, and shall be disposed of at no additional cost to the City.

Unless otherwise provided, the Contractor shall provide all the sheeting or bracing needed to protect the work, existing property, utilities, pavement, etc., and to provide safe working conditions in the trench. Such sheeting and bracing shall be according to the Contractor’s design and shall comply with the “Wisconsin Administrative Code”. Removal of any sheeting or bracing from the trench shall be accomplished in such a manner as to fulfill the above requirements. Sheeting and bracing shall be removed unless specific permission is given by the Engineer to leave it in place. Costs of this work shall be at the Contractor’s expense.



The Engineer reserves the right to limit the extent of excavation in advance of pipe laying and backfilling depending on the nature of the soil and other conditions affecting the work.

The Engineer reserves the right to order additional excavation where unsuitable foundation conditions exist. When this condition arises, the excavation shall be carried to such depth as directed by the Engineer. The maximum width of the extra trench excavation shall be the outside of the proposed structure plus two (2) feet plus the amount necessary for sheeting or bracing. Mechanically compacted crushed stone and/or washed gravel shall be installed to replace the excavated materials to subbase grade.

When directed by the Engineer, the Contractor shall uncover utility lines within the proposed construction limits in advance of the construction as specified in Article 508. Work necessary to expose existing underground facilities that are part of the Contractor's statutory obligation during the normal storm sewer, sanitary sewer, electrical conduit or water main installation shall be considered as incidental to those respective items and will not be paid for as utility line openings.

#### 502.1(b) Rock Excavation.

Rock excavation shall include all hard, solid rock in ledges, bedded deposits and unstratified masses and all conglomerate deposits or any other material so firmly cemented as to present all the characteristics of solid rock; which material is so hard or so firmly cemented that, as determined by the Engineer, it is not practical to excavate and remove same with a power shovel except after thorough and continuous drilling and blasting. Power shovels as referred to above shall be taken to apply to a modern power shovel or backhoe of not less than three-quarters cubic yard manufacturer's rated capacity, having adequate power and being in good running condition in the hands of an experienced operator. Rock excavation shall also include all rock boulders necessary to be removed having a volume of one (1) cubic yard (9 cubic feet) or more. Rock excavation shall not apply to plain or asphaltic bound bases or surface courses of macadam, gravel, or broken stone.

Rock excavation shall be carried to a depth of six (6) inches below the outside of the sewer, and to a width limited to the outside diameter of the pipe plus two (2) feet. Rock excavation shall be carried to a depth of eight (8) inches below the outside of the sewer for sewer access structures up to ten (10) feet deep and twelve (12) inches below the outside of the sewer for sewer access structures over ten (10) feet deep. The horizontal limit for rock excavation shall be the outside dimensions of the sewer access structure plus two (2) feet.

#### 502.1(c) Dewatering.

The Contractor shall provide and maintain ample means and devices with which to promptly remove all water entering excavations, trenches, and other parts of the work and shall keep said excavations dry until the structures to be built therein are completed. No masonry shall be installed in water nor shall water be allowed to rise over masonry and concrete until the mortar and concrete have attained final set. In no event shall water be allowed to rise over masonry or concrete if there is danger of flotation or of setting up unequal pressures in the concrete until the concrete has set at least twenty-four (24) hours and any danger of flotation has been removed. Dewatering shall be either TYPE I or TYPE II as described below:

**TYPE I: TRENCH DEWATERING AND POINTS/WELLS DEWATERING WITH PUMP RATES LESS THAN 70 GALLONS PER MINUTE (AGGREGATE TOTAL).**

If the Contractor chooses to use trench dewatering techniques (no limit on pump rates) or a point/well system that in total pumps <70 g.p.m., the permitting of these activities is covered by the City of Madison's Construction Site General Permit obtained from the Wisconsin Department of Natural Resources (WDNR) for the project. As such, the Contractor shall be responsible for complying with the erosion control requirements listed in the Table 2 - Dewatering Practice Selection Matrix.

**TYPE II: POINTS/WELLS WITH PUMP RATES GREATER THAN OR EQUAL TO 70 GALLONS PER MINUTE (AGGREGATE TOTAL).**

If the Contractor chooses to dewater the site with points/wells with total pump rates equal to or greater than 70 g.p.m., the Contractor shall obtain a permit for installation of groundwater control well/s from the Wisconsin Department of Natural Resources (WDNR) in accordance with paragraph 144.025(2)(e), Wisconsin Statutes. All wells shall be drilled and sealed in accordance with requirements of the WDNR for installing and abandoning wells. The address for obtaining well permits is:

Wisconsin Department of Natural Resources  
Private Water Supply Section  
Box 7921  
Madison, Wisconsin 53707

When the Contractor chooses to obtain a water supply permit for dewatering, he/she shall provide erosion control at the discharge point as required to meet the conditions of the permit. At a minimum the Contractor shall provide silt fence, riprap, sedimentation basins or other approved means to minimize erosion and dissipate energy from the discharge point of pumped water.

Further, where the discharge (as permitted by the private water supply permit) has the potential to cause an adverse impact on the quality of the receiving water, a Wisconsin Pollutant Discharge Elimination System (WPDES) permit may be required by the WDNR. If a WPDES permit is required the Contractor shall file for this permit with the WDNR, and comply with any and all requirements of that permit. If discharge testing is required by the WPDES permit the Contractor shall:

- (1) Arrange for independent testing laboratory to sample and analyze discharge water for particulates at frequency indicated within WPDES permit. Where particulates exceed specified limits, the Contractor shall take such measures as are required to improve water quality to meet standards.
- (2) Construct any sedimentation basins used to meet the requirements of the WPDES discharge permit to meet the requirements of "Wisconsin Construction Site Best Management Handbook" or its' successors.

The Contractor shall be solely responsible for choosing a method of groundwater control, which is compatible with the constraints defined herein. The Contractor shall be responsible for the adequacy of the groundwater control system and shall take all necessary measures to ensure that the groundwater control operation will not endanger or damage any existing adjacent utility or structure.

The Contractor shall submit in writing to the Engineer his proposed method of dewatering for this project prior to its use.

The method or methods shall be designed, installed and operated in such a manner to provide satisfactory working conditions and to maintain the progress of work. The methods and systems shall be designed so as to avoid settlement or damage to adjacent property in accordance with the applicable legislative statutes and judicial decisions of the State of Wisconsin. All required pumping, drainage and disposal of groundwater shall be done without damage to adjacent property or structures, or to the operations of other Contractors and without interference with the access rights of public or private parties.

The dewatering system must remain in place until all excavation, backfilling and compaction is completed.

The Contractor shall be responsible for adhering to all requirements of the dewatering permit including reporting requirements.

**TABLE 2 - Dewatering Practice Selection Matrix**

Type of Dewatering Practice	Soil and Texture Classification		Notes
	Silty Soils	Clay Soils	
<b>Geotextile Bags</b>			
Type I	.....		See Table 3 for Bag Specifications & Sizing
Type II	oooooooooooooooo	.....	See Table 3 for Bag Specifications & Sizing
<b>Gravity Based Settling</b>			
Sediment Tank (Dumpster with no screens)	.....		
Sediment Trap (Temporary)	.....		Use SOC Standards 1063 or 1064
Sediment Basin (Temporary)	oooooooooooooooo	.....	Use SOC Standards 1064
Wet Detention Basin (Permanent)	oooooooooooooooo	oooooooooooooooo	Use SOC Standards 1001
<b>Passive Filtration</b>			
Filter Tank (Dumpster with screens)	oooooooooooooooo	.....	See Table 3 Notes for Screen Requirements
Filter Basin	.....		
Vegetative Filter	oooooooooooooooo	oooooooooooooooo	Effectiveness depends upon the width of the filter and the runoff rate of flow. See Standard 1054 for design guidelines for sizing information. Not appropriate for pumping without primary treatment via a geotextile bag of sediment tank.

**Key:**

Effective range of device 0000000000000000  
 Effective range with addition of polymer .....

**Notes:**

- (1) The effectiveness of many practices can be enhanced through the use of polymer mixture.
- (2) Soils classification shall be done in accordance to USDA method.
- (3) Standard 1063 Sediment Trap
- (4) Standard 1064 Sediment Trap
- (5) Standard 1054 Vegetated Buffer for Construction Sites
- (6) Standard 1001 Wet Detention Basin
- (7) Discuss alternate options with the regulatory authority
- (8) SOC = Standards Oversight Council - [www.dnr.STATE.wi.us/org/water/wm/nps/stormwater/techSTDS.htm](http://www.dnr.STATE.wi.us/org/water/wm/nps/stormwater/techSTDS.htm)

**Note:**

Type of soil expected shall be noted in the contract. Contractor shall recognize that if clay soil is expected, only a Type II bag or filter fabric tank with the addition of polymer, is an accepted treatment method.

**TABLE 3: Properties for Geotextile Bags**

Property	Test Method	WDOT Type R	WDOT Type HR
		Type I Value	Type II Value
Maximum Apparent Opening Sizes	ASTM D-4751	0.212 mm	0.212 mm
Grab Tensile Strength	ASTM D-4632	200 lbs.	300 lbs.
Mullen Burst	ASTM D-3786	350 psi	580 psi
Flow Gallon/min/sf	ASTM D-4491	50	30
Fabric	Nominal Representative Weight	8 oz	12 oz

Table 3 Notes:

- 1) Sizing on filter bags shall be done as follows. The smallest acceptable bag regardless of the following shall be a minimum of 3 ft wide 1 ft in vertical depth (measured at the center of bag) and a minimum of 6 ft long. Bag sizing shall be the larger of either the City minimum above or the length \* width of the proposed bag \* the flow rate of fabric per square foot divided by 2 to calculate the acceptable flow to that size bag.
- 2) Filter tanks shall have a minimum of one (1) screen in place prior to discharge. This screen shall be made of WDOT Type HR Fabric. Once the screen is “over topping”, the screen shall be changed, the pump rate decreased or a second/larger dumpster with filter screen shall be added to the treatment system.

**502.1(d) Bedding of Sewer Pipes.**

The bedding, or foundation, for sewer pipes shall be constructed to prevent settlement of the pipes and to avert excessive pressure on the pipes in order to avoid rupture, leakage or deformation of the pipes. Unless otherwise specified in the Special Provisions of the contract, all sanitary and storm sewer pipes, including sanitary sewer laterals and storm sewer leads, shall be constructed with the

type of bedding that is specified for the type of pipe installed, as shown on the Standard Detail Drawing 5.2.1, Storm and Sanitary Sewer Beddings.

The width of the bedding shall be equal to the width of the trench. The depth of the bedding shall extend from an elevation at least six (6) inches below the bottom of the pipe to an elevation at least twelve (12) inches above the top of the pipe. All bedding shall be mechanically compacted, including crushed stone and washed gravel.

Sand or limestone screenings used for bedding shall conform to the following gradation:

Passing 3/4" sieve	100%
Passing #200 sieve	0-10%

Washed gravel and crushed stone used for bedding shall conform to the following gradation:

Passing 1" sieve	100%
Passing 1/2" sieve	35-60%
Passing #200 sieve	0-10%

Washed gravel or crushed stone shall be used for all pipe sizes over ten (10) inches in diameter, and for smaller sizes when directed by the Engineer. With the approval of the Engineer, the maximum size of the washed gravel or crushed stone may be increased, and screened crushed stone may be substituted for washed gravel.

#### 502.1(e) Backfilling Excavations and Compaction of Backfill.

Unless otherwise provided, all trenches and excavations shall be backfilled immediately after the sewers and appurtenances have been constructed therein. In covering the sewers and filling around structures, the backfill material shall be brought up evenly on all sides so that no unbalanced pressure is brought to bear upon the pipe and masonry.

The Contractor shall be required to backfill all excavations to the original ground elevation unless otherwise specified in the contract or ordered by the Engineer. In the event of a shortage of material to perform this work, including replacement as may be required by rock excavation or removal of boulders, the Contractor shall provide the necessary material at no additional cost to the City.

Walking or working on the completed pipe sewers, except as may be necessary in compacting and backfilling, shall be prohibited until the trench has been backfilled to an elevation at least two (2) feet above the top of the pipe. No trucks, vehicles, or other equipment shall be allowed within the limits of the trench prior to the completion of the backfilling operations, unless authorized by the Engineer for compaction or other purposes.

Backfill material hauled to the project shall be dumped along the top of the trench beyond the reach of slides and placed in the trench with the proper backfilling equipment. Backfill material may be dumped directly into the trench from trucks when the amount of material to be dumped is controlled by partially opening the tailgates, and only when authorized by the Engineer.

Trenches shall be hand backfilled to an elevation at least one (1) foot above the top of the pipe. The material for this portion of the backfill shall not contain stones, or hard or frozen lumps of earth. For plastic sewer pipes, this material shall be the same classification as the bedding. The equivalent of

hand backfill may be accomplished by lowering a clam bucket or material to a point immediately above and approximately one (1) foot from the sewer and slowly releasing the fill; for reinforced concrete pipe or corrugated metal pipe, the material may be deposited on a slope, equal to the angle of repose of the material, and allowed to flow progressively forward in such a manner as to avoid impact on the pipe and to avoid uneven pressures on either side of the pipe which may disturb its grade or alignment. Backfill material shall not be taken from trench walls below an elevation of two (2) feet above the top of the pipe. The remainder of the trench shall then be filled carefully in a manner satisfactory to the Engineer. The compaction sections are detailed in Standard Detail Drawing 5.2.2, Typical Trench Compaction & Standard Detail Drawing 5.2.3, Typical Trench Compaction (Greenway/Park).

All corrugated metal culverts shall be hand backfilled and mechanically tamped to an elevation at least one (1) foot above the top of the culvert. Extreme care shall be taken so as to assure complete filling and compaction under the culvert and between the culvert and the walls of the trench. If trucks or other heavy equipment used on the project are to travel over the newly installed culvert, then the Contractor shall place a minimum cover of twelve (12) inches of fill over the culvert to protect it during this period. This protective layer of fill shall be thoroughly mechanically compacted.

In the event that excavations have been sheathed or braced, the Contractor shall carefully draw and remove the sheathing and bracing in a manner which will not disturb the completed work. All openings left in removing sheathing and bracing shall be carefully filled with approved backfill material and properly compacted.

The backfilling of structures shall conform to the requirements specified in Section 301.8 - Protection of the Concrete of these Specifications.

The backfilling of tunnels and shafts for tunneling and jacking operations shall be in accordance with the requirements specified in the contract. Where not specified in the contract, such backfilling shall be as directed by the Engineer.

Where the grade of the sewer is such that, in the opinion of the Engineer, the top surface of the sewer shall require protection, an embankment of earth or other material, satisfactory to the Engineer, shall be constructed over the sewer by the Contractor. The height of the embankment shall be one (1) foot above the top of the pipe unless otherwise specified or directed by the Engineer. The width at the top of the embankment shall be not less than two (2) feet wider than the external width of the sewer. The sides of the embankment shall slope from the top of the embankment to the existing ground surface in a ratio of not less than two (2) feet horizontally to one (1) foot vertically. The material used to construct the embankment shall be such surplus material excavated from trenches as shall be approved by the Engineer. Such selected material shall be furnished and placed in the embankment by the Contractor at no extra cost to the City. Should more material be needed to complete the embankment than can be obtained from surplus material excavated, such material shall be furnished by the Contractor, and will be paid for as provided herein. The material shall be compacted as provided in Subsection 202.3(b) – Standard Compaction of these Specifications.

All material used for backfilling trenches and other excavations shall be subject to the approval of the Engineer. Unless otherwise specified or directed by the Engineer, the Contractor shall backfill trenches and other excavations with materials excavated in the course of the work. Whenever specified in the contract or directed by the Engineer, trenches and other excavations shall be backfilled with Select Fill. Vegetation and stones or fragments of broken rock in excess of six (6) inches in any dimension shall not be included in the backfill. In the event the Engineer rejects the

excavated materials for backfilling due to the character of the material, including excess moisture content, gradation, composition, frozen material, or for whatever cause, the Contractor shall backfill the trenches and other excavations in the specified manner with Select Fill. In the event of lack of moisture in the backfill materials, the Contractor shall add water in quantities deemed necessary to secure the required compaction. In the event the excavated materials contain excess moisture, the Contractor shall, as directed by the Engineer:

1. Suspend all work on the project for that period of time as may be necessary to allow the backfill materials to dry sufficiently prior to backfilling and compacting the backfill material, during which time work days shall not be charged against the Contractor, or
2. Replace the excavated materials, in whole or in part, with Select Fill.

Where the moisture content of the excavated materials is such that drying or adding water is necessary prior to backfilling and compaction, the Contractor may furnish acceptable materials for the backfill and dispose of the excavated materials, all at no additional cost to the City.

Select Fill for backfilling trenches and other excavations shall be material as defined in Subsection 202.2(b) – Select Fill of these Specifications and shall be measured and paid as defined in Subsection 502.2(g) – Select Backfill for Sewer of these Specifications. Excess excavated material resulting from the above work may be used in backfilling other trench areas, unless the material is declared unsuitable for backfill by the Engineer, in which case the material shall be considered surplus material and shall be disposed of by the Contractor at no additional cost to the City.

Unless otherwise specified or directed by the Engineer, the backfill in all trenches and excavations shall be mechanically compacted in such a manner as to thoroughly consolidate the backfill material and not injure or disturb the pipe or other structure. The compaction of the backfill material shall be in accordance with the following requirements:

1. The material for the backfill shall be deposited, spread and leveled, as herein before provided, in layers generally not exceeding twelve (12) inches in thickness before compaction, except that when the material being compacted is of a granular nature and the compacting equipment is adaptable for the purpose, the thickness of the layer may be increased to a maximum of twenty-four (24) inches provided the required density is obtained. Each layer of the spread and leveled material shall be compacted, by means of suitable compaction equipment, to not less than the specified density before the succeeding layer is placed.
2. All Pipe Trenches shall be compacted in conformance of Standard Detail Drawings 5.2.2 Typical Trench Compaction and 5.2.3 Typical Trench Compaction (Greenway Park). Compaction of the backfill material shall not begin until the depth of the backfill material is two (2) feet above the top of the pipe. In the case of structures, compaction of the backfill material shall begin with the placing of the first layer of backfill material. Backfills of three (3) feet or less in depth below the proposed or existing subgrade shall be compacted to at least ninety-five (95) percent of maximum density for their full depth.

In city right of ways or as called for by the construction engineer, backfills over three (3) feet in depth below the proposed or existing subgrade shall have the top three (3) feet below the proposed or existing subgrade compacted to not less than ninety-five (95) percent of

maximum density, and those portions more than three (3) feet below the proposed or existing subgrade shall be compacted to at least ninety (90) percent of maximum density.

In greenways and parks, in accordance to Standard Detail Drawing 5.2.3, backfills over three (3) feet in depth below the proposed or existing subgrade shall be compacted to at least ninety (90) percent of maximum density. If the proposed pipe is located horizontally within 15' of an existing or proposed asphalt or concrete surface, then the pipe compaction shall be completed in conformance of Standard Detail Drawing 5.2.2.

3. The maximum density shall be determined in accordance with the Standard Method of Test for the Moisture-Density Relations of Soils, ASTM Designation: D 1557, Method D, with replacement of the fraction of material retained on 3/4-inch sieve with No. 4 to 3/4-inch material. The density of compacted backfill material shall be determined in accordance with the Test for Density of Soil-in-Place by the Sand-Cone Method, ASTM Designation: D 1556, the Test for Density of Soil and Soil-Aggregate in Place by Nuclear Methods, ASTM Designation: D 2922, or by other approved methods.
4. In the event the material in the density sample differs in percentage of aggregate retained on a No. 4 sieve from that in the sample upon which maximum density was determined, the maximum density shall be adjusted in accordance with approved procedure.
5. The foregoing density requirements will not apply to portions of backfills constructed of materials which, because of numerous large stones or high percentages of material retained on the No. 4 sieve, cannot in the determination of the Engineer be accurately tested in accordance with the above procedures for determining maximum or in place dry density.

Whenever the work of installing sewers takes place during cold weather, the specifications for trench compaction above shall be followed if practicable. If the specified compaction cannot be achieved, and the Engineer directs that the work may not be suspended until more favorable weather conditions exist, then the following procedures shall be followed:

1. All frozen material in the trench shall be removed before beginning the day's work. As a method to achieve this, trenches shall be closed overnight.
2. Materials shall be unfrozen when being compacted.
3. The material shall be compacted in six (6) inch lifts in a manner normally done during warm weather construction and to a minimum density of ninety (90) percent compaction below the three (3) foot depth.
4. If the top three (3) feet of material does not meet ninety-five (95) percent compaction, then pit run sand (hailed in if necessary) shall be compacted in the normal manner using six (6) inch lifts.
5. The Engineer will have tests performed as necessary to provide uniformity of compaction.
6. As a guideline, construction should cease when the temperatures are too cold to achieve the above. At least 15°F and rising is a reasonable temperature if it is not extremely windy.



502.1(f) Utility Trench Patches.

Whenever shown on the plans, or directed by the Engineer, the Contractor shall restore existing pavements through which new utility installations pass in accordance with the Standard Detail Drawing 5.2.4, Typical Pavement Patch Sections, for the type of pavement patch specified and installed. The asphalt pavement material in utility trench patches greater than six (6) feet in either direction shall be compacted with a self-propelled vibratory roller capable of meeting the yields specified in Section 402.3 - Asphalt Pavement of these Specifications. Utility trench patches shall be classified and identified as follows:

**TYPE I:** Nine (9) inch reinforced concrete pavement, to be installed in existing concrete pavements. The pavement along the patch shall be sawcut, full depth, and incidental to the trench patch.

**TYPE II:** Seven (7) inch plain or reinforced concrete base or asphaltic base, where specified or directed by the Engineer, overlaid with asphalt pavement, to be installed in pavements with concrete bases surfaced with asphalt pavements.

**TYPE III:** Ten (10) inch crushed stone base overlaid with asphalt pavement equal in thickness to the existing asphalt pavement, 3" minimum thickness and maximum 5 1/4" thickness, to be installed in pavements with crushed stone bases surfaced with asphalt pavements. The pavement along the patch shall be sawcut, full depth, and incidental to the trench patch. The edges of the existing asphaltic pavement shall be free of loose stones or pavement material.

**TYPE IV:** Nine (9) inch crushed stone pavement to be installed in unpaved or un-surfaced streets.

**TEMPORARY:** Seven (7) inch concrete pavement, to be installed when the existing ground or pavement in the area of the patch is frozen or contains frost. Temporary patches shall not be constructed of crushed stone and/or asphaltic materials unless specifically authorized by the Engineer.

During the construction of the patch, the area shall be plated, barricaded, or otherwise protected as directed by the Engineer, until the patch is complete and can be opened to traffic.

Patches shall be restored on the same day the pavement is removed on streets classified as arterial or collector. Patches shall be restored within three (3) calendar days from when the pavement was removed on streets classified as local.

Asphalt mixtures shall not be placed when the air temperature approximately three (3) feet above ground at the site of the work, in the shade and away from the effects of artificial heat, is less than 32°F.

If an excavation in the roadway encounters filter fabric, the Contractor will not be required to replace the filter fabric if the excavation removes all of the soft soils down to stable soils. If the excavation does not extend to stable soils, the Contractor shall replace the filter fabric. The Contractor shall carefully cut the fabric along the center line of the trench and fold back during the excavating process. When the excavation is backfilled to the level of the filter fabric, the fabric shall be folded back down on the compacted backfill material and a new layer of filter fabric shall be placed over the

existing fabric. The new fabric shall be overlapped a minimum of twelve (12) inches on each side. The new filter fabric shall meet or exceed the specifications for the existing fabric.

In the event that the filter fabric is destroyed during the excavation procedure the Contractor shall replace the filter fabric on the entire trench. The excavation over the existing fabric shall be widened to provide for a twelve (12) inch overlap of the existing fabric.

## **502.2 Measurement and Payment**

### **502.2(a) Trench Excavation.**

All trench excavation necessary for the construction of sanitary or storm sewer systems shall be included in the item that requires the excavation.

### **502.2(b) Additional Excavation, Including Undercut.**

Any work involved in forming a satisfactory foundation at depths of one-half (1/2) foot or less below the bottom of the pipe will be considered as incidental. Additional excavation, including undercut beyond one-half (1/2) foot, shall be measured in the field and the volume in cubic yards shall be computed from those measurements and paid for as extra work. The maximum width of the additional excavation or undercut, shall be the outside dimension of the pipe or structure plus two (2) feet plus the amount necessary for sheeting and bracing.

The contract price shall include excavation; installation and removal of sheeting and bracing; removal of water from the excavation; disposal of surplus material from the excavation; and furnishing, placing and compacting the specified material required to replace the materials excavated.

### **502.2(c) Rock Excavation.**

Rock excavation shall be measured in the field and the volume in cubic yards shall be computed from those measurements. The vertical measurements shall extend from the surface of the rock to an elevation six (6) inches below the bottom of the pipe or structure; the horizontal measurements shall be limited to the outside width of the pipe or structure plus two (2) feet. Boulders one-half (1/2) cubic yard or more in volume shall be measured individually and the volume of each boulder computed from average dimensions taken in three directions.

Rock excavation for sewer access structures shall be determined by the size of the sewer access structure to be installed. The vertical measurement shall extend from the surface of the rock to an elevation of eight (8) inches below the outside of the sewer for sewer access structures up to ten (10) feet deep and twelve (12) inches below the outside of the sewer for sewer access structures over ten (10) feet deep. The horizontal measurements shall be limited to the outside dimension of the sewer access structure plus two (2) feet.

The contract price shall include excavation of the rock; disposal of surplus material from the excavation; replacement with approved material of any shortage of backfill material resulting from rock excavation; and all other work incidental to rock excavation.

502.2(d) Removal of Excess Amounts of Boulders.

When it is deemed, by the Engineer, that the amount of boulders encountered on a sewer project are excessive, then the Contractor shall be paid six dollars (\$6.00) per cubic yard of boulders hauled from the project and disposed of by the Contractor. This shall not relieve the Contractor from any responsibility to remove, at no expense to the City, a usual amount of boulders; pay rock excavation; pay size boulders; and other excess materials from the project; as more fully described herein.

502.2(e) Dewatering.

All costs associated with TYPE I Dewatering shall be considered incidental to the project. TYPE II Dewatering shall be measured and paid by the lump sum for the completed work.

502.2(f) Bedding of Sewer Pipes.

The cost of bedding, including excavation for bedding material and bedding material furnished and compacted in place, shall be included in the unit price bid for sanitary and storm sewer pipe laid complete.

502.2(g) Select Backfill for Sewer.

Select Backfill for Sewer shall be measured by length in feet, measured along the centerline of the trench, for each type of sewer pipe specified. The quantity of Select Backfill for Sewer to be paid for shall not include materials excavated as part of this contract.

The contract price shall include furnishing, hauling, placing and compacting the specified material; and disposal of surplus material from the excavation displaced by the Select Backfill for Sewers.

502.2(h) Additional Fill for Embankments Over Sewers.

Additional fill for embankments over sewers shall be measured in cubic yards based on tickets received by the Engineer for each load of additional fill material. Payment for additional fill will not be made for any additional fill not substantiated by a ticket received by the Engineer.

The contract price shall include furnishing, hauling, placing and compacting the additional fill material; and all other work incidental to the installation of additional fill for embankments over sewers.

502.2(i) Tunneling and Jacking Sewer Pipe.

The measurement and payment for tunneling and jacking operations shall be in accordance with the Special Provisions covering such work in the contract.

502.2(j) Utility Trench Patches.

Utility trench patches shall be measured by length in feet, measured along the centerline of the trench as measured at the road surface, or by area in square yards for each type of patch installed.

The contract price shall include furnishing all materials necessary to restore the pavement, but shall not include the Select Fill material required to backfill the trench; and includes placing, consolidating

## Part V - Sewers and Sewer Structures

and compacting the materials used to restore the pavement; full depth sawcuts, tie bars and dowel bars and all other work incidental to the installation of utility trench patches.

## **ARTICLE 503 - SANITARY SEWER PIPES AND LATERALS**

---

### **503.1 Description.**

Unless otherwise shown on the plans or specified in the contract, the materials furnished and installed in the work shall conform to the requirements specified herein for the type and class of material named.

Unless otherwise directed by the Engineer, all pipe and accessories shall be unloaded at the point of delivery, and hauled to and distributed at the site of the work by the Contractor. The materials shall at all times be handled with care to avoid damage. The material shall not be dropped or bumped against the ground, other pipe and accessories already on the ground, or any other object on the ground.

The Contractor shall furnish random lengths of pipe for each contract as may be required for the proper placement of fittings or structures. The costs of random lengths of pipe shall be included in the contract unit prices for the respective sizes and types of pipe.

Unless otherwise specified, references to various standard specifications and test methods shall be understood to mean the specification or test method which is current on the date of advertisement for bids.

### **503.2 Materials.**

When plastic pipe of any type is used, the plastic pipe manufacturer shall be one whose pipe and joint have been accepted for use in Wisconsin by the Municipal Wastewater Section of the Department of Natural Resources. All pipe and fittings used on a project shall be supplied by the same manufacturer and shall be of the same type.

#### **503.2(a) Solid-Wall Poly (Vinyl Chloride) (PVC) Sewer Pipe and Fittings.**

Solid-Wall Poly (Vinyl Chloride) (PVC) sewer pipe and fittings, labeled as "PVC" on the plans, shall conform to the requirements of the Specification for Type PSM Poly (Vinyl Chloride) (PVC) Sewer Pipe and Fittings, ASTM D 3034, SDR-35 or SDSR-26. Joints shall be elastomeric or solvent cement and shall be made as recommended by the manufacturer.

#### **503.2(b) Corrugated-Wall Poly (Vinyl Chloride) (PVC) Sewer Pipe and Fittings.**

Corrugated-Wall Poly (Vinyl Chloride) (PVC) Sewer Pipe and Fittings, labeled as "CW PVC" on the plans, shall conform to the requirements of the Specification for Poly (Vinyl Chloride) (PVC) Corrugated Sewer Pipe with a Smooth Interior and Fittings, ASTM F 949. Joints shall be elastomeric or solvent cement and shall be made as recommended by the manufacturer. Each saddle (or wye) shall be attached to the sewer main with solvent cement and two stainless steel bands.

#### **503.2(c) Corrugated-Wall Polypropylene (CWPP) Sewer Pipe and Fittings.**

##### Dual Wall Polypropylene Pipe (CWPP 12" diameter- 30" diameter)

The polypropylene compound shall be an impact modified copolymer and shall conform to the specifications in this subsection. Twelve (12) through thirty (30) inch diameters shall meet all the requirements of ASTM F2736 Standard Specifications for Polypropylene (PP) Dual Wall Pipe and

Fittings. The pipe shall consist of smooth interior with annular exterior corrugations and have a minimum pipe stiffness of 46 pii. Pipe Joints shall be water-tight per ASTM F 2736 for twelve (12) through thirty (30) inch diameters. Water tight joints shall meet a 10.8 laboratory test per ASTM D 3212 and utilize a bell and spigot design with a gasket meeting ASTM F 477. Fittings supplied by manufacturers other than the supplier of the pipe shall not be permitted without the approval of the Engineer.

Triple Wall Polypropylene Pipe (CWPP 30”diameter- 36” diameter)

The polypropylene compound shall be an impact modified copolymer and shall conform to the specifications in this subsection. Thirty six (36) through Sixty(60) inch diameters shall meet all the requirements of ASTM F2764 Standard Specifications for Polypropylene (PP) Triple Wall Pipe and Fittings. The pipe shall consist of smooth interior and exterior surfaces with annular inner corrugations and have a minimum pipe stiffness of 46 pii. Pipe Joints shall be water-tight per ASTM F 2764 for thirty six (36) through sixty (60) inch diameters. Water tight joints shall meet a 10.8 laboratory test per ASTM D 3212 and utilize a bell and spigot design with a gasket meeting ASTM F 477. Fittings supplied by manufacturers other than the supplier of the pipe shall not be permitted without the approval of the Engineer.

Fittings for Polypropylene Pipe

Fitting for Polypropylene sanitary sewer shall be produced from the same material as the pipe by the same manufacturer. Nyloplast PVC fittings and adapters and Insert-A-Tee products specifically manufactured for use with Polypropylene Sanitary Sewer are also acceptable. All fittings shall be water-tight per ASTM D3212.

503.2(d) Poly (Vinyl Chloride) Pressure Pipe.

Pressure pipe and fittings, labeled as “PVC PRESSURE” on the plans, shall conform to the requirements of AWWA Standard for Poly (Vinyl Chloride) (PVC) Pressure Pipe and Fabricated Fittings, four (4) inches through twelve (12) inches, for Water Distribution, Pressure Class 150 (DR 18), AWWA C900. The joints shall be integral bell with elastomeric gaskets, or couplings with elastomeric gaskets.

The fittings for PVC pressure pipe shall conform to the requirements of American National Standard for Ductile-Iron and Gray-Iron Fittings, three (3) inch through forty-eight (48) inch, for Water and Other Liquids, ASA A21.10 (AWWA C110).

503.2(e) Reinforced Concrete Pipe.

The pipe, fittings, and accessories, labeled as “RCP” on the plans, shall be of reinforced concrete and shall conform to the requirements of the Specification for Reinforced Concrete Culvert, Storm Drain, and Sewer Pipe, ASTM C 76. Unless otherwise specified, sewer pipe shall be Class III (ASTM C 76).

Joints for sanitary sewer pipe shall be designed for the use of confined “O”-ring type rubber gaskets.

**503.2(f) Sanitary Lateral Electronic Markers.**

Effective Dec. 31, 2006, Act 425, Chapter 182.0175 (2r) of the Wisconsin State Statutes requires that all non-metallic building sewers (including sanitary laterals, private sanitary sewers and storm sewer laterals) installed within the City Right of Way, shall be accompanied by a means of locating the newly installed underground pipe. Sewer mains that have manhole or inlet structures on both ends within the City Right of Way are considered exempt from this legislation.

The City of Madison has selected a marker system that includes the installation of extended range ball markers over the sanitary sewer facilities, which after construction provide a signal that can be located by the city's utility locator after construction is complete.

The 3M ScotchMark Electronic Ball Marker System Extended Range Marker (model #1404-XR) [http://solutions.3m.com/wps/portal/3M/en\\_US/Locating-Marking-NA/Home/Product-Catalog/~/3M-EMS-4-Extended-Range-5-Ball-Marker-Wastewater-1404-XR?N=3293951336+4294891068&rt=d](http://solutions.3m.com/wps/portal/3M/en_US/Locating-Marking-NA/Home/Product-Catalog/~/3M-EMS-4-Extended-Range-5-Ball-Marker-Wastewater-1404-XR?N=3293951336+4294891068&rt=d) shall be considered an acceptable marker device for this specification. If an alternate equivalent marker is selected, contractor shall provide specifications and data sheets of the selected device to City Engineering prior construction in order for the City to confirm that the proposed marker device is compatible with the City's marking equipment.

**503.2(g) Sanitary Sewer Force Main Location.**

Effective Dec. 31, 2006, Act 425, Chapter 182.0715(2r) of the Wisconsin State Statutes requires that all non-metallic building sewers (including sanitary laterals, private sanitary sewers and storm sewer laterals) installed within the City Right of Way, shall be accompanied by a means of locating the newly installed underground pipe. All new force mains (pressure sewer systems) installations shall be in accompanied by a location system which shall consist of marker balls on a fixed horizontal location schedule per the below requirements.

**503.3 Construction Methods.**

**503.3(a) General.**

Whenever shown on the plan, or directed by the Engineer, the Contractor shall install sanitary sewer main, laterals, build wyes into the sanitary sewer mains for the installation of sanitary sewer lateral connections, and set risers into wyes.

**503.3(b) Laying Pipe.**

The pipe, fittings and accessories shall be of the size, class, type, and design; and shall be laid at the locations and to the required lines and grades; all as shown on the plans, required by the contract, or directed by the Engineer. Wherever the word "pipe" appears in this Subsection, it shall be understood to include pipe, fittings, and accessories.

The proper installations of structures and fittings, whose locations are shown on the plans and laid out by the Engineer shall be accomplished by the use of random lengths of pipe furnished by the Contractor. All field cuts of all types of pipe, except reinforced concrete pipe, shall be made with an approved mechanical pipe cutter or with a power saw in order to make a straight, true cut without chipping and cracking the pipe. In the event the Contractor is unable to obtain a certain size pipe, as specified on the plans or in the contract, the Contractor shall promptly inform the Engineer, and with

In such case, the additional cost resulting from such substitution shall be at the Contractor's expense and no adjustment in compensation will be allowed.

A flexible watertight connections shall be used for plastic sewer pipe connections to structures as detailed in Standard Detail Drawing 5.7.31, Flexible Pipe to SAS Connector. For concrete pipe connections, a mechanical vibrator shall be used during placement of the concrete collar to assure complete exterior seal of concrete pipes to the new structure.

The laying of pipes in finished trenches shall commence at the lowest point and shall proceed towards the upper end, and the pipe shall be laid so that the spigot or tongue ends point in the direction of flow.

Jointing surfaces shall be carefully cleaned before pipes are lowered into trenches. The pipes shall be lowered so as to avoid unnecessary handling in the trench. Each section shall have a firm bearing throughout its length and shall be true to the line and grade required.

The method of shoving or pulling the pipes together shall be such that there will be no injury to the pipes, and the joints will be properly adjusted and will not be excessively large. The pipes shall be fitted and matched so that when set firmly to line and grade they will form a sewer with a smooth and uniform invert.

After the pipe is installed, lift holes shall be sealed with suitable concrete or other approved plugs.

The pipe shall not be laid within ten (10) feet of the excavating nor within forty (40) feet of blasting operations. The pipe shall not be laid in water or on frozen trench bottoms, or when, in the opinion of the Engineer, the trench conditions or weather are unsuitable for the proper performance of the work.

No length of pipe shall be laid until the previously laid length of pipe has been sufficiently backfilled to hold it securely in place during the jointing operation. If, in making a joint, any previously laid pipe is disturbed, such pipe shall be removed and relaid. Adequate backfill shall be placed on the pipe to prevent floating. Any pipe which has been floated shall be removed and relaid at the expense of the Contractor.

The Contractor shall furnish suitable lifting and handling devices designed to distribute the weight of the pipe over the length of the pipe and prevent high stresses over small areas.

All water must be kept out of the bell hole of the pipe until the joint is completed and water shall not be allowed to rise in or about the pipe until the trench is filled at least one (1) foot above the top of the pipe.

Before leaving the work for the night, or during a storm, or for any reason, care must be taken that the unfinished end of the sewer is securely closed with a tightly fitting iron or wooden plug. Any earth or other materials that may find entrance into the sewer shall be removed by the Contractor at no additional cost to the City.

### 503.3(c) Sanitary Sewer Laterals.

#### 1. General.



## Part V - Sewers and Sewer Structures

Installation of sanitary sewer laterals shall comply with all the requirements set forth herein for the installation of the sewer main, including excavation, backfilling, bedding, laying and jointing pipe. Sanitary sewer laterals shall be laid with a maximum grade of one-half (1/2) inch per foot and a minimum grade of one-fourth (1/4) inch per foot. Unless otherwise specified, sanitary sewer laterals shall be of the same material as the sewer main pipe. Where laterals are to be connected to risers the Contractor shall furnish and install the required fittings.

The typical locations of sanitary sewer laterals to be installed in new developments are detailed in Standard Detail Drawing 5.3.2, Location of Sanitary Laterals. A separate sanitary sewer lateral shall be installed between the public sewer main and the property line to each unit of a split two-family dwelling (i.e., duplex unit).

For reconstruction of existing sanitary sewer, the connection of a lateral to a new structure shall be completed under Sanitary Tap and to a new main under Reconnect. For those laterals to be reconnected to a main, the first five (5) feet of the lateral and backfill from the main shall be included in the Reconnect and shall not be included in this item. The trench shall be backfilled with select backfill and shall be completed under Select Backfill for Sewers.

For laterals that are in close proximity to terrace trees (as determined by the Engineer), the situation shall be reviewed on a case by case basis by the Engineer and the City Forester. The Contractor shall use construction methods and equipment to minimize tree damage as directed by the Engineer and in accordance with section 107.13 Tree Protection Specification. In extreme cases the Engineer may elect to terminate lateral installation prior to conflict with the tree.

The estimated location of the laterals will be marked by the City of Madison on the sidewalk; however, Contractors are encouraged to start at the sanitary main. If the Contractor elects to start at the property line, it shall be at their own risk. No Utility Line Openings will be granted for the inability to locate the lateral at the property line.

Prior to the abandonment of any lateral, the Contractor shall definitively prove to the satisfaction of the Construction Engineer that the lateral is not currently in use and has no potential future use. The state of the lateral shall be determined by dye testing, the use of a push camera, the use of Sonde equipment, or other equipment that will determine where the lateral terminates. Lamping the lateral will only be an acceptable method if a cap or plug is visible.

### 2. Size.

When the lateral size is not specified, the following guidelines shall be used:

- For the installation of new lateral in the public right-of-way, unless otherwise specified in the plans or directed by the Engineer, the size of a newly constructed sanitary sewer lateral to be installed between the public sanitary sewer main and the property line shall be four (4) inches in diameter. The Engineer may require the size of the lateral to be six (6) inches or greater depending on the lot size or proposed land use.
- For the reconstruction, repair or replacement of sanitary sewer laterals in the public right-of-way, unless otherwise specified in the plans, when a portion of a sanitary sewer lateral in the public right-of-way is to be reconstructed, repaired or replaced, the inside diameter of the new lateral to be installed shall match that of the lateral which is being replaced. For purposes of this requirement, all five (5) inch laterals shall be considered to be six (6) inches in diameter.

It shall not be permissible, in any event, to decrease the diameter of a sanitary sewer lateral in the direction of flow.

3. Alignment.

Where a sanitary sewer lateral is being relaid in the public right-of-way and bends are required to reconnect the new lateral to the ends of the existing lateral or sewer main, the Contractor may use standard Poly (Vinyl Chloride) (PVC) bends that provide a change in the direction of flow of 22.5 degrees or less. Bends placed in a lateral shall be separated by straight pieces of pipe such that any two bends are separated by a distance of two (2) feet or more, measured from the center of each bend. The use of 45 degree bends shall be allowed only in connecting to a 45 degree wye at the sewer main in order to orient the lateral perpendicular to the sewer main.

4. Couplings.

Where a lateral is being relaid in the public right-of-way and connected to pipes of differing materials and/or sizes, couplings (SDD 5.3.3) shall be used. The couplings to be used shall provide for a tight fit around the outside diameter of each pipe and shall be securely fastened with two stainless steel clamps at each pipe end. Couplings which reduce the pipe cross sectional area in the direction of the flow shall not be allowed.

5. Reconnect.

Reconnect shall include reconstructing sanitary sewer lateral connections that shall be reconnected to the sanitary sewer main. This item shall include necessary wyes or fittings and PVC pipe, 4" or larger, for the connection of the lateral and shall not exceed a length of five (5) feet. All new laterals shall be a minimum of four (4) inches in diameter. Under no circumstances shall the new lateral be smaller than the existing. **Plugging the existing lateral,** select backfill and bedding required for the reconnection are included in this item. Sewer laterals that are to be reconnected to new sewer access structures shall be completed as a Sanitary Tap as specified in Subsection 507.3(d) – Sewer Connections. The Contractor shall be responsible for maintaining the normal flow of wastewater during reconnection of the laterals.

6. Sanitary Lateral Electronic Markers.

Each sanitary lateral shall have a minimum of 2 electronic markers: one shall be located above the wye on the sewer main and one shall be located above the lateral at the property line. Additional markers shall be placed at each change in horizontal direction. Markers shall be installed per manufacturer's written instruction. The key constraint is the maximum depth of the marker. The signal range of the 3M™ Electronic Marker System (EMS) 4" EXTENDED RANGE 5' BALL MARKER - WASTEWATER (MODEL 1404-XR) is 5 feet.

The City shall provide the Contractor with the required number of electronic markers for City bid public works contracts. The Contractor shall be responsible for picking up the markers at the Engineering Service Building, 1602 Emil Street in Madison, Wisconsin.

Upon completion, the City will test each electronic marker to confirm that it is installed and functioning properly. If it is determined that the marker has not been installed correctly and/or is not functioning properly, the contractor will be responsible for the all work associated with the installation of a properly functioning marker.

Sewer access structures are required on the City's sanitary sewer main on every instance that a lateral diameter is 8" or larger or if the proposed lateral size is of equal or larger size than the City's sanitary sewer main.

503.3(d) Sanitary Sewer Wyes.

Unless otherwise specified, the openings in the wyes for lateral connections and riser pipes shall be of the same size as the sanitary sewer lateral to be installed. In the event that a sanitary sewer lateral is not being installed coincident with the wye, the size of the wye shall meet the sizing requirements set forth for sanitary sewer laterals in Subsection 503.3(c) - Sanitary Sewer Laterals of these Specifications.

All wyes shall be of the same material as the sewer main. When the sewer main is constructed of Poly (Vinyl Chloride) (PVC) sewer pipe, the wyes shall be injection molded Poly (Vinyl Chloride) (PVC) wyes installed along with the sewer main construction. At the discretion of the Engineer, the use of saddle type wyes installed along with the sewer lateral construction may be permitted when the sewer main is constructed of Poly (Vinyl Chloride) (PVC) sewer pipe. All saddle type wyes for Poly (Vinyl Chloride) (PVC) sewer pipe installations shall be manufacturer's approved and shall be attached to the sewer main with a rubber gasket, solvent cement and two stainless steel clamps.

Wye openings, except those that are to be used for riser connections, shall be closed watertight with covers of the same material as the wye, well cemented in. When wyes are set in concrete encased pipe lines, their locations shall be marked by iron rods set in the concrete so that the rods shall project at least six (6) inches above the top of the encasement.

503.3(e) Sanitary Sewer Risers.

The top of riser pipes shall be brought to a point between nine (9) and ten (10) feet below the proposed finished street grade. The method as shown on Standard Detail Drawing 5.3.1, Riser Detail shall be indicated on the plans or by the engineer.

Unless otherwise specified, the riser pipes shall be of the same size and material as the sanitary sewer lateral to be installed. In the event that a sanitary sewer lateral is not being installed coincident with the riser pipe, the size of the riser pipe shall meet the sizing requirements set forth for sanitary sewer laterals in Subsection 503.3(c) - Sanitary Sewer Laterals of these Specifications.

For those instances in which a sanitary lateral is not being installed coincident with the riser pipe, a vertical reinforcing rod, one-half (1/2) inch in diameter, shall be strapped to the riser pipe and extended to within eighteen (18) inches of the proposed finished street grade for the case of future location by the City. In backfilling the trench, special care must be used at the location of riser pipes to tamp the backfill material about the entire length of the risers in such a way as to maintain them in a vertical position and not to disturb them.

503.3(f) Joints.

1. New Pipe to New Pipe.

Jointing materials shall conform to the requirements specified in Section 503.2 – Materials of these Specifications, for the type of pipe being installed.

Joints shall not be made until the pipe is in the trench and set to true line and grade. Lengths of pipe which are joined together outside of the trench shall be removed from the project immediately.

Prior to making joints, the jointing surfaces shall be inspected for chips, cracks, or other defects in the joints and jointing materials. The jointing surfaces shall be carefully cleaned and lubricated with a vegetable lubricant or a lubricating adhesive. Lubricant shall be applied to both the bell and spigot surfaces of the joint. The lubricant shall be that recommended by the gasket manufacturer for the particular type of gasket being installed.

Care shall be taken when shoving or pulling the pipes together in order not to damage the pipe or the joints and jointing materials. The pipes shall be in proper alignment and to the proper grade prior to applying the pressure necessary to make the joint.

Rubber gaskets for reinforced concrete storm sewer pipe shall be assembled as follows:

1. When air temperature is below 32°F, gaskets shall be applied one and one-half (1-1/2) hours before installation of the pipe.
2. When air temperature is above 32°F, gaskets shall be applied fifteen (15) minutes before installation of the pipe.

The temperature referred to pertains to the prevailing air temperature at the point of application of the gaskets. This shall be taken to mean the air temperature, either indoor or outdoor, at the time and place the gaskets and cement are being applied to the pipe. It does not refer to the temperature in the trench, or of the bonding cement, or of the pipe.

In making mechanical joints, the bolts shall be installed with the heads in reverse direction. The nuts shall be turned on only as far as they can be by using the wrench with one hand, with no extensions on the wrench to give greater leverage. Care shall be taken not to over-tighten the bolts. The bolts shall be tightened equally and diametrically in order to apply the proper pressure on the gasket and joint.

2. New Pipe to Existing Pipe.

A coupling shall be required at the junction of a new pipe to an existing pipe as specified on the plan set or as required in the field by the Engineer. It is expected that the Contractor shall saw cut the existing main at the location shown to accommodate a clean joint for the installation of the compression couplings. If the Contractor for his/her convenience deems it more suitable to remove the existing pipe to a full joint, the additional pipe required to connect the new pipe is to be the Contractor's responsibility and shall not be compensated. The coupling shall be placed as shown on the plan or as directed by the Engineer and shall be constructed per Standard Detail Drawing 5.3.3, Coupling Details.

503.3(g) Wastewater Control.

Wastewater Control shall include all equipment, labor, materials, coordination, and incidentals required to control or divert, to the Engineer's satisfaction, sanitary sewer flows during reconstruction of the sanitary sewer. This shall include pumps with adequate capacity of 100 g.p.m. and all associated equipment required to maintain a functioning sanitary sewer system during

construction. At no time shall the normal flow of wastewater in sanitary sewer service laterals be disrupted without prior approval from the Engineer. This condition shall also hold at the time of connection of an existing lateral to the new sewer main.

If the Contractor elects to use bypass pumping as a means of wastewater control, the methods, equipment, type of hose, etc. shall be subject to approval by the Engineer. Hoses crossing streets, driveways, parking areas, etc., are to be ramped over to prevent damage to hoses. Spillage of wastewater is to be contained within the trenches and disposed of downstream to previously installed sewer piping. No spillage of wastewater to adjacent streets, lawns, etc. shall be tolerated. If any such spillage should occur, all construction operations shall cease. Cleanup shall commence immediately and be completed to the satisfaction of the Engineer prior to the resumption of any construction operations.

503.3(h) Sanitary Sewer Force Main Tracer **Location**.

All new sanitary sewer force mains (pressure sewer mains) shall have marker balls (to be provided by the City) installed in accordance with the following.

A marker ball shall be installed in the trench immediately above the sanitary sewer main at a depth measured from the finish grade that does not exceed four (4) feet. The marker balls shall be installed on a maximum of 25 feet increments and at all horizontal bends in the pipe, and at all air vents or other structures installed on the line.

**503.4 Measurement and Payment.**

503.4(a) Sanitary Sewer Pipes.

Sanitary sewer pipes shall be measured to the nearest whole foot of each of the various types, classes and sizes of pipe installed at the various depths, measured along the centerline of the pipe center to center of junctions and fittings. The quantity to be paid for includes construction through sewer access structures, from center of sewer access structure casting to center of sewer access structure casting. Main extensions continuing through sewer access structures shall be measured from center of sewer access structure casting to the end of pipe. There shall be no deductions from the measured lengths for wye installations.

The contract price shall include furnishing all materials, including wyes, necessary to perform the work; excavation of the trench, except tunneling and jacking; installation and removal of sheeting and bracing; disposal of surplus material from the trench; backfilling the trench and compaction of the backfill material; embankment over the sewer using surplus material from the excavation of the trench; bedding the pipe; laying the pipe and installing the fittings and accessories; jointing and sealing of joints in pipe, fittings and accessories; encasement, where specified; connections to new structures; cleaning out the sewer; restoring the site; and all other work incidental to the installation of sanitary sewers.

503.4(b) Sanitary Sewer Laterals.

1. Laterals.

Sanitary sewer laterals shall be measured by length in feet of each of the various types, classes and sizes of pipe installed, measured along the centerline of the pipe from the wye opening to the end of the lateral pipe, or from the top of the riser to the end of the lateral pipe, whichever the case may be.

The contract price shall include furnishing all materials, including required fittings where laterals are connected to risers, necessary to perform the work; excavation of the trench; installation and removal of sheeting and bracing; backfilling the trench; and compaction of the backfill material; bedding the pipe; laying the pipe and installing the fittings; jointing and sealing of joints in pipe and fittings; encasement, where specified; cleaning out the lateral; restoring the site; and all other work incidental to the installation of sanitary sewer laterals.

Where the water service is installed in the same trench as the sanitary sewer lateral, the Contractor shall backfill the sanitary sewer lateral trench to the proper elevation for the installation of the water service; after installation of the water service, the Contractor shall complete the backfilling of the trench, all at no extra cost to the City. The labor, materials and tools necessary to make the taps, lay the water services and set the valve boxes shall be furnished by either the Water Utility or the Contractor, as specified in the contract.

2. Reconnect.

Reconnect shall be measured and paid as each reconstruction is completed and accepted and shall include necessary fittings and PVC pipe, 4" or larger, for the connection of the lateral and shall not exceed a length of five (5) feet. If the lateral replacement exceeds a length of five (5) feet, the quantity of pipe in excess of five (5) feet shall be paid for under the corresponding sanitary sewer lateral bid item.

3. Sanitary Lateral Electronic Markers.

Sanitary Lateral Electronic Markers shall be measured by each properly installed and functioning marker. No additional compensation will be provided for additional markers installed at the same location. The contract price shall be full payment for all work, materials (except electronic markers supplied by the City of Madison) and incidentals required to complete the work in accordance with the description. The Contractor shall be responsible for picking up the markers at the Engineering Service Building, 1602 Emil Street in Madison, Wisconsin.

503.4(c) Sanitary Sewer Risers.

1. Riser Detail.

Measure and pay for Riser Detail per section 503.4(b).

2. Alternate Method A & B.

Sanitary sewer risers shall be measured by length in vertical feet of each of the various types and sizes installed, measured from the invert of the sewer main to the top of the riser.

Part V - Sewers and Sewer Structures

The contract price shall include furnishing all materials, including fittings, necessary to perform the work; concrete encasement, including any additional excavation required; special backfilling precautions as specified; and all other work incidental to the installation of risers.

503.4(d) Joints.

All new pipe to new pipe joints shall be included in the sewer item as specified in Section 503.4 – Measurement and Payment. Compression Couplings required for new pipe to existing pipe joints shall be measured and paid as each completed unit as installed in the field.

503.4(e) Wastewater Control.

Wastewater control shall be measured and paid by the lump sum for the completed work.

## **ARTICLE 504 - STORM SEWER PIPES, APRON ENDWALLS AND OTHER STORM WATER CHANNELS**

---

### **504.1 Description.**

Unless otherwise shown on the plans or specified in the contract, the materials furnished and installed in the work shall conform to the requirements specified herein for the type and class of material named.

Unless otherwise directed by the Engineer, all pipe and accessories shall be unloaded at the point of delivery, and hauled to and distributed at the site of the work by the Contractor. The materials shall at all times be handled with care to avoid damage. The material shall not be dropped or bumped against the ground, other pipe and accessories already on the ground, or any other object on the ground.

The Contractor shall furnish random lengths of pipe for each contract as may be required for the proper placement of fittings or structures. The costs of random lengths of pipe shall be included in the contract unit prices for the respective sizes and types of pipe.

Unless otherwise specified, references to various standard specifications and test methods shall be understood to mean the specification or test method which is current on the date of advertisement for bids.

Other storm water channels include flumes and drainage ways. Flumes are further detailed in the Standard Detail Drawings. Drainage ways consist of small ditches to large scale greenways. Construction of drainage ways shall be done so in accordance with Article 200 – Earthwork. Typical greenway cross sections are included as Standard Detail Drawing 5.4.11, Typical Greenway Section (Grassed-flowline) and Standard Detail Drawing 5.4.12, Typical Greenway Section (Stabilized-flowline).

### **504.2 Materials.**

When a material type is not specified and a pipe is called out as a “Storm Sewer Pipe” on plans and specifications, the pipe supplied shall be of a type of pipe as follows excluding metal storm pipes.

All pipe and fittings not covered by this specification shall be approved by the Engineer seven (7) days prior to the bid letting.

#### **504.2(a) Reinforced Concrete Pipe.**

Reinforced concrete pipe, fittings, and accessories, labeled as “RCP” on the plans, shall conform to the requirements of the Specification for Reinforced Concrete Culvert, Storm Drain, and Sewer Pipe, ASTM C 76. Reinforced concrete elliptical pipe, fittings and accessories, labeled as “HERCP” on the plans, shall conform to the requirements of the Specification for Reinforced Concrete Elliptical Culvert, Storm Drain, and Sewer Pipe, ASTM C 507. Unless otherwise specified, reinforced concrete culvert and storm drain shall be Class III (ASTM C 76) and reinforced concrete elliptical culvert and storm drain shall be Class HE-III (ASTM C 507).

Joints for storm sewer pipe shall be designed for the use of rubber gaskets, flexible plastic gaskets, cold plastic sewer joint compound, external sealing bands, or a combination of the above. Unless otherwise specified, circular reinforced concrete pipe shall be installed with rubber gasket joints,



flexible plastic gaskets, cold plastic sewer joint compound, external sealing bands, or a combination of the above, at the Contractor's option.

Rubber gaskets shall conform to the requirements of the Specification for Joints for Circular Concrete Sewer and Culvert Pipe, Using Rubber Gaskets, ASTM C 443. Flexible plastic gaskets shall conform to the requirements of the Specification for Joints for Circular Concrete Sewer and Culvert Pipe Using Flexible Watertight Gaskets, Type B Flexible Plastic Gaskets, AASHTO M 198. Cold plastic sewer joint compound shall be SealTight Cold Plastic Sewer Joint Compound as manufactured by W.R. Meadows, Inc., or approved equal. External sealing bands shall be Mac Wrap External Joint Collars as manufactured by Mar-Mac Manufacturing Company, Inc., or approved equal.

504.2(b) Corrugated Polyethylene with Smooth Inner Liner Pipe.

High density polyethylene corrugated exterior/smooth interior pipe shall conform to the specifications in this Subsection. Four- through ten-inch diameters shall meet all the requirements of Specification for Corrugated Polyethylene Drainage Tubing, 3- to 10-Inch Diameter, AASHTO M252, Type S, with the addition that the pipe have a smooth interior liner. 12 to 60 inch diameters shall conform to ASTM F2306. The pipe shall consist of a corrugated exterior and an essentially smooth interior wall.

Pipe joints shall meet ASTM 2306 as water tight. Water tight joints shall meet a 10.8 laboratory test per ASTM D 3212 and utilize a bell and spigot design with a gasket meeting ASTM F477.

Fittings supplied by the manufacturers other than the supplier of the pipe shall not be permitted without the approval of the Engineer.

504.2(c) Corrugated Polyvinyl Chloride Pipe.

The thermoplastic material shall be a rigid PVC (polyvinyl chloride) plastic and shall meet or exceed the Specifications for Rigid Poly (Vinyl Chloride) (PVC) Compounds and Chlorinated Poly(Vinyl Chloride) (CPVC) Compounds, ASTM D1784, for a minimum cell classification of 12454B or 1245C. The fittings shall be made of PVC plastic having a cell classification of 12454B, 1245C, or 13343C as defined in ASTM D1784.

Gasketed pipe joints shall show no leakage when tested in accordance with ASTM D3212. Elastomeric seals (gaskets) shall meet the requirements of ASTM Specification F477. Joints shall meet soil tightness requirements of AASHTO 26.4.2.4(e).

PVC sewer pipe shall be manufactured per Specifications for Poly (Vinyl Chloride) (PVC) Corrugated Sewer Pipe with a Smooth Interior and Fittings, ASTM F949-93A with a minimum pipe stiffness (tested in accordance with ASTM D2412) of 50 psi. There shall be no evidence of splitting, cracking, or breaking when pipe is tested in accordance with ASTM D2412 at 60 percent flattening. Pipe dimensions shall meet the requirements given in ASTM F949-93a when measured in accordance with ASTM D2122.

504.2(d) Annular Corrugated Profile Wall Polyethylene Pipe.

High Density Polyethylene corrugated exterior/smooth interior pipe shall conform to the specifications in this Subsection. 2 to 60 inch diameters shall conform to ASTM F2648/ F2648M.

The pipe shall consist of a corrugated exterior and an essentially smooth interior wall. Pipe joints shall meet ASTM F2648 as water tight. Water tight joints shall meet a 10.8 laboratory test per ASTM D 3212 and utilize a bell and spigot design with a gasket meeting ASTM F477. Fittings supplied by the manufacturers other than the supplier of the pipe shall not be permitted without the approval of the Engineer.

**504.2(e) Polypropylene Corrugated Pipe with Smooth Inner Liner Pipe.**

The polypropylene compound shall be an impact modified copolymer and shall conform to the specifications in this subsection. Twelve (12) through thirty (30) inch diameters shall meet all the requirements of ASTM F2736 Standard Specifications for Polypropylene (PP) Corrugated Pipe. The pipe shall consist of a smooth interior with a corrugated exterior and have a minimum pipe stiffness of 46 psi. Pipe Joints shall be water-tight per ASTM F2736 for twelve (12) through thirty (30) inch diameters. Water tight joints shall meet a 10.8 laboratory test per ASTM D 3212 and utilize a bell and spigot design with a gasket meeting ASTM F477. Fittings supplied by the manufacturers other than the supplier of the pipe shall not be permitted without the approval of the Engineer.

**504.2(f) Poly (Vinyl Chloride) Pressure Pipe.**

Pressure Pipe shall conform to the requirements of American Water Works Association (AWWA) C905 Standard for Poly (Vinyl Chloride) (PVC) Pressure Pipe and Fabricated Fittings, four (4) inches through twelve (12) inches, for Water Distribution, Pressure Class 150 (DR18), AWWA C900. The joints shall be integral bell with elastomeric gaskets, or couplings with elastomeric gaskets. The fittings for PVC pressure pipe shall conform to the requirements of American National Standard for Ductile-Iron and Gray-Iron Fittings, three (3) inch through forty-eight (48) inch, for Water and Other Liquids, ASA A21.10 (AWWA C110).

**504.2(g) Triple Walled Polypropylene Pipe.**

The polypropylene compound shall be an impact modified copolymer and shall conform to the specifications in this subsection. Thirty six (36) through Sixty(60) inch diameters shall meet all the requirements of ASTM F 2764 Standard Specifications for Polypropylene (PP) Triple Wall Pipe and Fittings. The pipe shall consist of smooth interior and exterior surfaces with annular inner corrugations and have a minimum pipe stiffness of 46 pii.

Pipe Joints shall be water-tight per ASTM F 2764 for thirty six (36) through sixty (60) inch diameters. Water tight joints shall meet a 10.8 laboratory test per ASTM D 3212 and utilize a bell and spigot design with a gasket meeting ASTM F 477.

Fittings supplied by manufacturers other than the supplier of the pipe shall not be permitted without the approval of the Engineer.

**504.2(h) Solid-Wall Poly (Vinyl Chloride) (PVC) Sewer Pipe and Fittings.**

Solid-Wall Poly (Vinyl Chloride) (PVC) sewer pipe and fittings, labeled as "PVC" on the plans, shall conform to the requirements of the Specification for Type PSM Poly (Vinyl Chloride) (PVC) Sewer Pipe and Fittings, ASTM D 3034 for SDR-26. Joints shall be elastomeric or solvent cement and shall be made as recommended by the manufacturer.

Fittings supplied by manufacturers other than the supplier of the pipe shall not be permitted without the approval of the Engineer.

504.2(i) Storm Sewer Wyes, Tees, Angle-Sections, and Other Special Precast Sections.

Whenever shown on the plans, or directed by the Engineer, the Contractor shall furnish and install elbows, tees, wyes, reducers, or other prefabricated fittings for reinforced concrete pipe or corrugated metal pipe sewer installation. Fittings shall conform to Subsection 504.2(a) - Reinforced Concrete Pipe and Subsection 504.2(e) - Corrugated Metal Pipe. Elbows shall be fabricated to a tolerance of five (5) degrees, plus or minus of the angle of intersection (I) shown on the plans.

504.2(j) Concrete Apron Endwalls for Concrete Pipe Sewers.

Concrete Apron Endwalls for concrete pipe sewers, labeled as "RCP AE" on the plans, shall be manufactured with reinforcement and concrete conforming to the pertinent requirements for Class II, Wall B, reinforced concrete pipe as specified in the Specification for Reinforced Concrete Culvert, Storm Drain, and Sewer Pipe, ASTM C 76. Concrete Apron Endwalls for concrete elliptical pipe sewers, labeled as "HERCP AE" on the plans, shall be manufactured with reinforcement and concrete conforming to the pertinent requirements for Class HE-III reinforced concrete elliptical pipe as specified in the Specification for Reinforced Concrete Elliptical Culvert, Storm Drain, and Sewer Pipe, ASTM C 507. Apron endwalls shall be in accordance with the designs, dimensions, and details shown on the Standard Detail Drawing 5.4.1, Apron Endwalls for Pipes and Pipe Arches.

504.2(k) Metal Apron Endwalls for Corrugated Metal Pipe and Pipe-Arches.

Metal apron endwalls for corrugated metal pipe and pipe-arches shall be manufactured in accordance with the pertinent requirements specified in Subsection 504.2(e) - Corrugated Metal Pipe of these Specifications. Apron endwalls shall be in accordance with the designs, dimensions, and details shown on the Standard Detail Drawing 5.4.1, Apron Endwalls for Pipes and Pipe Arches.

504.2(l) Joint Ties.

Joint ties shall be installed on any pipe run beginning or ending in an apron endwall that is constructed with reinforced concrete pipe or horizontal elliptical reinforced concrete pipe of any size. Ties shall be installed at the endwall joint and at the last two (2) joints in accordance with designs, dimensions, and details shown on Standard Detail Drawing 5.4.6.

504.2(m) Storm Sewer Electronic Markers.

Storm Sewer Marker Disks shall be provided where non-metallic storm sewer pipe is installed in the public Right of Way, and where no access or inlet structures are available on the surface to allow the pipe to be visually located. Storm Sewer Electronic Markers shall meet the specifications of Article 503 for sanitary sewer.

504.2(n) Precast Reinforced Concrete Box Culvert.

All precast storm sewer boxes shall be constructed in accord with ASTM C-850.

### **504.3 Construction Methods.**

504.3(a) General.

504.3(b) Laying Pipe.

The pipe, fittings and accessories shall be of the size, class, type, and design; and shall be laid at the locations and to the required lines and grades; all as shown on the plans, required by the contract, or directed by the Engineer. Wherever the word “pipe” appears in this Subsection, it shall be understood to include pipe, fittings, and accessories.

The proper installations of structures and fittings, whose locations are shown on the plans and laid out by the Engineer shall be accomplished by the use of random lengths of pipe furnished by the Contractor. All field cuts of all types of pipe, except reinforced concrete pipe and corrugated metal pipe, shall be made with an approved mechanical pipe cutter or with a power saw in order to make a straight, true cut without chipping and cracking the pipe. In the event the Contractor is unable to obtain a certain size pipe, as specified on the plans or in the contract, the Contractor shall promptly inform the Engineer, and with the approval of the Engineer, the Contractor will be allowed to furnish and install a larger size pipe. In such case, the additional cost resulting from such substitution shall be at the Contractor’s expense and no adjustment in compensation will be allowed.

For concrete pipe connections, a mechanical vibrator shall be used during placement of the concrete collar to assure complete exterior seal of concrete pipes to the new structure as detailed in the Standard Detail Drawings. A flexible watertight connections shall be used for plastic sewer pipe connections to structures as detailed in Standard Detail Drawing 5.7.31, Flexible Pipe to SAS Connector.

The laying of pipes in finished trenches shall commence at the lowest point and shall proceed towards the upper end, and the pipe shall be laid so that the spigot or tongue ends point in the direction of flow.

Jointing surfaces shall be carefully cleaned before pipes are lowered into trenches. The pipes shall be lowered so as to avoid unnecessary handling in the trench. Each section shall have a firm bearing throughout its length and shall be true to the line and grade required.

The method of shoving or pulling the pipes together shall be such that there will be no injury to the pipes, and the joints will be properly adjusted and will not be excessively large. The pipes shall be fitted and matched so that when set firmly to line and grade they will form a sewer with a smooth and uniform invert.

After the pipe is installed, lift holes shall be sealed with suitable concrete or other approved plugs.

The pipe shall not be laid within ten (10) feet of the excavating nor within forty (40) feet of blasting operations. The pipe shall not be laid in water or on frozen trench bottoms, or when, in the opinion of the Engineer, the trench conditions or weather are unsuitable for the proper performance of the work.

No length of pipe shall be laid until the previously laid length of pipe has been sufficiently backfilled to hold it securely in place during the jointing operation. If, in making a joint, any previously laid pipe is disturbed, such pipe shall be removed and relaid. Adequate backfill shall be placed on the

pipe to prevent floating. Any pipe which has been floated shall be removed and relaid at the expense of the Contractor.

The Contractor shall furnish suitable lifting and handling devices designed to distribute the weight of the pipe over the length of the pipe and prevent high stresses over small areas.

All water must be kept out of the bell hole of the pipe until the joint is completed and water shall not be allowed to rise in or about the pipe until the trench is filled at least one (1) foot above the top of the pipe.

Before leaving the work for the night, or during a storm, or for any reason, care must be taken that the unfinished end of the sewer is securely closed with a tightly fitting iron or wooden plug. Any earth or other materials that may find entrance into the sewer shall be removed by the Contractor at no additional cost to the City.

#### 504.3(c) Joints.

The joint ties shall be installed in accordance with the Standard Detail Drawing 5.4.6, Concrete Pipe Joint Ties.

The following outlines specifications for new pipe to new pipe and new pipe to existing pipe connections.

##### 1. New Pipe to New Pipe.

Jointing materials shall conform to the requirements specified in Section 504.2 – Materials of these Specifications, for the type of pipe being installed.

Joints shall not be made until the pipe is in the trench and set to true line and grade. Lengths of pipe which are joined together outside of the trench shall be removed from the project immediately.

Prior to making joints, the jointing surfaces shall be inspected for chips, cracks, or other defects in the joints and jointing materials. The jointing surfaces shall be carefully cleaned and lubricated with a vegetable lubricant or a lubricating adhesive. Lubricant shall be applied to both the bell and spigot surfaces of the joint. The lubricant shall be that recommended by the gasket manufacturer for the particular type of gasket being installed.

Care shall be taken when shoving or pulling the pipes together in order not to damage the pipe or the joints and jointing materials. The pipes shall be in proper alignment and to the proper grade prior to applying the pressure necessary to make the joint.

Rubber gaskets for reinforced concrete storm sewer pipe shall be assembled as follows:

- When air temperature is below 32°F, gaskets shall be applied one and one-half (1-1/2) hours before installation of the pipe.
- When air temperature is above 32°F, gaskets shall be applied fifteen (15) minutes before installation of the pipe.

The temperature referred to pertains to the prevailing air temperature at the point of application of the gaskets. This shall be taken to mean the air temperature, either indoor or outdoor, at the time and place the gaskets and cement are being applied to the pipe. It does not refer to the temperature in the trench, or of the bonding cement, or of the pipe.

In making mechanical joints, the bolts shall be installed with the heads in reverse direction. The nuts shall be turned on only as far as they can be by using the wrench with one hand, with no extensions on the wrench to give greater leverage. Care shall be taken not to over-tighten the bolts. The bolts shall be tightened equally and diametrically in order to apply the proper pressure on the gasket and joint.

2. New Pipe to Existing Pipe.

A concrete collar or compression coupling shall be required at the junction of a new pipe to an existing pipe as specified on the plan set or as required in the field by the Engineer. The joints shall be clean and may require sawcutting the existing pipe for a clean edge. If the Contractor for his/her convenience deems it more suitable to remove the existing pipe to a full joint, the additional pipe required to connect the new pipe is to be the Contractors responsibility and shall not be compensated.

The concrete collar shall be constructed per Standard Detail Drawing 5.4.5, Concrete Collar and may include a change in horizontal or vertical direction. The compression coupling shall be constructed per Standard Detail Drawing 5.3.3, Coupling Details and shall not include a horizontal or vertical deflection between the two pipes.

504.3(d) Storm Sewer Electronic Markers.

Storm Sewer Electronic Markers shall comply with 503.3(c)6.

504.3(e) Storm Sewer Electronic Markers.

Storm Sewer Electronic Markers shall be paid in accord with 503.4(b)3.

504.3(f) Precast Box Culvert.

The Contractor shall be responsible for all work and coordination necessary to provide, coordinate deliver, unloading and other incidentals associated with the box culvert installation.

1. The sub-grade for the boxes shall have WDOT TYPE HR filter fabric placed on all exposed sub-grade areas prior to placement of the bedding stone for the boxes.
2. One (1) foot of three (3) inch clear stone shall then be placed on the geotextile fabric as bedding stone. Three (3) inch clear stone for box culvert bedding is included in the price of box culvert installation.
3. Pipe backfill above the bedding stone shall be in accord with SDD 5.2.2
4. The joints of the box culvert shall be sealed with seal-tight across the inside bottom and up the entire length of the inside vertical walls. Sealwrap shall be placed across the outside top of the box and completely down the outside vertical sides of the box. Provision and installation of all joint material is included in the price of the box culvert.

#### **504.4 Measurement and Payment.**

##### **504.4(a) Storm Sewer Pipes/Boxes.**

Storm sewers shall be measured to the nearest whole foot of each of the various types, classes and sizes of pipe installed at the various depths, measured along the centerline of the pipe center to center of junctions and fittings. The quantity to be paid for includes construction through sewer access structures, catchbasins, inlets and other structures, from center of structure casting to center of structure casting. The quantity to be paid for does not include the lengths of apron endwalls. There shall be no deductions from the measured lengths for the installations of wyes, tees, angle-sections and special sections required to join pipes of dissimilar sizes, shapes and types.

The contract price shall include furnishing all materials necessary to perform the work, including fittings and accessories, but not including wyes, tees, angle-sections and special precast sections required to join pipes of dissimilar sizes, shapes and types and apron endwalls; excavation of the trench, except tunneling and jacking; installation and removal of sheeting and bracing; disposal of surplus material from the trench; backfilling the trench and compaction of the backfill material; embankment over the sewer using surplus material from the excavation of the trench; bedding the pipe; laying the pipe and installing the fittings, accessories, wyes, tees, angle-sections and special sections; jointing and sealing of joints in pipe, fittings, wyes, tees, angle-sections and special sections; encasement, where specified; connections to new structures; cleaning out the sewer; restoring the site; and all other work incidental to the installation of storm sewers.

##### **504.4(b) Storm Sewer Wyes, Tees, Angle-Sections, and Other Special Precast Sections.**

Storm sewer wyes, tees, angle-sections, and other special precast sections required to join pipes of dissimilar sizes, shapes, and types shall be measured separately as units of each of the various sizes and types of each installed.

The contract price shall include the additional cost per wye, tee, angle-section or other special precast section over the cost of the sewer main. All costs of installing wyes, tees, angle-sections and other special precast sections shall be included in the contract prices for the sewer main.

##### **504.4(c) Apron Endwalls.**

Apron endwalls shall be measured separately as units of each of the various types, classes and sizes of each installed.

The contract price shall include furnishing all materials necessary to perform the work; excavation; installation and removal of sheeting and bracing; disposal of surplus material from the excavation; backfilling the excavation and compaction of the backfill material; embankment over apron endwalls using surplus material from the excavation; bedding the apron endwalls, laying the apron endwalls; jointing and sealing of joints between storm sewer pipes and apron endwalls; encasement, where specified; cleaning out the apron endwalls; restoring the site; and all other work incidental to the installation of apron endwalls.

504.4(d) Joints.

All new pipe to new pipe joints shall be included in the sewer item as specified in Section 504.4 – Measurement and Payment.

Concrete Collars required for new pipe to existing pipe joints shall be measured and paid as each completed unit as installed in the field. Concrete collars shall not be measured as a separate item when included in another item such as a Storm Sewer Tap. This item shall only be measured and paid where specifically called for in the plan or as needed to resolve unforeseen circumstances encountered in the field.

Compression Couplings required for new pipe to existing pipe joints shall be measured and paid as each completed unit as installed in the field.

Joint ties required for apron endwalls as specified in Subsection 504.2(i) – Joint Ties of these Specifications shall be considered as incidental to the cost of the apron endwall. All other joint ties shall be measured and paid for each joint requiring ties.

504.4(e) Tracer Wire & Box.

Tracer Wire & Box shall be paid in accord with 503.4(b)3.



## **ARTICLE 505 - BOX CULVERTS AND WINGWALLS**

---

### **505.1 Description.**

Unless otherwise shown on the plans or specified in the contract, the materials furnished and installed in the work shall conform to the requirements specified herein for the type and class of material named.

Unless otherwise directed by the Engineer, all box culverts and accessories shall be unloaded at the point of delivery, and hauled to and distributed at the site of the work by the Contractor. The materials shall at all times be handled with care to avoid damage. The material shall not be dropped or bumped against the ground, other materials and accessories already on the ground, or any other object on the ground.

Unless otherwise specified, references to various standard specifications and test methods shall be understood to mean the specification or test method which is current on the date of advertisement for bids.

### **505.2 Materials.**

#### **505.2(a) Box Culverts.**

Box culverts shall be precast reinforced concrete box sections, labeled as "RCBOX" on the plans, shall conform to the requirements of the Specification for Precast Reinforced Concrete Box Sections for Culverts, Storm Drains, and Sewer, ASTM C 1433.

#### **505.2(b) Joint Material.**

The joints of the box culverts shall be sealed with a combination of cold plastic sewer joint compound and external sealing bands.

Cold plastic sewer joint compound shall be SealTight Cold Plastic Sewer Joint Compound as manufactured by W.R. Meadows, Inc., or approved equal. External sealing bands shall be Seal Wrap External Joint Collars as manufactured by Mar-Mac Manufacturing Company, Inc., or approved equal.

### **505.3 Construction Methods.**

#### **505.3(a) Box Culverts.**

The Contractor shall abide by the following guidelines when installing box culverts:

1. The subgrade for the boxes shall have riprap filter fabric placed on all exposed subgrade areas prior to placement of the bedding stone for the boxes.
2. Eight (8) inches of three (3) inch clear stone shall be placed as bedding stone.
3. Box backfill shall be completed with select fill as specified. Compaction shall be required in eight (8) inch maximum lifts. Providing and placing of the select fill follow the requirements of Article 502 – Trench Excavation, Bedding, and Backfill.

4. The joints of the box culverts shall be sealed with a cold plastic sewer joint compound across the inside bottom and up two (2) feet on the vertical walls. The remainder of the box culvert joints shall be sealed with external sealing bands.

For multiple, parallel box installations, a three (3) inch horizontal separation shall be maintained between the boxes along the entire run. The void between the boxes shall be filled with TYPE A Slurry Mix as specified in Section 301.9 of these Specifications.

**505.3(b) Box Culvert Wingwalls.**

Box Culvert Wingwalls shall be constructed as depicted in Standard Detail Drawing 5.5.1, Box Culvert Wingwall, at the locations specified on the plan set.

**505.4 Measurement and Payment.**

**505.4(a) Box Culverts.**

Box Culvert shall be measured to the nearest whole foot of each of the various types, classes and sizes of box culvert installed at the various depths, measured along the centerline of the box culvert center to center of junctions and fittings. The quantity to be paid for does not include the lengths of wingwalls and construction through sewer access structures, catchbasins, or other structures. There shall be no deductions from the measured lengths for the installations of wyes, tees, angle-sections and special sections required to join boxes of dissimilar sizes, shapes and types.

The contract price shall include all materials necessary to perform the work, including fittings and accessories, but not including wyes, tees, angle-sections and special precast sections required to join pipes of dissimilar sizes, shapes and types and wingwalls; excavation of the trench, except tunneling and jacking; installation and removal of sheeting and bracing; disposal of surplus material from the trench; backfilling the trench and compaction of the backfill material; embankment over the sewer using surplus material from the excavation of the trench; laying the box; jointing material and sealing of joints in the box; filling the separation between multiple box installations; connections to existing structures; cleaning out the sewer; restoring the site; and all other work incidental to the installation of storm sewers.

Bedding including the required filter fabric and backfill with select backfill, if required, shall not be included in this item and shall be compensated under the respective items.

**505.4(b) Box Culvert Wingwalls.**

Box Culvert Wingwalls shall be measured and paid as each unit as completed and accepted in the field

The contract price shall include furnishing all materials necessary to perform the work; excavation; installation and removal of sheeting and bracing; disposal of surplus material from the excavation; backfilling the excavation and compaction of the backfill material; preparation of the foundation; construction of the structure, including connections; restoring the site; and all other work incidental to the installation of the box culvert wingwall.

## **ARTICLE 506 - STORM SEWER GATES**

---

### **506.1 Description.**

Storm Sewer Gates shall include steel gates to be installed on reinforced concrete pipe apron endwalls, reinforced concrete elliptical pipe apron endwalls, and box culvert wingwalls as specified in the plans.

### **506.2 Materials.**

#### **506.2(a) Storm Sewer Gates.**

Storm sewer gates for reinforced concrete pipe apron endwalls, labeled as “RCP AE GATE” shall be constructed per Standard Detail Drawings 5.6.1, RCP AE Gate and storm sewer gates for reinforced concrete elliptical pipe apron endwalls, labeled as “HERCP AE GATE” shall be of a similar construction. Storm sewer gates for the box culvert wingwalls shall be “INLET” or “OUTLET” gates and constructed as detailed in Standard Detail Drawing 5.6.2, Box Culvert Inlet Gate (Upstream) or Standard Detail Drawing 5.6.3, Box Culvert Outlet Gate (Downstream), respectively.

All storm sewer gates shall be painted as specified in Subsection 506.2(b), Structural Steel Paint-Epoxy System.

#### **506.2(b) Structural Steel Paint-Epoxy System.**

The following paint system shall be used on all storm sewer gates. At the discretion of the Contractor, a galvanized storm sewer gate may be provided. The galvanized gate shall conform to the specifications of the State of Wisconsin Standard Specifications for Highway and Structure Construction.

The Epoxy System shall consist of a prime or shop coat of organic or inorganic zinc-rich paint, an intermediate shop coat of high-build epoxy paint and a protective shop coat of urethane paint.

Structural steel which is to be welded shall not be coated before welding complete. If it is to be welded only in the fabricating shop and subsequently erected by bolting, it shall be given one coat of weldable primer or other approved protective coating after shop welding and shop fabrication is completed.

#### **1. Coating System.**

The Contractor shall select a complete coating system. The color of the epoxy shall be white and the urethane coating materials shall be a dark green. The Contractor shall supply the Engineer with the product data sheets before any coating is applied. The product data sheets shall indicate the mixing and thinning directions, the recommended spray nozzles and pressures, the minimum drying time for shop applied coats, the recommended procedures for painting zinc coated bolts, nuts and washers, the telephone number for technical service and other pertinent information.

#### **2. Organic or Inorganic Zinc Rich Primer.**

After the entire surface to be coated has been cleaned and approved by the Inspector, the primer shall be applied so as to produce a uniform even coating bonded to the metal.

The color of the primer must be such that a definite contrast which is readily apparent exists between it and the color of the blasted surface. The fabricator will be required to submit color samples of the primer to the Engineer for approval.

All areas shall have a minimum dry film thickness above the surface profile 0.076 mm (3.0 mils).

If the application of the coating at the required thickness in one coat produces runs, bubbles or sags, the coating shall be applied in two, wet, even coats using a fifty (50) percent overlap with minimum dry or overspray. Where excessive coating thickness produces mud-cracking, such coating shall be removed back to soundly bonded coating and the area recoated to the required thickness.

In areas of deficient primer thickness, the areas shall be cleaned thoroughly with power washing equipment as necessary to remove all dirt; the areas then shall be brushed with a non-rusting tool, vacuumed and recoated.

3. Epoxy System (Intermediate and Protective Coats).

On all areas the white intermediate coat shall have a minimum dry film thickness of 0.089 mm (3.5 mils) and the protective coat shall have sufficient thickness to provide a uniform color and appearance, but in no case less than 0.025 mm (1.0 mils).

**506.3 Measurement and Payment.**

Storm Sewer Gates shall be measured and paid as each unit of the various types, classes and sizes installed and accepted and shall include the fabrication, painting and installation of the gate.

## **ARTICLE 507 - SEWER STRUCTURES**

---

### **507.1 Description.**

Work under this section shall apply to sewer access structures, cleanouts, catchbasins and inlets for sanitary and storm sewer connections.

### **507.2 Castings.**

#### **507.2(a) General.**

Gray iron castings used in the work shall conform to the requirements of the Specifications for Gray Iron Castings, ASTM A 48, Class 30 except as noted.

The castings for sewer access structures, catchbasins, and inlets shall be in accordance with the designs, dimensions, and details shown on the Standard Detail Drawings for the installation named, unless otherwise specified. Frames and lids for sewer access structures and catchbasins shall be machined and fitted so that rocking and chattering will be eliminated. The lids installed on sanitary sewers shall have the self-sealing gaskets firmly glued in place at the factory. All cleanouts shall conform to the requirements in the Wisconsin Plumbing Code. The type of cleanout cap shall be approved in advance by the field engineer.

#### **507.2(b) Sewer Access Structures.**

The following lists of Neenah Foundry castings are acceptable for City construction and are further detailed in Standard Detail Drawing 5.7.16, SAS Frame and Cover. Substitutions shall be approved by the Engineer prior to delivery to the job site.

1. R-1550 Heavy-duty, w/logo lid 1550-0054, nine (9) inch high, non-rocking sewer access structure frame and Type "B" non-rocking self-sealing sewer access structure lids with concealed pick holes.
2. R-1689 Heavy-duty, w/logo lid 1550-0054, four (4) inch high, non-rocking sewer access structure frame and Type "B" non-rocking self-sealing sewer access structure lids with concealed pick holes.
3. R-1920 Heavy-duty, sewer access structure frame and self-sealing lid with Type "F" locks and concealed pick holes.

#### **507.2(c) 3'x3' Catchbasins.**

The following lists of Neenah Foundry castings are acceptable for City construction. Substitutions shall be approved by the Engineer prior to delivery to the job site.

1. R-1878-A10G Heavy-duty, four (4) inch high, catchbasin frame with open grate.
2. R-1878-A10L Heavy-duty, four (4) inch high, catchbasin frame with solid lid.
3. R-1879-A10F Light-duty, four (4) inch high, catchbasin frame with solid lid.

4. R-1879-A10L Light-duty, four (4) inch high, catchbasin frame with solid lid.

507.2(d) Inlets.

The following lists of Neenah Foundry castings are acceptable for City construction and are further detailed in the Standard Detail Drawings. Substitutions shall be approved by the Engineer prior to delivery to the job site.

1. R-3067 -7004 Heavy-duty curb inlet frame, curb box with two (2) inch radius and “Dump No Waste - Drains to Lake” logo.

**Grates: Neenah Foundry Type R, Type V, Type VB.**

For use with Type “H” Inlets in Type ‘A’, Type ‘B’ or Type ‘H’ Concrete Curb and Gutter.

2. R-3067 -7009 Heavy-duty curb inlet frame, slanted curb box with openings.

For use with Type “H” Inlets in Type ‘A’ Mountable Concrete Curb and Gutter.

**Note: Grates to be denoted in construction plans.**

3. R-3067-7000 Casting to be used when an existing “H” inlet is located at a new or proposed driveway location. In this application, the curb head section of the casting shall be removed from the existing inlet and replaced with this "plate" casting. This allows the existing inlet frame to be used without removal and replacement of the existing curb & gutter section surrounding the inlet to replace with our standard driveway casting R-3290-A.

**Note: Casting number provides frame and grate.**

4. R-3067-C Narrowed Casting (no casting in the curb head area) to be used as an alternate to R-3067-7000 in drive way areas.

**Note: Casting number provides frame and grate.**

5. R-3290 -A Heavy-duty curb inlet frame and custom grate. No curb box required. For use with Type “H” Inlets in Driveway Section Type ‘A’ Concrete Curb and Gutter.

**Note: Casting number provides frame and grate.**

6. R-1878 -B7G Heavy-duty frame and flat open grate for use with Type “H” Inlets and in grassed areas. No curb box required.

7. R-1878 -B7L Heavy-duty frame and flat closed cover for use with Type “H” Inlets. No curb box required.

8. R-3281-A Heavy-duty curb inlet frame, curb box with two (2) inch radius. May be used with diagonal openings grate denoted with **-AL** (left) or **-AR** (right) or with staggered longitudinal vane grate denoted with a **-B**. For use with Type “S” Inlets in Type ‘G’ Concrete Curb and Gutter.
9. **R-3362-L** Casting to be installed on inlets constructed in alleys with “v” style ribbon curb - see SDD 5.7.33 for installation details.
10. R-3808-0005 Component number for all version of Terrace Inlets (SDD 5.7.12) shall be made of DUCTILE IRON – this requires a special order from Neenah Foundry. Standard Gray Iron castings shall not be allowed for use.

#### 507.2(e) Special Castings

1. R-3262-2 Stormwater Curb Opening for 6” curb heads – this casting is used to allow the discharge of roof drains, sump pumps or small parking areas to the curb line where no storm sewer is available for connection.
2. R-3262-6 Stormwater Curb Opening for 9” curb heads – this casting can be installed as part of a terrace rain-garden/bioretenention system to take water from the curb line to the garden. Where this casting is used the flow-line of the curb shall be depressed 3 inches to direct the runoff from small events directly to the garden system.
3. R-3268 Stormwater Curb Opening for 8” curb heads – this casting can be installed as part of a terrace rain-garden/bioretenention system to take water from the curb line to the garden. Where this casting is used the flow-line of the curb shall be depressed 2 inches to direct the runoff from small events directly to the garden system. This casting shall be used when rain-garden/bioretenention systems are in areas with significant tree canopies.

### 507.3 Construction Methods.

#### 507.3(a) General.

The construction of concrete sewer access structures, catchbasins, and inlets shall conform to the pertinent portions of Part 3, Concrete and Concrete Structures of these Specifications, and the applicable Standard Detail Drawings for the structure involved. Sewer access structures, cleanouts, catchbasins and inlets shall be of a size and type specified in the contract, and shall be constructed at the location and to the elevation shown on the plans, or as directed by the Engineer. Cleanouts shall be constructed in accordance to the Wisconsin Plumbing Code.

Unless otherwise specified, all sanitary sewer access structures shall be constructed of precast units of reinforced concrete provided they meet all the precast requirements. Sewer access structures and inlets for storm sewers may be either cast-in-place or precast concrete structures. If the plans specifically require a field poured structure, then the structure shall be cast-in-place with no exception. If the structure is not specifically required to be field poured, a precast structure may be

substituted for a cast-in-place structure provided they meet all the precast requirements and approval is granted by the Engineer.

Cast-in-place structures shall be constructed as detailed in the Standard Detail Drawings. The bases of all structures which are cast-in-place shall be poured prior to pouring the walls of the structures, unless otherwise ordered or allowed by the Engineer.

For all cast-in-place structures constructed in greenways, retention basins, ponds and infiltration basins, XYPEX ADMIX C-500 shall be included in the concrete used for the construction of these structures. XYPEX ADMIX C-500 is a waterproofing agent. It is expected that structures this will affect include box culvert aprons, multiple cell pipe aprons, outlet structures, control structures, and other miscellaneous structures. Where this ADMIX is used the Contractor shall not be required to use epoxy coated rebar for the reinforcement within these structures. XYPEX ADMIX C-500 shall be used in the concrete mix at the ratio recommended by the manufacture and documentation of the ADMIX being included in the concrete mix shall be provided to the Construction Engineer.

Various layout requirements for storm sewer inlets are included in the Standard Detail Drawings.

#### 507.3(b) Precast Requirements.

Precast Sewer Access Structures (SAS) and inlets, generally referred to as precast structures, shall be of reinforced concrete and shall conform to the specifications of Precast Reinforced Concrete Manhole Sections, ASTM C 478. Joints shall meet the requirements for circular reinforced concrete pipe as specified in these Specifications.

Precast structures for storm sewer may be furnished with steps. Precast structures for sanitary may be furnished with steps in the barrel sections only. If steps are used in the cone sections to facilitate construction, they shall be removed prior to acceptance.

Precast structures of reinforced concrete may be substituted for cast-in-place structures provided they can meet all of the following criteria and the conditions of the contract and approval is granted from the Engineer. No precast structures shall be brought to the job site until approval is granted from the Engineer. Any precast structure not meeting these criteria shall be replaced by a cast-in-place structure or a precast structure satisfying these criteria at the Contractor's expense.

The following procedure shall be followed prior to approval of precast structures:

1. The Contractor shall complete all required utility line openings as detailed in Subsection 508.1(a), Utility Line Opening,
2. The Engineer will review the data provided and make any necessary design changes,
3. Upon completion of any redesign the Contractor shall make a request and submit shop drawings of any precast structures to the Engineer,
4. The Engineer shall have two (2) days to review the request and provide a decision to the Contractor.



## Part V - Sewers and Sewer Structures

The following precast requirements are specific for sanitary sewer and storm sewer precast structures.

### 1. Sanitary Sewer.

The following precast requirements shall be met for all precast SAS for sanitary sewers:

- Precast SAS shop drawings for public works reconstruction projects shall be approved prior to fabrication and delivery to the site.
- Precast SAS shop drawings for private developments are not required.
- Spreader bars shall be used if “lift eyes” are utilized for movement and placement of the precast structure.
- Each precast structure on the plan shall be custom manufactured with factory-made cores for sanitary sewer connections.
- The total height of adjustment shall be a minimum of three (3) inches and a maximum of nine (9) inches.
- The base shall be precast integral to the precast structure. The invert and bench may be either field poured concrete or precast and shall be such that the invert provides positive flow through the structure and the height of the bench shall match the top of the discharge pipe.

A base section with a precast bench and invert may be provided, subject to the following requirements:

- The concrete of all inverts shall be finished with a steel trowel to produce a smooth flowline. Inverts which are brushed and/or have a rough flowline may be rejected by the Engineer in the field.
- The Contractor shall provide for a tight joint between all pipes entering or leaving the structure and the precast invert such that there is no abrupt change in the grade of the flowline through the joint. Any grinding or grouting of the invert which is required to produce a tight joint shall be considered incidental to the installation of the precast structure.
- The precast bench shall extend to a height of 3/4 of the diameter of the pipe, at a minimum.
- All inlet flowlines shall be poured with gentle sweeps through the structure towards the outlet flowline such that cleaning and televising equipment can pass easily along the flowlines.

### 2. Storm Sewer.

The following precast requirements shall be met for all precast SAS for storm sewers:

- Pick holes on a barrel sections with no base shall be utilized with extreme care. Pick holes shall not be utilized as a method to place the bottom sections. Pick holes shall be sealed on the inside and the outside of the precast structure prior to backfilling the excavation.

## Part V - Sewers and Sewer Structures

- Each precast structure on the plan shall be custom manufactured with factory-made cutouts for storm sewer connections. Cutouts shall not extend into the groove of the bottom section or barrel section(s). There shall be a minimum of twelve (12) inches of the inside wall of the precast structure present between the cutouts for the pipes. A minimum of two (2) inches of the precast structure must be present between the top of the knockout and the bottom of the adjustment rings. No removal of the precast structure above the precast knockout will be allowed.
- The total height of adjustment shall be a minimum of three (3) inches and a maximum of nine (9) inches.
- The base shall be precast integral to the precast structure. The invert and bench may be either field poured concrete or precast and shall be such that the invert provides positive flow through the structure and the height of the bench shall match the springline of the discharge pipe.
- No drain holes shall be provided. This practice has been replaced with the use of underdrains. Reference Standard Detail Drawing 5.7.14, Underdrain, for the acceptable locations for underdrain connections.

The following requirements are specific to all precast inlets for storm sewers:

- Pick holes shall be sealed on the inside and outside of the precast inlet prior to backfilling of the excavation.
- Each precast inlet shall be custom manufactured with factory-made knockouts and/or cutouts. Factory stock inlets will not be accepted. A minimum of two (2) inches of concrete is required from the edge of the cutout measured horizontally to the inside edge of the inlet box. Maximum pipe sizes allowed when a precast inlet is used are: twenty-one (21) inch out of the three (3) foot side, and twelve (12) inch out of the two (2) foot side.
- The total height of adjustment shall be a minimum of 2 ¼ inches and a maximum of eight (8) inches.
- The base shall be precast integral to the precast structure. The inlet invert and bench shall then be field poured such that the invert provides positive flow through the structure and the height of the bench matches the invert elevation of the discharge pipe.
- If precast inlets with multiple knockouts are permitted by the Engineer, the Contractor shall be aware that any “dog house” areas of the structure which are not used to connect a pipe at the structure or any excess area of the “dog house” where a pipe is connected shall be filled with Grade “A” concrete such that the “dog house” area of the structure is flush with the outside wall of the inlet structure.

### 507.3(c) Castings.

Castings shall be installed to the grades shown on the plans or as directed by the Engineer. Sewer Access Structure (SAS) castings shall be installed 1/4 inch below the final grade. SAS castings that

are 3/4 inch, or more, below the final grade shall be repaired. Inlet castings shall be set to grade prior to and separate from the pouring of the concrete curb and gutter. It is expected and required that three (3) feet of concrete curb and gutter on either side of the inlet shall be poured by hand, not through the use of a curb machine. The inlet casting shall be set to grade on a bed of mortar, which shall be a minimum of 2-1/4 inches thick. The inlet shall be placed on the mortar bed and shall be adjusted to grade by applying direct pressure to the casting. Once the casting adjustment is complete, three (3) feet of curb and gutter on either side of the inlet casting shall be poured by hand. The inlets shall be placed in accord with the appropriate Standard Detail Drawing. The acceptable offset criteria are detailed in Standard Detail Drawing 5.7.29, Inlet Casting Offset Criteria for H Inlets. Unless otherwise specified, allowance shall be made for a nine (9) inch high catchbasin or sewer access structure frame and adjustment rings or blocks in accord with Standard Detail Drawing 5.7.5, 5.7.6, or 5.7.15, whichever is applicable. All frames and adjustment rings shall be constructed in accord with Standard Detail Drawings 5.7.5, 5.7.6, or otherwise secured as shown on the plan set. Solid concrete adjusting blocks or bricks may be substituted for precast adjusting rings in accord with Standard Detail Drawing 5.7.15, SAS Chimney and Casting. The mortar shall be air-entrained, type M or S. Any precast inlets or structures not meeting the casting grade requirements will not be accepted and shall be replaced with a cast-in-place structure or a precast structure meeting these specifications at the cost of the Contractor.

Internal Chimney Seals shall be installed on all sanitary sewer access structures located within 100 feet of a street low point, in greenways and where indicated on the plans or in the field. Internal chimney seals shall be either rubber with metal bands or a low density polyethylene insert conforming to Standard Detail Drawing 5.7.17 – SAS Internal Chimney Seal or other internal chimney seal products as approved by the Engineer.

Existing castings that conform to the Standard Specifications on the job site may be salvaged and reused on new structures for that project as approved by the Engineer. Otherwise, all excess salvaged castings shall be delivered to the Engineering Service Building as specified in Part II of these Specifications.

#### 507.3(d) Sewer Connections.

The connections of new pipes at new structures are detailed in the respective sewer type Sections with the exception of sanitary sewer drop inlets which are defined in this Subsection.

When a structure is to be constructed at an existing pipe, the Contractor shall sawcut the existing pipe in the required location to accommodate the placement of the new structure. If the Contractor deems it more suitable to remove the existing pipe to a full joint, the additional pipe and connection required to reconnect the sewer shall be the Contractor's responsibility.

The following requirements are specific for sanitary sewer and storm sewer connections.

##### 1. Sanitary Sewer.

Whenever shown on the plans, or directed by the Engineer, the Contractor shall install outside drop inlets in conjunction with the installation of sanitary sewer access structures as detailed in the Standard Detail Drawings. The pipe and fittings to be used in the construction of the outside drop inlets shall be of the same material as the sewer main. The pipe and fittings shall be securely anchored to the sewer access structure to prevent displacement during the placement of the concrete

encasement. Where allowed, an inside drop may be constructed as detailed in Standard Detail Drawing 5.7.30 - Inside Drop for Sanitary Lateral.

A Sanitary Sewer Tap shall include the connection of an existing lateral or main to a new structure. A coupling (SDD 5.3.3) shall be provided and used by the Contractor to connect the existing pipe to any new pipe that is required to make the connection to the structure as detailed in Standard Detail Drawing 5.7.31, Flexible Pipe to SAS connector. Any new pipe that is installed by the Contractor to reconnect the existing sewer main or lateral shall be considered incidental to this bid item. The newly installed pipe shall match the existing pipe's diameter or be of the next larger diameter. If the existing lateral is to be replaced, the new pipe shall be compensated under the corresponding sanitary sewer lateral bid item. The pouring and construction of concrete benches and flowlines in new sewer access structures for the inlet or outlet pipes shall not be considered a part of this work. The construction of concrete benches and flowlines shall be considered incidental to the installation of the sewer access structure. The downstream pipe connection to a Sewer Access Structure shall also be considered incidental to the Sewer Access Structure and not a tap connection regardless of whether the downstream sewer main is a proposed or an existing pipe connection. In the case of doghouse sewer access structure being approved to be constructed over an existing City sanitary sewer main, no sanitary taps will be granted for the host pipe being saddled over (upstream or downstream pipe connection).

The Contractor shall be responsible for maintaining the normal flow of wastewater during tapping of the sewer access structure.

Sewer access structures are required on the City's sanitary sewer main on every instance that a lateral diameter is 8" or larger or if the proposed lateral size is of equal or larger size than the City's sanitary sewer main.

## 2. Storm Sewer.

### **Storm Sewer Tap**

Shall include all work, materials and incidentals required to connect a new pipe of the size and type specified in the contract to an existing structure or pipe. The pipe being used shall be paid separately under the appropriate item. The new connection shall be made in a workmanship like manner to assure the structural integrity of the tapped structure or pipe once the connection is made. A Storm Sewer Tap/Connection shall be completed in accord with the type of pipe material being connected and the type of material being connected to.

### **Private Storm Sewer Reconnects**

**Type 1 Private Reconnect - shall include all work necessary to reconnect private storm sewer pipes to newly constructed storm sewer inlets or other structures. This bid item shall include all materials necessary to make the private storm sewer connection, including pipe and couplings as necessary. All pipe used in the reconnection of private storm sewer drains shall be either PVC or RCP material, and shall be similar in size to the existing private storm pipe, and shall be incidental to the work. Under no circumstances shall an existing, private storm sewer pipe be reduced in size. The Contractor shall not abandon any private storm sewer pipe without written approval of the property owner served by this pipe.**

Type 2 Private Reconnect - shall include all work necessary to reconnect private storm sewer pipes to newly constructed storm sewer inlets or other structures. This bid item shall include all materials necessary to make the private storm sewer connection, including pipe and couplings as necessary. Work under this bid item shall also include all work, materials, and incidentals necessary to reroute, from the property line, the private storm line, as shown on the plan set. Pipe bedding, select backfill, and any surface repairs required by the realignment, shall all be considered incidental to this bid item. All pipe used in the reconnection of private storm sewer drains shall be either PVC or RCP material, shall be similar in size to the existing private storm pipe, and shall be incidental to the work. Under no circumstances shall an existing, private storm sewer pipe be reduced in size. The Contractor shall not abandon any private storm sewer pipe without written approval of the property owner served by this pipe.

### New Pipe Connections

Where a new reinforced concrete pipe is being tapped into an existing concrete structure or pipe the connection shall be made in a workmanship like manner to assure the structural integrity of the tapped structure or pipe once the connection is made. It is required, and this item includes, the use and provision of a concrete collar to complete and seal the connection between the existing structure or pipe and the new pipe. The work completed shall be in accord with Standard Detail Drawing 5.7.32, Storm Sewer Tap Detail.

Where a new plastic pipe is being connected into an existing concrete pipe or concrete structure the contractor shall field core the existing structure or pipe and provide a Core-n-T, Core-n-Seal boot, or approved equal to connect the new pipe to the existing pipe or structure as detailed in Standard Detail Drawing 5.7.31, Flexible Pipe to SAS Connector. Where the connection is being made to an existing plastic pipe, a preformed fitting, from the manufacture of the existing plastic pipe, shall be utilized. The work under this item shall include all necessary work to provide the field core and all necessary fittings.

When a new private connection is being made to the public system all construction shall comply with the conditions above, and shall additionally utilize Table 3 - Private Connections to determine if a new structure rather than a tap/connection shall be required.

### 3. Removal and Replacement of Sanitary Sewer and/or Storm Sewer Connections in CIPP.

The contractor shall provide a watertight seal between the host pipe and the liner. Seals shall be made with an epoxy or resin mixture compatible with the liner/resin system. Hydraulic cements and quick-set cement products are not acceptable. The exposed liner shall be inserted into the new sanitary access structure and attached to the flexible watertight connections.

**TABLE 3**  
**Private Connections**

PIPE BEING CONNECTED		PIPE BEING CONNECTED TO		TYPE OF CONNECTION REQUIRED
SIZE	TYPE	SIZE	TYPE	
6"	PLASTIC	>= TO 12"	RCP/PLASTIC	TAP / FITTING
8" & 10"	PLASTIC	<= TO 12"	RCP/PLASTIC	STRUCTURE
8" & 10"	PLASTIC	> THAN 12"	RCP/PLASTIC	TAP / FITTING
12"	PLASTIC	<= TO 15"	RCP/PLASTIC	STRUCTURE
12"	PLASTIC/RCP	>= TO 18"	RCP/PLASTIC	TAP / FITTING
15"	PLASTIC/RCP	<= TO 21"	RCP/PLASTIC	STRUCTURE
15"	PLASTIC/RCP	> THAN 21"	RCP/PLASTIC	TAP / FITTING
18"	PLASTIC/RCP	<= TO 27"	RCP/PLASTIC	STRUCTURE
18"	PLASTIC/RCP	> THAN 27"	RCP/PLASTIC	TAP / FITTING
21"	PLASTIC/RCP	<= TO 30"	RCP/PLASTIC	STRUCTURE
21"	PLASTIC/RCP	> THAN 30"	RCP/PLASTIC	TAP / FITTING
>= TO 24"	PLASTIC/RCP	ANY SIZE	ANY TYPE	STRUCTURE

**NOTES:**

1. Only the following pipe types are allowed under the pavement structure of a public street. Pipe being installed from the back of curb into the pavement structure shall only be Reinforced Concrete Pipe (RCP), AWWA C-900 (commonly known as Blue Brute), Cast Iron or Ductile Iron. Effectively, this reduces plastic pipe connections to structures or pipes in the curb line or terrace.
2. Pipe installed from the back of curb toward the private property shall be approved "storm pipe" in accordance with Article 504.2 Storm Sewer Pipes, Apron Endwalls and Other Storm Water Channels.
3. Where any type of pipe is being connected to a horizontal elliptical pipe (HERCP) and that connection is not occurring with matching spring lines, a new structure shall be required for the connection. Further, if the pipe being connected to the existing HERCP has an inside diameter greater than one half the inside vertical diameter of the existing HERCP, a new structure shall be required for the connection.
4. Where any type of pipe is being connected to a box culvert a tap/connection may be utilized.
5. The method of connection to existing clay pipe, or any type of pipe not specifically discussed above shall be at the discretion of the Construction Engineer.

#### **507.4 Measurement and Payment.**

##### **507.4(a) Sanitary Sewer Access Structures.**

Sanitary sewer access structures shall be measured separately as units of each of the various types and sizes of each installed at the various depths. The depths of installation shall be measured in feet from the invert of the lowest outlet pipe to the bottom of the cast-iron sewer access structure frame.

The contract price shall include furnishing all materials necessary to perform the work, including castings unless specified to include a salvaged casting; excavation; installation and removal of sheeting and bracing; disposal of surplus material from the excavation; backfilling the excavation and compaction of the backfill material; preparation of the foundation; construction of the structure, including connections; cleaning out the structure; restoring the site; and all other work incidental to the installation of sanitary sewer access structures.

##### **507.4(b) Storm Sewer Access Structures, Catchbasins and Inlets.**

Storm sewer access structures, catchbasins and inlets shall be measured separately as units of each of the various types and sizes of each installed. Unless otherwise specified, thru sewer access structures shall be considered to be six (6) feet in length.

The contract price shall include furnishing all materials necessary to perform the work, including castings unless specified to include a salvaged casting; excavation; installation and removal of sheeting and bracing; removal of water from the excavation; disposal of surplus material from the excavation; backfilling the excavation; backfilling the excavation and compaction of the backfill material; preparation of the foundation; construction of the structure, reconnection of all existing pipes, connection of new pipes, including connections; cleaning out the structure; restoring the site; and all other work incidental to the installation of storm sewer access structures, catchbasins and inlets.

##### **507.4(c) Internal Chimney Seals.**

Internal Chimney Seals shall be measured as each unit installed.

The contract price shall include furnishing all materials, including required accessories, necessary to perform the work and work incidental to the installation of an internal chimney seal.

##### **507.4(d) Sanitary Drop Inlets.**

Outside drop inlets and inside drop inlets shall be measured by length in vertical feet of each inlet installed, measured from the invert of the entry tee to the springline of the sewer main.

The contract price shall include furnishing all materials, including required fittings and accessories, necessary to perform the work; concrete encasement required; cleaning out the inlet; and all other work incidental to the installation of outside drop inlets.

##### **507.4(e) Sewer Taps.**

Sanitary Sewer Taps and Storm Sewer Taps shall be measured as a completed unit as installed in the field.

Part V - Sewers and Sewer Structures

507.4(f) Sanitary Sewer Cleanouts.

Sanitary sewer cleanouts shall be measured as a completed unit as installed in the field.



## **ARTICLE 508 - UTILITY CROSSINGS**

---

### **508.1 Description.**

#### **508.1(a) Utility Line Opening.**

Utility Line Opening, ULO, shall include all work, materials, coordination, equipment, and incidentals required to locate and expose an existing utility at the location indicated on the plan and as directed in the field using open cut methods or vacuum technology.

##### **1. Open Cut Methods**

A single ULO shall include a trench up to a maximum of five (5) feet long, as measured at the trench bottom, and of any depth required to locate the intended utility. Multiple utilities may be uncovered with no additional compensation.

##### **2. Vacuum Technology**

A single ULO shall include the use of vacuum excavation investigation technology to locate the marked utility at its proposed / existing crossing with the City of Madison utility. Should the number of vacuum excavations exceed five (5) and the utility is still not located, a second ULO shall be paid by the City. Multiple utilities may be uncovered with no additional compensation.

Work shall be completed to locate the limits of the utility package including the top and bottom elevations and width of package as needed to complete contracted work.

The Engineer or his/her agent shall be notified of this work so that they may be present when the utility is exposed. The grades of the utility lines shall be determined by the Engineer, and the utility companies will be advised by the Engineer as to their adjustment required. The Contractor shall then backfill and maintain the openings. This work shall be completed a minimum of three (3) days prior to any work being anticipated in the immediate area of the ULO, to allow sufficient time for redesign of the affected utility if so required.

Work necessary to expose existing underground facilities that are part of the Contractor's statutory obligation during the normal storm sewer, sanitary sewer, electrical conduit or water main installation shall be considered as incidental to those respective items and will not be paid for as utility line openings.

Work to restore the site after completion of the ULO shall be the responsibility of the Contractor and is included in the price of this item.

The standard for restoration will vary project by project and be dependent on the relative time during the project that the ULO is completed. Regardless, it is the Contractor's responsibility to restore the ULO site to a safe condition commensurate with the condition of the construction site at the time the ULO is completed.

**508.1(b) Concrete Supports.**

Whenever shown on the plans, or directed by the Engineer, the Contractor shall install pipe supports in accordance with the Standard Detail Drawing 5.8.1, Concrete Supports. Pipe supports shall be installed under a new sewer pipe when such sewer pipe crosses over an existing utility line within twelve (12) inches.

**508.1(c) Reinforced Concrete Beam Support.**

Whenever shown on the plans, or directed by the Engineer, the Contractor shall install a utility line support, in accordance with the Standard Detail Drawing 5.8.2, Reinforced Concrete Beam Support. A beam support shall be installed under an existing utility line when a new sewer installation crosses under such utility line and the existing utility line is considered to be in danger of damage or failure.

**508.1(d) Encasement.**

Whenever shown on the plans, or directed by the Engineer, sewer pipes shall be concrete encased so that a thickness of six (6) inches of concrete surrounds the entire pipe, and the base width of the encasement is twelve (12) inches plus the outside diameter of the pipe from the earth foundation to the spring line of the pipe. The bottom of the encasement shall be a flat surface parallel to the grade of the sewer. The concrete used for encasement shall have a minimum compressive strength of 2,000 psi.

**508.1(e) Utility Crossing.**

When reviewing utility information for conflicts with proposed storm sewer, the design engineer will determine if there is sufficient clearance for the carrier pipe and the outside wall thickness excluding the bell. As the design engineer cannot be responsible for bell locations on the pipe run, adjustment of the pipe sections to avoid bells at the utility crossing shall be the responsibility of the Contractor. No additional compensation shall be provided to the Contractor for this adjustment and all necessary work to achieve this result shall be considered to be incidental to the Utility Line Opening.

**508.2 Measurement and Payment.**

**508.2(a) Utility Line Openings.**

A single ULO by open cut methods shall include a trench up to a maximum of five (5) feet long, as measured at the trench bottom, and of any depth required to locate the intended utility and may uncover multiple utilities. A single ULO by Vacuum Technology shall include up to five (5) vacuum excavations of any depth required to locate the intended utility and may uncover multiple utilities. The Contractor shall not be compensated more than once for a single utility line opening which uncovers multiple utilities provided the utilities are within the five (5) foot trench length as measured at the trench bottom or within five (5) vacuum excavations. The contract price shall include all work, materials, coordination, equipment, and incidentals required to locate and expose the utility at the location indicated on the plan and as directed in the field using open cut methods, backfill the excavation, compact the backfill material, restore and maintain the site as needed.

Where utility line openings are not listed as an item on which to submit unit prices, it shall be understood and agreed that the Contractor shall be paid three hundred dollars (\$300.00) up to six (6) feet in depth and (\$500) over six (6) feet in depth for each unit excavated and backfilled in accordance with these Specifications.

508.2(b) Concrete Supports.

Concrete supports shall be measured as a unit for support of the sewer pipe.

The contract price shall include furnishing all materials necessary to perform the work; excavation and disposal of surplus material from the excavation; constructing the pipe supports; and all other work incidental to the installation of pipe supports.

508.2(c) Reinforced Concrete Beam Support.

Reinforced concrete beam support shall be measured as each support installed.

The contract price shall include furnishing all materials necessary to perform the work; excavation and disposal of surplus material from the excavation; and all other work incidental to the installation of a reinforced concrete beam utility line support.

## ARTICLE 509 - CURED-IN-PLACE PIPE (CIPP) REHABILITATION OF SANITARY SEWERS

---

### 509.1 Description.

The work under this section provides for the trenchless rehabilitation of sanitary sewers by the installation of a Cured-in-Place Pipe (CIPP) within the existing, deteriorated pipe. The rehabilitation of the sanitary sewer main shall be done by the installation of a resin-impregnated flexible fabric tube which, when cured, shall be continuous and tight-fitting throughout the entire length of the original pipe and provide a structurally sound, jointless and water-tight new pipe within a pipe.

All live service connections shall be reinstated without excavation, utilizing a remote controlled cutting device, monitored by a video TV camera. Reinstated service connections shall be tested and sealed with a chemical grout designed to eliminate infiltration.

### 509.2 Referenced Documents.

This specification references ASTM standards and other related standards, which are made a part hereof by reference and shall be the *latest edition* thereof.

<u>ASTM Standard F 1216</u>	Practice for Rehabilitation of Existing Pipelines and Conduits by the Inversion and Curing of a Resin-Impregnated Tube
<u>ASTM Standard F 1743</u>	Practice for Rehabilitation of Existing Pipelines and Conduits by the Pull in and Inflate and Curing of a Resin-Impregnated Tube
<u>ASTM Standard F 2019</u>	Practice for Rehabilitation of Existing Pipelines and Conduits by the Pulled in Place Installation of Glass Reinforced Plastic (GRP) Cured-in-Place Thermosetting Resin Pipe (CIPP)
<u>ASTM Standard D 543</u>	Practices for Evaluating the Resistance of Plastics to Chemical Reagents
<u>ASTM Standard D 638</u>	Test Method for Tensile Properties of Plastics
<u>ASTM Standard D 790</u>	Test Methods for Flexural Properties of Unreinforced and Reinforced Plastics and Electrical Insulating Materials
<u>ASTM Standard D 903</u>	Test Method for Peel or Stripping Strength of Adhesive Bonds
<u>ASTM Standard D 1600</u>	Terminology for Abbreviated Terms Relating to Plastics
<u>ASTM Standard D 3567</u>	Practice for Determining Dimensions of "Fiberglass" (Glass-Fiber-Reinforced Thermosetting Resin) Pipe and Fittings
<u>ASTM D 3839</u>	Guide for Underground Installation of "Fiberglass" (Glass-Fiber Reinforced Thermosetting-Resin) Pipe
<u>ASTM Standard D 5813</u>	Specification for Cured-In-Place Thermosetting Resin Sewer Piping Systems
<u>ASTM Standard E 797</u>	Practice for Measuring Thickness by Manual Ultrasonic Pulse-Echo Contact Method
<u>ASTM Standard F 412</u>	Terminology Relating to Plastic Piping Systems
	National Association of Sewer Service Companies (NASSCO) "Recommended Specifications for Sewer Collection Rehabilitation"

### 509.3 Submittals.

The Contractor shall not install materials or equipment, which requires submittals, until reviewed by the Engineer. The Engineer's review will be completed as quickly as possible, but may require up to ten (10) working days from the date the submittals are received until they are sent to the Contractor.

The Contractor shall submit the following materials to the Engineer:

509.3(a) Product Data.

1. Manufacturer's product literature and application, installation and recommended repair (patching) requirements for materials used in liner.
2. Manufacturer's product certification of conformance to ASTM Standards for materials used in liner.
3. Manufacturer's Wet Out Report including raw resin data for each liner to be installed and the Manufacturer's recommended curing procedure.
4. Two (2) copies of Liner Pipe Thickness Design Calculations. The design calculations shall be in accordance with Appendix X.I of ASTM F 1216. The liner thickness calculations shall assume the physical properties stated in Section 509.5(d) of these specifications. Proposed CIPP flow capacity calculations.
5. Test results from previous field installations of the same resin system and tube materials as proposed for the actual installation.

No liner will be approved for installation until the City has returned one (1) set of approved design calculations to the Contractor.

Compensation for all work required for the submittal of product data shall be considered incidental to the project.

509.3(b) Digital Video.

1. Submit digital video of cleaned pipes in pre-lining condition.
2. Submit digital video of pipes in post-lining condition showing reinstated and grouted service connections.

509.3(c) Sewage Bypassing Plan.

Submit proposed plan for bypassing sanitary sewage during liner installation. Plan shall be to scale and shall show location of existing City sewer access structures.

509.3(d) Traffic Control Plan.

Submit proposed plan for Traffic Control during liner installation. Plan shall be to scale, shall show location of existing City sewer access structures, and be in accordance to the Contract document requirements.

509.3(e) Public Notifications.

Submit proposed public notification letter and door hangers. Notifications shall be in accordance to Section 509.4(e) Public Notification.

#### **509.4 Requirements of Contractor.**

##### **509.4(a) Safety.**

The Contractor agrees to perform all work under this contract in accordance with local, state and federal safety regulations. This includes, but is not limited to, evaluation of the atmosphere to determine the presence of toxic or flammable vapors or lack of oxygen prior to entering access areas such as sewer access structures and performing inspection or cleaning operations and the use of confined entry equipment for all entries.

##### **509.4(b) Bypassing Pumping.**

The Contractor shall provide for the continuous flow of sewage around the sections of sewer line designated for lining. A bypass shall be installed by plugging the line at an existing upstream sewer access structure and pumping or directing the flow to a downstream sewer access structure. The pump(s) and bypass lines shall be of adequate capacity and size to handle the flow. Raw sewage shall be routed back to the sanitary sewerage system or hauled and disposed of as approved by the City.

Bypass pumping shall be limited to the regular hours of work as provided by the City unless necessitated by an emergency beyond the Contractor's control. A representative of the Contractor must be on-site at all times that bypass pumping is in operation.

If the Contractor elects to use bypass pumping as a means of sewerage control, the methods, equipment, type of hose, etc., shall be subject to approval by the City Engineer. Hoses crossing streets, driveways, parking areas, etc., are to be ramped over to prevent damage to the hoses.

No spillage of wastewater to adjacent streets, lawns, etc., shall be tolerated. If any such spillage should occur, all construction operations shall cease and cleanup shall commence immediately and be completed to the satisfaction of the Engineer prior to the resumption of any construction operations.

Contractor shall familiarize himself with the City's sanitary sewerage facilities and develop an adequate bypassing plan. A written plan shall be submitted to the City Engineer for approval prior to the start of work.

##### **509.4(c) Water for Cleaning and Inversion/Installation of CIPP.**

The Contractor shall furnish water for cleaning and flushing the existing sewer pipe and for inversion and installation of the CIPP. Contractor shall obtain water from the City of Madison Water Utility. All hydrant use must be pre-approved by Madison Water Utility. Contractor shall obtain a permit from Madison Water Utility and shall properly utilize back-flow prevention and/or other hydrant access device supplied by and installed onto hydrant by Madison Water Utility. The Contractor shall pay all costs associated with coordinating and obtaining water for the cleaning, flushing and inversion operations, including the cost of any cold-weather insulation required at the hydrant access device.

**509.4(d) Disposing of Debris.**

Contractor shall be responsible for disposing of debris removed from sewers at a licensed disposal facility (i.e., Dane County Landfill or Madison Prairie Landfill). The Contractor shall pay all costs associated with the transport and disposal of such debris.

**509.4(e) Public Notification.**

Contractor shall make every effort to maintain service usage throughout the duration of the project. In the event that a service needs to be taken out of service, the maximum amount of time allowed for the service interruption shall be 8 hours for any property served by the sewer. The Contractor shall implement a public notification program that shall, at a minimum, require the Contractor to be responsible for contacting all tenants and owner of each home or business connected to the sanitary sewer and informing them of the work to be conducted and the date, time and length of service interruption.

The Contractor shall prepare and submit written notice describing the work to be performed for the Engineer to review. Upon acceptance by the Engineer, the notice shall be delivered to each home or business a minimum of seven (7) days prior to the beginning of work being conducted on the pipe section. Door hangers shall also be placed at effected properties between no later than 24 hours and no earlier than 72 hours prior to the sewer service interruption. All notices shall also contain a local (or toll free) telephone number of the Contractor that property owners can use to discuss the project or any problems that arise during installation of the liner. Contractor shall also arrange meetings with any occupants whose service cannot be reinstated within the time referenced in the written notice. Any related costs such as hotel expenses or residential bypass pumping are the responsibility of the Contractor.

The City shall provide the Contractor with names and addresses of effected property owners and tenants within the project limits.

**509.5 Materials.**

**509.5(a) General Requirements.**

The resins, fabric tube, tube coatings, or other materials shall produce CIPP that meets the requirements of these specifications.

All materials, shipped to the project site, shall be accompanied by test reports certifying that the material conforms to the ASTM standards listed herein. Each tube to be installed shall be accompanied by the manufacturer's Wet Out Report detailing the raw resin data and the recommended curing procedure. Materials shall be shipped, stored, and handled in a manner consistent with written recommendations of the CIPP system manufacturer to avoid damage. Damage includes, but is not limited to, gouging, abrasion, flattening, cutting, puncturing, or ultra-violet (UV) degradation. All damaged materials shall be promptly removed from the project site at the Contractor's expense and disposed of in accordance with all current applicable agency regulations

**509.5(b) Tube.**

For Heat Cure CIPP systems, the tube material shall meet the requirements of ASTM F 1216 and ASTM D5813, or better. The tube shall consist of one or more layers of flexible needled felt or an

equivalent nonwoven or woven material, or a combination of nonwoven and woven materials, capable of carrying resin, withstanding installation pressures and curing temperatures. The tube shall be compatible with the resin system used. The material shall be able to stretch to fit irregular pipe sections and negotiate bends. The outside layer of the tube shall be plastic coated with a material that is compatible with the resin system used. The tube shall be fabricated to a size that, when installed, will tightly fit the internal circumference and the length of the original conduit. Allowance shall be made for circumferential stretching during inversion.

Seams in the tube shall be stronger than the non-seamed material.

For Ultraviolet Light Cure CIPP systems, the tube material shall be made of non corrosion material and shall be free from tears, holes, cuts, foreign materials and other surface defects. The fiberglass tube shall be constructed to withstand installation pressures as required by the Manufacturer's recommendations. The interior and exterior foil shall be styrene resistant along with the ability to protect and contain the resin within the liner, with the exterior foil being impermeable to light. The liner should be seamless and spirally wound in its cured state to ensure homogenous physical properties around the circumference of the cured liner. The nominal fiberglass tube wall thickness shall be constructed to the nearest 0.5 mm increment, rounded up from the design thickness for that section of installed CIPP. The fiberglass tube shall be manufactured to a size that when installed will tightly fit the internal circumference and the length of the original conduit. The tube shall be able to stretch to fit irregular pipe sections and negotiate bends.

For any tube installed, the wall color of the interior pipe surface of CIPP after installation shall be a light reflective color so that a clear detailed examination with closed circuit television inspection equipment may be made.

#### 509.5(c) Resin.

For Heat Cured CIPP Systems, the resin system shall meet the structural and chemical resistance requirements of ASTM F 1216 and/or ASTM F 1743, or better. A general purpose, unsaturated, styrene-based, thermoset resin and catalyst system or an epoxy resin and hardener that is compatible with the inversion process shall be used. The resin must be able to cure in the presence of water and the initiation temperature for cure shall be less than 180°F (82.2°C).

For Ultraviolet Light Cure CIPP Systems, the resin used to impregnate the seamless fiberglass tube shall produce a cured liner pipe resistant to shrinkage, corrosion, and abrasion and shall have a proven resistance to municipal wastewater. The resin shall be a chemically resistant isophthalic based polyester thermoset resin and catalyst system, or epoxy resin and hardener that are compatible with the installation process. The resin should be able to cure with ultraviolet light. When properly cured the resin/liner system shall meet the structural and chemical resistance requirements of ASTM F 2019.

#### 509.5(d) Structural Requirements: Cured-in-Place Pipe (CIPP).

The required structural CIPP wall thickness shall be in accordance with the Design Equations in Appendix XI of ASTM F 1216 and based on the following physical properties:

- i) Existing pipe is a "fully deteriorated pipe"
- ii) Minimum ovality of host pipe shall be 5%
- iii) Enhancement factor (K) shall not be greater than 7.0



Part V - Sewers and Sewer Structures

- iv) Minimum design safety factor shall be 2.0
- v) Flexural modulus of elasticity shall be reduced by 50% to account for long term.
- vi) Creep retention factor 33%
- vii) Minimum service life 50 years

The CIPP design shall assume no bonding to the original pipe wall.

The Contractor must have performed long-term testing for flexural creep of the CIPP material installed by his/her Company. Such testing results are to be used to determine the long-term, time dependent flexural modulus to be utilized in the product design. This is a performance test of the materials (Tube and Resin) and general workmanship of the installation and curing. A percentage of the instantaneous flexural modulus value (as measured by ASTM D 790 testing) shall be used in design calculations for external buckling. The percentage, or the long-term creep retention value utilized, shall be verified by this testing. Values in excess of 50% shall not be applied unless substantiated by qualified third party test data. The materials utilized for the contracted project shall be of a quality equal to or better than the materials used in the long-term test with respect to the initial flexural modulus used in Design.

The bond between the layers of the cured CIPP shall be strong and uniform. It shall not be possible to separate any two layers with a probe or point of a knife blade so that the layers separate cleanly or the probe or knife blade moves freely between the layers. If separation of the layers occurs during testing of field samples, new samples will be cut from the work. Any reoccurrence shall cause rejection of the work.

Any layers of the tube that are not saturated with resin prior to insertion into the existing pipe shall not be included in the structural CIPP wall thickness computation.

The CIPP system shall have as a minimum the initial structural properties as listed below.

**TABLE 4: Minimum Physical Properties**

<b>Property</b>	<b>Test Method</b>	<b>Cured Composite (<i>min. per ASTM F1216</i>)</b>	<b>Cured Composite (<i>400,000 psi Resin</i>)</b>
Flexural Modulus	ASTM D-790	250,000 psi	400,000 psi
Flexural Strength	ASTM D-790	4,500 psi	4,500 psi

These physical strength properties shall be determined in accordance with Section 509.7.

**509.5(e) Grout: Chemical Grout to Seal Service Connections.**

The chemical grout shall be of a type, which has a documented record of satisfactory performance in sewer usage. All grouting materials shall be delivered to the job site in the original, labeled, and unopened containers.

The chemical grout(s) selected by the Contractor is/are subject to approval of the Engineer. Grouts shall be either 3M Scotch Seal #5619 Polyurethane, DeNeef Multigel Polyurethane, Avanti International AV118 Duriflex or approved equal.

509.5(f) Testing Requirements.

1. Chemical Resistance - The CIPP shall meet the chemical resistance requirements of ASTM F 1216. CIPP samples for testing shall be of the same tube and resin system as that proposed for actual construction. It is required that CIPP samples with and without plastic coating meet these chemical-testing requirements.
2. Hydraulic Capacity - The Contractor shall provide calculations that demonstrate that the liner pipe shall have at least 100% of full flow capacity of the original pipe before rehabilitation in a full gravity flow condition. Calculated capacities may be derived using a commonly accepted roughness coefficient for the original pipe material. A typical roughness coefficient of the liner pipe shall be as verified by third party test data.
3. Field Samples - The Contractor shall submit test results from previous field installations of the same resin system and tube materials as proposed for the actual installation. These test results must verify that the CIPP physical properties specified in Table 1 of 509.5(d) have been achieved in previous field applications.

**509.6 Construction Methods.**

509.6(a) Cleaning of Sewer Lines.

It shall be the responsibility of the Contractor to completely clean each sanitary sewer prior to lining. The work shall consist of providing all labor, materials, power, utilities and equipment necessary to thoroughly clean identified sewers and restore them to 95% of their original carrying capacity.

Sewer cleaning shall be conducted in accordance with "Recommended Specifications for Sewer Collection Rehabilitation," published by the National Association of Sewer Service Companies (NASSCO). Cleaning Equipment is to be truck-mounted combination jetter/vacuum machines able to thoroughly remove dirt, grease, roots, encrustations, rocks, sand and other materials and thoroughly clean the sewer lines prior to installation of the pipe liner. The cleaning equipment shall move debris to the downstream manhole of the line being cleaned. All material resulting from the cleaning operation shall be removed by vacuum at the downstream manhole of the section being cleaned. Passing material from manhole section to manhole section shall not be permitted. If any debris is passed downstream, the Contractor shall clean the affected section(s) of sewer main at no additional cost to the City.

It shall be the responsibility of the Contractor to clear the line of all obstructions such as solids or roots that can be removed by conventional sewer cleaning equipment. If inspection reveals an obstruction that cannot be removed by conventional sewer cleaning equipment, the Contractor shall immediately notify the Project Engineer. The Project Engineer shall determine if the obstruction is able to be removed by sewer cleaning equipment and, if not, if the particular section of main shall be repaired by the City or deleted from the contract. In the event the Engineer determines that a repair shall be made the contractor shall proceed with work on other sections of main and return to the obstructed main after the City has completed necessary repair(s). No additional compensation shall be made to the Contractor as a result of any delays necessitated by such repairs.

509.6(b) Inspecting and Televising Pipelines.

It is the responsibility of the Contractor to inspect all sanitary sewers to be lined using closed-circuit television prior to installation of the CIPP and again following the reinstatement and grouting of all service connections. Experienced personnel trained in locating breaks, obstacles, and service connections by closed circuit television shall perform inspection. The interior of the pipeline shall be carefully inspected to determine the location of any conditions that may prevent proper installation of the impregnated tube, such as protruding service taps, collapsed or crushed pipe, and significant reductions in the cross sectional area. The Contractor shall immediately notify the Project Engineer of any conditions that prevent the proper installation of the CIPP.

The Contractor shall utilize a closed-circuit television video system that is capable of capturing, producing and recording color digital video of the sewer inspection. The Contractor shall provide color digital video for each sanitary sewer segment designated by the project plans. The video system shall have the capability of capturing or transferring the color video to an MPEG digital format compatible with personal computers.

All inspections shall follow the Pipeline Assessment and Certification Program (PACP) protocol as established by the National Association of Sewer Service Companies (NASSCO). The inspecting, televising and video recording equipment used on the project shall be the Contractor's choice provided it meets the following minimum requirements:

- The camera, transporter and winch system shall have the ability to continuously inspect and televise at least 600 linear feet of pipe. The inspecting, televising and video recording equipment shall be mounted in a self-propelled van or truck that is capable of moving from location to location. The van or truck shall have markings painted on it indicating the name of the Contractor.
- The camera head shall have pan and tilt capabilities in order to examine pipe defects. The camera shall have an adequate lighting system that clearly illuminates the entire circumference of the pipe segment under inspection. The equipment shall have hardware and software that is compatible with the camera and capable of electronically recording and saving pipe inspection information with software that follows NASSCO PACP inspection protocol.

A digital video and corresponding log (hard copy and electronic format compatible with other NASSCO PACP certified software) of the conditions present in the pipe sections before installation of the liner shall be made and kept for later reference and delivery to the City.

Each digital video segment shall be named according to the “upstream structure number–downstream structure number.mpg” format. The digital video shall document in a clear and continuous manner the condition of the sewer segment from the upstream structure to the downstream structure. No interruptions or missing segments shall be allowed unless noted in writing by the City's Project Engineer. The City will reject any digital video that has foggy or static conditions on it. The video shall display on a continuous basis the sanitary sewer pipe footage, continuous video footage along total length, street or address of the sewer segment, the upstream and downstream manhole number for the sewer segment being televised, the sewer pipe diameter and the date of the televising.

509.6(c) Installation.

The CIPP installation shall be in accordance with ASTM F 1216 for Heat Cure CIPP systems. Ultraviolet Light Cured systems shall be installed in according to the manufacturer's specifications and applicable ASTM F 2019 standards.

1. Resin Impregnation.

A certified Wet Out Report shall be completed, signed, and submitted for each liner delivered to the site. The Wet Out Report shall include, but is not limited to, wet-out date, resin identification, resin weight, resin admixtures, fabric tube length, diameter, and thickness.

For Heat Cure CIPP systems, the tube shall be vacuum-impregnated with resin (wet-out) under controlled conditions. The volume of resin used shall be sufficient to fill all voids in the tube material at nominal thickness and diameter. The volume shall be adjusted by adding 5% to 10% excess resin volume compared to the volume of the felt to compensate for the change in resin volume due to polymerization and to allow for any migration of resin into the cracks and joints in the original pipe.

For Ultraviolet Light Cure CIPP systems, the (wet-out) fiberglass tube shall meet ASTM F 2019 as applicable, and shall have a uniform thickness and excess resin distribution that when compressed at installation pressures will meet or exceed the design thickness after cure.

2. Tube Insertion.

The wet out tube shall be positioned in the pipeline using either inversion (ASTM F 1216) or a pull-in method (ASTM F 1743), Ultraviolet Light Cure CIPP systems must use a pull-in method (ASTM F 1743). If pulled into place, a power winch shall be utilized and care shall be exercised not to damage the tube as a result of pull-in friction. The tube shall be pulled-in or inverted through an existing manhole or approved access point and fully extend to the next designated manhole or termination point.

A. Inversion (ASTM F 1216)

1. Using Hydrostatic Head - The wet-out tube shall be inserted through an existing manhole or other approved access by means of an inversion process and the application of a hydrostatic head sufficient to fully extend it to the next designated manhole or termination point. The tube shall be inserted into the vertical inversion standpipe with the impermeable plastic membrane side out. At the lower end of the inversion standpipe, the tube shall be turned inside out and attached to the standpipe so that a leakproof seal is created. The inversion head shall be adjusted to be of sufficient height to cause the impregnated tube to invert from point of inversion to point of termination and hold the tube tight to the pipe wall, producing dimples at side connections. Care shall be taken during the inversion so as not to over-stress the felt fiber.
2. Using Air Pressure - The wet-out tube shall be inserted through an existing manhole or other approved access by means of an inversion process and the application of air pressure sufficient to fully extend it to the next designated manhole or termination point. The tube shall be connected by an attachment at the upper end of the guide chute so that a leakproof seal is created and with the impermeable plastic membranes

side out. As the tube enters the guide chute, the tube shall be turned inside out. The inversion air pressure shall be adjusted to be of sufficient pressure to cause the impregnated tube to invert from point of inversion to point of termination and hold the tube tight to the pipe wall, producing dimples at side connections. Care shall be taken during the inversion so as not to overstress the woven and nonwoven materials.

3. Required Pressures - Before the inversion begins, the tube manufacturer shall provide the minimum pressure required to hold the tube tight against the existing conduit, and the maximum allowable pressure so as not to damage the tube. Once the inversion has started, the pressure shall be maintained between the minimum and maximum pressures until the inversion has been completed.

**B. Pull-in Method (ASTM F 1743)**

1. Perforation of Resin-Impregnated Tube—Prior to pulling the resin-impregnated fabric tube in place, the outer impermeable plastic coating may optionally be perforated. When the resin-impregnated fabric tube is perforated, this shall allow resin to be forced through the perforations and out against the existing conduit by the force of the hydrostatic head or air pressure against the inner wall of the calibration hose.

The perforation shall be done after fabric tube impregnation with a perforating roller device at the point of manufacture or at the jobsite. Perforations shall be made on both sides of the lay-flat fabric tube covering the full circumference with a spacing no less than 1.5 in. (38.1 mm) apart. Perforating slits shall be a minimum of 0.25 in. (6.4 mm) long.

2. Pulling Resin-Impregnated Tube into Position—The wet-out fabric tube shall be pulled into place using a power winch. The saturated fabric tube shall be pulled through an existing manhole or other approved access to fully extend to the next designated manhole or termination point. Care shall be exercised not to damage the tube as a result of friction during pull-in, especially where curvilinear alignments, multilinear alignments, multiple offsets, protruding services, and other friction-producing host pipe conditions are present. Once the fabric tube is in place, it shall be attached to a vertical standpipe so that the calibration hose can invert into the center of the resin-impregnated fabric tube. The vertical standpipe shall be of sufficient height of water head to hold the fabric tube tight to the existing pipe wall, producing dimples at side connections. A device such as a dynamometer or load cell shall be provided on the winch or cable to monitor the pulling force. Measure the overall elongation of the fabric tube after pull-in completion. The acceptable longitudinal elongation shall not be more than 5 % of the overall length measured after the calibration hose has been installed, or exceed the recommended pulling force.

**C. Lubricant During Installation**

The use of a lubricant during installation is recommended to reduce friction during inversion. This lubricant shall be poured into the fluid in the standpipe in order to coat the calibration hose during inversion. When air is used to invert the calibration hose, the lubricant shall be applied directly to the calibration hose. The lubricant used shall be a nontoxic, oil-based product that has no detrimental

effects on the tube or boiler and pump system, and will not adversely affect the fluid to be transported.

3. Curing.

For Heat Cure CIPP systems, curing shall be accomplished by utilizing circulating heated water or steam under hydrostatic pressure in accordance with ASTM F 1216 and the manufacturer's recommended cure schedule. For Ultraviolet Light Cure CIPP systems, curing shall be accomplished by utilizing air pressure and ultraviolet light in accordance with ASTM F 2019 and the manufacturer's recommended cure schedule.

A. Curing Method

1. Circulating Heated Water

After inversion is completed, a suitable heat source and water recirculation equipment are required to circulate heated water throughout the pipe. The equipment shall be capable of delivering hot water throughout the section to uniformly raise the water temperature above the temperature required to effect a cure of the resin. Water temperature in the line during the cure period shall be as recommended by the resin manufacturer.

The heat source shall be fitted with suitable monitors to gage the temperature of the incoming and outgoing water supply. Another such gage shall be placed between the impregnated tube and the pipe invert at the termination to determine the temperatures during cure.

2. Using Steam

After inversion is completed, suitable steam-generating equipment is required to distribute steam throughout the pipe. The equipment shall be capable of delivering steam throughout the section to uniformly raise the temperature within the pipe above the temperature required to effect a cure of the resin. The temperature in the line during the cure period shall be as recommended by the resin manufacturer.

The steam-generating equipment shall be fitted with a suitable monitor to gage the temperature of the outgoing steam. The temperature of the resin being cured shall be monitored by placing gages between the impregnated tube and the existing pipe at both ends to determine the temperature during cure.

Steam curing systems shall include an elevated steam discharge. The City of Madison Construction Inspector shall monitor and record styrene levels at this point for each liner curing. At direction of the Construction Inspector any steam condensate or styrene residue shall be cleaned and disposed at the Contractor's expense.

3. Using Ultraviolet Light

After inversion is completed, the fiberglass liner shall be cured with ultraviolet light sources at a constant inner pressure. The ultraviolet light sources shall be assembled according to the Manufacturer's specifications for the liner. The defined parameters

for curing speed, inner air pressure, exothermic temperatures, and wattage are to be controlled, measured, and documented during the entire curing process to be submitted to the Engineer with the post CCTV inspection. The inner film material should be removed and discarded after curing to provide optimal quality of the final product.

B. Initial Cure

Initial cure will occur during temperature heat-up and is completed when exposed portions of the new pipe appear to be hard and sound and the remote temperature sensor indicates that the temperature is of a magnitude to realize an exotherm or cure in the resin. After initial cure is reached, the temperature shall be raised to post-cure temperatures recommended by the resin manufacturer. The post-cure temperature shall be held for a period as recommended by the resin manufacturer, during which time the recirculation of the water and cycling of the boiler or distribution and control of steam to maintain the temperature continues. The curing of the CIPP must take into account the existing pipe material, the resin system, and ground conditions (temperature, moisture level, and thermal conductivity of soil).

C. Required Pressure

The estimated maximum and minimum pressure required to hold the flexible tube tight against the existing conduit during the curing process shall be provided by the manufacturer and shall be increased to include consideration of the external ground water, if present. Once the cure has started and dimpling for laterals is completed, the required pressures shall be maintained until the cure has been completed. The pressure shall be maintained within the estimated maximum and minimum pressure during the curing process. If the steam pressure or hydrostatic head drops below the recommended minimum during the cure, the CIPP shall be inspected for lifts or delaminations and evaluated for its ability to fully meet the applicable requirements of these specifications and ASTM F 1216 or ASTM F 2019.

D. Cool-Down

1. Using Cool Water After Heated Water Cure—The new pipe shall be cooled to a temperature below 100°F (38°C) before relieving the static head in the inversion standpipe. Cool-down may be accomplished by the introduction of cool water into the inversion standpipe to replace water being drained from a small hole made in the downstream end. Care shall be taken in the release of the static head so that a vacuum will not be developed that could damage the newly installed pipe.
2. Using Cool Water After Steam Cure— The new pipe shall be cooled to a temperature below 113°F (45°C) before relieving the internal pressure within the section. Cool-down may be accomplished by the introduction of cool water into the section to replace the mixture of air and steam being drained from a small hole made in the downstream end. Care shall be taken in the release of the air pressure so that a vacuum will not be developed that could damage the newly installed pipe.

4. Sealing Liner at Sewer Access Structures.

The Contractor shall provide a watertight seal between the host pipe and liner pipe at the connection to the sewer access structure. Seals shall be made with an epoxy or resin mixture compatible with the liner/resin system. Hydraulic cements and quick-set cement products are not acceptable.

The Contractor shall reconstruct benches and channels in manholes with grout to match new invert elevations.

5. Reinstatement of Service Connections.

The Contractor shall be responsible for confirming the locations of all service connections prior to installing and curing the CIPP. All service connection shall be reconnected unless otherwise directed by the Engineer. Service connections shall not be out of service for more than 8 hours during the lining process.

The Contractor shall reinstate all service connections to buildings without excavation, utilizing a remote controlled cutting device, monitored by a video TV camera. The Contractor shall certify he/she has a minimum of 2 complete working cutters plus spare key components on the site before each inversion. The operator of the remote controlled cutting device shall have at least 2 years experience with such equipment.

Service connections shall be reestablished to a minimum of 95% of the flow capacity. Any service connection opened to greater than 100% of its original diameter shall have a "Top Hat" system installed at the Contractor's Expense. The "Top Hat" type liner shall be Amerik Supplies, Inc. Top Hat, or equal. The Top Hat must extend at least 18-inches into lateral and create at least a 3-inch brim molded flat against lined mainline pipe with a Manufacturer approved adhesive to ensure a tight bond against the CIPP.

Liner shall be sufficiently tight so that there is no annular space between the connection and the liner.

No additional payment will be made for excavations for the purpose of reopening connections and the Contractor will be responsible for all costs and liability associated with such excavation and restoration work.

6. Chemical Grouting of Service Connections.

The intent of lateral connection sealing is to test and seal sewer lateral connections using a specialized chemical grout packer. The purpose of this procedure is the elimination of infiltration into sewers that are otherwise structurally sound.

The Contractor shall proof test each reinstated service connection via an air test or other approved method. Service connections shall be air tested by isolating the area to be tested with the packer and applying positive pressure into the isolated "void" area. A sensing unit shall be used for continuous monitoring of the "void" pressure. This sensing unit shall be located within the "void" area and accurately transmit pressure readout to the control panel. The test procedure shall consist of applying air pressure into each isolated VOID area. To isolate a VOID, the lateral sealing packer shall be positioned straddling the service connection. The operator shall inflate the packer ends to isolate the service connection and insert an inflatable inversion tube. The service connection shall be tested with a gauge pressure of one-half (1/2) psi per foot of depth of sewer or a minimum of four (4) psi,



whichever is larger. The VOID pressure shall be observed during this test for a minimum of 10 seconds. If the VOID pressure drop is greater than 1 psi in 10 seconds, the service connection is considered to have failed the air test. If no pressure can be built up, the connection will also have failed the test. Any connection failing the test shall be sealed and retested utilizing the same method and procedures until it does pass the test. The cost of retesting lateral connections shall be considered incidental and included in the cost of sealing sanitary sewer lateral connection.

Active leaks at reinstated service connections and reinstated connections that do not pass a proof test shall be sealed by chemical grout or other method approved by the Engineer. Seals shall extend from sanitary sewer main into the service connection for a minimum of 18 inches. Grout shall be 3M Scotch Seal #5619 Polyurethane, DeNeef Multigel Polyurethane and Avanti International AV118 Duriflex or equal.

### **509.7 Inspection and Testing.**

#### **509.7(a) CIPP Samples.**

The Contractor shall furnish all samples for product testing to the Project Engineer. The Project Engineer shall take possession of the samples for testing and shall maintain the chain of custody, deliver the samples to an approved laboratory and pay for all material and product testing performed under this contract.

The samples shall be prepared and physical properties tested in accordance with ASTM F 1216. The flexural properties must meet or exceed the values listed in Table 1, Section 509.5(d).

For each inversion length, the preparation of two CIPP samples is required, one from each of the following two methods:

1. The sample shall be cut from a section of cured CIPP at an intermediate manhole or at the termination point that has been inverted through a like diameter pipe which has been held in place by a suitable heat sink, such as sandbags.
2. The sample shall be fabricated from material taken from the tube and the resin/catalyst system used and cured in a clamped mold placed in the downtube when circulating heated water is used and in the silencer when steam is used.

Each sample shall be large enough to provide five specimens for flexural testing and tensile testing.

The following test procedures shall be followed after the sample is cured and removed.

**Short-Term Flexural (Bending) Properties** - The initial tangent flexural modulus of elasticity and flexural stress shall be measured for gravity and pressure pipe applications in accordance with Test Methods D 790 and shall meet the requirements of Table 1, Section 509.5(d).

**Tensile Properties** - The tensile strength shall be measured for pressure pipe applications in accordance with Test Method D 638 and must meet the requirements of Table 1, Section 509.5(d).

**Gravity Pipe Leakage Testing** - Gravity pipes shall be tested using an exfiltration test method where the CIPP is plugged at both ends and filled with water. This test shall take place after the CIPP has cooled down to ambient temperature. This test is limited to pipe lengths with no service laterals and

diameters of 36 in. or less. The allowable water exfiltration for any length of pipe between termination points shall not exceed 50 U.S. gallons per inch of internal pipe diameter per mile per day, providing that all air has been bled from the line. During exfiltration testing, the maximum internal pipe pressure at the lowest end shall not exceed 10 ft (3.0 m) of water or 4.3 psi (29.7 kPa) and the water level inside of the inversion standpipe shall be 2 ft (0.6 m) higher than the top of the pipe or 2 ft higher than the groundwater level, whichever is greater. The leakage quantity shall be gaged by the water level in a temporary standpipe placed in the upstream plug. The test shall be conducted for a minimum of one hour.

**Delamination Test** - If required by the owner in the contract documents or purchase order, a delamination test shall be performed on each inversion length specified. The CIPP samples shall be prepared in accordance with 509.7(a)2, except that a portion of the tube material in the sample shall be dry and isolated from the resin in order to separate tube layers for testing. Delamination testing shall be in accordance with Test Method D 903, with the following exceptions:

1. The rate of travel of the power-actuated grip shall be 1 in. (25 mm)/min.
2. Five test specimens shall be tested for each inversion specified.
3. The thickness of the test specimen shall be minimized, but shall be sufficient to adequately test delamination of nonhomogeneous CIPP layers.
4. The peel or stripping strength between any nonhomogeneous layers of the CIPP laminate shall be a minimum of 10 lb/in. (178.60 g/mm) of width for typical CIPP applications.

**CIPP Wall Thickness** - The method of obtaining CIPP wall thickness measurements shall be determined in a manner consistent with 8.1.2 of Specification D 5813. Thickness measurements shall be made in accordance with Practice D 3567 for samples prepared in accordance with 509.7(a)2. Make a minimum of eight measurements at evenly spaced intervals around the circumference of the pipe to ensure that minimum and maximum thicknesses have been determined. Deduct from the measured values the thickness of any plastic coatings or CIPP layers not included in the structural design of the CIPP.

The average thickness shall be calculated using all measured values and shall meet or exceed minimum design thickness as agreed upon between purchaser and seller. If the average thickness does not meet or exceed the minimum design thickness but is still determined to be acceptable, the bid item payment may be reduced by the percentage difference in thickness for the subject lining segment. The minimum wall thickness at any point shall not be less than 87.5% of the specified design thickness as agreed upon between purchase and seller.

An alternative method for measuring the wall thickness may be performed within the installed CIPP at either end of the pipe by the ultrasonic pulse echo method as described in Practice E 797. A minimum of eight (8) evenly spaced measurements shall be made around the internal circumference of the installed CIPP within the host pipe at a distance of 12 to 18 in. from the end of the pipe. For pipe diameters of fifteen (15) in. or greater, a minimum of sixteen (16) evenly spaced measurements shall be recorded. The ultrasonic method to be used is the flaw detector with A-scan display and direct thickness readout as defined in 6.1.2 of E 797. A calibration block shall be manufactured from the identical materials used in the installed CIPP to calibrate sound velocity through the liner.

Calibration of the transducer shall be performed daily in accordance with the equipment manufacturer's recommendations. The average thickness shall be calculated using all measured values and shall meet or exceed minimum design thickness as agreed upon between purchaser and seller. The minimum wall thickness at any point shall not be less than 87.5% of the specified design thickness.

**CCTV Inspection and Acceptance** - The Contractor shall perform a detailed closed-circuit television inspection in accordance with NAASCO's Pipeline Assessment and Certification Program (PACP) standards, after installation of the CIPP liner and reconnection and grouting of the service connections. The camera shall be panned 360 degrees around the circumference of the pipe and along the wall of the finished pipe at 10 foot intervals. The finished liner shall be continuous over the entire length of the installation and shall be free of significant visual defects, damage, deflection, holes, leaks and other defects. Unedited digital documentation of the inspection shall be provided to the Owner within ten (10) working days of the liner installation. The data shall note the inspection date, location of all reconnected service connections, debris, as well as any other defects in the liner, including, but not limited to, gouges, cracks, bumps, or bulges. If post installation inspection documentation is not submitted within ten (10) working days of the liner installation, the City may at its discretion suspend any further installation of CIPP until the post installation documentation is submitted. As a result of this suspension, no additional working days will be added to the contract, nor will any adjustment be made for increase in cost. Immediately prior to conducting the closed circuit television inspection, the Contractor shall thoroughly clean the newly installed liner removing all debris and buildup that may have accumulated.

The installation shall be inspected by closed-circuit television. No infiltration of groundwater shall be observed. All live service entrances shall be accounted for and be unobstructed. CCTV inspection of the CIPP liner shall be in accordance with ASTM F 1216 and Section 509.6(b).

The contractor shall take a still image of the watertight seal between the host pipe and liner at the connection to the sewer access structure.

If the Engineer's review of the final CCTV submittal identifies repairable defects, the Contractor may be requested to submit a manufacturer reviewed/approved repair plan rather than reinstalling the entire defective CIPP. Any such repairs shall include an extended warranty by the Contractor for one (1) additional year from the expiration of the Contract warranty.

The following repair methods for common defects are considered acceptable:

- Defect: Wrinkles/ridges exceeding 5% of pipe diameter outside of 120-degree invert arc – OR – wrinkles/ridges exceeding 2% of pipe diameter inside of the 120-degree invert arc.
  - Repair: Grind to within required tolerance, coat ground area with manufacturer's approved resin. Point repair may be required if minimum thickness is affected by repair.
  - Rejection Criteria: The Engineer may reject the work if wrinkles or ridges exceed 10% of pipe diameter.
- Defect: Holes, tears, soft spots, lifts, delamination, blisters/bubbles.
  - Repair: Point repairs under manufacturer's approved recommendations.
  - Rejection Criteria: If defective areas cover greater than 5% of the surface area the Engineer reserves the right to reject the work.

- Defect: CIPP thickness less than calculated minimum thickness.
  - Repair: If the Engineer determines that the CIPP is acceptable, payment may be reduced by the percentage below the design minimum thickness. In some cases, a second CIPP within the first may be allowed.
  - Rejection Criteria: If the actual thickness is less than 87.5% of the design minimum thickness, the Engineer reserves the right to reject the work.
- Defect: Service reinstated to greater than 100% of original flow capacity.
  - Repair: A “Top Hat” system must be installed at the Contractor’s Expense. The “Top Hat” type liner shall be Amerik Supplies, Inc. Top Hat, or equal. The Top Hat must extend at least 18-inches into lateral and create at least a 3-inch brim molded flat against lined mainline pipe with a Manufacturer approved adhesive to ensure a tight bond against the CIPP.
  - Rejection Criteria: The Engineer reserves the right to reject any improperly installed Top Hat repairs.

Additional defects may be identified, and will be handled on a case-by-case basis.

### **509.8 Measurement and Payment.**

509.8.1 Bid Item 50901 - Furnish and Install CIPP to Rehabilitate 6-Inch Diameter Sanitary Sewer Mains.

#### Description.

Work under this item shall include furnishing and installing a cured-in-place pipe within various existing 6-inch diameter clay sewers located throughout the City of Madison. All equipment, tools, labor, materials, and procedures shall conform to the requirements set forth in these specifications.

#### Method of Measurement.

This item shall be measured in units of linear feet for each section of sanitary sewer main successfully lined. The sanitary sewer main shall be measured on a straight horizontal line along the centerline of sewer. The distance through sanitary access structures shall not be included in the measurement.

#### Basis of Payment.

The contract unit price shall include furnishing all equipment, tools, labor and materials referenced in these specifications; mobilizing and preparing site; televising existing sanitary sewer main before and after liner installation; cleaning existing sewer main prior to lining; placing cured-in-place-pipe; bypassing sanitary sewage around the section undergoing lining; controlling traffic to facilitate lining operations and/or sewage bypassing; testing liner material; cleaning the site and all other general requirements and incidental work pertaining to these specifications. NOTE: The reinstatement and reconnection of all wye openings in the existing sewer main is a separate bid and payment item.

509.8.2 Bid Item 50902 - Furnish and Install CIPP to Rehabilitate 8-Inch Diameter Sanitary Sewer Mains.

Description.

Work under this item shall include furnishing and installing a cured-in-place pipe within various existing 8-inch diameter clay sewers located throughout the City of Madison. All equipment, tools, labor, materials and procedures shall conform to the requirements set forth in these specifications.

Method of Measurement.

This item shall be measured in units of linear feet for each section of sanitary sewer main successfully lined. The sanitary sewer main shall be measured on a straight horizontal line along the centerline of sewer. The distance through sanitary access structures shall not be included in the measurement.

Basis of Payment.

The contract unit price shall include furnishing all equipment, tools, labor and materials referenced in these specifications; mobilizing and preparing site; televising existing sanitary sewer main before and after liner installation; cleaning existing sewer main prior to lining; placing cured-in-place-pipe; bypassing sanitary sewage around the section undergoing lining; controlling traffic to facilitate lining operations and/or sewage bypassing; testing liner material; cleaning the site and all other general requirements and incidental work pertaining to these specifications. NOTE: The reinstatement and reconnection of all wye openings in the existing sewer main is a separate bid and payment item.

509.8.3 Bid Item 50903 - Furnish and Install CIPP to Rehabilitate 10-Inch Diameter Sanitary Sewer Mains.

Description.

Work under this item shall include furnishing and installing a cured-in-place pipe within various existing 10-inch diameter clay sewers located throughout the City of Madison. All equipment, tools, labor, materials, and procedures shall conform to the requirements set forth in these specifications.

Method of Measurement.

This item shall be measured in units of linear feet for each section of sanitary sewer main successfully lined. The sanitary sewer main shall be measured on a straight horizontal line along the centerline of sewer. The distance through sanitary access structures shall not be included in the measurement.

Basis of Payment.

The contract unit price shall include furnishing all equipment, tools, labor and materials referenced in these specifications; mobilizing; preparing site; televising the existing sanitary sewer main before and after liner installation; cleaning the existing sewer main prior to lining; placing the CIPP; bypassing sanitary sewage around the section undergoing lining; controlling traffic to facilitate lining operations and/or sewage bypassing; testing of liner material; cleaning operations and all other general requirements and incidental work pertaining to these specifications. NOTE: The

reinstatement and reconnection of all wye openings in the existing sewer main is a separate bid and payment item.

509.8.4 Bid Item 50904 - Furnish and Install CIPP to Rehabilitate 12-Inch Diameter Sanitary Sewer Mains.

Description.

Work under this item shall include furnishing and installing cured-in-place-pipe within various existing 12" clay sewers located throughout the City of Madison. All equipment, tools, labor, materials and procedures shall conform to the requirements set forth in these specifications.

Method of Measurement.

This item shall be measured in units of linear feet for each section of sanitary sewer main successfully lined. The sanitary sewer main shall be measured on a straight horizontal line along the centerline of the sewer. The distance through sanitary access structures shall not be included in the measurement.

Basis of Payment.

The contract unit price shall include furnishing all equipment, tools, labor, and materials referenced in these specifications; mobilizing; preparing the site; televising the existing sanitary sewer main before and after liner installation; cleaning the existing sewer main prior to lining; placing the CIPP; bypassing sanitary sewage around the section undergoing lining; controlling traffic to facilitate lining operations and/or sewage bypassing; testing liner material; cleaning operations and all other general requirements and incidental work pertaining to these specifications. NOTE: The reinstatement and reconnection of all wye openings in the existing sewer main is a separate bid and payment item.

509.8.5 Bid Item 50905 - Furnish and Install CIPP to Rehabilitate 15-Inch Diameter Sanitary Sewer Mains.

Description.

Work under this item shall include furnishing and installing cured-in-place-pipe within various existing 15" clay sewers located throughout the City of Madison. All equipment, tools, labor, materials and procedures shall conform to the requirements set forth in these specifications.

Method of Measurement.

This item shall be measured in units of linear feet for each section of sanitary sewer main successfully lined. The sanitary sewer main shall be measured on a straight horizontal line along the centerline of the sewer. The distance through sanitary access structures shall not be included in the measurement.

Basis of Payment.

The contract unit price shall include furnishing all equipment, tools, labor, and materials referenced in these specifications; mobilizing; preparing the site; televising the existing sanitary sewer main before and after liner installation; cleaning the existing sewer main prior to lining; placing the CIPP; bypassing sanitary sewage around the section undergoing lining; controlling traffic to facilitate lining

## Part V - Sewers and Sewer Structures

operations and/or sewage bypassing; testing liner material; cleaning operations and all other general requirements and incidental work pertaining to these specifications. NOTE: The reinstatement and reconnection of all wye openings in the existing sewer main is a separate bid and payment item.

### 509.8.6 Bid Item 50906 - Furnish and Install CIPP to Rehabilitate 18-Inch Diameter Sanitary Sewer Mains.

#### Description.

Work under this item shall include furnishing and installing cured-in-place-pipe within various existing 18" clay sewers located throughout the City of Madison. All equipment, tools, labor, materials and procedures shall conform to the requirements set forth in these specifications.

#### Method of Measurement.

This item shall be measured in units of linear feet for each section of sanitary sewer main successfully lined. The sanitary sewer main shall be measured on a straight horizontal line along the centerline of the sewer. The distance through sanitary access structures shall not be included in the measurement.

#### Basis of Payment.

The contract unit price shall include furnishing all equipment, tools, labor, and materials referenced in these specifications; mobilizing; preparing the site; televising the existing sanitary sewer main before and after liner installation; cleaning the existing sewer main prior to lining; placing the CIPP; bypassing sanitary sewage around the section undergoing lining; controlling traffic to facilitate lining operations and/or sewage bypassing; testing liner material; cleaning operations and all other general requirements and incidental work pertaining to these specifications. NOTE: The reinstatement and reconnection of all wye openings in the existing sewer main is a separate bid and payment item.

### 509.8.7 Bid Item 50907 - Furnish and Install CIPP to Rehabilitate 21-Inch Diameter Sanitary Sewer Mains.

#### Description.

Work under this item shall include furnishing and installing cured-in-place-pipe within various existing 21" clay sewers located throughout the City of Madison. All equipment, tools, labor, materials and procedures shall conform to the requirements set forth in these specifications.

#### Method of Measurement.

This item shall be measured in units of linear feet for each section of sanitary sewer main successfully lined. The sanitary sewer main shall be measured on a straight horizontal line along the centerline of the sewer. The distance through sanitary access structures shall not be included in the measurement.

#### Basis of Payment.

The contract unit price shall include furnishing all equipment, tools, labor, and materials referenced in these specifications; mobilizing; preparing the site; televising the existing sanitary sewer main before and after liner installation; cleaning the existing sewer main prior to lining; placing the CIPP;

## Part V - Sewers and Sewer Structures

bypassing sanitary sewage around the section undergoing lining; controlling traffic to facilitate lining operations and/or sewage bypassing; testing liner material; cleaning operations and all other general requirements and incidental work pertaining to these specifications. NOTE: The reinstatement and reconnection of all wye openings in the existing sewer main is a separate bid and payment item.

### 509.8.8 Bid Item 50908 - Furnish and Install CIPP to Rehabilitate 24-Inch Diameter Sanitary Sewer Mains.

#### Description.

Work under this item shall include furnishing and installing cured-in-place-pipe within various existing 24" clay sewers located throughout the City of Madison. All equipment, tools, labor, materials and procedures shall conform to the requirements set forth in these specifications.

#### Method of Measurement.

This item shall be measured in units of linear feet for each section of sanitary sewer main successfully lined. The sanitary sewer main shall be measured on a straight horizontal line along the centerline of the sewer. The distance through sanitary access structures shall not be included in the measurement.

#### Basis of Payment.

The contract unit price shall include furnishing all equipment, tools, labor, and materials referenced in these specifications; mobilizing; preparing the site; televising the existing sanitary sewer main before and after liner installation; cleaning the existing sewer main prior to lining; placing the CIPP; bypassing sanitary sewage around the section undergoing lining; controlling traffic to facilitate lining operations and/or sewage bypassing; testing liner material; cleaning operations and all other general requirements and incidental work pertaining to these specifications. NOTE: The reinstatement and reconnection of all wye openings in the existing sewer main is a separate bid and payment item.

### 509.8.9 Bid Item 50909 - Reinstate and Reconnect Service Openings.

#### Description.

Work under this item shall include reinstatement and reconnection of all service openings in the existing sewer main lined under this contract. Service connections to buildings shall be reopened by the Contractor without excavation, utilizing a remote controlled cutting device, monitored by a closed circuit television camera. Unless otherwise directed by the City, all openings in the main shall be reinstated.

No additional payment shall be made for excavations for the purpose of reopening connections and the Contractor shall be responsible for all costs and liability associated with such excavation and restoration work.

#### Method of Measurement.

This item shall be measured in units of each for each successfully reinstated and reconnected wye for liner installed in the existing sewer main.



Basis of Payment.

The contract unit price shall include furnishing all equipment, tools, labor, and materials referenced in Section 500 of this specification and all other general requirements and incidental work pertaining to Section 500 of this specification. Please note that this includes proof testing of each service connection.

509.8.10 Bid Item 50910 - Chemical Grout Sealing of Sanitary Sewer Service Connections.

Description.

Work under this item shall include the testing and sealing of for all reinstated sanitary sewer service connections.

Method of Measurement.

This item shall be measured in units of each for each successfully tested and grouted and sealed service connection to the existing sewer main.

Basis of Payment.

The contract unit price shall include furnishing all equipment, tools, labor, and materials and all other general requirements and incidental work pertaining to the testing and sealing of each connection.

## Part VI - Traffic Engineering Electrical & Pavement Markings

ARTICLE 601 - GENERAL REQUIREMENTS.....	1
601.1 Description.....	1
601.2 Equipment.....	1
601.3 Finishing Work and Maintenance.....	1
601.4 Repairs and Replacement.....	2
601.5 Codes, Permits and Inspections.....	2
601.6 Testing.....	2
601.7 Disposal of Excess Excavation.....	3
601.8 Tree Trimming.....	3
601.9 Electrical Equipment.....	3
601.10 Materials Furnished by the City.....	3
ARTICLE 602 - UNDERGROUND DISTRIBUTION SYSTEMS.....	4
602.1 General.....	4
602.2 Materials.....	4
602.3 Construction Methods.....	6
602.4 Measurement and Payment.....	10
602.5 Electrical Trench.....	11
ARTICLE 603 - REMOVAL OF AERIAL DISTRIBUTION SYSTEMS.....	13
603.1 General.....	13
603.2 Construction Methods.....	13
603.3 Measurement and Payment.....	13
ARTICLE 604 - BASES FOR STREET LIGHTING UNITS AND TRAFFIC SIGNAL STANDARDS AND CONTROLLERS.....	14
604.1 General.....	14
604.2 Materials.....	14
604.3 Construction Methods.....	14
604.4 Measurement and Payment.....	15
604.5 Removal of Existing Street Light Pole, Traffic Signal Poles and Cabinets, and Miscellaneous Electrical Bases and Abandoning Handholes and Electrical Utility Access Structures.....	15
604.6 Auger Street Light Base.....	16
604.7 Base for Multi Space Parking Meters.....	17
ARTICLE 605 - INSTALLATION OF STREET LIGHTING UNITS.....	19
605.1 General.....	19
605.2 Construction Methods.....	19
605.3 Measurement and Payment.....	20
ARTICLE 606 - INSTALLATION OF METERED OR UNMETERED ELECTRIC SERVICE.....	22
606.1 General.....	22
606.2 Construction Methods.....	22
606.3 Measurement and Payment.....	22

ARTICLE 607 - ELECTRICAL UTILITY ACCESS STRUCTURES, ELECTRICAL HANDHOLES AND BOX-OUTS .....	23
607.1    General.....	23
607.2    Construction Methods.....	23
607.3    Measurement and Payment.....	23
ARTICLE 608 - PAVEMENT MARKINGS .....	24
608.1    Description.....	24
608.2    General Requirements.....	24
608.3    Method of Measurement.....	24
ARTICLE 609 - TEMPORARY PAVEMENT MARKINGS.....	25
609.1    Description.....	25
609.2    General Requirements.....	25

## **ARTICLE 601 - GENERAL REQUIREMENTS**

---

### **601.1 Description.**

Traffic signal and street lighting construction shall consist of excavating the required trenches and tunnels; furnishing and laying therein the required conduit; placing cable-in-duct and/or signal cable; installing the required structures and appurtenances; backfilling the trenches; restoring the site of the work; and completing the work to the required lines and grades. All work shall be performed as shown on the plans and in accordance with the contract.

The existing signal and lighting poles, conduits, handholes, and manholes not scheduled for removal or abandonment shall be protected during construction. If the contractor believes that damage to such facilities is unavoidable, the contractor shall not damage or remove any facilities until the City Traffic Engineering electrical inspector has reviewed and approved such actions. Any damage or removal of City electrical conduit, wire, fiber, or structures, without the specific approval by the City Traffic Engineering electrical inspector shall be promptly repaired or replaced by and at the expense of the contractor. The City may elect to do repair work with City crews. The cost for any repair work done by the City will be billed to the contractor.

Any damage or removal of City street lighting, traffic signal, or communication facilities shall be repaired or replaced within 24 hours, but any resulting street light outage resulting from such damage or removal shall be confined to as few numbers of street lights as possible. The streetlight circuits shall remain operational each and every night. The City reserves the right to make temporary or permanent repairs at any time after the damage or removal, even within 24 hours of the damage or removal, with the full cost of such work, including engineering time, billed to the general contractor.

Unless a manhole (utility access structure), handhole, or structure is specifically designated for removal, it shall be saved. The contractor shall consult with the Traffic Engineering Electrical Inspector before removing or damaging any existing facilities.

### **601.2 Equipment.**

Equipment and tools necessary for performing all parts of the work shall be satisfactory in design, capacity, and mechanical condition for the purposes intended, and any equipment which is not maintained in full working order, or which as used by the Contractor is inadequate to obtain the results prescribed, shall be repaired, improved or supplemented to obtain the progress and quality of work contemplated by the contract.

### **601.3 Finishing Work and Maintenance.**

The Contractor shall maintain all trenches and other excavations, keeping them well filled and in a safe condition for travel, and shall deliver to the City, at the time of acceptance, a finished job with all trenches in a condition satisfactory to the Engineer.

All concrete, asphalt, and gravel pavements; stone flagging or paving; sidewalks; curbs and gutters; culverts; fences; or other structures which may have been damaged or displaced by the Contractor shall be relaid properly to the original line and grade. In areas with established and tended sod, the Contractor shall resod areas disturbed by the construction; all other areas disturbed by the construction shall be seeded. All of the above work shall be in accordance with these Specifications, or in absence of applicable specifications, to restore the original condition of the structure or area.

The Contractor shall restore and maintain all asphalt and gravel surfaces in first class condition until final acceptance of the project by the Common Council. All structures and conduit shall be cleaned of any accumulations of silt, debris or other foreign matter. Conduit shall be cleaned by use of the proper size mandrel. The area along the entire installation shall be left clean and graded in a condition satisfactory to the Engineer.

Unless otherwise provided, all costs of the work included in this Section shall be at the expense of the Contractor, and shall be included in the unit price bid for the contract items with which such work is associated. Final payment will be withheld until such work is done in a manner satisfactory to the Engineer.

#### **601.4 Repairs and Replacement.**

When compliance with these Specifications requires repairs, such repairs shall be made by replacement of the defective section with new materials of equal quality installed in accordance with the construction specifications governing the original installation. These repairs shall include total and complete restoration of any disturbed surface to its original, or better than original, condition. Unless otherwise provided, all costs of the work included in this Section shall be at the expense of the Contractor.

#### **601.5 Codes, Permits and Inspections.**

The electrical work shall be done in strict accordance with the Wisconsin State Electrical Code and the Electrical Code of the City of Madison and shall be subject to inspection by the City Building Inspection and Rehabilitation Unit.

The Contractor shall obtain and pay for all necessary permits and certificates of inspection.

The City Traffic Engineering Inspector shall be notified at least twenty-four (24) hours in advance of beginning any underground electrical construction work, such as installing cable-in-duct, PVC conduit and concrete bases, and shall be updated frequently as to stopping and restarting underground work. All underground conduit, cable, or concrete base forms shall be inspected by the City Traffic Engineering Inspector before any trench is backfilled or concrete is poured. Any work completed without such inspection is subject to rejection as unacceptable work and shall be immediately removed and acceptably replaced or otherwise satisfactorily corrected by and at the expense of the Contractor.

#### **601.6 Testing.**

The Contractor shall furnish all equipment and appliances necessary to test all installed cable systems. The Contractor shall test and demonstrate to the satisfaction of the Traffic Engineer that the lighting circuits are properly connected and operational; continuous and free from short circuits and unspecified grounds; that they are connected in accordance with the wiring layout; and that with fuses removed the resistance to ground of nongrounded circuits between any two adjacent terminals is not less than five (5) megohms.

All cable shall be "Meggered" and the results recorded. All values shall be in accordance with standard practice for the lengths and type of cable used. All electrical circuits and equipment shall be tested and remain in operating condition.

**601.7 Disposal of Excess Excavation.**

The Contractor shall be responsible for the disposal of any excess excavation. In the event the Contractor encounters stones, boulders, debris, or other material which would not normally be expected when excavating for lighting units or trenching for cable placement, the Contractor shall remove and dispose of such material as may be necessary.

**601.8 Tree Trimming.**

All tree trimming and incidental related work shall be performed by the Contractor under the supervision of the City Parks Division. The Contractor shall schedule the work to provide reasonable notification to the Parks Division (Forestry) of the tree trimming necessary and to further provide continuity of such work.

**601.9 Electrical Equipment.**

All electrical equipment shall provide suitable interchangeability and durability of performance and shall require the approval of the Traffic Engineer.

**601.10 Materials Furnished by the City.**

All materials which are to be furnished by the City shall be picked up by the Contractor at the Traffic Engineering Shop, 1120 Sayle Street, unless otherwise specified. All costs of the work included in this Section shall be at the expense of the Contractor unless otherwise provided. The Contractor shall provide equipment and labor to load materials onto Contractor's vehicle or trailer. Complete quantities of an item shall be picked up on one appointment unless the City agrees to a partial quantity disbursement.

## ARTICLE 602 - UNDERGROUND DISTRIBUTION SYSTEMS

---

### 602.1 General.

This item consists of installing underground signal cable and/or furnishing and installing an underground street lighting distribution system in accordance with these Specifications, the Special Provisions, and the details shown on the plans. Underground cable shall be pulled into existing and Contractor-installed conduit or installed as a cable-in-duct system as shown on the plans.

### 602.2 Materials.

#### 602.2(a) Cable-in-Duct.

1. Underground Cable Conductors. Unless otherwise specified, the underground cable system shall consist of three #4 AWG, cross-linked polyethylene insulated copper conductors, Type USE, RHH, RHW, 600 volt, paralleled with a single #8 AWG ground wire, assembled in a coilable polyethylene duct (cable-in-duct) and shall comply with the requirements of IPCEA-NEMA Standard S-66-524, and insulation thickness shall be nominal 0.060 of an inch.

Identification of the insulated conductors shall be accomplished by covering the insulation surface with a tough, strongly adherent colored coating in accordance with Method I or by surface printing in accordance with Method III of IPCEA-NEMA Standards S-19-81. White color coatings shall not be furnished or used on phase conductors.

Conductors shall be annealed copper unless otherwise specified. Conductor sizes 14-10 AWG may be solid or Class B stranding. Sizes 8 AWG and larger shall be Class B stranding. Conductors shall comply with the requirements of IPCEA-NEMA Standard S-19-81, Part 2.

The average insulation wall thickness shall be applied to the conductor with good concentricity. The minimum thickness of insulation at any point shall be not less than 90 percent of the specified average thickness.

2. Polyethylene Duct. The conductors shall be enclosed in a coilable polyethylene duct, suitable for direct earth burial, which shall meet the applicable requirements as defined in the Specifications for Polyethylene Molding and Extrusion Materials, ASTM D 1248, Type III, Class C.

The duct shall have a nominal size of 1-1/4 inches, approximate I.D. of 1.42 inches and a minimum wall thickness of 0.106 of an inch.

In addition, the duct shall meet the following requirements:

Property	Requirement	Test Method
Tensile Strength	2,800 PSI (min.)	ASTM D 638
Elongation	400% (min.)	ASTM D 638
Melt Index	0.50 (max.)	ASTM D 1238
Brittle Temperature - 80% Nonfailure	-60°C	ASTM D 746
Impact Resistance	.9 ft. #/in. of notch	ASTM D 256 Method

Part VI - Traffic Engineering Electrical

3. In lieu of the routine electrical tests described below, the Contractor shall furnish a manufacturer's certificate of compliance in triplicate for the insulated conductors and polyethylene duct, indicating their conformance with these Specifications.
4. The Contractor shall furnish manufacturer's certified test reports, in triplicate, to the Traffic Engineer indicating the conformance with these Specifications.

All tests included in these Specifications shall be performed in accordance with the test procedure and frequency described in IPCEA-NEMA Standard S-19-81, Part 6.

- a. High Voltage Test: Before installation in the polyethylene duct, each reel of the completed cable shall be immersed in water for a period of not less than six hours, and while immersed shall successfully withstand the application, for a period of five minutes, of a 60 cycle test voltage of the value specified in the standard.
- b. Insulation Resistance Test: Upon completion of the above specified high voltage test, the insulation resistance of each reel of completed cable shall be measured. The insulation resistance at, or corrected to, a temperature of 60°F shall be not less than that calculated from the expression:

$$R = 50,000 \log D/d$$

Where R = Insulation resistance, megohms - 1000 feet

D = Diameter over insulation - inches

d = Diameter under insulation - inches

602.2(b) Electrical Conduit.

1. Rigid Steel Conduit (commonly called GS conduit)

Rigid steel conduit (zinc coated) shall conform to the requirements of the American Standards Association Specifications for Rigid Steel Conduit, Zinc Coated, ANSI Designation: C 80.1, except with regard to identification and inspection. In addition to the manufacturer's name or trademark, as required by ANSI Designation: C 80.1, each length of conduit and nipple elbow shall have the Underwriters Laboratories, Inc. label, or an acceptable equivalent, firmly affixed.

2. Polyethylene Conduit

The conduit shall be either a medium density or high density grade polyethylene conduit suitable for direct earth burial. Medium density polyethylene shall meet the applicable requirements for Polyethylene Molding and Extrusion Materials, ASTM D-1248, Type II, Class C. High density polyethylene shall meet the applicable requirements for Polyethylene Molding and Extrusion Materials, ASTM D 1248, Type III, Class C.

The above materials shall also pass:

ASTM D 638: Tests for Tensile Strength and Elongation.

ASTM D 746: Brittle Temperature, 80% Non-failure.



ASTM D 1238: Test for Flow Rate.

The conduit shall correspond to the following dimensions:

Nominal Size	O.D.	I.D.	Min. Wall Thickness
1 in.	1.30 in.	1.05 in.	--
1-1/4	1.65	1.38	0.10 in.
1-1/2	1.90	1.61	--
2	2.37	2.06	0.15

The conduit shall be packaged on reels in accordance with industry standards.

3. Polyvinyl Chloride (PVC) Conduit (Schedule 40 and Schedule 80).

PVC conduit shall be used in accordance with the National Electrical Code and shall comply with all requirements in NEMA Specifications TC-2 (Conduit) and TC-3 (Fittings-UL-514), Federal Specification W-C-1094A, UL-651 (Standard for rigid nonmetallic conduit), and ANSI C33.91.

The conduit and fittings shall be clearly marked with a UL label. The type and manufacturer shall be identified by legible and permanent markings.

The conduit and fittings shall be produced by the same manufacturer and be homogeneous, virgin PVC C-300 compound free from visible cracks, holes or foreign inclusions. The conduit bore shall be smooth and free of blisters, nicks, or other imperfections which could mar conductors or cables.

All conduit and fittings shall be solvent welded in accordance with instructions from the manufacturer, and as directed by the Traffic Engineer. Solvent for welding PVC shall be clear, medium viscosity, with a fast set time, ASTM D 2564 or approved equal.

4. Conduit proposed for use shall be approved in writing by the Traffic Engineer prior to beginning work on the project.

The Contractor shall furnish manufacturer's certified test reports, in triplicate, to the Traffic Engineer indicating that the conduit proposed for use conforms to the above specifications.

602.2(c) Electrical Conductors.

Electrical conductors to be furnished shall be (size) AWG insulated conductors, Type USE, RHH, RHW as more fully described in Subsection 602.2(a)(1), or other typical electrical wire as specified.

**602.3 Construction Methods.**

602.3(a) Cable-in-Duct.

Cable-in-duct shall be installed in a trench and within the protection of Schedule 80 PVC conduit under all pavements and specified driveways, and in structures and in accordance with Subsection 602.3(c).

Cable-in-duct shall be installed within one (1) foot of the back of curb or as near as is practical to the back of curb as allowed by the engineer. It will, however, be the responsibility of the Contractor to locate all underground cable-in-duct in a manner to preclude damage to the cable or duct resulting from the subsequent construction. The wire part of the cable-in-duct assembly shall project at least two (2) feet above the top of each light base and the duct part shall extend 2" above the top of the raceway and be capped until the electrical connections are made within the light pole.

Under no circumstances shall cable ends be left uncovered or allowed to become submerged in water. Observations of either condition shall constitute sufficient grounds for rejection of the entire length of that cable.

The polyethylene duct which encases the wires shall be continuous to within six (6) inches of a terminal connection. Cable shall be installed in continuous lengths without splices from terminal to terminal. Splicing of cables will be permitted only in electrical handholes and electrical utility access structures, handholes in poles, and breakaway bases; or as otherwise provided in the plans.

The Contractor shall exercise care when installing the cable-in-duct to insure that the completed duct raceway is smooth and free of sharp bends and that the wires/cables inside the installed duct are "free" and capable of being easily removed and replaced.

Unless otherwise specified, all backfill shall be in accordance with the requirements of Section 502.1 of these Specifications. Native material will not be allowed for backfill if it is thirty (30) percent or more stones by volume. No rocks larger than four (4) inch diameter, stone aggregate, or any foreign debris shall be backfilled, unless otherwise approved by the engineer. When sand backfill is required, a six (6) inch minimum sand padding shall be used below the conduit and a six (6) inch minimum sand lift shall be used above the conduit.

#### 602.3(b) Electrical Conduit.

Electrical conduit, of size and type noted on the plans and/or in the Special Provisions, shall be installed in accordance with Subsection 602.3(c) at the locations specified, unless otherwise directed by the Traffic Engineer. In general, Schedule 80 PVC conduit shall be installed under commercial driveways and street pavements to provide protection for underground cable.

Each conduit run between access points to the wiring (e.g., handholes, electrical utility access structures, poles) shall be one size for its entire length. Electrical conduit shall be installed within one (1) foot of the back of curb or as near as practical to the back of curb, as allowed by the Engineer, when it is being placed parallel to the curb. It will, however, be the responsibility of the Contractor to locate all underground conduit in a manner to preclude damage to the duct resulting from subsequent construction. Where curb and gutter is being replaced, the new conduit to be installed parallel to the curb and gutter shall be placed according to the Typical Conduit Installation detail. When existing utilities preclude placing conduit as shown in the detail, the conduit shall be placed under the curb or as close to the curb as possible. When curb and gutter is not being replaced, the new conduit to be installed parallel to the curb and gutter shall be placed in the roadway, three feet from the edge of gutter, and as approved by the City Traffic Engineering Electrical Inspector.

For each conduit run in which cable will not be installed as part of the contract, the ends of the conduit shall be capped with standard conduit caps to preclude water and soil infiltration. If threaded caps are used, the threads shall be lubricated. Conduits terminating in a nonpaved location and not in

a structure shall be turned up and end at terrace finish grade with a PVC cap securely attached, as shown on Standard Detail 6.13).

All splices between reels of polyethylene conduit and connections to steel or PVC conduit shall be made with approved watertight coupling assemblies. Standard conduit fittings shall be used and all costs for couplings and joints shall be included in the unit price bid for the conduit.

When connections are to be made to an existing conduit, the Contractor shall first verify that the existing conduit is fully clear and useable for its entire cross-section and length. When the existing conduit is found to be defective, the Contractor shall notify the Inspector and not proceed until the Inspector so directs. If the Contractor connects to an existing defective conduit without the express direction from the Inspector, the Contractor shall make any and all necessary repairs and replacements to all conduits, including conduit that was "existing" prior to the Contractor starting work, in accordance with Section 601.4. All costs of this work shall be at the expense of the Contractor.

Unless otherwise specified, all backfill shall be in accordance with the requirements of Section 502.1 of these Specifications. Native material will not be allowed for backfill if it is thirty (30) percent or more stones by volume. No rocks larger than four (4) inch diameter, stone aggregate, or any foreign debris shall be backfilled, unless otherwise approved by the engineer. When sand backfill is required, a six (6) inch minimum sand padding shall be used below the conduit and a six (6) inch minimum sand lift shall be used above the conduit.

With prior approval from the Traffic Engineer, the Contractor may substitute a larger size of conduit than that specified for a run; however, any resulting additional costs shall be borne by the Contractor and no adjustment in compensation will be made.

Conduit to be placed under existing pavements, sidewalks and driveways shall be installed by pushing, gophering, or boring.

Entering existing manholes shall be made by watertight methods.

The location of each conduit under pavement shall be marked on the pavement or curb as shown on Standard Detail 6.11 or as directed by the Traffic Engineer.

Upon completion of the work under the contract, including roadway finishing operations, the Contractor shall, in the presence of the Traffic Engineer or Inspector, make an inspection of each installed conduit. A mandrel at least six (6) inches in length and of the proper size shall be used during the inspection to insure that the conduit is fully open for its entire length. The Contractor shall furnish all required tools, equipment and labor necessary to make the inspections. Any conduit found crushed or damaged, or determined by the Traffic Engineer to be unsatisfactory, shall be replaced by the Contractor at the Contractor's expense before the work will be accepted.

#### 602.3(c) Minimum Cover Requirement.

Conduit, duct, or other raceways shall be installed in accordance with the minimum cover requirements specified in the following table. Exceptions shall require the approval of the Traffic Engineer.

With prior approval, the required minimum cover may be reduced by six (6) inches for installations where a two (2) inch thick concrete pad, or equivalent in physical protection, is placed in the trench over the underground installation.

For the purposes of this subsection, “cover” is defined as the distance between the FINISHED grade and the TOP of the conduit, duct, or other raceway.

<b>MINIMUM COVER REQUIREMENTS (0 TO 600 VOLTS)</b>		
<b>WIRING METHOD</b>	<b>MINIMUM COVER (INCHES)</b>	
	<b>IN TERRACE OR UNDER SIDEWALK</b>	<b>ROADWAY</b>
Rigid Non-Metallic Conduit Approved for Direct-Burial without Concrete Encasement	30	24
Other Approved Raceways*	30	Not applicable
Within five feet of any handhole	40	Not applicable

\*Note: Encased Raceways shall require a concrete envelope not less than two (2) inches thick.

**602.3(d) Electrical Conductors.**

The proper type, size and number of electrical conductors as shown on the plans shall be installed. Installation methods shall conform to that described in Subsection 602.3(a) and other appropriate Subsections of these Specifications.

**602.3(e) Pull Wire.**

Unless specified or directed by the Traffic Engineer, a pull wire shall be installed in each conduit run in which cable will not be installed as part of the contract, including conduit connecting to existing conduit. The pull wire shall be a No. 10 AWG, or larger size, copper (insulated) TW wire approximately four (4) feet longer than the conduit run, and shall be doubled back for at least two (2) feet at each terminal.

The cost of pull wire shall be incidental to the cost of conduit unless specified otherwise on the plans and in the contract.

**602.3(f) Signal Cable.**

Signal cable will be furnished by the City. Following receipt of the cable by the Contractor at the Traffic Engineering Shop, 1120 Sayle Street, the Contractor shall be responsible for storage and handling and placing such cables as are specified on the plans. Signal cable not used in the project shall be returned by the Contractor to the Traffic Engineering Shop with no additional compensation for this work.

The Contractor shall install signal cable using acceptable trade methods and practices. When pulling cable into or out of electrical utility access structures and handholes, the Contractor shall use pulleys. The Contractor shall at all times exercise caution to protect the cable and its insulation from being damaged by sharp edges. Cable shall project at least two (2) feet above bases, except at the signal controller, where it shall project at least three (3) feet above the base. Under no circumstances shall cable ends be left uncovered or allowed to become submerged in water.

Cable shall be installed in continuous lengths without splices from terminal to terminal. Splicing of cables will be permitted only in electrical handholes and electrical utility access structures, handholes in poles, pole bases, or as otherwise provided in the plans.

#### **602.4 Measurement and Payment.**

##### **602.4(a) Cable-in-Duct.**

This item, complete in place and accepted, shall be measured in linear feet in a horizontal plane, from terminal connection to terminal connection along the center line of the trench or conduit with the terminal connection being the center line of the lighting unit base, electrical utility access structure, handhole, junction box or other terminal location as required by the plans and or specifications.

Additional lengths of cable necessary for making splices and connections at lighting units, junction boxes, distribution centers and other terminal locations shall be installed by the Contractor and considered as part of the work included in this item, but will not be measured or paid for directly.

The quantity, measured as provided above, will be paid for at the contract unit price per linear foot for cable-in-duct, which price shall be payment in full for furnishing all materials, unless otherwise indicated by the plans and Special Provisions; for trench work such as excavation, bedding and backfilling, including any sand, asphalt, concrete or other required materials, unless trench and backfill are specifically noted as separate bid items; for placing cable-in-duct; for making connections and testing installed cable systems; for disposal of surplus materials; for restoration of disturbed or damaged areas including seeding and sodding, unless general terrace restoration is required and is a separate bid item; for making inspections; and for all labor, tools, equipment and incidentals necessary to complete this item of work in accordance with the contract.

##### **602.4(b) Electrical Conduit.**

This item, complete in place and accepted, shall be measured in linear feet in a horizontal plane from terminal connection to terminal connection along the centerline of the trench or conduit, with the terminal connection being the centerline of the street light or traffic signal base, electrical utility access structure, handhole, junction box or other terminal location as required by the plans and specifications. The quantity measured for payment shall be the summation of linear feet of each size and type.

Additional lengths of conduit necessary for terminating conduit at or above grade shall be installed by the Contractor and considered as part of the work included in this item, but will not be measured or paid for directly.

The quantity, measured as provided above, will be paid for at the contract unit price per linear foot of each of the specified sizes and types, which price shall be payment in full for furnishing, hauling and placing the conduit, hangers, clips, fittings, and attachments; for trench work, such as excavation, bedding and backfilling, including any sand, asphalt, concrete or other required materials, unless trench and backfill are specifically noted as separate bid items; for furnishing and installing pull wire as required by Subsection 602.3(e); for drilling holes in manholes and resealing such openings after the conduit is installed; for disposal of surplus materials; for restoration of disturbed or damaged areas including seeding and sodding, unless general terrace restoration is required and is a separate bid item; for making inspections; and for all labor, tools, equipment and incidentals necessary to complete this item of work in accordance with the contract.

The quantity of conduit installed by pushing, gophering, or boring, measured as provided above, will be paid for at the contract unit price per linear foot of each of the specified sizes, which price shall be payment in full for furnishing, hauling and placing the conduit and fittings; for securing all necessary permits; for all necessary excavation, bedding and backfilling, including any sand, concrete or other required materials; for restoration of disturbed or damaged area including seeding and sodding, unless general terrace restoration is required and is a separate bid item; for disposal of surplus materials; for making inspections; and for furnishing all labor, tools, equipment and incidentals necessary to complete the work. Item 60241, Gopher Raceway, shall include any and all work associated with determining locations of existing utilities, such as underground locates. Item 60241 shall include raceways created by pushing, gophering or boring. The measured quantity will only include distances installed directly underneath curb and gutter, roadway, and sidewalk sections that are not removed or constructed with this project. Minor alterations in conduit location may be made by the City Traffic Engineering Electrical Inspector to avoid gopher installation.

**602.4(c) Electrical Conductors and Signal Cable.**

This item, complete in place and accepted, shall be measured in linear feet in a horizontal plane, from terminal connection to terminal connection along the center line of the trench or conduit with the terminal connection being the center line of the signal or light base, electrical utility access structure, handhole, junction box or other terminal location as required by the plans and/or specifications.

Additional lengths of cable or conductors necessary for making splices and connections at signal bases and other terminal locations shall be installed by the Contractor and considered as part of the work included in this item, but will not be measured or paid for directly.

The quantity of cable installed, measured as provided above, will be paid for at the contract unit price per linear foot, which price shall be payment in full for storing, handling, transporting, and installing; for furnishing all labor, tools, equipment and incidentals necessary to complete this item of work.

**602.5 Electrical Trench.**

**602.5(a) Construction Methods.**

This item consists of excavating, bedding, and backfilling a trench in roadways and terraces for electrical conduit installation. The width of the trench shall be sufficient to accommodate the conduit installations shown on the plan without stacking the conduits. The trench shall be excavated true to line and to provide a 30 inch depth for conduit, except as otherwise authorized by the Engineer in the field. Backfill shall be carefully and adequately compacted in place. In most cases, the surface restoration will be provided as a part of the general roadway contract work.

Unless otherwise specified, all backfill shall be in accordance with the requirements of Section 502.1 of these Specifications. Native material will not be allowed for backfill if it is thirty (30) percent or more stones by volume. No rocks larger than four (4) inch diameter, stone aggregate, or any foreign debris shall be backfilled, unless otherwise approved by the engineer. When sand backfill is required, a six (6) inch minimum sand padding shall be used below the conduit and a six (6) inch minimum sand lift shall be used above the conduit.

602.5(b) Method of Measurement.

Electrical trench, complete and accepted, shall be measured by length in linear feet, in a horizontal plane along the center line of the trench.

602.5(c) Basis of Payment.

The quantity of trench, measured as provided above, will be paid for at the contract unit price per linear foot, or as part of conduit or cable-in-duct installation if a separate bid item for electrical trench is not provided, which price shall be payment in full for excavating, bedding, and backfilling, excluding any select fill as required in Article 202 of these Specifications but including sand or other required materials; for surface restoration with topsoil and seed where not otherwise provided in this contract; for disposal of surplus materials; for making inspections; and for furnishing all materials; labor, tools, equipment, and incidentals necessary to complete the work.

## **ARTICLE 603 - REMOVAL OF AERIAL DISTRIBUTION SYSTEMS**

---

### **603.1 General.**

This item consists of removing an existing aerial electrical distribution system for street lighting in accordance with these Specifications, the Special Provisions, and the details shown on the plans.

### **603.2 Construction Methods.**

The Contractor shall remove existing aerial cable in such a manner as to maintain service to existing street lights. The Contractor shall remove existing aerial cable and its appurtenances from existing street light standards as noted on the plans and/or in the Special Provisions. Rewiring of the street light standard, if required, shall be performed in accordance with Article 605 of these Specifications.

### **603.3 Measurement and Payment.**

This item shall be measured as a lump sum, with aerial cable and its appurtenances completely removed from existing lighting standards and with all lighting systems outside of the project area remaining in operation.

This item, measured as provided above, will be paid for as a lump sum, which price shall be payment in full for disposal of surplus materials and for all labor, tools, equipment, and incidentals necessary to complete this item of work in accordance with the contract.



## **ARTICLE 604 - BASES FOR STREET LIGHTING UNITS AND TRAFFIC SIGNAL STANDARDS AND CONTROLLERS**

---

### **604.1 General.**

This item consists of constructing concrete bases with the necessary hardware for traffic signal standards, controllers, and street lighting units in accordance with these Specifications, the applicable Standard Plate for the base involved, the Special Provisions, and the details shown on the plans.

### **604.2 Materials.**

All requirements specified in Article 301 - Concrete and Concrete Materials, regarding mix design, high-early strength concrete, testing, materials, mixing, placing, curing, and protecting the concrete, shall apply to the concrete used in the construction of said bases.

### **604.3 Construction Methods.**

Where bases are to be installed within existing sidewalks or improved terraces, the Contractor shall remove and replace the entire stone of sidewalk or improved terrace affected by the installation unless otherwise specified or directed by the Traffic Engineer.

The general locations of the bases are shown on the plans. The exact locations and elevations shall be established in the field by the Traffic Engineer. Unless otherwise specified, bases shall be placed with one side parallel to the center line of the street and the center of the base shall be four (4) feet from the face of the curb. The elevations of the bases shall be as shown on the applicable Standard Plate unless otherwise specified.

Forms shall be placed with sufficient depth to provide a minimum of twelve (12) inches of formed base below the finished grade on the low side of the base. The top surface of the base shall be level, with a three-fourths (3/4) inch bevel on the edges, and given a float finish.

A five-eighths (5/8) inch by eight (8) foot copper-weld ground rod shall be cast into each base. The ground rod shall extend a minimum of seven (7) feet below the bottom of the base and shall be connected with a No. 4 stranded copper wire and approved connector to one anchor bolt. The No. 4 stranded copper wire shall be of sufficient length to protrude three (3) feet above the top of the base for the Contractor to connect the wire to the ground lug in the pole or metal base.

City-furnished anchor bolts shall be cast into the base. These bolts shall be placed in accordance with the base detail and other directions furnished by the City as to location and projection above the top of the base, and shall be true vertical. All anchor bolts 1" diameter and larger shall be placed in the form before concrete is poured. The bolts shall be secured by tack welding or wiring horizontal rebar to the bolts to form an anchor bolt cage. The horizontal rebar shall be placed 18" from the top and 12" from the bottom of the bolts.

The Contractor shall furnish and install a minimum of two manufactured elbows in all bases and more where specified. The contractor shall install the elbows to permit cable entrance from the street side of, or along the line of, the poles, as shown on the plans. Manufactured galvanized steel elbows with grounding bushings shall be furnished and installed in those bases where galvanized steel conduit is used, as shown on the plans. Existing conduit shall be extended into the bases. The conduit extending above the concrete base shall be centered.

Unless otherwise specified, all backfill shall be in accordance with the requirements of Section 503.2 of these Specifications.

#### **604.4 Measurement and Payment.**

These items shall be measured as units, complete in place and accepted in accordance with the contract.

These items, measured as provided above, will be paid for at the contract unit price for each of the various types of bases, which price shall be payment in full for furnishing and installing reinforcing rods, conduit elbows, clamps, ground rods, and copper wire; for picking up and installing anchor bolts; for furnishing and placing concrete masonry; for excavation, backfill, and disposal of surplus materials; and for all labor, tools, equipment and incidentals necessary to complete these items of work.

#### **604.5 Removal of Existing Street Light Pole, Traffic Signal Poles and Cabinets, and Miscellaneous Electrical Bases and Abandoning Handholes and Electrical Utility Access Structures.**

##### **604.5(a) Description.**

This work shall consist of removing, wholly or in part, street light bases, poles, arms and fixtures and concrete bases for fire alarm pedestals, traffic signal poles and traffic signal cabinets; and abandoning handholes and electrical utility access structures.

##### **604.5(b) Construction Methods.**

The Contractor shall remove those street light pole (poles, arms, metal base, and fixtures), traffic signal pole (including metal base and other attachments), traffic signal cabinet, and other miscellaneous electrical bases, and shall abandon handholes and electrical utility access structures as identified on the plan or by the Engineer. All street light poles, metal base, arms, fixtures, traffic signal poles, traffic signal cabinets, and all handhole and electrical utility access structure frames and covers removed by the Contractor, shall be delivered to the Traffic Operations Shop, 1120 Sayle Street, unless designated by the Engineer to be reinstalled in the project area or not returned to the City. The Contractor shall dispose of old concrete bases at a site provided by the Contractor.

Abandon Electrical Utility Access Structures (also known as manholes), shall consist of the following:

1. Removing the concrete roof and the top three feet of walls.
2. Breaking the floor to promote drainage; the maximum unbroken floor size shall be two-foot by two-foot.
3. Backfill and compact with sand fill.
4. Remove and return the steel frame and cover to TE Shop, 1120 Sayle Street.

**604.5(c) Method of Measurement.**

Removing street light pole, traffic signal pole, traffic signal cabinet, and miscellaneous electrical bases and abandoning handholes and electrical utility access structures will be measured as units. A traffic signal control cabinet base shall be considered a traffic signal base for measurement.

**604.5(d) Basis of Payment.**

The contract unit price for removal of street light pole shall be payment in full for removing the fixture, arm, metal base, and pole; and transporting/storing/disposing of materials as previously provided in these Specifications; and for furnishing all labor, tools, equipment, and incidentals necessary to complete the work. The Contractor shall be responsible for any damage to the street light fixtures, metal bases, and poles during removal, reinstallation and return.

The contract unit price for removal of traffic signal pole and traffic signal cabinet shall be payment in full for removing the equipment and transporting/storing/disposing of the materials as previously provided in these Specifications; and for furnishing all labor, tools, equipment, and incidentals necessary to complete the work. The Contractor shall be responsible for any damage to the existing equipment during removal, reinstallation, and return.

The contract unit price for miscellaneous electrical base removal shall be payment in full for removing and disposing of the bases as provided in the Specifications; and for furnishing all labor, tools, equipment, and incidentals necessary to complete the work.

The contract unit price for abandoning handholes and electrical utility access structures shall be payment in full for removal and return of the frame and cover, as provided in these Specifications; for backfilling the handhole or electrical utility access structure to be abandoned; and for furnishing all labor, tools, equipment, and incidentals necessary to complete the work.

**604.6 Auger Street Light Base.**

**604.6(a) Description.**

The work under this item shall consist of augering one or two holes in a concrete street light base to provide a raceway for designated duct in and out of the base.

**604.6(b) Method of Measurement.**

Auger Street Light Base will be measured by the number of bases so augered.

**604.6(c) Basis of Payment.**

The contract unit price for Auger Street Light Base shall be payment in full for providing necessary entrance and exit for designated ducts at existing street light bases and for furnishing all labor, tools, equipment and incidentals necessary to complete the work.

## **604.7 Base for Multi Space Parking Meters.**

### **604.7(a) Description.**

This item consists of picking up and installing city provided steel bases for multi space parking meters in accordance with these Specifications, the Special Provisions, and the Standard Detail shown on the plans.

### **604.7(b) Materials.**

All requirements specified in Article 301 - Concrete and Concrete Materials, regarding mix design, high-early strength concrete, testing, materials, mixing, placing, curing, and protecting the concrete, shall apply to the concrete used in the construction of said concrete slab around said bases.

### **604.7(c) Construction Methods.**

Where bases are to be installed within existing sidewalks or improved terraces, the Contractor shall remove and replace the entire stone of sidewalk or improved terrace affected by the installation unless otherwise specified or directed by the Engineer.

The general locations of the bases are shown on the plans. The exact locations and elevations shall be established in the field by the Parking Utility Maintenance Supervisor (Dan Valenza, 266-4744). Unless otherwise specified, bases shall be placed with one side parallel to the center line of the adjacent sidewalk and the center of the base shall be four (4) feet from the face of the curb. The elevations of the bases shall be as shown on the detail unless otherwise specified.

The city-furnished steel base shall be cast into the concrete sidewalk slab. The top of the steel base shall be level, with a minimum depth of two inches below the finished slab grade. Aggregate shall be compacted around the base to ensure that the base does not rock. The parking Utility will provide a reusable 13" X 20" wooden form attached to the top of the base. A representative from the Parking Utility or a designee from Traffic Engineering must approve the installation before the concrete pour. Contact the Parking Utility Maintenance Supervisor (Dan Valenza, 266-4744) 48 hours in advance prior to the concrete pour to set up a time for approval.

The concrete must be vibrated on the two open ends of the base and through the six 2.25" openings on the sides. Any bases that have insufficient compaction of aggregate or insufficient penetration of concrete into the base leading to the base rocking once a multi space meter is installed shall be removed and replaced at contractor's expense, including replacement of the entire concrete slab.

No concrete shall be allowed to extend over the top surface of the steel base.

The contractor shall install conduit as shown in the plan. Conduit shall extend three inches above the top of the steel base plate.

Unless otherwise specified, all backfill shall be in accordance with the requirements of Section 503.2 of these Specifications.

### **604.7(d) Measurement and Payment.**

This item shall be measured as units, complete in place and accepted in accordance with the contract.

## Part VI - Traffic Engineering Electrical

This item, measured as provided above, will be paid for at the contract unit price for each base, which price shall be payment in full for picking up and installing the city provided steel plate in the concrete slab and placing the concrete slab; for excavation, backfill, and disposal of surplus materials; and for all labor, tools, equipment and incidentals necessary to complete these items of work.

## **ARTICLE 605 - INSTALLATION OF STREET LIGHTING UNITS**

### **605.1 General.**

This item consists of installing luminaires, lamps, and metal or precast concrete poles as complete street lighting units in accordance with the Plans, these Specifications and the Special Provisions.

Lighting units shall be grouped to operate from branch circuits which are energized by lighting contactors remotely controlled by photocell. Where a system is employed, no individual lighting units shall be controlled by photocells or time switches. Time switches control only the removal from service of the midnight and 3:00 a.m. circuits.

Each system shall be wired in a manner that presents as near as is possible a balanced load at the source of supply during midnight, or 3:00 a.m. operation and all-night operation.

### **605.2 Construction Methods.**

#### **605.2(a) General.**

Conductors to each luminaire from the bottom of the pole shall be two No. 14 solid annealed copper, UF, 600 volt, as manufactured by General Cable, Anaconda, Rome, Kaiser, or approved equal. On all systems, the phase wire at the pole handhole shall have a secondary in-line fuse assembly, Series 64, as manufactured by Elastic Stop Nut Corporation of America, Buss Tron HEB-AA fuseholder, or approved equal, with a Bussmanteype FNM or FNQ fuse of the required size (refer to the following table).

<b>REQUIRED SIZE - IN-LINE SECONDARY FUSES</b>					
<b>VOLTAGE</b>	<b>LUMINAIRE WATTAGE</b>				
	<b>400W</b>	<b>250W</b>	<b>200W</b>	<b>150W</b>	<b>100W or less</b>
480V	2 amp	2 amp	2 amp	2 amp	2 amp
240V	5 amp	3.2 amp	2 amp	2 amp	2 amp
120V	6.25 amp	5 amp	5 amp	3.2 amp	2 amp

The phase wire shall not be spliced between the fuse assembly and luminaire. A sufficient length of No. 12 conductor shall be installed in the pole to permit removal of this fuse-holder through the handhole before disconnecting.

A 24" length of #12 THHN Stranded Conductor tail shall be installed to supply wires permitting easy removal of fixture wires and fuse holder through the handhole. A tail of #4 wire from the neutral conductor splice shall be grounded to each ground rod and metal street light pole. The following color coding shall be used at all street light bases: Midnight Circuit (red), all night circuit (black), and neutral (white). Electrical splices and connections shall be electrically secure and made with pressure or compression fittings as manufactured by Thomas & Betts, Burndy, 3-M (scotch lock brand) or approved equal and used as recommended by the engineer. Taps and splices shall be protected in the following manner: all wire connections shall be coated with No-Lox Compound; taps and splices made with irregularly shaped connectors shall first be built up with insulating material, "Air Seal" #18415 manufactured by Kearney or approved equal; all sharp corners and voids shall be filled; over this, install 3 half lapped layers of rubber electrical tape, dielectric strength, 300 volts per mil - self vulcanizing tape, installed as per manufacturer's instructions; over this, apply 3 half lapped layers Scotch Brand 33 Plus or approved equal, vinyl plastic electrical tape; then dip the entire splice 1"

beyond the insulating material in Scotch-Kote or approved equal. The constructed splice shall be allowed to air dry completely before insertion into the street light pole. All wires leaving the splice shall be in one direction. Split bolts, when used, shall be hammered and retightened three times and a spacer shall be provided between any copper and aluminum conductors. The fuse holder shall be connected to the All-Night circuit or Midnight circuit as indicated on the plans with an approved wire nut (3M or Ideal). The wire nut shall be dipped in Scotch-Kote or approved equal.

The lighting units shall be connected with the underground or overhead cable, as is applicable, and shall provide a complete, operational system when finished.

**605.2(b) Metal Pole.**

Metal poles shall be set and plumbed with the use of leveling nuts furnished with the anchor bolts. Luminaires shall be leveled after erecting and leveling the metal standards with bracket arms. The proper leveling method may be obtained from the manufacturer's instruction manual. Nuts on anchor and transformer bolts shall be torqued to 175-200 foot pounds or as directed by the Engineer. Rust, corrosion, and anti-seize protection shall be provided at all threaded assemblies by coating and mating surfaces with Markal (Hightemp-E-Z Break), Never-Seez (Marine Grade), LPS 100, Lubriplate, or approved equal.

The stranded copper ground wire that is installed as a part of base construction shall be attached with an approved connector (Fargo GC 202 or approved equal) to a ground nut located inside the pole and opposite the handhole.

Grout shall be troweled between the pole and concrete base and finished at an angle from the edge of the pole base to the outer edge of the foundation. A 1/2 inch slot for drainage shall be left through the grouting on the street side at the top of the concrete base. The grout shall be Patch-crete (manufactured by Ready-Crete of Milwaukee, Wisconsin) or approved equal.

**605.2(c) Precast Concrete Butt-Base Pole.**

The Contractor shall install the pole in an augered or hand-dug hole and shall tamp the pole securely in a plumb position using six (6) inch lifts of select salvage material. When debris is present in the salvage material to such an extent that in the Traffic Engineer's opinion good compaction cannot be obtained, material specified by the Traffic Engineer shall be used as fill.

If a bracket-arm type of installation is required, the luminaire shall be leveled after the pole has been securely tamped in a plumb position.

The Contractor is responsible for maintaining the pole in a plumb position until the project is accepted by the Common Council.

A typical detail of City-furnished precast concrete butt-base poles is shown on Standard Plate 6.05.

**605.3 Measurement and Payment.**

This item shall be measured as units in place, completely installed and accepted in accordance with the contract.

## Part VI - Traffic Engineering Electrical

This item, measured as provided above, will be paid for at the contract unit price, which price shall be payment in full for picking up and installing City-furnished material including transformer or breakaway bases and devices; for furnishing and installing fuses, wire and all miscellaneous hardware necessary to integrate the components into a single unit connected to the feeder system; and for all labor, tools, equipment and incidentals necessary to complete this item of work.



## **ARTICLE 606 - INSTALLATION OF METERED OR UNMETERED ELECTRIC SERVICE**

---

### **606.1 General.**

This work consists of installing metered or unmetered electric service in accordance with the Special Provisions, these Specifications, the applicable Standard Plates, and the details shown on the plans.

### **606.2 Construction Methods.**

The Contractor shall install a City-furnished pre-wired control cabinet on the pole or base specified and, unless specified otherwise, install a City-furnished photoelectric cell on the luminaire closest to the control cabinet.

The Contractor shall install a two (2) inch conduit or base elbow when applicable for the electric utility to install an underground service as shown on the Standard Plate.

The Contractor shall install two 5/8" x 8' copper ground rods, with six (6) foot minimum horizontal spacing, connecting them with a No. 4 copper wire using ground clamps. Ground rods and connection wire shall have thirty (30) inch minimum ground cover. No. 4 wire shall be continuous and extend up the outside of two (2) inch G.S. conduit to control panel and connect to the ground buss on the main disconnect.

Wiring of the photoelectric cell shall be internal for a steel or precast concrete pole and within a Contractor-furnished and installed metal conduit for a wood pole installation. The wiring shall be done with 3 conductor No. 14 UF cable.

The Contractor shall obtain the electrical permits necessary for this work from the Building Inspection and Rehabilitation Unit of the City Department of Planning and Development.

### **606.3 Measurement and Payment.**

This item shall be measured by the unit complete and operational in place and accepted in accordance with the contract.

This item, measured as provided above, will be paid for at the contract unit price, which price shall be payment in full for furnishing wire, ground rods, ground clamps, and galvanized steel conduit; for picking up and installing the City-furnished control cabinet and photoelectric cell; and for all labor, tools, equipment and incidentals necessary to complete this item of work.

## **ARTICLE 607 - ELECTRICAL UTILITY ACCESS STRUCTURES, ELECTRICAL HANDHOLES AND BOX-OUTS**

---

### **607.1 General.**

This work consists of constructing electrical utility access structures, electrical handholes and box-outs in accordance with details shown on the plans and in accordance with these Specifications and the applicable Standard Plate for the structure involved.

All materials used in construction of electrical utility access structures, electrical handholes and box-outs shall conform to the requirements for the various types of materials contained in these Specifications.

Electrical Handhole, Type I shall be gray colored polymer concrete construction. Box dimensions for Type I shall be 19" wide X 32" long X 24" deep and come with a cover rated to withstand 15,000 lbs over a 10" square with a minimum test load of 22,568 lbs. Electrical Handhole, Type III, shall be 12" x 12" x 12". The box and cover shall be rated to withstand 20,000 lbs. Electrical Handhole, Type V, shall be gray colored polymer concrete construction. Box dimensions shall be 26" wide by 38" long by 24" deep. The box and cover shall be rated at 15,000 lbs over a 10" square with a minimum test load of 22,568 lbs.

### **607.2 Construction Methods.**

Unless otherwise specified, all backfill shall be in accordance with the requirements of Section 502.1 of these Specifications.

### **607.3 Measurement and Payment.**

These items shall be measured as units complete in place and accepted in accordance with the contract.

These items, measured as provided above, will be paid for at the contract unit price for each, which price shall be payment in full for furnishing and installing all materials necessary to complete the installation, including excavation, backfill and disposal of surplus materials; and for all labor, tools, equipment and incidentals necessary to complete these items of work.

## **ARTICLE 608 - PAVEMENT MARKINGS**

---

### **608.1 Description**

This section describes the furnishing and applying, or removing, of pavement markings.

### **608.2 General Requirements**

All aspects of the current edition of the Wisconsin Department of Transportation Standard Specifications, Part 6 Section 646 & Section 647 as they pertain to the bid items within this section, except for the measurement of items described in the following section, shall apply.

Acceptable performance of pavement markings will be evaluated during the proving period in sections. Each solid line, double line, or dotted line, measured through 600 foot length will be considered a section. Intersection markings including solid lines, groupings of diagonal lines, stop lines, crosswalks, median nose, symbols, and words or miscellaneous markings including parking stalls will be evaluated separately as a section.

### **608.3 Method of Measurement**

608.3(a) Median Nose.

Shall be measured by the square foot of material applied.

608.3(b) Double Line, 4-Inch.

Shall be measured per linear foot of two(2) 4" lines of material applied/removed.

608.3(b) Bike Lane & Straight Arrow.

Shall be combined and measured as a unit of each.

608.3(b)

Removal of lines shall be measured per linear foot and width of material removed.

## **ARTICLE 609 - TEMPORARY PAVEMENT MARKINGS.**

---

### **609.1 Description**

This section describes the furnishing and applying, or removing, of temporary pavement markings.

### **609.2 General Requirements**

All aspects of the current edition of the Wisconsin Department of Transportation Standard Specifications, Part 6 Section 649 as they pertain to the bid items within this section shall apply.

## Part VII - Water Mains and Service Laterals

ARTICLE 701 - GENERAL.....	1
701.1    Definition.....	1
701.2    General.....	1
701.3    Emergency Contact.....	1
ARTICLE 702 - MATERIALS .....	2
702.1    General.....	2
702.2    Equipment.....	2
702.3    Ductile Iron Water Main & Accessories.....	2
702.4    Fittings & Accessories.....	3
702.5    Services and Stops & Accessories.....	4
702.6    Disinfection Chemicals.....	6
ARTICLE 703 - CONSTRUCTION METHODS .....	8
703.1    General.....	8
703.2    Installation Tolerance.....	8
703.3    Repairs and Alterations:.....	9
703.1    Excavation.....	10
703.2    Temporary Support.....	11
703.3    Backfilling.....	12
703.4    Connecting to Existing Water Mains.....	15
703.5    Water Main Shutoffs.....	15
703.6    Mechanical Joint Pipe and Fittings.....	16
703.7    Thrust Restraint.....	16
703.8    Polyethylene Encasement.....	18
703.9    Copper Service Laterals.....	19
703.10    Disinfection.....	20
703.11    Flushing.....	20
703.12    Testing.....	22
703.13    Finishing Work and Maintenance.....	25
703.14    Final Inspection.....	26
703.15    Water Utility Construction Services.....	26
ARTICLE 704 – BID ITEMS, MEASUREMENT AND PAYMENT .....	27
704.1    General.....	27
704.2    Bid Items.....	27
704.3    Furnish & Install Pipe & Fittings.....	28
704.4    Horizontal Directional Drill Pipe.....	31
704.5    Furnish & Install Casing.....	34
704.6    Furnish & Install Water Valve.....	36
704.7    Furnish and Install Hydrant.....	39
704.8    Relocate Hydrant.....	42
704.9    Furnish & Install Water Service Laterals.....	43
704.10    Replace Service Lateral.....	45
704.11    Extend and Reconnect Service Lateral.....	46
704.12    Disconnect / Reconnect Service Lateral.....	47
704.13    Select Fill – Sand for Water.....	48

704.14	Cut-In <b>or Connect-To Existing Water System</b> .....	49
704.15	Furnish Excavation and Ditch for Live Tap.....	50
704.16	Cut Off Existing Water Main.....	51
704.17	Abandon Water Valve Box.....	52
704.18	Abandon Hydrant.....	53
704.19	Abandon Water Valve Access Structure.....	54
704.20	Furnish and Install Styrofoam.....	55
704.21	<b>Landscape</b> Restoration for Water Main.....	56
704.22	Water Valve Access Structure.....	57
704.23	Adjust Water Valve Box.....	58
704.24	Pipe Plug for Water Main Installation.....	59
704.25	Rock Excavation.....	60
704.26	Removal of Excess Amounts of Boulders.....	62
704.27	Additional Excavation.....	63
704.28	Undercut.....	64
704.29	Adjust Water Service Box.....	65
704.30	Furnish and Install Curb Box.....	66
704.31	Furnish and Install Curb Stop.....	67
704.32	Abandon Existing Curb Box.....	68

## **ARTICLE 701 - GENERAL**

---

### **701.1 Definition.**

- (1) Whenever the term “Engineer” is used with respect to water main or water service lateral construction, it shall be understood to include the General Manager of the Madison Water Utility and all duly authorized representatives thereof.
- (2) All other definitions as described in Article 101.

### **701.2 General.**

- (1) Unless otherwise ordered by the Engineer, specified in the Contract Documents or shown on the approved drawings, conform to the requirements of the Specifications herein. In case of discrepancy, conform to the hierarchy as described in Article 104.

### **701.3 Emergency Contact.**

- (1) Furnish the Engineer with a local telephone number where a duly authorized representative can be contacted in case of an emergency at night or on weekends.

## **ARTICLE 702 - MATERIALS**

---

### **702.1 General.**

- (1) Conform to the requirements specified herein for the type and class of material named. The Engineer reserves the right to reject any materials not meeting these Specifications as being defective.
- (2) Prior to use, obtain approval in writing from the Engineer for any proposed substitutions of equivalent material.
- (3) Ensure that the manufactured year of all materials is the current or previous year.
- (4) Inspect all materials when delivered to the job site. Promptly remove from the worksite any materials that are rejected by the Engineer due to cracks, flaws, or other defects. The City will not be held liable for project delays that occur due to rejected materials.
- (5) Unload, haul, and distribute all materials near their respective point of installation. Unload any City-furnished pipes and accessories in an area that is deemed acceptable to the Engineer as accessible and convenient to the job site. Handle the materials with care to avoid damage. Do not drop or bump materials against the ground.

### **702.2 Equipment.**

- (1) Ensure that all equipment and tools necessary for performing any specified work are satisfactory to design, capacity, and mechanical condition for the purposes intended.
- (2) Repair, improve, replace and/or supplement any equipment which is not maintained in full working order, or which as used is inadequate to obtain the results prescribed by the Contract Documents.
- (3) Use of any unpowered hand tools is considered incidental.

### **702.3 Ductile Iron Water Main & Accessories.**

#### **702.3.1 Ductile Iron Pipe:**

- (1) Ductile iron pipe and accessories shall conform to the requirements of American National Standard for Ductile Iron Pipe, Centrifugally Cast, for Water (ANSI/AWWA C151/A21.51 - latest revision).
- (2) Pipe requirements:
  1. Class 52 ductile iron.
  2. Cement lined.
  3. Push-on joint.
  4. Furnished with all necessary accessories.
  5. Bonding straps to provide electrical conductivity without field welding.



### **702.3.2 Gaskets:**

- (1) Gaskets shall conform to the requirements of American National Standard for Rubber-Gasket Joints for Ductile Iron Pressure Pipe and Fittings (ANSI/AWWA C111/A21.11 - latest revision).
- (2) Gasket Requirements:
  1. Plain rubber gaskets.
  2. Restrained-joint locking gaskets.
    - i. Use restrained joint locking gaskets when electing to *or* are otherwise required to meet thrust-restraint requirements by means of restrained-joint pipe.
    - ii. Restrained-joint locking gaskets must be certified as compliant for use with the furnished pipe material by the pipe manufacturer.

### **702.3.3 Polyethylene Encasement:**

- (1) Polyethylene encasement materials shall conform to the requirements of the American National Standard for Polyethylene Encasement for Ductile Iron Pipe Systems (ANSI/AWWA C105/A21.5 - latest revision).
- (2) Polyethylene Encasement Requirements:
  1. 8-mil thickness (minimum).
  2. Furnish in either tube or sheet form.

## **702.4 Fittings & Accessories.**

### **702.4.1 Mechanical Joint Fittings:**

- (1) Mechanical joint fittings are to conform to the requirements of American National Standard for Ductile Iron and Gray Iron Fittings, 3-inch through 48-inch, for Water (ANSI/AWWA C110/A21.10 - latest revision).
- (2) Mechanical Joint Fitting Requirements:
  1. Class 250 mechanical joint pipe fittings.
  2. Cement lined.
  3. All bells.
  4. Entire fitting tarred.
  5. Conductive mechanical joint (no lead)
  6. Furnished with all necessary accessories (rubber gaskets, flanges, bolts, etc.).

### **702.4.2 Mechanical Joint Restraints:**

- (1) EBAA Iron Inc. - MEGALUG® Series 1100, or approved equal.

**702.4.3 Nuts and Bolts:**

- (1) Comply with AWWA C111/A21.11. - latest revision.
- (2) Ensure that bolts are of sufficient length such that a minimum of ½-inch of threads are exposed beyond the end of the nut when tightened.
- (3) Refer to the following table for the numbers, diameters, and lengths of bolts to be used:

<b>Pipe Diameter (inches)</b>	<b>No. of Bolts Required</b>	<b>Bolt Diameter (inches)</b>	<b>Bolt Length (inches)</b>	<b>Bolt Length for MEGALUG® (inches)</b>
3	4	5/8	3	3-1/2
4	4	3/4	3-1/2	4
6	6	3/4	3-1/2	4
8	6	3/4	4	4-1/2
10 - 12	8	3/4	4	4-1/2
14	10	3/4	4-1/2	5
16 - 18	12	3/4	4-1/2	5
20	14	3/4	4-1/2	5

**702.4.4 Solid Sleeves:**

1. Class 52 ductile iron.

**702.4.5 Repair Sleeves:**

- (1) Repair sleeves may only be used when solid sleeves will not fit over existing pipe without major modification, such as significant grinding of pipe.
- (2) Allowable Repair Sleeves:
  1. Rockwell 441.
  2. Ford FCI Bolted Flex Coupling.
  3. Powerseal 3501.

**702.5 Services and Stops & Accessories.**

**702.5.1 Service Laterals:**

- (1) 2-inch diameter and smaller laterals:
  1. Type K soft copper tubing.
  2. Straight length sections for 1½ -inch and 2-inch sizes.
- (2) 4-inch diameter and larger laterals:
  1. Class 52 ductile iron

2. See Article 702 – Ductile Iron Water Main & Accessories.

**702.5.2 Saddles:**

- (1) Saddles are required at:
  1. All 1-1/2-inch and 2-inch service lateral taps.
  2. All service lateral taps on PVC, HDPE, or CIPP-lined water mains.
- (2) Approved saddles:
  1. Ford Series 202B double strap brass saddle.
  2. A.Y. McDonald - Series 3825 saddles (double strap).

**702.5.3 Couplings:**

- (1) Couplings shall be copper-to-copper fittings.
- (2) Compression couplings are only permitted when reconnecting existing copper tubing to new copper tubing.
- (3) Allowable couplings:
  1. Mueller H15400.
  2. Mueller H15405.
  3. Mueller H5403.
  4. Mueller P15403.
  5. Ford C44-33 / 44 / 66 / 77

**702.5.4 Corporation Stops & Service Fittings:**

- (1) 1-inch diameter Corporation Stops:
  1. Mueller H – 9971.
- (2) 1½-inch and 2-inch diameter Corporation Stops:
  1. Mueller H – 10003.
- (3) 1-inch diameter Service Fitting (1/8 bends):
  1. Mueller H – 15485.
- (4) 1½-inch and 2-inch diameter Service Fittings (1/8 bends):
  1. Mueller H – 15470.
- (5) Supply all Service Fittings (1/8 bends) with a fiber gasket.

**702.5.5 Curb Stops:**

- (1) 1-inch diameter Curb Stops:
  1. Mueller H1502-2.
- (2) 1 ½-inch and 2-inch diameter Curb Stops:
  1. Mueller H15201.

**702.5.6 Curb Boxes:**

- (1) Ensure that all curb boxes are complete, with covers marked “WATER.”
- (2) Curb Box Assemblies shall include the following:
  1. Brass screws.
  2. 2½-inch new style flush fit cover.
  3. 54-inch rods and guide rings.
  4. 2½-inch screw type shaft.
  5. 37-inch bottom section.
  6. 29-inch top section.
  7. 16-inch center section.
- (3) 1-inch diameter Curb Boxes:
  1. Bingham and Taylor 94 F.
- (4) 1½-inch and 2-inch diameter Curb Boxes:
  1. Tyler or Bingham and Taylor (Standard Valve Box).
  2. No rods or rings.
  3. See valve box material requirements of Article 704 – ‘Furnish & Install Water Valve’

**702.6 Disinfection Chemicals.**

- (1) Dry chemicals:
  1. Chloride of Lime.
  2. HTH.
  3. Pittchlor.
  4. Or equal (65 % available Chlorine), granular form only.
- (2) Liquid:

Part VII - Water Mains and Service Laterals

1. Only to be used with Engineer's written authorization.
2. Sodium hypochloride.

## **ARTICLE 703 - CONSTRUCTION METHODS**

---

### **703.1 General.**

- (1) Construct water main and appurtenances in accordance with AWWA C600 - latest revision except when otherwise required in these Specifications.
- (2) In case of discrepancy between these Specifications and the approved drawings and/or Contract Documents, conform to the hierarchy as described in Article 104.
- (3) All existing and new water valves are to remain visible and accessible at all times.
- (4) Valves and hydrants may only be operated in the presence of, and with the authorization of the Engineer.
- (5) Work done in the vicinity of any tree located in **City property or public right-of-way** is to be done in accordance with Article 107 of these Specifications.
- (6) Conform to the requirements of Article 203 of these Specifications for all existing pipes, structures, attached parts, and connections that are approved by the Engineer to be removed.
- (7) Utility trench patches are to be done in accordance with the requirements of Article 502 of these Specifications and the Standard Detail Drawings.
- (8) Utility line openings, as required in the Contract Documents or as ordered by the Engineer, are to be done in accordance with Article 508 of these Specifications.

### **703.2 Installation Tolerance.**

- (1) Do not install new water main and appurtenances without field-staked line and grade. Install water main and appurtenances to the line and grade depicted on the approved drawings.
- (2) Allowable installation tolerance:
  1. Horizontal: 0.1 feet.
  2. Vertical: 0.1 feet.
- (3) Work performed without line and grade, beyond the allowable installation tolerance, or Extra Work performed without authority, will be considered unauthorized and may not be measured or paid. The Violation consequences for unauthorized work are subject to Article 105 and Article 703 – ‘Repairs and Alterations’.
- (4) The lines, grades, locations, and dimensions shown on the plans are subject to adjustment by the Engineer during construction per Article 105. It shall be understood that the elevations for water mains as shown on the drawings are subject to revisions to accommodate field conditions as necessary. The Engineer reserves the right to adjust profile grades within 2-feet of the elevations shown on the approved drawings without adjustment in compensation.
- (5) Before installing any proposed variance from the approved drawings, obtain authorization in writing from the Engineer per Article 703 - ‘Repairs and Alterations’ and Article 105 of these Specifications.

### **703.3 Repairs and Alterations:**

(1) This section covers:

1. Emergency repairs of the water system.
2. Proposed alterations of the water system.
3. Unauthorized tampering of the water system.
4. Proposed deviations from the approved water main construction drawings or Contract Documents.

#### **703.3.2 Requirements:**

- (1) Per Madison General Ordinance Section 13.205, make no unauthorized alterations to the water system. Only when properly authorized to proceed may any work on the water system occur.
- (2) When authorized, this work is subject to but not limited to the following requirements:
  1. Perform all work in accordance with these Specifications.
  2. Safeguard and protect all Madison Water Utility facilities at all times.
  3. Do not operate valves or hydrants without direction from the Water Utility Inspector.
  4. Provide proper water shut-off notification to affected customers in accordance with these Specifications.
  5. Perform all field-cuts with an approved mechanical pipe cutter or power saw. All field-cuts shall be made straight, true, and without damaging the pipe.
  6. Concrete encasement pipe repairs are not permitted. Concrete encasement for other purposes, such as a concrete collar, requires written approval from the Engineer.
  7. Perform a complete clean-up of the work area and completely restore all disturbed surfaces to original condition, or better.

#### **703.3.3 Notice and Approval of Work:**

- (1) For anticipated repair work, including the raising or facing of hydrants, notify the Engineer a minimum of 2-working days prior to the proposed beginning of such work.
- (2) To propose an alteration of the existing system or a deviation from the approved water main construction plan or Contract Documents, submit the request in writing a minimum of 3-working days prior to when work will be needed. The variance request shall include a sketch that effectively depicts the proposed revision. The Engineer will review the request and respond within 3-working days.
- (3) Emergency repairs or planned work may be authorized by the Engineer with less notice or verbal approval at their discretion.

**703.3.4 Violation Consequences:**

- (1) Be subject to a forfeiture per Madison General Ordinance Section 13.205 for each day or partial day of violation.
- (2) Unauthorized work may not be paid for by the City and may be ordered to be removed or replaced at the Contractor's expense as specified in Article 105.
- (3) Risk loss of prequalification status with the City of Madison.
- (4) Be liable for all damages, claims, lawsuits, and/or other associated costs including Water Utility costs for labor, equipment and materials.

**703.1 Excavation.**

- (1) Construct water mains and appurtenances in open trenches and in a manner to protect the pipe and appurtenances from unusual stresses at all times.
- (2) When permitted by the Engineer in writing, water mains may be installed by tunneling and/or jacking methods in lieu of open trenching. Prepare and submit to the Engineer in writing, the details of construction including a bore pit plan and according to Article 703 – 'Repairs and Alterations'.

**703.1.1 Trench Excavation:**

- (1) All excavation, sheeting, shoring and bracing shall be done in accordance with the latest edition OSHA regulations and any additional requirements specified in the Plans or Contract Documents.
- (2) Provide all sheeting, bracing and/or shoring necessary to protect the work, existing property, utilities, pavement, etc., and to provide safe working conditions in the trench. All costs of sheeting, bracing and/or shoring is considered incidental to any work which necessitates it.
- (3) When not in use, remove sheeting and bracing, unless permission to leave in-place has been given in writing by the Engineer.
- (4) Excavate trenches in conformity with the required alignment and grades as shown on the drawings and as laid out in the field by the Engineer.
- (5) Remove all vegetation and topsoil along the trench line to the width of the proposed trench before beginning excavation.
- (6) Deposit material excavated from the trench on the sides of the trenches and excavations, beyond the reach of slides. Transport material to spoil banks as an alternative.
- (7) Properly dispose of surplus material at no additional cost to the City. Surplus material includes but is not necessarily limited to:
  1. Vegetation from the trench line.
  2. Excavated rock or cobbles in excess of 6-inches in diameter.
  3. Boulders (per Article 704).



4. All other material from excavation not needed or suitable for backfilling trenches.
- (8) For water main construction, the width of the trench shall be such as to leave a clear space of not less than 6-inches nor more than 1-foot between the earth wall, or the supporting sheeting or bracing where such is used, and the sides of the pipe. The trench width established by this pipe clearance, measured at the spring line, shall be applicable to that portion of the trench from 1-foot above the top of the pipe to the bottom of the trench.
- (9) On streets opened to traffic, on restricted easements, and other specified locations, the width of the trench at the ground surface is limited to the outside diameter of the pipe plus 2-feet, plus the amount necessary for sheeting or bracing.
- (10) The Engineer reserves the right to limit the extent of excavation depending on the nature of the soil and other conditions.
- (11) As ordered by the Engineer due to trees, fences, buildings, shrubs, etc., dig trenches by hand.

**703.1.2 Excavation in Poor Soils:**

- (1) If, in the opinion of the Engineer, an artificial foundation is necessary because of the nature of the excavated material, excavate the unsuitable material and replace with suitable specified material to produce an acceptable pipe foundation.
- (2) The undercut depth shall be as directed by the Engineer but shall be a minimum of 1-foot below the bottom of the pipe. Any work involved in forming a satisfactory foundation at depths of 1-foot or less below the bottom of pipe will be considered to be incidental to the work.
- (3) Backfill this portion of the trench with specified approved bedding material and mechanically compact the select fill prior to laying the pipe. Limit the width of the trench excavation to the outside diameter of the pipe plus 2-feet, plus the amount necessary for sheeting and/or bracing.
- (4) Excavation beyond the allowable 1-foot shall be considered undercut and will be paid as specified for undercut.

**703.1.3 Dewatering:**

- (1) In accordance with Part V of these Specifications, remove by pumping, bailing, or otherwise, any water that may accumulate or be found in the trenches and other excavations.
- (2) Form all dams, flumes or other works necessary to keep the trenches or excavations entirely clear of water while the water mains and their appurtenances are being installed.
- (3) Direct all water from excavations, so as not to flow over or damage private or public property.
- (4) All costs of dewatering are considered to be incidental to the associated work.

**703.2 Temporary Support.**

- (1) Under no circumstances shall new water main pipe be used to support any underground facilities, structures or any other objects. If new water main pipe is used for support, the pipe will be rejected, tagged by the City as rejected pipe, and will be immediately removed from the job site. The rejected pipe shall not be used on any other City projects.

- (2) Construction of pipe supports and utility line supports shall conform to the latest edition OSHA regulations and the requirements of Article 508 of these Specifications.

### **703.2.1 Temporary Water Main Support:**

- (1) Temporarily support water mains whenever 12 or more lineal-feet of main is exposed for a period of 48-hours or longer. Exposure may be perpendicular, parallel or at any angle to an opening or trench.
- (2) Submit a support plan designed and stamped by a State of Wisconsin Licensed Professional Engineer to the Engineer a minimum of 2 working days before the exposure is anticipated to occur.
- (3) The Engineer reserves the right to require immediate temporary support of any exposed pipe in the case of a justifiable concern for the integrity of the pipe, worksite or public safety.
- (4) The Engineer reserves the right to pressure test or re-test any pipe which has been subjected to temporary support. In the event of a failed test, correct any defects until the pipe passes pressure testing at no additional cost to the City.

### **703.3 Backfilling.**

#### **703.3.1 Backfill Requirements:**

- (1) Backfill trenches and excavations immediately after the water main and appurtenances have been installed.
- (2) Close trenches at the end of every day.
- (3) Backfill to the original surface elevation or otherwise specified elevation. In the event of a shortage of material to perform this work, including replacement as may be required by rock excavation or removal of boulders, provide the necessary fill material at no cost to the City.
- (4) Except as may be necessary in compacting and backfilling, do not walk or work on installed pipe until the trench has been backfilled to an elevation at least 2-feet above the top of the pipe. Do not take backfill material from trench walls below an elevation 2-feet above the top of pipe.
- (5) Evenly place backfill material so that no unbalanced pressures are placed upon the water system. Backfill material may be dumped directly into the trench from trucks when the amount of material to be dumped is controlled by proper equipment.
- (6) Deposit, spread and level backfill material in layers not exceeding 12-inches in thickness before compacting. Compact each layer to the density specified herein before placing the succeeding layer. When the material being compacted is of a granular nature and the compacting equipment is adaptable for the purpose, the thickness of the layer may be increased to a maximum of 24-inches at the Engineer's discretion, provided the required compaction density is obtained.
- (7) Only use heavy equipment in the trench for compaction or other purposes if the pipe is adequately protected and the Engineer approves. Trucks, vehicles, or other equipment are not allowed within the limits of the trench prior to the completion of the backfilling operations.

## Part VII - Water Mains and Service Laterals

- (8) Dump imported backfill material along the top of the trench beyond the reach of slides. Do not store imported material such that it increases the stresses on the trench section.
- (9) Carefully draw and remove any required sheathing and bracing such that it will not disturb the completed work. Carefully fill and compact any voids created by the removal of sheathing and bracing with approved backfill material.
- (10) Backfilling of structures shall be done in accordance with Article 301 – ‘Protection of the Concrete’.
- (11) Whenever possible, backfill trenches and other excavations with materials excavated during the course of the work.
- (12) Do not include vegetation, stones, or fragments of broken rock in excess of 6-inches in any dimension in the backfill.
- (13) Note that the Engineer may reject material due to:
  1. Unacceptable moisture content.
  2. Unacceptable gradation or composition
  3. The presence of frozen material.
  4. Remove all rejected materials from the site.

### **703.3.2 Compaction Requirements:**

- (1) Mechanically compact backfill layers in trenches and excavations to thoroughly consolidate the material to the density specified and to not damage or disturb the pipe or other structures.
- (2) Begin mechanical compaction of the backfill material when the depth of the backfill material is 2-feet above the top of the pipe. (In the case of structures, begin compaction of the backfill material with the placing of the first layer of backfill material).
- (3) The Engineer will perform compaction testing as necessary to verify uniformity of compaction.
- (4) Compaction Density Requirements:
  1. From 2-feet over the pipe to within 3-feet of the bottom of subgrade:

A minimum of 90% of maximum density.
  2. Within 3-feet of the bottom of subgrade:

A minimum of 95% of maximum density.
- (5) Determine maximum density in accordance with the Standard Method of Test for the Moisture-Density Relations of Soils, ASTM Designation: D 1557, Method D, latest revision. Replace the fraction of material retained on a  $\frac{3}{4}$ -inch sieve, with No. 4 to  $\frac{3}{4}$ -inch material.
- (6) Determine the density of compacted backfill in accordance with one of the following: Test for Density of Soil-in-Place by the Sand-Cone Method, ASTM Designation: D 1556, latest revision,

or Test for Density of Soil and Soil-Aggregate in Place by Nuclear Methods, ASTM Designation: D 2922, latest revision.

- (7) In the event that the material in the density sample differs in percentage of aggregate retained on a No. 4 sieve from that in the sample upon which maximum density was determined, adjust the maximum density in accordance with approved procedures.
- (8) In the event of inadequate moisture in the backfill materials, add water as necessary to obtain the required compaction.
- (9) Whenever the work of installing water pipes takes place during freezing weather, follow the specifications for trench compaction above, if practicable. If the specified compaction cannot be achieved, and the Engineer determines that the work may not be suspended until more favorable weather conditions exist, proceed as follows:
  1. Remove all frozen material in the trench at the beginning of the day's work.
  2. Do not compact frozen materials.
  3. Compact material in 6-inch maximum lifts.
  4. Compact to densities specified herein.
- (10) If the top 3-feet of material does not meet 95% of maximum density, remove the material and place Select Fill using 6-inch maximum lifts and compact to 95% of maximum density.
- (11) As a guideline, no construction will be permitted when the temperatures are too cold to achieve the specified compaction of the backfill. Ensure that temperatures are at least 15°F and rising, with winds less than 10 mph, before considering working in freezing conditions.

### **703.3.3 Embankments:**

- (1) Where the grade of the water main is such that the top surface of the pipe requires protection, construct an embankment over the pipe.
  1. Embankment height:

Specified by the Engineer and adequate to provide proper protection.
  2. Embankment width:

Minimum of 2-feet wider than the external diameter of the pipe at the top.
- (2) Embankment side slopes:
- (3) A ratio of not less than 2-feet horizontal to 1-foot vertical from the top of the embankment to the existing ground surface.
- (4) Use surplus acceptable excavated material or, if required, furnish other approved material for embankment construction. Placing and constructing the embankment over the pipe is incidental.
- (5) If imported material is required by the Engineer to complete the embankment over the pipe, only the authorized imported fill quantities will be paid for as provided herein.

- (6) Compact embankment material as required in Article 202 – ‘Standard Compaction’.

### **703.4 Connecting to Existing Water Mains.**

- (1) There are three types of connections to existing mains:
  1. A plug-removal connection is a connection that requires the removal of a slip or mechanical joint plug from an existing fitting or the end of a water main. Perform all work associated with the plug removal connection per Article 704 - ‘Cut-In or Connect-To Existing Water System’.
  2. A cut-in connection is a connection that requires the installation of a new fitting or valve in an existing water main. Perform all work associated with the cut-in connection per Article 704 - ‘Cut-In or Connect-To Existing Water System’. Cut-in connections to HDPE water mains shall also be constructed in accordance with Article 704 - ‘Horizontal Directional Drill Pipe’.
  3. A live-tap is a connection in which the main is tapped under pressure and in-service while a tapping valve is installed by the City. Furnish the ditch as necessary for the City to make the tap and perform the associated cut-off and cap of the existing water main per Article 704 ‘Furnish Excavation and Ditch for Live Tap’. Isolate and depressurize all live-tap connections on any PVC, HDPE and CIPP-lined water mains prior to providing the ditch to the City.

### **703.5 Water Main Shutoffs.**

- (1) Do not interrupt water service without prior notification to all affected residents and property owners.
- (2) In the case of an emergency or an unplanned shut-off, notify all affected residents and property owners during or immediately after the water is turned off.
- (3) Minimum requirements for all planned shut-offs:
  1. Provide 2 working days notice to affected water users.
  2. The shut-off may not begin earlier than 8:00 AM.
  3. The shut-off may not exceed 8-hours.
- (4) In the event a planned shut-off is anticipated to require more than 8-hours, re-notify all affected water users prior to the expiration of the time limit listed on the original notification.
- (5) Perform all shut-offs as proposed in the Contract Documents. The proposed shut-offs are provided for reference purposes to aide planning connection point isolation and preparing water user notification lists for planned outages. Propose any alternative connection methods which differ from the proposed shut-off in accordance with Article 703 – ‘Repairs and Alterations’.
- (6) Obtain prior authorization from the Engineer and be responsible for all valve turnings. Be properly equipped at all times for doing such work.

### **703.6 Mechanical Joint Pipe and Fittings.**

- (1) A mechanical pipe joint is made by compressing a rubber gasket between a bell, cast on the end of one pipe, and a gland that slides along the plain end of the pipe to be joined. The joints are tightened using nuts and bolts.
- (2) Assemble mechanical joints in accordance with AWWA C600 – latest revision.
- (3) Restrained joints using MEGALUG® Series 1100 or equal mechanical joint-restraint retainer glands shall have bolts tightened in accordance with the manufacturer’s installation specifications.
- (4) Before slipping the gland and the gasket onto the plain end for joint assembly, lubricate both the gasket and the plain end of the pipe with an approved pipe lubricant meeting the requirements of ANSI/AWWA C111/A21.11 - latest revision.
- (5) Place the gland on the plain end with the lip extension toward the joint, followed by the gasket with the narrow edge toward the joint. Insert the pipe into the bell and press the gasket firmly and evenly into the gasket recess in the bell keeping the joint straight during assembly. Push the gland toward the bell and center it around the pipe, with the flange lip against the gasket. Insert bolts and hand tighten nuts. Deflect pipe after assembly, but before tightening bolts.

### **703.7 Thrust Restraint.**

- (1) Provide thrust restraint for all fittings by one of two methods:

1. A combination of concrete thrust blocking and mechanical joint restraint.
2. A combination of push-on joint and mechanical joint restraint.

- (2) Regardless of the restraint method employed, restrain all mechanical joints using MEGALUG® Series 1100 or equal retainer glands installed per the manufacturer recommendations and include concrete blocking at all hydrant installations per Standard Detail Drawing 7.03(A).

#### **703.7.1 Concrete Thrust Blocking:**

- (1) Where concrete blocking serves as the thrust restraint method, block all hydrants and fittings, except vertical down bends, per the required bearing area in the table below and Standard Detail Drawing 7.03(A). Block vertical down bends per Detail 7.03(B). Restrain per Detail 7.03(C) only where specified or approved by the Engineer.

<b>Required Undisturbed Bearing Area of Concrete Thrust Blocking (Square Feet)</b>					
<b>Fitting Size(In)</b>	<b>Tee, Wye, Hydrant, Plug or Cap</b>	<b>90° Horizontal Bend, Plugged Cross or Tee (Plugged on Run)</b>	<b>45° Horizontal Bend</b>	<b>22-1/2° Horizontal Bend</b>	<b>11-1/4° Horizontal Bend</b>
4	0.9	1.3	0.7	0.4	0.2
6	2.1	3.0	1.6	0.8	0.4
8	3.8	5.3	2.9	1.5	0.4
10	5.9	8.3	4.5	2.3	1.2
12	8.5	12.0	6.5	3.4	1.8
16	15.1	21.3	11.5	6.0	3.2
20	23.6	33.3	18.0	9.4	4.9
24	33.9	48.0	26.0	13.5	7.1
30	53.0	75.0	40.6	21.1	11.1

Note: Listed areas are based on a test pressure of 150 psi and an allowable soil bearing pressure of 3,000 pounds per square foot. To compute bearing areas for different test pressure, use the following equation: Bearing area = (Test Pressure ÷ 150) x (Table Value)

- (2) On hydrants and fittings requiring less than 4-square feet bearing area use either cast-in place concrete or solid concrete blocks placed between the appurtenance and the undisturbed wall of the trench. Fill all voids with compacted clear stone or screenings.
- (3) For fittings requiring 4-square feet bearing area or greater, use only cast-in-place concrete meeting the requirements of Article 301 of these Specifications and a minimum strength of 3,000 psi at 7-days. Protect the concrete from freezing for a minimum of 24-hours after placement.
- (4) Do not perform pressure testing within 72-hours of pouring the thrust block. A 9-bag concrete mix may be authorized by the Engineer upon request.
- (5) Do not extend the concrete blocking beyond the joint. Protect all nuts and bolts from the concrete during pouring so they can be removed without damaging the thrust block.
- (6) Do not backfill over thrust restraint blocking until it has been inspected by the Engineer. If backfilling takes place prior to the inspection of the blocking, the Engineer may require the blocking to be re-exposed for inspection at no additional cost to the City.

**703.7.2 Joint Restraint:**

- (1) Where joint restraint serves as the thrust restraint method, with the exception of vertical bends, restrain all push-on joints within the lengths specified in the ‘Required Joint Restraint Distance from Fitting’ table below. Restrain vertical bends per Standard Detail Drawing 7.10.
- (2) Restrain push-on joints with the pipe manufacturer’s approved joint restraint locking gasket per Article 702.
- (3) Restrain all mechanical joints per Article 702 and Article 703 – ‘Mechanical Joint Pipe and Fittings’.

REQUIRED JOINT RESTRAINT DISTANCE FROM FITTING (FEET)								
FITTING TYPE	4-IN	6-IN	8-IN	10-IN	12-IN	16-IN	20-IN	24-IN
TEE: RUN OR CROSS: PLUGGED	10	10	10	10	10	20	20	20
TEE: BRANCH	10	10	10	10	10	10	10	10
CAP/PLUG ON DEAD END	30	45	60	70	80	110	140	160
90° HORIZONTAL BEND	10	15	20	25	25	30	40	50
45° HORIZONTAL BEND	5	10	10	10	15	15	20	25
22-1/2° HORIZONTAL BEND	5	5	5	5	10	10	10	15
11-1/4° HORIZONTAL BEND	3	3	3	3	5	5	5	5
REDUCER: SIZE X 4"	-	25	45	60	75	100	130	150
REDUCER: SIZE X 6"	-	-	25	45	60	90	120	145
REDUCER: SIZE X 8"	-	-	-	25	45	80	110	135
REDUCER: SIZE X 10"	-	-	-	-	25	65	100	125
REDUCER: SIZE X 12"	-	-	-	-	-	50	85	115
REDUCER: SIZE X 16"	-	-	-	-	-	-	50	90
REDUCER: SIZE X 20"	-	-	-	-	-	-	-	50
HYDRANT	RESTRAIN ALL JOINTS ON HYDRANT LEAD							
NOTES:								
SOIL TYPE = GM (SILTY GRAVELS & GRAVEL/SILT/SAND MIXES)					DEPTH OF BURY=6 FT			
SAFETY FACTOR=1.5			TRENCH TYPE =4		TEST PRESSURE=150 PSI			

**703.7.3 Alternate Restraint Methods:**

(1) For locations where the Engineer determines one of the two approved restraint methods will not provide adequate thrust restraint or is impractical, the Engineer may require an alternate means of restraint. Alternate thrust restraint methods include those shown in Standard Detail Drawings 7.02 and 7.03(C). Alternate thrust restraint methods are to be used only when specifically authorized.

(2) Requirements:

1. Where pipe is used for an anchor, provide a sufficient length to fully restrain the fitting.
2. When using threaded rod for restraint use ¾-inch 304 stainless steel threaded rod with stainless steel nuts and washers.

(3) The contractor may propose alternate restraint methods in accordance to Article 703 – ‘Repairs and Alterations’.

**703.8 Polyethylene Encasement.**

- (1) Encase all ductile iron pipe, joints, and fittings in polyethylene wrap installed per the requirements of the American National Standard for Polyethylene Encasement for Ductile Iron Pipe Systems (ANSI/AWWA C105 - latest revision) and the manufacturer’s requirements. All cuts and repairs to the polyethylene wrap shall be in accordance with ANSI/AWWA C105 and the manufacturer’s requirements.
- (2) Install polyethylene encasement with a minimum overlap of 1-foot at all joints. Tape the polyethylene wrap every 3-feet and at joints to prevent soil from coming into contact with the pipe.



- (3) Carefully place backfill material to prevent tears and punctures in the polyethylene encasement. Promptly repair any tears and punctures per the manufacturer's recommended procedures.
- (4) When connecting to or tapping into existing or new polyethylene encased pipe, repair or replace any polyethylene wrap which was cut away to allow for the connection or tap. Include the required overlap and taping requirements as described herein.

### **703.9 Copper Service Laterals.**

- (1) Provide and install saddles on all 1-1/2-inch and 2-inch services and at all service lateral taps on new or existing PVC, HDPE, or CIPP-lined water mains. Use a standard valve box in lieu of a curb box, with no rod or rings required, for all 1-1/2-inch and 2-inch services.
- (2) Use a pipe cutter to cut all copper tubing. Hacksaws or other such devices to cut copper tubing are not permitted.
- (3) Excavate and expose the area on the water main for new service connections, as noted on the drawings or as otherwise instructed by the Engineer. Locate the tap on the upper half of the main at a 45° angle from the vertical plane, perpendicular to the water main and on the side of the main to which the service extends.
- (4) Tap the water main and install the corporation stop using a tapping machine specifically designed to tap water main under pressure. No other method of tapping the water main will be allowed. Repair and replace any cut or removed polyethylene encasement following the tap to ensure that the water main is fully protected.
- (5) After the tap has been made and the corporation stop and bend have been inserted, loop the copper tubing out and then back toward the main, then back away from the main to form the shape of a vertical "S". Ensure that the "S" loop is of sufficient size so that it uses a minimum of 2-feet of copper tubing. Ensure that the highest portion of the loop is not higher than the top of the water main.
- (6) Lay the service flat to the property line or otherwise indicated point of termination. Provide a minimum of 6-feet of cover below finished grade.
- (7) Place at least 1-foot of approved bedding material around the copper service pipe. The bedding material is considered incidental to the cost of backfilling the service lateral trenches. Protect all laterals and appurtenances from damage when backfilling. Stones 3-inches in diameter or larger are not allowed within 18-inches of the copper service. Backfill containing rocks 3-inches or larger may not be placed around curb boxes.
- (8) Restore any disturbed terrace or turf areas associated with the lateral installation work. Any terrace or turf restoration work is considered incidental to any work associated with service laterals.
- (9) Coordinate with property owners to allow for flushing service laterals both prior to and immediately after any work impacting a service. Resolve any problems with property owners, including but not limited to problems regarding discolored water or low/no water flow.
- (10) Repair any damage to new or existing service laterals, curb stops or curb boxes resulting from adjacent excavations located within 5-feet of the water lateral at no cost to the City.

**703.10 Disinfection.**

- (1) Conform disinfection of materials, procedures and requirements to AWWA C651 – Standard for Disinfecting Water Mains - latest revision, except as otherwise required herein.
- (2) Prevent dirt, mud, muddy water, or other foreign matter from entering the pipe or fittings during installation.
- (3) Furnish and install a watertight plug for all open ends of pipe and fittings whenever work is temporarily stopped, including during work breaks or overnight. Failure to properly plug and protect the pipe during construction may result in additional costs to for all work and materials necessary for cleaning pipes and fittings contaminated during construction.
- (4) Deposit the following amounts of Calcium Hypochlorite (HTH or approved equal - 65% available chlorine by weight) in each 20-foot length of pipe:

Pipe Diameter (inches)	Amount of HTH or approved equal required (ounces)
4	1
6	2
8	3-1/2
10	5-1/2
12	7
16	14

- (5) The Engineer reserves the right to require any pipe or fittings to be swabbed cleaned prior to lowering into the trench. When swabbing is required, disinfect the subject material by swabbing or soaking thoroughly with a 10:1 (water:bleach) solution.

**703.11 Flushing.**

- (1) Flush out the highly-chlorinated disinfection water after meeting the required contact time. The City will execute the water main flushing. Provide labor to assist the Engineer with valve turning for the duration of the flushing operation.
- (2) The discharge volume is estimated to be three times the volume of water contained in the section of main to be flushed. Estimates in CCF (100 cubic feet) calculated as:

Part VII - Water Mains and Service Laterals

$$V = 3 * \left[ \frac{(3.14) * D^2 * L}{400} \right]$$

Where:

*V = Flush Volume in CCF*

*D = Pipe Diameter in Feet (see below)*

*L = Pipe Length in Feet*

<u>D(in)</u>	=	<u>D(ft)</u>
6		0.50
8		0.67
10		0.83
12		1.00
14		1.16
16		1.33
18		1.50
20		1.67
22		1.83
24		2.00

- (3) Discharge to the stormwater sewer system whenever possible. Discharge to the sanitary sewer system may be permitted only when no other option exists.
- (4) Discharge to Storm Sewer System:
  1. Inform the Engineer, in writing, of the intent and means to flush water main to the storm sewer a minimum of 2-working days prior to the proposed scheduled flush.
  2. Note that the Engineer will schedule the next available flushing crew to perform the flush.
  3. Note that all discharge to the storm sewer will be de-chlorinated by the Engineer.
- (5) Discharge to Sanitary Sewer System:
  1. Inform the Engineer, in writing, of the intent and means to discharge flushing water to the sanitary sewer system.
  2. Verify with the Engineer that other discharge options are unavailable.
  3. With the consent of the Engineer, obtain a permit for approval to discharge flushing water to the sanitary sewer system from the City of Madison Engineering Department.
  4. The Engineer will schedule flushing operations no sooner than **2 working days** from the time the permit is requested (the timeframe for permit approval is 2 working days).
  5. Obtain permit approval in advance of flushing operations.
  6. The Water Utility will pay all costs associated with the sanitary sewer discharge permit.

## Part VII - Water Mains and Service Laterals

- (6) To obtain a sanitary discharge permit, call City Engineering at (608) 267-1995 and provide the following information:
  1. Contractor contact information.
  2. Requested time and date of discharge.
  3. Diameter and length of the water main to be flushed.
  4. Estimated discharge volume.
  5. Location of the proposed sanitary access structure.
- (7) Do not exceed the permit-approved flushing rate.
- (8) Do not flush to any location other than the permit-approved sanitary access structure.
- (9) Proceed with flushing until the Engineer deems the flushed sections of water main to be adequately de-chlorinated.
- (10) In cases where, for example, a downstream lift station is located, the Engineer may require a vac-truck be provided at no additional cost to ensure that the station is not overwhelmed by discharge.
- (11) Vac-truck assistance and all other on-site assistance (outside of the standard flushing operations) provided by the Engineer, City of Madison Engineering Department, or Madison Metropolitan Sewer District will be billed on a time and material basis.
- (12) In the event that the permit limit on discharge rate to the sanitary sewer is such that using the sanitary sewer would require extensive time, or the flushing operation would be determined to be ineffective, the Engineer may require an alternative flushing plan at no additional cost to the City.

### **703.12 Testing.**

- (1) Newly installed water mains shall undergo water quality testing and hydrostatic pressure testing prior to final acceptance by the City. The mains may also be tested for electrical conductivity through the joints. Repairs or replacement of any defective work is to be done at no additional cost to the City.

#### **703.12.1 Conductivity Testing:**

- (1) Complete all backfilling and obtain approval of the hydrostatic pressure tests prior to performing conductivity testing. The Engineer is to be witness and verify all conductivity testing procedures, test section lengths, and results.
- (2) Testing of the first section of pipe installed may be required by the Engineer to demonstrate that the pipe is being installed in an acceptable manner.
- (3) Furnish approved testing equipment. Perform test while the newly installed main is at normal operating pressure with all air expelled.
- (4) Repair or replace any defective areas noted during the conductivity testing to the satisfaction of the Engineer. Any required repairs or replacement shall be done at no cost to the City.

## Part VII - Water Mains and Service Laterals

- (5) When the connection to the existing system is not made with a valve, test on the existing section of main to the first available valve(s) to determine the condition of the system. Alternatively, provisions may be made to test the work separately (prior to connection to the existing system), with the Engineer's approval.
- (6) Make connections for the test at fire hydrants or valves:
- (7) Hydrant connection requirements:
  1. In the open position with the caps on during the test.
  2. Clamp the cable to the hydrant standpipe and flange bolt.
  3. Do not use the hydrant-operating nut as a terminal during the test.
- (8) Where hydrants or valves are not available, connections will be made to straps welded directly to the pipe.
- (9) Use a length of insulated wire that can reach from one connection to the other (the "external circuit"). Testing the external circuit may be conducted two ways.
- (10) Method One:
  1. Measure the resistance of the external circuit with an ohm-meter and record this number prior to testing the pipe length.
  2. Hook the external circuit wire to the new main as previously described and take a new measurement with the same ohmmeter.
  3. In an electrically continuous length of main, the total resistance measured should be just slightly more than that of the external circuit – generally no more than 2-3 ohms. Instances of the measured total resistance measured being significantly greater, equate to evidence of defective electrical contact in the pipe.
  4. Isolate and correct defective segments, if required. Re-test until the requirements are met.
- (11) Method Two:
  1. Display conductivity by the reactivity of "tester" devices, such as a low-wattage light bulb with a battery. Any such equipment will be subject to approval of the Engineer.
  2. Hook the external circuit wire to the new main as previously described and connect the external circuit to the tester.
  3. Instances of non-reactivity in the tester equate to evidence of defective electrical contact in the pipe.
  4. Isolate and correct defective segments, if required. Re-test until the requirements are met.

### **703.12.2 Water Quality Testing:**

- (1) Perform water quality testing procedures to AWWA C651 – Standard for Disinfecting Water Mains - latest revision, except as otherwise required herein.

## Part VII - Water Mains and Service Laterals

- (2) Test water main after a section has been installed and the trench is backfilled. Test sections are not to exceed 1,200-feet in length. A separate test is to be performed for each branch of main.
- (3) Assist the Engineer in slowly filling the new main from an uncontaminated source by operating the necessary valves. DO NOT operate any valves under any circumstances, except as directly instructed to do so, by and in the presence of the Engineer.
- (4) Loosen one nozzle cap per hydrant to allow air pockets to dissipate along the full length of the pipe segment being filled.
- (5) Hold the chlorinated water in the newly installed main for a minimum of 48-hours. Upon commencement of the 48-hour period, schedule flushing and sampling activities with the Engineer.
- (6) The Engineer will collect and submit samples for bacteriological testing. The newly installed system will not be put into service until the Engineer receives a safe bacteriological sample result from the certified lab.
- (7) If a sample receives an unsafe test result, schedule with the Engineer to have the main flushed and sampled two additional times, occurring at least 24-hours apart.
- (8) If either of the two follow-up samples collected do not pass the test, disinfect the main again per AWWA C651 and the chlorinated water again held in the pipe for a minimum of 48-hours.
- (9) Following the 48-hour holding period, assist the Engineer with flushing the line again and re-sampling.
- (10) Repeat this process, at no additional cost to the City, until a safe sample is received from the City's designated testing lab. Cover all costs incurred by the Engineer, including any labor and material.

### 703.12.3 Hydrostatic Pressure Testing.

- (1) Hydrostatically pressure test all new water main, including hydrants, in accordance with the AWWA Standard for Installation of Ductile Iron Water Main (AWWA C600 - latest revision).
- (2) After the main has been declared bacteriologically safe by the designated testing lab, and following the installation of service laterals on new private development work, or as soon thereafter convenient for the Engineer, conduct a hydrostatic pressure test. On street reconstruction projects, pressure test mains prior to making any water service lateral connections. All pressure tests shall be witnessed and verified by the Engineer.
- (3) Expel all air from the pipe prior to the engineer's arrival to witness the start of the pressure test. If hydrants or blow-offs are not available at high points, make the necessary taps at high points to expel the air and insert plugs after the air is expelled.
- (4) Hydrostatic Pressure Test Requirements:
  1. 150 psi test pressure (minimum).
  2. Minimum duration of 2-hours.
  3. Test pressure may not drop below 125 psi at any point during the pressure test.

- (5) The Engineer reserves the right to install a locking mechanism at the test gage or install direct-connect pressure recorders for the test.
- (6) Higher pressures and shorter durations may be considered upon request.
- (7) Use only clean, disinfected containers and equipment to add make-up water at the end of the pressure testing. The Engineer reserves the right to require make-up water be added at any point during the pressure test if the test pressure drops more than 5 psi during the test. Furnish all equipment, labor, and supplies necessary to apply pressure to the pipeline in a manner satisfactory to the Engineer.
- (8) The testing allowance (allowable makeup water) shall be no greater than as calculated in the formula:

$$L = \frac{SD\sqrt{P}}{133,200}$$

L = Gallons per hour

S = Length of test main in feet

D = Diameter of pipe in inches

P = Average pressure in pounds per square inch during testing

- (9) When testing against closed metal-seated valves, an additional testing allowance per closed valve of 0.0078 gal per inch of nominal valve size is permitted.
- (10) If the pipe line fails the pressure test, locate the leak and repair it to like-new condition. The proposed repair method is to be reviewed by the Engineer and result in an end product that is equal to, or better than new construction.
- (11) Following location and repair of the leak, repeat the pressure test until a satisfactory result is obtained. All costs associated with retesting the pipe line is considered to be incidental.

### **703.13 Finishing Work and Maintenance.**

- (1) Repair any structures or other features damaged during construction, including but not limited to:
  1. Concrete, asphalt, and gravel pavements.
  2. Stone flagging or paving.
  3. Sidewalks, curbs and gutters.
  4. Culverts.
  5. Fences.
- (2) Rebuild or re-lay all surfaces properly to the original line and grade in accordance these Specifications, or in the absence of applicable specifications, to original condition.
- (3) Prior to final acceptance by the Engineer, clean and grade the project area. Final payment will be withheld until such work is completed in a manner satisfactory to the Engineer

- (4) Maintain all repaired, restored, or replaced surfaces until final acceptance of the project by the City.
- (5) Repair, restore or replace all failures occurring during the guarantee period at no cost to the City.

### **703.14 Final Inspection.**

- (1) Final inspection will not be scheduled until:
  - (1) Repair, replace or adjust valve boxes, curb boxes and hydrants. The use of cheaters or other extensions to reach finished grade is not permitted.
  - (2) Repair or replace any other features disturbed or damaged by construction activities.
  - (3) All applicable finish work and maintenance is complete.
  - (4) All water system testing is satisfactorily completed.
- (2) When satisfied that all work is complete, notify the Engineer and schedule a walk through final inspection at least two working-days ahead of paving.
- (3) Complete the final inspection with the Engineer, reviewing all project records and paperwork for completeness.
- (4) Make the necessary repairs or corrections of any noted deficiencies, before final payment is made.

### **703.15 Water Utility Construction Services.**

- (1) Supplemental construction services provided by the Engineer include:
  1. Water main filling.
  2. Flushing.
  3. Testing.
  4. Live-tap installations.
- (2) Schedule services as follows:
  1. Between the hours of 7:00 AM and 3:00 PM.
  2. Monday through Friday.
- (3) Requests for supplemental construction services occurring outside of the approved hours will be subject to any associated overtime charges being billed.
- (4) Do not schedule live-tap installations to occur outside of the approved hours.
- (5) The Engineer reserves the right to decline any supplemental construction services which are requested to occur outside of the approved hours.



## **ARTICLE 704 – BID ITEMS, MEASUREMENT AND PAYMENT**

---

### **704.1 General.**

- (1) Visit the site prior to bidding and become familiar with the existing conditions. It will be the responsibility of the Contractor to work with the utilities located in the right of way to resolve conflicts during the construction process.
- (2) Prices for the various items include all means to complete the work as specified, such as (but not limited to):
  1. Equipment.
  2. Tools.
  3. Materials.
  4. Labor.
  5. Related incidentals.
- (3) The Water Utility will furnish tapping valves, tapping sleeves, and one valve box for all pressurized taps 4-inches or larger. With this one exception, the Water Utility will not furnish any materials to the Contractor unless specifically stated in the Contract documents.
- (4) Only work that is completed and accepted in accordance with the terms of these Specifications and the Contract Documents will be measured for payment.

### **704.2 Bid Items.**

- (1) Note that all requirements of Articles 701-704 and these Specifications, Standard Detail Drawings, and Contract Documents are applicable to all bid items as described or otherwise considered incidental. Include the costs of all required work in the unit prices that were bid in the Contract Documents, unless specifically noted otherwise.
- (2) This includes any sections of a bid item listed as “(Vacant)”.
- (3) In the event of conflicting information within these Specifications, the bid items govern.

### **704.3 Furnish & Install Pipe & Fittings.**

**4-Inch, Bid Item 70001; 6-Inch, Bid Item 70002; 8-Inch, Bid Item 70003; 10-Inch, Bid Item 70004; 12-Inch, Bid Item 70005; 16-Inch, Bid Item 70006; 20-Inch, Bid Item 70007; 24-Inch, Bid Item 70008.**

#### **704.3.1 Description:**

- (1) Furnish, install and test new water main and fittings. Work for this item also includes:
  1. Thrust restraints.
  2. Temporary flushing devices (blow-offs and/or temporary hydrants).
  3. Polyethylene encasement.
  4. Temporarily raising or lowering existing water services.
  5. Exposing existing water main to verify location and depth.
  6. Concrete and asphalt pavement removal.
  7. Restoring the site.

#### **704.3.2 Materials:**

- (1) Refer to Article 702 and this section.
- (2) All materials necessary to perform the work, including:
  1. Pipe and accessories.
  2. Fittings and accessories.
  3. Sleeves, clamps, tie rods, plugs.
  4. Thrust blocking and/or restrained-joint gaskets.
  5. Polyethylene encasement.
  6. Bedding material to cover the pipe.

#### **704.3.3 Construction:**

- (1) Refer to Article 703 and this section.
- (2) Pipe Laying and Bedding:
  1. Pipes with a minimum of 6-feet and a maximum of 7-feet of cover from final grade.
  2. For line or grade adjustments of 24-inches or less, use offsets in lieu of bend fittings.
  3. Inspect all pipe and fittings for damage and cleanliness prior to lowering into the trench. Any costs due to the repair of damaged valves and hydrants caused by sand or silt in the pipe will be assessed.

Part VII - Water Mains and Service Laterals

4. Never roll or push the pipe into the trench from the bank. Always lower the pipe into the trench using mechanical equipment.
5. Do not place chlorine in a pipe during installation that will not be filled and flushed within 45 days of installation.

(3) Slip Joints:

1. A slip joint is made by compressing a rubber gasket between a bell cast in the end of one pipe and the plain end of the pipe to be joined.
2. Assemble in accordance with AWWA C600 - latest revision, including:
3. Thoroughly clean the groove and the bell socket of the pipe or fitting, and the plain end of the mating pipe.
4. Using a clean gasket of the proper design for the joint to be assembled, make a small loop in the gasket and insert it in the socket, making sure the gasket faces the correct direction and that it is properly seated.
5. Apply lubricant to the gasket and plain end of the pipe in accordance with ANSI/AWWA C111/A21.11 - latest revision. Only use lubricant supplied by the pipe manufacturer.
6. Be sure that the plain end of the pipe is beveled, as square or sharp edges may damage or dislodge the gasket and cause a leak.
7. Push the plain end into the bell of the pipe, keeping the joint straight while pushing.
8. Deflect the pipe as required only after the joint is assembled.
9. Connect the bonding straps after the pipe is in place to ensure conductivity across the joint.

**704.3.4 Method of Measurement:**

- (1) Measured by length, in feet, to the nearest half foot for each size (diameter) of pipe installed.
- (2) Measured along the centerline of the pipe, from center to center of valves and fittings.
- (3) No deductions from the measured lengths for fitting installations.

**704.3.5 Basis of Payment:**

- (1) Paid at the contract unit prices under the following bid items:

<b>ITEM NUMBER</b>	<b>DESCRIPTION</b>	<b>UNIT</b>
70001	FURNISH AND INSTALL 4 INCH PIPE & FITTINGS	L.F.
70002	FURNISH AND INSTALL 6 INCH PIPE & FITTINGS	L.F.
70003	FURNISH AND INSTALL 8 INCH PIPE & FITTINGS	L.F.
70004	FURNISH AND INSTALL 10 INCH PIPE & FITTINGS	L.F.
70005	FURNISH AND INSTALL 12 INCH PIPE & FITTINGS	L.F.
70006	FURNISH AND INSTALL 16 INCH PIPE & FITTINGS	L.F.
70007	FURNISH AND INSTALL 20 INCH PIPE & FITTINGS	L.F.
70008	FURNISH AND INSTALL 24 INCH PIPE & FITTINGS	L.F.

Part VII - Water Mains and Service Laterals

- (2) Payment for temporary flushing hydrants and/or blow-offs will be considered only if subsequently required as a result of plan revisions issued by the Engineer:
  - 1. A payment of \$1,500.00 will be made for any authorized temporary flushing hydrant.
  - 2. Any hydrant used for temporary flushing purposes may not become a permanent fixture anywhere in the system.
  - 3. A payment of \$500.00 will be made for any 2-inch or larger blow-off device.
  - 4. Temporary hydrants or blow-offs resulting from a plan revision must be reviewed by the Engineer for payment considerations.
- (3) Additional Fittings, where authorized, are to be paid as follows:

<b>DESCRIPTION</b>	<b>UNIT</b>	<b>PRICE</b>
4-INCH FITTING	EACH	\$575.00
6-INCH FITTING	EACH	\$705.00
8-INCH FITTING	EACH	\$950.00
12-INCH FITTING	EACH	\$1,200.00
16-INCH FITTING	EACH	\$2,150.00
20-INCH FITTING	EACH	\$2,685.00

- (4) Total fitting quantity to be balanced out by any fittings identified on the plan set to be furnished and installed, but that were not furnished and installed.
- (5) Additional tee fittings:
  - 1. Paid or credited as 1½ fittings.
- (6) Additional offset and cross fittings:
  - 1. Paid or credited as 2 fittings.

#### **704.4 Horizontal Directional Drill Pipe.**

**8-Inch, Bid Item 70010; 10-Inch, Bid Item 70011; 12-Inch, Bid Item 70012; 16-Inch, Bid Item 70013; 20-Inch, Bid Item 70014; 24-Inch, Bid Item 70015.**

##### **704.4.1 Description:**

- (1) Furnish, assemble, install and test horizontal directional-drilled water pipe and fittings. Work for this item also includes:
  1. Excavating boring pits and other trenches. Backfilling and compacting said excavations.
  2. Exposing existing water mains to verify location and depth.
  3. Installing tracer wire, joint adapters, bracing, plugs and other accessories.
  4. Hard-rock drilling.
  5. Disposing of surplus material.
  6. Restoring the work area.

##### **704.4.2 Materials:**

- (1) Refer to Article 702 and this section.
- (2) High-Density Polyethylene (HDPE), as described herein, is the approved standard pipe material for Horizontal Directional-Drilling pipe installations.
  1. If proposing to use pipe material other than HDPE for horizontal directional-drilling, submit full material specifications to the Engineer for review per Article 703 – ‘Repairs and Alterations.’
  2. Any proposed alternative material needs to have been used on a minimum of five similarly sized horizontal directional-drilling projects within the last three years to be considered.
- (3) HDPE Pipe Requirements:
  1. In compliance with AWWA C906 – latest edition, ASTM F714 – latest edition.
  2. 200 psi pressure rating.
  3. DR-11 dimension ratio.
  4. Match inside diameter as closely as practical to the inside diameter of the connection pipe.
  5. Outside diameters shall be Ductile Iron Outside Diameter (DIOD).
  6. Comply with the requirements of the Safe Drinking Water Act and certified as suitable for drinking water by ANSI/NSF Standard 61.
  7. Identified as water with either a factory installed co-extruding longitudinal blue stripe in the pipe or blue underground warning tape with “Caution Buried Water Line Below” imprinted on it, placed 2-feet above the new pipe.

8. Cuts or gouges in the HDPE pipe, per ASTM F585 are acceptable up to 10% of the wall thickness. Cut out and remove any pipe sections where cuts or gouges are greater than 10% of the wall thickness and butt fuse the ends.
- (4) Joining HDPE pipe to HDPE pipe *or* HDPE fittings:
  1. Thermal butt fusion.
  2. Thermal butt fusion is to be executed in accordance with the requirements of the pipe and/or fitting manufacturer. Equipment used to execute the thermal butt fusion joints shall be furnished or approved by the pipe and/or fitting manufacturer.
- (5) HDPE pipe joints to valve joints *or* ductile iron pipe:
  1. HDPE mechanical joint adapter with restraining device (Electrofusion Flex Restraint) and a concrete collar (cast in-place).
  2. Concrete collars are to meet specifications of Article 703 – ‘Thrust Restraint’ and the Standard Detail Drawings.
- (6) Mechanical Joint Adapters:
  1. Join HDPE pipe to mechanical joint bells in accordance with the requirements of ANSI/AWWA C111/A21.11.
  2. Mechanical joint adapters shall be certified to meet the requirements of ANSI/AWWA C901 and C906 requirements (latest revisions).
  3. Thermal butt fusion is required at joints between mechanical joint adapters and HDPE pipe.
- (7) Tracer Wire:
  1. Galvanized or stainless steel.
  2. ¼-inch diameter braided cable.
  3. 2,000-lb minimum breaking strength.
  4. Protective PVC coating (to resist corrosion and damage during installation).

**704.4.3 Construction:**

- (1) Refer to Article 703 and this section.
- (2) Prior to bidding, become familiar with anticipated subsurface and existing field conditions that will affect the location of the bore pits and the lengths and depths of the pipe installation, as well as any equipment, tools and materials required to keep the necessary installation within the limits identified on the drawings.
- (3) The Contract Documents represent the best information available with regard to anticipated field conditions; however, any provisions necessary for encountering hard-rock drilling are to be included and are considered incidental to the installation.
- (4) Exposing existing water mains to verify location is considered incidental to the installation.

Part VII - Water Mains and Service Laterals

- (5) Submit a horizontal directional-drilling plan, sequence of work, and drilling schedule to the Engineer for review prior to commencing work. At a minimum, include:
  - 1. Detailed site plan drawing which depicts location and size of boring pits and staging areas.
  - 2. Proposed sequence and schedule of HDD operations.
  - 3. Method of controlling and monitoring **and recording** the bore location, accuracy, and depth.
  - 4. Drilling mud storage, handling and contingency plan.
  - 5. Any other applicable details regarding how the work will progress and be controlled.
- (6) The Engineer will review the precision of the installed pipe. For gross misalignment, the Engineer reserves the right to require that the pipe be reinstalled at no cost to the City. Maintain liability for all costs associated with modifying to easements due to HDPE installation alignment errors. Pipe installation accuracy requirements:
  - 1. Horizontal accuracy of +/- 3-feet.
  - 2. Vertical accuracy of plus 6-inches and minus 3-feet.
- (7) Perform pipe joining with personnel trained by the thermal fusion equipment manufacturer in the use of the equipment for thermal butt fusion/electro-fusion of HDPE pipe.
- (8) Install tracer wire along the full length of the pipe. Bring the tracer wire up to finish grade at each end of the bore inside a valve box to allow access for future use. Securely clamp or weld the tracer wire to the valve box.

**704.4.4 Method of Measurement:**

- (1) Measured by length in feet, to the nearest half-foot for each size (diameter) of pipe installed.
- (2) Measured along the centerline of the pipe from center-to-center of valves and fittings.
- (3) No deductions will be taken from the measured lengths for fitting installations. No additions to the length of the pipe will be given due to misalignment of the bore.

**704.4.5 Basis of Payment:**

- (1) Paid at the contract unit prices under the following bid items:

<b>ITEM NUMBER</b>	<b>DESCRIPTION</b>	<b>UNIT</b>
70010	HORIZONTAL DIRECTIONAL DRILL 8 INCH PIPE	L.F.
70011	HORIZONTAL DIRECTIONAL DRILL 10 INCH PIPE	L.F.
70012	HORIZONTAL DIRECTIONAL DRILL 12 INCH PIPE	L.F.
70013	HORIZONTAL DIRECTIONAL DRILL 16 INCH PIPE	L.F.
70014	HORIZONTAL DIRECTIONAL DRILL 20 INCH PIPE	L.F.
70015	HORIZONTAL DIRECTIONAL DRILL 24 INCH PIPE	L.F.

- (2) Valve boxes required for tracer wire endpoints are to be paid separately.

### 704.5 Furnish & Install Casing.

18-Inch, Bid Item 70020; 20-Inch, Bid Item 70021; 24-Inch, Bid Item 70022; 30-Inch, Bid Item 70023.

#### 704.5.1 Description:

- (1) Install steel or reinforced concrete casing pipes for water mains.

#### 704.5.2 Materials:

- (1) Refer to Article 702 and this section.
- (2) Steel Casing Pipe:
  1. Minimum yield strength of 35,000 psi.
  2. Minimum wall thickness:

Pipe Diameter (inches)	Wall Thickness (inches)
18	0.31250
20	0.34375
24	0.37500
30	0.46875

- (3) Reinforced Concrete Pipe:
  1. Class V minimum.
- (4) Carrier Pipe:
  1. US Pipe TR-Flex, or equivalent.
- (5) Casing fill:
  1. Silica sand or pea gravel.

#### 704.5.3 Construction:

- (1) Prior to installation of the pipe casing, perform required ULOs to verify the location of surrounding utilities and structures. Provide utility location information to the Engineer for review and approval of any adjustments in casing installation line or grade, in writing.
- (2) Install per the approved drawings to an accuracy of +/- 1% or +/- 2-feet, whichever is less.
- (3) Install the pipe casing by traditional open trench construction wherever applicable.
- (4) For untrenched installation of the pipe casing, install by dry auger boring and jacking methods.
- (5) Requirements:
  1. Borehole diameter to be essentially the same as the outside diameter of the casing.
  2. Auger is to remain inside the casing at all times.



Part VII - Water Mains and Service Laterals

3. Pressure-grout the annular space around the casing if the auger is pushed ahead of the casing.
  4. Pressure grout voids as they develop.
  5. Pressure-grout any spaces greater than approximately 1-inch from the outside of the casing.
  6. Provide a steerable front section of casing to allow vertical grade adjustments.
  7. Provide a water level or other means to monitor the grade elevation of the auger casing.
  8. Water jacking for excavation of the soil is not permitted.
- (6) Provide a boring and jacking plan to the Engineer for review and approval prior to commencing work.
  - (7) Connect adjacent lengths of steel pipe by continuous, circumferential, field butt-welding in accordance with AWWA C206.
  - (8) Install carrier pipe on line and grade through the casing pipe.
  - (9) Install approved casing spacers at the required distances (see Standard Detail Drawings).
  - (10) Fill the annular space between the casing and carrier pipe with specified sand or gravel material.
  - (11) Take care to ensure that developed thrust pressures do not disturb existing utilities in or around the bore pit area.
  - (12) Properly dispose of excess material off-site.

**704.5.4 Method of Measurement:**

- (1) Measured by length in feet, to the nearest half foot for each size (diameter) of casing installed.
- (2) Measured along the centerline, from end to end of the casing.

**704.5.5 Basis of Payment:**

- (1) Paid at the contract unit prices under the following bid items:

<b>ITEM NUMBER</b>	<b>DESCRIPTION</b>	<b>UNIT</b>
70020	FURNISH AND INSTALL 18 INCH STEEL CASING	L.F.
70021	FURNISH AND INSTALL 20 INCH STEEL CASING	L.F.
70022	FURNISH AND INSTALL 24 INCH STEEL CASING	L.F.
70023	FURNISH AND INSTALL 30 INCH STEEL CASING	L.F.

**704.6 Furnish & Install Water Valve.**

**4-Inch, Bid Item 70030; 6-Inch, Bid Item 70031; 8-Inch, Bid Item 70032; 10-Inch, Bid Item 70033; 12-Inch, Bid Item 70034; 16-Inch, Bid Item 70035; 20-Inch, Bid Item 70036.**

**704.6.1 Description:**

- (1) Furnish and install water main valves and associated accessories. Work for this item also includes, but is not limited to:
  - 1. Mechanical joint restraint:
  - 2. Valve boxes and box extensions.
  - 3. Valve box adjustments.

**704.6.2 Materials:**

- (1) Refer to Article 702 and this section.
- (2) Valves 12-inches and smaller - Requirements:
  - 1. Resilient Wedge Gate Valves.
  - 2. Meets the requirements of AWWA C509- latest revision.
  - 3. Supplied with mechanical joints.
  - 4. Supplied with conductive mechanical joint (no lead) gaskets.
  - 5. Open to the left.
  - 6. Non-rising stem.
  - 7. O-ring packing.
  - 8. 2-inch square operating nut.
  - 9. Acceptable models include:

<b>Brand</b>	<b>Model</b>
Kennedy	K4571 or equal
Mueller	A2360 or equal
Clow	F6100 or equal
AFC	Series 500 or equal – <i>OR</i> – Series 2500 or equal

- (3) Valves 16-inches and larger - Requirements:
  - 1. Rubber Seated Butterfly Valves.
  - 2. Meets the requirements of AWWA C504 - latest revision.
  - 3. Supplied with mechanical joints.
  - 4. Supplied with conductive mechanical joint (no lead) gaskets.

Part VII - Water Mains and Service Laterals

5. Open to the left.
6. Acceptable models include:

<b>Brand</b>	<b>Model</b>
Kennedy	B4500 or equal
Mueller	B3211-20 or equal

(4) Valve boxes:

1. Bingham and Taylor cast-iron, size “DD”, 50-inches to 70-inches.
2. Three piece screw type.
3. No. 6 round base.
4. 5-1/4-inch shaft.
5. With stay-put covers marked “WATER.”.

(5) Valve Box Alignment Devices:

1. All valves shall be supplied with a Gate Valve Adaptor as manufactured by Adaptor Inc., or equal.
2. Metal frame
3. Supplied with 3/4-inch rubber gasket.
4. Sized to fit the brand of valve being supplied.

(6) Valve Box Extensions:

1. Tyler, or equal
2. Screw type
3. 5-1/4-IN shaft
4. No. 58 - 12-IN long,
5. No. 59 - 18-IN long,
6. No. 60 - 26-IN long.

**704.6.3 Construction:**

- (1) Refer to Article 703 and this section.
- (2) Prior to installation, inspect all valves and associated accessories for:
  1. Cracks or other handling damages.
  2. Verification of bolt tightness.
  3. Opening direction and number of turns to open.

Part VII - Water Mains and Service Laterals

4. Freedom of operation.
5. Cleanliness of valve ports, especially seating surfaces.
- (3) Set and join valves and associated accessories to the pipe with mechanical joints per Article 703.
- (4) Always install valves in the closed position to prevent foreign material from causing damage.
- (5) Adjust valves following installation so they operate easily and properly.
- (6) A valve box is required at every valve installation. Valve box installation requirements:
  1. Ensure that the valve box does not transmit shock or stress to the valve.
  2. Center the valve box over the valve operating nut using the valve box alignment device.
  3. Set the box cover ¼-inch to ½-inch below the finished surface.
  4. Verify that there is adequate adjustment in the valve box to reach proper grade without the use of “cheaters”.
  5. Reset any valve boxes that have shifted so they are plumb and centered over the valve at any time throughout construction, and until formal acceptance of the project by the Engineer.

**704.6.4 Method of Measurement:**

- (1) Measured by each completed unit.

**704.6.5 Basis of Payment:**

- (1) Paid at the contract unit prices under the following bid items:

<b>ITEM NUMBER</b>	<b>DESCRIPTION</b>	<b>UNIT</b>
70030	FURNISH AND INSTALL 4-INCH WATER VALVE	EACH
70031	FURNISH AND INSTALL 6-INCH WATER VALVE	EACH
70032	FURNISH AND INSTALL 8-INCH WATER VALVE	EACH
70033	FURNISH AND INSTALL 10-INCH WATER VALVE	EACH
70034	FURNISH AND INSTALL 12-INCH WATER VALVE	EACH
70035	FURNISH AND INSTALL 16-INCH WATER VALVE	EACH
70036	FURNISH AND INSTALL 20-INCH WATER VALVE	EACH

**704.7 Furnish and Install Hydrant.**

**Bid Item 70040.**

**704.7.1 Description:**

- (1) Furnish and install fire hydrants and associated thrust restraints. Adjust hydrant as necessary.
- (2) Prepare a proper drain field for the hydrant.
- (3) Restore all disturbed terrace or turf areas.

**704.7.2 Materials:**

- (1) Refer to Article 702 and this section.
- (2) Hydrant requirements:
  - 1. Hydrants are required to have “breakaway” capability
  - 2. Acceptable models include:

<b>Brand</b>	<b>Model</b>
AFC Waterous	Pacer WB-67
Mueller	Super Centurion A423

- (3) Nozzle requirements:
  - 1. Side nozzles: Two at 2½-inch diameter.
  - 2. Pumper nozzle: One at 4½-inch diameter.
  - 3. National Standard threads.
  - 4. Chains attaching the caps to the hydrant.
  - 5. Embossed with the word OPEN and an arrow showing that the hydrant opens left.
  - 6. Valve opening: 5¼-inch with National Standard operating nut shape.
  - 7. Painted red with blue nozzle caps – Waterous color M4152 (Houston Blue), or equal.
  - 8. 360-degree top rotation.
  - 9. “Dry top” operating threads to be sealed when open.
  - 10. 6-inch mechanical joint bottom connection with conductive mechanical joint (no lead) gasket and necessary accessories.
- (4) Upper valve plate requirements:
  - 1. Brass with a brass-to-brass foot valve.
- (5) Drain valve facing requirements:
  - 1. Furnish hydrant with plastic drain valve facing (otherwise, drain tube/drain valve assembly).

## Part VII - Water Mains and Service Laterals

- (6) Reflective locating device:
  - 1. “Hydra-Finder” manufactured by RoDon Corp.
- (7) Extensions: Per manufacturer’s recommendations.

### **704.7.3 Construction:**

- (1) Refer to Article 703 and this section.
- (2) Ensure that the Engineer is present whenever:
  - 1. A hydrant is to be set.
  - 2. A hydrant has been set, prior to backfilling.
  - 3. A hydrant extension is to be installed.
  - 4. A hydrant is to be disassembled for adjustment or maintenance.
- (3) Be responsible for the proper operation of all hydrants on the project until the City formally accepts the water mains, and the warranty period has expired.
- (4) Unless directed otherwise, set all hydrants so the back of the hydrant is 8-feet from the associated property line.
- (5) Ensure that the hydrant is set so the bury-line is not below finished grade and not more than 3-inches above finished grade.
- (6) The base of the hydrant barrel may not exceed a depth of 9-feet below finished grade.
- (7) Hydrant extensions:
  - 1. Extensions may be necessary to bring the bury-line to finish grade.
  - 2. Notify the Engineer at least 2 working days prior to installing an extension.
  - 3. Coordinate with the Engineer to have the extension furnished.
  - 4. When an extension becomes necessary as a result of Engineer-ordered grade adjustments during construction or plan revisions issued by the Engineer, the City will furnish the extension and the installation labor.
  - 5. When an extension is necessary as a result of negligence, or when the planned depth is greater than the available hydrant length, supply an approved extension. Do not install the extension until the Engineer is present.
  - 6. No more than 1 hydrant extension will be permitted per hydrant installation.
  - 7. Note that any subsequent adjustments to the hydrant elevation, including any extra fittings needed to meet these requirements, are considered incidental to the hydrant installation.
- (8) Restrain the full length of hydrants lead from the tee on the water main to the hydrant, including the hydrant valve and any associated fittings, with mechanical joint restraints. Push-on pipe joints are not permitted along the hydrant lead unless there is a continuous pipe dimension on

the lead longer than the full-length of a new pipe. Under that condition, an approved joint-restraint locking gasket is required at the joint.

- (9) Install a 4-inch x 8-inch x 16-inch solid concrete masonry unit, laid flat, in the excavation to provide a firm base for the hydrant.
- (10) Install solid concrete or poured concrete thrust blocking against undisturbed soil behind the base of the hydrant in accordance with Article 703 of these Standard Specifications.
- (11) Set the hydrant in a truly vertical position and securely brace it until backfilling is complete.
- (12) Rotate the hydrant so that the small nozzles are parallel to the curb line.
- (13) Use 1-inch washed stone as backfill around the lower portion of the hydrant. Take special care to keep the weep holes/drain holes in the hydrant elbow open to allow drainage.
- (14) Cover the stone backfill with 6-mil polyethylene, or suitable geotextile fabric, to prevent loose dirt from filling in the voids in the stones.
- (15) Backfill the remainder of the excavation with approved material and compact evenly in lifts not exceeding 12-inches. Ensure that the pressure of the backfill on the stem is evenly distributed.
- (16) Restore all disturbed turf areas associated with the hydrant installation.

**704.7.4 Method of Measurement:**

- (1) Measured by each completed unit.

**704.7.5 Basis of Payment:**

- (1) Paid at the contract unit prices under the following bid items:

ITEM NUMBER	DESCRIPTION	UNIT
70040	FURNISH AND INSTALL HYDRANT	EACH

**704.8 Relocate Hydrant.**

**Bid Item 70041.**

**704.8.1 Description:**

- (1) Remove and relocate existing fire hydrants.

**704.8.2 Materials:**

- (1) Refer to Article 702 and this section.
- (2) (Vacant)

**704.8.3 Construction:**

- (1) Refer to Article 703 and this section.
- (2) If the hydrant lead valve is adequately restrained to the water main tee:
  - 1. Shut off the hydrant lead valve and excavate as necessary along the hydrant lead.
  - 2. Add or remove fittings, extending or shortening the hydrant lead as shown on the drawings or as ordered by the Engineer, to properly install the hydrant in accordance with Article 704 – ‘Furnish & Install Hydrant’.
- (3) If the hydrant does not have a valve, or if the valve is not adequately restrained to the main:
  - 1. Shut off the water main after coordinating with the Engineer.
  - 2. Excavate along the hydrant lead and cut the lead.
  - 3. Install valve per Article 704 and securely restrain the new valve back to the water main tee.
  - 4. Return the water main to service as soon as practical and safe.
  - 5. Add or remove fittings, extending or shortening the hydrant lead as shown on the drawings or as ordered by the Engineer to properly install the hydrant in accordance with Article 704 – ‘Furnish & Install Hydrant’.
- (4) Backfill and compact the excavation to an elevation 6-inches below the finished grade of the street terrace in accordance with Article 704 – ‘Furnish & Install Hydrant’.
- (5) Restore all disturbed turf areas associated with the hydrant relocation/installation.

**704.8.4 Method of Measurement:**

- (1) Measured by each completed unit.

**704.8.5 Basis of Payment:**

- (1) Paid at the contract unit prices under the following bid items:

ITEM NUMBER	DESCRIPTION	UNIT
70041	RELOCATE HYDRANT	EACH



## **704.9 Furnish & Install Water Service Laterals.**

**1-Inch, Bid Item 70050; 1½-Inch, Bid Item 70051; 2-Inch, Bid Item 70052.**

### **704.9.1 Description:**

- (1) Install new copper service laterals and related accessories. Work for this item also includes:
  1. Tapping the water main and installing or repairing polyethylene water main encasement.
  2. Installing the associated service lateral fittings and curb box.
  3. Adjusting the new curb box to finished grade.
  4. Removing any existing curb stops/curb boxes inside the excavated service ditch.
  5. Restoration of disturbed terrace or turf areas.

### **704.9.2 Materials:**

- (1) Refer to Article 702 and this section.
- (2) (Vacant)

### **704.9.3 Construction:**

- (1) Refer to Article 703 and this section.
- (2) Whenever possible, install the curb stop on the service at a point 8-feet from the property line.
- (3) Install a 4-inch x 8-inch x 8-inch solid concrete masonry unit, laid flat, in the excavation to provide a firm base for the curb stop.
- (4) Adequately wrap the curb stop with polyethylene wrap to prevent debris from entering or impacting the operability of the curb stop.
- (5) Install the curb box vertically over the curb stop so that after the service is backfilled to final grade, a key may be placed on the rod of the curb stop and it may be operated easily.
- (6) Set curb boxes flush with the finished ground elevation.
- (7) Do not locate curb boxes in curb, sidewalk, driveways, or within 5-feet of the base of trees.
- (8) When backfilling new service lateral trenches:
  1. Place a 2-inch x 4-inch board next to each curb or valve box in the terraces.
  2. Ensure that the board is at least 4-feet long, with at least 2-feet buried and 2-feet exposed.
- (9) Following installation, open the corporation stop and the curb stop, and flush out the service lateral. Once flushed, securely install a plug or copper end cap to keep rocks and dirt out of the lateral.
- (10) Leave the corporation stop open.

Part VII - Water Mains and Service Laterals

- (11) Restore any disturbed terrace or turf areas associated with the lateral installation. The restoration is considered incidental to the service lateral work.

**704.9.4 Method of Measurement:**

- (1) Measured by length in feet along the centerline of the service lateral at the surface, from the center of the water main to the center of the curb stop.
- (2) If the Engineer relocates a curb stop due to conflict, tail extensions beyond the curb stop will be paid along the centerline of the service lateral at the surface from the curb stop to the property service connection.

**704.9.5 Basis of Payment:**

- (1) Paid at the contract unit prices under the following bid items:

ITEM NUMBER	DESCRIPTION	UNIT
70050	FURNISH AND INSTALL 1 INCH SERVICE LATERALS	L.F.
70051	FURNISH AND INSTALL 1½ INCH SERVICE LATERALS	L.F.
70052	FURNISH AND INSTALL 2 INCH SERVICE LATERALS	L.F.

**704.10 Replace Service Lateral.**

**1-Inch, Bid Item 70053; 1½-Inch, Bid Item 70054; 2-Inch, Bid Item 70055.**

**704.10.1 Description:**

- (1) Abandon existing service lateral and replace it with a new service lateral. Typically a result of:
  - 1. Tree ordinance restrictions (see Article 107).
  - 2. Utility conflicts, or driveway approach/pavement conflicts.
  - 3. Broken curb stops or damage to the existing copper tubing on the existing lateral.
  - 4. The request of the Engineer.

**704.10.2 Materials:**

- (1) Refer to Article 702 and this section.
- (2) (Vacant)

**704.10.3 Construction:**

- (1) Refer to Article 703 and this section.
- (2) Allow for any services designated for replacement on the plans to first be reexamined by the Engineer in order to determine the necessity for replacement and evaluate alternatives.
- (3) Alternatives to the indicated total replacement may include a combination of:
  - 1. Extending/reconnecting a service lateral per Article 704.
  - 2. Disconnecting/reconnecting a service lateral per Article 704.
  - 3. Replacing a curb stop/box per Article 704.
- (4) If the Engineer determines the existing service lateral shall be replaced, abandon the existing service lateral and install a new service lateral in accordance to Article 704 – ‘Furnish & Install Water Service Lateral’.

**704.10.4 Method of Measurement:**

- (1) Refer to Article 704 – ‘Furnish & Install Water Service Lateral’.

**704.10.5 Basis of Payment:**

- (1) Paid at the contract unit prices under the following bid items:

ITEM NUMBER	DESCRIPTION	UNIT
70053	REPLACE 1-INCH COPPER SERVICE LATERAL	EACH
70054	REPLACE 1½-INCH COPPER SERVICE LATERAL	EACH
70055	REPLACE 2-INCH COPPER SERVICE LATERAL	EACH

**704.11 Extend and Reconnect Service Lateral.**

**1-Inch, Bid Item 70056; 1½-Inch, Bid Item 70057; 2-Inch, Bid Item 70058.**

**704.11.1 Description:**

- (1) Connect-to and extend existing water service laterals to the new water main. Restore any disturbed terrace areas, as necessary.

**704.11.2 Materials:**

- (1) Refer to Article 702 and this section.
- (2) (Vacant)

**704.11.3 Construction:**

- (1) Refer to Article 703 and this section.
- (2) Excavate to expose the existing water main at the existing service connection.
- (3) Cut-off the service pipe at the exposed location.
- (4) Couple the disconnected end of the service with a new service of the designated size.
- (5) Extend the new copper lateral to the new water main and connect the new service tubing to the corporation stop on the new water main.

**704.11.4 Method of Measurement:**

- (1) Measured by length in feet along the centerline of the pipe at the surface, from the center of the water main to the point of the connection.

**704.11.5 Basis of Payment:**

- (1) Paid at the contract unit prices under the following bid items:

ITEM NUMBER	DESCRIPTION	UNIT
70056	EXTEND AND RECONNECT 1-INCH SERVICE LATERAL	L.F.
70057	EXTEND AND RECONNECT 1½-INCH SERVICE LATERAL	L.F.
70058	EXTEND AND RECONNECT 2-INCH SERVICE LATERAL	L.F.

**704.12 Disconnect / Reconnect Service Lateral.**

**1-Inch, Bid Item 70059; 1½-Inch, Bid Item 70060; 2-Inch, Bid Item 70061.**

**704.12.1 Description:**

- (1) Cut off, and typically shorten, existing copper water service laterals and connect the lateral to the new water main. **Restore any disturbed terrace areas, as necessary.**

**704.12.2 Materials:**

- (1) Refer to Article 702 and this section.
- (2) (Vacant).

**704.12.3 Construction:**

- (1) Refer to Article 703 and this section.
- (2) Excavate and expose the existing service lateral at the location of the new water main crossing.
- (3) Cut-off the service tubing at the exposed crossing location.
- (4) Couple the disconnected end of the service tubing with a new service of the designated size.
- (5) Reconnect the modified service length to the corporation stop on the new water main.

**704.12.4 Method of Measurement:**

- (1) Measured by each completed unit.

**704.12.5 Basis of Payment:**

- (1) Paid at the contract unit prices under the following bid items:

<b>ITEM NUMBER</b>	<b>DESCRIPTION</b>	<b>UNIT</b>
70059	DISCONNECT / RECONNECT 1-INCH SERVICE LATERAL	EACH
70060	DISCONNECT / RECONNECT 1½-INCH SERVICE LATERAL	EACH
70061	DISCONNECT / RECONNECT 2-INCH SERVICE LATERAL	EACH

**704.13 Select Fill – Sand for Water.**

**Bid Item 70070.**

**704.13.1 Description:**

- (1) Install select imported fill from outside of the project, to be placed in the trenches as specified in the Contract Documents.
- (2) Excess excavated material resulting from this work is considered surplus material; dispose of at no additional cost to the City.

**704.13.2 Materials:**

- (1) Refer to Article 702 and this section.
- (2) As defined in Article 202.
- (3) Under no circumstances will asphalt material of any size or foreign debris be allowed in the backfill material.

**704.13.3 Construction:**

- (1) Refer to Article 703 and this section.
- (2) (Vacant).

**704.13.4 Method of Measurement:**

- (1) Measured by length in feet along the centerline of the pipe at the surface for new installations, to the nearest foot.
- (2) When excavating for maintenance or abandonment items:
- (3) Measured along the centerline of the trench.
- (4) The Engineer may require truck delivery tickets to substantiate compensation.

**704.13.5 Basis of Payment:**

- (1) Paid at the contract unit prices under the following bid items:

ITEM NUMBER	DESCRIPTION	UNIT
70070	SELECT FILL – SAND FOR WATER	L.F.

- (2) If a specific pay item for Select Fill is not provided in the Contract Documents, the specified and required Select Fill is considered to be incidental to the cost of the work and no additional payment will be made.

**704.14 Cut-In or Connect-To Existing Water System.**

**Bid Item 70080.**

**704.14.1 Description:**

- (1) Cut-In Connection consists of all means and methods, equipment, tools, labor, and incidentals necessary for making a plug-removal connection or a cut-in connection to existing water mains, including any necessary water-tight capping of existing water mains associated with the work.

**704.14.2 Materials:**

- (1) Refer to Article 702 and this section.
- (2) (Vacant).

**704.14.3 Construction:**

- (1) Refer to Article 703 and this section.
- (2) Excavate and expose the existing water main to a point 18-inches below the bottom of the pipe at the proposed location of the plug-removal connection or cut-in connection.
- (3) Shut off all valves required to isolate the exposed pipe segment. Be responsible and properly equipped for valve-turning at all times while doing such work.
- (4) Place a water pump at the bottom of the excavation for dewatering, as needed. When cutting out sections of pipe proceed slowly and ensure dewatering efforts prevent the water level within the excavation from rising above the invert elevation of the exposed pipe.
- (5) Before placing new pipe and fittings on the exposed end of the existing fitting or the cut-off end of the existing pipe, disinfect the new fitting or valve by swabbing or soaking thoroughly with a 10:1 (water:bleach) solution.
- (6) Fasten new fittings to existing fittings or ductile iron pipes as described in Article 703. For connections to existing cast iron or other existing pipe materials, secure the new pipe or fitting with threaded rods in accordance with the Standard Detail Drawings.
- (7) For cut-in connections or as otherwise necessary, secure the disconnected end of the existing pipe with either a pipe plug or a cap fitting, as approved by the Engineer. Place standard thrust blocking between the end of the existing pipe and the new fitting, unless specified otherwise in the Contract Documents or as directed by the Engineer.

**704.14.4 Method of Measurement:**

- (1) Measured by each completed unit.

**704.14.5 Basis of Payment:**

- (1) Paid at the contract unit prices under the following bid items:

ITEM NUMBER	DESCRIPTION	UNIT
70080	CUT-IN CONNECTION	EACH

**704.15 Furnish Excavation and Ditch for Live Tap.**

**Bid Item 70081.**

**704.15.1 Description:**

- (1) Excavate and prepare the ditch for the City to perform a live-tap connection on an existing water main. Upon completion of tap, cut-off and cap the existing water main.

**704.15.2 Materials:**

- (1) Refer to Article 702 and this section.
- (2) (Vacant).

**704.15.3 Construction:**

- (1) Refer to Article 703 and this section.
- (2) Prepare a suitable work area in the ditch for the Engineer to perform the live-tap:
- (3) Expose the water main across the full width of the ditch.
- (4) Provide at least 1-foot of clear space around the circumference of the exposed water main.
- (5) Locate and identify the proposed tap location in the ditch and adjust as necessary to maintain a distance of at least 18-inches from the nearest joint.
- (6) Provide at least a 4-foot-wide clear working area, extending at least 6-feet perpendicular from the main at the location of the live-tap.
- (7) Upon completion of the live-tap by the City, cut-off and cap the existing water main in accordance to Article 704 – ‘Cut Off Existing Water Main’. The cut-off and cap work associated with the live-tap is incidental to the work and will not be paid separately.

**704.15.4 Method of Measurement:**

- (1) Measured by each completed unit.

**704.15.5 Basis of Payment:**

- (1) Paid at the contract unit prices under the following bid items:

ITEM NUMBER	DESCRIPTION	UNIT
70081	FURNISH EXCAVATION AND DITCH FOR LIVE TAP	EACH



**704.16 Cut Off Existing Water Main.**

**Bid Item 70082.**

**704.16.1 Description:**

- (1) Abandon and plug a segment of existing water main by “cutting it off” from the active water system. The work also includes securely capping or plugging the cut end of the active main.

**704.16.2 Materials:**

- (1) Refer to Article 702 and this section.
- (2) (Vacant).

**704.16.3 Construction:**

- (1) Refer to Article 703 and this section.
- (2) Prior to proceeding with the cut-off, perform the required water main shut-off notifications.
- (3) When authorized to proceed, isolate and shut-off the existing water main.
- (4) Cut of the water main at the location designated for abandonment.
- (5) Install a concrete pipe plug in the end of the existing main which is to be abandoned.
- (6) On the end of the water main which is to remain in-service:
  - 1. Install a restrained mechanical joint cap over the cut end of the existing water main, or within 2-feet of a fitting or live-tap.
  - 2. Otherwise, install a restrained mechanical joint plug fitting into a new or existing fitting located at the end of the main.
- (7) If the water main cut off work is intended to remove and replace an existing fitting, valve, or segment of pipe, cut off as designated, remove the existing material and replace it with the new fittings and/or the lengths of pipe and solid sleeves necessary to reconnect to the existing main.
- (8) Disinfect any associated materials by swabbing methods in accordance to Article 703.

**704.16.4 Method of Measurement:**

- (1) Measured by each completed unit.

**704.16.5 Basis of Payment:**

- (1) Paid at the contract unit prices under the following bid items:

<b>ITEM NUMBER</b>	<b>DESCRIPTION</b>	<b>UNIT</b>
70082	CUT OFF EXISTING WATER MAIN	EACH

**704.17 Abandon Water Valve Box.**

**Bid Item 70090.**

**704.17.1 Description:**

- (1) Abandon valve boxes within the project limits that are set upon valves no longer in service.
- (2) Place the abandoned valve in the closed position prior to abandoning the box.
- (3) Completely remove the valve box whenever possible.

**704.17.2 Materials:**

- (1) Refer to Article 702 and this section.
- (2) (Vacant).

**704.17.3 Construction:**

- (1) Refer to Article 703 and this section.
- (2) Proceed with work only after the existing water main has been abandoned.
- (3) Remove the top casting of the valve box to a point at least 3-feet below the final elevation, and then backfill the opening.

**704.17.4 Method of Measurement:**

- (1) Measured by each completed unit.

**704.17.5 Basis of Payment:**

- (1) Paid at the contract unit prices under the following bid items:

<b>ITEM NUMBER</b>	<b>DESCRIPTION</b>	<b>UNIT</b>
70090	ABANDON WATER VALVE BOX	EACH

**704.18 Abandon Hydrant.**

**Bid Item 70091.**

**704.18.1 Description:**

- (1) Decommission and salvage designated existing fire hydrants. Restore any disturbed turf areas.

**704.18.2 Materials:**

- (1) Refer to Article 702 and this section.
- (2) (Vacant).

**704.18.3 Construction:**

- (1) Refer to Article 703 and this section.
- (2) Do not proceed with hydrant abandonments until the existing water main has been abandoned.
- (3) For screw type hydrants:
  - 1. Unscrew the hydrant with chain tongs (or like), and remove the high stock, and salvage for the Engineer.
  - 2. Remove the frost case and salvage for the Engineer.
- (4) For non-screw type hydrants:
  - 1. Excavate to the bottom of the hydrant and disassemble/disconnect it from the hydrant lead.
  - 2. Remove the hydrant and salvage for the Engineer.
- (5) Backfill the remaining opening/excavation with existing material and compact.
- (6) Use select fill as additional material if there is not enough approved existing backfill material.
- (7) Restore all disturbed turf areas associated with the hydrant abandonment.

**704.18.4 Method of Measurement:**

- (1) Measured by each completed unit.

**704.18.5 Basis of Payment:**

- (1) Paid at the contract unit prices under the following bid items:

ITEM NUMBER	DESCRIPTION	UNIT
70091	ABANDON HYDRANT	EACH

- (2) Hydrants that are damaged due to negligence will not be paid.
- (3) Hydrants damaged during this work will be billed \$635.00 by the Engineer.

**704.19 Abandon Water Valve Access Structure.**

**Bid Item 70092.**

**704.19.1 Description:**

- (1) Abandon all designated water valve access structures or manholes within the project limits.
- (2) If the valve is to remain active, install a valve box.

**704.19.2 Materials:**

- (1) Refer to Article 702 and this section.
- (2) (Vacant).

**704.19.3 Construction:**

- (1) Refer to Article 703 and this section.
- (2) Remove the existing casting and the structure walls.
- (3) If concrete is in contact with a main and/or valve that is to remain in service, and removal of the structure may damage the existing piping system, the Engineer may instead require that the structure walls be removed to a depth of 3-feet below finished grade.
- (4) If the existing valve is to remain in use, remove and replace the water valve access structure with a valve box per Article 704.
- (5) Use select fill as additional backfill material if there is not enough approved existing material.

**704.19.4 Method of Measurement:**

- (1) Measured by each completed unit.

**704.19.5 Basis of Payment:**

- (1) Paid at the contract unit prices under the following bid items:

<b>ITEM NUMBER</b>	<b>DESCRIPTION</b>	<b>UNIT</b>
70092	ABANDON WATER VALVE ACCESS STRUCTURE	EACH

**704.20 Furnish and Install Styrofoam.**

**Bid Item 70101.**

**704.20.1 Description:**

- (1) Install Styrofoam to insulate water mains and/or water service laterals.
- (2) Styrofoam insulation is required when:
  - 1. The top of water main has 5-feet of cover or less.
  - 2. The water main crosses below storm sewer.
  - 3. When otherwise specified on the drawings or as directed by the Engineer.

**704.20.2 Materials:**

- (1) Refer to Article 702 and this section.
- (2) Styrofoam requirements:
  - 1. Thickness: 2-inch (minimum).
  - 2. Minimum strength: 25 psi.
  - 3. High-density polystyrene board as manufactured by Dow Chemical Co., or equal.
  - 4. 4-foot by 8-foot sheets.

**704.20.3 Construction:**

- (1) Refer to Article 703 and this section.
- (2) After pipe installation, backfill and compact the trench to a level 6-inches above the top of pipe. Place insulation board in the trench centered over the pipe on a level surface in order to provide proper support for the insulation.
- (3) Following installation of the Styrofoam, backfill and compact the remainder of the trench.

**704.20.4 Method of Measurement:**

- (1) Measured along the centerline of the pipe at the surface, by length in feet of pipe effectively insulated.

**704.20.5 Basis of Payment:**

- (1) Paid at the contract unit prices under the following bid items:

<b>ITEM NUMBER</b>	<b>DESCRIPTION</b>	<b>UNIT</b>
70101	FURNISH AND INSTALL STYROFOAM	L.F.

**704.21 Landscape Restoration for Water Main.**

**Bid Item 70102.**

**704.21.1 Description:**

- (1) Restore turf areas disturbed from water main installation, including all incidentals necessary to restore the terrace or turf area to grade, such as topsoil and seeding, are included herein.

**704.21.2 Materials:**

- (1) Refer to Article 702 and this section.
- (2) Topsoil: See Article 202 of these Specifications.
- (3) Seeding: See Article 207 of these Specifications.

**704.21.3 Construction:**

- (1) Refer to Article 703 and this section.
- (2) Do not begin placing topsoil until all disturbed areas have been graded to match the original surface grades or to the otherwise specified lines and grades, considering the topsoil depth.
- (3) Place and spread topsoil uniformly to a depth of at least 6-inches, unless specified otherwise.
- (4) Clean topsoil off of sidewalks, paths, curbs, and roadways prior to the end of each working day.
- (5) Protect adjacent stormwater structures during placement of topsoil. The Engineer reserves the right to order the installation of curb and field inlet sediment barriers to be constructed in accordance with Article 210 of these Specifications.
- (6) Water the restoration areas immediately after seeding. Keep the areas moist by watering or sprinkling until the perennial grass seed covering the entire disturbed terrace area has germinated and grown to a minimum height of 2-inches. Reseed any bare patches.
- (7) Place mulch on all seeded areas within 3 days of completing the seeding. Do not mulch during high wind conditions. Maintain the mulched areas and repair any areas damaged by wind, erosion, traffic, or other causes until the turf is firmly established.
- (8) When ordered by the Engineer, dust-proof the patch by sprinkling it with a water and calcium chloride mixture in accordance with Article 107 of these Specifications.

**704.21.4 Method of Measurement:**

- (1) Measured by length in feet, to the nearest half foot, along the trench centerline at the surface.

**704.21.5 Basis of Payment:**

- (1) Paid at the contract unit prices under the following bid items:

ITEM NUMBER	DESCRIPTION	UNIT
70102	TERRACE RESTORATION FOR WATER MAIN	L.F.

- (2) Additional compensation will be at the rate stated in Article 107 for providing any dust proofing.

**704.22 Water Valve Access Structure.**

**Bid Item 70103.**

**704.22.1 Description:**

- (1) Furnish and install a 6-foot (inside diameter) water valve access structure with steps and casting. The work also includes preparing the foundation for the structure and tapping the water main.

**704.22.2 Materials:**

- (1) Refer to Article 702 and this section.
- (2) Adjustment rings and castings: Conform to Articles 503 and 507.
- (3) The water valve access structure has a flat top with an offset opening and a standard access structure frame and non-rocking cover.
- (4) See Standard Detail Drawing 7.07 for additional material details.

**704.22.3 Construction:**

- (1) Construction of concrete valve access structures is to be done in accordance to the requirements Standard Detail Drawings 7.07 and Article 507 of these Specifications.
- (2) Center the water valve access structure over the valve.
- (3) Place clear gravel and stones up to 3-inches as a base for the structure.
- (4) Place an 8-inch or larger concrete block under the valve to provide support.
- (5) Provide appropriate openings in the structure and the support ring so that the structure is not resting on the water main.
- (6) Install a 1-inch tap on each side of the valve.

**704.22.4 Method of Measurement:**

- (1) Measured by each completed unit.

**704.22.5 Basis of Payment:**

- (1) Paid at the contract unit prices under the following bid items:

<b>ITEM NUMBER</b>	<b>DESCRIPTION</b>	<b>UNIT</b>
70103	WATER VALVE ACCESS STRUCTURE	EACH

**704.23 Adjust Water Valve Box.**

**Bid Item 70104.**

**704.23.1 Description:**

- (1) Furnish a new top casting with a lid and adjust all existing water valve boxes within the project limits to a tolerance between 1/4-inch to 1/2-inch below finished grade. If necessary or as required, furnish and replace damaged or non-functioning existing lower valve box sections.

**704.23.2 Materials:**

- (1) Refer to Article 702 and this section.
- (2) Refer to Article 704 – ‘Furnish & Install Water Valve’ and this section.

**704.23.3 Construction:**

- (1) Refer to Article 703 and this section.
- (2) Refer to Article 704 ‘Furnish & Install Water Valve’ and this section.
- (3) Excavate and expose the existing water valve boxes to the depth needed to install a new top casting with a new lid, center the valve box over the operating nut and adjust the valve boxes to finished grade. If the valve operating nut is not exposed due to mud and/or debris, remove the material to expose the operating nut to ensure the valve box is centered and aligned properly.
- (4) Extensions or replacement valve box materials may be required and will be paid as listed below.
- (5) Leave all valve boxes centered over the valve operating nut and free of dirt and debris.

**704.23.4 Method of Measurement:**

- (1) Measured by each completed unit.

**704.23.5 Basis of Payment:**

- (1) Paid at the contract unit prices under the following bid items:

ITEM NUMBER	DESCRIPTION	UNIT
70104	ADJUST WATER VALVE BOX	EACH

- (2) In the event that additional materials are needed during construction, full-payment for furnishing and installing the additional materials will be made as follows:

DESCRIPTION	UNIT	PRICE
TOP CASTING WITH LID	EACH	\$100.00
BOTTOM SECTION	EACH	\$100.00
NO. 6 BASE	EACH	\$100.00
BOX ALIGNMENT DEVICE	EACH	\$150.00
12-INCH EXTENSION	EACH	\$100.00
18-INCH EXTENSION	EACH	\$100.00
24-INCH EXTENSION	EACH	\$100.00

- (2) Adjustment of new valve boxes is incidental to valve box installations and will not be paid.



**704.24 Pipe Plug for Water Main Installation.**

**Bid Item 70105.**

**704.24.1 Description:**

- (1) Furnish and install a concrete mix on each end of abandoned pipes that were removed due to an existing grade conflict during the installation of new water facilities.

**704.24.2 Materials:**

- (1) Refer to Article 702 and this section.
- (2) Concrete mix can be either:
  - 1. A pre-approved bag mix.
  - 2. Pre-mix from a concrete supplier.

**704.24.3 Construction:**

- (1) Refer to Article 703 and this section.
- (2) Excavate and expose the conflicting abandoned pipe.
- (3) Cut out a segment of the pipe that is large enough for clearance of the concrete mix on the open ends, and for the new water main to pass through.
- (4) Using a concrete mix on the open ends of the abandoned pipe, form a tight seal so as not to allow dirt or water to enter the pipe.

**704.24.4 Method of Measurement:**

- (1) Measured as a completed unit for each pipe end plugged.

**704.24.5 Basis of Payment:**

- (1) Paid at the contract unit prices under the following bid items:

ITEM NUMBER	DESCRIPTION	UNIT
70105	PIPE PLUG FOR WATER MAIN INSTALLATION	EACH

## **704.25 Rock Excavation.**

### **Bid Item 70106.**

#### **704.25.1 Description:**

- (1) Rock excavation applies to the removal of hard solid rock in ledges, bedded deposits, unstratified masses, conglomerate deposits or any other material so firmly cemented as to present characteristics of solid rock.
- (2) If determined by the Engineer that such material is so hard or so firmly cemented that it is not practical to excavate and remove such material with a power shovel, it shall be thoroughly and continuously drilled and blasted prior to removal.
- (3) Power shovels, as referred to above:
  1. A modern track mounted power shovel or backhoe.
  2. Not less than  $\frac{3}{4}$ -cubic yard manufacturer's rated capacity.
  3. Have adequate power and good running condition.
  4. Used by an experienced operator.
- (4) Rock excavation also applies to all stone/rock necessary to be removed having a volume of 1-cubic yard (27-cubic feet) or more. Removal of plain or asphalt-bound bases or surface courses of macadam, gravel, or broken stone are not considered rock excavation.

#### **704.25.2 Materials:**

- (1) Refer to Article 702 and this section.
- (2) (Vacant).

#### **704.25.3 Construction:**

- (1) Refer to Article 703 and this section.
- (2) Remove enough rock to provide clearance below and on each side of all pipe, valves and fittings. Clearance requirements:
  1. At least 6-inches for nominal pipe sizes 24-inches or smaller
  2. At least 9-inches for nominal pipe sizes 30-inches or larger.
- (3) The width of rock excavation is limited to the outside diameter of the pipe plus 2-feet.
- (4) Upon completion of the rock excavation, refill that portion of the trench with select fill and mechanically compact the fill material prior to laying the pipe. The pipe is required to have uniform bearing along its entire length and never shall be laid directly on rock.

#### **704.25.4 Method of Measurement:**

- (1) Field-measure and compute the rock excavation volume in cubic yards (neat-line volumes).

Part VII - Water Mains and Service Laterals

- (2) The vertical measurement extends from the surface of the rock to an elevation of 6-inches below the bottom invert of the water main.
- (3) The vertical measurement for valve access structures extends from the surface of the rock to an elevation of 8-inches below the bottom invert of the valve access structure (up to ten 10-foot deep). The measurement extends 12-inches below the bottom invert of the valve access structure if it is over 10-foot deep.
- (4) Horizontal measurements are limited to the outside diameter of the pipe or outside width of the structure, plus two 2-feet.
- (5) Boulders measuring 1/2-cubic yard or more in volume are measured individually. The volume of each boulder computed from average dimensions taken in three directions.
- (6) No measurement of excessive excavation.

**704.25.5 Basis of Payment:**

- (1) Paid at the contract unit prices under the following bid items:

<b>ITEM NUMBER</b>	<b>DESCRIPTION</b>	<b>UNIT</b>
70106	ROCK EXCAVATION	C.Y.

**704.26 Removal of Excess Amounts of Boulders.**

**Bid Item 70107.**

**704.26.1 Description:**

- (1) Boulders are considered to be naturally occurring rocks that have a dimension greater than 12-inches in one or more faces.
- (2) Remove any and all boulders encountered regardless of number.
- (3) When deemed by the Engineer that the amount of boulders encountered on a project is excessive, additional payment will be covered under this item.

**704.26.2 Materials:**

- (1) Refer to Article 702 and this section.
- (2) (Vacant).

**704.26.3 Construction:**

- (1) Refer to Article 703 and this section.
- (2) (Vacant).

**704.26.4 Method of Measurement:**

- (1) Payment for this item must be authorized by the Engineer.
- (2) Boulders under 1-cubic yard in volume are to be measured by truck volume.
- (3) Boulders over 1-cubic yard in volume are to be measured individually. Measure by taking the average dimensions in three directions.

**704.26.5 Basis of Payment:**

- (1) Paid at the contract unit prices under the following bid items:

<b>ITEM NUMBER</b>	<b>DESCRIPTION</b>	<b>UNIT</b>
70107	REMOVAL OF EXCESS AMOUNTS OF BOULDERS	C.Y.

- (2) In the absence of a bid item, a payment of \$6.00 per cubic yard of boulders hauled from the project may be added to the Contract Documents, when authorized by the Engineer.
- (3) Excessively large boulders are considered to be, and paid under, the Rock Excavation Bid Item.

**704.27 Additional Excavation.**

**Bid Item 70108.**

**704.27.1 Description:**

- (1) Refer to Article 703.4 and this section.
- (2) Additional excavation applies to:
  - 1. Additional excavation areas specifically depicted on the Construction Drawings and/or described in the Contract Documents.
  - 2. Additional excavation extending beyond the allowable 2-foot allowance as a result of grade adjustments and/or adjusted excavation requirements ordered by the Engineer.
  - 3. No compensation will be considered for over-excavation done for convenience.
  - 4. Note that additional excavation extending beyond the allowable 1-foot allowance as a result of artificial foundation construction in poor soils ordered by the Engineer is considered to be undercut and shall be paid for under the “Undercut” bid item.

**704.27.2 Materials:**

- (1) Refer to Article 702 and this section.
- (2) (Vacant).

**704.27.3 Construction:**

- (1) Refer to Article 703 and this section.
- (2) (Vacant).

**704.27.4 Method of Measurement:**

- (1) Field-measure and compute the authorized additional excavation volume in cubic yards (neat-line volumes).
- (2) Maximum allowed measured width:
- (3) The outside diameter of the pipe/structure, plus 2-feet, plus the amount necessary for sheeting and bracing.

**704.27.5 Basis of Payment:**

- (1) Paid at the contract unit prices under the following bid items:

ITEM NUMBER	DESCRIPTION	UNIT
70108	ADDITIONAL EXCAVATION	C.Y.

- (2) No payments for over-excavation done for convenience or without the Engineer’s consent.

**704.28 Undercut.**

**Bid Item 70109.**

**704.28.1 Description:**

- (1) Undercut is defined as any work involved in removing unsuitable materials and forming a satisfactory foundation at depths greater than 12-inches below the water main where identified on the drawings and/or specifications, and other areas where the Engineer approves the undercut in writing.
- (2) All work associated with forming a stable and satisfactory foundation at depths of twelve 12-inches or less below the bottom of the pipe is considered incidental and will not be considered as undercut.

**704.28.2 Materials:**

- (1) Refer to Article 702 and this section.
- (2) (Vacant).

**704.28.3 Construction:**

- (1) Refer to Article 703 and this section.
- (2) (Vacant).

**704.28.4 Method of Measurement:**

- (1) Field-measure and compute the undercut volume in cubic yards (neat-line volumes).
- (2) Maximum measured width: The outside diameter of the pipe or outside dimension of the bottom of the structure, plus 2-feet, plus the amount necessary for sheeting and bracing.

**704.28.5 Basis of Payment:**

- (1) Paid at the contract unit prices under the following bid items:

ITEM NUMBER	DESCRIPTION	UNIT
70109	UNDERCUT	C.Y.

**704.29 Adjust Water Service Box.**

**(No Bid Item).**

**704.29.1 Description:**

- (1) Adjust existing water service boxes within the project limits to match the finished grade as shown on the plans or directed by the Engineer.

**704.29.2 Materials:**

- (1) Refer to Article 702 and this section.
- (2) (Vacant).

**704.29.3 Construction:**

- (1) Refer to Article 703 and this section.
- (2) Excavate and expose the existing water service boxes to the depth needed to adjust the valve boxes to finished grade.
- (3) Apply extensions as required.
- (4) Leave all service boxes centered over the curb stop and free of dirt and debris.

**704.29.4 Method of Measurement:**

- (1) Measured by each completed unit.

**704.29.5 Basis of Payment:**

- (1) Paid as follows:

<b>AMOUNT PAID</b>	<b>DESCRIPTION</b>	<b>UNIT</b>
\$100.00	ADJUST WATER SERVICE BOX	EACH

- (2) Adjustments to new service boxes are incidental to their installation, and will not be paid under this item.

**704.30 Furnish and Install Curb Box.**

**(No Bid Item).**

**704.30.1 Description:**

- (1) Provide all labor and materials necessary to install new curb boxes where existing curb boxes are damaged, or otherwise in need of replacement as authorized in writing by the Engineer.

**704.30.2 Materials:**

- (1) Refer to Article 702 and this section.
- (2) (Vacant).

**704.30.3 Construction:**

- (1) Refer to Article 703 and this section.
- (2) Install the curb box vertically over the curb stop so that after the service is backfilled to final grade, a key may be placed on the rod of the curb stop and it may be operated easily.
- (3) Set curb boxes flush with the finished ground elevation.

**704.30.4 Method of Measurement:**

- (1) Measured by each completed unit.

**704.30.5 Basis of Payment:**

**704.30.6** Paid as follows:

<b>AMOUNT PAID</b>	<b>DESCRIPTION</b>	<b>UNIT</b>
\$350.00	FURNISH AND INSTALL CURB BOX	EACH



**704.31 Furnish and Install Curb Stop.**

**(No Bid Item).**

**704.31.1 Description:**

- (1) Provide all labor and material necessary to install new curb stops where existing curb stops are damaged, or otherwise in need of replacement as authorized in writing by the Engineer.

**704.31.2 Materials:**

- (1) Refer to Article 702 and this section.
- (2) (Vacant).

**704.31.3 Construction:**

- (1) Refer to Article 703 and this section.
- (2) Install curb stops on the designated service lateral at a point 8-feet from the property line, unless specified otherwise or ordered by the Engineer.
- (3) Install a 4-inch x 8-inch x 8-inch solid concrete masonry unit, laid flat, in the excavation to provide a firm base for the curb stop.
- (4) Adequately wrap the curb stop with polyethylene wrap to prevent debris from entering or impacting the operability of the curb stop.
- (5) Do not locate curb stops in curb, sidewalk, driveways, or within 5-feet of the bases of trees.

**704.31.4 Method of Measurement:**

- (1) Measured by each completed unit.

**704.31.5 Basis of Payment:**

- (1) Paid as follows:

<b>AMOUNT PAID</b>	<b>DESCRIPTION</b>	<b>UNIT</b>
\$500.00	FURNISH AND INSTALL CURB STOP	EACH

**704.32 Abandon Existing Curb Box.**

**(No Bid Item).**

**704.32.1 Description:**

- (1) Abandon all water service curb boxes within the project limits that are connected to laterals no longer in service, as shown on the plans or directed by the Engineer.

**704.32.2 Materials:**

- (1) Refer to Article 702 and this section.
- (2) (Vacant).

**704.32.3 Construction:**

- (1) Refer to Article 703 and this section.
- (2) Proceed with the work only after the existing water service lateral has been abandoned.
- (3) Remove the top casting to a point three 3-feet below the final elevation.
- (4) Restore the terrace area as necessary.

**704.32.4 Method of Measurement:**

- (1) Measured by each completed unit.

**704.32.5 Basis of Payment:**

- (1) Paid as follows:

<b>AMOUNT PAID</b>	<b>DESCRIPTION</b>	<b>UNIT</b>
\$50.00	ABANDON EXISTING CURB BOX	EACH

- (2) Note that only curb boxes that fall outside of new service excavations will be paid.

## **PART VIII - STANDARD DETAIL DRAWINGS**

---

### **SERIES 1 - EROSION CONTROL**

- 1.01 [SILT FENCE](#)
- 1.02 [EROSION MAT](#)
- 1.03 [TYPICAL INSTALLATIONS OF EROSION BALES](#)
- 1.04 [INLET PROTECTION, TYPE C](#)
- 1.05 [CLEAR STONE BERM FOR EROSION CONTROL](#)
- 1.06 [INLET PROTECTION TYPE D](#)
- 1.07 [CONSTRUCTION ENTRANCE](#)
- 1.08 [STREET CONSTRUCTION ENTRANCE BERM](#)
- 1.09 [SILT SOCK](#)
- 1.10 [STREET CONSTRUCTION STONE BERM](#)
- 1.11 [INLET PROTECTION TYPE D HYBRID](#)

### **SERIES 2 - EARTHWORK**

- 2.01 [STANDARD PLANTING TECHNIQUE FOR TREES IN TURF AREAS](#)
- 2.02 [STANDARD PLANTING TECHNIQUE FOR TREES IN TREE GRATES](#)
- 2.03 [STANDARD PLANTING TECHNIQUE FOR EVERGREENS](#)
- 2.04 [STANDARD PLANTING TECHNIQUE FOR SHRUBS](#)
- 2.05 [STANDARD PRUNING TECHNIQUES FOR DECIDUOUS AND CONIFEROUS TREES AND SHRUBS](#)
- 2.06 [TYPICAL FIELD STONE RETAINING WALL](#)
- 2.07 [WETLAND PLANTING PODS TYPE #1](#)
- 2.08 [WETLAND PLANTING PODS TYPE #2](#)
- 2.09 [RAINGARDEN DETAIL](#)

### **SERIES 3 - CONCRETE AND CONCRETE STRUCTURES**

- 3.01 [STANDARD SPECIAL WATERWAY](#)
- 3.02 [MADISON STANDARD CURB CUT DETAILS](#)
- 3.03 [STANDARD CURB RAMPS TYPES 1 AND 2](#)
- 3.04 [CURB RAMPS GENERAL AND CURB RAMP TYPE 2-A](#)
- 3.05 [CURB & GUTTER DETAIL AT END OF CUL-DE-SAC](#)
- 3.06 [MADISON STANDARD CONCRETE CURB & GUTTER](#)
- 3.07 [MADISON STANDARD CONCRETE CURB & GUTTER](#)
- 3.08 [MADISON STANDARD CONCRETE CURB & GUTTER](#)
- 3.09 [MADISON STANDARD COMMERCIAL DRIVE DETAILS](#)
- 3.10 [LONGITUDINAL JOINTS AND PAVEMENT TIES DETAIL](#)
- 3.11 [DOWELED CONCRETE PAVEMENT DETAIL](#)
- 3.12 [MADISON STANDARD SECTION CORNER MONUMENT DETAIL](#)
- 3.13 [CONCRETE MOUNTABLE MEDIAN ISLAND NOSE DETAILS](#)
- 3.14 [BIKE RAMP CURB CUT DETAIL](#)

### **SERIES 4 - PAVEMENTS**

- 4.01 [TYPICAL SECTION 32' STREET](#)
- 4.02 [TYPICAL SECTION VARIOUS WIDTH STREETS](#)
- 4.03 [TYPICAL SECTION BOULEVARD STREET](#)
- 4.04 [TYPICAL SECTION TEMPORARY STREET](#)
- 4.05 [TYPICAL SECTION WITH UNDERDRAINS](#)
- 4.06 [PAVEMENT DESIGN CRITERIA](#)
- 4.07 [TYPICAL ALLEY WITH CURB & GUTTER](#)
- 4.08 [TYPICAL SECTION BIKE PATH](#)

- 4.09 [GRINDING DETAIL](#)
- 4.10 [CONCRETE SPEED HUMP](#)
- 4.11 [CONCRETE SPEED HUMP RAISED GUTTER](#)

## **SERIES 5 - SEWER AND SEWER STRUCTURES**

- 5.1 GENERAL
- 5.1.1 [MANDREL DETAIL](#)
- 5.1.2 [RCBC REPAIR TYPE I & TYPE II](#)
- 5.1.3 [TYPICAL SECTION SAS ACCESS ROAD TEMPORARY](#)
- 5.1.4 [TYPICAL SECTION SAS ACCESS ROAD PERMANENT](#)
- 5.2 TRENCH EXCAVATION, BEDDING AND BACKFILL
- 5.2.1 [STORM AND SANITARY SEWER BEDDINGS](#)
- 5.2.1A [HDPE BEDDING AND BACKFILL](#)
- 5.2.2 [TYPICAL TRENCH COMPACTION](#)
- 5.2.3 [TYPICAL TRENCH COMPACTION \(GREENWAY/PARK\)](#)
- 5.2.4 [TYPICAL PAVEMENT PATCH SECTIONS](#)
- 5.3 SANITARY SEWER PIPES
- 5.3.1 [RISER DETAIL](#)
- 5.3.2 [LOCATION OF SANITARY LATERALS](#)
- 5.3.3 [COUPLING DETAILS](#)
- 5.4 STORM SEWER PIPES, APRON ENDWALLS AND OTHER STORM WATER CHANNELS
- 5.4.1 [APRON ENDWALLS FOR PIPES AND PIPE ARCHES](#)
- 5.4.2 [MULTIPLE RCP AE](#)
- 5.4.3 [MULTIPLE HERCP AE](#)
- 5.4.4 [RIPRAP AT APRON ENDWALLS](#)
- 5.4.5 [CONCRETE COLLAR](#)
- 5.4.6 [CONCRETE PIPE JOINT TIES](#)
- 5.4.7 [DRAINAGE FLUME DETAIL](#)
- 5.4.8 [DRAINAGE FLUME DETAIL](#)
- 5.4.9 [SIDEWALK FLUME DETAIL](#)
- 5.4.10 [CURB TO DITCH TRANSITION ASPHALT FLUME](#)
- 5.4.11 [TYPICAL GREENWAY SECTION \(GRASSED-FLOWLINE\)](#)
- 5.4.12 [TYPICAL GREENWAY SECTION \(STABILIZED-FLOWLINE\)](#)
- 5.4.13 [BIO-RETENTION DETAIL](#)
- 5.5 BOX CULVERTS AND WINGWALLS
- 5.5.1 [BOX CULVERT WINGWALL](#)
- 5.5.2 [RIPRAP AT BOX CULVERT WINGWALLS](#)
- 5.6 STORM SEWER GATES
- 5.6.1 [RCP AE GATE](#)
- 5.6.2 [BOX CULVERT INLET GATE \(UPSTREAM\)](#)
- 5.6.3 [BOX CULVERT OUTLET GATE \(DOWNSTREAM\)](#)
- 5.6.4 [STANDARD BASIN OUTLET STRUCTURE](#)
- 5.6.5 [STANDARD-BASIN OUTLET PIPE GATE DETAIL](#)
- 5.7 SEWER STRUCTURES
- 5.7.1 [SANITARY SEWER CAST-IN-PLACE SAS](#)
- 5.7.2 [SANITARY SEWER PRECAST SAS](#)
- 5.7.3 [STORM SEWER FIELD POURED SAS AND CATCHBASINS](#)
- 5.7.4 [STORM SEWER 6'X6' CATCHBASIN](#)
- 5.7.5 [STORM SEWER PRECAST SAS \(THROUGH SECTION VIEW\)](#)
- 5.7.6 [STORM SEWER PRECAST SAS \(TOP VIEW\)](#)
- 5.7.7 [TYPE "H" INLET](#)
- 5.7.8 [SADDLED INLET TYPE I](#)
- 5.7.9 [SADDLED INLET TYPE II](#)
- 5.7.9A [STORM SEWER FIELD POURED SADDLED SAS](#)
- 5.7.10 [STORM SEWER PRECAST SADDLED INLET](#)
- 5.7.10A [STORM SEWER PRECAST SADDLED SAS](#)

- 5.7.11 [RECONSTRUCT TUB INLET](#)
- 5.7.12 [TERRACE INLET TYPE 1](#)
- 5.7.12A [TERRACE INLET TYPE 2](#)
- 5.7.12B [TERRACE INLET TYPE 3](#)
- 5.7.12C [TERRACE INLET TYPE 4](#)
- 5.7.12D [TERRACE INLET TYPE 5](#)
- 5.7.13 [CURB OUTLET STRUCTURE](#)
- 5.7.14 [UNDERDRAIN](#)
- 5.7.15 [SAS CHIMNEY AND CASTING](#)
- 5.7.16 [SAS FRAME AND COVER](#)
- 5.7.17 [SAS INTERNAL CHIMNEY SEAL](#)
- 5.7.18 [R-3067 FRAME](#)
- 5.7.20 [R-3067 TYPE R GRATE](#)
- 5.7.21 [R-3067 TYPE V GRATE \(VANE\)](#)
- 5.7.22 [R-3067 EL CURB BOX](#)
- 5.7.24 [R-3067 CDS CURB BOX](#)
- 5.7.25 [TYPE "S" INLET & R-3281 CASTING](#)
- 5.7.26 [CONSTRUCTION STORM STAKING LAYOUT](#)
- 5.7.27 [H INLET LOCATIONS IN DIFFERENT CURB TYPES](#)
- 5.7.28 [INLET IN TYPE "H" CURB AND GUTTER WITH CONCRETE PAVEMENT](#)
- 5.7.29 [INLET CASTING OFFSET CRITERIA FOR H INLETS](#)
- 5.7.30 [INSIDE DROP FOR SANITARY LATERAL](#)
- 5.7.31 [FLEXIBLE PIPE TO SAS CONNECTOR](#)
- 5.7.32 [STORM SEWER TAP DETAIL](#)
- 5.7.33 [H INLET ALLEY CURB](#)
- 5.7.34 [DITCH INLET STRUCTURE](#)
- 5.7.35 [TERRACE FLUME](#)
- 5.7.36 [SIDEWALK DRAIN](#)
- 5.7.37 [RIBBON CURB CASTING R-3382](#)
- 5.7.38 [CURB HEAD PLATE FOR DRIVEWAY R-3067-7000](#)
- 5.7.39 [SCREEN TREATMENT DEVICE](#)
- 5.7.39A [SCREEN TREATMENT DEVICE](#)
- 5.8 [UTILITY CROSSINGS](#)
- 5.8.1 [CONCRETE SUPPORTS](#)
- 5.8.2 [REINFORCED CONCRETE BEAM SUPPORT](#)

## **SERIES 6 - TRAFFIC ENGINEERING**

- 6.01 [TYPICAL ELEVATIONS FOR BASES](#)
- 6.02 [TYPICAL PLAN VIEW OF DUCT INSTALLATION & DUCT IMPRINT LOCATION](#)
- 6.03 [DUCT TERMINATION DETAIL](#)
- 6.04 [LOOP LEAD DUCT DETAIL](#)
- 6.05 [CONCRETE POLE BURIAL DETAIL](#)
- 6.06 [POLE MOUNTED STREET LIGHT CONTROL PANEL](#)
- 6.07 [PEDESTAL MOUNTED STREET LIGHT CONTROL PANEL](#)
- 6.08 [120V STREET LIGHT CONTROL PANEL ELECTRICAL SERVICE DETAIL](#)
- 6.09 [CONDUIT PLACEMENT DETAILS FOR COMMERCIAL DRIVE APPROACH](#)
- 6.10 [TYPE "M" AND "P" CONTROLLER BASE DETAIL](#)
- 6.11 [TYPE "G" BASE DETAIL](#)
- 6.12 [LB-1 DETAIL](#)
- 6.13 [LB-2 DETAIL](#)
- 6.14 [LB-3 DETAIL](#)
- 6.15 [LB-4 DETAIL](#)
- 6.17 [LB-6 DETAIL](#)
- 6.18 [LB-7 BASE DETAIL](#)
- 6.19 [LB-8 BASE DETAIL](#)
- 6.20 [OFFSET BASE DETAIL](#)

- 6.21 [TYPICAL DETAIL FOR AUGERING A HOLE\(S\) IN EXISTING BASE FOR DUCT ENTRANCE](#)
- 6.22 [TYPE I HANDHOLE DETAIL](#)
- 6.23 [TYPE II HANDHOLE DETAIL](#)
- 6.24 [TYPE III HANDHOLE DETAIL](#)
- 6.25 [TYPE IV HANDHOLE DETAIL](#)
- 6.26 [TYPE V HANDHOLE DETAIL](#)
- 6.27 [ELECTRICAL UTILITY ACCESS STRUCTURE DETAIL](#)
- 6.28 [ELECTRICAL CONDUIT BOX-OUT DETAIL](#)
- 6.29 [STREET BARRICADE DETAILS](#)
- 6.30 [SUPPLEMENTAL TRAFFIC CONTROLS FOR BIKEWAY CLOSURES](#)
- 6.31 [BARRICADES AND SIGNS FOR MAINLINE CLOSURES](#)
- 6.32 [BARRICADES AND SIGNS FOR SIDEROAD CLOSURES](#)
- 6.33 [TRAFFIC CONTROL, SINGLE LANE CLOSURE NON-FREEWAY/EXPRESSWAY](#)
- 6.34 [TRAFFIC CONTROL, INTERSECTION WITHIN SINGLE LANE CLOSURE](#)
- 6.35 [TRAFFIC CONTROL FOR LANE CLOSURE \(SUITABLE FOR MOVING OPERATIONS\)](#)
- 6.36 [TRAFFIC CONTROL, SIDEWALK CLOSURE](#)
- 6.37 [PAVEMENT MARKING DETAILS, PAGE 1](#)
- 6.38 [PAVEMENT MARKING DETAILS, PAGE 2](#)
- 6.39 [PAVEMENT MARKING DETAILS, PAGE 3](#)
- 6.40 [PAVEMENT MARKING DETAILS, PAGE 4](#)
- 6.41 [PIPE INSERT IN CONCRETE FOR SIGNING](#)
- 6.42 [PRECAST SIGN POST BASE DETAILS](#)
- 6.43 [SIGN POST DETAIL](#)
- 6.44 [ALTERNATE BUSINESS ACCESS SIGN](#)
- 6.45 [LB-9 BASE DETAIL](#)
- 6.46 [TYPICAL CONDUIT INSTALLATION PARALLEL TO CURB AND GUTTER](#)
- 6.47 [MULTISPACE PARKING METER BASE DETAIL](#)

## **SERIES 7 - WATER MAINS AND SERVICE LATERALS**

- 7.01 [SERVICE INSTALLATION - PRIVATE CONTRACT](#)
- 7.02 [STANDARD THREADED RODDING](#)
- 7.03 [STANDARD THRUST BLOCKING](#)
- 7.03A [STANDARD CONCRETE BLOCK THRUST RESTRAINT](#)
- 7.03B [GRAVITY BLOCK THRUST RESTRAINT FOR VERTICAL DOWN BENDS](#)
- 7.03C [ROD & CONCRETE BLOCK THRUST RESTRAINT FOR VERTICAL BENDS](#)
- 7.04 [TYPICAL HYDRANT INSTALLATION](#)
- 7.05 [TYPICAL STYROFOAM INSTALLATION](#)
- 7.06A [WATER METER PIT CONSTRUCTION](#)
- 7.06B [WATER METER PIT DIMENSIONS](#)
- 7.06C [WATER METER PIT CONSTRUCTION NOTES](#)
- 7.07 [WATER MAIN VALVE ACCESS STRUCTURE](#)
- 7.08 [STANDARD HDPE PIPE RESTRAINTS](#)
- 7.09 [CASING SPACERS](#)
- 7.10 [JOINT RESTRAINT LENGTHS FOR VERTICAL BENDS](#)
- 7.11 [TYPICAL WATER PIPE TRENCH](#)
- 7.12 [OFFSETTING EXISTING WATER MAIN UNDER UTILITY CONFLICTS](#)

## STANDARD BID ITEM NUMBERS

ITEM NUMBER	TYPE OF WORK	UNIT
10701	TRAFFIC CONTROL	LUMP SUM
10702	TRAFFIC CONTROL FOR STORM SEWER INSTALLATION	LUMP SUM
10703	TRAFFIC CONTROL FOR WATER MAIN INSTALLATION	LUMP SUM
10704	TRAFFIC CONTROL FOR SANITARY SEWER INSTALLATION	LUMP SUM
10711	TYPE III BARRICADE	EACH
10720	TRAFFIC CONTROL SIGN - PORTABLE ARROW BOARD	DAYS
10721	TRAFFIC CONTROL SIGN - PORTABLE CHANGEABLE MESSAGE	DAYS
10725	ALTERNATE BUSINESS ACCESS SIGN	DAYS
10750	RESET MONUMENT	EACH
10790	RAILROAD INSURANCE	LUMP SUM
10801	ROOT CUTTING – CURB & GUTTER	L.F.
10802	ROOT CUTTING – SIDEWALK	L.F.
10901	FIELD OFFICE	LUMP SUM
10911	MOBILIZATION	LUMP SUM
10912	MOBILIZATION FOR STORM SEWER INSTALLATION	LUMP SUM
10913	MOBILIZATION FOR WATER MAIN INSTALLATION	LUMP SUM
10914	MOBILIZATION FOR SANITARY SEWER INSTALLATION	LUMP SUM
20101	EXCAVATION CUT	C.Y.
20102	ROCK EXCAVATION	C.Y.
20109	FINISH GRADING	LUMP SUM
20130	UNDERDRAIN	L.F.
20140	GEOTEXTILE FABRIC TYPE SAS NON WOVEN	S.Y.
20201	FILL BORROW	TON
20202	FILL BORROW	C.Y.
20204	SELECT FILL	TON
20205	SELECT FILL	C.Y.
20207	SELECT FILL SAND	TON
20208	SELECT FILL SAND	C.Y.
20210	SELECT FILL GRAVEL	TON
20211	SELECT FILL GRAVEL	C.Y.
20214	SELECT FILL CRUSHED STONE	TON
20215	SELECT FILL CRUSHED CONCRETE	TON
20216	SALVABLE CRUSHED STONE	TON
20217	CLEAR STONE	TON
20218	CRUSHED STONE	TON
20219	BREAKER RUN	TON
20221	TOPSOIL	S.Y.
20225	LIGHT RIPRAP	C.Y.
20226	LIGHT RIPRAP	TON
20227	MEDIUM RIPRAP	C.Y.
20228	MEDIUM RIPRAP	TON
20229	HEAVY RIPRAP	C.Y.
20230	HEAVY RIPRAP	TON
20231	EXTRA HEAVY RIPRAP	C.Y.
20232	EXTRA HEAVY RIPRAP	TON
20233	RIPRAP FILTER FABRIC, TYPE HR	S.Y.

## STANDARD BID ITEM NUMBERS

ITEM NUMBER	TYPE OF WORK	UNIT
20301	SAWCUT CONCRETE PAVEMENT, FULL DEPTH	L.F.
20302	SAWCUT CONCRETE FULL DEPTH	L.F.
20303	SAWCUT BITUMINOUS PAVEMENT	L.F.
20311	REMOVE SEWER ACCESS STRUCTURE	EACH
20312	REMOVE CATCHBASIN	EACH
20313	REMOVE INLET	EACH
20314	REMOVE PIPE	L.F.
20321	REMOVE CONCRETE PAVEMENT	S.Y.
20322	REMOVE CONCRETE CURB & GUTTER	L.F.
20323	REMOVE CONCRETE SIDEWALK & DRIVE	S.F.
20324	REMOVE CONCRETE STEPS	S.F.
20325	REMOVE GUARD RAIL	L.F.
20326	REMOVE FENCE	L.F.
20327	REMOVE TREE GRATE	EACH
20331	ABANDON SEWER ACCESS STRUCTURE	EACH
20332	ABANDON CATCHBASIN	EACH
20333	ABANDON INLET	EACH
20335	ABANDON SEWER PIPE WITH SLURRY	C.Y.
20336	PIPE PLUG	EACH
20401	CLEARING	I.D.
20402	CLEARING	STA.
20403	GRUBBING	I.D.
20404	GRUBBING	STA.
20501	ADJUST SEWER ACCESS STRUCTURE	EACH
20502	ADJUST CATCHBASIN	EACH
20503	ADJUST INLET	EACH
20504	ADJUST VALVE CASTING	EACH
20505	ADJUST MONUMENT	EACH
20506	ADJUST SEWER ACCESS STRUCTURE CASTING	EACH
20601	OBLITERATE STREET	STA.
20701	TERRACE SEEDING	S.Y.
20703	TEMPORARY SEEDING	S.Y.
20704	INFILTRATION SEEDING	S.Y.
20705	DETENTION BASIN SEEDING	S.Y.
20706	TALL GRASS PRAIRIE SEEDING	S.Y.
20711	TRENCH RESTORATION 4 INCH TOPSOIL, SEED, FERTILIZE AND MULCH	T.F.
20801	SODDING	S.Y.
20850	SOD DROUGHT WATERING	EACH
20970	TREES, SHRUBS, PERENNIALS AND GRASSES DROUGHT WATERING	EACH
21001	EROSION CONTROL PLAN & IMPLEMENTATION	LUMP SUM
21002	EROSION CONTROL INSPECTION	EACH
21011	CONSTRUCTION ENTRANCE	EACH
21012	STREET CONSTRUCTION ENTRANCE BERM	EACH
21013	STREET SWEEPING	LUMP SUM
21014	CLEAR STONE BERM (DITCH CHECK)	EACH
21015	STREET CONSTRUCTION STONE BERM	EACH



## STANDARD BID ITEM NUMBERS

ITEM NUMBER	TYPE OF WORK	UNIT
21017	SILT SOCK (8 INCH) - COMPLETE	LF
21018	SILT SOCK (8 INCH) - PROVIDE, INSTALL & MAINTAIN	LF
21019	SILT SOCK (8 INCH) - REMOVE & RESTORE	LF
21021	SILT FENCE - COMPLETE	L.F.
21022	SILT FENCE - PROVIDE, INSTALL & MAINTAIN	L.F.
21023	SILT FENCE - REMOVE & RESTORE	L.F.
21024	SILT SOCK (12 INCH) - COMPLETE	L.F.
21025	SILT SOCK (12 INCH) - PROVIDE, INSTALL & MAINTAIN	L.F.
21026	SILT SOCK (12 INCH) - REMOVE & RESTORE	L.F.
21027	EROSION BALES - COMPLETE	L.F.
21028	EROSION BALES - PROVIDE, INSTALL & MAINTAIN	L.F.
21029	EROSION BALES - REMOVE & RESTORE	L.F.
21031	INLET PROTECTION, TYPE C - COMPLETE	EACH
21032	INLET PROTECTION, TYPE C - PROVIDE & INSTALL	EACH
21033	INLET PROTECTION, TYPE C - MAINTAIN	EACH
21034	INLET PROTECTION, TYPE C - REMOVE	EACH
21035	INLET PROTECTION, TYPE C MODIFIED - COMPLETE	EACH
21036	INLET PROTECTION, TYPE C MODIFIED - PROVIDE & INSTALL	EACH
21037	INLET PROTECTION, TYPE C MODIFIED - MAINTAIN	EACH
21038	INLET PROTECTION, TYPE C MODIFIED - REMOVE	EACH
21041	INLET PROTECTION, TYPE D - COMPLETE	EACH
21042	INLET PROTECTION, TYPE D - PROVIDE & INSTALL	EACH
21043	INLET PROTECTION, TYPE D - MAINTAIN	EACH
21044	INLET PROTECTION, TYPE D - REMOVE	EACH
21045	INLET PROTECTION, TYPE D MODIFIED - COMPLETE	EACH
21046	INLET PROTECTION, TYPE D MODIFIED - PROVIDE & INSTALL	EACH
21047	INLET PROTECTION, TYPE D MODIFIED - MAINTAIN	EACH
21048	INLET PROTECTION, TYPE D MODIFIED - REMOVE	EACH
21051	CLEAN SUMP	EACH
21052	POLYMER STABILIZATION	S.Y.
21055	INLET PROTECTION, TYPE D HYBRID - COMPLETE	EACH
21056	INLET PROTECTION, TYPE D HYBRID - PROVIDE & INSTALL	EACH
21057	INLET PROTECTION, TYPE D HYBRID - MAINTAIN	EACH
21058	INLET PROTECTION, TYPE D HYBRID - REMOVE	EACH
21061	EROSION MATTING, CLASS I, URBAN TYPE A	S.Y.
21062	EROSION MATTING, CLASS I, URBAN TYPE B	S.Y.
21063	EROSION MATTING, CLASS I, TYPE A - ORGANIC	S.Y.
21064	EROSION MATTING, CLASS I, TYPE B - ORGANIC	S.Y.
21071	EROSION MATTING, CLASS II, TYPE A - ORGANIC	S.Y.
21073	EROSION MATTING, CLASS II, TYPE C - ORGANIC	S.Y.
21081	EROSION MATTING, CLASS III, TYPE A	S.Y.
21082	EROSION MATTING, CLASS III, TYPE B	S.Y.
21083	EROSION MATTING, CLASS III, TYPE C	S.Y.
21084	EROSION MATTING, CLASS III, TYPE D	S.Y.
21091	TERRACE RESTORATION	T.F.
21092	TERRACE RESTORATION	S.Y.
21110	TERRACE RAIN GARDEN	S.F.
21301	REMOVE AND REPLACE MAILBOX	EACH
30101	#4 EPOXY COATED PAVEMENT TIE	EACH
30102	#5 EPOXY COATED PAVEMENT TIE	EACH
30103	#6 EPOXY COATED PAVEMENT TIE	EACH
30104	#7 EPOXY COATED PAVEMENT TIE	EACH

## STANDARD BID ITEM NUMBERS

ITEM NUMBER	TYPE OF WORK	UNIT
30105	#8 EPOXY COATED PAVEMENT TIE	EACH
30106	#9 EPOXY COATED PAVEMENT TIE	EACH
30107	#10 EPOXY COATED PAVEMENT TIE	EACH
30108	#11 EPOXY COATED PAVEMENT TIE	EACH
30109	#12 EPOXY COATED PAVEMENT TIE	EACH
30111	1 INCH EPOXY COATED DOWEL BAR	EACH
30112	1 1/8 INCH EPOXY COATED DOWEL BAR	EACH
30113	1 1/4 INCH EPOXY COATED DOWEL BAR	EACH
30114	1 3/8 INCH EPOXY COATED DOWEL BAR	EACH
30115	1 1/2 INCH EPOXY COATED DOWEL BAR	EACH
30121	EPOXY COATED BAR STEEL REINFORCING	LBS.
30122	EPOXY COATED BAR STEEL REINFORCING	L.F.
30131	COLD WEATHER PROTECTION OF CONCRETE SIDEWALK & DRIVE (POLYETHYLENE)	L.F.
30132	COLD WEATHER PROTECTION OF CONCRETE CURB & GUTTER (POLYETHYLENE)	L.F.
30133	COLD WEATHER PROTECTION OF CONCRETE SIDEWALK & DRIVE (STRAW)	L.F.
30134	COLD WEATHER PROTECTION OF CONCRETE CURB & GUTTER (STRAW)	L.F.
30141	TYPE A SLURRY	C.Y.
30142	TYPE B SLURRY	C.Y.
30201	TYPE "A" CONCRETE CURB & GUTTER	L.F.
30202	TYPE "B" CONCRETE CURB & GUTTER	L.F.
30203	TYPE "X" CONCRETE CURB & GUTTER	L.F.
30204	TYPE "D" CONCRETE CURB & GUTTER	L.F.
30205	TYPE "E" CONCRETE CURB & GUTTER	L.F.
30206	TYPE "G" CONCRETE CURB & GUTTER	L.F.
30207	TYPE "H" CONCRETE CURB & GUTTER	L.F.
30208	HAND FORMED CONCRETE CURB & GUTTER (TREE LOCATIONS)	L.F.
30209	SPECIAL WATERWAY	S.F.
30210	ALLEY GUTTER	L.F.
30211	TRAFFIC CIRCLE MOUNTABLE CONCRETE CURB & GUTTER	L.F.
30301	5 INCH CONCRETE SIDEWALK	S.F.
30302	7 INCH CONCRETE SIDEWALK & DRIVE	S.F.
30303	COMMERCIAL DRIVE OPENING	EACH
30311	CONCRETE MOUNTABLE MEDIAN ISLAND NOSE	S.F.
30313	CONCRETE STEPS	S.F.
30330	PROFILE SAWCUT	L.F.
30340	CURB RAMP DETECTABLE WARNING FIELDS	S.F.
30341	TREE GRATE 4' X 6' (INCLUDING FRAME)	EACH
30342	TREE GRATE 4' X 8' (INCLUDING FRAME)	EACH
30343	TREE GRATE 5' X 5' (INCLUDING FRAME)	EACH
30344	TREE GRATE 4' X 12' (INCLUDING FRAME)	EACH
30345	TREE GRATE 5' DIAMETER CIRCLE (INCLUDING FRAME)	EACH
30450	CONCRETE RETAINING WALL	S.F.
30451	BOULDER RETAINING WALL	S.F.
30452	TIMBER RETAINING WALL	S.F.
30453	SPLIT BLOCK RETAINING WALL	S.F.
30454	LANNON STONE RETAINING WALL	S.F.

## STANDARD BID ITEM NUMBERS

ITEM NUMBER	TYPE OF WORK	UNIT
30501	REMOVE AND REPLACE 5 INCH CONCRETE SIDEWALK – SIDEWALK REPLACEMENT PROGRAM	S.F.
30502	REMOVE AND REPLACE 7 INCH CONCRETE SIDEWALK & DRIVE – SIDEWALK REPLACEMENT PROGRAM	S.F.
30503	REMOVE AND REPLACE CONCRETE STEPS – SIDEWALK REPLACEMENT	S.F.
30504	REMOVE EXISTING ASPHALT SIDEWALK AND DRIVEWAY - SIDEWALK REPLACEMENT PROGRAM	S.F.
30505	REMOVE AND REPLACE CONCRETE CURB & GUTTER - SIDEWALK REPLACEMENT PROGRAM	L.F.
30506	RESET BRICK PAVERS - SIDEWALK REPLACEMENT PROGRAM	S.F.
30601	HORIZONTAL SAWCUT CONCRETE SIDEWALKS, DRIVEWAYS, TRAFFIC ISLANDS	Inch-Feet
40101	CRUSHED AGGREGATE BASE COURSE, GRADATION NO. 1	TON
40102	CRUSHED AGGREGATE BASE COURSE, GRADATION NO. 2 OR NO. 3	TON
40103	CRUSHED AGGREGATE BASE COURSE, GRADATION NO. 4	TON
40104	CRUSHED AGGREGATE BASE COURSE, GRADATION NO. 5 (BREAKER RUN)	TON
40201	HMA PAVEMENT TYPE E-0.3	TON
40202	HMA PAVEMENT TYPE E-1	TON
40203	HMA PAVEMENT TYPE E-3	TON
40204	HMA PAVEMENT TYPE E-10	TON
40205	HMA PAVEMENT TYPE SMA	TON
40211	TACK COAT	GAL.
40212	SEAL COAT	GAL.
40221	MACHINE LAID ASPHALT CURB	L.F.
40231	ASPHALT DRIVE & TERRACE	S.Y.
40232	ASPHALT DRIVE & TERRACE	TON
40235	ASPHALT WALK & BIKEPATH	S.Y.
40236	ASPHALT WALK & BIKEPATH	TON
40251	ASPHALT MATERIAL FOR CURB FRONT FILL	L.F.
40301	FULL WIDTH GRINDING	S.Y.
40302	PAVEMENT JOINT GRINDING	L.F.
40303	WEDGE CUT GRINDING ASPHALT	S.Y.
40304	WEDGE CUT GRINDING CONCRETE	SY
40308	RAMPING SAS	EACH
40311	PULVERIZE AND SHAPE	S.Y.
40321	UNDERCUT	S.Y.
40332	BASE PATCH GRINDING, METHOD 2	S.Y.
40333	BASE PATCH GRINDING, METHOD 3	S.Y.
40335	BASE PATCH GRINDING, METHOD 5	S.Y.
40351	ASPHALT BASE PATCHING, 3-1/2 INCH	S.Y.
40352	ASPHALT BASE PATCHING, 5 - 8 INCH	S.Y.
40353	ASPHALT BASE PATCHING, 8 - 10 INCH	S.Y.
40534	ASPHALT BASE PATCHING, OVER 10 INCHES	S.Y.
40361	SAS ADJUSTING RING	EACH
40362	ADJUST ACCESS STRUCTURE CASTING - RESURFACING	EACH
40363	ADJUST CATCHBASIN CASTING - RESURFACING	EACH
40364	ADJUST INLET CASTING, TYPE "H" - RESURFACING	EACH
40365	ADJUST INLET CASTING, "TUB" TYPE - RESURFACING	EACH
40366	REBUILD INLET - RESURFACING	EACH

## STANDARD BID ITEM NUMBERS

ITEM NUMBER	TYPE OF WORK	UNIT
40367	ADJUST VALVE CASTING, METHOD #1 - RESURFACING	EACH
40368	ADJUST VALVE CASTING, METHOD #2 - RESURFACING	EACH
40369	INSTALL ADJUSTABLE VALVE BOX RISER	EACH
40370	ADJUST MONUMENT CASTING - RESURFACING	EACH
40371	REBUILD ACCESS STRUCTURE TOP - RESURFACING	EACH
40381	REMOVE AND REPLACE CONCRETE CURB & GUTTER, MACHINE PLACED MORE THAN 100 CONTINUOUS FEET - RESURFACING	LF
40382	REMOVE AND REPLACE CONCRETE CURB & GUTTER, HAND PLACED -	L.F.
40383	REMOVE AND REPLACE CONCRETE CURB & GUTTER, MACHINE PLACED, TYPE 'D' OR 'G' - RESURFACING	L.F.
40391	REMOVE AND REPLACE 5 INCH CONCRETE SIDEWALK - RESURFACING	S.F.
40392	REMOVE AND REPLACE 7 INCH CONCRETE SIDEWALK AND DRIVE - RESURFACING	S.F.
40393	CRUSHED STONE BASE COURSE - RESURFACING	TON
40394	REMOVE ASPHALT SURFACE - RESURFACING	S.Y.
40395	REMOVE CONCRETE UTILITY PATCH	L.F.
40401	8 INCH CONCRETE PAVEMENT	S.Y.
40402	9 INCH CONCRETE PAVEMENT	S.Y.
40403	10 INCH CONCRETE PAVEMENT	S.Y.
40404	11 INCH CONCRETE PAVEMENT	S.Y.
40405	12 INCH CONCRETE PAVEMENT	S.Y.
40410	CONCRETE SPEED HUMP	S.Y.
40411	CONCRETE PAVEMENT RECONSTRUCTION	S.Y.
40501	INFRARED SEAMLESS PATCHING	S.F.
40601	PAVEMENT CRACK SEALING	L.S.
40602	PAVEMENT CRACK SEALING	L.F.
40701	SPRAY PATCHING	S.F.
40801	CHIP SEAL	LUMP SUM
50101	RCBC ROOF REPAIR, TYPE I	EACH
50102	RCBC ROOF REPAIR, TYPE II	EACH
50103	RECONSTRUCT BENCH AND FLOWLINE(S)	EACH
50104	REBUILD BENCH AND FLOWLINE(S)	EACH
50201	ROCK EXCAVATION	C.Y.
50202	TYPE II DEWATERING	LUMP SUM
50211	SELECT BACKFILL FOR STORM SEWER	T.F.
50212	SELECT BACKFILL FOR SANITARY SEWER	T.F.
50213	ADDITIONAL FILL	C.Y.
50221	UTILITY TRENCH PATCH TYPE I	T.F.
50222	UTILITY TRENCH PATCH TYPE I	S.Y.
50223	UTILITY TRENCH PATCH TYPE II	T.F.
50224	UTILITY TRENCH PATCH TYPE II	S.Y.
50225	UTILITY TRENCH PATCH TYPE III	T.F.
50226	UTILITY TRENCH PATCH TYPE III	S.Y.
50227	UTILITY TRENCH PATCH TYPE IV	T.F.
50228	UTILITY TRENCH PATCH TYPE IV	S.Y.
50229	UTILITY TRENCH PATCH TEMPORARY	T.F.
50230	UTILITY TRENCH PATCH TEMPORARY	S.Y.
50301	8 INCH PVC SANITARY SEWER PIPE	L.F.
50302	10 INCH PVC SANITARY SEWER PIPE	L.F.
50303	12 INCH PVC SANITARY SEWER PIPE	L.F.

## STANDARD BID ITEM NUMBERS

ITEM NUMBER	TYPE OF WORK	UNIT
50304	15 INCH PVC SANITARY SEWER PIPE	L.F.
50305	18 INCH PVC SANITARY SEWER PIPE	L.F.
50306	21 INCH PVC SANITARY SEWER PIPE	L.F.
50307	24 INCH PVC SANITARY SEWER PIPE	L.F.
50311	8 INCH CW PVC SANITARY SEWER PIPE	L.F.
50312	10 INCH CW PVC SANITARY SEWER PIPE	L.F.
50313	12 INCH CW PVC SANITARY SEWER PIPE	L.F.
50314	15 INCH CW PVC SANITARY SEWER PIPE	L.F.
50315	18 INCH CW PVC SANITARY SEWER PIPE	L.F.
50316	21 INCH CW PVC SANITARY SEWER PIPE	L.F.
50317	24 INCH CW PVC SANITARY SEWER PIPE	L.F.
50321	8 INCH PVC PRESSURE SANITARY SEWER PIPE	L.F.
50322	10 INCH PVC PRESSURE SANITARY SEWER PIPE	L.F.
50323	12 INCH PVC PRESSURE SANITARY SEWER PIPE	L.F.
50324	15 INCH PVC PRESSURE SANITARY SEWER PIPE	L.F.
50325	18 INCH PVC PRESSURE SANITARY SEWER PIPE	L.F.
50326	21 INCH PVC PRESSURE SANITARY SEWER PIPE	L.F.
50327	24 INCH PVC PRESSURE SANITARY SEWER PIPE	L.F.
50331	8 INCH RCP SANITARY SEWER PIPE	L.F.
50332	10 INCH RCP SANITARY SEWER PIPE	L.F.
50333	12 INCH RCP SANITARY SEWER PIPE	L.F.
50334	15 INCH RCP SANITARY SEWER PIPE	L.F.
50335	18 INCH RCP SANITARY SEWER PIPE	L.F.
50336	21 INCH RCP SANITARY SEWER PIPE	L.F.
50337	24 INCH RCP SANITARY SEWER PIPE	L.F.
50351	4 INCH SANITARY SEWER LATERAL	L.F.
50352	6 INCH SANITARY SEWER LATERAL	L.F.
50353	SANITARY SEWER LATERAL	L.F.
50354	RECONNECT	EACH
50355	SANITARY SEWER RISER	V.F.
50357	COMPRESSION COUPLING	EACH
50361	WASTEWATER CONTROL	LUMP SUM
50362	12 INCH CWPP SANITARY SEWER PIPE	L.F.
50363	15 INCH CWPP SANITARY SEWER PIPE	L.F.
50364	18 INCH CWPP SANITARY SEWER PIPE	L.F.
50365	21 INCH CWPP SANITARY SEWER PIPE	L.F.
50366	24 INCH CWPP SANITARY SEWER PIPE	L.F.
50367	30 INCH CWPP SANITARY SEWER PIPE	L.F.
50368	36 INCH CWPP SANITARY SEWER PIPE	L.F.
50370	TRACER WIRE AND BOX	L.F.
50390	SEWER ELECTRONIC MARKERS	EACH
50401	12 INCH STORM SEWER PIPE	L.F.
50402	15 INCH STORM SEWER PIPE	L.F.
50411	12 INCH RCP STORM SEWER PIPE	L.F.
50412	15 INCH RCP STORM SEWER PIPE	L.F.
50413	18 INCH RCP STORM SEWER PIPE	L.F.
50414	21 INCH RCP STORM SEWER PIPE	L.F.
50415	24 INCH RCP STORM SEWER PIPE	L.F.
50416	27 INCH RCP STORM SEWER PIPE	L.F.
50417	30 INCH RCP STORM SEWER PIPE	L.F.
50418	36 INCH RCP STORM SEWER PIPE	L.F.

## STANDARD BID ITEM NUMBERS

ITEM NUMBER	TYPE OF WORK	UNIT
50419	42 INCH RCP STORM SEWER PIPE	L.F.
50420	48 INCH RCP STORM SEWER PIPE	L.F.
50421	54 INCH RCP STORM SEWER PIPE	L.F.
50422	60 INCH RCP STORM SEWER PIPE	L.F.
50423	66 INCH RCP STORM SEWER PIPE	L.F.
50424	72 INCH RCP STORM SEWER PIPE	L.F.
50425	78 INCH RCP STORM SEWER PIPE	L.F.
50426	84 INCH RCP STORM SEWER PIPE	L.F.
50431	14 INCH X 23 INCH HERCP STORM SEWER PIPE	L.F.
50432	19 INCH X 30 INCH HERCP STORM SEWER PIPE	L.F.
50433	24 INCH X 38 INCH HERCP STORM SEWER PIPE	L.F.
50434	29 INCH X 45 INCH HERCP STORM SEWER PIPE	L.F.
50435	34 INCH X 53 INCH HERCP STORM SEWER PIPE	L.F.
50436	38 INCH X 60 INCH HERCP STORM SEWER PIPE	L.F.
50437	43 INCH X 68 INCH HERCP STORM SEWER PIPE	L.F.
50438	48 INCH X 76 INCH HERCP STORM SEWER PIPE	L.F.
50439	53 INCH X 83 INCH HERCP STORM SEWER PIPE	L.F.
50440	58 INCH X 91 INCH HERCP STORM SEWER PIPE	L.F.
50441	63 INCH X 98 INCH HERCP STORM SEWER PIPE	L.F.
50442	68 INCH X 106 INCH HERCP STORM SEWER PIPE	L.F.
50443	72 INCH X 113 INCH HERCP STORM SEWER PIPE	L.F.
50444	77 INCH X 123 INCH HERCP STORM SEWER PIPE	L.F.
50451	<i>RESERVED FOR STORM SEWER WYES, TEES, ANGLES, OR OTHER PRECAST SECTIONS</i>	EACH
50461	12 INCH RCP AE	EACH
50462	15 INCH RCP AE	EACH
50463	18 INCH RCP AE	EACH
50464	21 INCH RCP AE	EACH
50465	24 INCH RCP AE	EACH
50466	27 INCH RCP AE	EACH
50467	30 INCH RCP AE	EACH
50468	36 INCH RCP AE	EACH
50469	42 INCH RCP AE	EACH
50470	48 INCH RCP AE	EACH
50471	54 INCH RCP AE	EACH
50472	60 INCH RCP AE	EACH
50473	66 INCH RCP AE	EACH
50474	72 INCH RCP AE	EACH
50475	78 INCH RCP AE	EACH
50476	84 INCH RCP AE	EACH
50481	14 INCH X 23 INCH HERCP AE	EACH
50482	19 INCH X 30 INCH HERCP AE	EACH
50483	24 INCH X 38 INCH HERCP AE	EACH
50484	29 INCH X 45 INCH HERCP AE	EACH
50485	34 INCH X 53 INCH HERCP AE	EACH
50486	38 INCH X 60 INCH HERCP AE	EACH
50487	43 INCH X 68 INCH HERCP AE	EACH
50488	48 INCH X 76 INCH HERCP AE	EACH
50489	53 INCH X 83 INCH HERCP AE	EACH
50490	58 INCH X 91 INCH HERCP AE	EACH
50491	63 INCH X 98 INCH HERCP AE	EACH
50492	68 INCH X 106 INCH HERCP AE	EACH
50493	72 INCH X 113 INCH HERCP AE	EACH
50494	77 INCH X 123 INCH HERCP AE	EACH
50498	JOINT TIES	EACH

## STANDARD BID ITEM NUMBERS

ITEM NUMBER	TYPE OF WORK	UNIT
50499	CONCRETE COLLAR	EACH
50501	<i>RESERVED FOR BOX CULVERTS</i>	L.F.
50511	<i>RESERVED FOR BOX CULVERT WINGWALLS</i>	EACH
50601	12 INCH RCP AE GATE	EACH
50602	15 INCH RCP AE GATE	EACH
50603	18 INCH RCP AE GATE	EACH
50604	21 INCH RCP AE GATE	EACH
50605	24 INCH RCP AE GATE	EACH
50606	27 INCH RCP AE GATE	EACH
50607	30 INCH RCP AE GATE	EACH
50608	36 INCH RCP AE GATE	EACH
50609	42 INCH RCP AE GATE	EACH
50610	48 INCH RCP AE GATE	EACH
50611	54 INCH RCP AE GATE	EACH
50612	60 INCH RCP AE GATE	EACH
50613	66 INCH RCP AE GATE	EACH
50614	72 INCH RCP AE GATE	EACH
50615	78 INCH RCP AE GATE	EACH
50616	84 INCH RCP AE GATE	EACH
50621	14 INCH X 23 INCH HERCP AE GATE	EACH
50622	19 INCH X 30 INCH HERCP AE GATE	EACH
50623	24 INCH X 38 INCH HERCP AE GATE	EACH
50624	29 INCH X 45 INCH HERCP AE GATE	EACH
50625	34 INCH X 53 INCH HERCP AE GATE	EACH
50626	38 INCH X 60 INCH HERCP AE GATE	EACH
50627	43 INCH X 68 INCH HERCP AE GATE	EACH
50628	48 INCH X 76 INCH HERCP AE GATE	EACH
50629	53 INCH X 83 INCH HERCP AE GATE	EACH
50630	58 INCH X 91 INCH HERCP AE GATE	EACH
50631	63 INCH X 98 INCH HERCP AE GATE	EACH
50632	68 INCH X 106 INCH HERCP AE GATE	EACH
50633	72 INCH X 113 INCH HERCP AE GATE	EACH
50634	77 INCH X 123 INCH HERCP AE GATE	EACH
50641	<i>RESERVED FOR BOX CULVERT INLET GATES</i>	EACH
50651	<i>RESERVED FOR BOX CULVERT OUTLET GATES</i>	EACH
50701	4' DIA. SANITARY SAS	EACH
50702	5' DIA. SANITARY SAS	EACH
50711	4' DIA. SANITARY SAS WITH SALVAGED CASTING	EACH
50712	5' DIA. SANITARY SAS WITH SALVAGED CASTING	EACH
50721	3'X3' CATCHBASIN	EACH
50722	6'X6' CATCHBASIN	EACH
50723	3'X3' STORM SAS	EACH
50724	4'X4' STORM SAS	EACH
50725	5'X5' STORM SAS	EACH
50726	6'X6' STORM SAS	EACH
50727	SADDLED STORM	EACH
50731	3'X3' CATCHBASIN WITH SALVAGED CASTING	EACH
50732	6'X6' CATCHBASIN WITH SALVAGED CASTING	EACH
50733	3'X3' STORM SAS WITH SALVAGED CASTING	EACH
50734	4'X4' STORM SAS WITH SALVAGED CASTING	EACH
50735	5'X5' STORM SAS WITH SALVAGED CASTING	EACH
50736	6'X6' STORM SAS WITH SALVAGED CASTING	EACH

## STANDARD BID ITEM NUMBERS

ITEM NUMBER	TYPE OF WORK	UNIT
50741	TYPE "H" INLET	EACH
50742	TYPE "S" INLET	EACH
50751	TYPE "H" INLET WITH SALVAGED CASTING	EACH
50752	TYPE "S" INLET WITH SALVAGED CASTING	EACH
50761	SADDLED INLET TYPE I	EACH
50762	SADDLED INLET TYPE II	EACH
50763	TERRACE INLET	EACH
50764	CURB OUTLET STRUCTURE	EACH
50765	DITCH INLET STRUCTURE	EACH
50766	TERRACE INLET TYPE 1	EACH
50767	TERRACE INLET TYPE 2	EACH
50768	TERRACE INLET TYPE 3	EACH
50769	TERRACE INLET TYPE 4	EACH
50770	TERRACE INLET TYPE 5	EACH
50771	INTERNAL CHIMNEY SEAL	EACH
50780	CLEANOUT	EACH
50781	8 INCH SANITARY SEWER OUTSIDE DROP	V.F
50782	10 INCH SANITARY SEWER OUTSIDE DROP	V.F
50783	INSIDE DROP	V.F
50791	SANITARY SEWER TAP	EACH
50792	STORM SEWER TAP	EACH
50793	PRIVATE STORM SEWER RECONNECT, TYPE 1	EACH
50794	PRIVATE STORM SEWER RECONNECT, TYPE 2	EACH
50801	UTILITY LINE OPENING (ULO)	EACH
50802	CONCRETE SUPPORTS	EACH
50803	REINFORCED CONCRETE BEAM SUPPORT	EACH
50901	FURNISH AND INSTALL CIPP TO REHABILITATE 6-INCH DIAMETER SANITARY SEWER MAINS	L.F.
50902	FURNISH AND INSTALL CIPP TO REHABILITATE 8-INCH DIAMETER SANITARY SEWER MAINS	L.F.
50903	FURNISH AND INSTALL CIPP TO REHABILITATE 10-INCH DIAMETER SANITARY SEWER MAINS	L.F.
50904	FURNISH AND INSTALL CIPP TO REHABILITATE 12-INCH DIAMETER SANITARY SEWER MAINS	L.F.
50905	FURNISH AND INSTALL CIPP TO REHABILITATE 15-INCH DIAMETER SANITARY SEWER MAINS	L.F.
50906	FURNISH AND INSTALL CIPP TO REHABILITATE 18-INCH DIAMETER SANITARY SEWER MAINS	L.F.
50907	FURNISH AND INSTALL CIPP TO REHABILITATE 21-INCH DIAMETER SANITARY SEWER MAINS	L.F.
50908	FURNISH AND INSTALL CIPP TO REHABILITATE 24-INCH DIAMETER SANITARY SEWER MAINS	L.F.
50909	REINSTATE AND RECONNECT SERVICE OPENINGS	EACH
50910	CHEMICAL GROUT SEALING OF SANITARY SEWER SERVICE	EACH
51001	STORM SEWER CLEANING AND TELEVISIONING	L.F.
60201	FURNISH & INSTALL 1 INCH CABLE-IN-DUCT BY "OPEN TRENCH" METHOD	L.F.
60202	INSTALL CITY-FURNISHED 1 INCH CABLE-IN-DUCT BY "OPEN TRENCH" METHOD	L.F.
60203	FURNISH & INSTALL 1 INCH CABLE-IN-DUCT	L.F.
60204	INSTALL CITY-FURNISHED 1 INCH CABLE-IN-DUCT	L.F.



## STANDARD BID ITEM NUMBERS

ITEM NUMBER	TYPE OF WORK	UNIT
60205	FURNISH & INSTALL 1 1/4 INCH CABLE-IN-DUCT BY "OPEN TRENCH" METHOD	L.F.
60206	INSTALL CITY-FURNISHED 1 1/4 INCH CABLE-IN-DUCT BY "OPEN TRENCH" METHOD	L.F.
60207	FURNISH & INSTALL 1 1/4 INCH CABLE-IN-DUCT	L.F.
60208	INSTALL CITY-FURNISHED 1 1/4 INCH CABLE-IN-DUCT	L.F.
60221	FURNISH & INSTALL 3 INCH PVC (SCHEDULE 80) CONDUIT BY "OPEN TRENCH" METHOD	L.F.
60222	FURNISH & INSTALL 3 INCH PVC (SCHEDULE 80) CONDUIT	L.F.
60223	FURNISH & INSTALL 3 INCH PVC (SCHEDULE 40) CONDUIT BY "OPEN TRENCH" METHOD	L.F.
60224	FURNISH & INSTALL 3 INCH PVC (SCHEDULE 40) CONDUIT	L.F.
60225	FURNISH & INSTALL 2 1/2 INCH PVC (SCHEDULE 80) CONDUIT BY "OPEN TRENCH" METHOD	L.F.
60226	FURNISH & INSTALL 2 1/2 INCH PVC (SCHEDULE 80) CONDUIT	L.F.
60227	FURNISH & INSTALL 2 1/2 INCH PVC (SCHEDULE 40) CONDUIT BY "OPEN TRENCH" METHOD	L.F.
60228	FURNISH & INSTALL 2 1/2 INCH PVC (SCHEDULE 40) CONDUIT	L.F.
60229	FURNISH & INSTALL 2 INCH PVC (SCHEDULE 80) CONDUIT BY "OPEN TRENCH" METHOD	L.F.
60230	FURNISH & INSTALL 2 INCH PVC (SCHEDULE 80) CONDUIT	L.F.
60231	FURNISH & INSTALL 2 INCH PVC (SCHEDULE 40) CONDUIT BY "OPEN TRENCH" METHOD	L.F.
60232	FURNISH & INSTALL 2 INCH PVC (SCHEDULE 40) CONDUIT	L.F.
60233	FURNISH & INSTALL 1 1/4 INCH PVC (SCHEDULE 40) CONDUIT BY "OPEN TRENCH" METHOD	L.F.
60234	FURNISH & INSTALL 1 1/4 INCH PVC (SCHEDULE 40) CONDUIT	L.F.
60235	FURNISH & INSTALL 1 INCH PVC (SCHEDULE 40) CONDUIT BY "OPEN TRENCH" METHOD	L.F.
60236	FURNISH & INSTALL 1 INCH PVC (SCHEDULE 40) CONDUIT	L.F.
60237	FURNISH & INSTALL 1 1/4 INCH PVC (SCHEDULE 80) CONDUIT BY "OPEN TRENCH" METHOD	L.F.
60238	FURNISH & INSTALL 1 1/4 INCH PVC (SCHEDULE 80) CONDUIT	L.F.
60241	GOPHER RACEWAY FOR ELECTRICAL CONDUIT OR CABLE-IN-DUCT	L.F.
60251	FURNISH & INSTALL 6 #4 AND 2 #8 WIRES IN EXISTING OR CONTRACTOR-INSTALLED CONDUIT	L.F.
60252	FURNISH & INSTALL 5 #4 AND 2 #8WIRES IN EXISTING OR CONTRACTOR-INSTALLED CONDUIT	L.F.
60253	FURNISH & INSTALL 3 #4 AND 1 #8 WIRES IN EXISTING OR CONTRACTOR-INSTALLED CONDUIT	L.F.
60254	FURNISH & INSTALL 2 #4 AND 1 #8 WIRES IN EXISTING OR CONTRACTOR-INSTALLED CONDUIT	L.F.
60255	FURNISH & INSTALL 3 #6 AND 1 #8 WIRES IN EXISTING OR CONTRACTOR-INSTALLED CONDUIT	L.F.
60256	FURNISH & INSTALL 2 #6 AND 1 #8 WIRES IN EXISTING OR CONTRACTOR-INSTALLED CONDUIT	L.F.
60301	REMOVE EXISTING AERIAL DISTRIBUTION WIRING	LUMP SUM
60401	CONSTRUCT LB-1 BASE	EACH
60402	CONSTRUCT LB-2 BASE	EACH
60403	CONSTRUCT LB-3 BASE	EACH
60404	CONSTRUCT LB-4 BASE	EACH
60405	CONSTRUCT LB-6 BASE	EACH
60406	CONSTRUCT LB-7 BASE	EACH
60407	CONSTRUCT LB-8 BASE	EACH
60408	CONSTRUCT LB-9 BASE	EACH
60409	CONSTRUCTION OFFSET BASE	EACH

## STANDARD BID ITEM NUMBERS

ITEM NUMBER	TYPE OF WORK	UNIT
60411	CONSTRUCT TYPE "G" BASE	EACH
60412	CONSTRUCT TYPE "M" BASE	EACH
60413	CONSTRUCT TYPE "P" BASE	EACH
60414	BASE FOR MULTISPACE PARKING METER	EACH
60421	REMOVE STREET LIGHT BASE	EACH
60422	REMOVE STREET LIGHT POLE	EACH
60423	REMOVE TRAFFIC SIGNAL BASE	EACH
60424	REMOVE TRAFFIC SIGNAL POLE	EACH
60425	REMOVE TRAFFIC SIGNAL OR STREETLIGHT CABINET	EACH
60426	REMOVE ELECTRICAL UTILITY ACCESS STRUCTURE	EACH
60427	REMOVE ELECTRICAL HANDHOLE	EACH
60428	REMOVE WOOD POLE	EACH
60431	ABANDON EXISTING HANDHOLE	EACH
60432	ABANDON ELECTRICAL UTILITY ACCESS STRUCTURE	EACH
60441	AUGER CONCRETE ELECTRICAL BASE	EACH
60501	INSTALL CITY FURNISHED STREET LIGHT UNIT	EACH
60502	INSTALL CITY-FURNISHED STREET LIGHT UNIT, TWIN ARMS	EACH
60503	INSTALL CITY-FURNISHED CONCRETE POLE STREET LIGHT UNIT	EACH
60504	INSTALL CITY-FURNISHED PEDESTRIAN STREET LIGHT UNIT	EACH
60261	ELECTRICAL TRENCH	L.F.
60262	ELECTRICAL TRENCH PAVED ROADWAY	EACH
60601	INSTALL UNMETERED ELECTRIC SERVICE	EACH
60602	INSTALL METERED ELECTRIC SERVICE	EACH
60701	CONSTRUCT ELECTRICAL UTILITY ACCESS STRUCTURE	EACH
60702	CONSTRUCT ELECTRICAL HANDHOLE TYPE 1	EACH
60703	CONSTRUCT ELECTRICAL HANDHOLE TYPE 2	EACH
60704	CONSTRUCT ELECTRICAL HANDHOLE TYPE 3	EACH
60705	CONSTRUCT ELECTRICAL HANDHOLE TYPE 4	EACH
60706	CONSTRUCT ELECTRICAL HANDHOLE TYPE 5	EACH
60707	CONSTRUCT ELECTRICAL BOX-OUT	EACH
60800	PAVEMENT MARKING EPOXY, LINE, 4-INCH	L.F.
60801	PAVEMENT MARKING EPOXY, DOUBLE LINE, 4-INCH	L.F.
60802	PAVEMENT MARKING EPOXY, LINE, 6-INCH	L.F.
60803	PAVEMENT MARKING EPOXY, LINE, 8-INCH	L.F.
60804	PAVEMENT MARKING EPOXY, LINE, 12-INCH	L.F.
60805	PAVEMENT MARKING EPOXY, RADIUS LINE, 4-INCH (5' LINE, 5' GAP)	L.F.
60806	PAVEMENT MARKING EPOXY, RADIUS LINE, 6-INCH (5' LINE, 5' GAP)	L.F.
60807	PAVEMENT MARKING EPOXY, RADIUS LINE, 8-INCH (5' LINE, 5' GAP)	L.F.
60808	PAVEMENT MARKING EPOXY, DIAGONAL LINE, 4-INCH	L.F.
60809	PAVEMENT MARKING EPOXY, DIAGONAL LINE, 6-INCH	L.F.
60810	PAVEMENT MARKING EPOXY, DIAGONAL LINE, 8-INCH	L.F.
60811	PAVEMENT MARKING EPOXY, DIAGONAL LINE, 12-INCH	L.F.
60812	PAVEMENT MARKING EPOXY, CROSSWALK, 6-INCH	L.F.
60813	PAVEMENT MARKING EPOXY, CROSSWALK, 8-INCH	L.F.
60814	PAVEMENT MARKING EPOXY, CROSSWALK, 12-INCH	L.F.
60815	PAVEMENT MARKING EPOXY, CROSSWALK, 18-INCH	L.F.
60816	PAVEMENT MARKING EPOXY, CONTINENTAL CROSSWALK, 18-INCH	L.F.
60817	PAVEMENT MARKING EPOXY, ROUNDABOUT EDGE LINE, 18-INCH	L.F.
60818	PAVEMENT MARKING EPOXY, STOP LINE, 24-INCH	L.F.
60819	PAVEMENT MARKING EPOXY, CURB	L.F.
60820	PAVEMENT MARKING EPOXY, MEDIAN NOSE	S.F.
60821	PAVEMENT MARKING EPOXY, PARKING STALL	L.F.
60822	PAVEMENT MARKING EPOXY, SYMBOL, BIKE SHARROW	EACH
60823	PAVEMENT MARKING EPOXY, SYMBOL, BIKE LANE	EACH

## STANDARD BID ITEM NUMBERS

ITEM NUMBER	TYPE OF WORK	UNIT
60824	PAVEMENT MARKING EPOXY, SYMBOL, BIKE STRAIGHT ARROW	EACH
60825	PAVEMENT MARKING EPOXY, SYMBOL, BIKE LEFT ARROW	EACH
60826	PAVEMENT MARKING EPOXY, SYMBOL, BIKE LANE & STRAIGHT ARROW	EACH
60827	PAVEMENT MARKING EPOXY, SYMBOL, BIKE LANE & LEFT ARROW	EACH
60828	PAVEMENT MARKING EPOXY, SYMBOL, BIKE DETECTOR	EACH
60829	PAVEMENT MARKING EPOXY, SYMBOL, LEFT ARROW	EACH
60830	PAVEMENT MARKING EPOXY, SYMBOL, RIGHT ARROW	EACH
60831	PAVEMENT MARKING EPOXY, SYMBOL, STRAIGHT ARROW	EACH
60832	PAVEMENT MARKING EPOXY, SYMBOL, STRAIGHT & LEFT ARROW	EACH
60833	PAVEMENT MARKING EPOXY, SYMBOL, STRAIGHT & RIGHT ARROW	EACH
60834	PAVEMENT MARKING EPOXY, WORD, ONLY	EACH
60835	PAVEMENT MARKING EPOXY, SYMBOL, RAILROAD CROSSING	EACH
60836	PAVEMENT MARKING EPOXY, SYMBOL, DIAMOND	EACH
60840	PAVEMENT MARKING PAINT, LINE, 4-INCH	L.F.
60841	PAVEMENT MARKING PAINT, DOUBLE LINE, 4-INCH	L.F.
60842	PAVEMENT MARKING PAINT, LINE, 6-INCH	L.F.
60843	PAVEMENT MARKING PAINT, LINE, 8-INCH	L.F.
60844	PAVEMENT MARKING PAINT, LINE, 12-INCH	L.F.
60845	PAVEMENT MARKING PAINT, RADIUS LINE, 4-INCH (5' LINE, 5' GAP)	L.F.
60846	PAVEMENT MARKING PAINT, RADIUS LINE, 6-INCH (5' LINE, 5' GAP)	L.F.
60847	PAVEMENT MARKING PAINT, RADIUS LINE, 8-INCH (5' LINE, 5' GAP)	L.F.
60848	PAVEMENT MARKING PAINT, DIAGONAL LINE, 4-INCH	L.F.
60849	PAVEMENT MARKING PAINT, DIAGONAL LINE, 6-INCH	L.F.
60850	PAVEMENT MARKING PAINT, DIAGONAL LINE, 8-INCH	L.F.
60851	PAVEMENT MARKING PAINT, DIAGONAL LINE, 12-INCH	L.F.
60852	PAVEMENT MARKING PAINT, CROSSWALK, 6-INCH	L.F.
60853	PAVEMENT MARKING PAINT, CROSSWALK, 8-INCH	L.F.
60854	PAVEMENT MARKING PAINT, CROSSWALK, 12-INCH	L.F.
60855	PAVEMENT MARKING PAINT, CROSSWALK, 18-INCH	L.F.
60856	PAVEMENT MARKING PAINT, CONTINENTAL CROSSWALK, 18-INCH	L.F.
60857	PAVEMENT MARKING PAINT, ROUNDABOUT EDGE LINE, 18-INCH	L.F.
60858	PAVEMENT MARKING PAINT, STOP LINE, 24-INCH	L.F.
60859	PAVEMENT MARKING PAINT, CURB	L.F.
60860	PAVEMENT MARKING PAINT, MEDIAN NOSE	S.F.
60861	PAVEMENT MARKING PAINT, PARKING STALL	L.F.
60862	PAVEMENT MARKING PAINT, SYMBOL, BIKE SHARROW	EACH
60863	PAVEMENT MARKING PAINT, SYMBOL, BIKE LANE	EACH
60864	PAVEMENT MARKING PAINT, SYMBOL, BIKE STRAIGHT ARROW	EACH
60865	PAVEMENT MARKING PAINT, SYMBOL, BIKE LEFT ARROW	EACH
60866	PAVEMENT MARKING PAINT, SYMBOL, BIKE LANE & STRAIGHT ARROW	EACH
60867	PAVEMENT MARKING PAINT, SYMBOL, BIKE LANE & LEFT ARROW	EACH
60868	PAVEMENT MARKING PAINT, SYMBOL, BIKE DETECTOR	EACH
60869	PAVEMENT MARKING PAINT, SYMBOL, LEFT ARROW	EACH
60870	PAVEMENT MARKING PAINT, SYMBOL, RIGHT ARROW	EACH
60871	PAVEMENT MARKING PAINT, SYMBOL, STRAIGHT ARROW	EACH
60872	PAVEMENT MARKING PAINT, SYMBOL, STRAIGHT & LEFT ARROW	EACH
60873	PAVEMENT MARKING PAINT, SYMBOL, STRAIGHT & RIGHT ARROW	EACH
60874	PAVEMENT MARKING PAINT, WORD, ONLY	EACH
60875	PAVEMENT MARKING PAINT, SYMBOL, RAILROAD CROSSING	EACH
60876	PAVEMENT MARKING PAINT, SYMBOL, DIAMOND	EACH
60880	PAVEMENT MARKING REMOVAL, 4-INCH	L.F.
60881	PAVEMENT MARKING REMOVAL, 6-INCH	L.F.
60882	PAVEMENT MARKING REMOVAL, 8-INCH	L.F.
60883	PAVEMENT MARKING REMOVAL, 12-INCH	L.F.
60884	PAVEMENT MARKING REMOVAL, 18-INCH	L.F.

## STANDARD BID ITEM NUMBERS

ITEM NUMBER	TYPE OF WORK	UNIT
60885	PAVEMENT MARKING REMOVAL, 24-INCH	L.F.
60886	PAVEMENT MARKING REMOVAL, 4" DOUBLE LINE	L.F.
60887	PAVEMENT MARKING REMOVAL, SYMBOL, ARROW	EACH
60888	PAVEMENT MARKING REMOVAL, SYMBOL, WORD	EACH
60889	PAVEMENT MARKING REMOVAL, SYMBOL, BIKE LANE	EACH
60890	PAVEMENT MARKING REMOVAL, SYMBOL, BIKE SHARROW	EACH
60891	PAVEMENT MARKING REMOVAL, SYMBOL, BIKE ARROW	EACH
60892	PAVEMENT MARKING REMOVAL, SYMBOL, RAILROAD CROSSING	EACH
60893	PAVEMENT MARKING REMOVAL, SYMBOL, DIAMOND	EACH
60900	TEMPORARY PAVEMENT MARKING PAINT, LINE, 4-INCH	L.F.
60901	TEMPORARY PAVEMENT MARKING PAINT, DOUBLE LINE, 4-INCH	L.F.
60902	TEMPORARY PAVEMENT MARKING PAINT, LINE, 6-INCH	L.F.
60903	TEMPORARY PAVEMENT MARKING PAINT, LINE, 8-INCH	L.F.
60904	TEMPORARY PAVEMENT MARKING PAINT, LINE, 12-INCH	L.F.
60905	TEMPORARY PAVEMENT MARKING PAINT, RADIUS LINE, 4-INCH (5' LINE, 5' GAP)	L.F.
60906	TEMPORARY PAVEMENT MARKING PAINT, RADIUS LINE, 6-INCH (5' LINE, 5' GAP)	L.F.
60907	TEMPORARY PAVEMENT MARKING PAINT, RADIUS LINE, 8-INCH (5' LINE, 5' GAP)	L.F.
60908	TEMPORARY PAVEMENT MARKING PAINT, DIAGONAL LINE, 4-INCH	L.F.
60909	TEMPORARY PAVEMENT MARKING PAINT, DIAGONAL LINE, 6-INCH	L.F.
60910	TEMPORARY PAVEMENT MARKING PAINT, DIAGONAL LINE, 8-INCH	L.F.
60911	TEMPORARY PAVEMENT MARKING PAINT, DIAGONAL LINE, 12-INCH	L.F.
60912	TEMPORARY PAVEMENT MARKING PAINT, CROSSWALK, 6-INCH	L.F.
60913	TEMPORARY PAVEMENT MARKING PAINT, CROSSWALK, 8-INCH	L.F.
60914	TEMPORARY PAVEMENT MARKING PAINT, CROSSWALK, 12-INCH	L.F.
60915	TEMPORARY PAVEMENT MARKING PAINT, STOP LINE, 24-INCH	L.F.
60916	TEMPORARY PAVEMENT MARKING PAINT, SYMBOL, BIKE SHARROW	EACH
60917	TEMPORARY PAVEMENT MARKING PAINT, SYMBOL, BIKE LANE	EACH
60918	TEMPORARY PAVEMENT MARKING PAINT, SYMBOL, BIKE STRAIGHT ARROW	EACH
60919	TEMPORARY PAVEMENT MARKING PAINT, SYMBOL, BIKE LEFT ARROW	EACH
60920	TEMPORARY PAVEMENT MARKING PAINT, SYMBOL, BIKE LANE & STRAIGHT ARROW	EACH
60921	TEMPORARY PAVEMENT MARKING PAINT, SYMBOL, BIKE LANE & LEFT ARROW	EACH
60922	TEMPORARY PAVEMENT MARKING PAINT, SYMBOL, BIKE DETECTOR	EACH
60923	TEMPORARY PAVEMENT MARKING PAINT, SYMBOL, LEFT ARROW	EACH
60924	TEMPORARY PAVEMENT MARKING PAINT, SYMBOL, RIGHT ARROW	EACH
60925	TEMPORARY PAVEMENT MARKING PAINT, SYMBOL, STRAIGHT ARROW	EACH
60926	TEMPORARY PAVEMENT MARKING PAINT, SYMBOL, STRAIGHT & LEFT ARROW	EACH
60927	TEMPORARY PAVEMENT MARKING PAINT, SYMBOL, STRAIGHT & RIGHT ARROW	EACH
60928	TEMPORARY PAVEMENT MARKING PAINT, WORD, ONLY	EACH
60940	TEMPORARY PAVEMENT MARKING TAPE, REMOVABLE, REFLECTIVE, LINE, 4-INCH	L.F.
60941	TEMPORARY PAVEMENT MARKING TAPE, REMOVABLE, REFLECTIVE, DOUBLE LINE, 4-INCH	L.F.
60942	TEMPORARY PAVEMENT MARKING TAPE, REMOVABLE, REFLECTIVE, LINE, 6-INCH	L.F.
60943	TEMPORARY PAVEMENT MARKING TAPE, REMOVABLE, REFLECTIVE, LINE, 8-INCH	L.F.

## STANDARD BID ITEM NUMBERS

ITEM NUMBER	TYPE OF WORK	UNIT
60944	TEMPORARY PAVEMENT MARKING TAPE, REMOVABLE, REFLECTIVE, LINE, 12-INCH	L.F.
60945	TEMPORARY PAVEMENT MARKING TAPE, REMOVABLE, REFLECTIVE, LINE, 24-INCH	L.F.
60946	TEMPORARY PAVEMENT MARKING TAPE, REMOVABLE, REFLECTIVE, SYMBOL, BIKE SHARROW	EACH
60947	TEMPORARY PAVEMENT MARKING TAPE, REMOVABLE, REFLECTIVE, SYMBOL, BIKE LANE	EACH
60948	TEMPORARY PAVEMENT MARKING TAPE, REMOVABLE, REFLECTIVE, SYMBOL, BIKE STRAIGHT ARROW	EACH
60949	TEMPORARY PAVEMENT MARKING TAPE, REMOVABLE, REFLECTIVE, SYMBOL, BIKE LEFT ARROW	EACH
60950	TEMPORARY PAVEMENT MARKING TAPE, REMOVABLE, REFLECTIVE, SYMBOL, BIKE LANE & STRAIGHT ARROW	EACH
60951	TEMPORARY PAVEMENT MARKING TAPE, REMOVABLE, REFLECTIVE, SYMBOL, BIKE LANE & LEFT ARROW	EACH
60952	TEMPORARY PAVEMENT MARKING TAPE, REMOVABLE, REFLECTIVE, SYMBOL, BIKE DETECTOR	EACH
60953	TEMPORARY PAVEMENT MARKING TAPE, REMOVABLE, REFLECTIVE, SYMBOL, LEFT ARROW	EACH
60954	TEMPORARY PAVEMENT MARKING TAPE, REMOVABLE, REFLECTIVE, SYMBOL, RIGHT ARROW	EACH
60955	TEMPORARY PAVEMENT MARKING TAPE, REMOVABLE, REFLECTIVE, SYMBOL, STRAIGHT ARROW	EACH
60956	TEMPORARY PAVEMENT MARKING TAPE, REMOVABLE, REFLECTIVE, SYMBOL, STRAIGHT & LEFT ARROW	EACH
60957	TEMPORARY PAVEMENT MARKING TAPE, REMOVABLE, REFLECTIVE, SYMBOL, STRAIGHT & RIGHT ARROW	EACH
60958	TEMPORARY PAVEMENT MARKING TAPE, REMOVABLE, REFLECTIVE, WORD, ONLY	EACH
60970	TEMPORARY PAVEMENT MARKING TAPE, REMOVABLE, LINE, 4-INCH	L.F.
60971	TEMPORARY PAVEMENT MARKING TAPE, REMOVABLE, DOUBLE LINE, 4-INCH	L.F.
60972	TEMPORARY PAVEMENT MARKING TAPE, REMOVABLE, LINE, 6-INCH	L.F.
60973	TEMPORARY PAVEMENT MARKING TAPE, REMOVABLE, LINE, 8-INCH	L.F.
60974	TEMPORARY PAVEMENT MARKING TAPE, REMOVABLE, LINE, 12-INCH	L.F.
60975	TEMPORARY PAVEMENT MARKING TAPE, REMOVABLE, LINE, 24-INCH	L.F.
70001	FURNISH AND INSTALL 4 INCH PIPE & FITTINGS	L.F.
70002	FURNISH AND INSTALL 6 INCH PIPE & FITTINGS	L.F.
70003	FURNISH AND INSTALL 8 INCH PIPE & FITTINGS	L.F.
70004	FURNISH AND INSTALL 10 INCH PIPE & FITTINGS	L.F.
70005	FURNISH AND INSTALL 12 INCH PIPE & FITTINGS	L.F.
70006	FURNISH AND INSTALL 16 INCH PIPE & FITTINGS	L.F.
70007	FURNISH AND INSTALL 20 INCH PIPE & FITTINGS	L.F.
70008	FURNISH AND INSTALL 24 INCH PIPE & FITTINGS	L.F.
70010	HORIZONTAL DIRECTIONAL DRILL 8 INCH PIPE	L.F.
70011	HORIZONTAL DIRECTIONAL DRILL 10 INCH PIPE	L.F.
70012	HORIZONTAL DIRECTIONAL DRILL 12 INCH PIPE	L.F.
70013	HORIZONTAL DIRECTIONAL DRILL 16 INCH PIPE	L.F.
70014	HORIZONTAL DIRECTIONAL DRILL 20 INCH PIPE	L.F.
70015	HORIZONTAL DIRECTIONAL DRILL 24 INCH PIPE	L.F.
70020	FURNISH AND INSTALL 18 INCH STEEL CASING	L.F.
70021	FURNISH AND INSTALL 20 INCH STEEL CASING	L.F.

## STANDARD BID ITEM NUMBERS

ITEM NUMBER	TYPE OF WORK	UNIT
70022	FURNISH AND INSTALL 24 INCH STEEL CASING	L.F.
70023	FURNISH AND INSTALL 30 INCH STEEL CASING	L.F.
70030	FURNISH AND INSTALL 4-INCH WATER VALVE	EACH
70031	FURNISH AND INSTALL 6-INCH WATER VALVE	EACH
70032	FURNISH AND INSTALL 8-INCH WATER VALVE	EACH
70033	FURNISH AND INSTALL 10-INCH WATER VALVE	EACH
70034	FURNISH AND INSTALL 12-INCH WATER VALVE	EACH
70035	FURNISH AND INSTALL 16-INCH WATER VALVE	EACH
70036	FURNISH AND INSTALL 20-INCH WATER VALVE	EACH
70040	FURNISH AND INSTALL HYDRANT	EACH
70041	RELOCATE HYDRANT	EACH
70051	FURNISH AND INSTALL 1 1/2 INCH SERVICE LATERALS	L.F.
70052	FURNISH AND INSTALL 2 INCH SERVICE LATERALS	L.F.
70053	REPLACE 1-INCH COPPER SERVICE LATERAL	L.F.
70054	REPLACE 1 1/2-INCH COPPER SERVICE LATERAL	L.F.
70055	REPLACE 2-INCH COPPER SERVICE LATERAL	L.F.
70056	EXTEND AND RECONNECT 1-INCH SERVICE LATERAL	L.F.
70057	EXTEND AND RECONNECT 1 1/2-INCH SERVICE LATERAL	L.F.
70058	EXTEND AND RECONNECT 2-INCH SERVICE LATERAL	L.F.
70059	DISCONNECT / RECONNECT 1-INCH SERVICE LATERAL	EACH
70060	DISCONNECT / RECONNECT 1 1/2-INCH SERVICE LATERAL	EACH
70061	DISCONNECT / RECONNECT 2-INCH SERVICE LATERAL	EACH
70070	SELECT FILL - SAND FOR WATER	L.F.
70080	CUT-IN OR CONNECT TO EXISTING WATER SYSTEM	EACH
70081	FURNISH EXCAVATION AND DITCH FOR LIVE TAP	EACH
70082	CUT OFF EXISTING WATER MAIN	EACH
70090	ABANDON WATER VALVE BOX	EACH
70091	ABANDON HYDRANT	EACH
70092	ABANDON WATER VALVE ACCESS STRUCTURE	EACH
70101	FURNISH AND INSTALL STYROFOAM	L.F.
70102	LANDSCAPE RESTORATION FOR WATER MAIN	L.F.
70103	WATER VALVE ACCESS STRUCTURE	EACH
70104	ADJUST WATER VALVE BOX	EACH
70105	PIPE PLUG FOR WATER MAIN INSTALLATION	EACH
70106	ROCK EXCAVATION	C.Y.
70107	REMOVAL OF EXCESS AMOUNTS OF BOULDERS	C.Y.
70108	ADDITIONAL EXCAVATION	C.Y.
70109	UNDERCUT	C.Y.

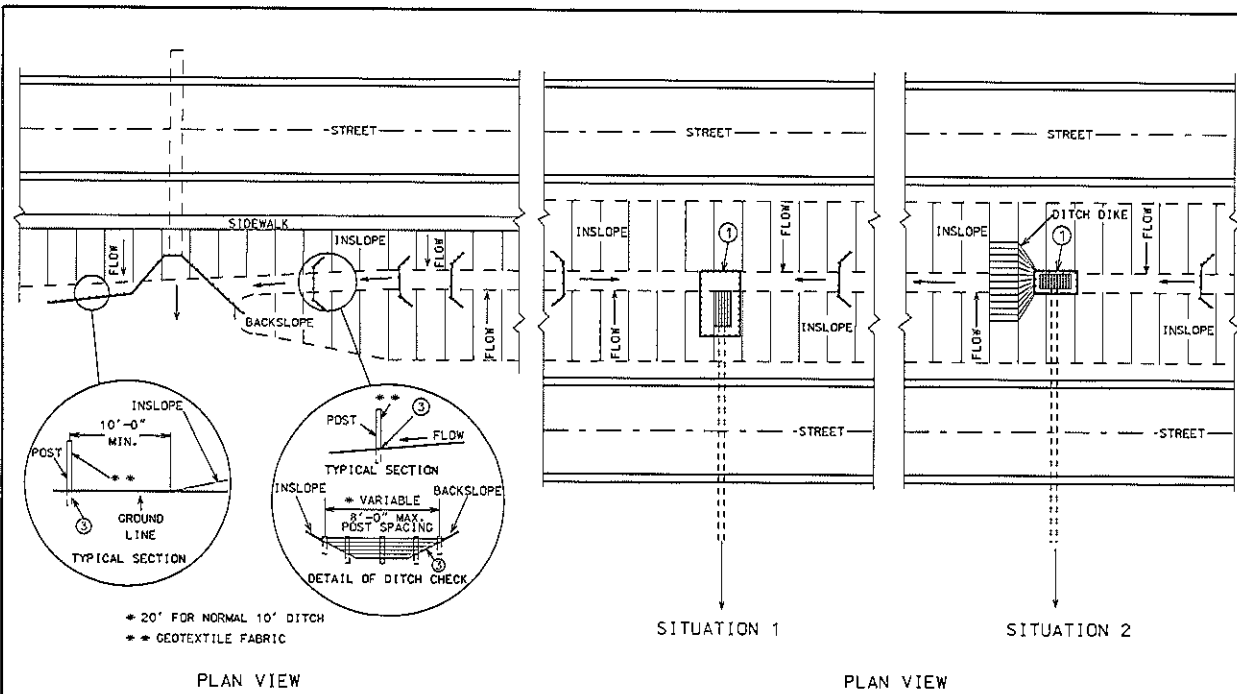

TYPICAL APPLICATIONS OF SILT FENCE

SILT FENCE AT MEDIAN SURFACE DRAINS

GENERAL NOTES

DETAIL OF CONSTRUCTION NOT SHOWN ON THIS DRAWING SHALL CONFORM TO THE PERTINENT REQUIREMENTS OF THE STANDARD SPECIFICATIONS AND APPLICABLE SPECIAL PROVISIONS.

- ① WHEN POSSIBLE THE SILT FENCE SHOULD BE CONSTRUCTED IN AN ARC OR HORSESHOE SHAPE WITH THE ENDS POINTING UPSLOPE TO MAXIMIZE BOTH STRENGTH AND EFFECTIVENESS.
  - ① CROSS BRACE WITH 2" X 4" WOODEN FRAME OR EQUIVALENT AT TOP OF POSTS AS DIRECTED BY THE ENGINEER.
  - ② MINIMUM 14 GAGE WIRE REQUIRED. FOLD FABRIC 3" OVER THE WIRE AND STAPLE OR PLACE WIRE RINGS ON 12" C-C.
  - ③ EXCAVATE A TRENCH A MINIMUM OF 4" WIDE & 6" DEEP TO BURY AND ANCHOR THE GEOTEXTILE FABRIC. FOLD MATERIAL TO FIT TRENCH AND BACKFILL & COMPACT TRENCH WITH EXCAVATED SOIL.
  - ④ WIRE SUPPORT FENCE SHALL BE 14 GAGE MINIMUM WOVEN WIRE WITH A MAXIMUM MESH SPACING OF 6". SECURE TOP OF GEOTEXTILE FABRIC TO TOP OF FENCE WITH STAPLES OR WIRE RINGS AT 12" C-C.
  - ⑤ GEOTEXTILE FABRIC SHALL BE REINFORCED WITH AN INDUSTRIAL POLYPROPYLENE NETTING WITH A MAXIMUM MESH SPACING OF 3/4" OR EQUAL. A HEAVY DUTY NYLON TOP SUPPORT CORD OR EQUIVALENT IS REQUIRED.
  - ⑥ STEEL POSTS SHALL BE STUDDED "TEE" OR "U" TYPE WITH A MINIMUM WEIGHT OF 1.28 LBS./LINEAL FOOT (WITHOUT ANCHOR). FIN ANCHORS SUFFICIENT TO RESIST POST MOVEMENT ARE REQUIRED. WOOD POSTS SHALL BE A MINIMUM SIZE OF 4" DIA. OR 1 1/2" X 3 1/8" EXCEPT WOOD POSTS FOR GEOTEXTILE FABRIC REINFORCED WITH NETTING SHALL BE A MINIMUM SIZE OF 1 1/8" X 1 1/8" OAK OR HICKORY.
- ALTERNATES A & B ARE EQUAL AND EITHER MAY BE USED.
- ⑦ REMOVAL OF ACCUMULATED SILT IS REQUIRED ONCE IT REACHES HALF THE HEIGHT OF THE SILT FENCE.

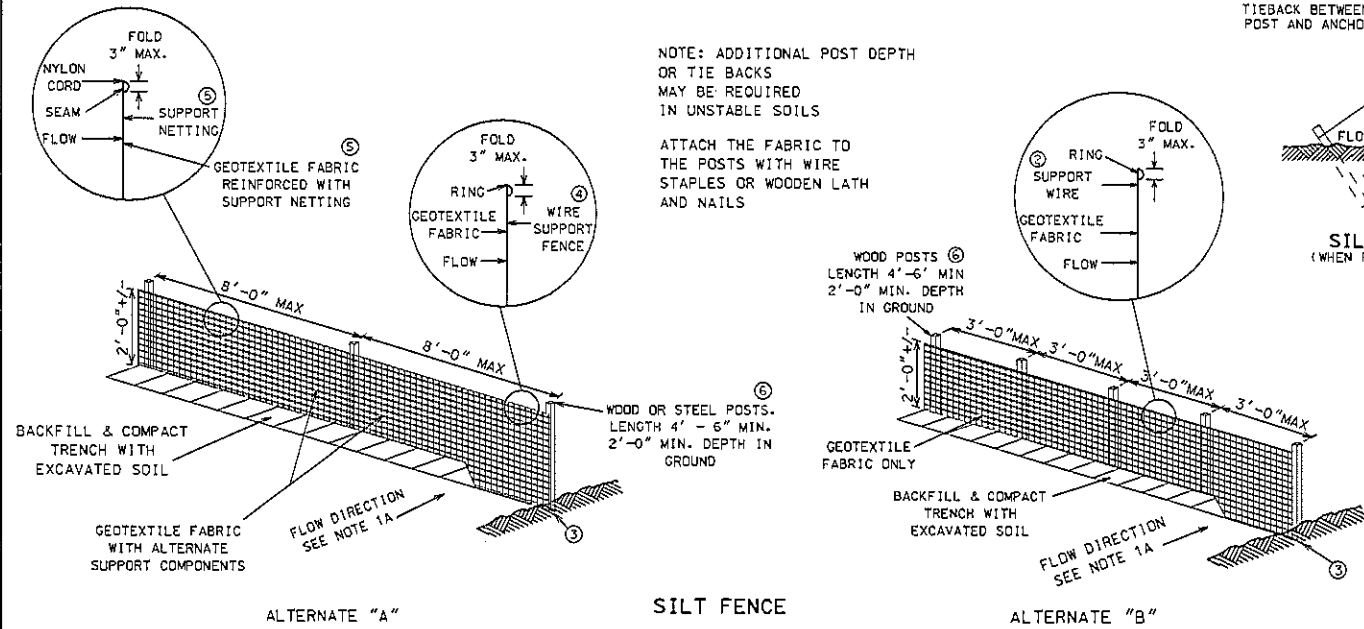

ALTERNATE "A"

SILT FENCE

ALTERNATE "B"

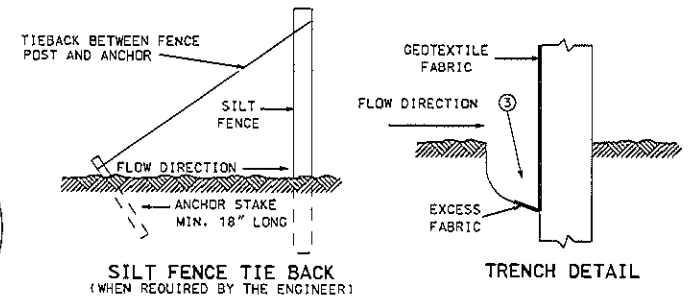

SILT FENCE TIE BACK (WHEN REQUIRED BY THE ENGINEER)

TRENCH DETAIL

2012

CITY OF MADISON  
ENGINEERING DIVISION

SILT FENCE

STANDARD DETAIL DRAWING 1.01

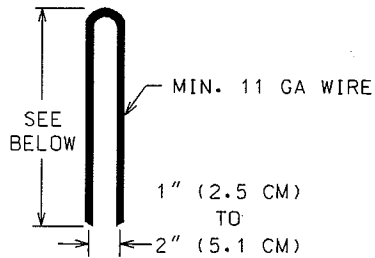

**DETAIL OF  
TYPICAL STAPLE**

6" (15.2cm) MIN. FOR FIRM SOILS  
 12" (30.5 cm) MIN. FOR LOOSE SOILS  
 8" (20.3 cm) MIN. WHERE BOTH SOD & MATS ARE BEING USED

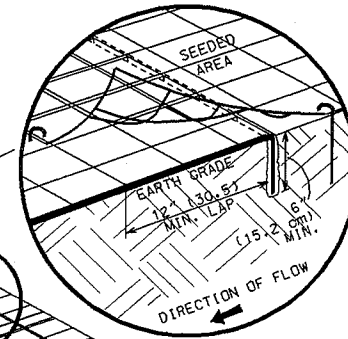
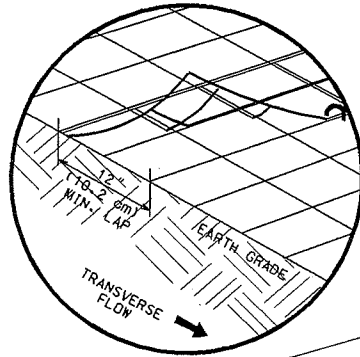

**JUNCTION SLOT  
(SEED ONLY)**

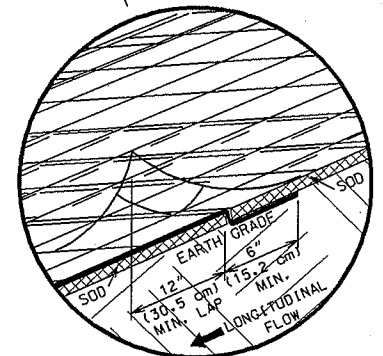
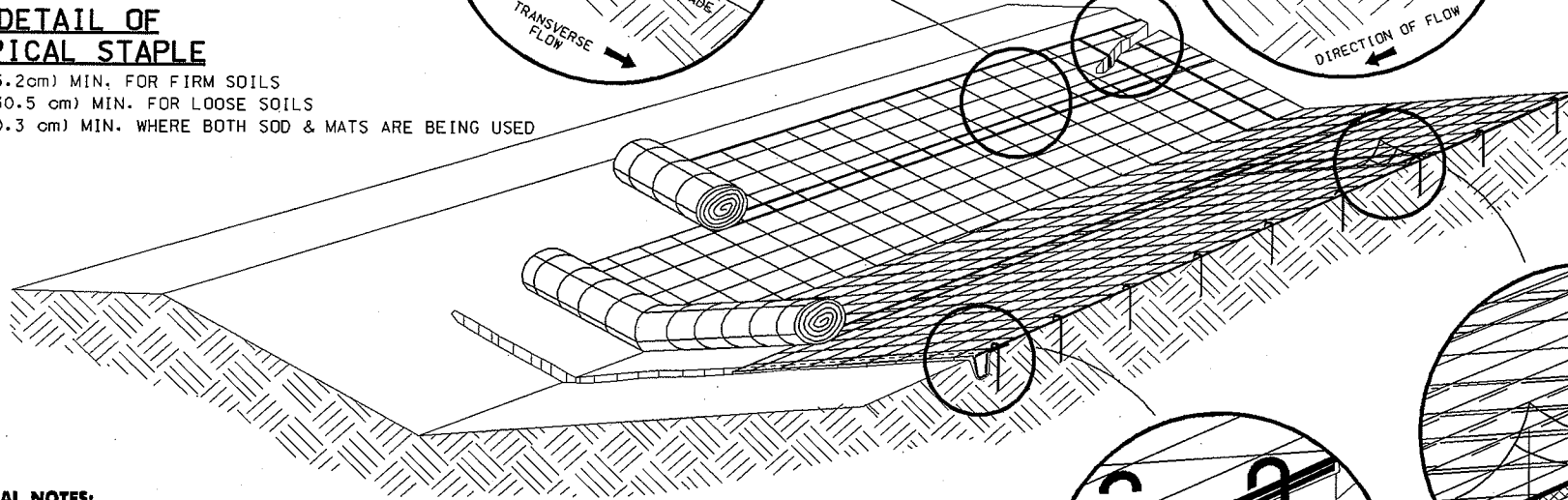

**JUNCTION SLOT  
(SOD ONLY)**

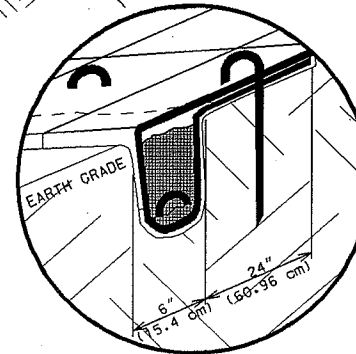

**ANCHOR SLOT  
AT BEGINNING OF EROSION MAT  
EXTRA STAPLE AT END ONLY  
(SEED AND SOD)**

**GENERAL NOTES:**

DETAILS OF CONSTRUCTION MATERIALS AND WORKMANSHIP NOT SHOWN ON THIS DRAWING SHALL CONFORM TO THE PERTINENT REQUIREMENTS OF THE STANDARD SPECIFICATIONS AND THE APPLICABLE SPECIAL PROVISIONS.

VARIATIONS IN THE DIMENSIONS OR MATERIALS SHOWN HEREON SHALL BE PERMITTED IF THEY PROVIDE EQUIVALENT PROTECTION AND MATERIAL STRENGTH AND IF PRIOR APPROVAL OF THE ENGINEER IS OBTAINED.

LAP JOINTS SHALL NOT BE PLACED IN THE BOTTOM OF V-SHAPED DITCHES.

JUNCTION SLOTS ON ADJACENT STRIPS OF MATTING SHALL BE STAGGERED A MINIMUM OF 4 FEET (1.219 m) APART.

EROSION MAT SHALL BE MEASURED AND PAID FOR IN ACCORDANCE WITH THE STANDARD SPECIFICATIONS.

**EROSION MAT OVER SOD:**

- a. ONLY JUTE FABRIC WILL BE PERMITTED OVER SOD.
- b. WOOD STAKES FOR SOD MAY BE OMITTED BY THE ENGINEER IF EXISTING SLOPE AND SOIL CONDITIONS SO WARRANT.
- c. THE WIDTH OF EROSION MAT SHALL ALWAYS EXCEED THE SOD WIDTH.

**EROSION MAT OVER SEEDING:**

JUNCTION OR ANCHOR SLOTS SHALL BE AT MINIMUM INTERVALS OF 100 FEET (30.48 m) ON GRADES UP TO AND INCLUDING 3 PERCENT, AND 50 FEET (15.24 m) ON GRADES EXCEEDING 3 PERCENT.

2004

CITY OF MADISON  
ENGINEERING DIVISION

**EROSION MAT**

DRAWING NOT TO SCALE

STANDARD DETAIL DRAWING 1.02



1.03

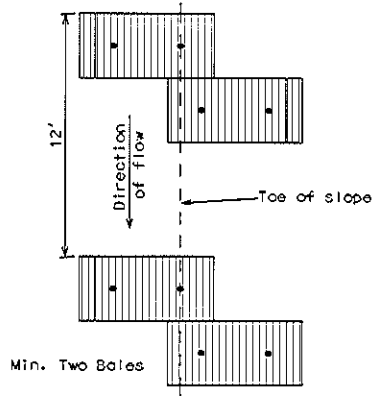

PLAN VIEW

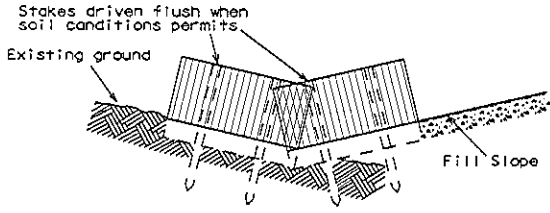

FRONT ELEVATION

EROSION BALES AT TOE OF SLOPE WHEN EXISTING GROUND SLOPES TOWARD FILL SLOPE

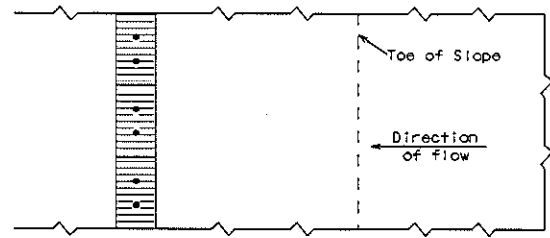

PLAN VIEW

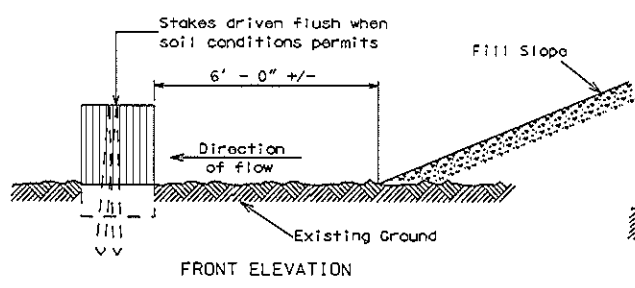

FRONT ELEVATION

EROSION BALES AT TOE OF SLOPE WHEN EXISTING GROUND SLOPES AWAY FROM FILL SLOPE

Wood Stakes (2 per Bale)  
Nominal 2" x 2" x 30" min.  
length or equivalent.

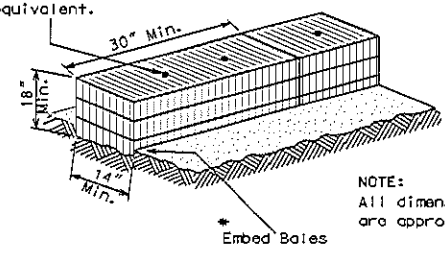

NOTE:  
All dimensions  
are approximate.

DETAIL OF EROSION BALE INSTALLATION

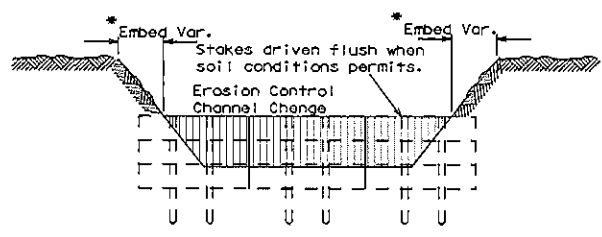

EROSION CONTROL CHANNEL CHANGE

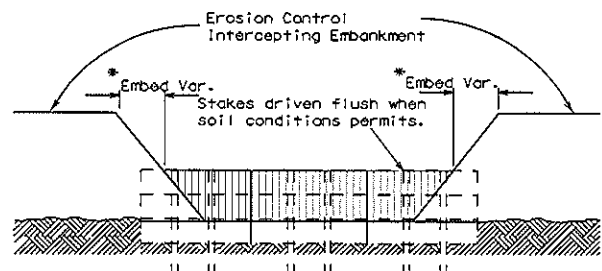

EROSION CONTROL INTERCEPTING EMBANKMENT

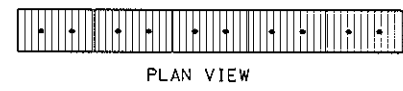

PLAN VIEW

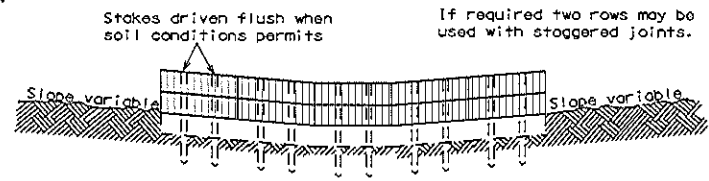

FRONT ELEVATION

EROSION BALES ACROSS DITCH BOTTOM

GENERAL NOTES

DETAILS OF CONSTRUCTION, MATERIALS AND WORKMANSHIP NOT SHOWN ON THIS DRAWING SHALL CONFORM TO THE PERTINENT REQUIREMENTS OF THE STANDARD SPECIFICATIONS AND THE APPLICABLE SPECIAL PROVISIONS.

BALES SHALL BE PLACED END TO END OR OVERLAPPING AT RIGHT ANGLES TO THE DIRECTION OF FLOW AND FAR ENOUGH UP THE SIDES OF THE DITCH TO PREVENT ERODING AROUND ENDS.

BALES SHALL BE PLACED WITH TWINE OR TIE WIRES PARALLEL TO THE GROUND.

STAKES TO BE BATTERED IN OPPOSITE DIRECTIONS.

ACCUMULATED SEDIMENT REMOVAL SHALL BE COMPLETED ONCE SEDIMENT DEPTH EQUALS TO HALF THE HEIGHT OF THE BALES.

\* AS DETERMINED BY THE ENGINEER.

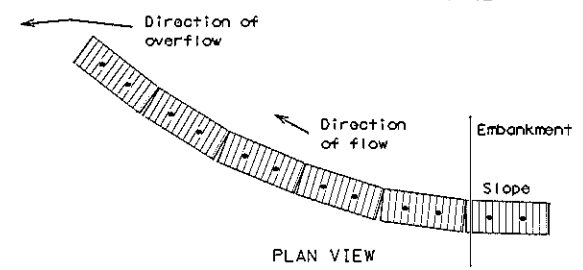

PLAN VIEW

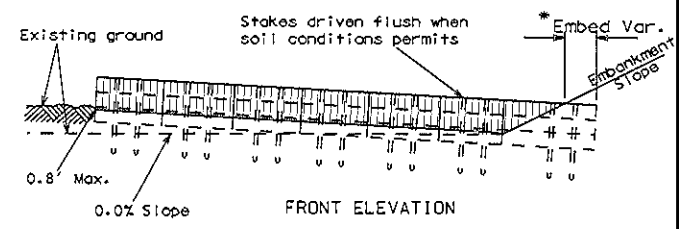

FRONT ELEVATION

EROSION BALES AT TOE OF SLOPE

2012

CITY OF MADISON  
ENGINEERING DIVISION

**TYPICAL INSTALLATIONS  
OF EROSION BALES**

STANDARD DETAIL DRAWING 1.03

WOOD 2X4 EXTENDS 8" BEYOND GRATE  
WIDTH ON BOTH SIDES. LENGTH = 52" FOR  
H--S INLETS. 94" FOR HH INLETS.

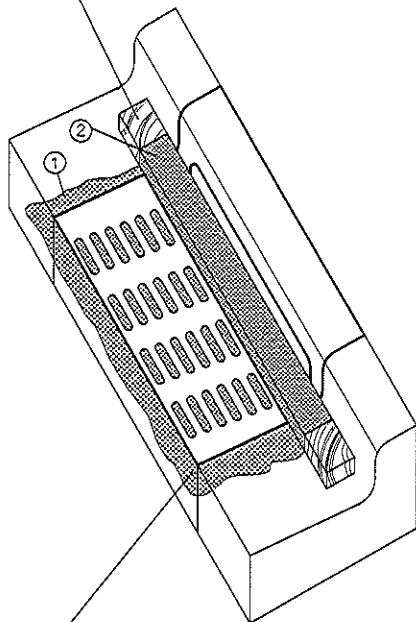

TYPE C = GEOTEXTILE FABRIC TYPE FF  
TYPE C "MODIFIED" = GEOTEXTILE FABRIC TYPE HR

GENERAL NOTES:

CLEANING IS REQUIRED WHEN FABRIC HOLDS  $\frac{1}{2}$ "  
OR MORE OF SEDIMENT OR WATER, OR AS DIRECTED  
BY THE CONSTRUCTION ENGINEER.

FABRIC SHALL BE REPLACED WHEN AN AREA UNDER THE GRATE  
HAS A TEAR 1" OR GREATER IN LENGTH,  
OR AT THE ENGINEERS DISCRETION.

THE WOOD SHALL NOT BLOCK THE ENTIRE HEIGHT OF THE  
CURB BOX.

MANUFACTURED ALTERNATIVES APPROVED AND LISTED ON THE  
WISDOT EROSION CONTROL PRODUCT ACCEPTIBILITY  
LIST MAY BE SUBSTITUTED.

WHEN REMOVING OR MAINTAINING INLET PROTECTION, CARE  
SHALL BE TAKEN SO THAT THE SEDIMENT TRAPPED ON THE  
GEOTEXTILE FABRIC DOES NOT FALL INTO THE INLET. ANY  
MATERIAL FALLING INTO THE INLET SHALL BE REMOVED  
IMMEDIATELY.

- ① FABRIC SIZE SHALL BE 8" (MIN) GREATER ON ALL SIDES  
OF THE INLET COVER TO PROVIDE A HAND HOLD WHEN  
MAINTENANCE OR REMOVAL IS REQUIRED.
- ② FOR INLET PROTECTION, TYPE C WITH A CURB BOX,  
AN ADDITIONAL 18" OF FABRIC IS WRAPPED AROUND  
THE WOOD AND SECURED WITH STAPLES.

2012

CITY OF MADISON  
ENGINEERING DIVISION

INLET PROTECTION  
TYPE C AND  
TYPE C "MODIFIED"

STANDARD DETAIL DRAWING 1.04

1.05

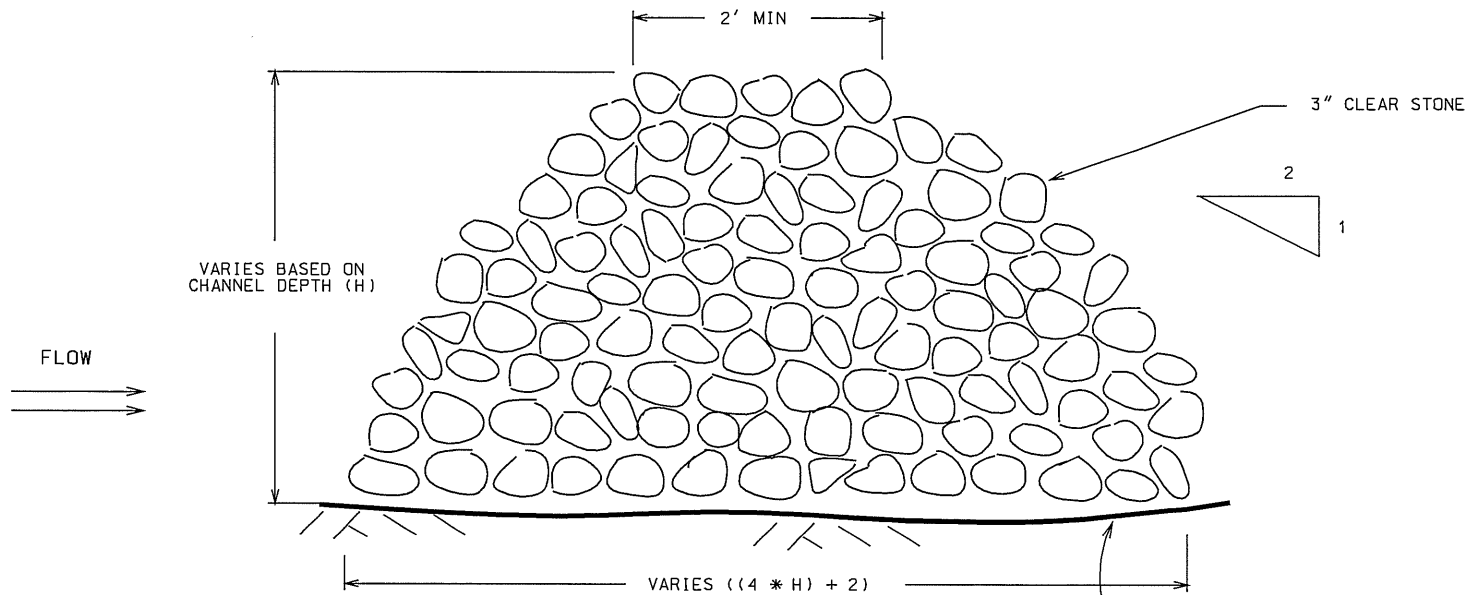

SIDE VIEW

EXTEND FILTER FABRIC  
1' PAST FOOT PRINT OF  
BERM IN ALL DIRECTIONS

TYPE HR  
FILTER FABRIC  
UNDERLYING  
CLEAR STONE

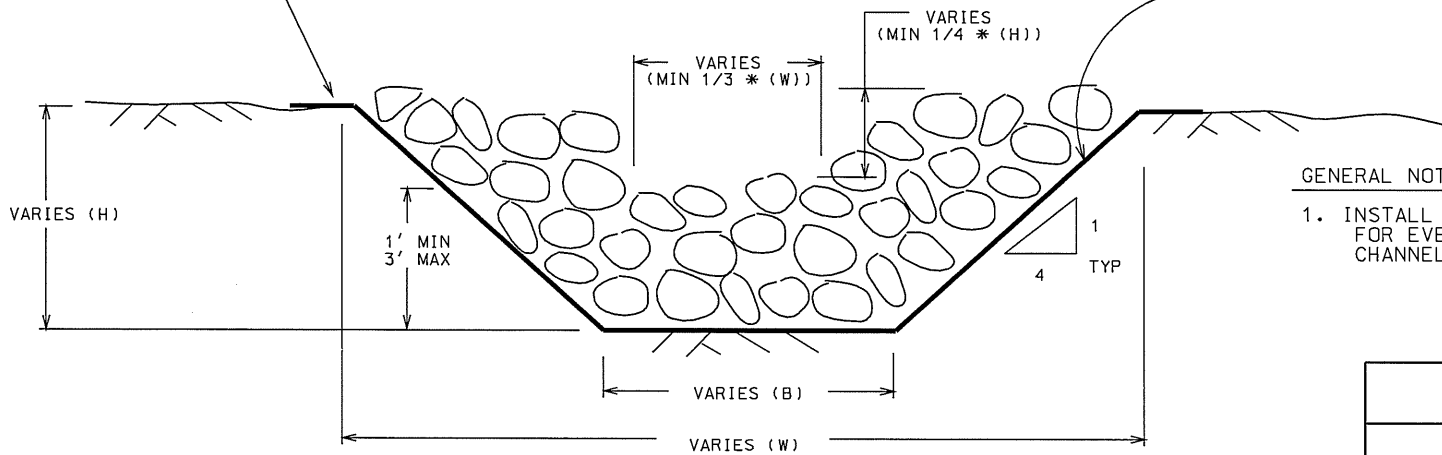

SECTION VIEW

GENERAL NOTES:

1. INSTALL A MINIMUM OF ONE DITCH CHECK FOR EVERY TWO FEET OF DROP IN THE CHANNEL.

2012

CITY OF MADISON  
ENGINEERING DIVISION

CLEAR STONE BERM  
(DITCH CHECK)

STANDARD DETAIL DRAWING 1.05

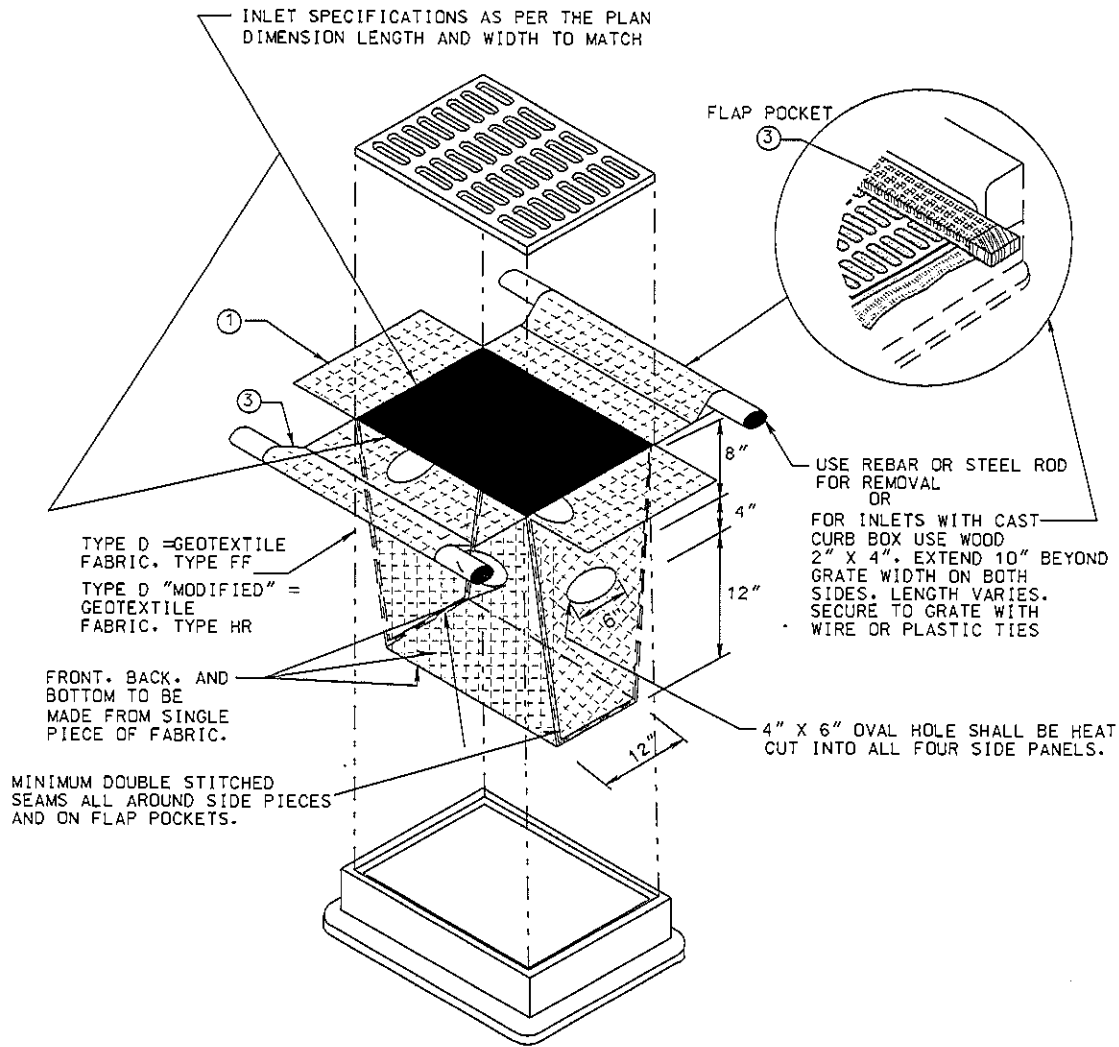

GENERAL NOTES

MANUFACTURED ALTERNATIVES APPROVED AND LISTED ON THE WisDOT'S EROSION CONTROL PRODUCT ACCEPTABILITY LIST MAY BE SUBSTITUTED.

CLEANING SHALL BE REQUIRED WHEN SEDIMENT OR STANDING WATER IS WITHIN 6" OF OVERFLOW HOLES OR AS DIRECTED BY THE CONSTRUCTION ENGINEER.

WHEN REMOVING OR MAINTAINING INLET PROTECTION, CARE SHALL BE TAKEN SO THAT THE SEDIMENT TRAPPED ON THE GEOTEXTILE FABRIC DOES NOT FALL INTO THE INLET. ANY MATERIAL FALLING INTO THE INLET SHALL BE REMOVED IMMEDIATELY.

THE INSTALLED BAG SHALL HAVE A MINIMUM SIDE CLEARANCE, BETWEEN THE INLET WALLS AND THE BAG, MEASURED AT THE BOTTOM OF THE OVERFLOW HOLES, OF 3". WHERE NECESSARY THE CONTRACTOR SHALL CINCH THE BAG, USING PLASTIC ZIP TIES, TO ACHIEVE THE 3" CLEARANCE. THE TIES SHALL BE PLACED AT A MAXIMUM OF 4" FROM THE BOTTOM OF THE BAG.

① TRIM EXCESS FABRIC IN THE FLOW LINE TO WITHIN 3" OF THE GRATE.

② FOR INLET PROTECTION WITH CURB BOX AN ADDITIONAL 18" OF FABRIC IS WRAPPED AROUND THE WOOD AND SECURED WITH STAPLES. THE WOOD SHALL NOT BLOCK THE ENTIRE HEIGHT OF THE CURB BOX OPENING.

③ FLAP POCKETS SHALL BE LARGE ENOUGH TO ACCEPT WOOD 2X4.

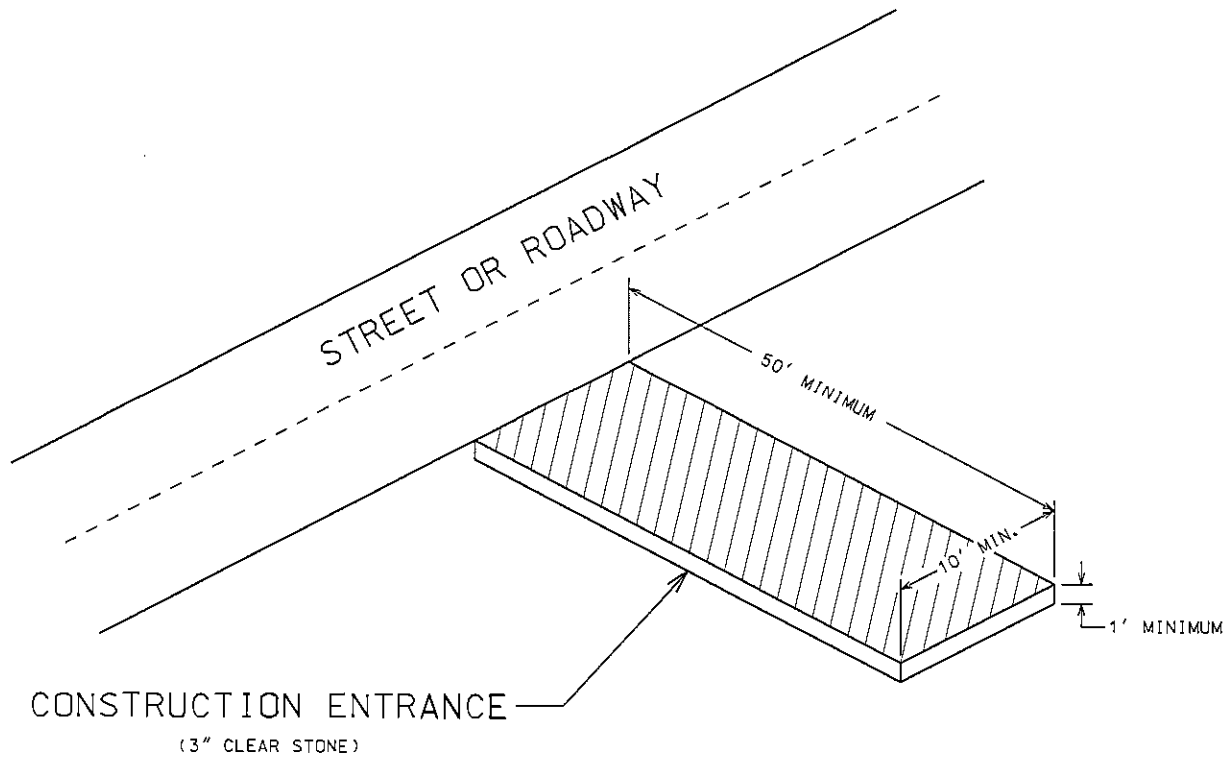

1.07

GENERAL NOTES:

1. CONSTRUCTION ENTRANCE TO BE INSTALLED PRIOR TO ANY TRAFFIC LEAVING THE SITE.
2. THE AGGREGATE FOR THE CONSTRUCTION ENTRANCE SHALL BE 3 INCH CLEAR OR WASHED STONE.
3. AGGREGATE SHALL BE PLACED IN A LAYER AT LEAST 12 INCHES THICK.
4. THE CONSTRUCTION ENTRANCE SHALL BE UNDERLAIN WITH A WDOT TYPE HR OR FF GEOTEXTILE FABRIC TO PREVENT MIGRATION OF UNDERLYING SOIL INTO THE STONE.
5. SURFACE WATERS MUST BE PREVENTED FROM PASSING THROUGH THE CONSTRUCTION ENTRANCE. FLOWS SHALL BE DIVERTED AWAY FROM THE CONSTRUCTION ENTRANCE OR CONVEYED UNDER AND AROUND THEM BY USE OF A CULVERT, DIVERSION BERM OR OTHER PRACTICES AS APPROVED BY THE CONSTRUCTION ENGINEER.
6. CLEANING BY SCRAPING OR ADDING NEW STONE SHALL BE REQUIRED IF ENTRANCE BECOMES MORE THAN 50% COVERED BY TRACKED MUD.

2012

CITY OF MADISON  
ENGINEERING DIVISION

CONSTRUCTION  
ENTRANCE

STANDARD DETAIL DRAWING 1.07

1.08

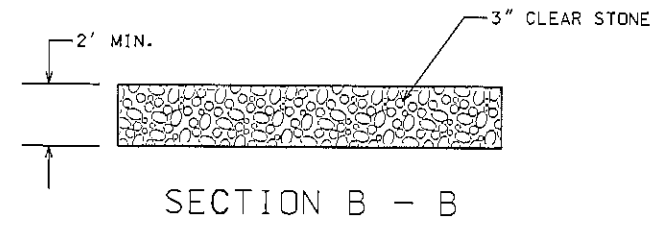
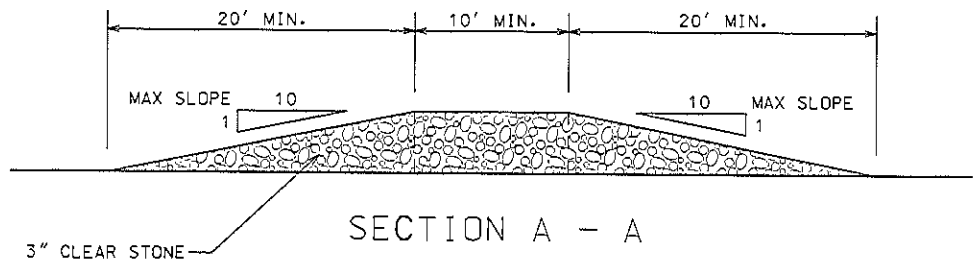
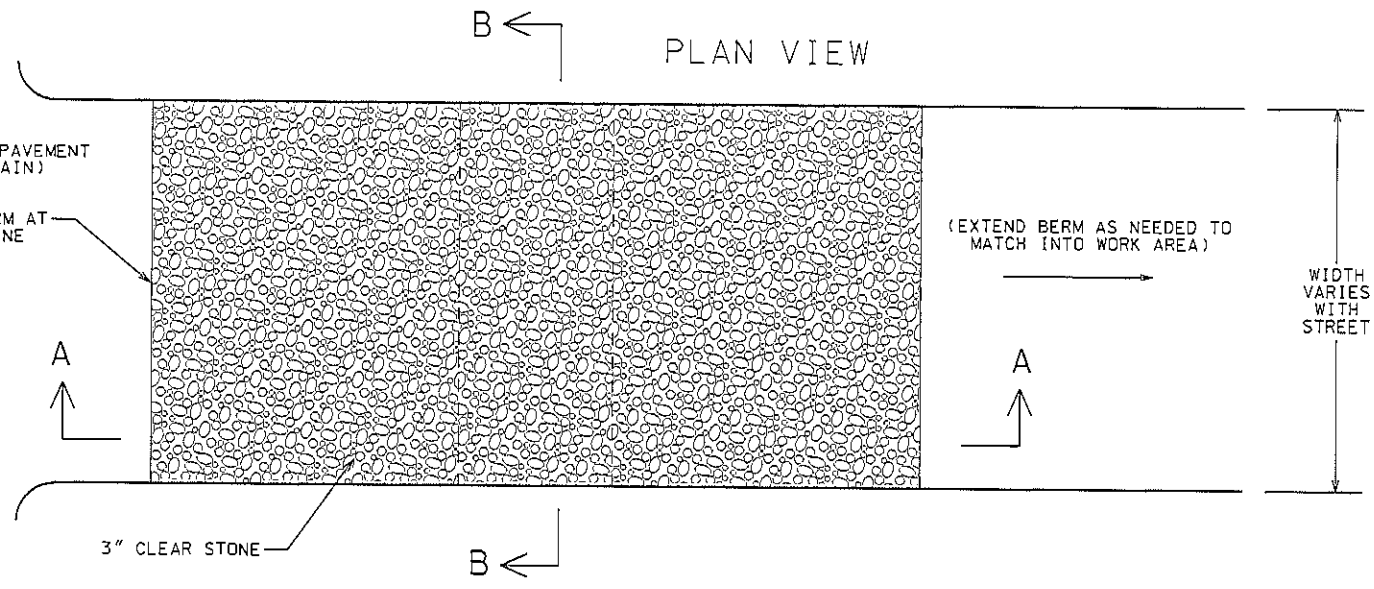

GENERAL NOTES:

1. THE STREET CONSTRUCTION ENTRANCE BERM IS TO BE INSTALLED PRIOR TO ANY TRAFFIC LEAVING THE SITE.
2. THE AGGREGATE FOR THE STREET CONSTRUCTION ENTRANCE BERM SHALL BE 3 INCH CLEAR OR WASHED STONE.
3. MINIMUM OVERALL LENGTH OF THE STREET CONSTRUCTION ENTRANCE BERM SHALL BE 50 FEET. THE BERM SHALL START AT THE SAWCUT LINE AND EXTEND INTO THE WORK AREA UNTIL IT MATCHES INTO THE WORK AREA GRADES.
4. THE MAXIMUM ALLOWABLE SLOPE OF 10:1 SHALL NOT BE EXCEEDED. THIS IS TO ALLOW EMERGENCY VEHICLE ACCESS TO THE CONSTRUCTION AREA WITHOUT NEEDING TO REMOVE THE BERM.
5. THE STREET CONSTRUCTION ENTRANCE BERM SHALL BE UNDERLAIN WITH A WDOT TYPE HR OR FF GEOTEXTILE FABRIC TO PREVENT MIGRATION OF UNERLYING SOIL INTO THE STONE.
6. CLEANING BY SCRAPING OR ADDING NEW STONE SHALL BE REQUIRED IF ENTRANCE BECOMES MORE THAN 50% COVERED BY TRACKED MUD.

2012
CITY OF MADISON ENGINEERING DIVISION
<b>STREET CONSTRUCTION ENTRANCE BERM</b>
STANDARD DETAIL DRAWING 1.08

# SILT SOCK (NTS)

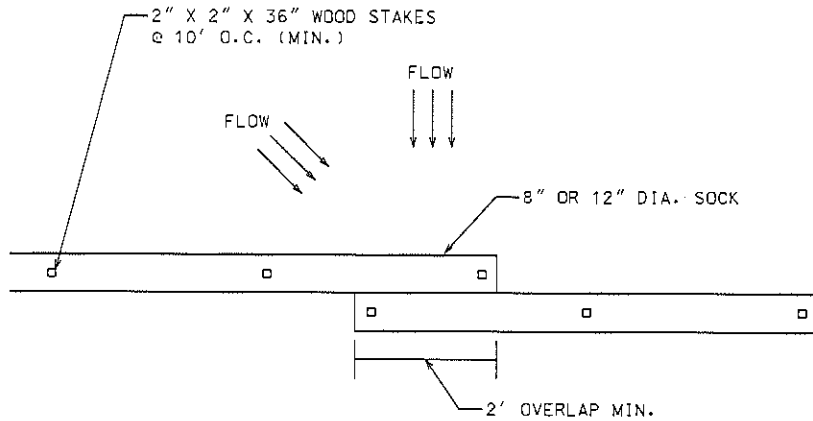

PLAN VIEW - FLOW 45 TO 90 DEG. TO SOCK

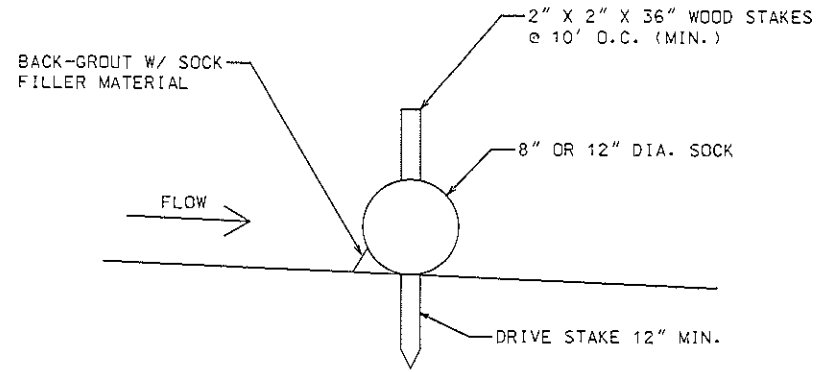

SECTION VIEW

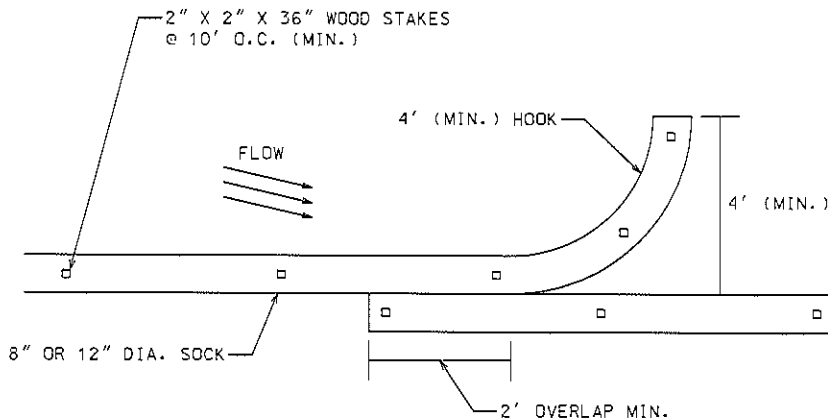

PLAN VIEW - FLOW LESS THAN 45 DEG. TO SOCK

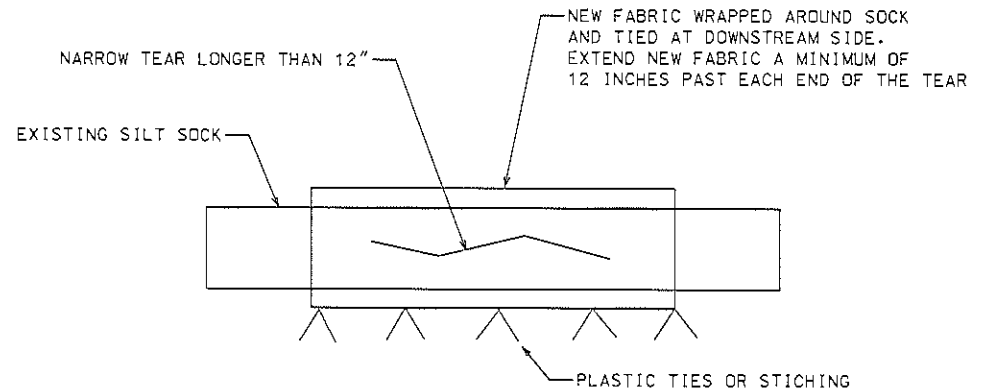

REPAIR DETAIL - TEAR GREATER THAN 12 INCHES

GENERAL NOTES:

1. SOCK MATERIAL PER STANDARD SPECIFICATIONS. SILT SOCK FILLER SHALL BE COMPOST OR WOOD CHIPS (2" MAX.)
2. WHEN SILT SOCK IS USED ON A PAVED SURFACE CONCRETE BLOCKS SHALL BE USED TO SECURE SILT SOCK IN PLACE OF STAKING
3. ACCUMULATED SEDIMENT SHALL BE REMOVED FROM BEHIND THE SILT SOCK WHEN IT HAS REACHED A HEIGHT EQUAL TO HALF OF THE SOCK HEIGHT.
4. SMALL HOLES OR NARROW RIPS LESS THAN 12' LONG MAY BE STICHED CLOSED USING PLASTIC ZIP TIES. LARGER RIPS SHALL BE FIXED PER THE REPAIR DETAIL. HEAVILY DAMAGED SECTIONS SHALL BE REPLACED ENTIRELY. MAINTAIN 2' MINIMUM OVERLAP AT EACH END.
5. 8" OR 12" DIAMETER SOCK AS SPECIFIED IN THE EROSION CONTROL PLAN OR AS DIRECTED BY THE CONSTRUCTION ENGINEER.

CITY OF MADISON  
ENGINEERING DIVISION

SILT SOCK

STANDARD DETAIL DRAWING 1.09

2012

1.09

1.10

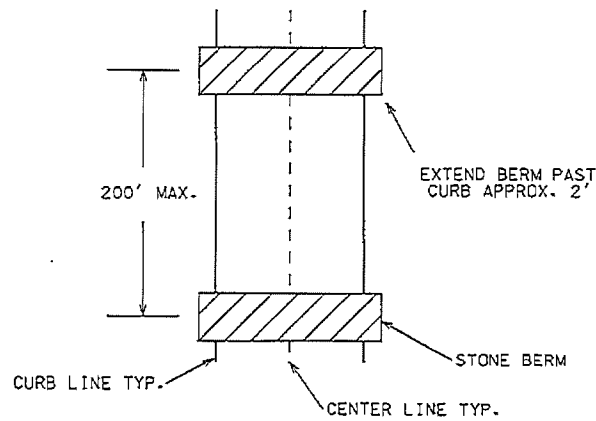

FULL WIDTH SPACING

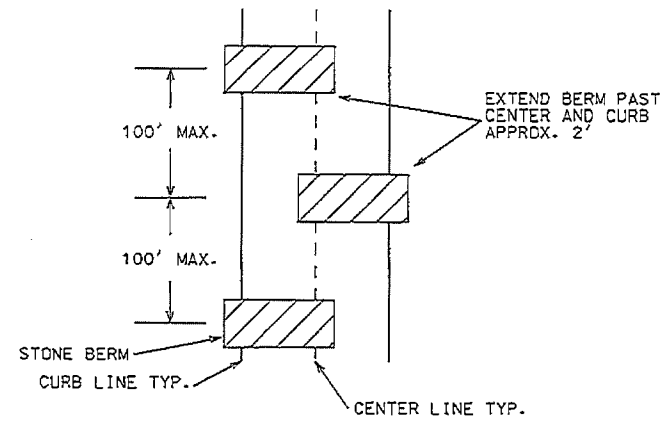

STAGGERED SPACING

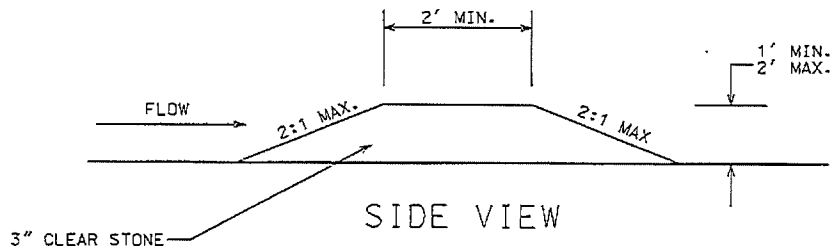

SIDE VIEW

GENERAL NOTES:

1. THE STREET CONSTRUCTION STONE BERM IS NOT INTENDED FOR USE ON STREETS WITH GREATER THAN 6 PERCENT SLOPES.
2. THE AGGREGATE FOR THE STREET CONSTRUCTION STONE BERM SHALL BE 3 INCH CLEAR OR WASHED STONE.
3. MINIMUM OVERALL LENGTH OF THE STREET CONSTRUCTION STONE BERM WILL BE DICTATED BY THE WIDTH OF THE EXISTING OR PROPOSED STREET.
4. SPACING OF STREET CONSTRUCTION STONE BERMS SHALL BE PER THE APPROVED EROSION CONTROL IMPLEMENTATION PLAN. FOR PROJECTS WITHOUT AN EROSION CONTROL IMPLEMENTATION PLAN SPACING SHALL BE AS NOTED ABOVE.

2011

CITY OF MADISON  
ENGINEERING DIVISION

STREET CONSTRUCTION  
STONE BERM

STANDARD DETAIL DRAWING 1.10



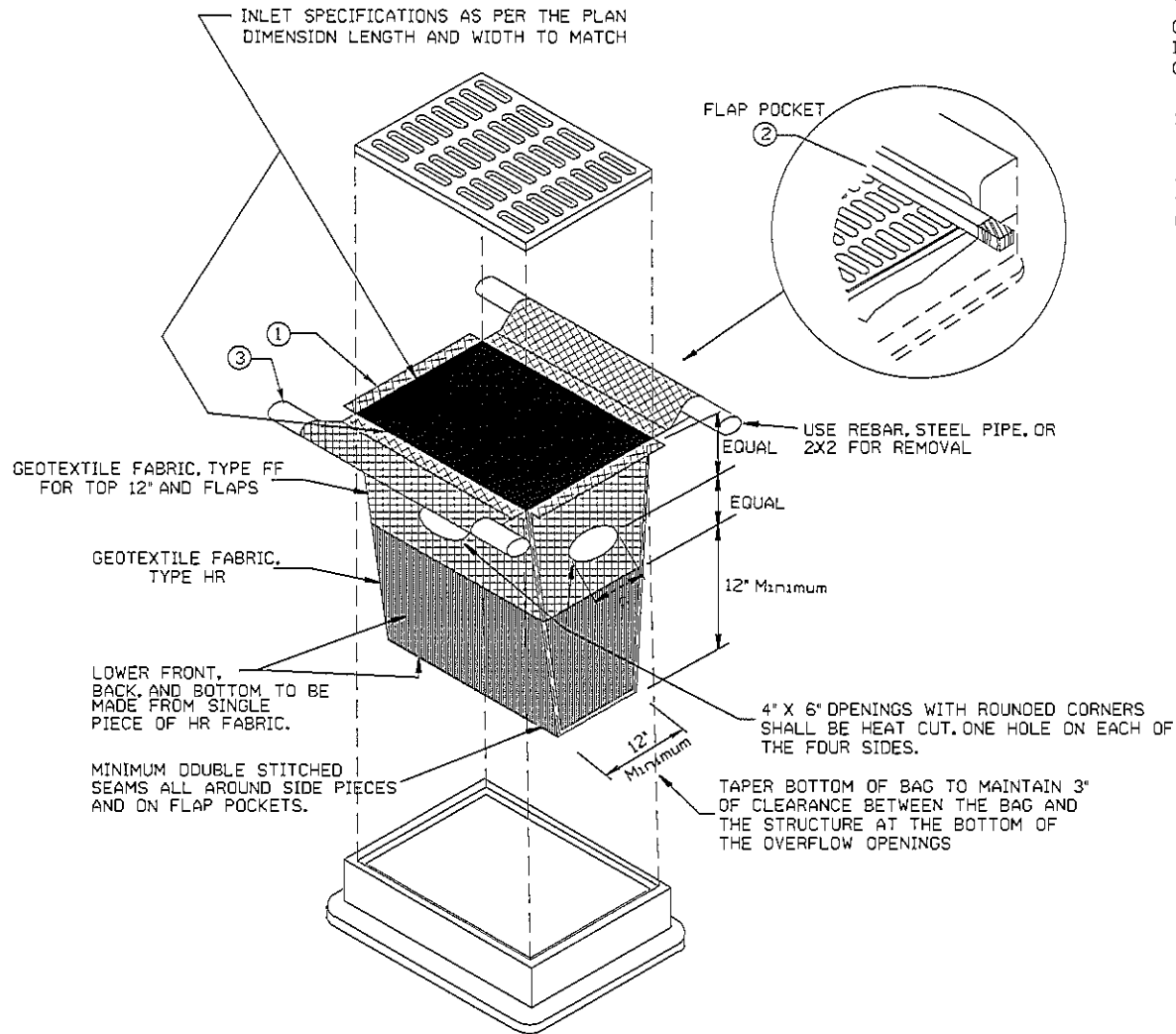

**GENERAL NOTES**

CLEANING SHALL BE REQUIRED WHEN SEDIMENT OR STANDING WATER IS WITHIN 6' OF THE OVERFLOW HOLES OR AS DIRECTED BY THE CONSTRUCTION ENGINEER.

WHEN REMOVING OR MAINTAINING INLET PROTECTION, CARE SHALL BE TAKEN SO THAT THE SEDIMENT TRAPPED ON THE GEOTEXTILE FABRIC DOES NOT FALL INTO THE INLET. ANY MATERIAL FALLING INTO THE INLET SHALL BE REMOVED IMMEDIATELY.

THE INSTALLED BAG SHALL HAVE A MINIMUM SIDE CLEARANCE, BETWEEN THE INLET WALLS AND THE BAG, MEASURED AT THE BOTTOM OF THE OVERFLOW HOLES, OF 3".

- ① SIDE FLAPS SHALL BE A MAXIMUM OF 2' LONG. FOLD THE FABRIC OVER AND REINFORCE WITH MULTIPLE STICHES. FLAP POCKETS SHALL BE LARGE ENOUGH TO
- ② ACCEPT WOOD 2X2. THE 2X2 SHALL BE INSTALLED IN THE REAR FLAP AND SHALL NOT BLOCK THE TOP HALF OF THE CURB FACE OPENING.
- ③ FRONT LIFTING FLAP IS TO BE USED WHEN REMOVING AND MAINTAINING FILTER BAG.

CITY OF MADISON  
ENGINEERING DIVISION

INLET PROTECTION  
TYPE D  
HYBRID

STANDARD DETAIL DRAWING 1.11

Single, straight, main trunk.  
Lower branches may require  
removal for height clearance

Remove transit guard

Root flare to be level  
with the finished grade

3"-4" of woody mulch:  
Shredded or Ground  
hardwood bark mulch

Remove wire baskets; or cut top and  
fold down in pit after positioned for  
backfill planting. Cut and remove or  
fold down burlap from upper 1/2  
of ball.

Cut and remove all poly ties and burlap !!

Water thoroughly to eliminate air pockets,  
and to settle the surrounding soil

Finish Grade

Soil under ball undisturbed  
to support root ball  
and reduce settling

Break down sides of  
hole when backfilling

3 times ball diameter

Backfill: Excavated soil or amended  
as specified. Do Not Tamp !!!

2004

CITY OF MADISON  
PARKS DIVISION

STANDARD PLANTING  
TECHNIQUE FOR TREES  
IN TURF AREAS

STANDARD DETAIL DRAWING 2.01

Single, straight, main trunk.  
Lower branches may require  
removal for height clearance

Remove transit guard

Root flare to be  
at the soil grade

Tree Grate as specified for project

Remove wire baskets; or cut top and  
fold down in pit after positioned for  
backfill planting. Cut and remove or  
fold down burlap from upper 1/2  
of ball.

5"-6" of #2 Washed Stone

Cut and remove all poly ties and burlap !!

Water thoroughly to eliminate air pockets,  
and to settle the surrounding soil

Landscape Fabric to be 6 oz.  
non-woven permeable

Finish Concrete Grade

Subgrade:

Compacted sand/gravel

#2 Washed Stone Mulch

Soil under ball undisturbed  
to support root ball  
and reduce settling

Soil Grade

3 times ball diameter  
(if sidewalk opening allows)

Backfill: Granular Topsoil or amended  
as specified. Do Not Tamp !!!

2004

CITY OF MADISON  
PARKS DIVISION

STANDARD PLANTING  
TECHNIQUE FOR TREES  
IN TREE GRATES

STANDARD DETAIL DRAWING 2.02

Branching to be full throughout entire tree/shrub as is typical from the species.  
Any broken branches to be removed

Single, straight, main trunk.  
Lower branches may require removal for height clearance  
(when / where applicable / specified)

Root flare to be level with the finished grade

3"-4" of woody mulch:  
Shredded or Ground hardwood bark mulch  
(over landscape fabric when/where specified)

Remove wire baskets; or cut top and fold down in pit after positioned for backfill planting. Cut and remove or fold down burlap from upper 1/2 of ball.  
Cut and remove all poly ties and burlap !!  
- or -  
Remove Poly Pot and dispose

Water thoroughly to eliminate air pockets, and to settle the surrounding soil

Finish Grade

Soil under ball undisturbed to support root ball and reduce settling

Break down sides of hole when backfilling

3 times ball diameter

Backfill: Excavated soil or amended as specified. Do Not Tamp !!!

2004

CITY OF MADISON  
PARKS DIVISION

STANDARD PLANTING  
TECHNIQUE FOR  
EVERGREENS

STANDARD DETAIL DRAWING 2.03

Branching to be full throughout entire tree/shrub as is typical from the species.  
Any broken branches to be removed

Single, straight, main trunk.  
Lower branches may require removal for height clearance  
(when / where applicable / specified)

3"-4" of woody mulch:  
Shredded or Ground  
hardwood bark mulch  
(over landscape fabric  
when/where specified)

Root flare to be level  
with the finished grade

Remove wire baskets; or cut top and  
fold down in pit after positioned for  
backfill planting. Cut and remove or  
fold down burlap from upper 1/2  
of ball.

Cut and remove all poly ties and burlap !!

- or -

Remove Poly Pot and dispose

Water thoroughly to eliminate air pockets,  
and to settle the surrounding soil

Finish Grade

Soil under ball undisturbed  
to support root ball  
and reduce settling

Break down sides of  
hole when backfilling

3 times ball diameter

Backfill: Excavated soil or amended  
as specified. Do Not Tamp !!!

2004

CITY OF MADISON  
PARKS DIVISION

## STANDARD PLANTING TECHNIQUE FOR SHRUBS

STANDARD DETAIL DRAWING 2.04

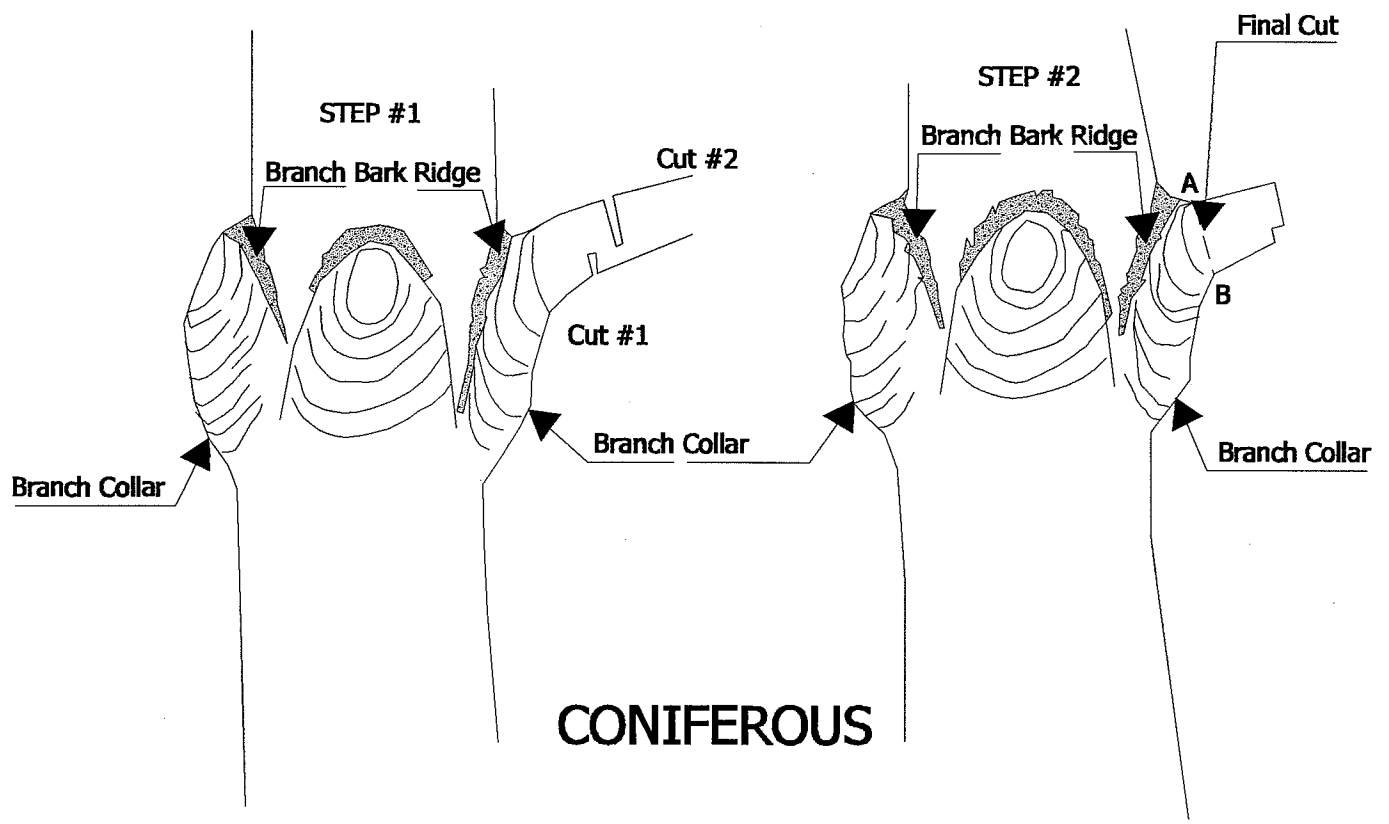
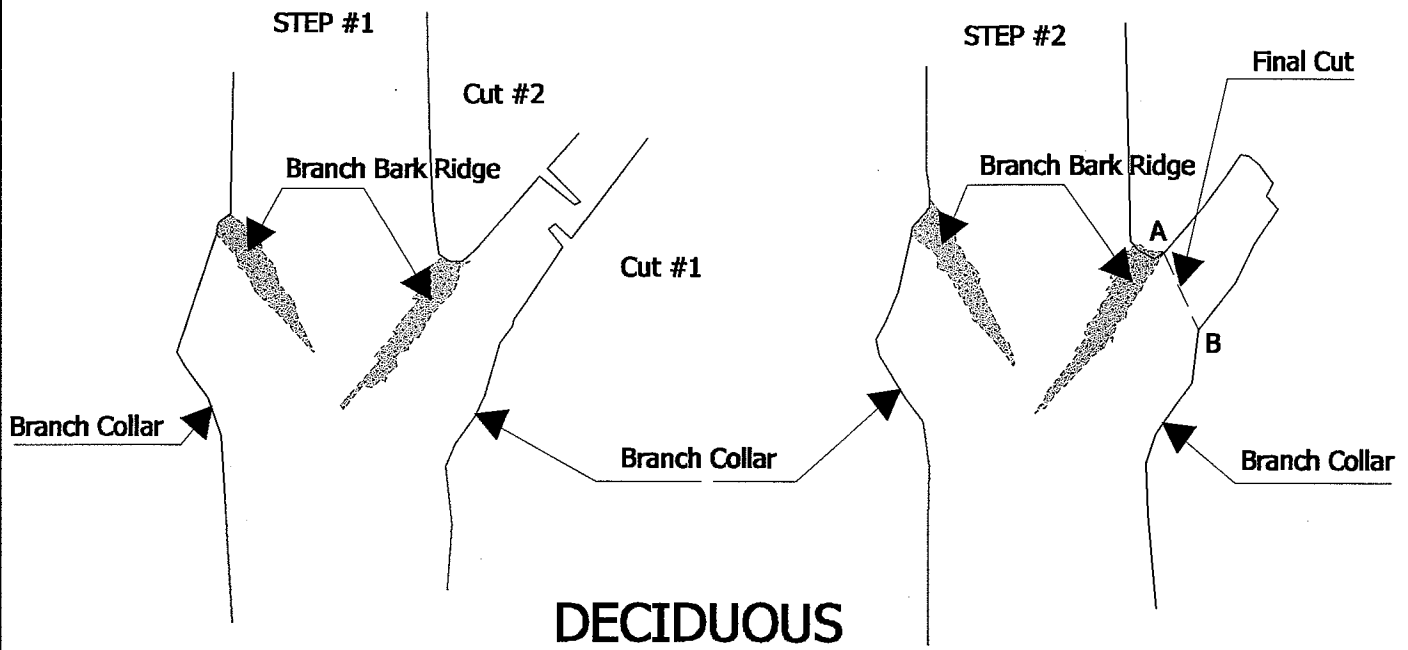

- 1)-Step #1 - This 2 cut process reduces the likelihood that the limb will peel and cause additional unwanted tissue damage
- 2)-Step #2 - Your finish or final cut should be made from Point A to Point B:  
**DO NOT LEAVE STUBS & DO NOT FLUSH CUT**
- NOTE: DO NOT CUT INTO THE BRANCH BARK RIDGE**  
**DO NOT REMOVE THE BRANCH COLLAR**

2004

CITY OF MADISON PARKS DIVISION
STANDARD PRUNING TECHNIQUES FOR DECIDUOUS AND CONIFEROUS TREES AND SHRUBS
STANDARD DETAIL DRAWING 2.05

2.06

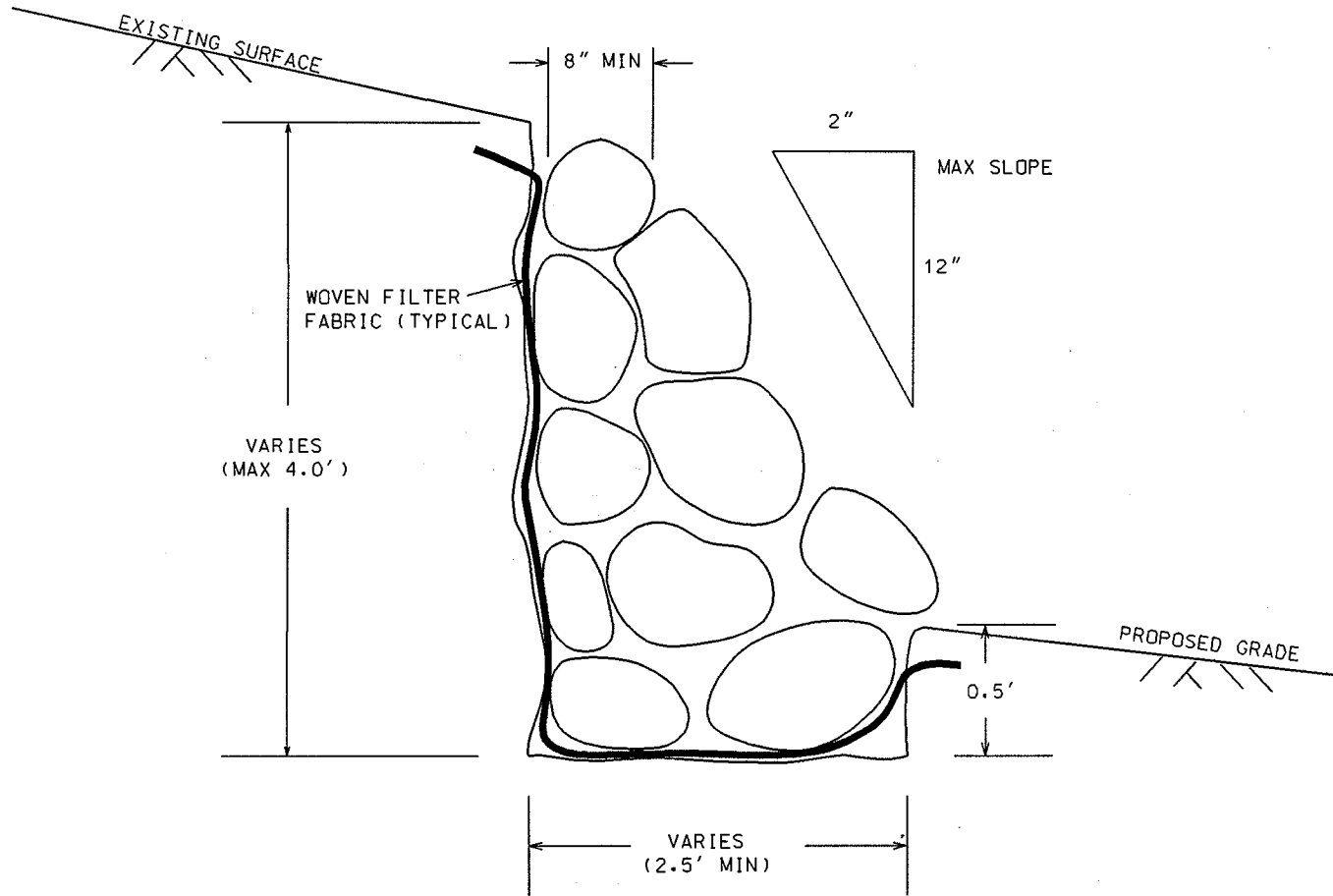

NOTE: FILTER FABRIC TO BE  
PLACED BEHIND WALL  
UNLESS OTHERWISE SPECIFIED

2004

CITY OF MADISON  
ENGINEERING DIVISION

TYPICAL FIELD STONE  
RETAINING WALL

DRAWING NOT TO SCALE

STANDARD DETAIL DRAWING 2.06

TOP VIEW

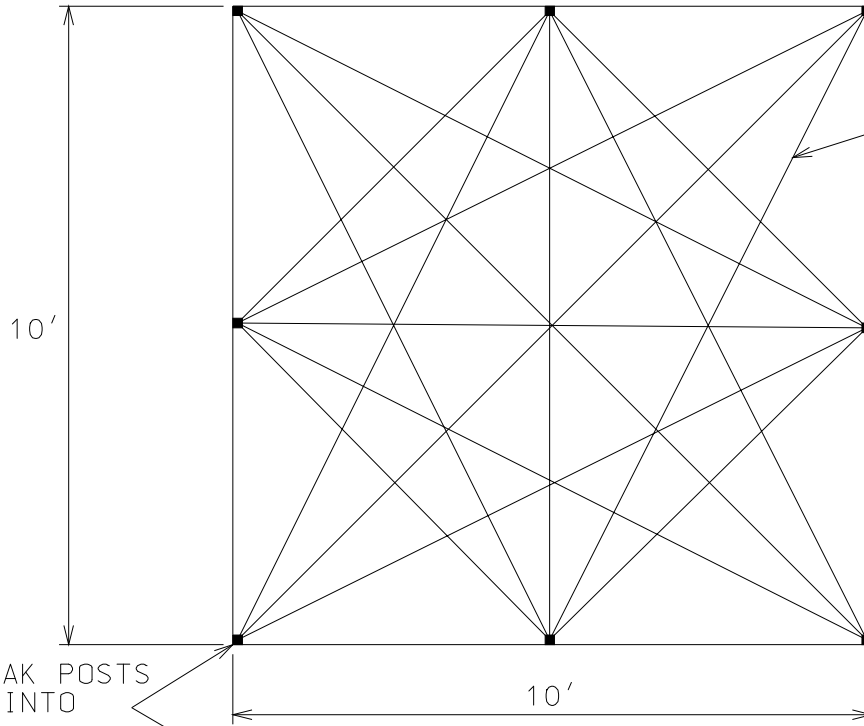

1/8" MIN O.D. POLYTWINE  
(YELLOW OR WHITE) PLACED  
IN PATTERN AS SHOWN AND  
ANCHORED SECURELY TO POSTS

2"X2"X6' (MIN) OAK POSTS  
DRIVEN 3' (MIN) INTO  
EXISTING GROUND

2"X4" WELDED WIRE  
MESH (3' HIGH) ANCHORED  
SECURELY TO POSTS

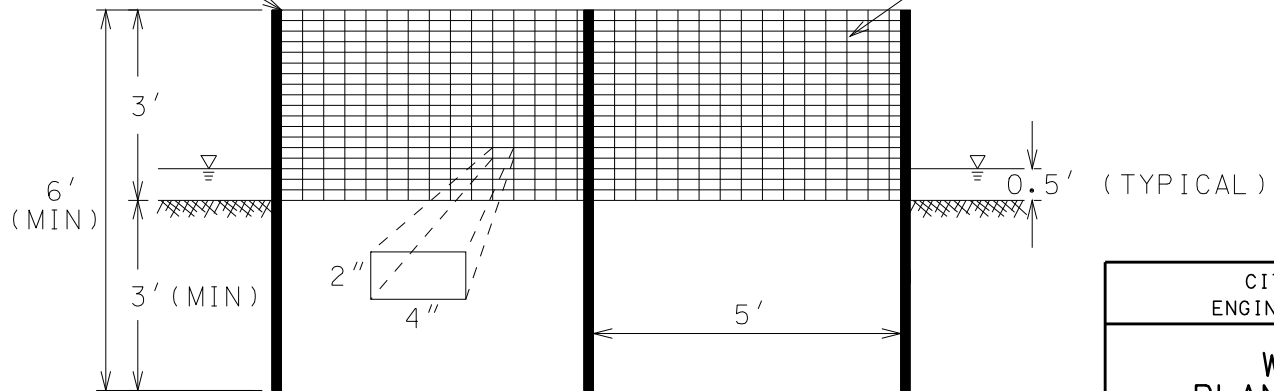

FRONT VIEW

2005

CITY OF MADISON  
ENGINEERING DIVISION

WETLAND  
PLANTING PODS  
TYPE #1

STANDARD DETAIL DRAWING 2.07

2.07



TOP VIEW

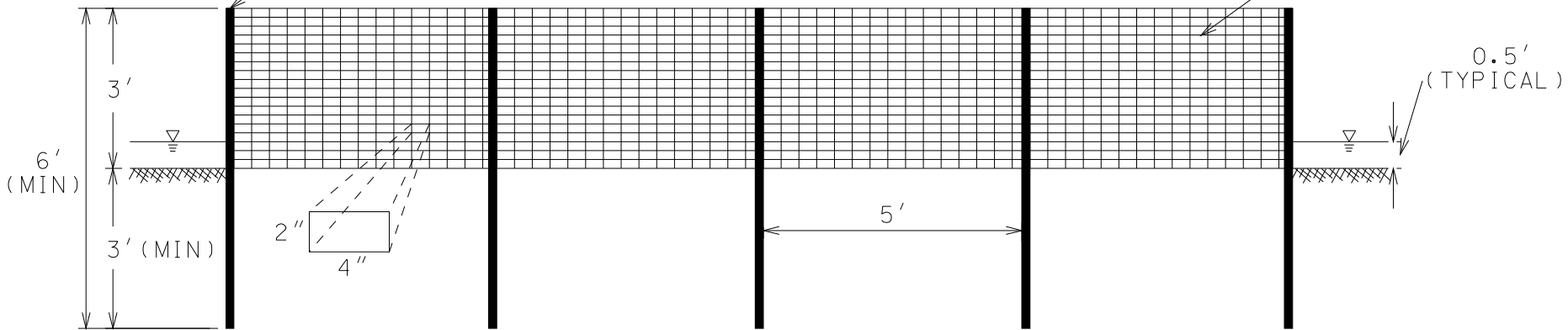
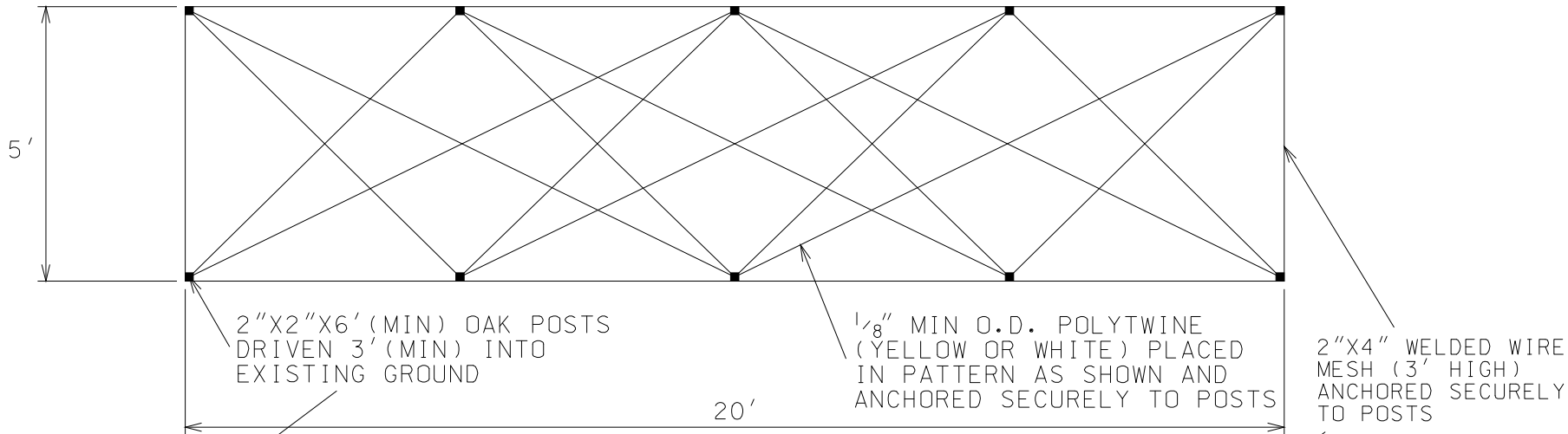

FRONT VIEW

2005

CITY OF MADISON ENGINEERING DIVISION
<b>WETLAND PLANTING PODS TYPE #2</b>
STANDARD DETAIL DRAWING 2.08

2.08

# RAINGARDEN TYPICAL DETAIL

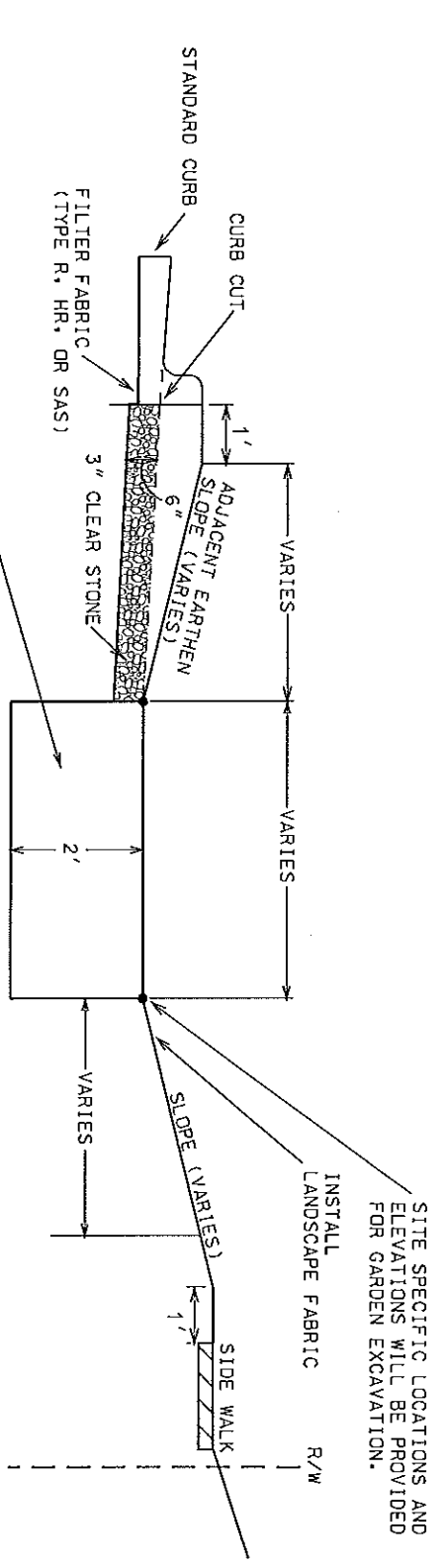

ENGINEERED SOIL  
 45-55% PREWASHED COARSE SILICA SAND  
 10-15% USDA SANDY LOAM, LOAMY SAND,  
 OR LOAM TOPSOIL  
 30-50% COMPOST—PER SPECIAL PROVISIONS

SITE SPECIFIC LOCATIONS AND ELEVATIONS WILL BE PROVIDED FOR GARDEN EXCAVATION.

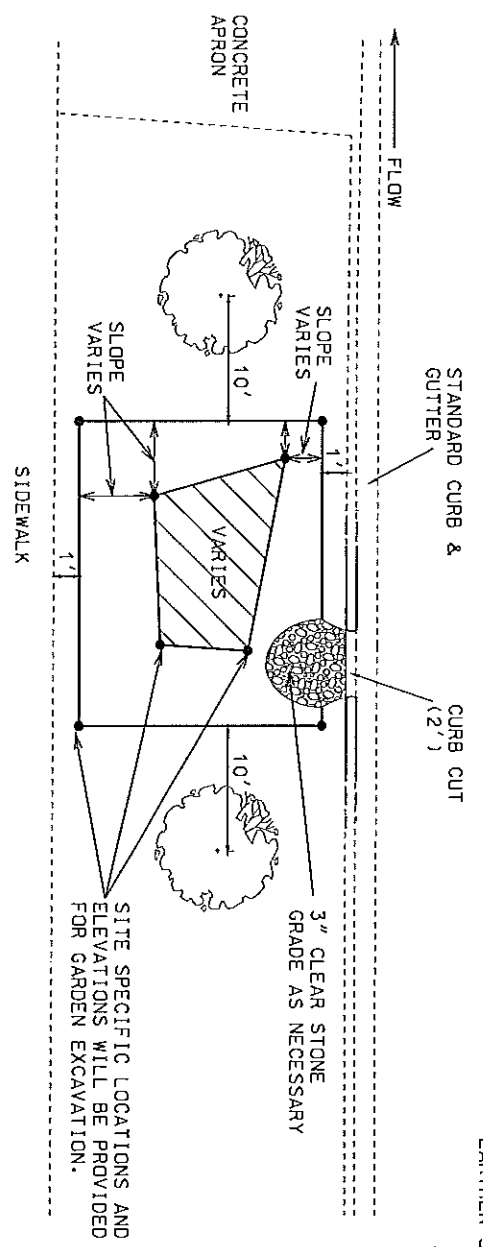
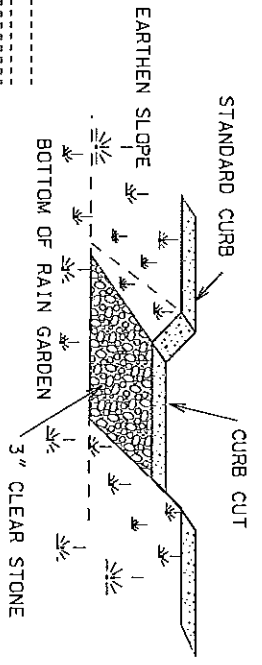

CITY OF MADISON
ENGINEERING DIVISION
2013
RAINGARDEN DETAIL
STANDARD DETAIL DRAWING 2.09

3.01

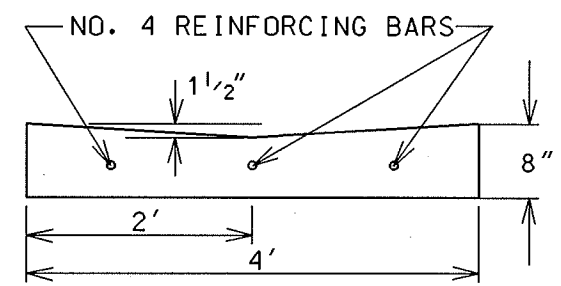
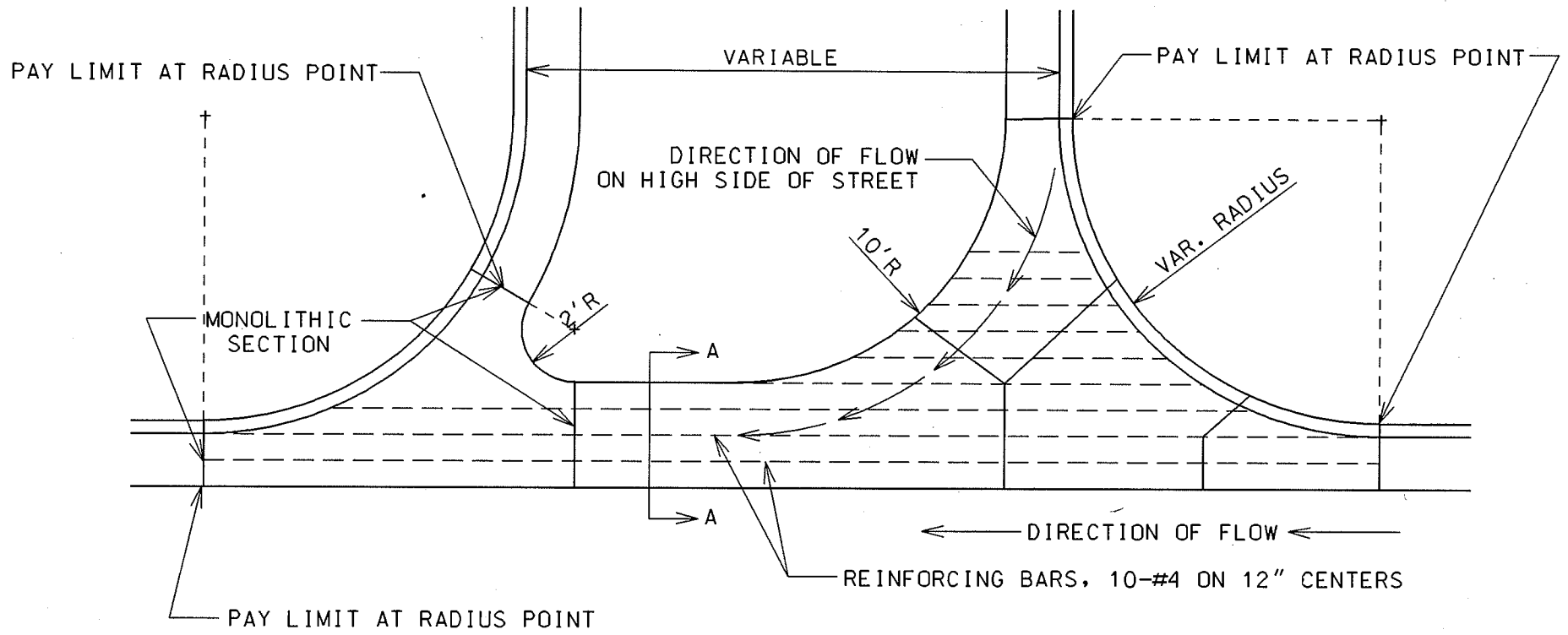

SECTION A-A

GENERAL NOTES:

SPECIAL WATERWAY DETAIL SHALL BE USED WHEN SPECIFIED ON THE PLAN IN LIEU OF A SLOPE GUTTER AT STREET INTERSECTIONS

SPECIAL WATERWAY SHALL BE MEASURED AND PAID FOR BY THE SQUARE FOOT

REINFORCING BARS SHALL BE EPOXY COATED AND INSTALLED IN THE SPECIAL WATERWAY AS SHOWN AND SHALL BE INCIDENTAL TO THE SPECIAL WATERWAY

2004

CITY OF MADISON  
ENGINEERING DIVISION

STANDARD  
SPECIAL WATERWAY

STANDARD DETAIL DRAWING 3.01

RESIDENTIAL

COMMERCIAL

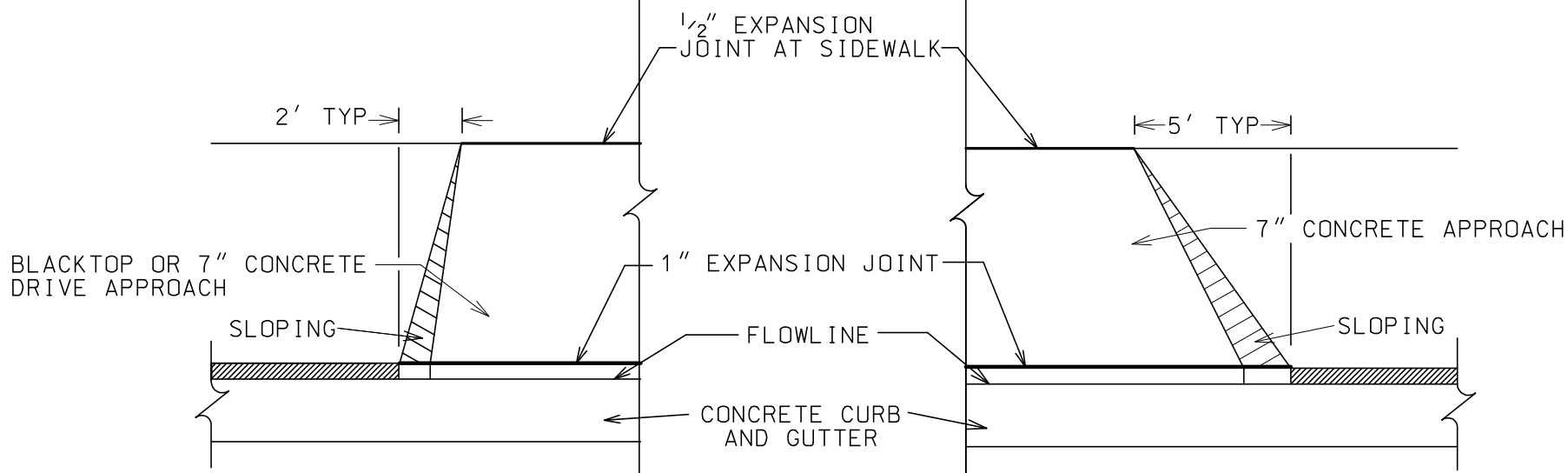

EXPANSION JOINTS IN ACCORDANCE WITH REQUIREMENTS OF 302.2d and 303.2d

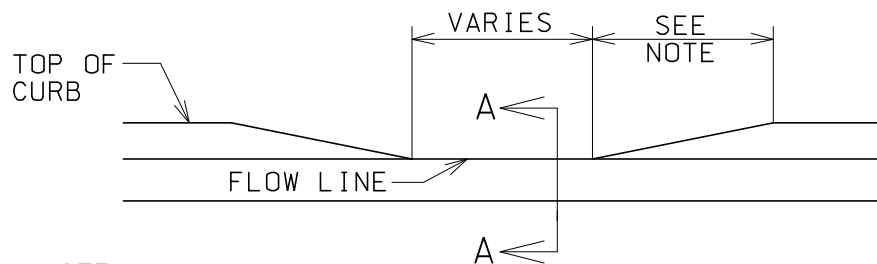

NOTE:  
12" TO 18" TAPER FOR STANDARD DRIVEWAY APPROACH  
18" TO 24" TAPER FOR STANDARD RAMP

TYPICAL CURB CUT TAPER

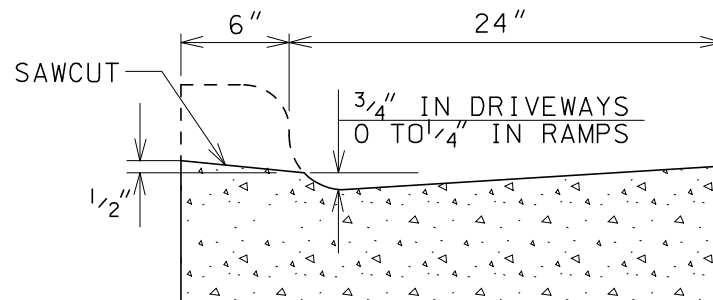

DRIVEWAY SECTION TYPE 'A'  
CONCRETE CURB & GUTTER

SECTION A-A

GENERAL NOTE:

IF THE CURB CUT IS NOT CONSTRUCTED WITH THE INITIAL CURB AND GUTTER CONSTRUCTION, THE CURB CUT CAN BE MADE BY REMOVING AND REPLACING THE ENTIRE CURB AND GUTTER SECTION OR BY SAWCUTTING THE EXISTING CURB HEAD BY MEANS OF A SPECIAL SAW DESIGNED TO MEET THE DETAILS ABOVE FOR MADISON STANDARD CURB CUTS.

ALL EXPANSION JOINTS SHALL EXTEND THROUGH THE ENTIRE THICKNESS OF THE APPROACH OR SIDEWALK, WHICHEVER IS THICKER.

2007

CITY OF MADISON  
ENGINEERING DIVISION

MADISON STANDARD  
CURB CUT DETAILS

STANDARD DETAIL DRAWING 3.02

3.02

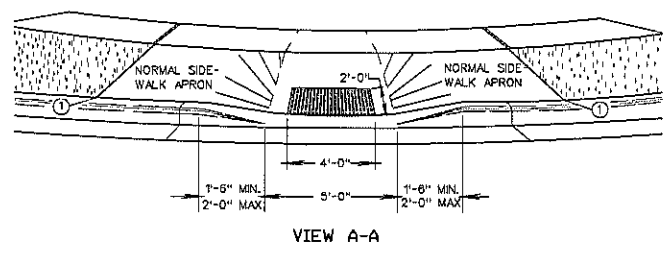
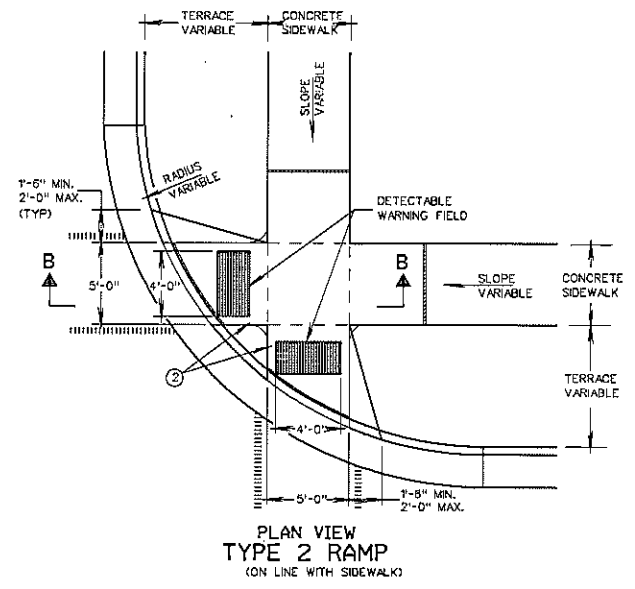
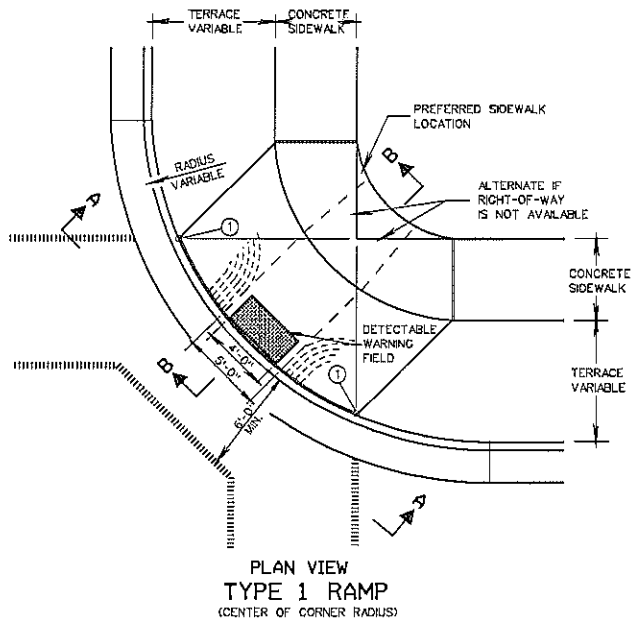

2009

CITY OF MADISON  
ENGINEERING DIVISION

---

**STANDARD CURB RAMPS  
TYPES 1 AND 2**

---

STANDARD DETAIL DRAWING 3.03

NOTE: MATERIALS AND METHOD OF CONSTRUCTION FOR TRUNCATED DDMES SHALL BE SPECIFIED IN SPECIAL PROVISIONS OR AS REQUIRED BY THE CITY ENGINEER

**GENERAL NOTES**

- TYPE 2-A RAMPS SHALL BE USED IN NEW DEVELOPMENTS UNLESS OTHERWISE APPROVED BY THE CITY ENGINEER.
  - DETAILS OF CONSTRUCTION, MATERIALS AND WORKMANSHIP NOT SHOWN ON THIS DRAWING SHALL CONFORM TO THE PERTINENT REQUIREMENTS OF THE STANDARD SPECIFICATIONS AND THE APPLICABLE SPECIAL PROVISIONS.
  - RAMPS SHALL BE BUILT AT 12H:1V OR FLATTER. WHEN NECESSARY, THE SIDEWALK ELEVATION MAY BE LOWERED TO MEET THE HIGH POINT ON THE RAMP.
  - DETECTABLE WARNING FIELD SHALL BE MEASURED AND PAID BY THE SQUARE FOOT AS "CURB RAMP DETECTABLE WARNING FIELD".
  - CURB RAMP DETECTABLE WARNING FIELD MATERIALS AND DEVICES SHALL BE APPROVED BY THE CITY ENGINEER. THE COLOR OF THE DETECTABLE WARNING FIELD SHALL BE SAFETY YELLOW OR APPROVED EQUAL AND IS INCIDENTAL TO THE BID ITEM OF "CURB RAMP DETECTABLE WARNING FIELD".
  - SURFACE TEXTURE OF THE RAMP SHALL BE OBTAINED BY COARSE BROOMING TRANSVERSE TO THE SLOPE OF THE RAMP.
  - THE DETECTABLE WARNING SURFACE SHALL BE LOCATED SO THAT THE EDGE NEAREST THE CURB LINE IS 6 INCHES MINIMUM AND 8 INCHES MAXIMUM FROM THE CURB LINE.
- ① THIS POINT IS AN EXTENSION OF OUTSIDE EDGE OF APPROACHING SIDEWALK WHERE IT MEETS THE BACK OF CONCRETE CURB.
- ② WHEN THIS DISTANCE IS LESS THAN 6'-0" IT MAY BE DIFFICULT TO ACHIEVE A 12H:1V SLOPE, OR FLATTER, ON THE RAMP. REDUCE CURB HEIGHT IN TRIANGLE AREA TO ACHIEVE 12H:1V SLOPE, OR FLATTER, ON RAMP. 2" MINIMUM CURB HEIGHT.

- LEGEND**
- 1" EXPANSION JOINT-SIDEWALK
  - - - - - CONTRACTION JOINT FIELD LOCATED
  - ||||| PAVEMENT MARKING, WHITE, 6-INCH
  - ALTERNATIVE LAYOUT

# GENERAL NOTES

TYPE 2-A RAMPS SHALL BE USED IN NEW DEVELOPMENT UNLESS OTHERWISE APPROVED BY THE CITY ENGINEER

DETAILS OF CONSTRUCTION, MATERIALS AND WORKMANSHIP NOT SHOWN ON THIS DRAWING SHALL CONFORM TO THE PERTINENT REQUIREMENTS OF THE STANDARD SPECIFICATIONS AND THE APPLICABLE SPECIAL PROVISIONS.

RAMPS SHALL BE BUILT AT 12H:1V OR FLATTER, WHEN NECESSARY, THE SIDEWALK ELEVATION MAY BE LOWERED TO MEET THE HIGH POINT ON THE RAMP.

DETECTABLE WARNING FIELD SHALL BE MEASURED AND PAID BY THE SQUARE FOOT AS "CURB RAMP DETECTABLE WARNING FIELD".

CURB RAMP DETECTABLE WARNING FIELD MATERIALS AND DEVICES SHALL BE APPROVED BY THE CITY ENGINEER. THE COLOR OF THE DETECTABLE WARNING FIELD SHALL BE SAFETY YELLOW OR APPROVED EQUAL AND IS INCIDENTAL TO THE BID ITEM OF "CURB RAMP DETECTABLE WARNING FIELD".

SURFACE TEXTURE OF THE RAMP SHALL BE OBTAINED BY COARSE BROOMING TRANSVERSE TO THE SLOPE OF THE RAMP.

THE DETECTABLE WARNING SURFACE SHALL BE LOCATED SO THAT THE EDGE NEAREST THE CURB LINE IS 6 INCHES MINIMUM AND 8 INCHES MAXIMUM FROM THE CURB LINE.

- ① THIS POINT IS AN EXTENSION OF OUTSIDE EDGE OF APPROACHING SIDEWALK WHERE IT MEETS THE BACK OF CONCRETE CURB.
- ② WHEN THIS DISTANCE IS LESS THAN 8'-0" IT MAY BE DIFFICULT TO ACHIEVE A 12H:1V SLOPE, OR FLATTER, ON THE RAMP. REDUCE CURB HEIGHT IN TRIANGLE AREA TO ACHIEVE 12H:1V SLOPE, OR FLATTER, ON RAMP. 2" MINIMUM CURB HEIGHT.

## LEGEND

- ===== 1" EXPANSION JOINT-SIDEWALK
- - - - - CONTRACTION JOINT FIELD LOCATED
- ||||||| PAVEMENT MARKING CROSSWALK (WHITE)
- \_\_\_\_\_ ALTERNATIVE LAYOUT

3.04

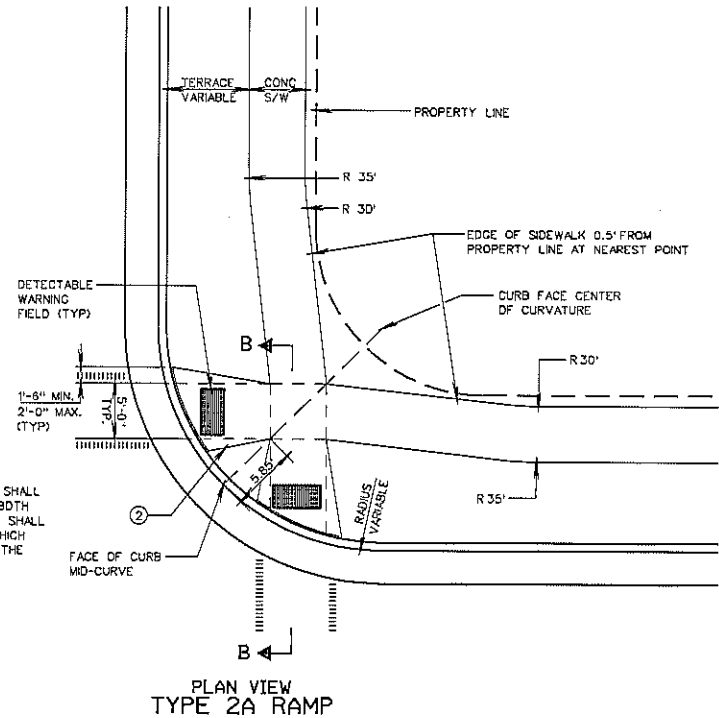

	MIN.	MAX.
A	1.6"	2.4"
B	0.85"	1.5"
C	*	*
D	0.9"	1.4"

\* THE C DIMENSION IS 50% TO 65% OF THE D DIMENSION.

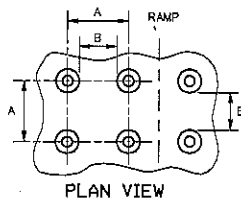

TRUNCATED DOMES  
DETECTABLE WARNING  
PATTERN DETAIL

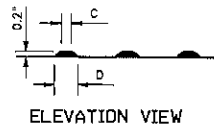

ELEVATION VIEW

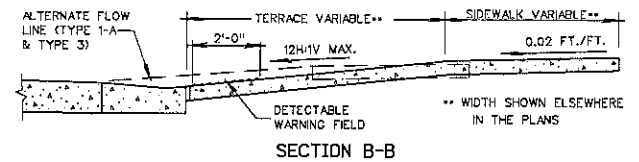

SECTION B-B

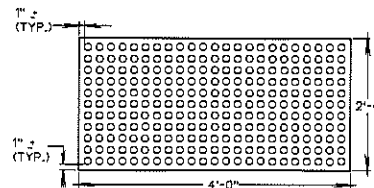

PLAN VIEW  
DETECTABLE WARNING  
FIELD (TYPICAL)

NOTE: MATERIALS AND METHOD OF CONSTRUCTION FOR TRUNCATED DOMES SHALL BE SPECIFIED IN SPECIAL PROVISIONS OR AS REQUIRED BY THE CITY ENGINEER

2009

CITY OF MADISON  
ENGINEERING DIVISION

CURB RAMPS GENERAL  
AND  
CURB RAMP TYPE 2-A

STANDARD DETAIL DRAWING 3.04

3.05

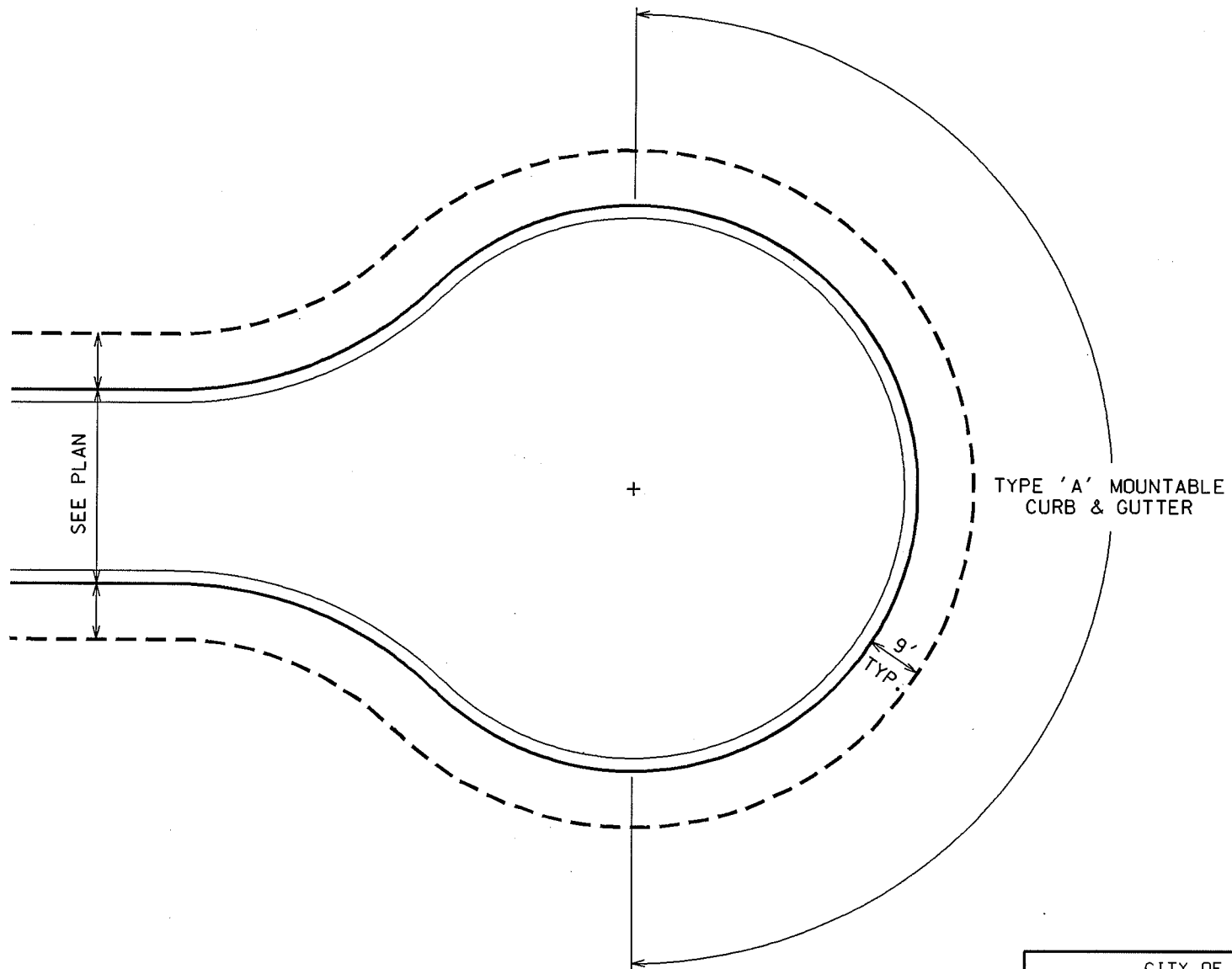

2004

CITY OF MADISON  
ENGINEERING DIVISION

**CURB & GUTTER  
DETAIL AT END  
OF CUL-DE-SAC**

STANDARD DETAIL DRAWING 3.05

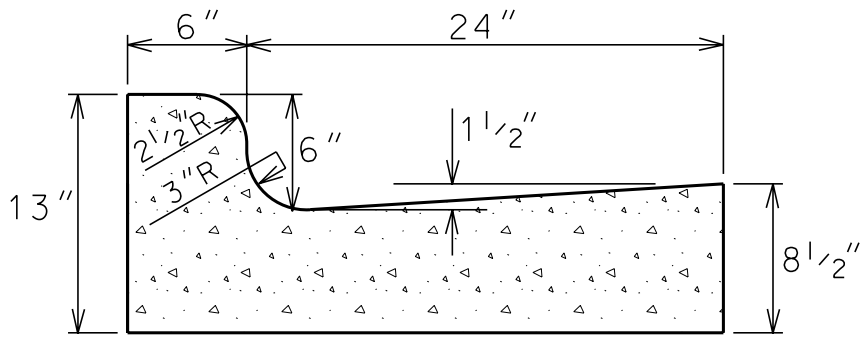

**TYPE 'A' CONCRETE CURB & GUTTER**

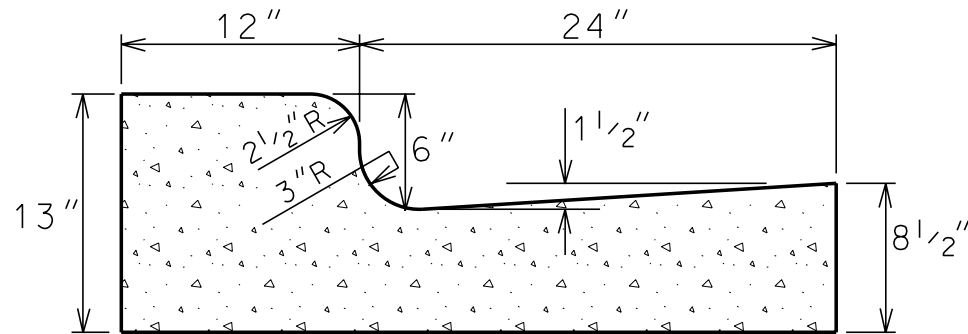

**TYPE 'B' CONCRETE CURB & GUTTER**

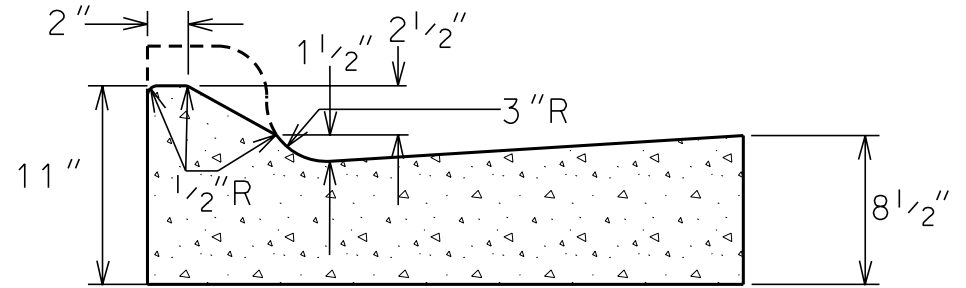

**TYPE 'A' MOUNTABLE CONCRETE CURB & GUTTER  
(PAY AS TYPE 'A' CURB AND GUTTER)**

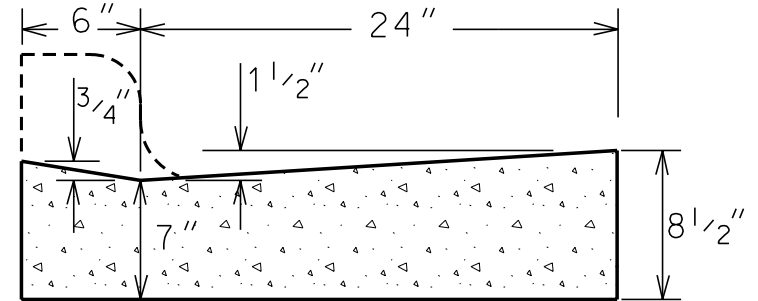

**DRIVEWAY SECTION TYPE 'A' CURB & GUTTER  
(PAY AS TYPE 'A' CURB AND GUTTER)**

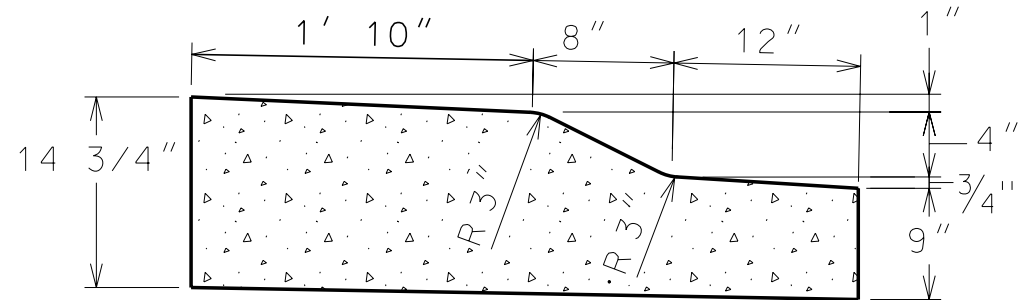

**TRAFFIC CIRCLE MOUNTABLE CONCRETE CURB & GUTTER**

**GENERAL NOTES:**

LATERAL CONTRACTION JOINTS SHALL BE PLACED AT INTERVALS OF NOT MORE THAN 15' NOR LESS THAN 6' IN LENGTH. THE JOINTS SHALL BE A MINIMUM OF 3" IN DEPTH

EXPANSION JOINTS SHALL BE PLACED TRANSVERSLY AT RADIUS POINTS ON CURVES OF RADIUS 200' OR LESS, AND AT ANGLE POINTS, OR AS DIRECTED BY THE ENGINEER. THE EXPANSION JOINT SHALL BE A ONE PIECE ASPHALTIC MATERIAL HAVING THE SAME DIMENSIONS AS CURB & GUTTER AT THAT STATION AND BE 1/2" THICK.

IN ALL CASES, CONCRETE CURB & GUTTER SHALL BE PLACED ON THOROUGHLY COMPACTED CRUSHED STONE

2009

CITY OF MADISON  
ENGINEERING DIVISION

**MADISON STANDARD  
CONCRETE CURB & GUTTER**

STANDARD DETAIL DRAWING 3.06

3.06



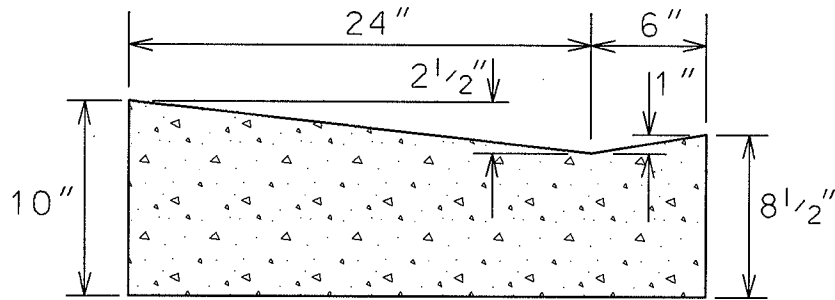

DRIVEWAY SECTION  
CONCRETE CURB & GUTTER  
TYPE 'X'  
(PAY AS TYPE 'X' CURB & GUTTER)

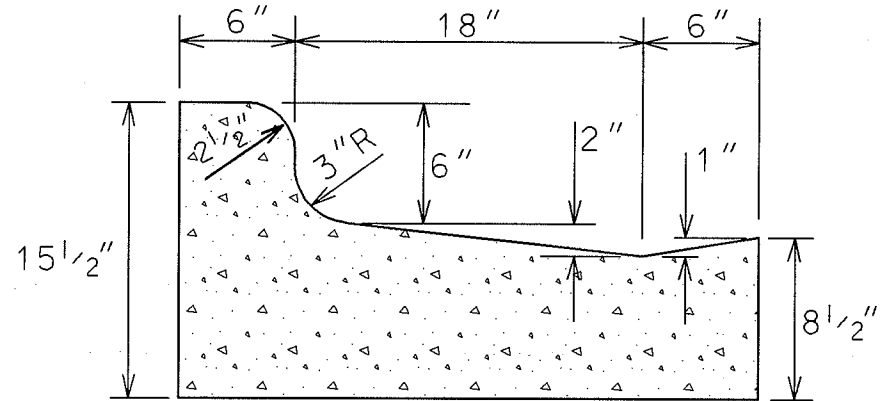

TYPE 'X' CONCRETE  
CURB & GUTTER

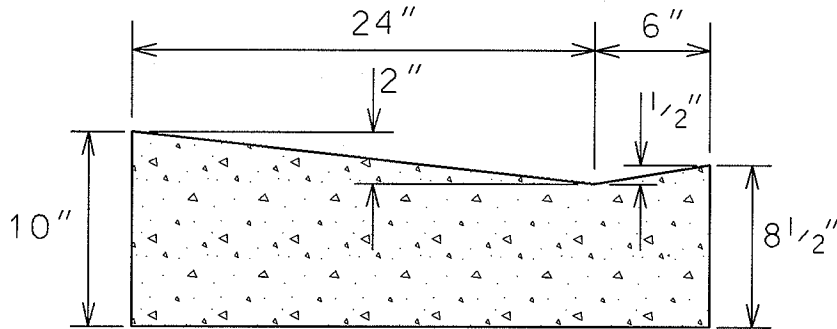

PEDESTRIAN RAMP SECTION  
CONCRETE CURB & GUTTER  
TYPE 'X'  
(PAY AS TYPE 'X' CURB & GUTTER)

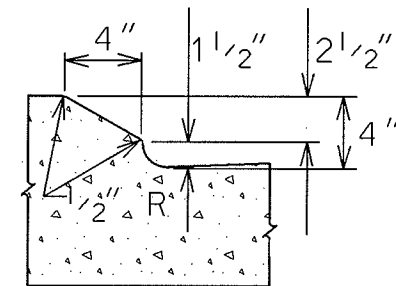

MOWER ACCESS  
CURB & GUTTER  
(PAY AS ADJACENT  
CURB & GUTTER TYPE)

GENERAL NOTES:

LATERAL CONTRACTION JOINTS SHALL BE PLACED AT INTERVALS OF NOT MORE THAN 15' NOR LESS THAN 6' IN LENGTH. THE JOINTS SHALL BE A MINIMUM OF 3" IN DEPTH

EXPANSION JOINTS SHALL BE PLACED TRANSVERSLY AT RADIUS POINTS ON CURVES OF RADIUS 200' OR LESS, AND AT ANGLE POINTS, OR AS DIRECTED BY THE ENGINEER. THE EXPANSION JOINT SHALL BE A ONE PIECE ASPHALTIC MATERIAL HAVING THE SAME DIMENSIONS AS CURB & GUTTER AT THAT STATION AND BE 1/2" THICK.

IN ALL CASES, CONCRETE CURB & GUTTER SHALL BE PLACED ON THOROUGHLY COMPACTED CRUSHED STONE

3.07

2004

CITY OF MADISON  
ENGINEERING DIVISION

MADISON STANDARD  
CONCRETE CURB & GUTTER

STANDARD DETAIL DRAWING 3.07

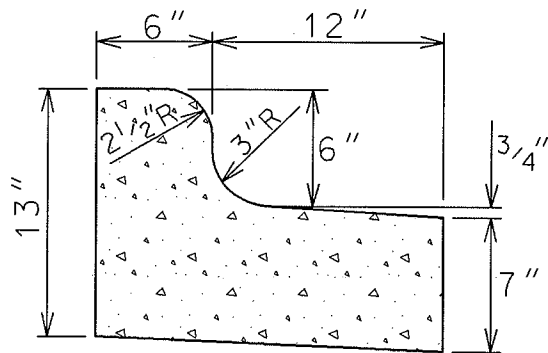

TYPE 'D' CONCRETE CURB & GUTTER

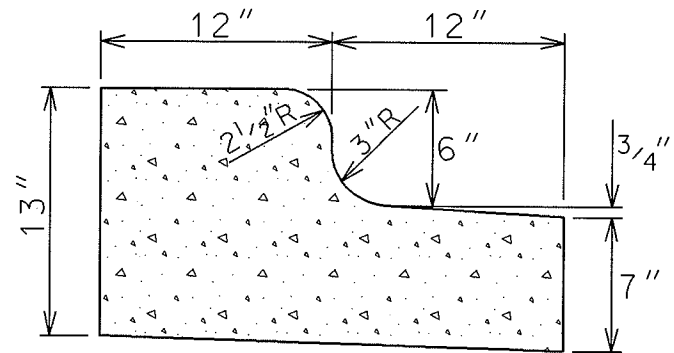

TYPE 'E' CONCRETE CURB & GUTTER

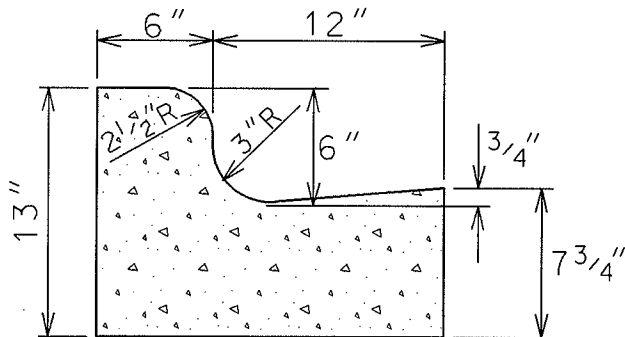

TYPE 'G' CONCRETE CURB & GUTTER

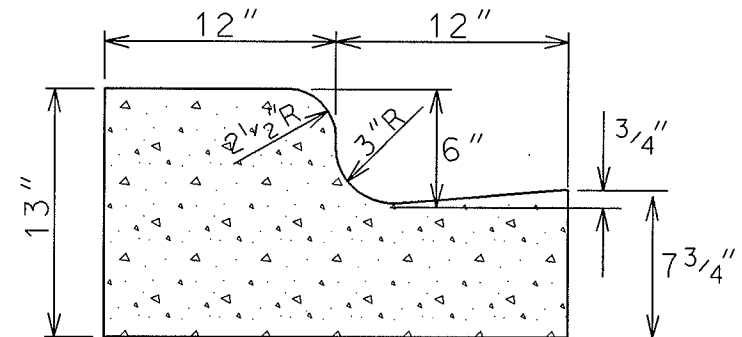

TYPE 'H' CONCRETE CURB & GUTTER

GENERAL NOTES:

LATERAL CONTRACTION JOINTS SHALL BE PLACED AT INTERVALS OF NOT MORE THAN 15' NOR LESS THAN 6' IN LENGTH. THE JOINTS SHALL BE A MINIMUM OF 3" IN DEPTH

EXPANSION JOINTS SHALL BE PLACED TRANSVERSLY AT RADIUS POINTS ON CURVES OF RADIUS 200' OR LESS, AND AT ANGLE POINTS, OR AS DIRECTED BY THE ENGINEER. THE EXPANSION JOINT SHALL BE A ONE PIECE ASPHALTIC MATERIAL HAVING THE SAME DIMENSIONS AS CURB & GUTTER AT THAT STATION AND BE 1/2" THICK.

IN ALL CASES, CONCRETE CURB & GUTTER SHALL BE PLACED ON THOROUGHLY COMPACTED CRUSHED STONE

80.5

2004

CITY OF MADISON  
ENGINEERING DIVISION

MADISON STANDARD  
CONCRETE CURB & GUTTER

STANDARD DETAIL DRAWING 3.08

COMMERCIAL DRIVEWAY DETAIL

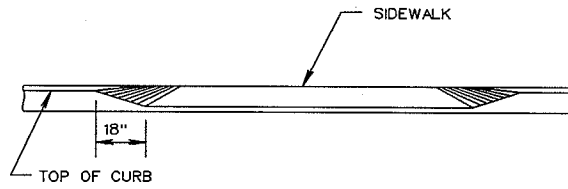

SECTION A-A

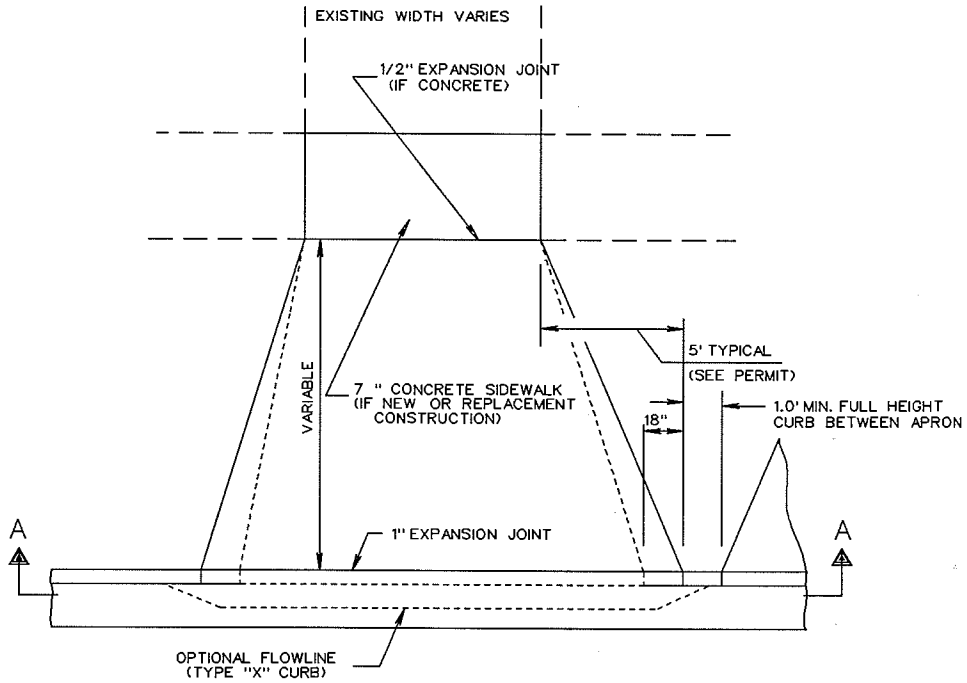

PLAN

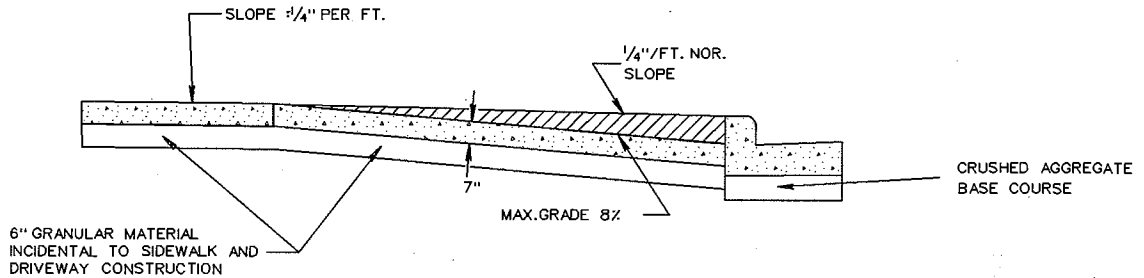

PROFILE

2004

CITY OF MADISON ENGINEERING DIVISION
<b>MADISON STANDARD COMMERCIAL DRIVE DETAILS</b>
STANDARD DETAIL DRAWING 3.09

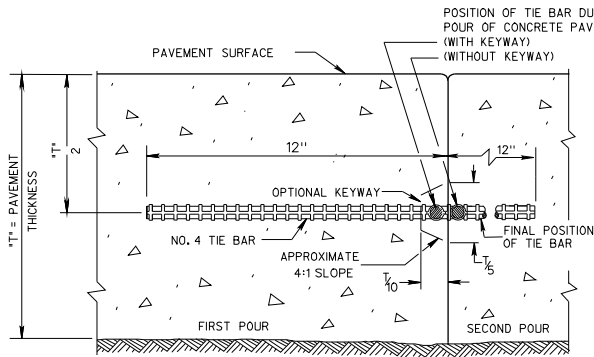

CONSTRUCTION JOINT

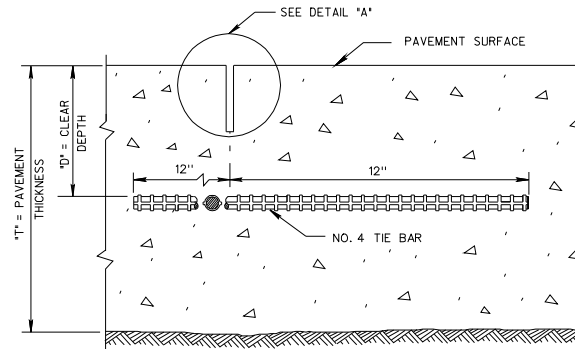

SAWED JOINT

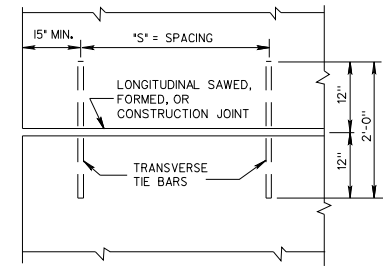

PLAN VIEW  
SHOWING LOCATION OF TIE BARS

(A) NEW CONCRETE INCLUDES NEW CURB & GUTTER, SURFACE DRAINS, CONCRETE PAVEMENT OR OTHER CONCRETE

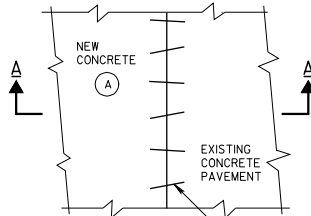

PLAN VIEW

NO. 6 TIE BARS SPACED 3'-0" C-C, INSTALLED ON 6:1 SKEW HORIZONTALLY. DIRECTION OF SKEW ALTERNATING AFTER EVERY ONE OR TWO BARS. (1)

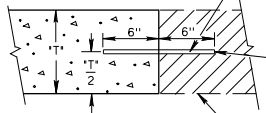

SECTION A-A  
PAVEMENT TIES

THE HOLE FOR THE BAR SHALL BE DRILLED TO A DEPTH OF 7" AND TO SUCH A DIAMETER AS TO PROVIDE A TIGHT DRIVEN FIT.

EXIST. CONC. PAVEMENT

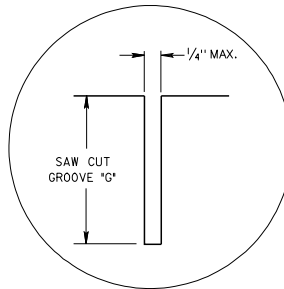

DETAIL "A"

GENERAL NOTES

DETAILS OF CONSTRUCTION NOT SHOWN ON THIS DRAWING SHALL CONFORM TO THE PERTINENT REQUIREMENTS OF THE STANDARD SPECIFICATIONS AND THE APPLICABLE SPECIAL PROVISIONS.

TIE BARS & DOWEL BARS FOR ALL NEW CONSTRUCTION SHALL BE INCIDENTAL TO THE CONCRETE ITEM, INCLUDING DRILLING INTO EXISTING CONCRETE PAVEMENT OR CURB & GUTTER. LONGITUDINAL JOINTS SHALL NOT BE SEALED OR FILLED.

TIE BAR SPACINGS ARE VALID ONLY FOR PAVEMENT WIDTHS IN THE TABLE. FOR WIDER PAVEMENTS, TIED CONCRETE SHOULDERS OR RAMPS, THE TIE BAR SPACING SHALL BE AS SHOWN ON THE PLANS.

(1) ANCHOR TIE BARS INTO DRILLED HOLES WITH AN EPOXY.

PAVEMENT THICKNESS "T"	CLEAR DEPTH "D"	SAW CUT GROOVE "G"	MAXIMUM TIE BAR SPACING "S"	
			PAVEMENT WIDTH 24' OR 26'	30'
6, 6 1/2"	3" 1/2"	2"	48"	42"
7, 7 1/2"	3 1/4" 1"	2 1/4"	45"	36"
8, 8 1/2"	3 3/4" 1"	2 1/2"	39"	30"
9, 9 1/2"	4 1/4" 1"	3"	33"	27"
10, 10 1/2"	4 3/4" 1"	3 1/4"	30"	24"
11, 11 1/2"	5 1/4" 1"	3 3/4"	27"	21"
12"	5 3/4" 1"	4"	24"	21"

2012

CITY OF MADISON  
ENGINEERING DIVISION

LONGITUDINAL JOINTS  
AND PAVEMENT TIES  
DETAIL

STANDARD DETAIL DRAWING 3.10

GENERAL NOTES

DETAILS OF CONSTRUCTION NOT SHOWN ON THIS DRAWING SHALL CONFORM TO THE STANDARD SPECIFICATIONS AND SPECIAL PROVISIONS.  
 CONTRACTION JOINTS  
 UNLESS OTHERWISE SPECIFIED, CONTRACTION JOINTS SHALL BE NORMAL TO THE CENTERLINE. THE LOCATION OF CONTRACTION JOINTS THRU INTERSECTIONS SHALL BE AS SHOWN ON THE PLANS OR AS DIRECTED BY THE ENGINEER.

CONTRACTION JOINTS SHALL NOT BE SEALED OR FILLED.

DOWEL BARS SHALL BE INSTALLED PARALLEL TO THE PAVEMENT CENTERLINE AND PAVEMENT SURFACE.

FOR PAVEMENT SLABS OF VARYING WIDTHS, CENTER THE DOWEL ASSEMBLY ACROSS THE LANES. LOCATE THE INNER AND OUTER MOST DOWEL BARS SO THAT THE CENTER OF THE BARS ARE A MINIMUM OF 6 INCHES AND A MAXIMUM OF 12 INCHES FROM THE LONGITUDINAL JOINT AND THE EDGE OF PAVMENT.

CONSTRUCTION JOINTS  
 CONSTRUCTION JOINTS SHALL BE A MINIMUM OF 4 FEET FROM THE NEAREST CONTRACTION JOINT AND ALIGNED EITHER PARALLEL TO CONTRACTION JOINTS OR AT 90° TO THE CENTERLINE. TIE BARS MAY BE INSERTED THROUGH THE HEADER BOARD AFTER THE CONCRETE HAS BEEN PLACED.

① ALTERNATIVE DESIGNS OF THE DOWEL ASSEMBLY MAY BE USED WHEN APPROVED BY THE ENGINEER. MECHANICAL DOWEL BAR IMPLANTERS MAY BE USED INSTEAD OF DOWEL ASSEMBLIES.

② DOWEL BARS SHALL BE ANCHORED INTO DRILL HOLES WITH AN APPROVED EPOXY GROUT.

③ APPLY A THIN UNIFORM COATING OF SURFACE TREATMENT TO THE FREE END OF THE DOWEL BARS TO BREVENT BONDING.

④ DOWEL BARS INSTALLED BY DRILLING SHALL BE SPACED 1'-3" ON CENTER. THE GROUPING OF DOWEL BARS SHALL BE CENTERED INSIDE THE SLAB BASED ON ALL THE FOLLOWING SITUATIONS:

BETWEEN THE EDGES OF PAVEMENTS WITHOUT LONGITUDINAL JOINTS OR  
 BETWEEN THE EDGE OF PAVEMENT AND NEAREST LONGITUDINAL JOINT OR  
 BETWEEN TWO ADJACENT LONGITUDINAL JOINTS.

⑤ SECURE BASKETS WITH ANCHORS TO HOLD DOWEL BARS IN THE CORRECT POSITION AND ALIGNMENT, TYPE, LOCATION, NUMBER AND LENGTH OF ANCHORS ARE DEPENDENT UPON FIELD CONDITIONS.

NOTE: THE CLEAR DISTANCE FROM THE EDGE OF PAVEMENT OR LONGITUDINAL JOINT TO THE NEAR EDGE OF DOWEL BAR NEAREST THAT EDGE OR JOINT SHALL BE A MINIMUM OF 6 INCHES AND A MAXIMUM OF 14 INCHES. TIE BARS & DOWEL BARS FOR ALL NEW CONSTRUCTION SHALL BE INCIDENTAL TO THE CONCRETE ITEM, INCLUDING DRILLING INTO EXISTING CONCRETE PAVEMENT OR CURB & GUTTER.

18" DOWEL BARS  
 ANCHORED INTO EXISTING PAV'T.

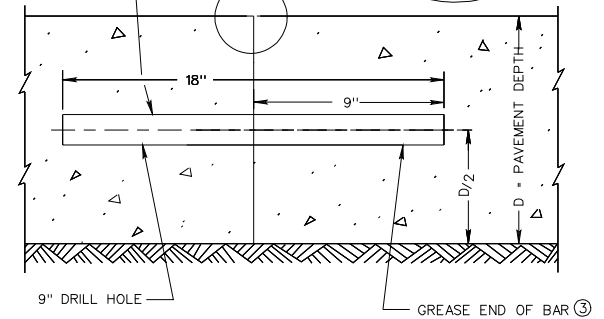

TRANSVERSE CONTRACTION JOINTS ABUTTING EXISTING PAVEMENT

④ DOWEL BAR DETAIL

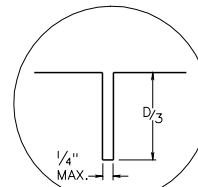

JOINT DETAIL

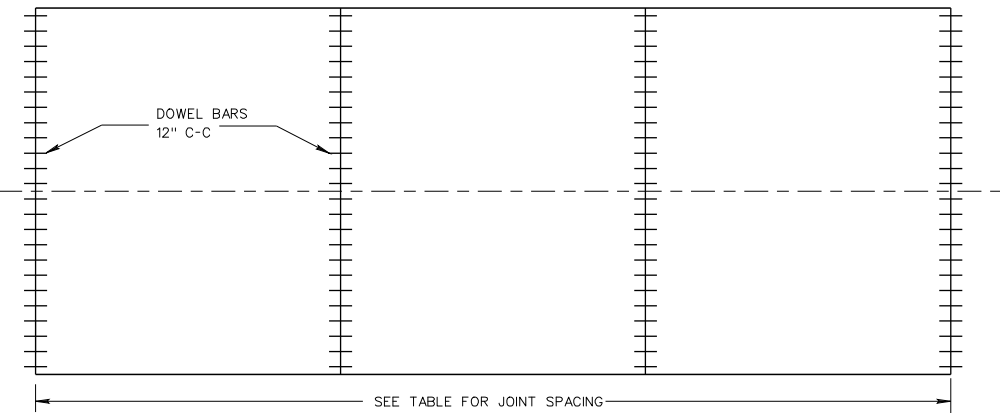

CONTRACTION JOINT LOCATIONS

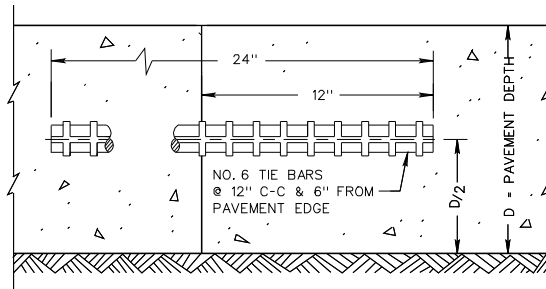

CONSTRUCTION JOINT

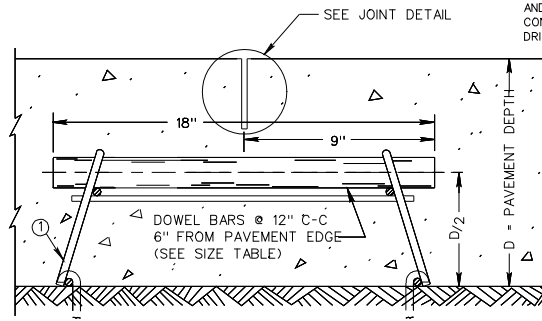

DOWELED CONTRACTION JOINT

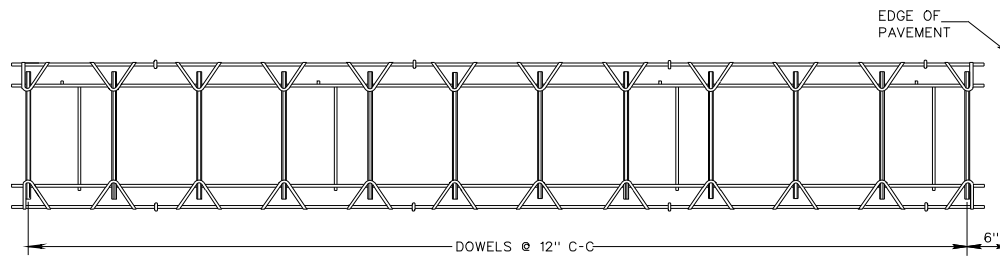

PLAN VIEW



SIDE VIEW  
 CONTRACTION JOINT DOWEL ASSEMBLY ①

PAVEMENT DEPTH, DOWEL BAR SIZE AND JOINT SPACING TABLE

PAVEMENT DEPTH (D)	DOWEL BAR DIAMETER	CONTRACTION JOINT SPACING
6", 6 1/2"	1 1/4"	12'
7", 7 1/2"	1 1/4"	14'
8", 8 1/2"	1 1/4"	15'
9", 9 1/2"	1 1/4"	15'
10" & ABOVE	1 1/2"	15'

CITY OF MADISON  
 ENGINEERING DIVISION

DOWELED CONCRETE PAVEMENT DETAIL

STANDARD DETAIL DRAWING 3.11

2012

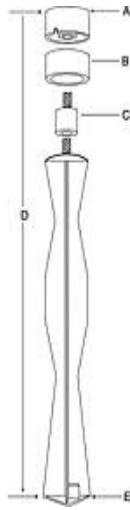

A = 4" (102 mm)

B = 2" (51 mm) PVC support ring extension

C = 2" PVC threaded inner support extension

D = 31.5" (800 mm) overall length assembled

E = 3.5" (89 mm)

30" Extendable Break-off Monument (Plastic Base, Bronze Survey Cap)

**R-1968**

**Adjustable Monument Box,  
Type 36-B**

Heavy Duty

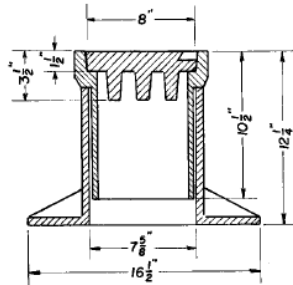

Note: Casting and monument as shown or approved equal shall be supplied by City of Madison.

CITY OF MADISON ENGINEERING DIVISION
<b>MADISON STANDARD SECTION CORNER MONUMENT</b>
STANDARD DETAIL DRAWING 3.12

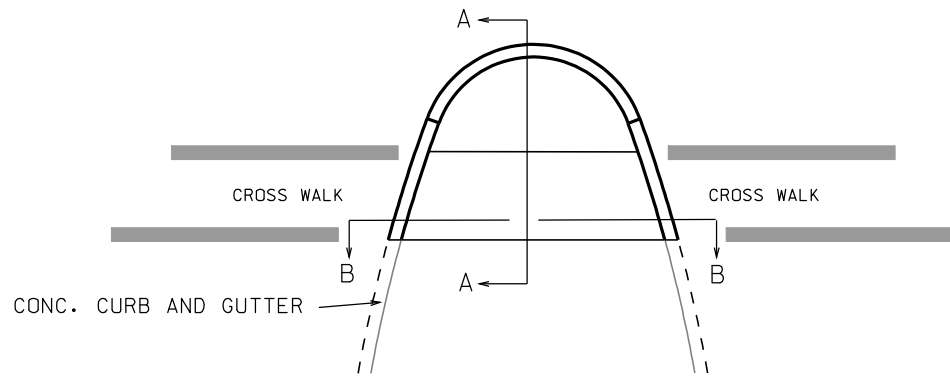

DETAIL  
CONCRETE MOUNTABLE MEDIAN ISLAND NOSE

CROSS WALK 2' OR FARTHER FROM  
END OF ISLAND NOSE

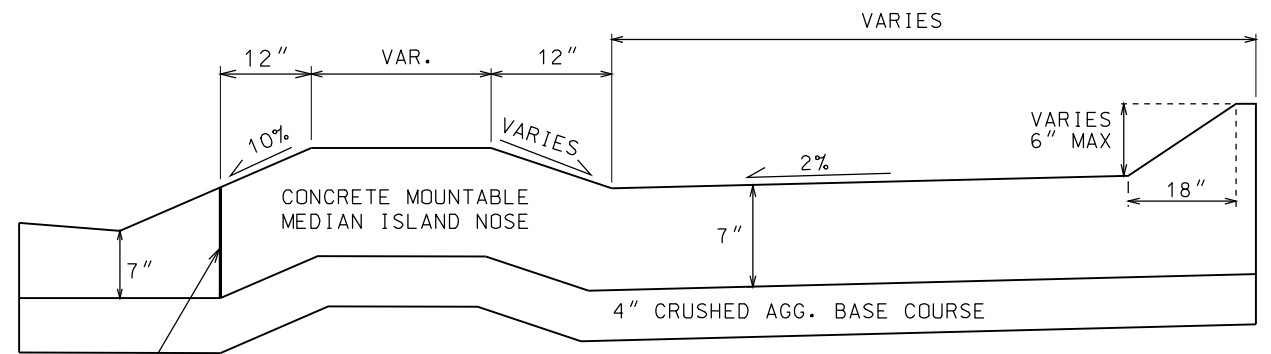

1/2" EXPANSION JOINT AND  
TIE BARS REQUIRED IF  
POURED SEPARATELY (TYP.)

SECTION A-A

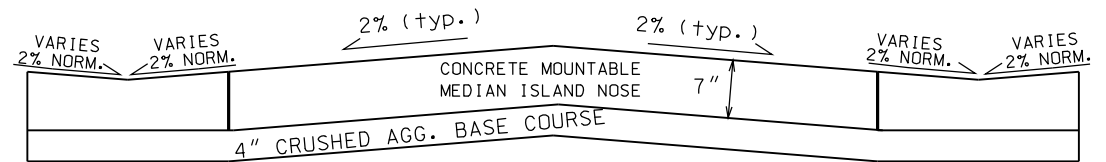

SECTION B-B / BB-BB

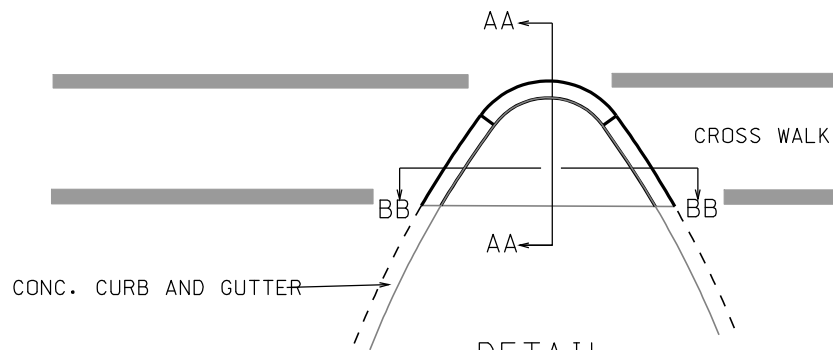

DETAIL  
CONCRETE MOUNTABLE MEDIAN ISLAND NOSE

CROSS WALK THRU  
ISLAND NOSE

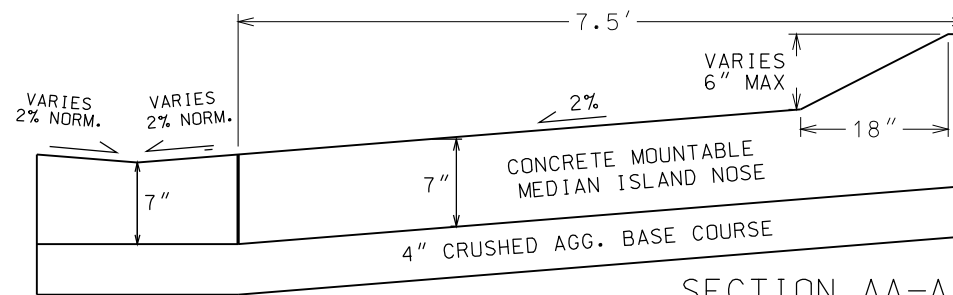

SECTION AA-AA

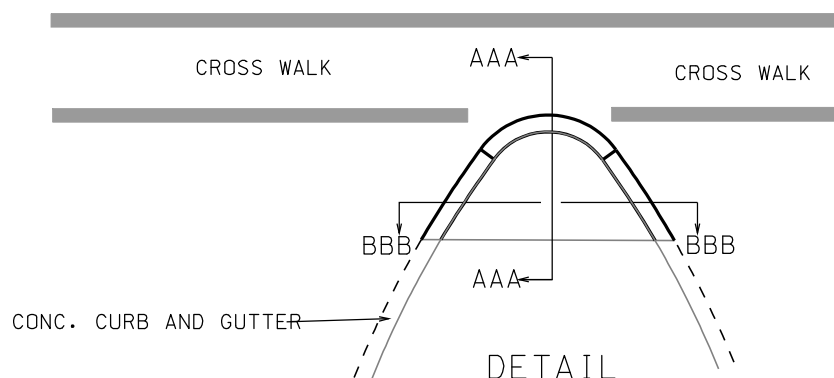

DETAIL  
CONCRETE MOUNTABLE MEDIAN ISLAND NOSE

CROSS WALK AT END / APPROACH  
ISLAND NOSE

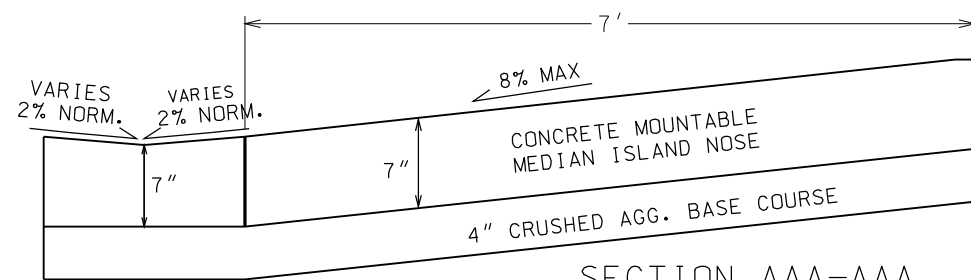

SECTION AAA-AAA

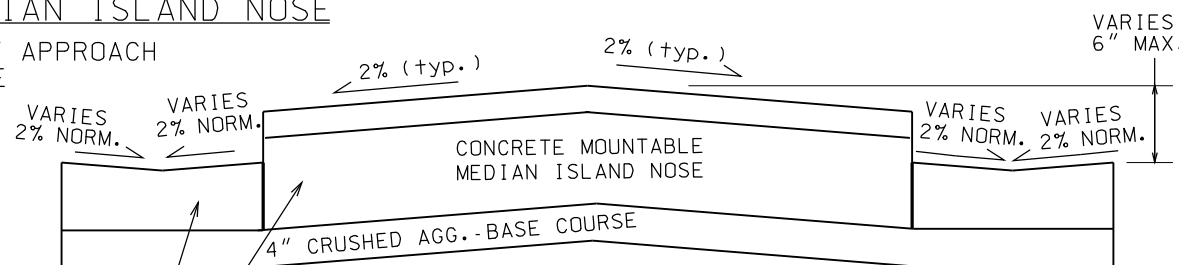

SECTION BBB-BBB

PAID AS CONCRETE MOUNTABLE  
MEDIAN ISLAND NOSE (TYP.)

2011

CITY OF MADISON  
ENGINEERING DIVISION

CONCRETE MOUNTABLE  
MEDIAN ISLAND  
NOSE DETAILS

STANDARD DETAIL DRAWING 3.13

3.13

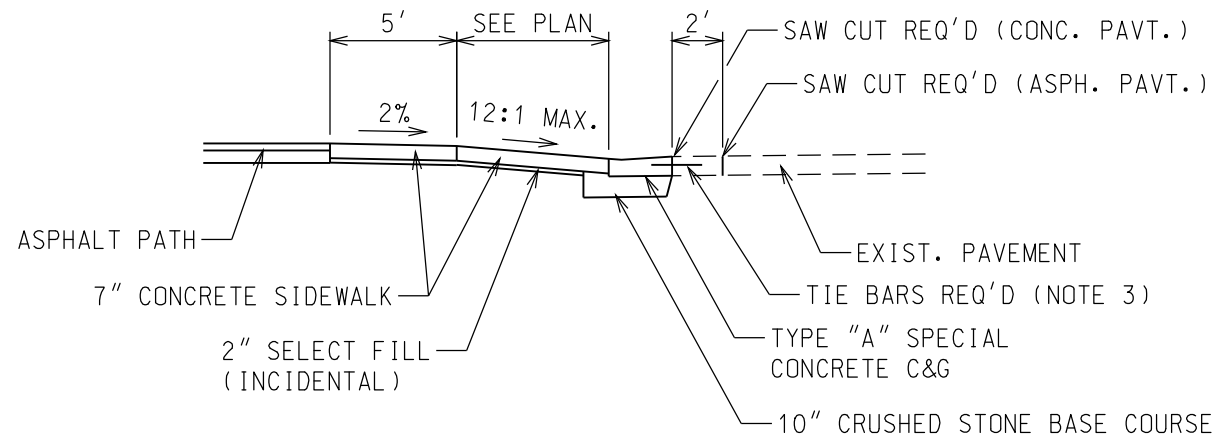

BIKE PATH RAMP SECTION A-A

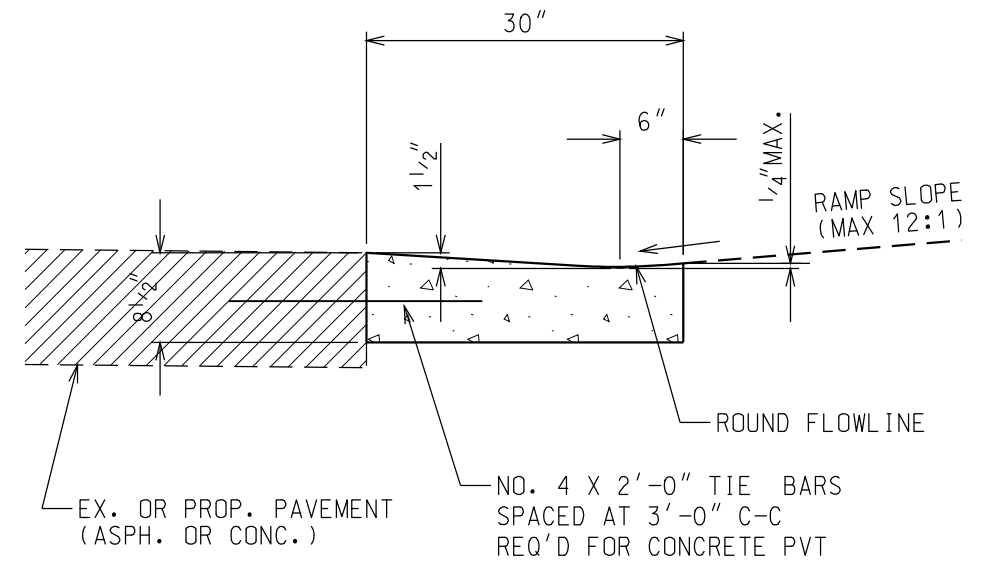

TYPE "A" SPECIAL CURB & GUTTER

NOTES:

1. CURB RAMP DETECTABLE WARNING FIELDS REQUIRED WHERE PATH RAMP ENTERS A STREET.
2. FOR ANGLES LESS THAN 75° OR GREATER THAN 105° FLARE DIMENSIONS SHALL BE AS SHOWN ON THE PLANS OR SHALL BE REVIEWED BY THE CONSTRUCTION ENGINEER PRIOR TO CONSTRUCTION.
3. THE DETECTABLE WARNING SURFACE SHALL BE LOCATED SO THAT THE EDGE NEAREST THE CURB LINE IS 6 INCHES MINIMUM AND 8 INCHES MAXIMUM FROM THE CURB LINE

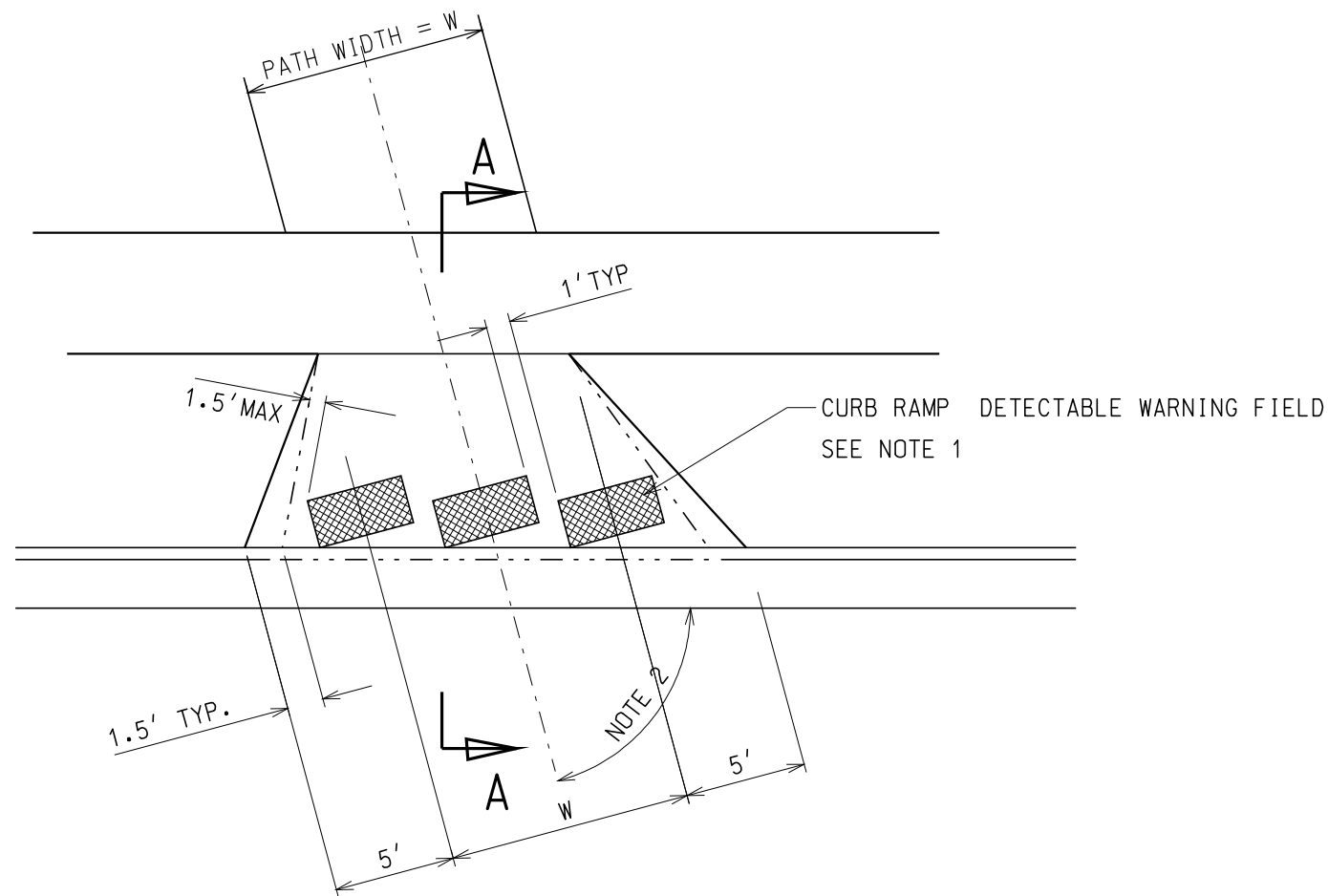

BIKE PATH RAMP PLAN

2010

CITY OF MADISON  
ENGINEERING DIVISION

BIKE RAMP CURB  
RAMP DETAIL

STANDARD DETAIL DRAWING 3.14



4.01

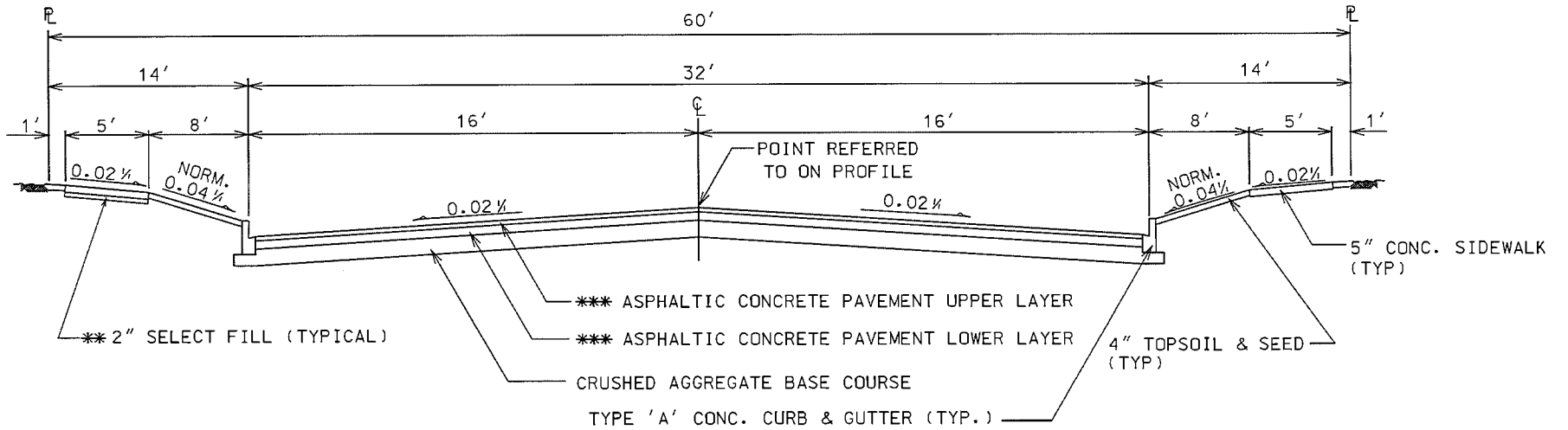

NOTES:

- \* A PAVEMENT DESIGN IN ACCORDANCE WITH STANDARD DETAIL DRAWING 4.06 IS REQUIRED ON ALL PROJECTS.
- \*\* 3" OF CRUSHED AGGREGATE BASE COURSE GRADATION 3 SHALL BE PLACED UNDER THE SIDEWALK WHERE THE CENTERLINE GRADE OF THE STREET EXCEEDS 5%.
- \*\*\* ALL UPPER LAYER PAVEMENTS ARE 12.5 mm; LOWER LAYER PAVEMENT IS 12.5 mm FOR TYPE A & 19 mm FOR TYPE B & C.

NOTES:

- \* A PAVEMENT DESIGN IN ACCORDANCE WITH STANDARD DETAIL DRAWING 4.06 IS REQUIRED ON ALL PROJECTS
- \*\* 3" OF CRUSHED AGGREGATE BASE COURSE GRADATION 3 SHALL BE PLACED UNDER THE SIDEWALK WHERE THE CENTERLINE GRADE OF THE STREET EXCEEDS 5%

\*CITY OF MADISON MINIMUM PAVEMENT DESIGN

TYPE	CRUSHED AGGREGATE BASE COURSE		ASPHALTIC CONCRETE PAVEMENT			
	LOWER LAYER GRADATION 1	UPPER LAYER GRADATION 2	LOWER LAYER		UPPER LAYER	
			TYPE	THICKNESS	TYPE	THICKNESS
A	6"	4"	E-0.3	1.75"	E-0.3	1.75"
B	6"	4"	E-1	2.25"	E-1	2.00"
C	6"	4"	E-3	3.25"	E-3	2.00"

2011

CITY OF MADISON ENGINEERING DIVISION
TYPICAL SECTION 32' STREET
STANDARD DETAIL DRAWING 4.01

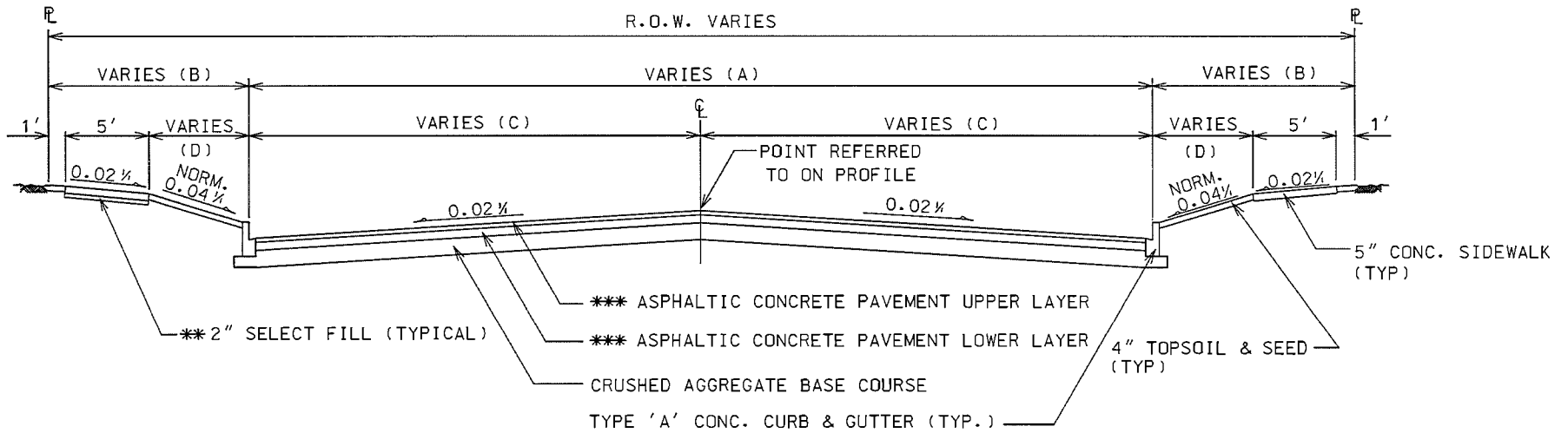

NOTES:

- \* A PAVEMENT DESIGN IN ACCORDANCE WITH STANDARD DETAIL DRAWING 4.06 IS REQUIRED ON ALL PROJECTS.
- \*\* 3" OF CRUSHED AGGREGATE BASE COURSE GRADATION 3 SHALL BE PLACED UNDER THE SIDEWALK WHERE THE CENTERLINE GRADE OF THE STREET EXCEEDS 5%.
- \*\*\* ALL UPPER LAYER PAVEMENTS ARE 12.5 mm; LOWER LAYER PAVEMENT IS 12.5 mm FOR TYPE A & 19 mm FOR TYPE B & C.

TYPICAL DIMENSIONS				
R.O.W.	A	B	C	D
60	32	14	16	8
66	36	15	18	9
66	40	13	20	7
80	44	18	22	12
80	54	13	27	7

\* CITY OF MADISON MINIMUM PAVEMENT DESIGN

TYPE	CRUSHED AGGREGATE BASE COURSE		ASPHALTIC CONCRETE PAVEMENT			
	LOWER LAYER GRADATION 1	UPPER LAYER GRADATION 2	LOWER LAYER		UPPER LAYER	
			TYPE	THICKNESS	TYPE	THICKNESS
A	6"	4"	E-0.3	1.75"	E-0.3	1.75"
B	6"	4"	E-1	2.25"	E-1	2.00"
C	6"	4"	E-3	3.25"	E-3	2.00"

2011

CITY OF MADISON  
ENGINEERING DIVISION

TYPICAL SECTION  
VARIOUS WIDTH STREETS

STANDARD DETAIL DRAWING 4.02

4.02

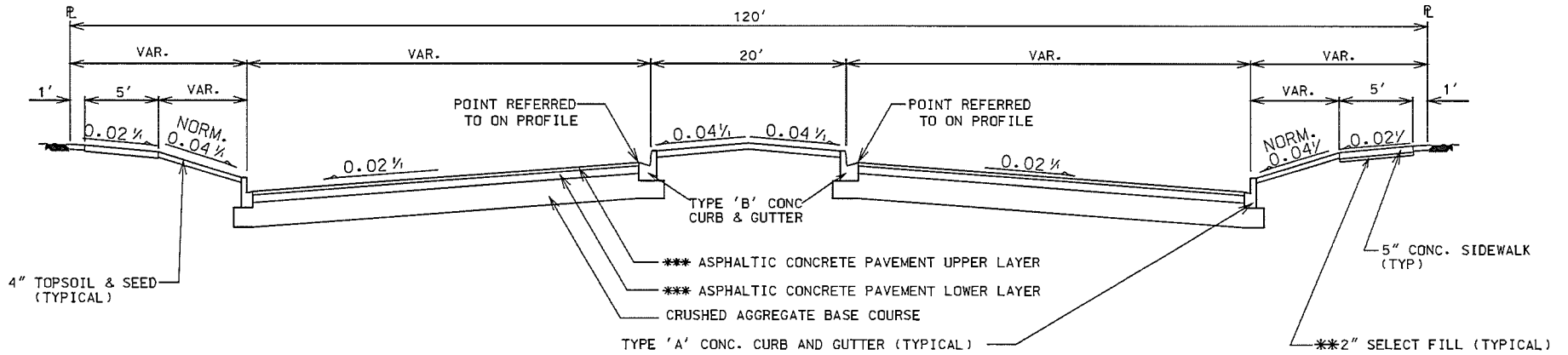

NOTES:

- \* A PAVEMENT DESIGN IN ACCORDANCE WITH STANDARD DETAIL DRAWING 4.06 IS REQUIRED ON ALL PROJECTS.
- \*\* 3" OF CRUSHED AGGREGATE BASE COURSE GRADATION 3 SHALL BE PLACED UNDER THE SIDEWALK WHERE THE CENTERLINE GRADE OF THE STREET EXCEEDS 5%.
- \*\*\* ALL UPPER LAYER PAVEMENTS ARE 12.5 mm; LOWER LAYER PAVEMENT IS 12.5 mm FOR TYPE A & 19 mm FOR TYPE B & C.

NOTES:

- \* A PAVEMENT DESIGN IN ACCORDANCE WITH STANDARD DETAIL DRAWING 4.06 IS REQUIRED ON ALL PROJECTS
- \*\* 3" OF CRUSHED AGGREGATE BASE COURSE GRADATION 3 SHALL BE PLACED UNDER THE SIDEWALK WHERE THE CENTERLINE GRADE OF THE STREET EXCEEDS 5%

\*CITY OF MADISON MINIMUM PAVEMENT DESIGN

TYPE	CRUSHED AGGREGATE BASE COURSE		ASPHALTIC CONCRETE PAVEMENT			
	LOWER LAYER GRADATION 1	UPPER LAYER GRADATION 2	LOWER LAYER		UPPER LAYER	
			TYPE	THICKNESS	TYPE	THICKNESS
A	6"	4"	E-0.3	1.75"	E-0.3	1.75"
B	6"	4"	E-1	2.25"	E-1	2.00"
C	6"	4"	E-3	3.25"	E-3	2.00"

2011

CITY OF MADISON ENGINEERING DIVISION
TYPICAL SECTION BOULEVARD STREET
STANDARD DETAIL DRAWING 4.03

4.04

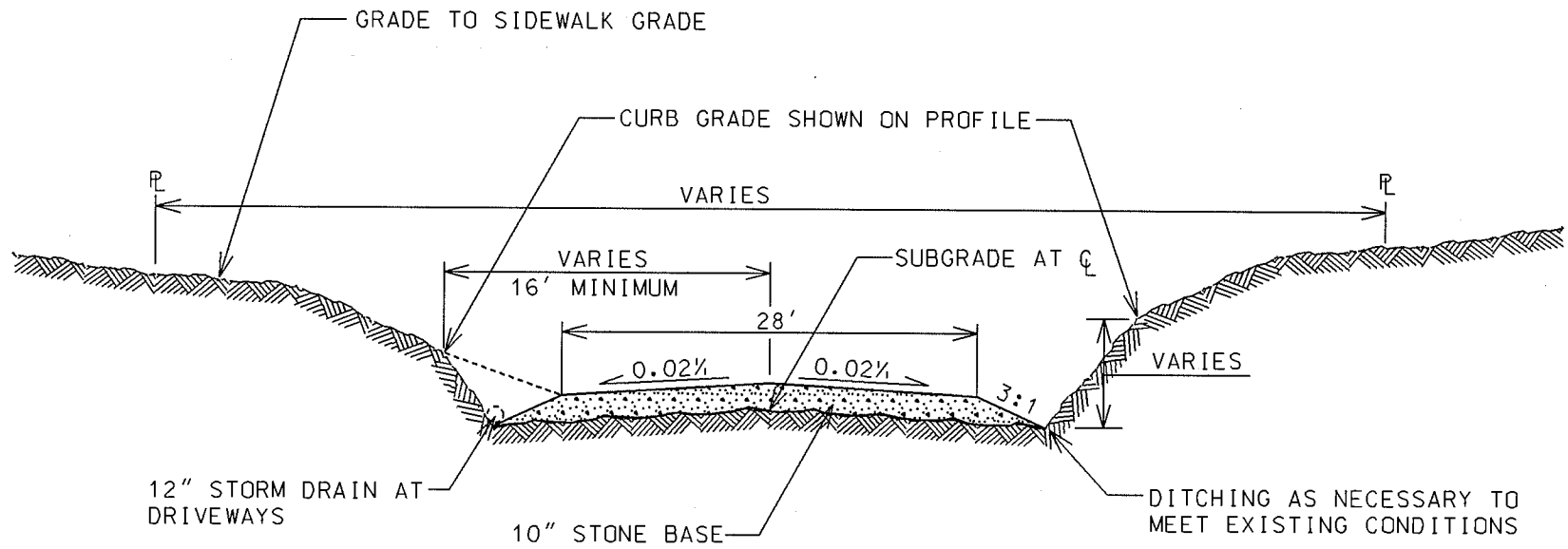

GENERAL NOTES:

SUBGRADE SHALL BE CONSTRUCTED IN ACCORDANCE WITH CITY OF MADISON STANDARD SPECIFICATIONS.

TERRACES AND SIDESLOPES SHALL BE TOPSOILED, SEEDED, FERTILIZED AND MULCHED IN ACCORDANCE WITH THE SPECIFICATIONS

2004

CITY OF MADISON  
ENGINEERING DIVISION

TYPICAL SECTION  
TEMPORARY STREET

STANDARD DETAIL DRAWING 4.04

4.05

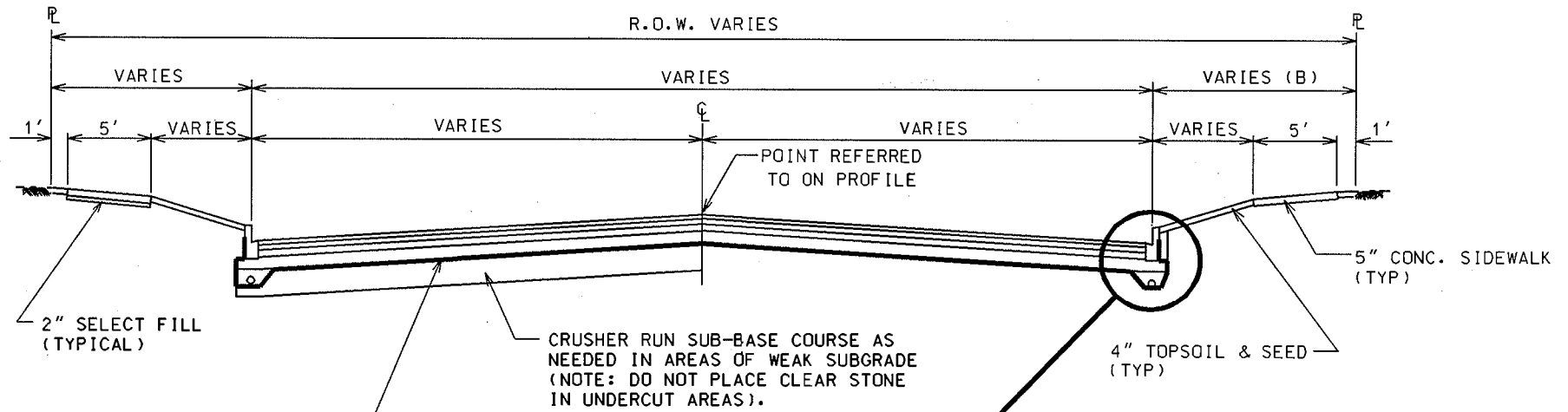

GEOTEXTILE FABRIC, WI-DOT TYPE SAS (NON-WOVEN) ENTIRE STREET IN AREAS OF UNDERDRAIN

TYPE 'A' CONC. CURB & GUTTER (TYPICAL)

FILL (INCIDENTAL)

ASPHALTIC CONC PAVEMENT UPPER LAYER  
 ASPHALTIC CONC PAVEMENT LOWER LAYER  
 CRUSHED AGG. BASE COURSE (GRADATION #2)  
 CLEAR STONE BASE COURSE (GRADATION #1)

GEOTEXTILE FABRIC WI DOT TYPE SAS (NON-WOVEN). FABRIC ACROSS FULL WIDTH OF ROAD AND WRAPPED UP BACK OF CURB

OPEN GRADED BASE COURSE (TYP) WI DOT GRADATION NO.2 AS SPECIFIED IN SECTION 501.2.5.4.4 OF WI DOT STANDARD SPECIFICATIONS

6" PERFORATED PIPE UNDERDRAIN, WRAPPED (TYP) PER SECTION 612 OF WI DOT STANDARD SPECIFICATIONS CENTER PIPE UNDER CURB AND GUTTER

UNDERDRAIN INSTALLATION

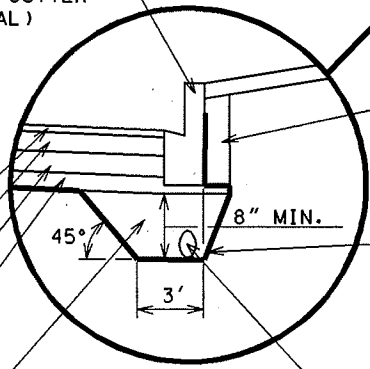

2004

CITY OF MADISON ENGINEERING DIVISION
<b>TYPICAL SECTION WITH UNDERDRAINS</b>
STANDARD DETAIL DRAWING 4.05

PAVEMENT DESIGN CRITERIA

Identification of roadway classification for pavement design.

Type A - Local street with low traffic volume.

Type B - Collector Type streets or any streets expected to become bus routes  
(Design Year  $DLT \leq 2500$ ).

Type C - Arterial Type streets - all streets expected to carry significant truck traffic  
(Design Year  $DLT > 2500$ ).

A.) Design procedure Type A roadway - use greater of:

1. The Standard Minimum Section:  
3.5" Asphaltic Pavement  
10" Crushed Aggregate Base Course
2. Pavement design based on Section 14-10-5 of the Wisconsin Department of Transportation's Facilities Development Manual. Use serviceability index (Pt) = 2.5, ESAL = 10 18K per day, and the soil support value given the existing field conditions. The Minimum Section is based on the above parameters and a soil support value of 3.5.

B.) Design Procedure Type B roadway - use greater of:

1. The Standard Minimum Section:  
4.25" Asphaltic Pavement  
10" Crushed Aggregate Base Course
2. Pavement design based on Section 14-10-5 of the Wisconsin Department of Transportation's Facilities Development Manual. Use serviceability index (Pt) = 2.5, ESAL = 20 18K per day, and the soil support value given the existing field conditions. The Minimum Section is based on the above parameters and a soil support value of 3.5.

C.) Design Procedure Type C roadway - use greater of:

1. The Standard Minimum Section:  
5.25" Asphaltic Pavement  
10" Crushed Aggregate Base Course
2. Pavement design based on Section 14-10-5 of the Wisconsin Department of Transportation's Facilities Development Manual. Use serviceability index (Pt) = 2.5, and the soil support value given the existing field conditions. The ESAL shall be calculated based on Section 14-1-5.

2007

CITY OF MADISON  
ENGINEERING DIVISION

PAVEMENT DESIGN  
CRITERIA

STANDARD DETAIL DRAWING 4.06

4.07

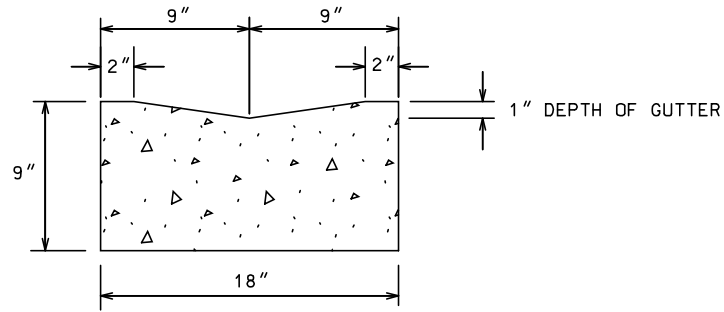

ALLEY GUTTER DETAIL

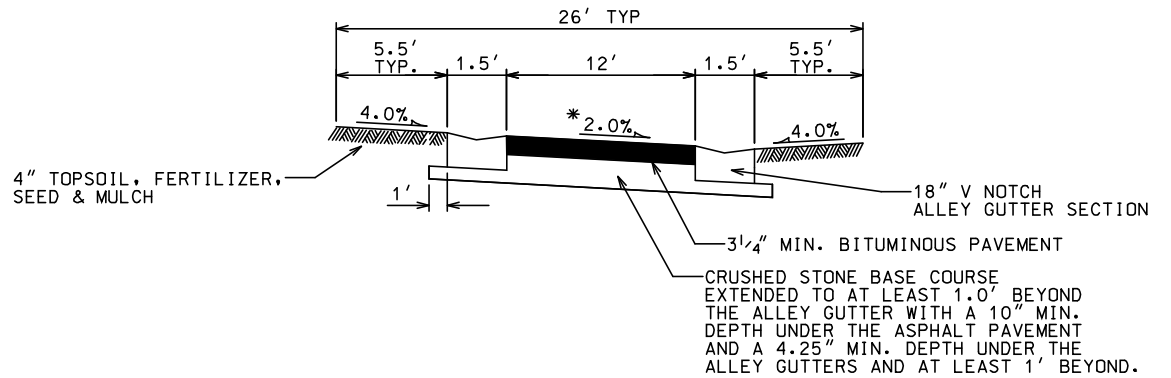

TYPICAL ALLEY SECTION

NOTES:

EDGE OF PAVEMENT RADII SHALL NOT BE LESS THAN 25 FEET

\* SEE ARROWS ON PLAN PAVEMENT FOR DIRECTION OF CROSS SLOPE.

CURBS SHALL HAVE A MINIMUM 0.5% LONGITUDINAL GRADE TOWARD INLETS.

ALL STORM WATER SHALL BE COLLECTED BY STORM SEWER INLETS PRIOR TO FLOWING OVER PRIVATE PROPERTY OR SIDEWALKS.

THE EDGE OF ALLEY PAVEMENT SHALL NOT BE CLOSER THAN 7.0' TO THE PROPERTY LINE AT ANY POINT.

2007

CITY OF MADISON  
ENGINEERING DIVISION

TYPICAL ALLEY WITH  
CURB & GUTTER

STANDARD DETAIL DRAWING 4.07

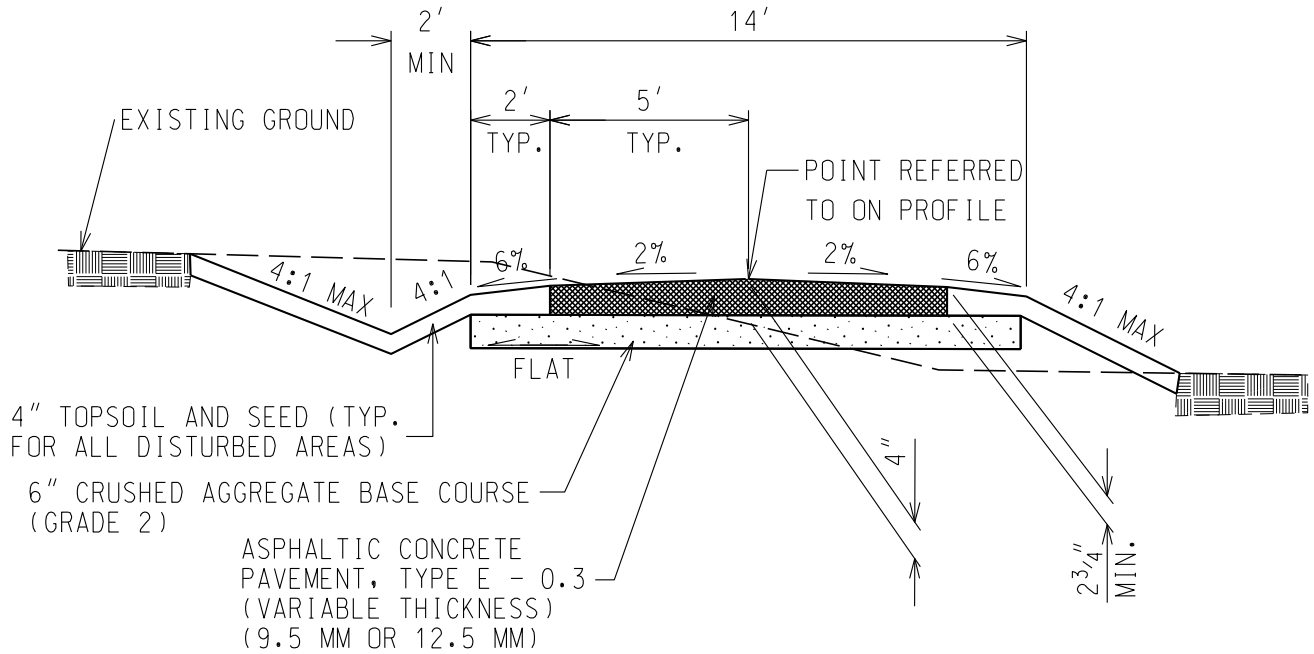

CROWNED PAVEMENT

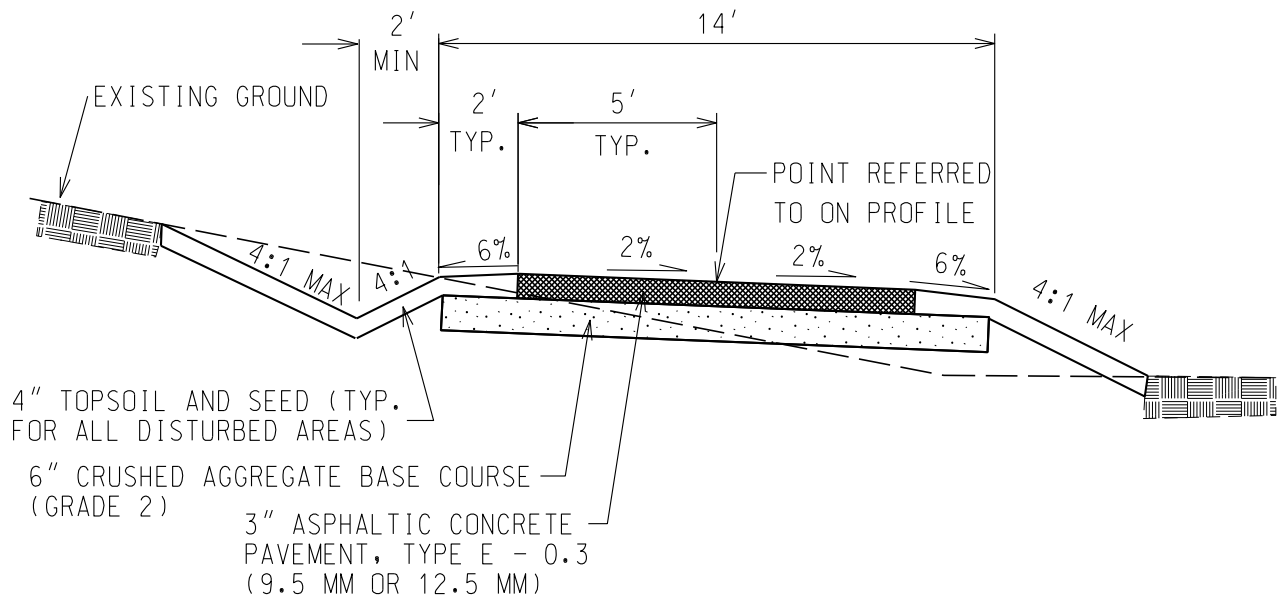

UNIFORM CROSS SLOPE

**GENERAL NOTES:**

1. GRADING SHALL INCLUDE REMOVING VEGETATION AND TOPSOIL, SHAPING AND COMPACTING THE SUBBASE.
2. SUITABLE FILL AS REQUIRED TO OBTAIN A SUITABLE CROSS SECTION SHALL BE PLACED AND COMPACTED IN 6 INCH MAXIMUM LIFTS.
3. ALL DISTURBED AREAS SHALL BE TOPSOILED AND SEEDED.

2014

CITY OF MADISON ENGINEERING DIVISION
<b>TYPICAL SECTION BIKE PATH</b>
STANDARD DETAIL DRAWING 4.08



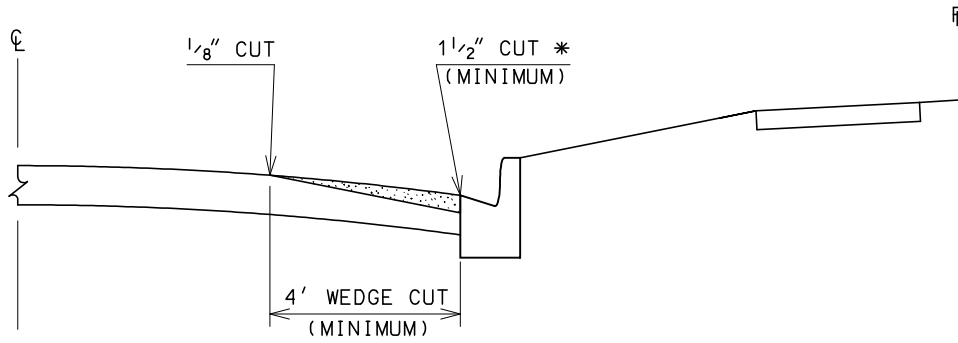

DETAIL "A"  
WEDGE CUT

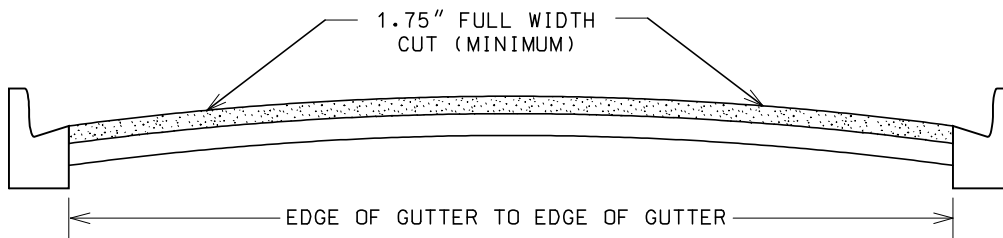

DETAIL "B"  
FULL WIDTH CUT

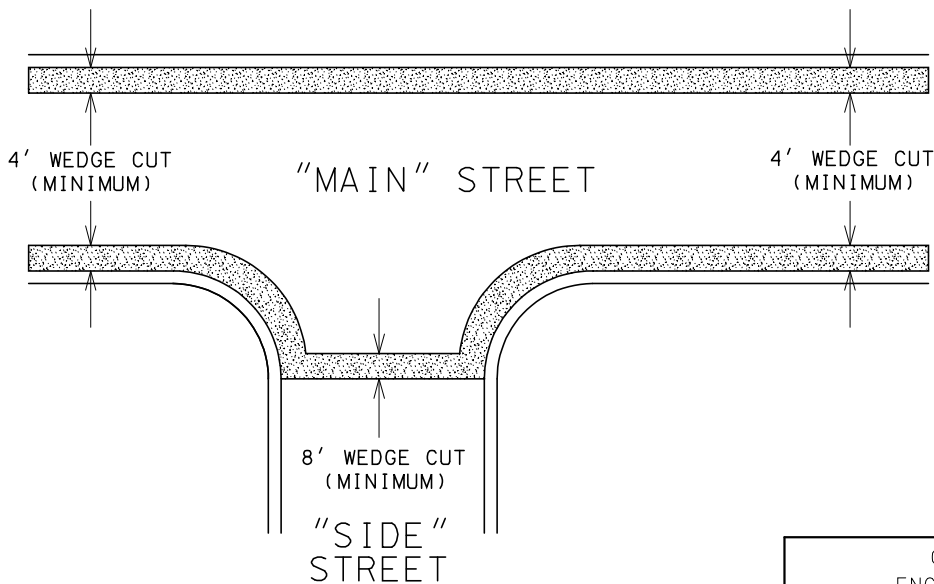

DETAIL "C"  
RADIUS RETURN CUTS

\* THE WEDGE CUT DEPTH SHALL MATCH THE DEPTH OF THE BITUMINOUS OVERLAY

2007

CITY OF MADISON  
ENGINEERING DIVISION

GRINDING DETAIL

STANDARD DETAIL DRAWING 4.09

# SPEED HUMP DETAIL

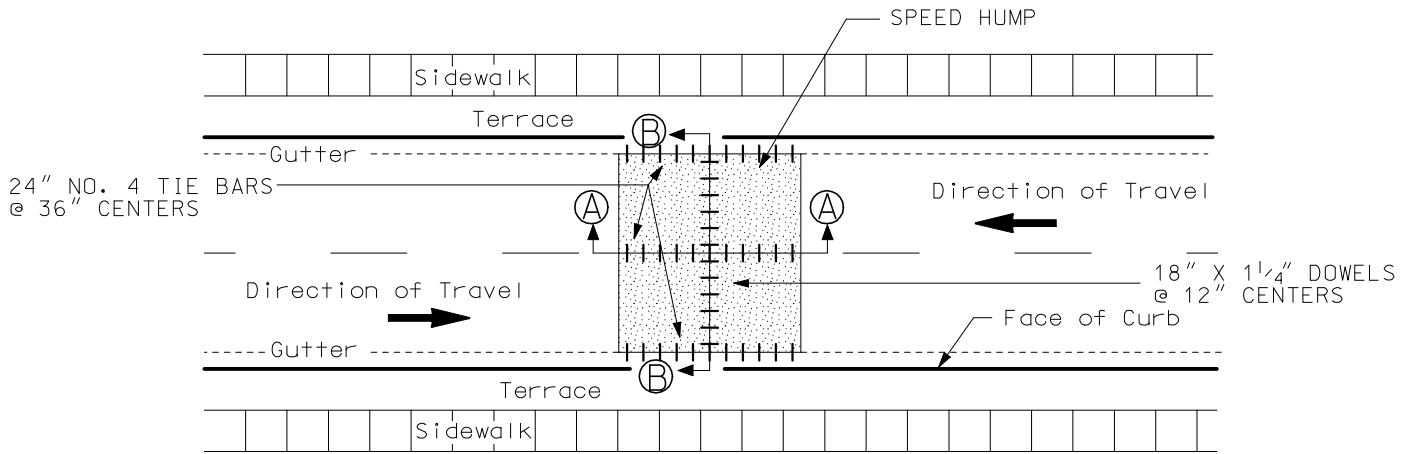

## PLAN VIEW

SPEED HUMP ON TYPICAL URBAN STREET

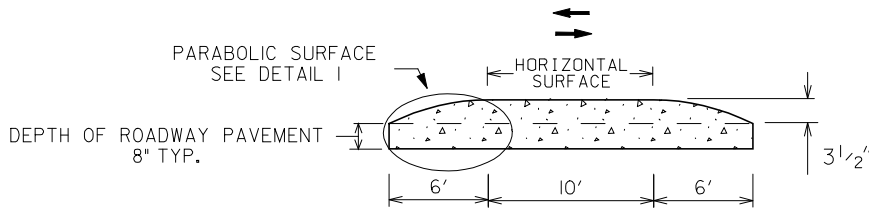

## SECTION AA

NOT TO SCALE  
(VERTICAL SCALE IS EXAGGERATED)

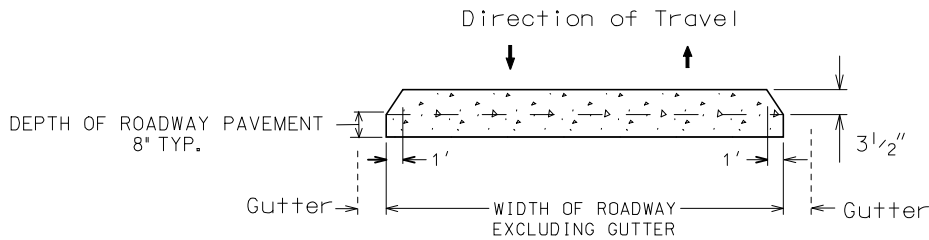

## SECTION BB

NOT TO SCALE  
(VERTICAL SCALE IS EXAGGERATED)

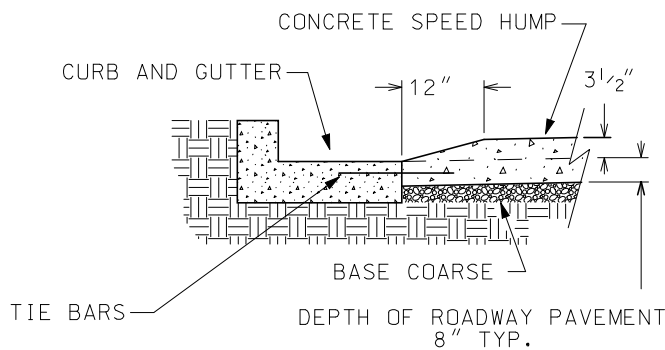

## CURB DETAIL

CROSS SECTION

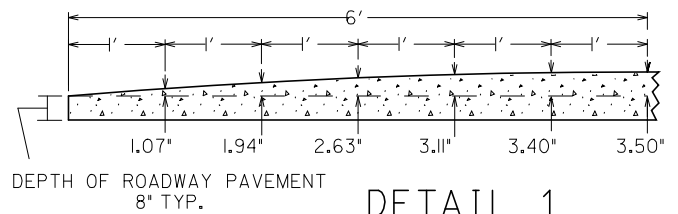

## DETAIL 1

PARABOLIC SURFACE

2008

CITY OF MADISON  
ENGINEERING DIVISION

CONCRETE SPEED HUMP  
FLOW THROUGH GUTTER

STANDARD DETAIL DRAWING 4.10

# SPEED HUMP DETAIL

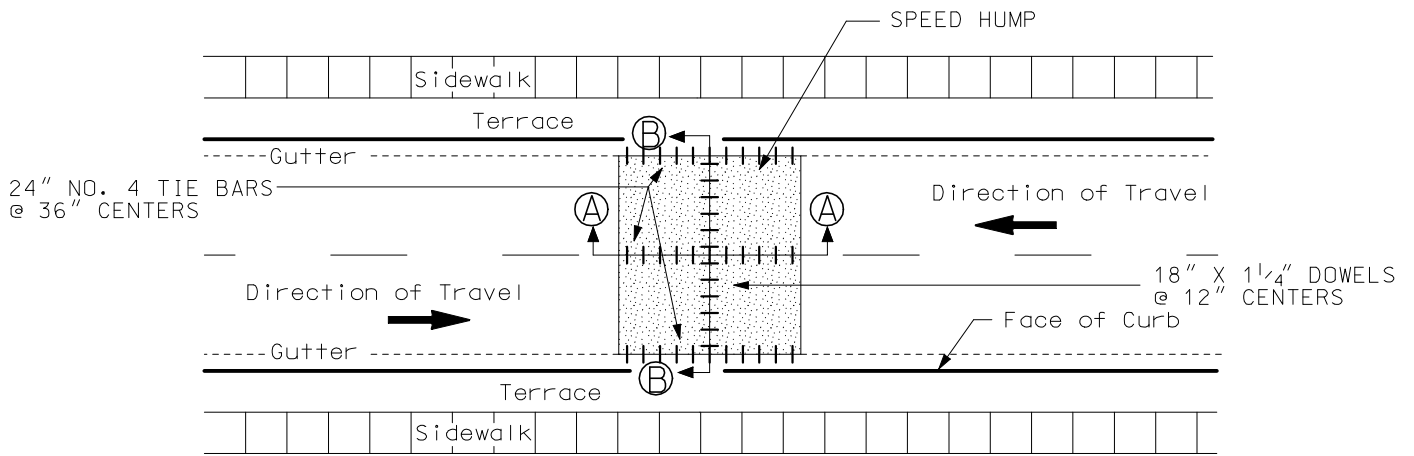

## PLAN VIEW

SPEED HUMP ON TYPICAL URBAN STREET

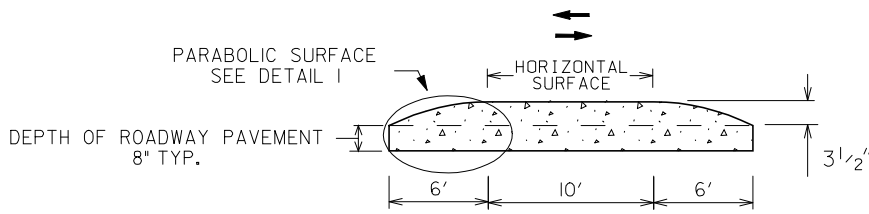

## SECTION AA

NOT TO SCALE  
(VERTICAL SCALE IS EXAGGERATED)

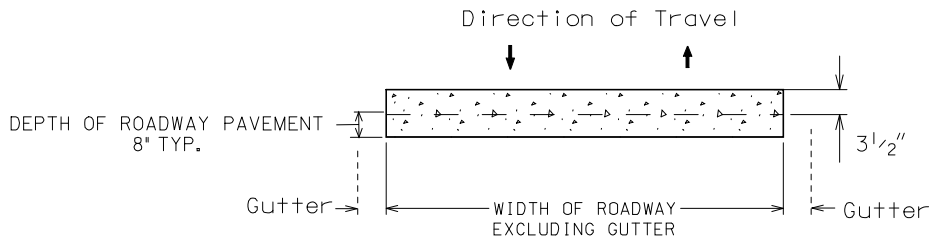

## SECTION BB

NOT TO SCALE  
(VERTICAL SCALE IS EXAGGERATED)

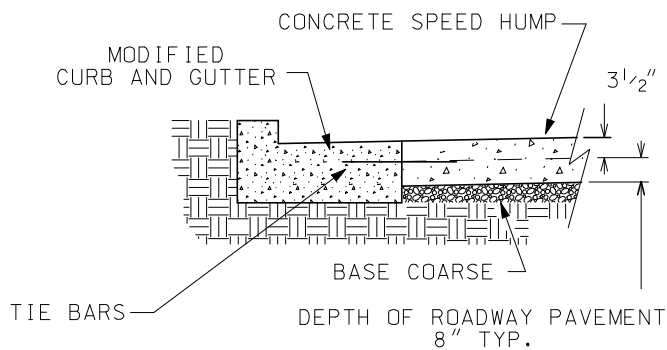

## CURB DETAIL

CROSS SECTION

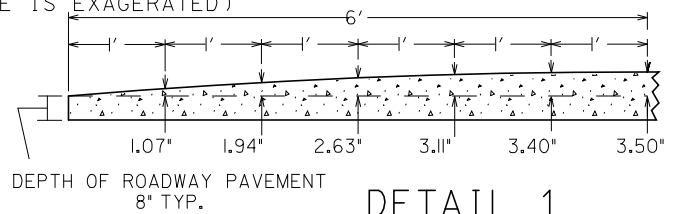

## DETAIL 1

PARABOLIC SURFACE

2008

CITY OF MADISON  
ENGINEERING DIVISION

CONCRETE SPEED HUMP  
RAISED GUTTER

STANDARD DETAIL DRAWING 4.11

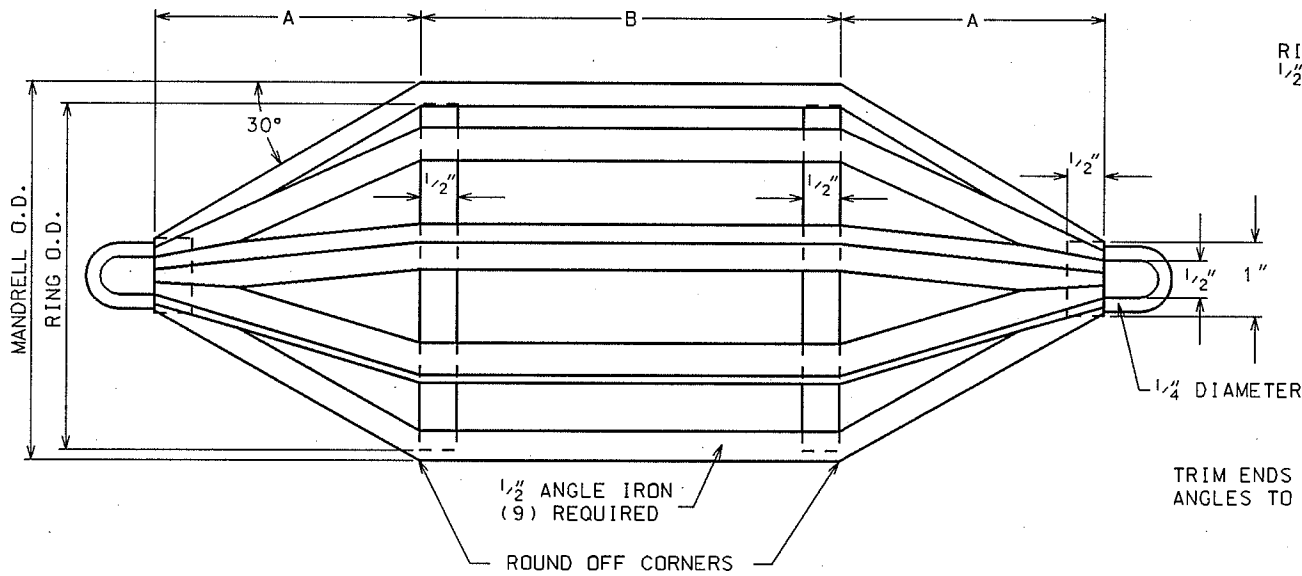

SIDE VIEW

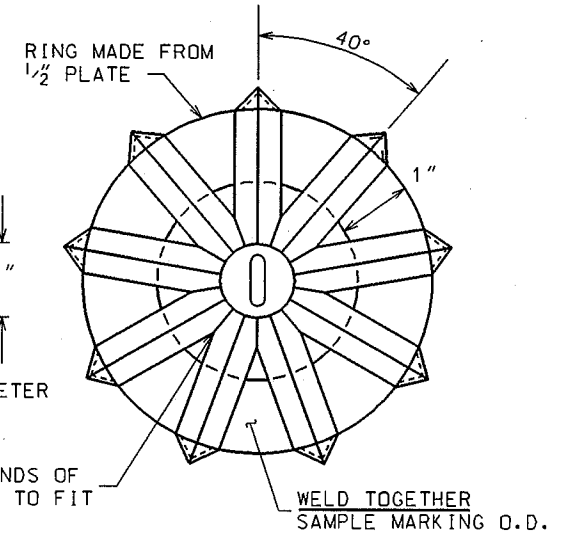

END VIEW

NOMINAL PIPE SIZE ID, in	DIMENSIONS		MANDRELL O.D., in	RING O.D., in
	A, in	B, in		
6	4.0	4	5.61	4.90
8	5.3	6	7.36	6.65
10	6.7	6	9.21	8.50
12	8.0	8	11.06	10.35
15	10.0	9	13.82	13.11

**MANDREL FOR USE IN ALL P.V.C. SEWER PIPE**

**NOTE:**

AFTER CONSTRUCTION IS COMPLETE, TRUE THE O.D. DIMENSION FOR THE FULL LENGTH OF "B" TO +/-0.010" BY TOOL AND LATHE OR GRINDING.

2004

CITY OF MADISON  
ENGINEERING DIVISION

**MANDREL DETAIL**

STANDARD DETAIL DRAWING 5.1.1

ALL REINFORCEMENT SHALL BE EPOXY COATED.

XX IF FALSEWORK IS USED, #6 DOWELS, 12" O.C., SHALL BE PLACED LONGITUDINALLY TO EXTEND 6" INTO EXISTING ROOF. ALL DOWELS SHALL BE GROUTED WITH EPOXY MORTAR.

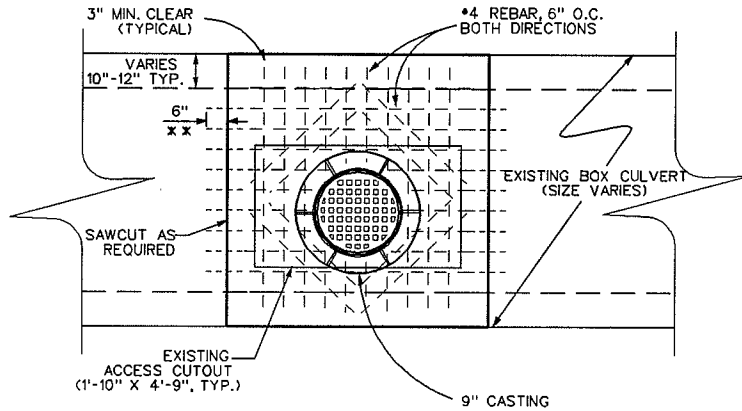

NOTE:  
NEW ROOFS FOR TYPE 1 AND TYPE 2 SHALL BE POURED SEPARATELY FROM THE EXISTING BOX CULVERT UNLESS FALSEWORK IS TO BE UTILIZED FOR TYPE 2 ROOF REPAIRS. NEW ROOFS SHALL BE POURED ON A LEVEL, FLAT SURFACE.

**PATCH RCBC ROOF  
TYPE I & TYPE II  
TOP VIEW**

1" GAP (MAXIMUM) ALLOWABLE SPACING BETWEEN NEW ROOF AND EXISTING ROOF. 8" WIDE 1/4" STEEL PLATE SHALL BE PLACED THE FULL WIDTH OF THE BOX CENTERED ON THE JOINT (TYP.)

NOTE:  
THE OUTSIDE ADJUSTING RINGS SHALL BE SEALED WITH A 1/2" THICK, AIR ENTRAINED MORTAR TYPE M OR S SEAL (TYP.)

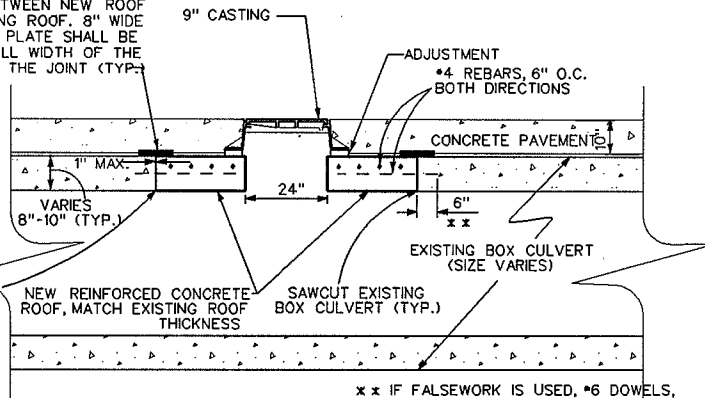

XX IF FALSEWORK IS USED, #6 DOWELS, 12" O.C., SHALL BE PLACED LONGITUDINALLY TO EXTEND 6" INTO EXISTING ROOF. ALL DOWELS SHALL BE GROUTED WITH EPOXY MORTAR.

**TYPE II REPAIR  
SIDE VIEW**

NOTE:  
THE OUTSIDE ADJUSTING RINGS SHALL BE SEALED WITH A 1/2" THICK, AIR ENTRAINED MORTAR TYPE M OR S SEAL (TYP.)

SEALTIGHT COLD PLASTIC SEWER JOINT COMPOUND OR AIR ENTRAINED TYPE M OR S MORTAR (PER THE CITY OF MADISON STANDARD SPECIFICATIONS FOR PUBLIC WORKS CONSTRUCTION) (TYP.)

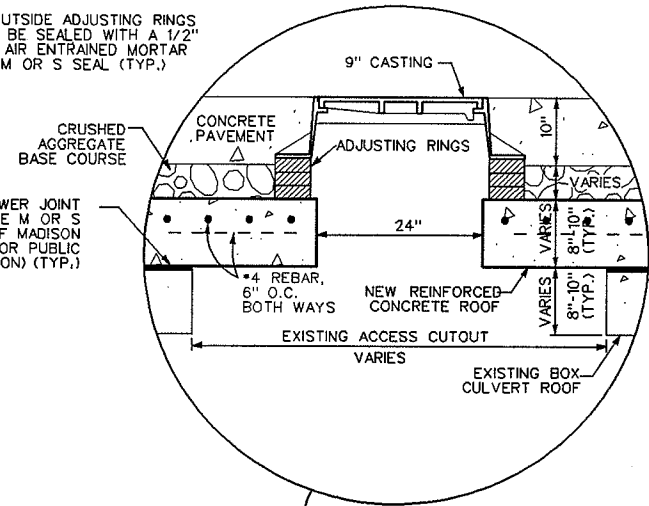

INSET  
INSET

SEALTIGHT COLD PLASTIC SEWER JOINT COMPOUND OR AIR ENTRAINED TYPE M OR S MORTAR (PER THE CITY OF MADISON STANDARD SPECIFICATIONS FOR PUBLIC WORKS CONSTRUCTION) (TYP.)

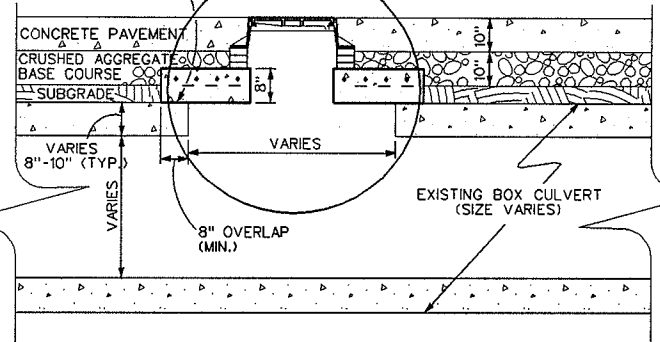

**TYPE I REPAIR  
SIDE VIEW**

2004

CITY OF MADISON  
ENGINEERING DIVISION

RCBC REPAIR  
TYPE I & TYPE II

STANDARD DETAIL DRAWING 5.1.2

5.1.2

5.1.3

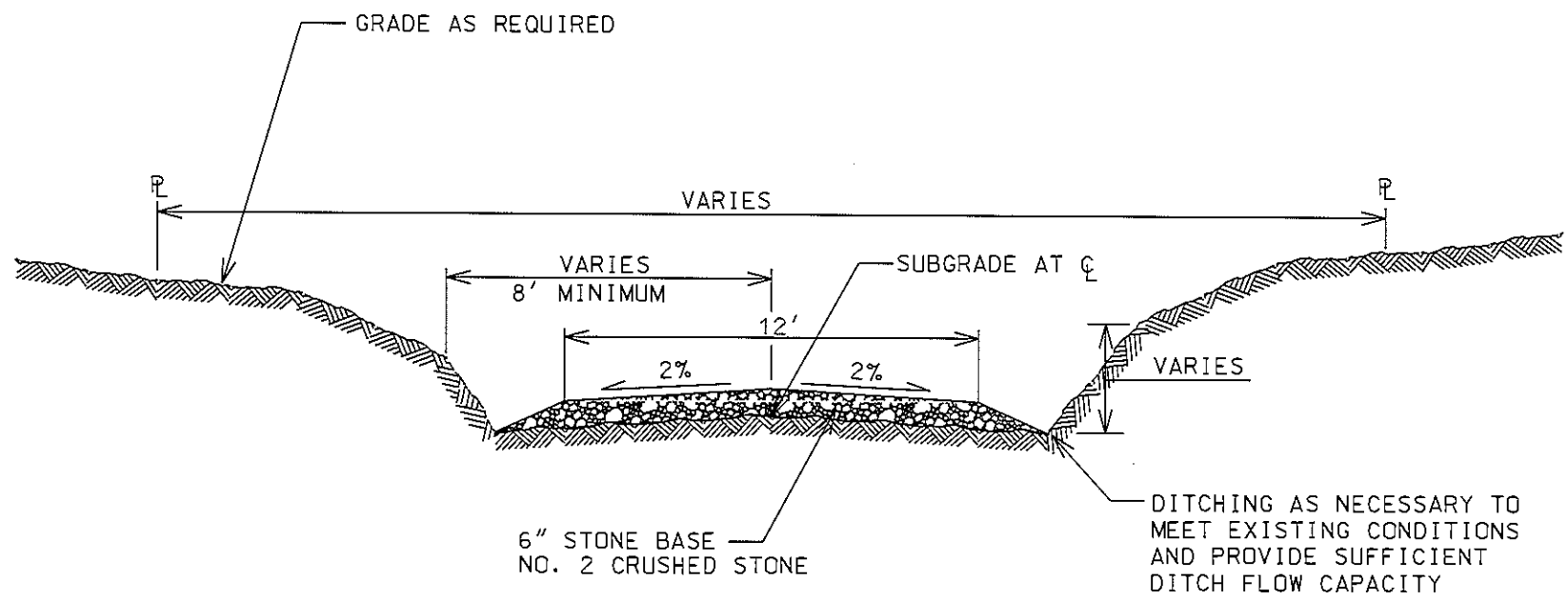

GENERAL NOTES:

SUBGRADE SHALL BE CONSTRUCTED IN ACCORDANCE WITH CITY OF MADISON STANDARD SPECIFICATIONS.

TERRACES AND SIDESLOPES SHALL BE TOPSOILED, SEED, FERTILIZED AND MULCHED IN ACCORDANCE WITH THE SPECIFICATIONS EXCEPT THAT THE DITCH MAY NEED TO BE STONE.

INSTALL CRUSHED STONE DITCHES IF DIRECTED TO BY THE ENGINEER AND DEEPEN THEM AS REQUIRED.

2006

CITY OF MADISON ENGINEERING DIVISION
TYPICAL SECTION SAS ACCESS ROAD TEMPORARY
STANDARD DETAIL DRAWING 5.1.3

5.1.4

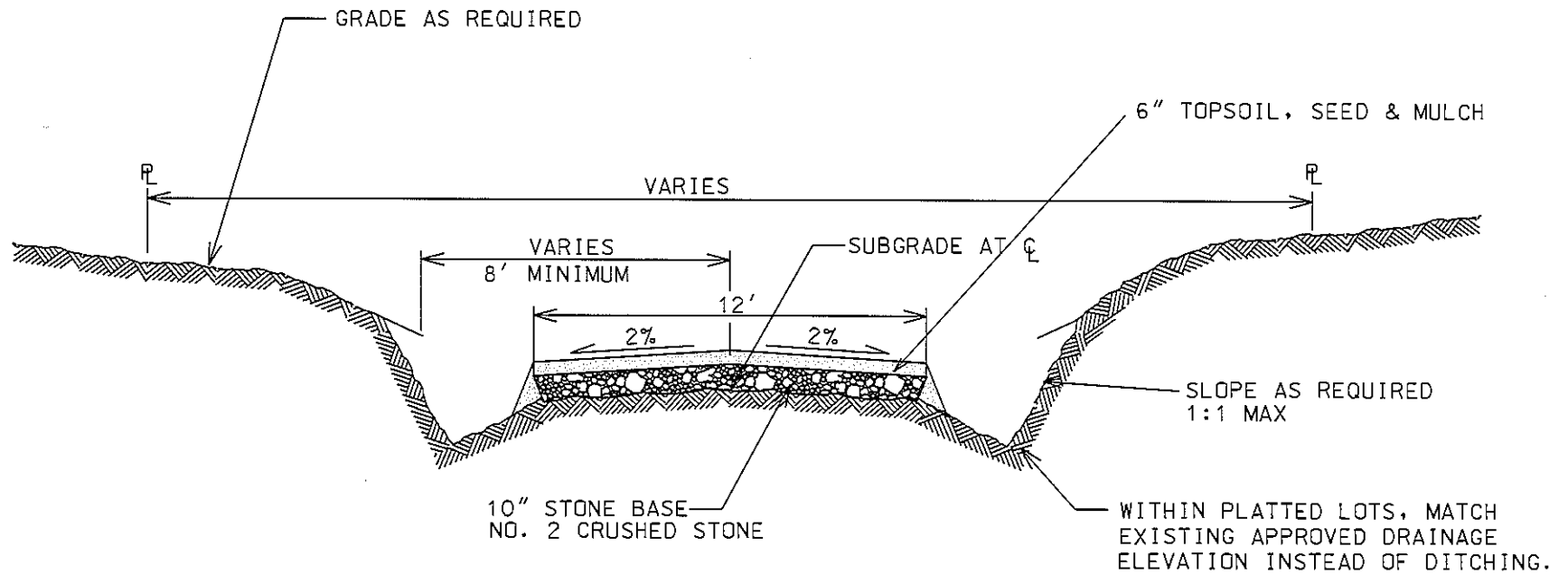

GENERAL NOTES:

SUBGRADE SHALL BE CONSTRUCTED IN ACCORDANCE WITH CITY OF MADISON STANDARD SPECIFICATIONS.

TERRACES AND SIDESLOPES SHALL BE TOPSOILED, SEEDED, FERTILIZED AND MULCHED IN ACCORDANCE WITH THE SPECIFICATIONS EXCEPT THAT THE DITCH MAY REQUIRE 3" CLEAR STONE.

2006

CITY OF MADISON ENGINEERING DIVISION
<b>TYPICAL SECTION SAS ACCESS ROAD PERMANENT</b>
STANDARD DETAIL DRAWING 5.1.4

5.2.1

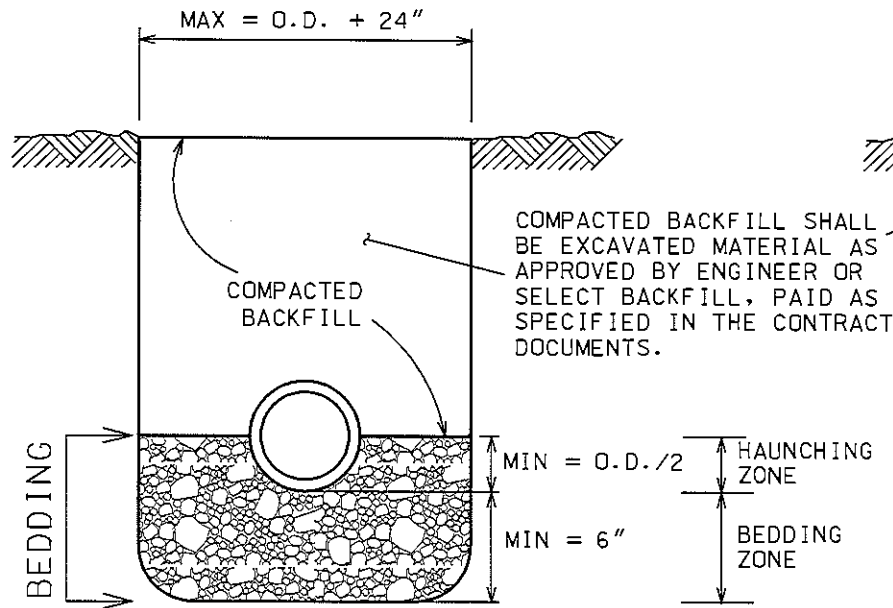

 WASHED GRAVEL OR CRUSHED STONE AS SPECIFIED IN SECTION 502.1 (d), BEDDING OF SEWER PIPES

### BEDDING FOR REINFORCED CONCRETE SEWER PIPES

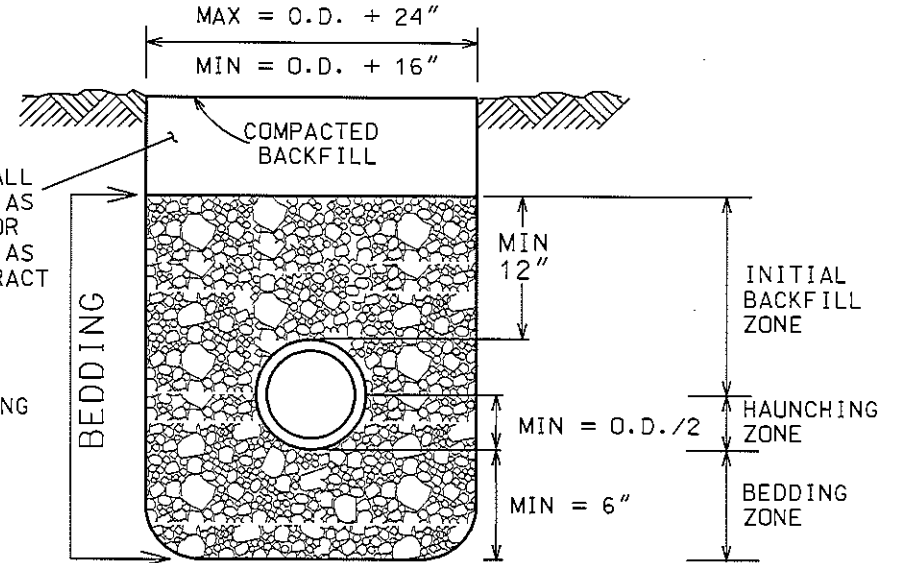

 WASHED GRAVEL, CRUSHED STONE, SAND OR LIMESTONE SCREENINGS FOR PIPE SIZES 10" IN DIAMETER OR LESS. WASHED GRAVEL OR CRUSHED STONE FOR PIPE SIZES OVER 10" IN DIAMETER. AS SPECIFIED IN SECTION 502.1 (d), BEDDING OF SEWER PIPES

### BEDDING FOR SANITARY SEWER PIPES AS WELL AS METAL, ADS, AND PVC STORM PIPES

**NOTES:**

UNLESS OTHERWISE SPECIFIED, ALL SANITARY AND STORM SEWER PIPES, INCLUDING LATERALS AND LEADS, SHALL BE INSTALLED WITH THE TYPE OF BEDDING SHOWN FOR THE TYPE AND SIZE OF PIPE INSTALLED.

THE COSTS OF BEDDING SHALL BE INCLUDED IN THE UNIT PRICES BID FOR THE PIPE. FOR RCP, BEDDING INCLUDES THE HAUNCHING & BEDDING ZONES. FOR PLASTIC PIPES, THE BEDDING INCLUDES THE HAUNCHING, BEDDING & INITIAL BACKFILL ZONES. THE BEDDING SHALL BE INSTALLED & COMPACTED IN 6" MAXIMUM LIFTS.

ALL TRENCHES SHALL BE HAND BACKFILLED TO A POINT 12" ABOVE THE TOP OF THE PIPE. ALL BEDDING SHALL BE MECHANICALLY COMPACTED.

PAYMENT SHALL NOT BE MADE FOR BACKFILL WITH EXCAVATED MATERIAL, IF APPROVED. SELECT FILL, IF REQUIRED, SHALL BE PAID PER CONTRACT.

THE MAXIMUM ALLOWABLE TRENCH WIDTH SHALL BE O.D. + 24" AND MINIMUM OF OD + 16" AS SPECIFIED, AND SHALL APPLY FROM THE BOTTOM OF THE TRENCH TO A POINT 12" ABOVE THE TOP OF THE PIPE. WHERE THIS WIDTH IS EXCEEDED, THE CONTRACTOR SHALL FURNISH AND INSTALL A HIGHER TYPE OF BEDDING AT NO EXTRA COST. THE TYPE OF BEDDING SHALL BE DETERMINED BY THE ENGINEER.

O.D. EQUALS THE OUTSIDE DIAMETER OF THE PIPE.

2006

CITY OF MADISON  
ENGINEERING DIVISION

PIPE BEDDING  
AND BACKFILL

STANDARD DETAIL DRAWING 5.2.1

DRAWING NOT TO SCALE



5.2.1A

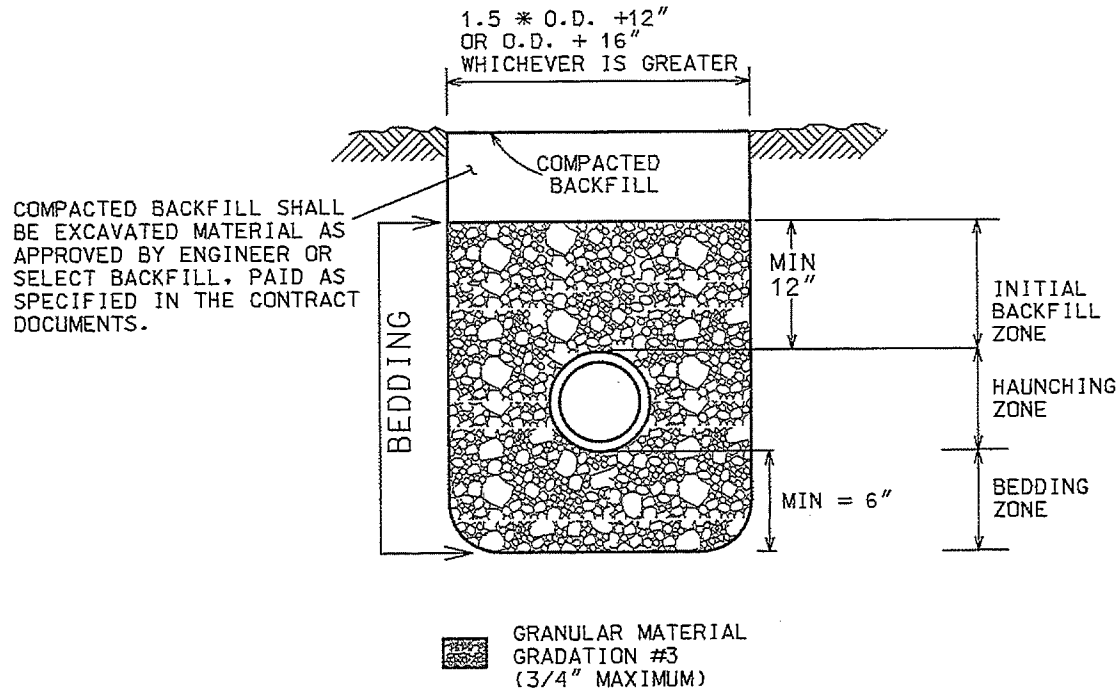

BEDDING FOR  
STORM SEWER PIPE—  
SECTION 1 OF S.D.D 5.2.2

NOTES:

UNLESS OTHERWISE SPECIFIED, ALL HDPE SEWER PIPES, INCLUDING LATERALS AND LEADS, SHALL BE INSTALLED WITH THE TYPE OF BEDDING SHOWN FOR THE TYPE AND SIZE OF PIPE INSTALLED.

BEDDING SHALL BE INSTALLED IN ACCORDANCE WITH ASTM D2321

THE COSTS OF BEDDING SHALL BE INCLUDED IN THE UNIT PRICES BID FOR THE PIPE. THE BEDDING INCLUDES THE HAUNCHING, BEDDING & INITIAL BACKFILL ZONES. THE BEDDING SHALL BE INSTALLED & COMPACTED IN 6" MAXIMUM LIFTS.

ALL TRENCHES SHALL BE HAND BACKFILLED TO A POINT 12" ABOVE THE TOP OF THE PIPE. ALL BEDDING SHALL BE MECHANICALLY COMPACTED.

PAYMENT SHALL NOT BE MADE FOR BACKFILL WITH EXCAVATED MATERIAL, IF APPROVED. SELECT FILL, IF REQUIRED, SHALL BE PAID PER CONTRACT.

THE MAXIMUM ALLOWABLE TRENCH WIDTH SHALL BE THE MIN SPECIFIED PLUS 12". AND SHALL APPLY FROM THE BOTTOM OF THE TRENCH TO A POINT 12" ABOVE THE TOP OF THE PIPE. WHERE THIS WIDTH IS EXCEEDED, THE CONTRACTOR SHALL FURNISH AND INSTALL A HIGHER TYPE OF BEDDING AT NO EXTRA COST. THE TYPE OF BEDDING SHALL BE DETERMINED BY THE ENGINEER.

O.D. EQUALS THE OUTSIDE DIAMETER OF THE PIPE.

2011

CITY OF MADISON ENGINEERING DIVISION
STORM PIPE BEDDING AND BACKFILL— SECTION 1 OF S.D.D.5.2.2.
STANDARD DETAIL DRAWING 5.2.1A

DRAWING NOT TO SCALE

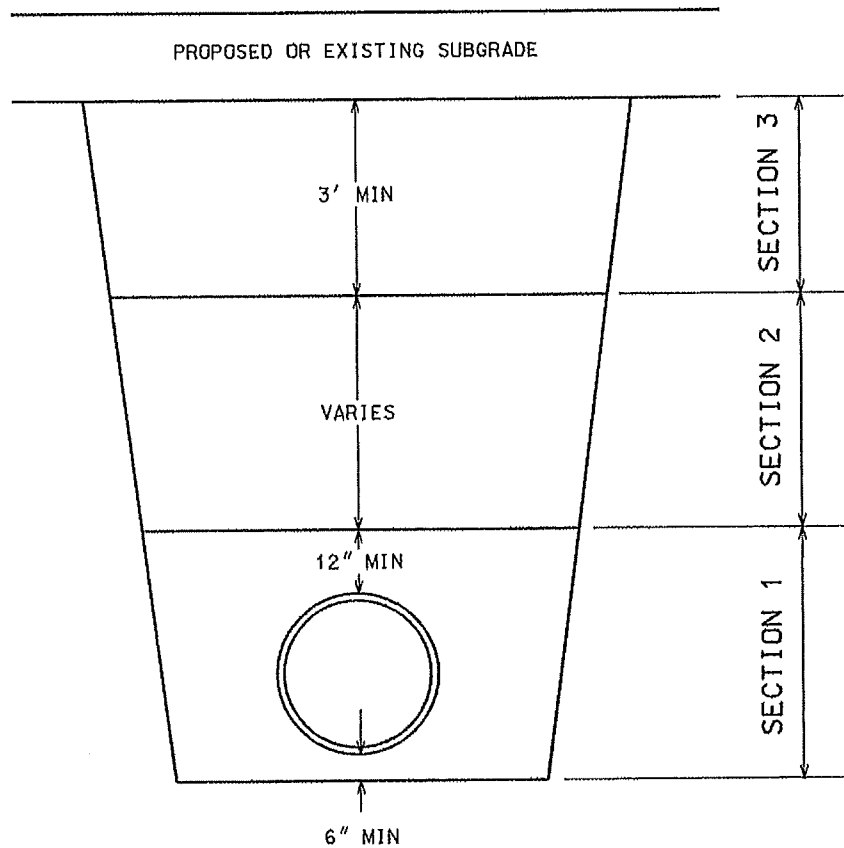

**TYPICAL TRENCH COMPACTION**

ALL BACKFILL MATERIAL SHALL BE PLACED IN LIFTS NOT TO EXCEED 12" BEFORE COMPACTION UNLESS AUTHORIZED BY THE ENGINEER DUE TO THE CHARACTER OF THE MATERIAL AND THE COMPACTING EQUIPMENT. EACH LIFT SHALL BE MECHANICALLY COMPACTED TO THE REQUIRED DENSITY PRIOR TO PLACING SUCCEEDING LIFTS OF BACKFILL MATERIAL.

IN COLD WEATHER, TRENCHES SHALL BE COMPACTED IN ACCORDANCE WITH THE REQUIREMENTS SPECIFIED IN SECTION 502.1 (e), BACKFILLING EXCAVATIONS AND COMPACTION OF BACKFILL, OF THESE SPECIFICATIONS.

**SECTION 1:**

MECHANICALLY COMPACTED BEDDING AS REQUIRED BY THE SPECIFICATIONS. COMPACTION ACHIEVED WITH SMALLER PLATE COMPACTOR. FOR ALL PLASTIC PIPE SECTION 1 SHALL BE INSTALLED IN ACCORDANCE WITH S.D.D. 5.2.1A

**SECTION 2:**

MINIMUM COMPACTION OF 90% MAXIMUM DENSITY. COMPACTION OF BACKFILL WITH BOMAG OR HOE-PAC SHALL NOT BEGIN UNTIL THE DEPTH OF BACKFILL MATERIAL IS TWO FEET ABOVE THE TOP OF PIPE.

**SECTION 3:**

MINIMUM COMPACTION OF 95% MAXIMUM DENSITY.

2011

CITY OF MADISON  
ENGINEERING DIVISION

**TYPICAL  
TRENCH  
COMPACTION**

STANDARD DETAIL DRAWING 5.2.2

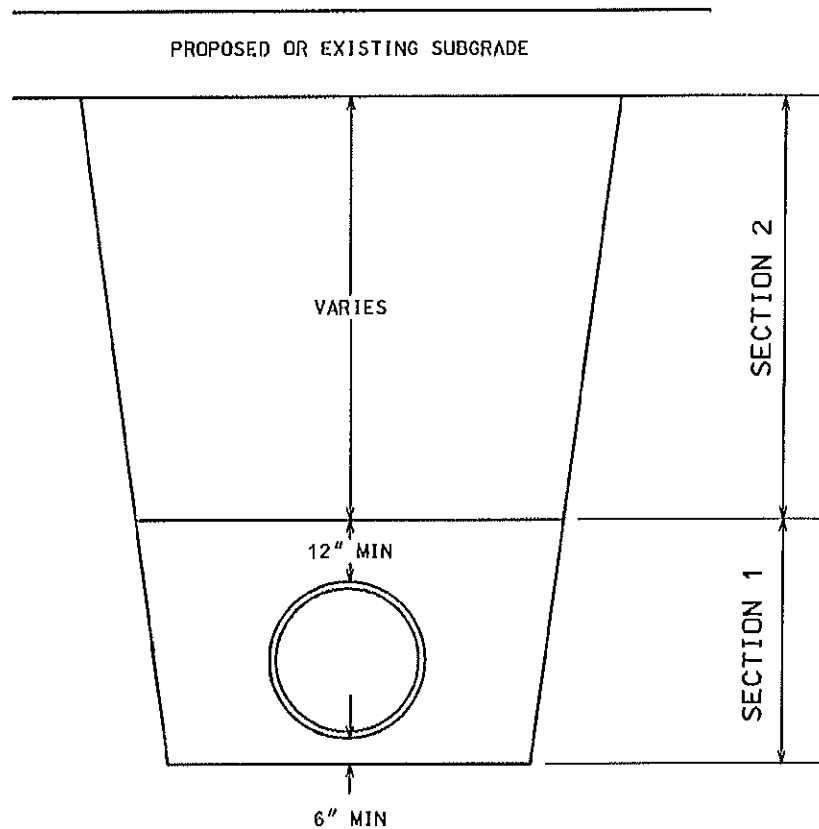

TYPICAL TRENCH COMPACTION (GREENWAY/ PARK)

ALL BACKFILL MATERIAL SHALL BE PLACED IN LIFTS NOT TO EXCEED 12" BEFORE COMPACTION UNLESS AUTHORIZED BY THE ENGINEER DUE TO THE CHARACTER OF THE MATERIAL AND THE COMPACTING EQUIPMENT. EACH LIFT SHALL BE MECHANICALLY COMPACTED TO THE REQUIRED DENSITY PRIOR TO PLACING SUCCEEDING LIFTS OF BACKFILL MATERIAL.

IN COLD WEATHER, TRENCHES SHALL BE COMPACTED IN ACCORDANCE WITH THE REQUIREMENTS SPECIFIED IN SECTION 502.1 (a), BACKFILLING EXCAVATIONS AND COMPACTION OF BACKFILL, OF THESE SPECIFICATIONS.

IF PROPOSED PIPE IS LOCATED HORIZONTALLY WITHIN 15' OF AN EXISTING OR PROPOSED ASPHALT OR CONCRETE SURFACE, THEN THE PIPE TRENCH COMPACTION SHALL BE COMPLETED IN CONFORMANCE OF S.O.D. 5.2.2

SECTION 1:

MECHANICALLY COMPACTED BEDDING AS REQUIRED BY THE SPECIFICATIONS. COMPACTION ACHIEVED WITH SMALLER PLATE COMPACTOR.

SECTION 2:

MINIMUM COMPACTION OF 90% MAXIMUM DENSITY. COMPACTION OF BACKFILL WITH BOMAG OR HOE-PAC SHALL NOT BEGIN UNTIL THE DEPTH OF BACKFILL MATERIAL IS TWO FEET ABOVE THE TOP OF PIPE.

2009

CITY OF MADISON  
ENGINEERING DIVISION

TYPICAL TRENCH  
COMPACTION  
(GREENWAY/PARK)

STANDARD DETAIL DRAWING 5.2.3

**TYPE I**  
CONCRETE PAVEMENT

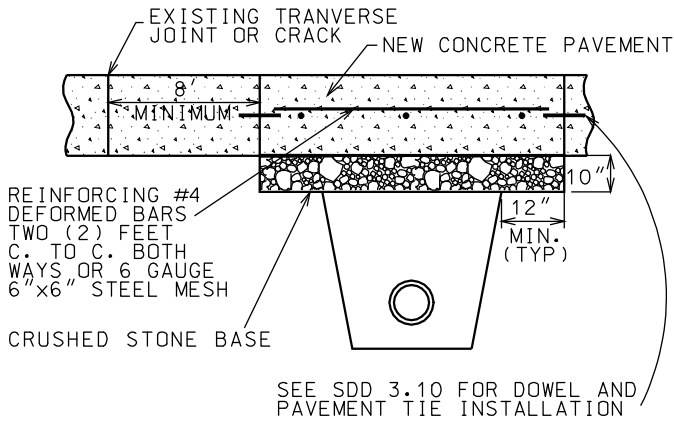

**TYPE I UTILITY TRENCH PATCH**

THE PAVEMENT SHALL BE REMOVED IN TWO STAGES. THE INITIAL PAVEMENT REMOVAL SHALL BE LIMITED TO THE AREA OF THE PROPOSED TRENCH. FULL-DEPTH SAWCUTTING WILL NOT BE REQUIRED FOR THIS PHASE OF THE PAVEMENT REMOVAL. AFTER THE TRENCH HAS BEEN BACKFILLED AND COMPACTED, AND AFTER THE BASE HAS BEEN RESTORED IN THE AREA OF THE TRENCH, AND AFTER SAWCUTTING THE NEW JOINTS THE FULL DEPTH OF THE EXISTING PAVEMENT (INCIDENTAL), THE REMAINING PAVEMENT TO BE REMOVED SHALL BE REMOVED WITHOUT DISTURBING THE EXISTING BASE.

THE SIZE OF THE PATCH SHALL BE DETERMINED BY THE TOP WIDTH OF THE TRENCH, THE LOCATION AND SKEW OF THE EXISTING TRANSVERSE JOINTS, THE CONDITION OF THE EXISTING PAVEMENT, AND THE CONDITION OF THE BASE. NEW TRANSVERSE JOINTS SHALL BE PARALLEL TO THE EXISTING TRANSVERSE JOINTS, AND SHALL BE A MINIMUM OF ONE (1) FOOT FROM THE TRENCH. THE DISTANCE BETWEEN NEW AND EXISTING TRANSVERSE JOINTS SHALL BE A MINIMUM OF EIGHT (8) FEET, MEASURED PERPENDICULAR TO THE JOINTS. THE PATCH SHALL BE A MINIMUM OF EIGHT (8) FEET IN LENGTH, AND SHALL HAVE THE SAME WIDTH AS THE PAVEMENT LANE.

THE PATCH SHALL BE NINE (9) INCHES IN THICKNESS OF HIGH EARLY STRENGTH CONCRETE, DOWELED AND TIED WITH EPOXY COATED BARS, AND REINFORCED, ALL IN ACCORDANCE WITH THE TYPICAL SECTION.

THE TRANSVERSE EDGES OF THE FINISHED PATCH SHALL BE FLUSH WITH THE EDGES OF THE EXISTING CONCRETE PAVEMENT. THE LONGITUDINAL SURFACE SHALL FORM A STRAIGHT LINE FROM EDGE TO EDGE WITHIN A TOLERANCE OF 1/8 INCH.

**TYPE II**  
CONCRETE WITH ASPHALTIC OVERLAY

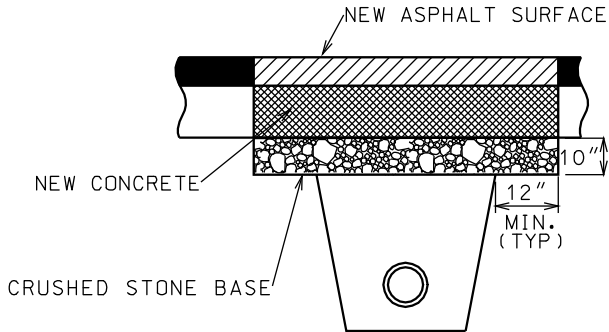

**TYPE II UTILITY TRENCH PATCH**

THE PATCH SHALL BE 7" HIGH EARLY STRENGTH CONCRETE BASE WITH THE SAME REINFORCEMENT AS THE EXISTING CONCRETE BASE, OVERLAID WITH ASPHALT UPPER LAYER, WHERE SPECIFIED, OR DIRECTED BY THE ENGINEER. THE BASE SHALL BE CONSTRUCTED OF ASPHALTIC BASE COURSE MATERIAL, SHALL BE THE SAME THICKNESS AS THE EXISTING BASE, AND SHALL BE LAID IN TWO OR MORE COMPACTED LIFTS OF NOT MORE THAN 3" IN THICKNESS EACH.

THE PAVEMENT ALONG THE PATCH SHALL BE SAWCUT, FULL DEPTH, AND INCIDENTAL TO THE TRENCH PATCH. THE EDGES OF THE PATCH SHALL BE VERTICAL, FREE OF LOOSE STONES OR CONCRETE PIECES, AND SHALL BE THOROUGHLY WETTED JUST PRIOR TO POURING THE NEW CONCRETE BASE.

THE TOP OF THE NEW CONCRETE OR ASPHALT BASE SHALL BE FLUSH WITH THE TOP OF THE EXISTING CONCRETE BASE.

PRIOR TO PLACING THE ASPHALT UPPER LAYER, THE EDGES OF THE PATCH AND THE SURFACE OF THE NEW CONCRETE BASE SHALL BE THOROUGHLY TACKED WITH LIQUID ASPHALT.

THE ASPHALT UPPER LAYER SHALL BE OF THE SAME THICKNESS AS THE EXISTING ASPHALT OVERLAY WITH A MINIMUM THICKNESS OF 3" AND A MAXIMUM THICKNESS OF 5 1/4" UNLESS OTHERWISE SPECIFIED AND SHALL BE LAID IN ONE OR MORE COURSES AS DIRECTED BY THE ENGINEER. THE ASPHALTIC UPPER LAYER SHALL BE MACHINE LAID WHERE DIRECTED BY THE ENGINEER. WHERE THE ASPHALTIC UPPER LAYER IS MACHINE LAID, AND IS NOT MORE THAN 3" IN THICKNESS, THE ASPHALTIC SURFACE MAY BE LAID IN ONE LIFT.

**TYPE III**  
ASPHALTIC STREET

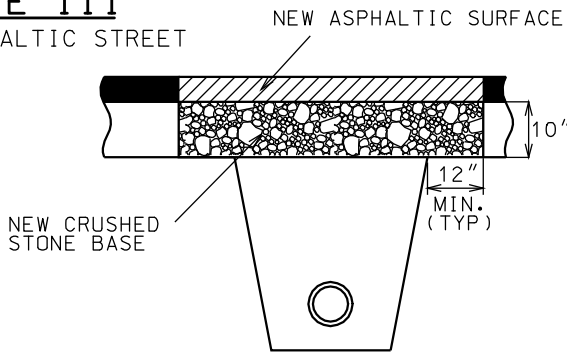

**TYPE III UTILITY TRENCH PATCH**

THE PATCH SHALL BE CRUSHED STONE BASE COURSE, GRADATION NO. 2 OVERLAID WITH ASPHALT UPPER LAYER EQUAL IN THICKNESS TO THE EXISTING ASPHALTIC PAVEMENT, WITH A MINIMUM THICKNESS OF 3" AND A MAXIMUM THICKNESS OF 5 1/4" UNLESS OTHERWISE SPECIFIED AND LAID IN ONE OR MORE COURSES AS DIRECTED BY THE ENGINEER.

THE PAVEMENT ALONG THE PATCH SHALL BE SAWCUT, FULL DEPTH, AND INCIDENTAL TO THE TRENCH PATCH. THE EDGES OF THE EXISTING ASPHALTIC PAVEMENT SHALL BE FREE OF LOOSE STONES OR PAVEMENT MATERIAL.

THE CRUSHED STONE BASE COURSE SHALL BE INSTALLED IN TWO LIFTS. THE LOWER LIFT SHALL BE THOROUGHLY MECHANICALLY COMPACTED PRIOR TO PLACING THE UPPER LIFT.

THE ASPHALT UPPER LAYER SHALL BE LAID IN TWO LIFTS. THE ASPHALT UPPER LAYER SHALL BE MACHINE LAID WHERE DIRECTED BY THE ENGINEER. WHERE THE ASPHALTIC UPPER LAYER IS MACHINE LAID AND IS NOT MORE THAN 3" IN THICKNESS, THE ASPHALT SURFACE COURSE MAY BE IN ONE LIFT.

PRIOR TO PLACING THE ASPHALT UPPER LAYER, THE EDGES OF THE PATCH AND THE SURFACE OF THE CRUSHED STONE BASE SHALL BE TACKED AND PRIMED WITH LIQUID ASPHALT.

**TYPE IV**  
NEW CRUSHED STONE PAVEMENT

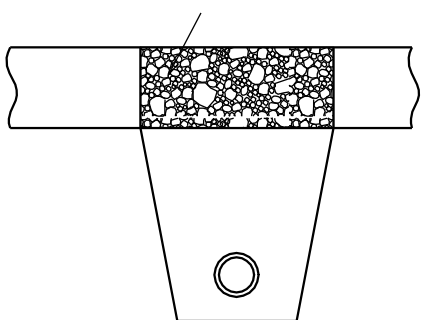

**TYPE IV UTILITY TRENCH PATCH**

THE PATCH SHALL BE 9" CRUSHED STONE BASE COURSE, GRADATION NO. 2. FULL DEPTH SAWCUTTING OF ADJACENT PAVEMENT (IF ANY) SHALL BE CONSIDERED INCIDENTAL TO THE TRENCH PATCH.

THE CRUSHED STONE BASE COURSE SHALL BE INSTALLED IN THREE LIFTS. EACH LIFT SHALL BE THOROUGHLY MECHANICALLY COMPACTED PRIOR TO PLACING SUCCEEDING LIFTS.

CITY OF MADISON  
ENGINEERING DIVISION

TYPICAL PAVEMENT  
PATCH SECTIONS

**RISER DETAIL**

LATERAL AND RECONNECT SHALL CONFORM TO STANDARD SPECIFICATIONS

BEDDING MATERIAL AND DIMENSIONS PER CITY OF MADISON STANDARD SPECIFICATIONS (STANDARD DETAIL DRAWING 5.2.1)

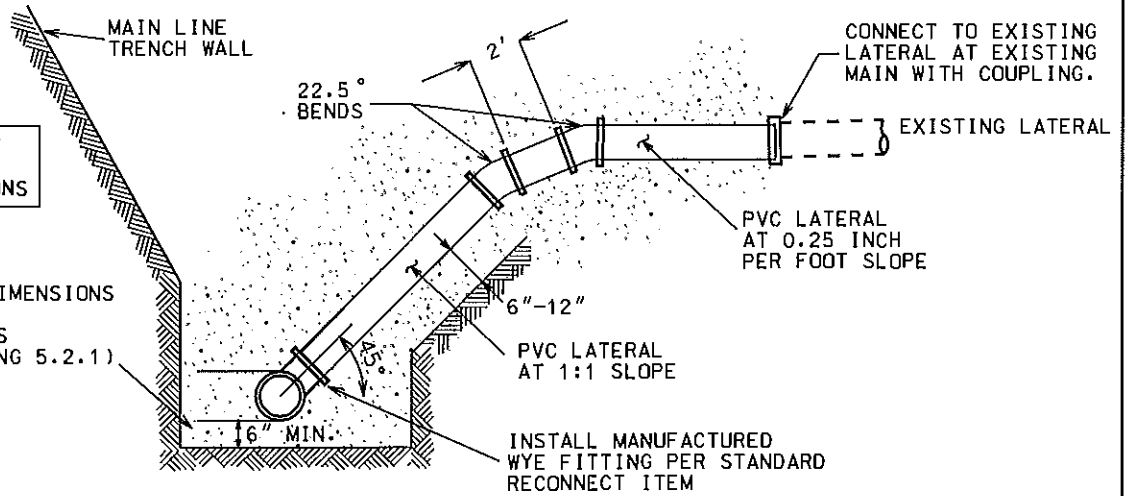

**ALTERNATE METHOD A**

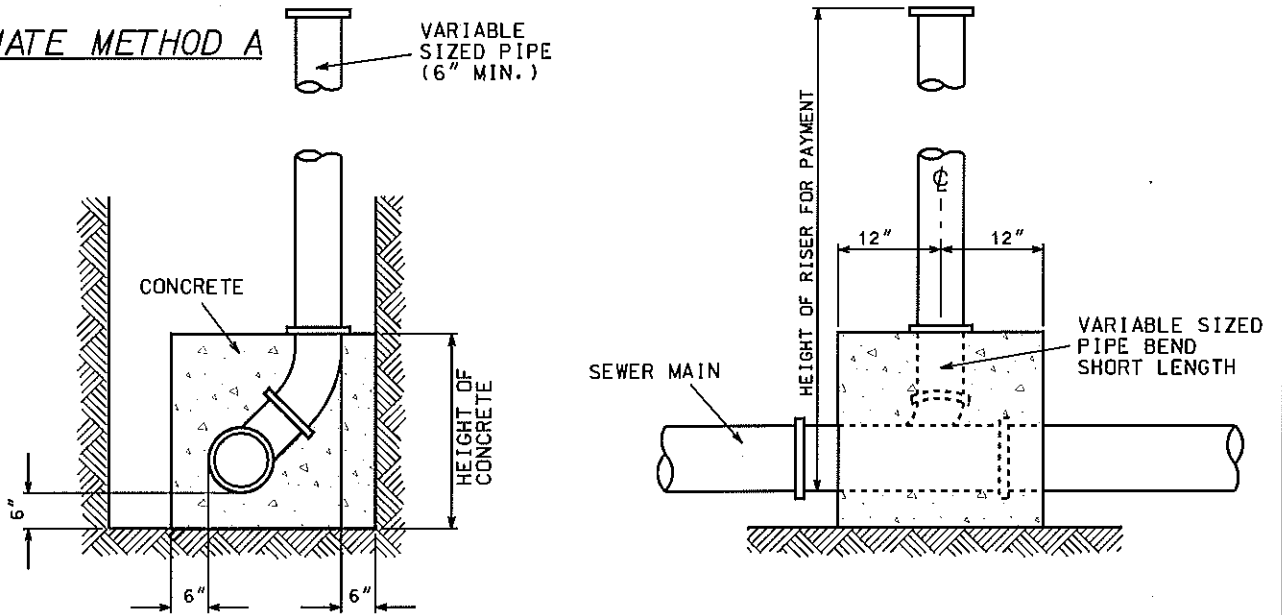

**ALTERNATE METHOD B**

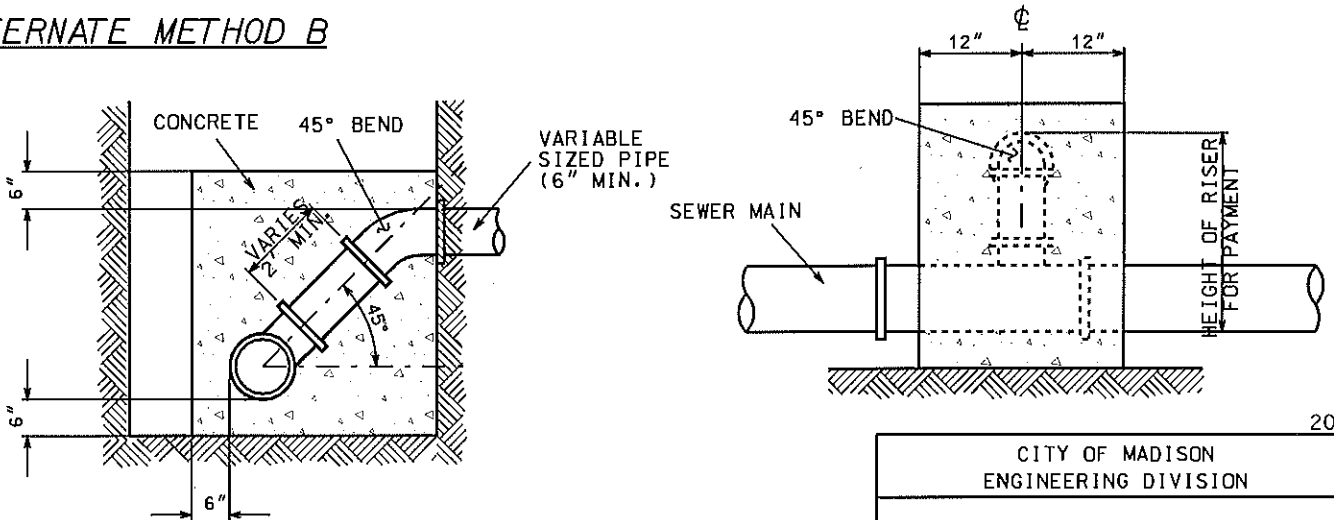

2006

CITY OF MADISON  
ENGINEERING DIVISION

**RISER DETAIL**

STANDARD DETAIL DRAWING 5.3.1

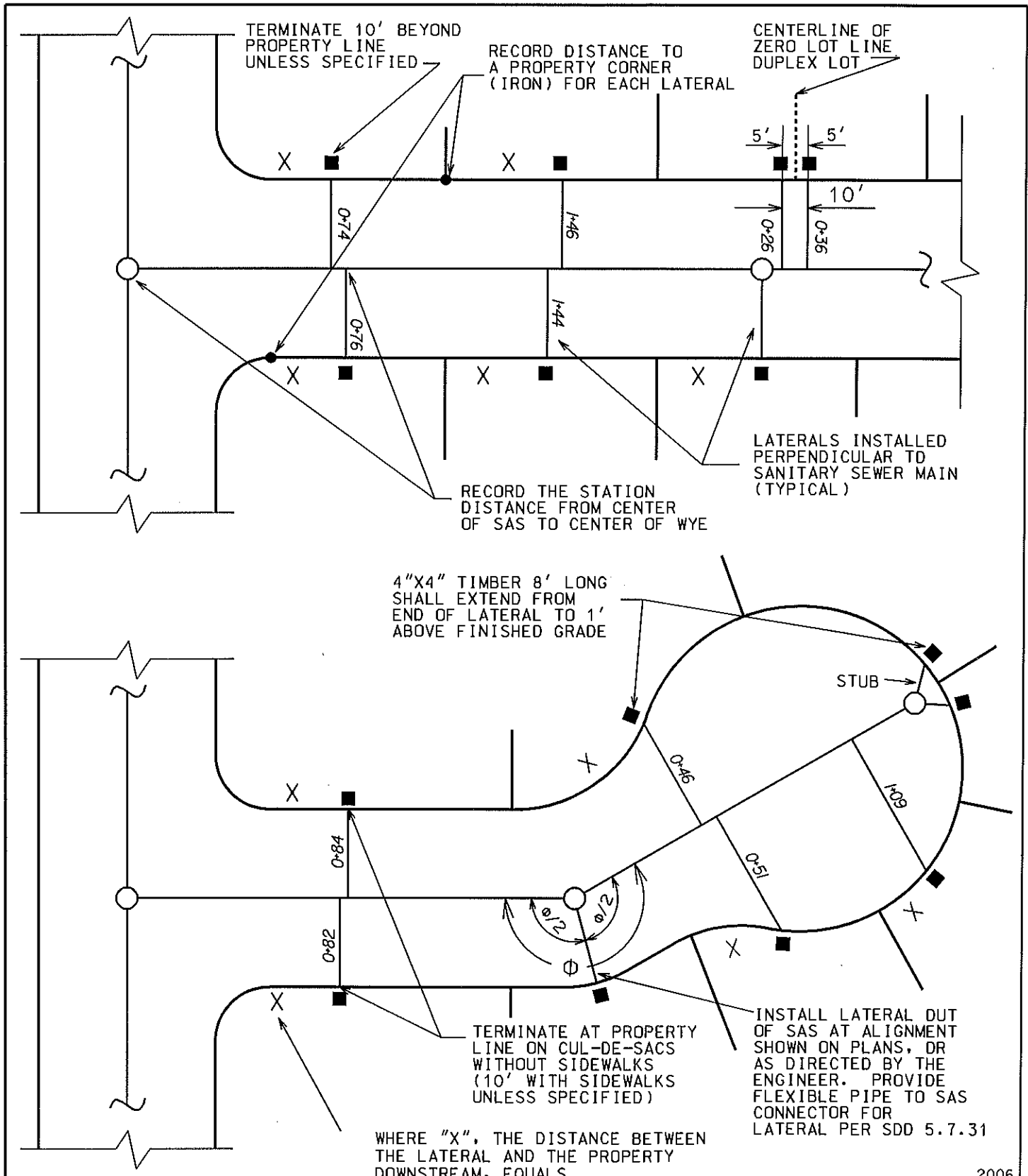

TERMINATE 10' BEYOND PROPERTY LINE UNLESS SPECIFIED

RECORD DISTANCE TO A PROPERTY CORNER (IRON) FOR EACH LATERAL

CENTERLINE OF ZERO LOT LINE DUPLEX LOT

5' 5' 10'

0+26 0+36

0+74

1+46

0+76

1+44

LATERALS INSTALLED PERPENDICULAR TO SANITARY SEWER MAIN (TYPICAL)

RECORD THE STATION DISTANCE FROM CENTER OF SAS TO CENTER OF WYE

4"X4" TIMBER 8' LONG SHALL EXTEND FROM END OF LATERAL TO 1' ABOVE FINISHED GRADE

STUB

0+84

0+82

0+46

0+51

1+09

TERMINATE AT PROPERTY LINE ON CUL-DE-SACS WITHOUT SIDEWALKS (10' WITH SIDEWALKS UNLESS SPECIFIED)

INSTALL LATERAL OUT OF SAS AT ALIGNMENT SHOWN ON PLANS, OR AS DIRECTED BY THE ENGINEER. PROVIDE FLEXIBLE PIPE TO SAS CONNECTOR FOR LATERAL PER SDD 5.7.31

WHERE "X", THE DISTANCE BETWEEN THE LATERAL AND THE PROPERTY DOWNSTREAM, EQUALS

2006

LOT WIDTH -10'  
2

CITY OF MADISON  
ENGINEERING DIVISION

LOCATION OF  
SANITARY LATERALS

STANDARD DETAIL DRAWING 5.3.2

NOTE:  
ALL SANITARY SEWER LATERALS SHALL INCLUDE SANITARY LATERAL MARKER DISKS ABOVE THE LATERAL AT THE WYE & AT THE PROPERTY LINE.

UNLESS OTHERWISE SPECIFIED ON THE PLAN OR DIRECTED BY THE ENGINEER

COMPRESSION COUPLING

PIPES WITH DIFFERENT MATERIAL TYPES  
PIPES WITH DIFFERENT OUTSIDE DIAMETERS

GASKETED REPAIR COUPLING

PVC TO PVC CONNECTION

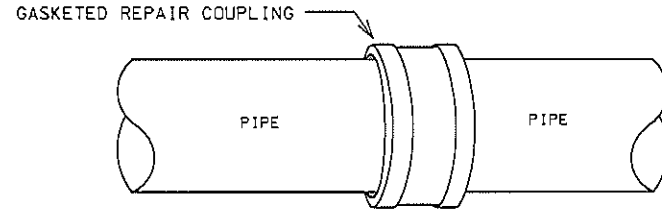
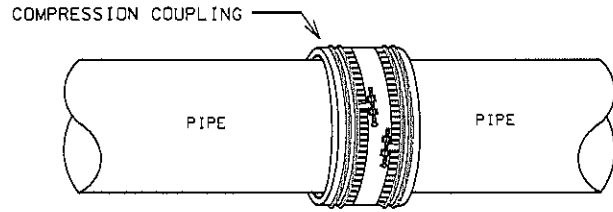

5.3.3

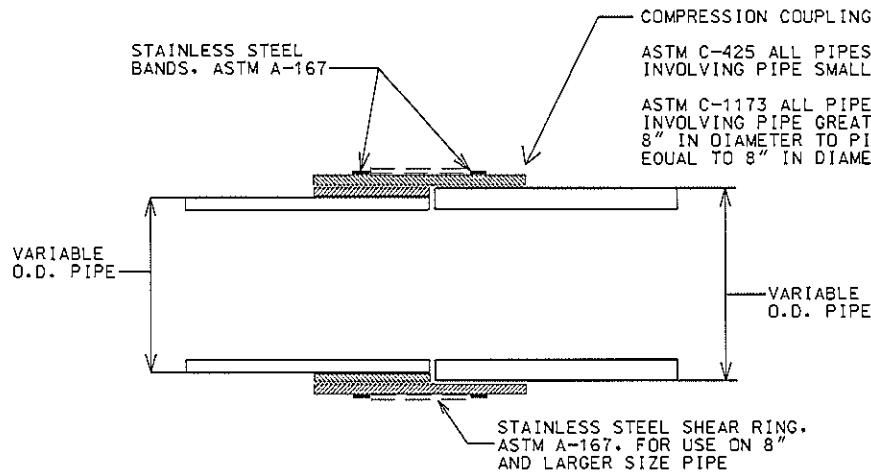

COMPRESSION COUPLING, CONFORMING TO:  
ASTM C-425 ALL PIPES REPAIR CONNECTIONS INVOLVING PIPE SMALLER THAN 8" IN DIAMETER.  
ASTM C-1173 ALL PIPE REPAIR CONNECTIONS INVOLVING PIPE GREATER THAN OR EQUAL TO 8" IN DIAMETER TO PIPES GREATER OR THAN EQUAL TO 8" IN DIAMETER

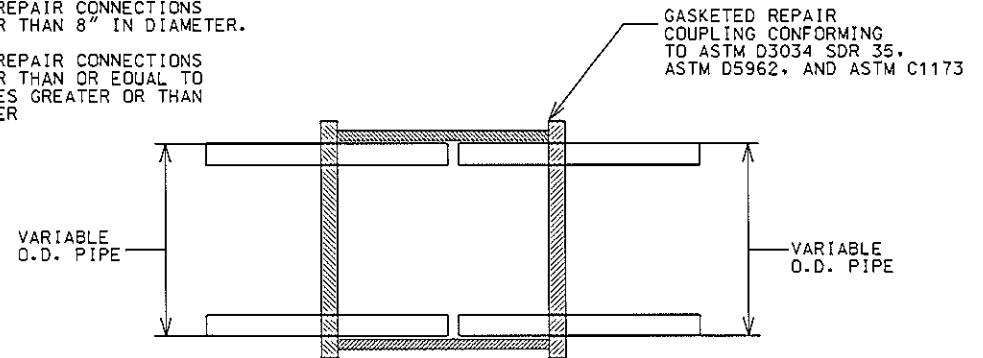

ALL REPAIRS INVOLVING PIPE CONNECTIONS 8" IN DIAMETER TO 8" IN DIAMETER OR LARGER SHALL UTILIZE THE FERNCO RC STRONGBACK OR EQUIVALENT REPAIR COUPLING. (ASTM C1173).

2012

CITY OF MADISON  
ENGINEERING DIVISION

COUPLING  
DETAILS

STANDARD DETAIL DRAWING 5.3.3

### REINFORCED CONCRETE APRON ENDWALLS

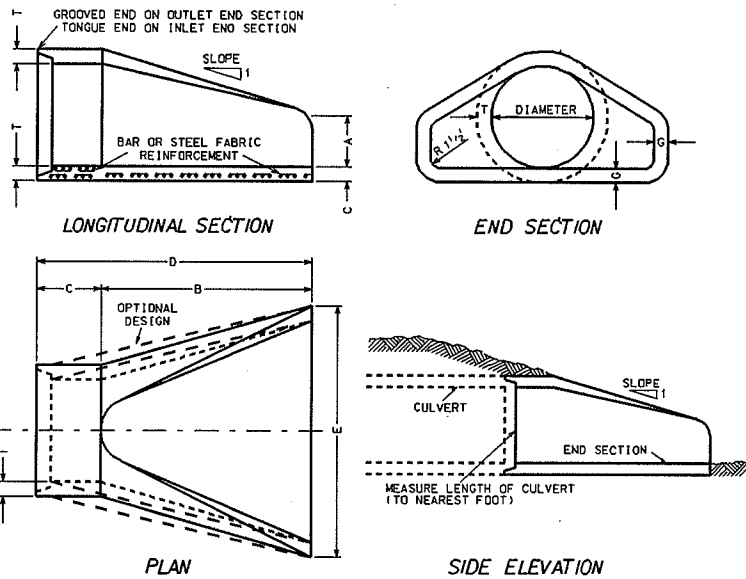

DIA	APPROX. WEIGHT/SECTION	T	A	B	C	D	E	G	APPROX. SLOPE
12"	530	2"	4"	24"	48 1/2"	72 1/2"	24"	2"	3 TO 1
15"	740	2 1/2"	6"	27"	46"	73"	30"	2 1/4"	3 TO 1
18"	990	2 1/2"	9"	27"	46"	73"	36"	2 1/2"	3 TO 1
21"	1280	2 3/4"	9"	36"	37 1/2"	73 1/2"	42"	2 3/4"	3 TO 1
24"	1520	3"	9 1/2"	43 1/2"	30"	73 1/2"	48"	3"	3 TO 1
27"	1930	3 1/2"	10 1/2"	49 1/2"	24"	73 1/2"	54"	3 1/4"	3 TO 1
30"	2190	3 1/2"	12"	54"	19 3/4"	73 3/4"	60"	3 1/2"	3 TO 1
36"	4100	4"	15"	63"	34 3/4"	97 3/4"	72"	4"	3 TO 1
42"	5380	4 1/2"	21"	63"	35"	98"	78"	4 1/2"	3 TO 1
48"	6550	5"	24"	72"	26"	98"	84"	5"	3 TO 1
54"	8040	5 1/2"	27"	65"	33 1/4"/35"	98 1/2"/100"	90"	5"	2 1/2 TO 1
60"	8730	6"	30"/35"	60"	39"	99"	96"	5"	2 TO 1
66"	10630	6 1/2"	24"/30"	72"/78"	21"/27"	99"	102"	5 1/2"	2 TO 1
72"	12520	7"	24"/36"	78"	21"	99"	108"	6"	2 TO 1
78"	14430	7 1/2"	24"/36"	78"	21"	99"	114"	6 1/2"	2 TO 1
84"	18160	8"	36"	90 1/2"	21"	111 1/2"	120"	6 1/2"	1 1/2 TO 1

NOTE: MINIMUM/MAXIMUM

#### GENERAL NOTES:

DETAILS OF CONSTRUCTION, MATERIALS, AND WORKMANSHIP NOT SHOWN ON THIS DRAWING SHALL CONFORM TO THE PERTINENT REQUIREMENTS OF THE STANDARD SPECIFICATIONS AND THE APPLICABLE SPECIAL PROVISIONS.

VARIATIONS OF THE DIMENSIONS AND DESIGNS SHOWN BEFORE WILL BE PERMITTED PROVIDING EQUIVALENT CAPACITY AND STRUCTURAL INTEGRITY ARE ATTAINED, AND PRIOR APPROVAL OF THE ENGINEER IS OBTAINED.

CONCRETE CULVERT ENDWALLS MAY NOT BE USED WITH GALVANIZED STEEL OR ALUMINUM CULVERT PIPE OR VICE VERSA.

GALVANIZED STEEL OR ALUMINUM ENDWALLS SHALL NORMALLY BE INSTALLED ON CULVERT PIPE OF THE SAME METAL. THE USE OF GALVANIZED STEEL ENDWALLS ON ALUMINUM PIPES IS PERMITTED, PROVIDED THE TWO METALS AT THE JOINT INTERFACE ARE KEPT SEPARATED BY A SUITABLE INSULATING MATERIAL APPROXIMATELY 1/8" THICK OR GREATER. SUCH MATERIAL WOULD BE AN ASPHALT IMPREGNATED FABRIC, A SHEET PLASTIC, A RUBBER GASKET OR OTHER NONBIODEGRADABLE MATERIAL OF SUBSTANTIAL STRENGTH.

WHEN TWO OR MORE PIPE ARCHES WITH APRON ENDWALLS ARE TO BE LAID ADJACENT TO EACH OTHER, THEY SHALL BE SEPARATED BY THE FOLLOWING AMOUNT.  
 PIPES: TOTAL WIDTH OF APRON ENDWALL LESS THE DIAMETER OF PIPE PLUS 6 INCHES.  
 PIPE ARCHES: TOTAL WIDTH OF APRON ENDWALL LESS THE SPAN DIMENSION OF THE PIPE ARCH PLUS 6 INCHES.

### METAL APRON ENDWALLS FOR PIPE ARCHES

PIPE-ARCH DIMENSIONS SPAN   RISE	MIN. METAL THICK	DIMENSIONS					APPROX. SLOPE	
		A +/-1"	B MAX	H +/-1"	L +/-1 1/2"	W +/-2"		
17"	13"	0.064	7"	9"	6"	19"	31"	2 1/2 TO 1
21"	15"	0.064	7"	10"	6"	23"	26"	2 1/2 TO 1
24"	18"	0.064	8"	12"	6"	28"	42"	2 1/2 TO 1
28"	20"	0.064	9"	14"	6"	32"	48"	2 1/2 TO 1
35"	24"	0.079	10"	16"	6"	39"	60"	2 1/2 TO 1
42"	29"	0.079	12"	18"	8"	46"	75"	2 1/2 TO 1
49"	33"	0.109	13"	21"	9"	53"	85"	2 1/2 TO 1
57"	38"	0.109	18"	26"	12"	63"	90"	2 1/2 TO 1
64"	43"	0.109	18"	30"	12"	70"	102"	2 1/2 TO 1
71"	47"	0.109	18"	33"	12"	77"	114"	2 1/2 TO 1
77"	52"	0.109	18"	36"	12"	77"	126"	2 TO 1
83"	57"	0.109	18"	39"	12"	77"	138"	2 TO 1

NOTE: ALL SPLICES TO BE LAP RIVETED OR BOLTED

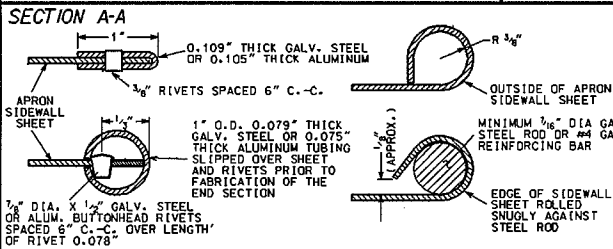
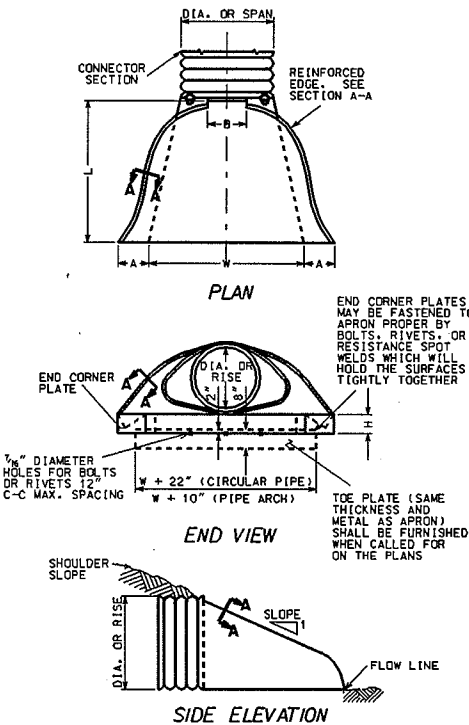

### METAL OR ALUMINUM APRON ENDWALLS FOR CIRCULAR PIPES

DIA	MIN. METAL THICKNESS	MIN. ALUM THICKNESS	DIMENSIONS					APPROX. SLOPE
			A +/-1"	B MAX	H +/-1"	L +/-1 1/2"	W +/-2"	
12"	0.064	0.060	6"	6"	6"	21"	24"	2 1/2 TO 1
15"	0.064	0.060	7"	8"	6"	26"	30"	2 1/2 TO 1
18"	0.064	0.060	8"	10"	6"	31"	36"	2 1/2 TO 1
21"	0.064	0.060	9"	12"	6"	36"	42"	2 1/2 TO 1
24"	0.064	0.075	10"	13"	6"	41"	48"	2 1/2 TO 1
30"	0.079	0.105	12"	16"	8"	51"	60"	2 1/2 TO 1
36"	0.079	0.105	14"	19"	9"	60"	72"	2 1/2 TO 1
42"	0.109	0.105	16"	22"	11"	69"	84"	2 1/2 TO 1
48"	0.109	0.105	18"	27"	12"	78"	90"	2 1/2 TO 1
54"	0.109	0.105	18"	30"	12"	84"	102"	2 TO 1
60"	0.109	N/A	18"	33"	12"	87"	114"	1 3/4 TO 1
66"	0.109	N/A	18"	36"	12"	87"	120"	1 1/2 TO 1
72"	0.109	N/A	18"	39"	12"	87"	126"	1 1/2 TO 1
78"	0.109	N/A	18"	42"	12"	87"	132"	1 1/4 TO 1
84"	0.109	N/A	18"	45"	12"	87"	138"	1 1/4 TO 1

NOTE: ALL SPLICES TO BE LAP RIVETED OR BOLTED

#### CONNECTION DETAILS

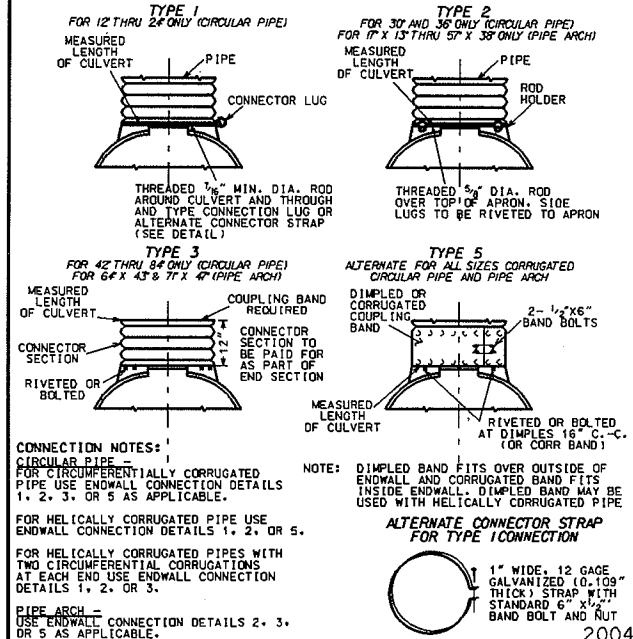

CITY OF MADISON  
ENGINEERING DIVISION

## APRON ENDWALLS FOR PIPES AND PIPE ARCHES

STANDARD DETAIL DRAWING 5.4.1



ENERGY DISSIPATORS TO BE INSTALLED ONLY WHEN DIRECTED BY THE DESIGN ENGINEER

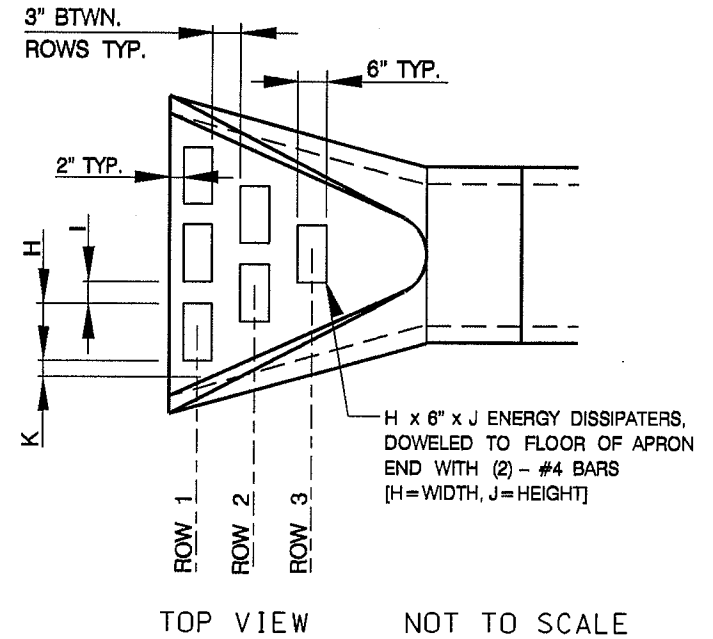
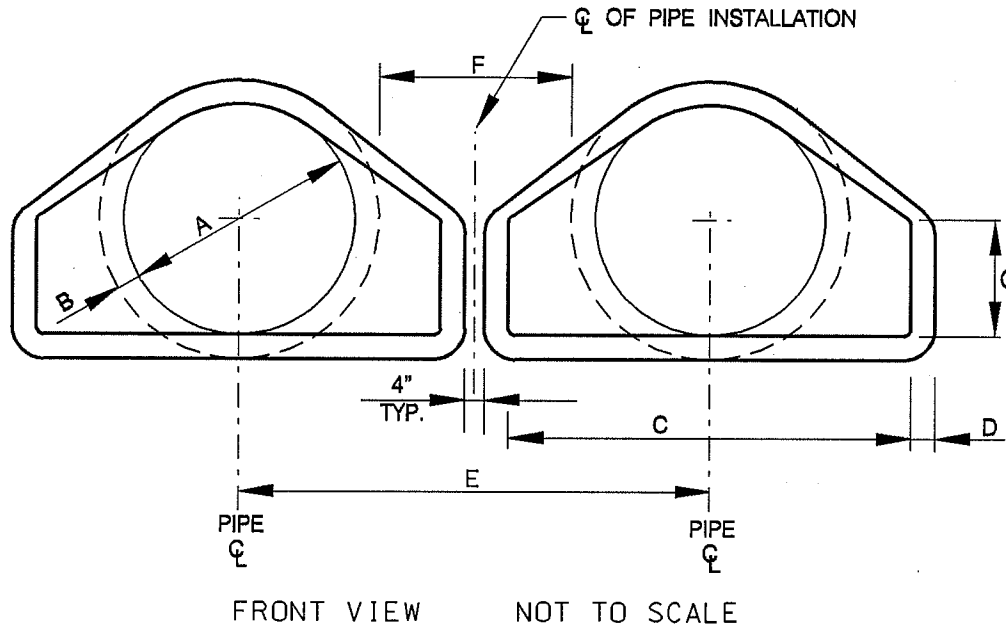

DIM.	PIPE DIAMETERS, RCP, CLASS III															
A	12"	15"	18"	21"	24"	27"	30"	36"	42"	48"	54"	60"	66"	72"	78"	84"
B	2"	2-1/4"	2-1/2"	2-3/4"	3"	3-1/4"	3-1/2"	4"	4-1/2"	5"	5-1/2"	6"	6-1/2"	7"	7-1/2"	8"
C	24"	30"	36"	42"	48"	54"	60"	72"	78"	84"	90"	96"	102"	108"	114"	120"
D	2"	2-1/4"	2-1/2"	2-3/4"	3"	3-1/4"	3-1/2"	4"	4-1/2"	5"	5"	5"	5-1/2"	6"	6-1/2"	6-1/2"
E	32"	38-1/2"	45"	51-1/2"	58"	64-1/2"	71"	84"	91"	98"	104"	110"	117"	124"	131"	137"
F	16"	19"	22"	25"	28"	31"	34"	40"	40"	40"	39"	38"	38"	38"	38"	37"
G	4"	6"	8"	9"	9-1/2"	10-1/2"	12"	15"	21"	24"	27"	30"	24"	24"	24"	36"
H	6"	6"	6"	6"	6"	6"	6"	6"	6"	6"	6"	6"	6"	6"	6"	6"
I	6"	10"	5"	6"	5-1/3"	6"	5-1/2"	8"	6"	8"	6"	7"	6"	7"	8"	9"
J	3"	3"	4"	4"	4"	6"	6"	6"	6"	8"	8"	8"	8"	8"	8"	8"
K	3"	4"	4"	6"	4"	6"	4"	5"	6"	4"	6"	6"	6"	5-1/2"	5"	4-1/2"
BLOCKS	ROW 1	2	2	3	3	4	4	5	5	6	6	7	7	8	8	8
	ROW 2	0	0	2	2	3	3	4	4	5	5	6	6	7	7	7
	ROW 3	0	0	0	0	2	2	3	3	4	4	5	5	6	6	6

NOTE: DIMENSIONS 'K' & 'H' ARE FIXED. DIMENSION 'I' IS APPROXIMATE. ACTUAL 'I' DIMENSION SHALL BE THE RESULT OF EVENLY SPACED BLOCKS WITHIN THE REMAINDER OF OPEN SPACE FOR THE ROW.

2004

CITY OF MADISON  
ENGINEERING DIVISION

MULTIPLE RCP AE

STANDARD DETAIL DRAWING 5.4.2

5.4.3

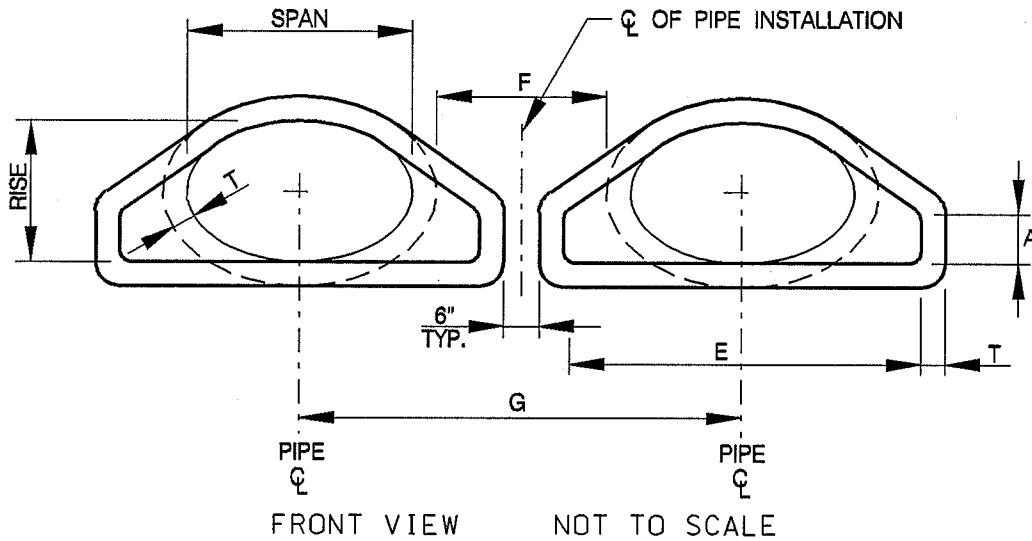

ENERGY DISSIPATERS TO BE INSTALLED ONLY WHEN DIRECTED BY THE DESIGN ENGINEER

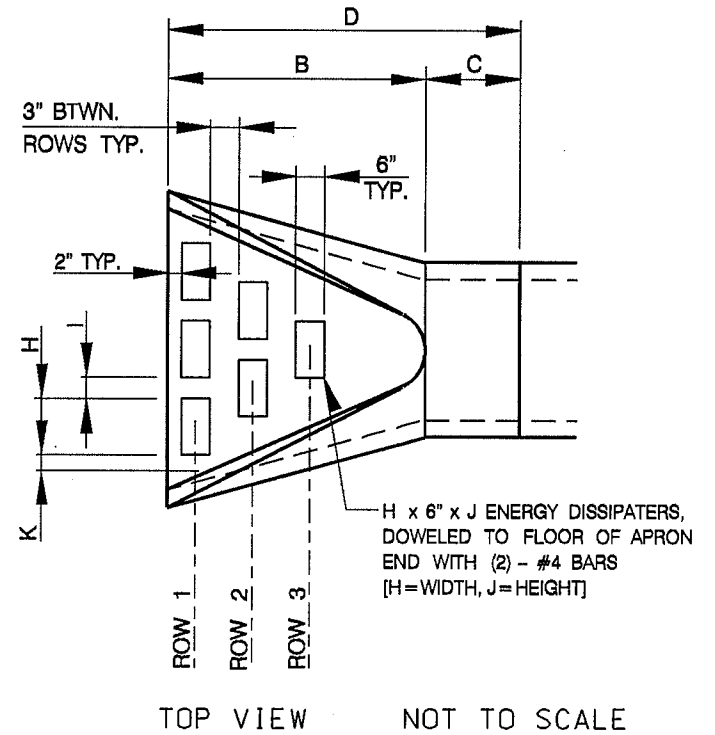

PIPE DIAMETERS, HERCP, CLASS III													QTY. OF BLOCKS			
EQUIVALENT ROUND DIA.	RISE x SPAN DIMENSIONS	A	B	C	D	E	F	G	H	I	J	K	T	ROW 1	ROW 2	ROW 3
18"	14 x 23	9.00"	3'-4"	2'-8"	6'-0"	3'-0"	1'-7"	3'-11 1/2"	6"	5"	4"	4"	2 3/4"	3	2	0
24"	19 x 30	8.50"	3'-0"	4'-0"	7'-0"	4'-0"	2'-0"	5'-0 1/2"	6"	5 1/3"	4"	4"	3 1/4"	4	3	2
30"	24 x 38	9.50"	4'-6"	2'-6"	7'-0"	5'-0"	2'-4"	6'-1 1/2"	6"	8"	4"	6"	3 3/4"	4	3	2
36"	29 x 45	11.25"	5'-0"	2'-0"	7'-0"	6'-0"	2'-9"	7'-3"	6"	8 1/2"	6"	4"	4 1/2"	5	4	3
42"	34 x 53	14.00"	5'-0"	2'-0"	7'-0"	6'-3"	2'-4"	7'-7"	6"	8 1/4"	6"	6"	5"	5	4	3
48"	38 x 60	18.00"	5'-0"	2'-0"	7'-0"	6'-10"	2'-4"	8'-3"	6"	7 1/2"	6"	4 1/4"	5 1/2"	6	5	4
54"	43 x 68	32.00"	5'-0"	3'-5"	8'-5"	7'-5"	2'-8"	9'-4"	6"	8"	6"	6 1/2"	6"	6	5	4
60"	48 x 76	36.00"	5'-0"	3'-5"	8'-5"	7'-11"	2'-1"	9'-6"	6"	9"	6"	7"	6 1/2"	6	5	4
72"	58 x 91	36.00"	5'-5"	2'-8"	8'-1"	8'-11"	1'-10"	10'-8"	6"	9 1/2"	6"	4"	7 1/2"	7	6	5

NOTE: DIMENSIONS 'K' & 'H' ARE FIXED. DIMENSION 'I' IS APPROXIMATE. ACTUAL 'I' DIMENSION SHALL BE THE RESULT OF EVENLY SPACED BLOCKS WITHIN THE REMAINDER OF OPEN SPACE FOR THE ROW.

2003

CITY OF MADISON ENGINEERING DIVISION
<b>MULTIPLE HERCP AE</b>
STANDARD DETAIL DRAWING 5.4.3

5.4.4

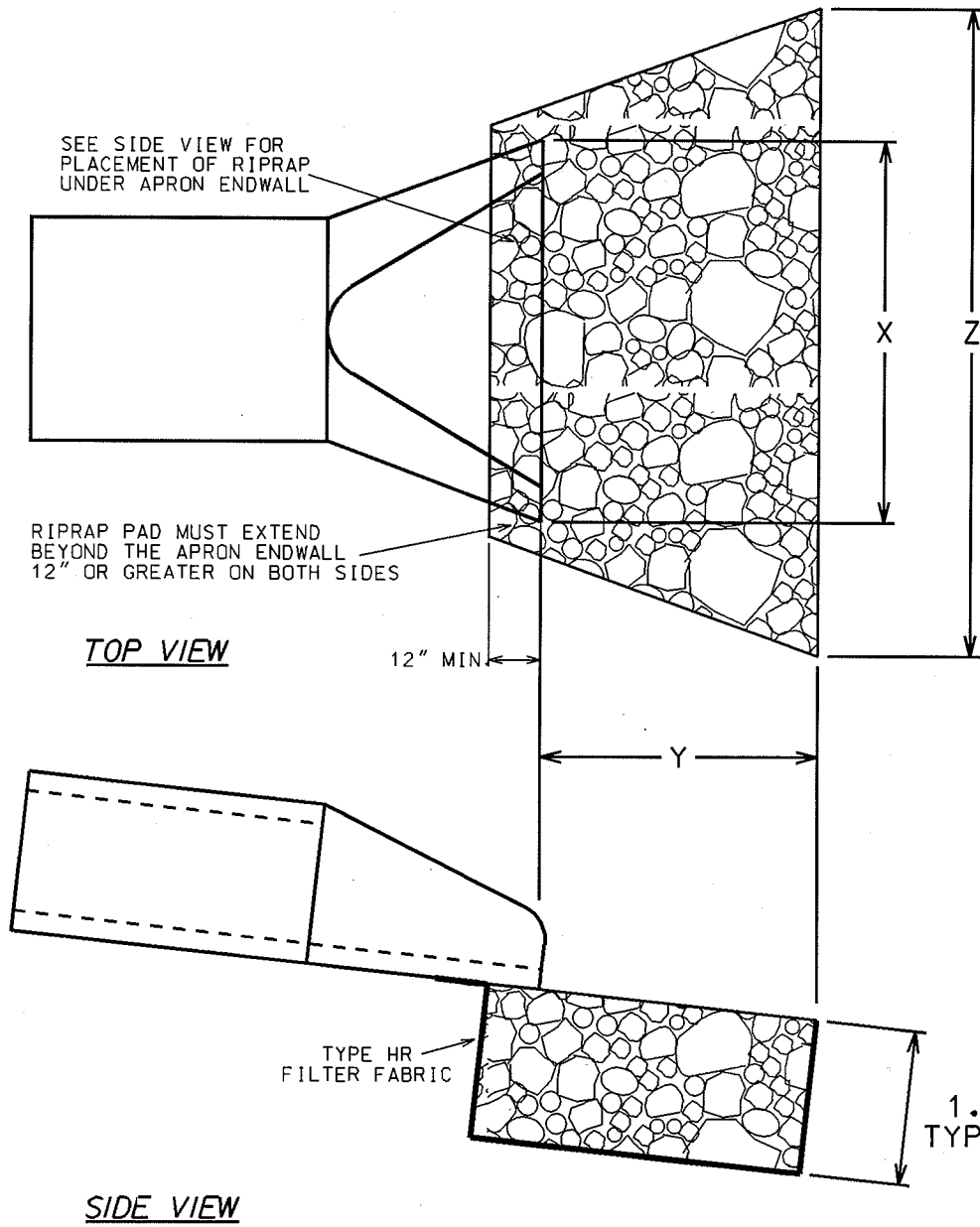

DIA (in)	X (in)	Y (in)	Z (in)	APPROX. WEIGHT (tons)
12	24	48	48	1.78
15	30	60	60	2.64
18	36	60	60	2.78
21	42	72	72	3.83
24	48	72	72	4.00
27	54	72	81	4.42
30	60	84	90	5.64
36	72	96	108	7.56
42	78	96	120	8.22
48	84	108	120	9.50
54	90	108	150	11.00
60	96	108	162	11.75
66	102	132	174	15.28
72	108	132	186	16.19

NOTES:

- 1) CITY OF MADISON STANDARD SPECIFICATIONS SHALL APPLY TO ALL INSTALLATIONS.
- 2) PIPES 36" AND GREATER SHALL HAVE JOINT TIES PER STANDARD DETAIL DRAWING 5.4.6 & SECTION 504.2 (1).
- 3) PIPES 36" OR GREATER SHALL HAVE 50% OF THE RIPRAP PAD PLACED WITH A SLURRY GROUT MIX ON AN UNEVEN RIPRAP SURFACE. SLURRY GROUT SHALL BE TYPE B SLURRY PER SECTION 300 OF THE STANDARD SPECIFICATIONS.
- 4) TWIN APRON INSTALLATIONS SHALL BE GOVERNED BY THE OUTSIDE DIMENSIONS OF A SINGLE PIPE.

2004

CITY OF MADISON  
ENGINEERING DIVISION

RIPRAP AT  
APRON END WALLS

STANDARD DETAIL DRAWING 5.4.4

NOT TO SCALE

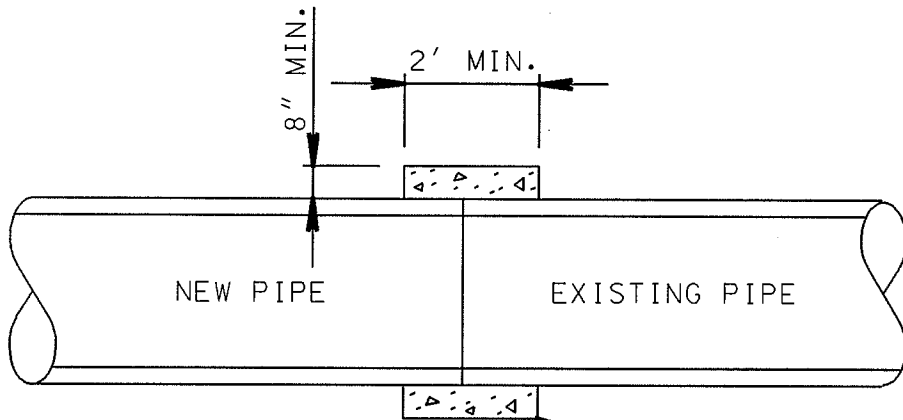

SECTION A-A

FIELD Poured CONCRETE COLLAR  
WHERE REQUIRED TO SEAL PIPE

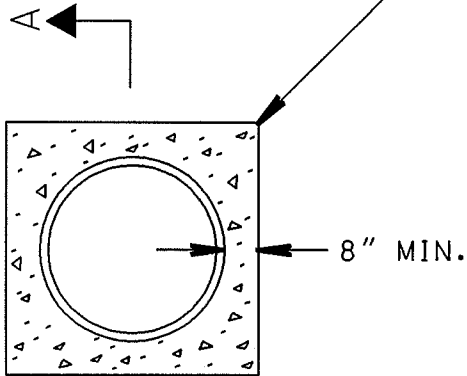

NOTE:

IF REQUESTED BY THE CONSTRUCTION  
ENGINEER, FIBER REINFORCED  
CONCRETE SHALL BE PROVIDED

5.4.5

2004

CITY OF MADISON  
ENGINEERING DIVISION

CONCRETE COLLAR

STANDARD DETAIL DRAWING 5.4.5

**ALTERNATE 1**  
**EYE BOLT AND TIE ROD ASSEMBLY**  
 (JOINT TIES FOR 72" DIA AND OVER CONCRETE PIPE)

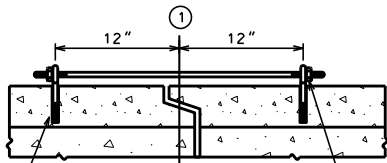
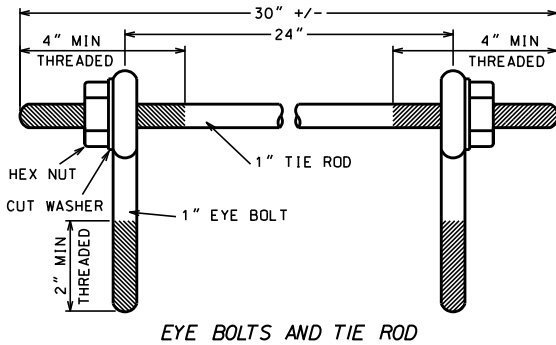

② INSERT. CAST-IN-PLACE DURING FABRICATION FOR 1" DIA. EYE BOLT

WELDED EYE BOLT OR APPROVED EQUAL

ROTATE 90° FOR NORMAL POSITION

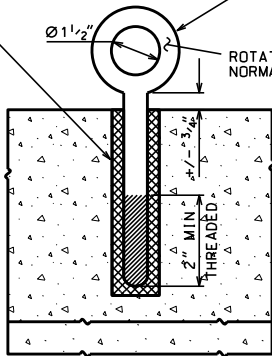

(CAST-IN-PLACE THREADED INSERT) LONGITUDINAL SECTIONS

**ALTERNATE 2**  
**EYE BOLT AND TIE ROD ASSEMBLY**  
 (JOINT TIES FOR 18" TO 66" DIA CONCRETE PIPE)

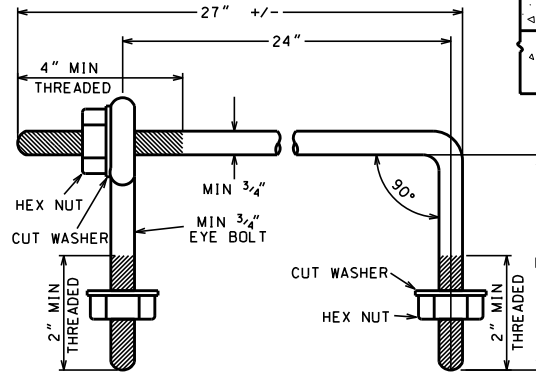

NOTE: TWO EYE BOLTS MAY BE USED WITH A 30" LONG THREADED ROD IN LIEU OF THE 90° BENT TIE ROD

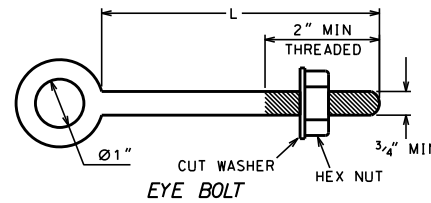
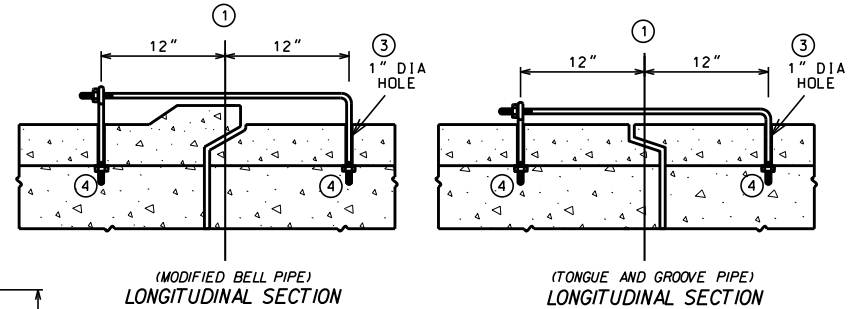

PIPE SIZE	L = LENGTH	
	TONGUE & GROOVE PIPE	MODIFIED BELL PIPE
18" TO 24"	4 1/2"	6 1/4"
30"	5"	7"
36"	5 1/2"	7"
42"	6"	
48"	6 1/2"	
60"	7 1/2"	
66"	8"	

EYE BOLT DIMENSION TABLE

**ALTERNATE 3**  
**ADJUSTABLE TIE ROD**  
 (JOINT TIES FOR 12" TO 108" DIA CONCRETE PIPE)

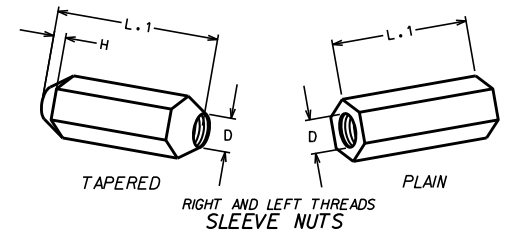
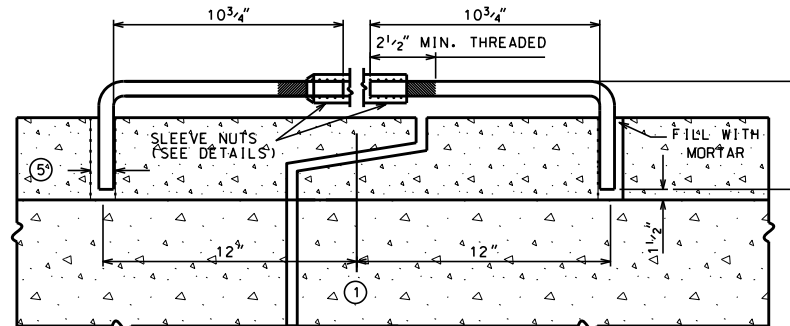

PIPE DIAMETER	TIE ROD DIAMETER	D	L	H	R
12" TO 30"	1 1/2"	1 1/2"	5"	1 1/2"	1 3/4"
66" TO 84"	3/4"	3/4"	5"	1 1/2"	5"
90" TO 104"	1"	1"	7"	1 1/16"	7 1/2"

ADJUSTABLE TIE ROD TABLE

PLACEMENT OF (2) CAST-IN-PLACE INSERTS OR HOLES DURING FABRICATION FOR PIPE SECTIONS REQUIRING TIE RODS

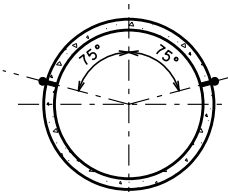

TRANSVERSE SECTION

GENERAL NOTES:

CONCRETE CULVERT PIPE SHALL BE TIED TOGETHER IN THE MANNER ILLUSTRATED BY THIS DETAIL AND PER STANDARD SPEC. 504.3 (C) AT LOCATION DESIGNATED ON THE PLAN. THE CONTRACTOR MAY USE EITHER ALTERNATE 1, 2, OR 3 FOR DRAINAGE STRUCTURES. ONLY ALTERNATE 1 AND 3 MAY BE USED FOR CATTLE PASSES. UNLESS OTHERWISE STATED IN THE CONTRACT, THE MATERIALS, FABRICATION AND WORK NECESSARY TO THE CULVERT PIPE AS INDICATED ON THE PLANS AND BY THIS DETAIL WILL BE CONSIDERED INCIDENTAL TO CULVERT PIPE, REINFORCED CONCRETE CULVERT PIPE, OR REINFORCED CONCRETE PIPE CATTLE PASS.

DETAILED DRAWINGS FOR PROPOSED ALTERNATE DESIGNS FOR JOINT TIES SHALL BE SUBMITTED TO THE ENGINEER FOR APPROVAL.

- ① C. OF TONGUE AND GROOVE OR BELL AND SPIGOT JOINTS
- ② THE INSIDE OF THE THREADED INSERTS SHALL BE CLEAN TO ALLOW THE INSERTION OF THREADED EYE BOLTS
- ③ HOLES SHALL BE CAST-IN-PLACE OR DRILLED, 12" FROM C. OF TONGUE AND GROOVE
- ④ RODS SHALL BE CUT FLUSH W/ BOLT HEAD OR THE TIE SYSTEM ROTATED SO THE NUT IS ON THE OUTSIDE OF THE PIPE
- ⑤ ROD DIAMETER = 1 INCH

CITY OF MADISON  
 ENGINEERING DIVISION

**CONCRETE PIPE  
 JOINT TIES**

STANDARD DETAIL DRAWING 5.4.6

5.4.7

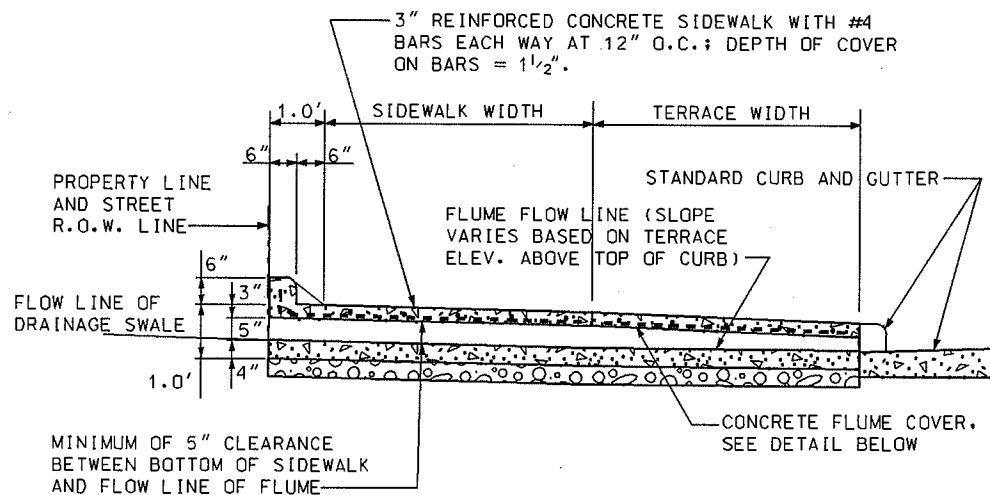

**DRAINAGE FLUME  
LONGITUDINAL SECTION**

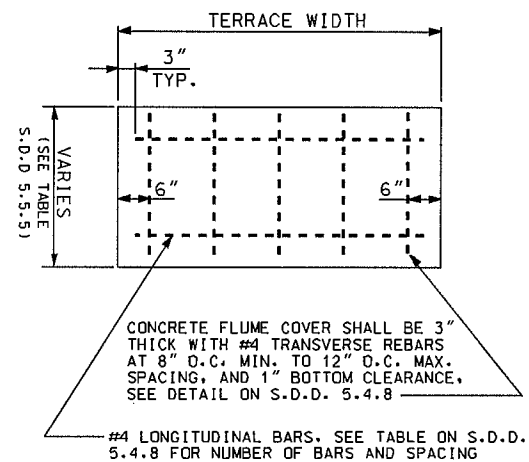

**TERRACE CONCRETE FLUME COVER  
PLAN VIEW**

**NOTES:**

1. A MINIMUM OF 2 SIDEWALK SECTIONS SHALL BE REMOVED AND REPLACED, UNLESS OTHERWISE DIRECTED BY THE CITY ENGINEER.
2. ALTERNATE ALIGNMENTS OF TERRACE PORTION OF FLUME SHALL BE ALLOWED WITH THE PRIOR APPROVAL OF THE CITY ENGINEER.
3. ALL REINFORCING BARS SHALL BE EPOXY COATED.
4. SIDEWALK AND SIDEWALK CURBING TO BE POURED MONOLITHIC.

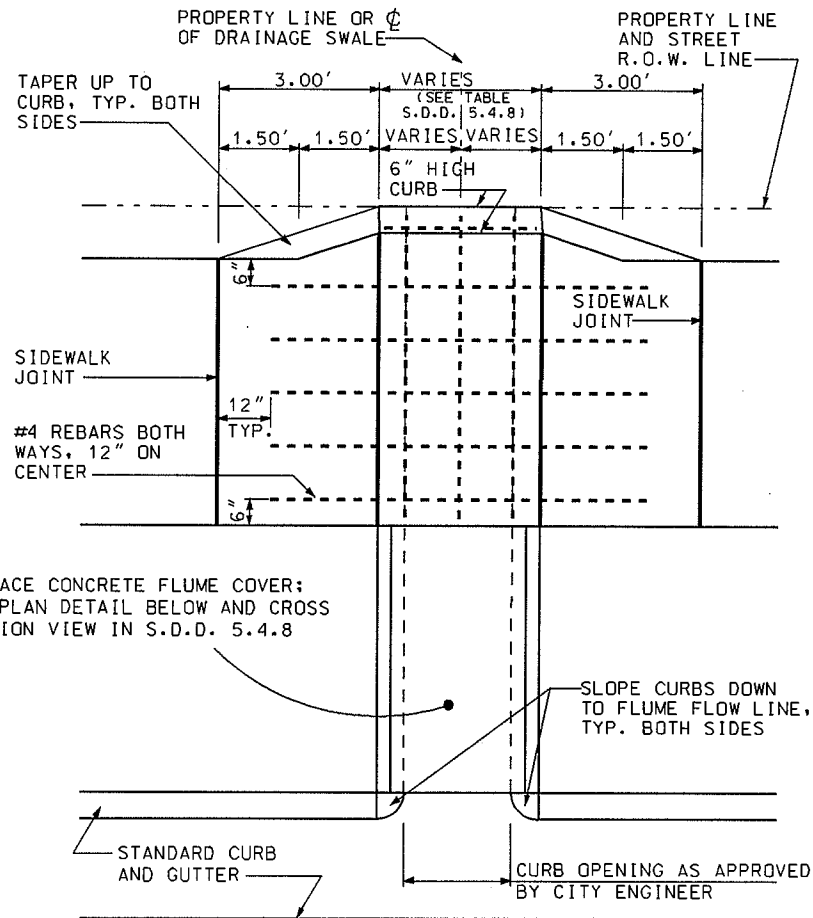

**DRAINAGE FLUME  
PLAN VIEW**

2004

CITY OF MADISON  
ENGINEERING DIVISION

**DRAINAGE FLUME  
DETAIL**

PLATE 1 OF 2

STANDARD DETAIL DRAWING 5.4.7

5.4.8

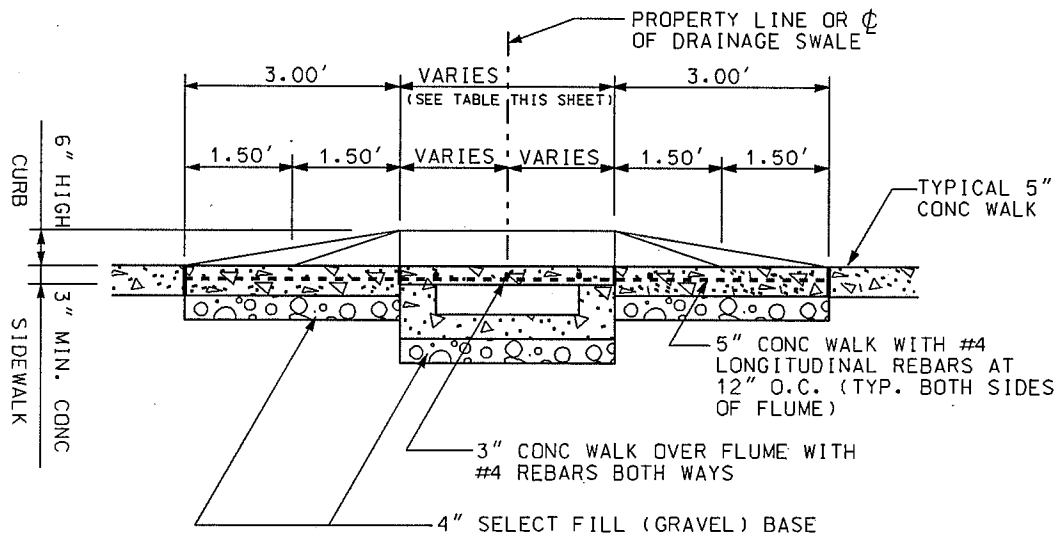

**DRAINAGE FLUME AT SIDEWALK  
CROSS SECTION**

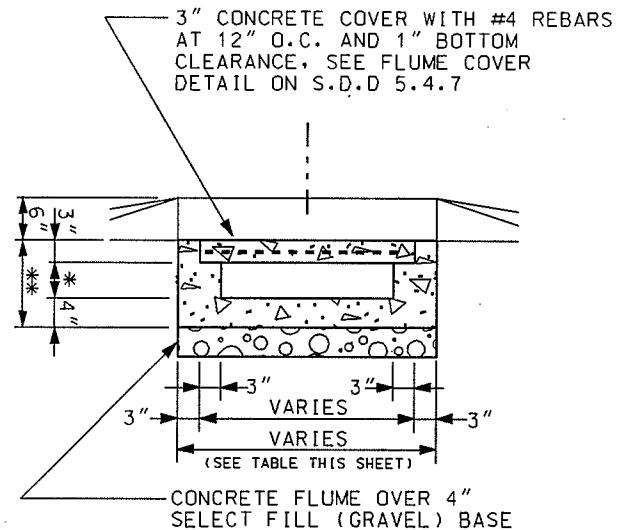

- \* DIMENSION VARIES, 5" AT SIDEWALK TO 3" AT CURB.
- \*\* DIMENSION VARIES, 12" AT SIDEWALK TO 10" AT CURB.

**DRAINAGE FLUME AT TERRACE  
CROSS SECTION**

**ON GRADE IMPERVIOUS AREA IN SQUARE FEET**

OUTLET FLUME SIZE	COVER WIDTH	NO. OF LONG. REBARS	CLEAR FROM EDGE	CENTER SPACING	EQUIV. PIPE DIAM.	GRADE PER FOOT OF PIPE & FLUME			
						1/16"	1/8"	1/4"	1/2"
12"x3"	18"	2	3"	12"	4"	1,625	7,470	3,740	4,720
18"x3"	24"	2	6"	12"	6"	5,200	7,470	10,400	14,600
24"x3"	30"	3	3"	12"	8"	11,650	16,250	22,750	32,600
30"x3"	36"	3	6"	12"	10"	22,100	30,850	44,250	63,000
36"x3"	42"	4	3"	12"	12"	34,150	52,300	71,500	102,200

NOTE: INCREASE ROOF AREAS BY 25% PRIOR TO USING CHART

2004

CITY OF MADISON  
ENGINEERING DIVISION

**DRAINAGE FLUME  
DETAIL**

PLATE 2 OF 2

STANDARD DETAIL DRAWING 5.4.8

5.4.9

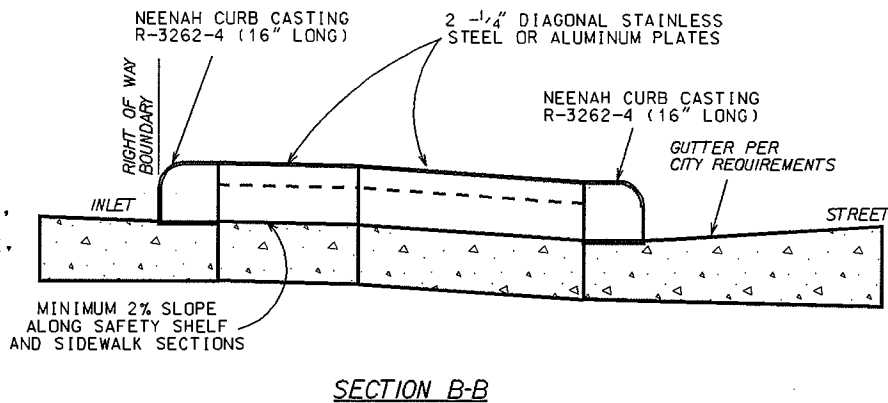
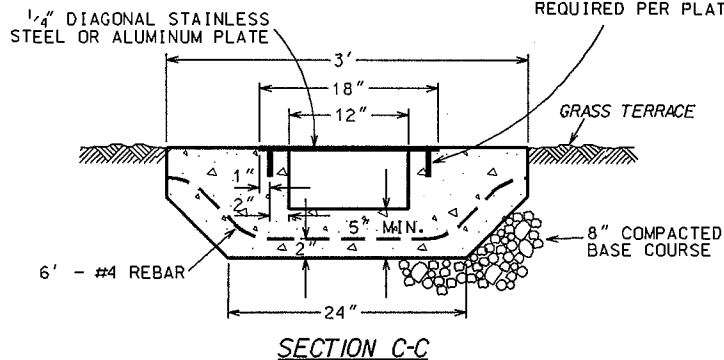
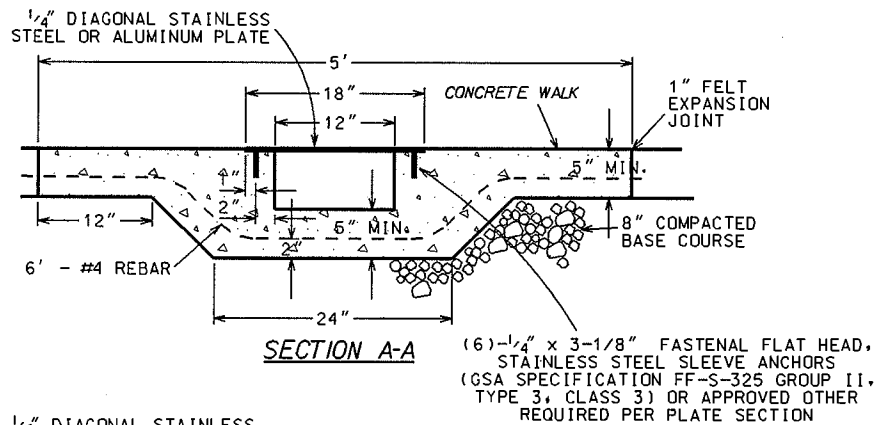
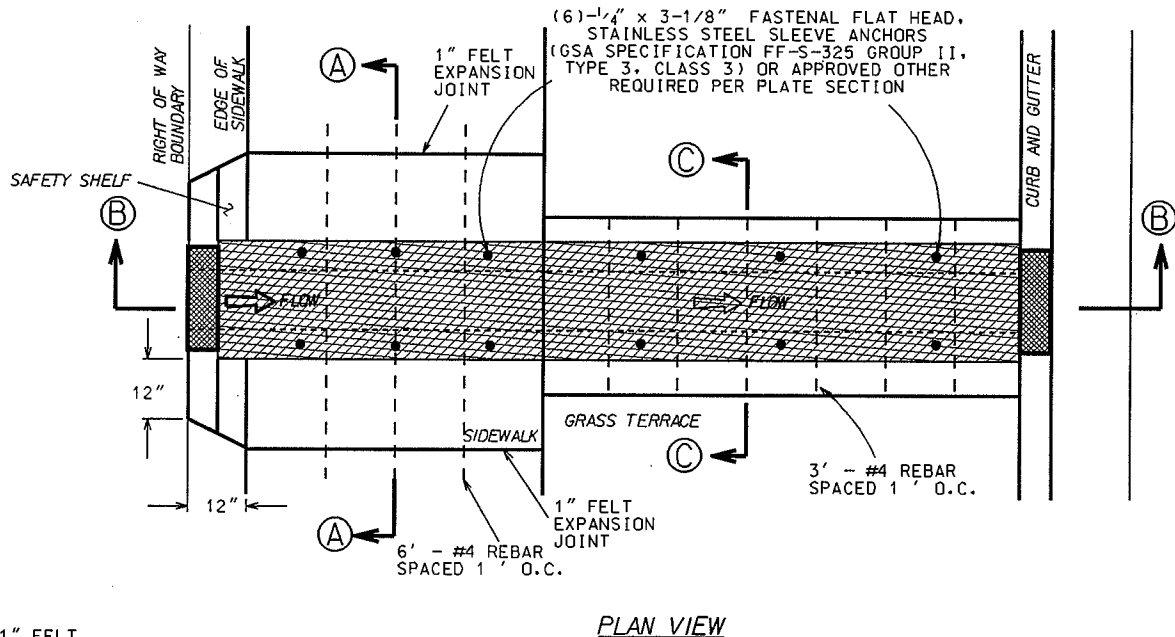
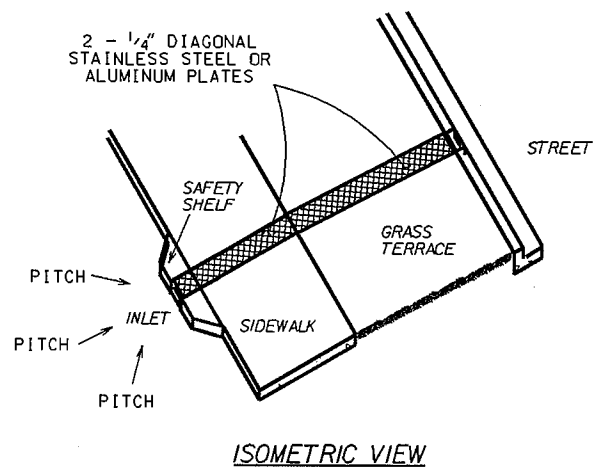

NOTES:

- 1) WHEN THE SIDEWALK IS ABUTTING A GRASSED PROPERTY, THE CONCRETE FLAG AND NEENAH CASTING ON THE PROPERTY SIDE SHALL BE OMITTED. ONLY ONE NEENAH CURB CASTING IS REQUIRED FOR THE STREET OUTLET.
- 2) WHEN THE SIDEWALK IS ABUTTING A PAVED PROPERTY, THE CONCRETE FLAG SHALL EXTEND 1' BEYOND THE RIGHT OF WAY BOUNDARY.

2004

CITY OF MADISON ENGINEERING DIVISION
<b>SIDEWALK FLUME</b>
STANDARD DETAIL DRAWING 5.4.9



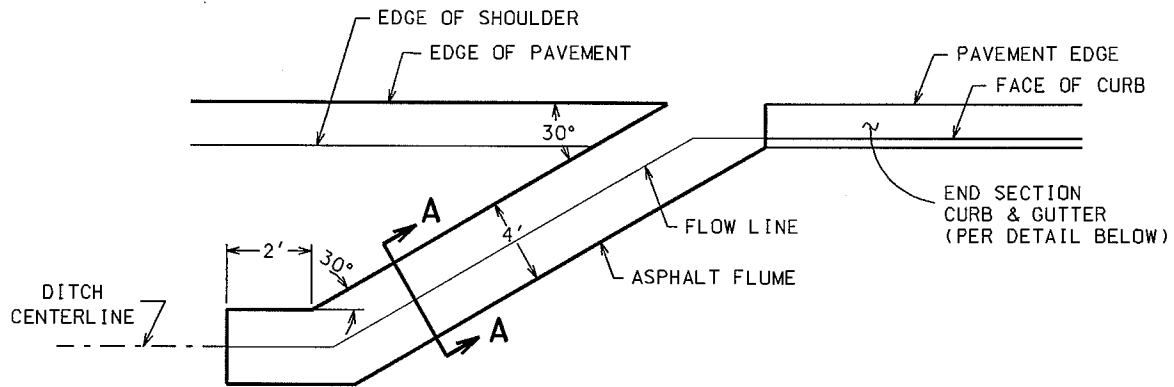

ASPHALT FLUME DETAIL  
TOP VIEW

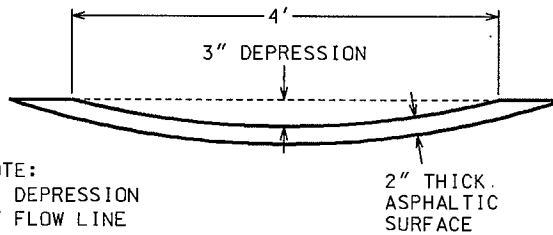

ASPHALT FLUME  
SECTION A-A

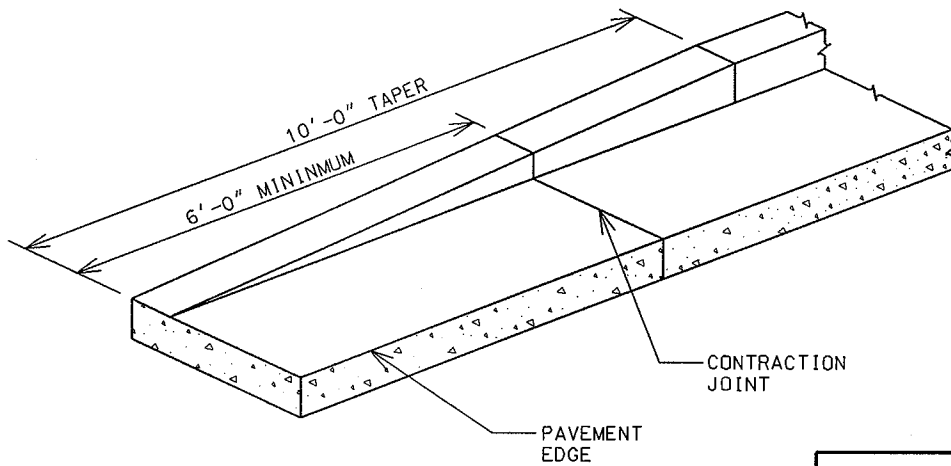

END SECTION CURB AND GUTTER

2004

CITY OF MADISON ENGINEERING DIVISION
<b>CURB TO DITCH TRANSITION ASPHALT FLUME</b>
STANDARD DETAIL DRAWING 5.4.10



5.4.12

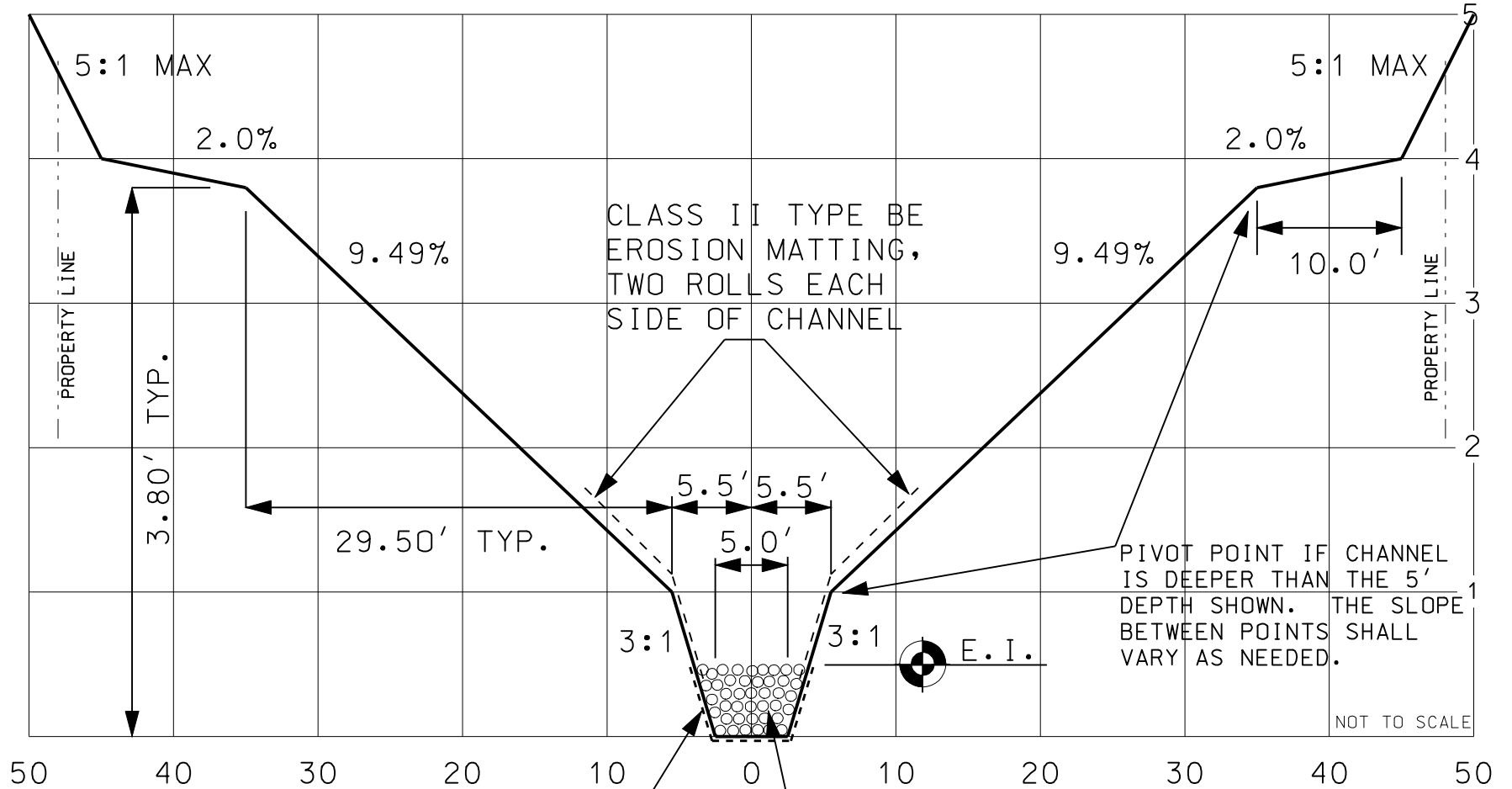

'R' FABRIC TO MEET D.O.T. SPECIFICATIONS

CLEAR STONE, 3"-5" SMALLEST DIMENSION LARGEST DIMENSION SHALL NOT EXCEED 3x IT'S SMALLEST DIMENSION

NOTE: LONGITUDINAL SLOPE ALONG CHANNEL VARIES AS PER PLANS.

2005

CITY OF MADISON  
ENGINEERING DIVISION

TYPICAL  
GREENWAY SECTION  
(STABILIZED FLOWLINE)

STANDARD DETAIL DRAWING 5.4.12

# BIO-RETENTION TYPICAL DETAIL

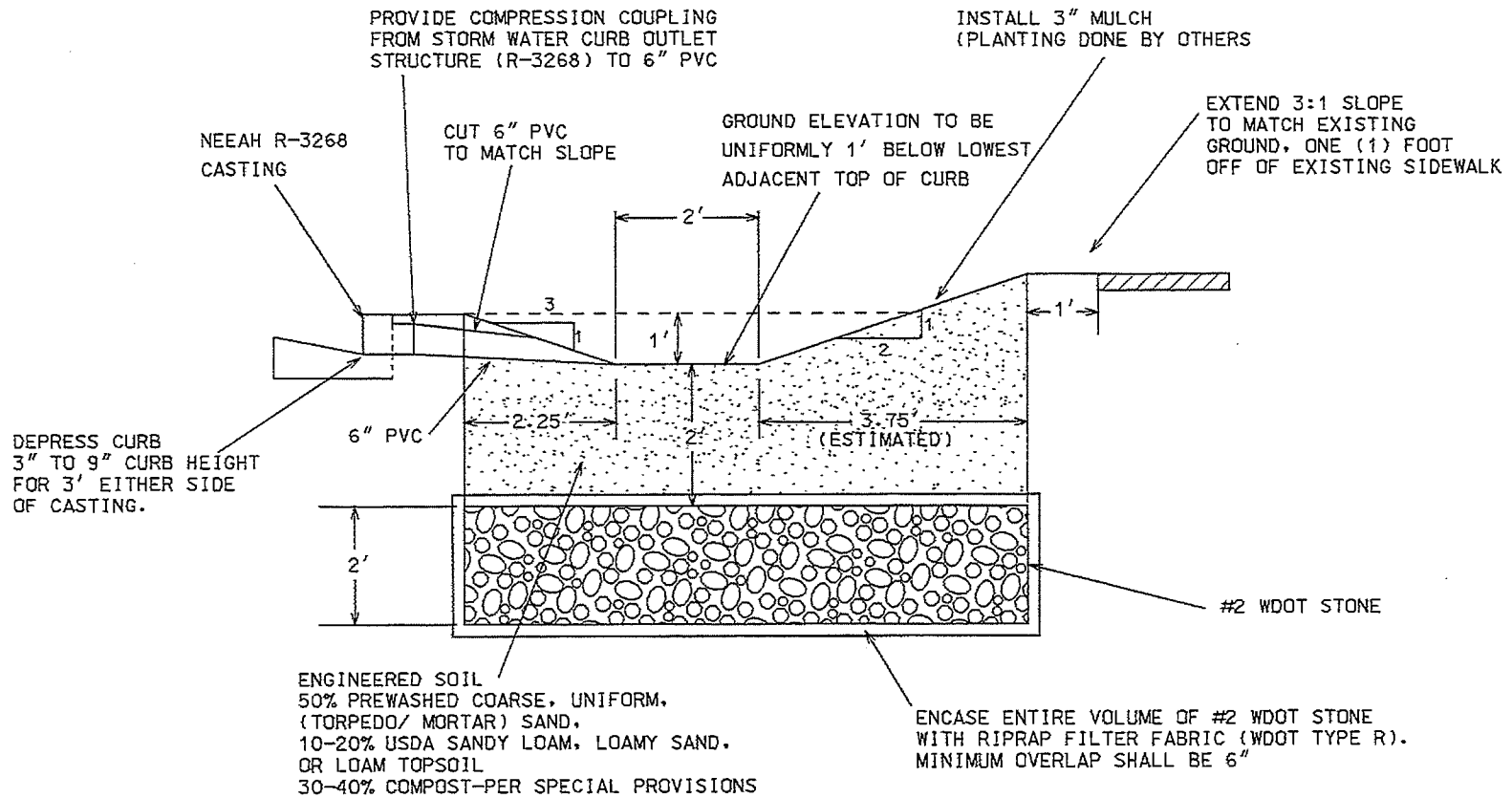

5.4.13

NOT TO SCALE

2011

CITY OF MADISON ENGINEERING DIVISION
BIO-RETENTION DETAIL
STANDARD DETAIL DRAWING 5.4.13

NOTE: ALL BARS TO BE EPOXY COATED.

SPLASH PAD  
8" THICK: #4 BARS SPACED  
EVENLY AT APPROXIMATELY  
24" CENTERS BOTH WAYS. 3"  
CLEAR FROM BOTTOM OF PAD.

HEADER  
SEE REINFORCEMENT DETAIL  
FOR DIMENSIONS AND INSET  
FOR ORIENTATION: 1/2" FELTS  
TO BE PLACED EACH JOINT AND  
AT CONNECTION TO WINGWALLS

**FILL NOTES:**

- (1) WINGWALLS WITH SPLASH  
PAD DOWNSTREAM:  
SEE S.O.D. 5.5.2 FOR  
INSTALLATION OF RIPRAP  
AT BOX CULVERT WINGWALLS.
- (2) WINGWALLS WITH SPLASH  
PAD UPSTREAM:  
FILL AREA WITH NON-GRANULAR  
GENERAL FILL OVERLAID WITH  
EROSION MATTING.

#6 BARS  
SPACED EVENLY  
(APPROX. 6" O.C.)

#4 BARS SPACED  
6" O.C. NUMBER  
OF BARS VARY AS  
WALL HEIGHT VARIES  
ALONG LENGTH

#6 BARS  
SPACED EVENLY  
(APPROX. 6" O.C.)

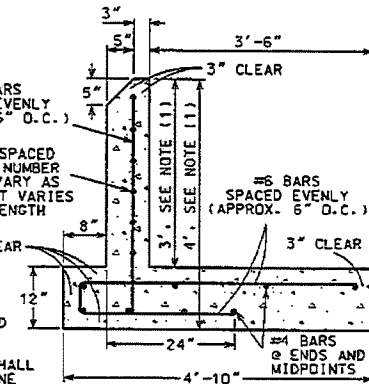

**BEDDING NOTES:**

- (1) ALL FOOTINGS SHALL HAVE  
12" OF 3" CLEAR STONE PLACED  
AS BEDDING.
- (2) AREA BELOW SPLASH PAD SHALL  
BE FILLED WITH 3" CLEAR STONE

NOTE:  
(1) VERTICAL DIMENSION SHOWN IS  
AT END OF WALL. DIMENSION INCREASES  
ALONG WALL LENGTH. SEE SIDE VIEW.  
(2) THE WINGWALL SHALL BE ONE  
CONTINUOUS POUR FROM CONSTRUCTION  
JOINT ABOVE FOOTING TO TOP OF WALL.

**SECTION A-A**

WINGWALL DETAIL AT END OF WALL

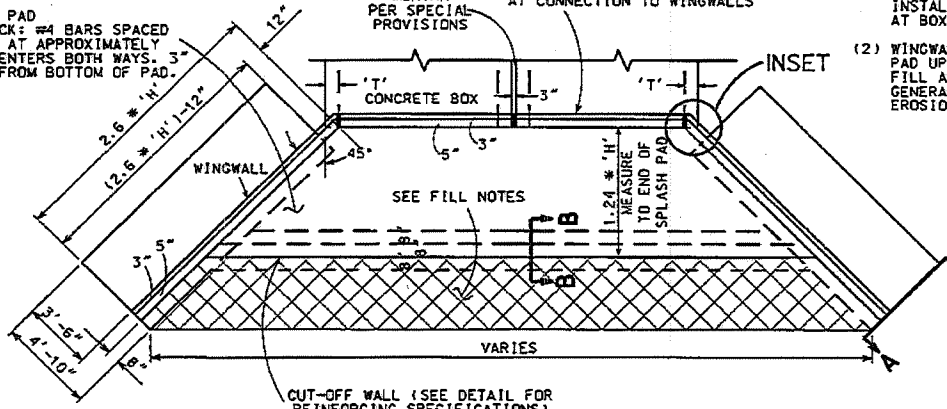

**TOP VIEW**

WINGWALLS WITH SPLASHPAD

FOR UPSTREAM BOX CULVERTS,  
THE ENTRANCE SHALL HAVE 45°  
CHAMFERED ROOF AND SIDE EDGES.

MITER ALL EXPOSED  
POURED WALLS 45°

WINGWALLS SHALL BE ONE  
CONTINUOUS POUR FROM  
CONSTRUCTION JOINT ABOVE  
FOOTING TO TOP OF WALL—  
NO CONSTRUCTION JOINT  
AT SPLASH PAD

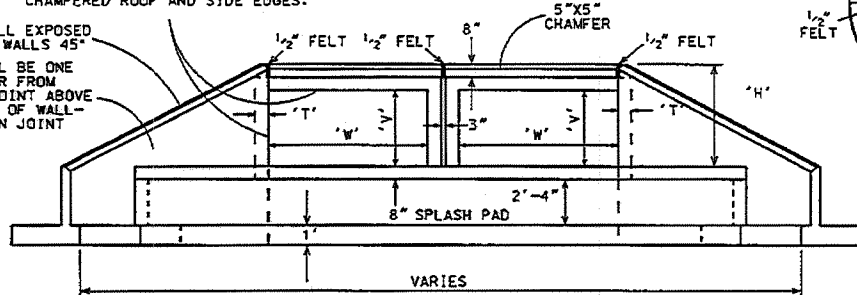

**FRONT VIEW**

WINGWALLS WITH SPLASHPAD

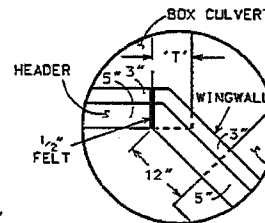

**INSET**

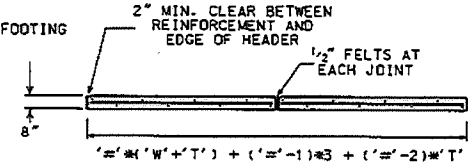

VERTICAL REINFORCEMENT PER SECTION STAGGERED  
#4 BARS SPACED EVENLY ON APPROXIMATELY 1'-3" CENTERS.  
2" CLEAR EACH SIDE; BARS TO BE EMBEDDED IN CONCRETE 4".  
HORIZONTAL REINFORCEMENT PER SECTION:  
(1' W + 2 \* 7' 4") OF #4 BAR CENTERED BOTH DIRECTION  
IN PROPOSED BOX CULVERT HEADER.

**TOP VIEW**

BOX CULVERT HEADER REINFORCEMENT DETAIL

**STEEL CONNECTION NOTES:**

- (1) CONNECTION OF SPLASH PAD TO BOX CULVERTS:  
12" LONG #6 REBARS SPACED EVENLY ON APPROXIMATELY 2'-6" CENTERS.  
TIGHT DRIVEN 6" INTO END OF BOX CULVERT FLOOR AND EMBEDDED 6" INTO  
SPLASH PAD FLOOR WITH 2" CLEAR SPACING EACH SIDE.
- (2) CONNECTION OF WINGWALL TO BOX CULVERT:  
#4 REBARS FIELD BENT WITH 'L' DIMENSIONS OF 6"x6" SPACED EVENLY  
ON APPROXIMATELY 8" CENTERS. ONE 6" LEG DRIVEN INTO SIDE OF  
BOX AND THE OTHER EMBEDDED 6" INTO THE WINGWALL. BARS SHALL  
HAVE 2" CLEAR SPACING TOP AND BOTTOM. (SAME EACH WINGWALL)
- (3) CONNECTION OF SPLASH PAD TO WINGWALLS:  
#4 REBARS FIELD BENT WITH 'L' DIMENSIONS OF 12"x8"  
SPACED EVENLY ON APPROXIMATELY 12" CENTERS. THE  
12" LEG EMBEDDED INTO THE SPLASH PAD AND THE 8" LEG  
EMBEDDED DOWNWARD INTO THE WINGWALL. BARS SHALL BE  
CENTERED IN THE SPLASH PAD AND THE WINGWALL. WINGWALLS  
SHALL BE ONE CONTINUOUS POUR FROM CONSTRUCTION JOINT  
ABOVE FOOTING TO TOP OF THE WALL. THERE SHOULD BE NO  
CONSTRUCTION JOINT AT PAD ELEVATION.
- (4) CONNECTION OF SPLASH PAD TO THE CUT-OFF WALL:  
(SEE CUT-OFF WALL DETAIL) THE #4 BAR REINFORCING OF  
THE CUT-OFF WALL SHALL BE FIELD BENT INTO A 'C' AND  
SHAPES WITH THE DIMENSIONS 3'-4"x8"x6" SPACED EVENLY  
ON APPROXIMATELY 24" CENTERS. THE 8" LEG ALTERNATES  
INTO FOOTING LEG AND 6" EMBEDDED INTO SPLASH PAD. THE  
BARS SHALL BE CENTERED IN THE CUT-OFF WALL.

**VARIABLES (UNITS: INCHES)**

'N' = NUMBER OF BOXES  
'H' = INSIDE BOX HEIGHT +  
ROOF THICKNESS +  
HEADER HEIGHT  
'W' = INSIDE WIDTH OF BOX  
'V' = INSIDE HEIGHT OF BOX  
'T' = SIDE WALL THICKNESS

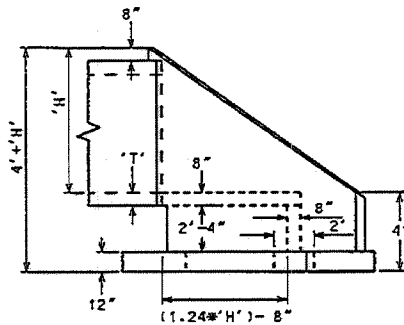

**SIDE VIEW**

WINGWALLS WITH SPLASHPAD

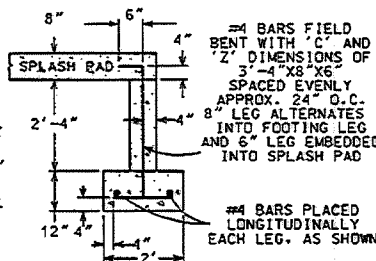

**SECTION B-B**

CUT-OFF WALL DETAIL

DRAWING NOT TO SCALE

2010

CITY OF MADISON  
ENGINEERING DIVISION

BOX CULVERT  
WINGWALL

STANDARD DETAIL DRAWING 5.5.1

5.5.1

5.5.2

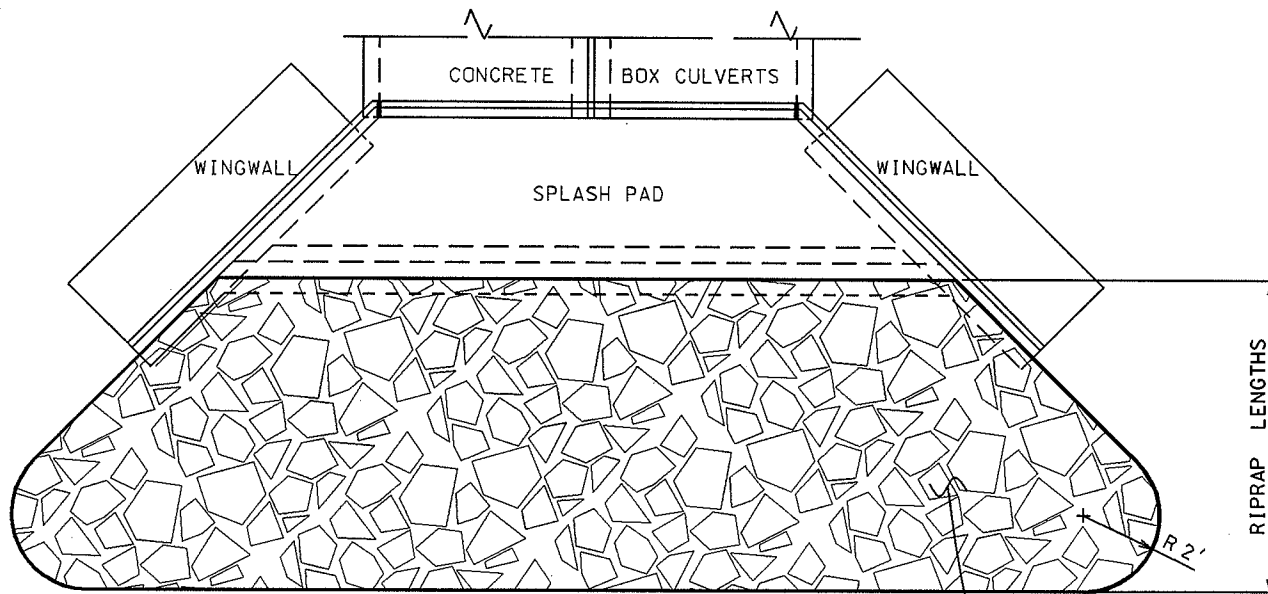

CONSTRUCT WINGWALLS AND SPLASH PAD PER S.D.D. 5.5.1

TOP VIEW  
WINGWALLS WITH SPLASHPAD

RIPRAP LENGTHS	
BOX WIDTH FT	RIPRAP LENGTH FT
4	10
6	12
8	15
10	20
10+	20

FILL AREA WITH COMPACTED NON-GRANULAR FILL, INSTALL 2' HEAVY RIPRAP OVER TYPE HR FILTER FABRIC

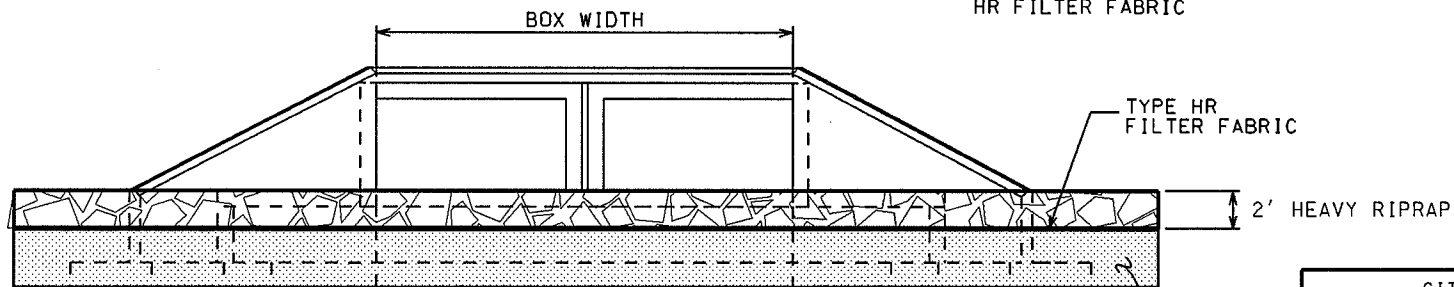

FRONT VIEW  
WINGWALLS WITH SPLASHPAD

2004

CITY OF MADISON  
ENGINEERING DIVISION

RIPRAP AT BOX  
CULVERT WINGWALLS

STANDARD DETAIL DRAWING 5.5.2

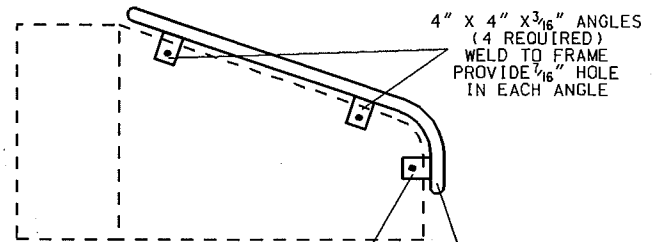
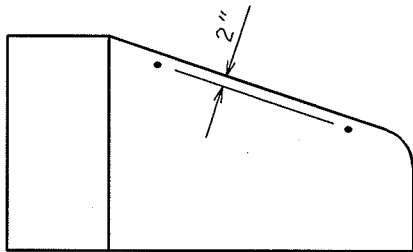
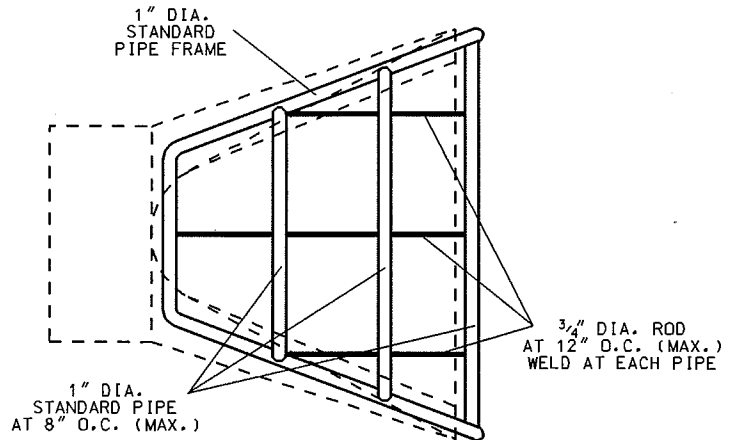
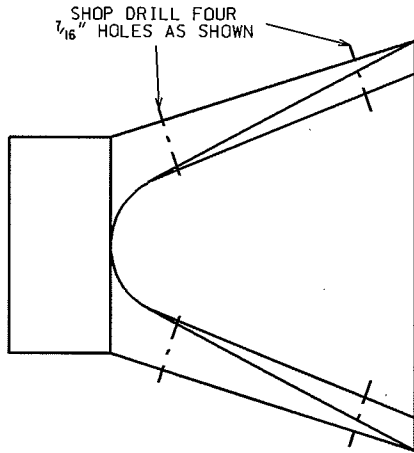

PROVIDE 2 ADDITIONAL  
CONNECTIONS WHEN  
PIPE IS 36" OR LARGER

1" DIA.  
STANDARD  
STEEL PIPE

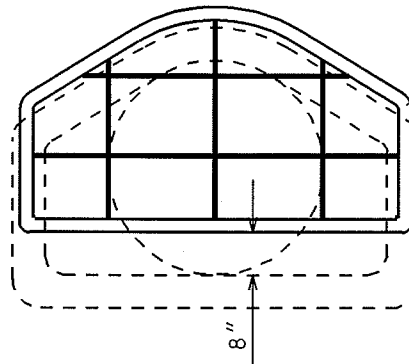
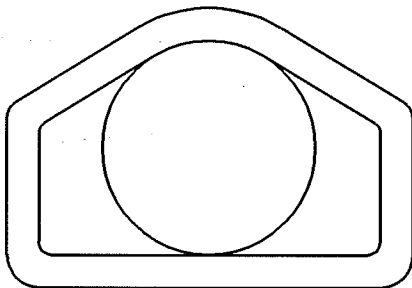

THE CONTRACTOR SHALL BOLT THE PIPE GATE  
TO THE CONCRETE ENDWALL WITH FOUR  $\frac{3}{8}$ " X 6"  
MACHINE BOLTS WITH NUTS ON INSIDE WALL.

**PAINING SPECIFICATIONS**

FOR PAINTING REQUIREMENTS, SEE SECTION 506.2 (b)  
STRUCTURAL STEEL PAINT-EPOXY  
SYSTEM FOR STORM SEWER GRATES/GATES

2004

CITY OF MADISON  
ENGINEERING DIVISION

RCP AE  
GATE

STANDARD DETAIL DRAWING 5.6.1

**FRONT ELEVATION**

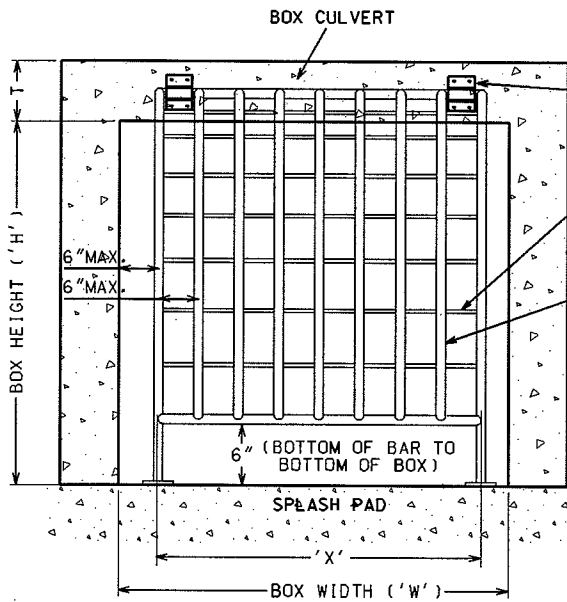

HINGE SHALL BE MOUNTED CENTERED IN BOX ROOF. SEE HINGE DETAIL FOR CONSTRUCTION AND TABLE FOR QUANTITIES.

HORIZONTAL MEMBERS:  
3/4" DIA. ROD PER CHART

VERTICAL MEMBERS:  
1 1/2" DIA. STANDARD STEEL PIPE (SCHEDULE 40)

EXTEND FRAMING MEMBER TO CREATE FRONT SUPPORTS AS SHOWN BELOW

**SIDE VIEW**

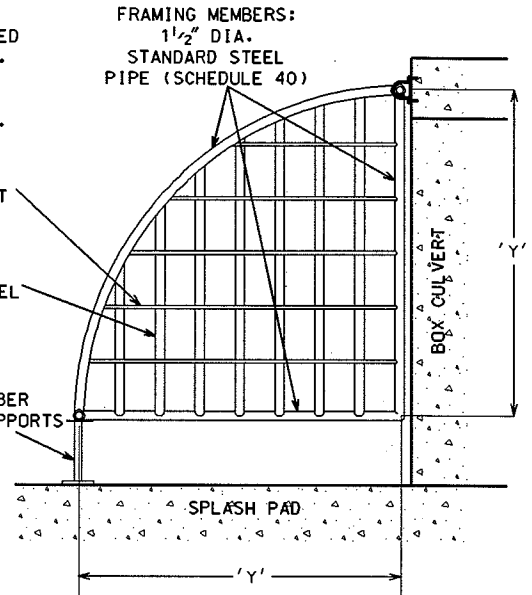

**TWO PIECE SPLIT HINGE DETAIL**

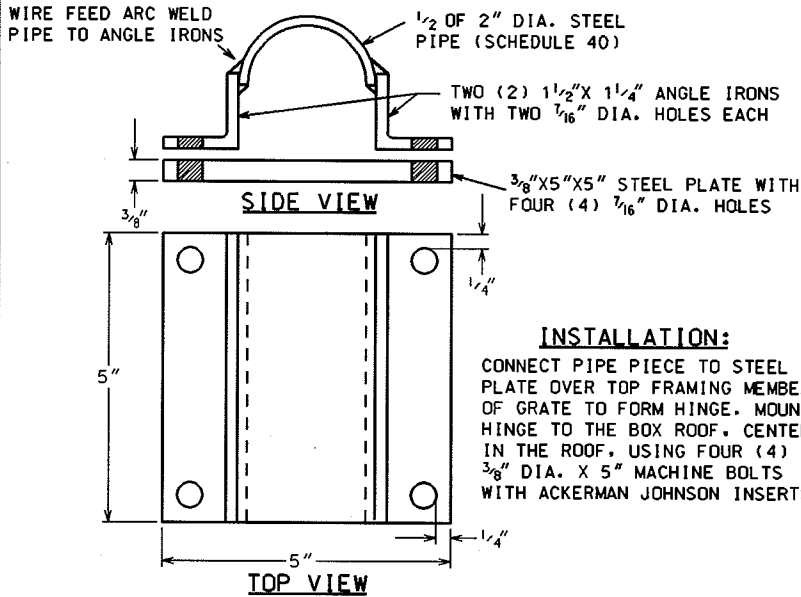

**INSTALLATION:**

CONNECT PIPE PIECE TO STEEL PLATE OVER TOP FRAMING MEMBER OF GRATE TO FORM HINGE. MOUNT HINGE TO THE BOX ROOF, CENTERED IN THE ROOF, USING FOUR (4) 3/8" DIA. X 5" MACHINE BOLTS WITH ACKERMAN JOHNSON INSERTS

**ISOMETRIC VIEW**

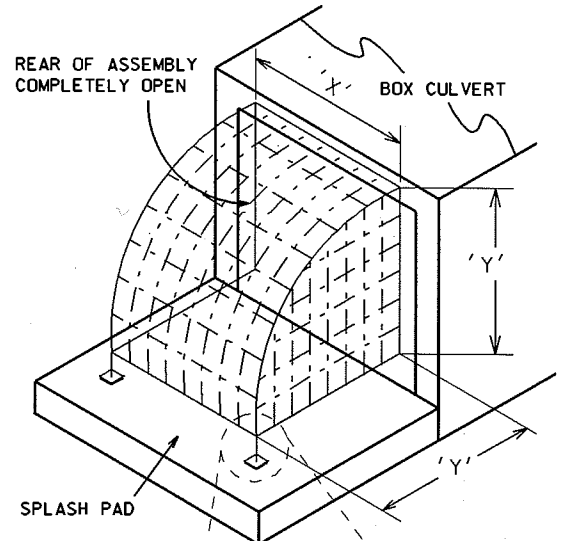

4"X4"X1/2" STEEL PLATE CENTERED AND WELDED TO FRAMING MEMBER

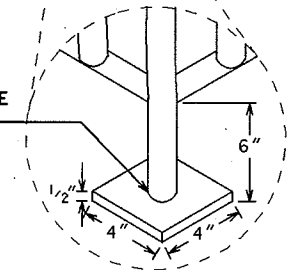

**NOTES:**

PAINTING SPECIFICATIONS FOR PAINTING REQUIREMENTS. SEE SECTION 506.2 (b) STRUCTURAL STEEL PAINT-EPOXY SYSTEM FOR STORM SEWER GATES

ALL DIMENSIONS ARE BAR CENTER TO BAR CENTER UNLESS OTHERWISE NOTED

BOX SIZE 'W' X 'H' (FEET)	T (IN)	NUMBER OF GATES	DIMENSIONS X Y (INCHES)		NUMBER OF BARS PER GATE (EXCLUDING FRAMING BARS) (EVENLY SPACED)		NUMBER OF HINGES PER GATE
			X	Y	VERTICAL	HORIZONTAL	
4X3	7 1/2	1	36	32.80	4	4	2
6X3	8	1	60	33.05	7	4	3
6X4	8	1	60	45.05	7	6	3
6X5	8	1	60	57.05	7	8	3
6X6	8	1	60	69.05	7	10	3
* 8X4	8	2	39	45.05	4	6	2
* 8X5	8	2	39	57.05	4	8	2
* 8X6	8	2	39	69.05	4	10	2
*10X6	10	2	51	70.05	6	10	3

\* WITH TWIN GATES THERE SHALL BE A 6" BETWEEN THE GATES (MEASURED TO THE CENTER OF THE FRAMING BARS)

CONSTRUCT WINGWALLS AND SPLASH PADS PER S.D.D. 5.5.1

2004

CITY OF MADISON  
ENGINEERING DIVISION

**BOX CULVERT  
INLET GATE  
(UPSTREAM)**

STANDARD DETAIL DRAWING 5.6.2



FRAMING MEMBERS:  
1 1/2" DIA. STANDARD  
STEEL PIPE (SCHEDULE 40)

HINGE SHALL BE MOUNTED CENTERED IN  
BOX ROOF. SEE HINGE DETAIL FOR  
CONSTRUCTION AND TABLE FOR QUANTITIES.

VERTICAL MEMBERS:  
1 1/2" DIA. STANDARD STEEL  
PIPE (SCHEDULE 40)

HORIZONTAL  
MEMBERS:  
3/4" DIA. ROD  
PER CHART

BOX CULVERT  
WITH WINGWALL

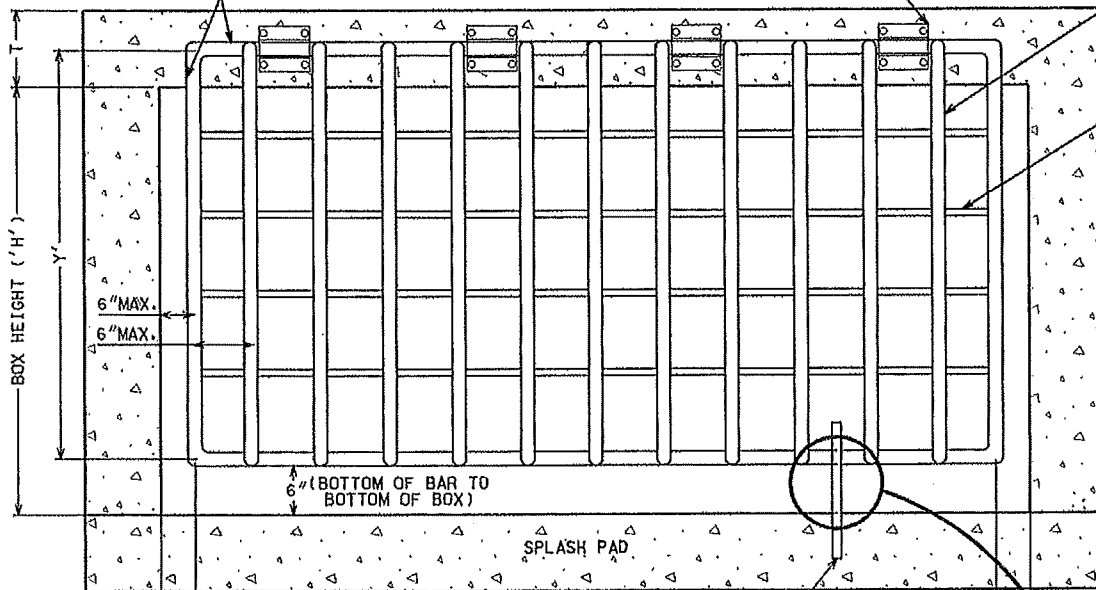

(P) 15" LONG 1" DOWELS INSTALLED DIRECTLY  
DOWNSTREAM OF GATE. DOWELS SHALL BE HELD  
IN PLACE WITH EPOXY. DOWELS SHALL BE EVENLY  
SPACED ALONG THE WIDTH OF THE GRATE.

**TWO PIECE SPLIT HINGE DETAIL**

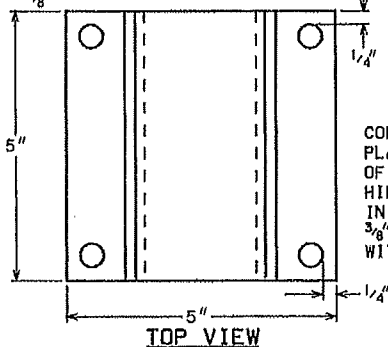
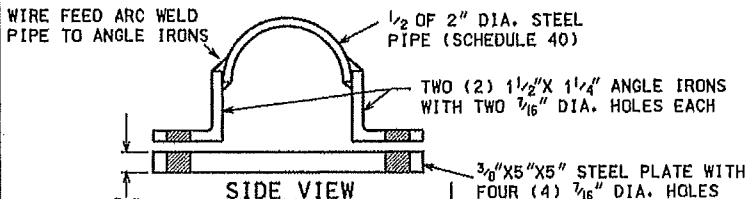

**INSTALLATION:**

CONNECT PIPE PIECE TO STEEL  
PLATE OVER TOP FRAMING MEMBER  
OF GRATE TO FORM HINGE. MOUNT  
HINGE TO THE BOX ROOF, CENTERED  
IN THE ROOF, USING FOUR (4)  
3/8" DIA. X 5" MACHINE BOLTS  
WITH ACKERMAN JOHNSON INSERTS

**PIN ASSEMBLY DETAIL**

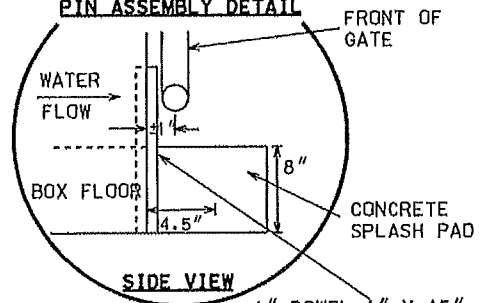

1" DOWEL 1" X 15"  
EMBEDDED 4 1/2" INTO  
THE CONCRETE PAD

**NOTES:**

PAINTING SPECIFICATIONS  
FOR PAINTING REQUIREMENTS, SEE SECTION  
506.2 (b) STRUCTURAL STEEL PAINT-EPOXY  
SYSTEM FOR STORM SEWER GATES

CONSTRUCT WINGWALLS AND  
SPLASH PADS PER S.D.D. 5.5.1

ALL DIMENSIONS ARE BAR CENTER TO BAR CENTER UNLESS OTHERWISE NOTED

BOX SIZE 'W' X 'H' (FEET)	T (IN)	NUMBER OF GATES	DIMENSIONS X Y (INCHES)		NUMBER OF BARS PER GATE (EXCLUDING FRAMING BARS) (EVENLY SPACED)		NO. OF HINGES PER GATE	NO. OF PINS PER GATE
			X	Y	VERTICAL	HORIZONTAL		
4X3	7 1/2	1	36	32.80	4	4	2	1
6X3	8	1	60	33.05	7	4	3	2
6X4	8	1	60	45.05	7	6	3	2
6X5	8	1	60	57.05	7	8	3	2
6X6	8	1	60	69.05	7	10	3	2
* 8X4	8	1	84	45.05	10	6	4	2
* 8X5	8	1	84	57.05	10	8	4	2
* 8X6	8	1	84	69.05	10	10	4	2
*10X6	10	1	108	70.05	13	10	5	3

2011

CITY OF MADISON  
ENGINEERING DIVISION

BOX CULVERT  
OUTLET GATE  
(DOWNSTREAM)

STANDARD DETAIL DRAWING 5.6.3

5.6.4

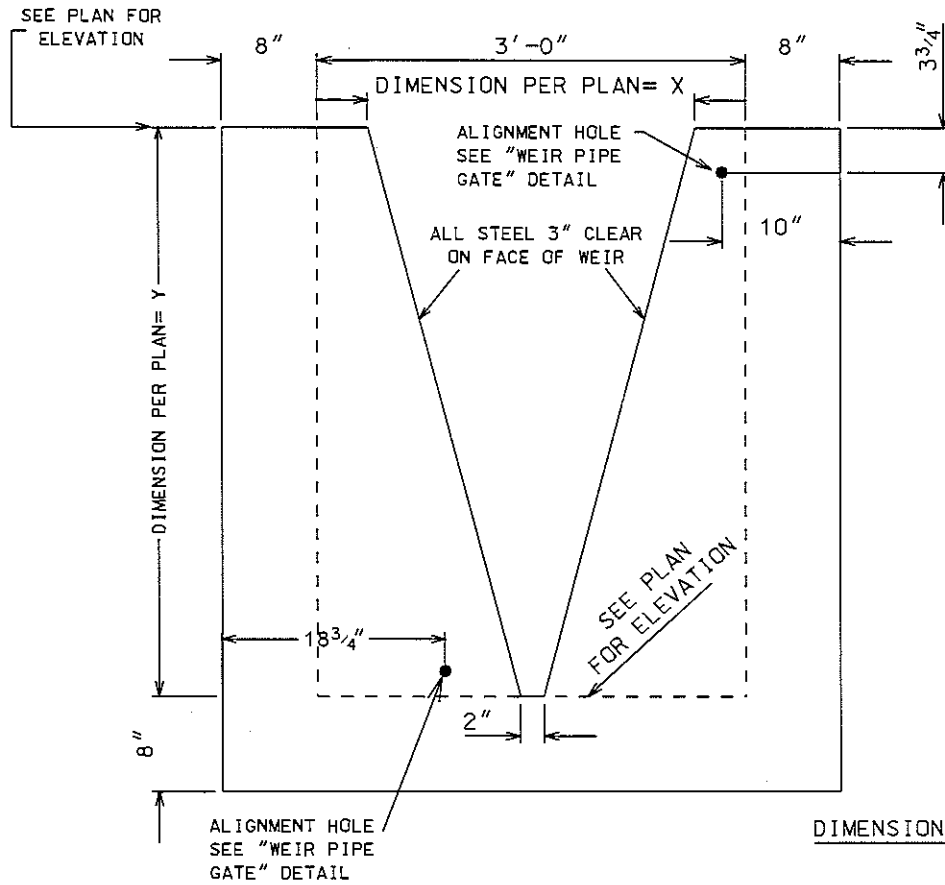

FRONT VIEW

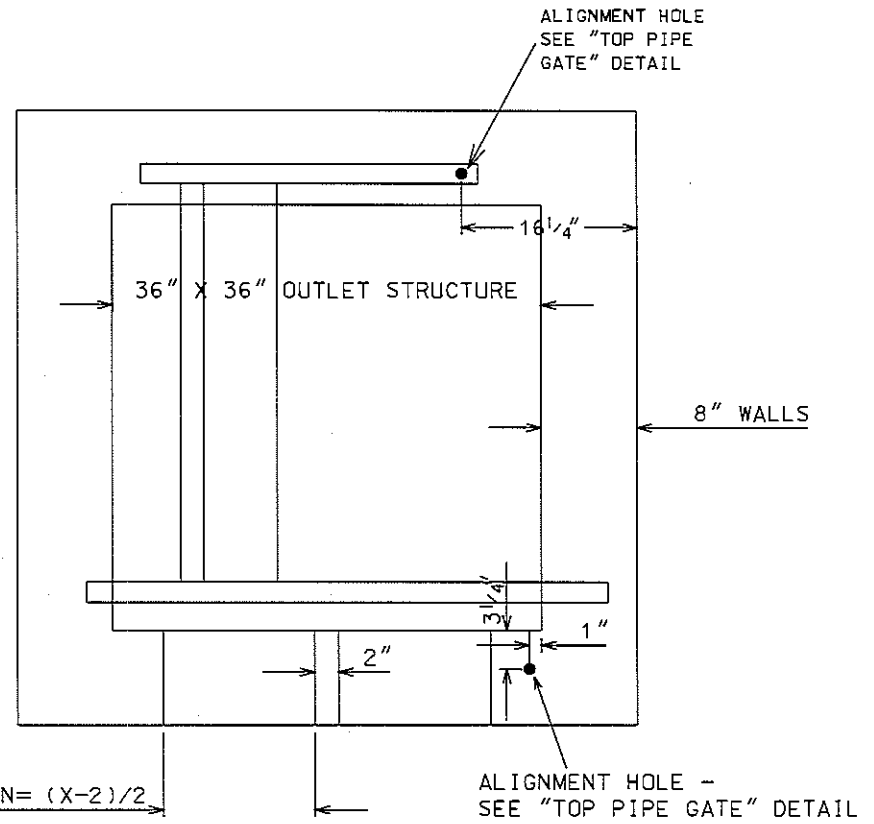

TOP VIEW

DIMENSION PER PLAN =  $(X-2)/2$

NOT TO SCALE

2008

CITY OF MADISON  
ENGINEERING DIVISION

STANDARD BASIN  
OUTLET STRUCTURE

STANDARD DETAIL DRAWING 5.6.4

ANCHOR BOLTS FOR GATES SHALL BE  $\frac{3}{8}$ " X 5" MACHINE BOLTS WITH ACKERMAN-JOHNSON INSERTS (8)

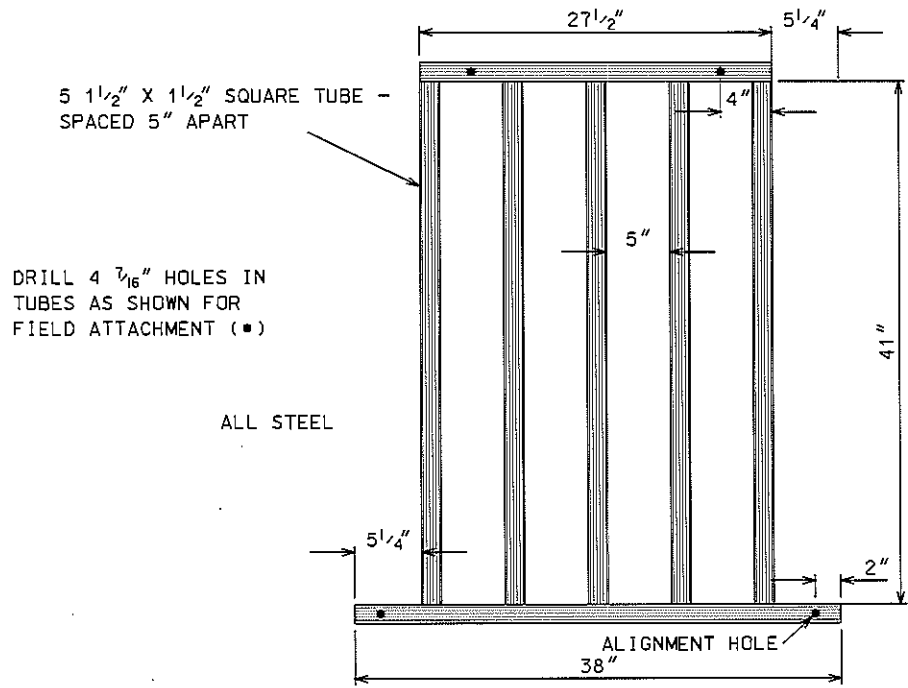

TOP PIPE GATE

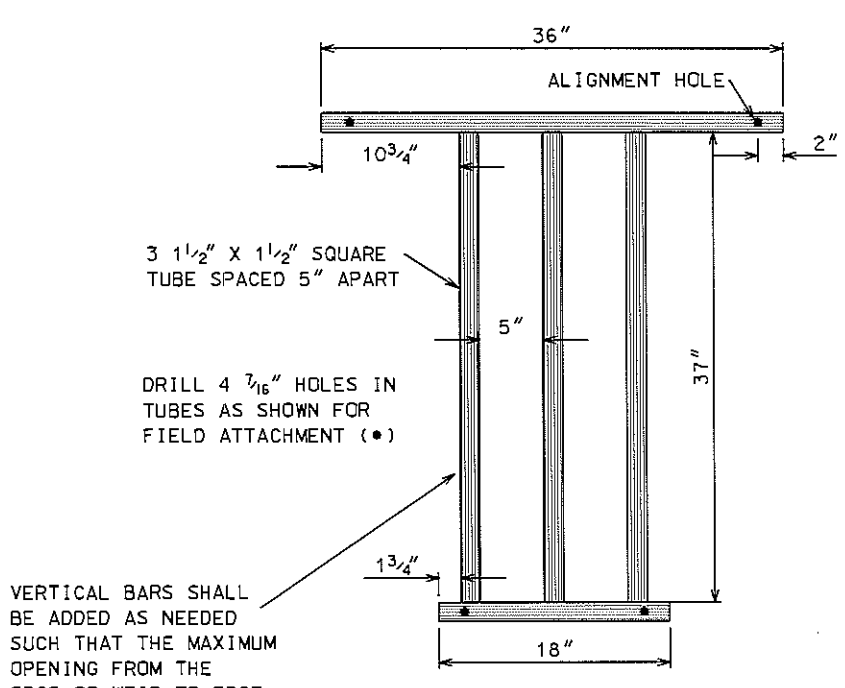

WEIR PIPE GATE

5.6.5

VERTICAL BARS SHALL BE ADDED AS NEEDED SUCH THAT THE MAXIMUM OPENING FROM THE EDGE OF WEIR TO EDGE OF BAR IS 5".

2008

CITY OF MADISON ENGINEERING DIVISION
STANDARD-BASIN OUTLET PIPE GATE DETAIL
STANDARD DETAIL DRAWING 5.6.5

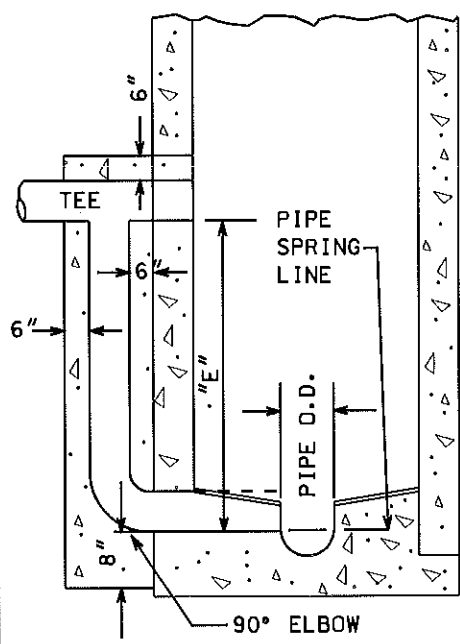
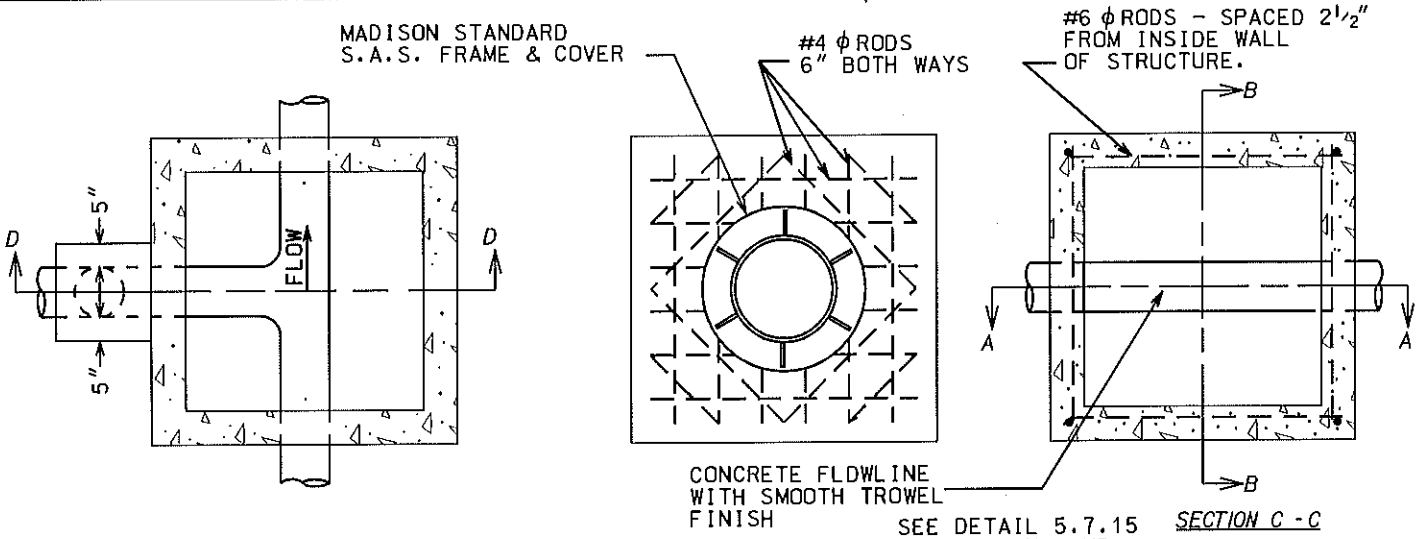

**SECTION D - D**  
 DROP INLET CONSTRUCTION FOR  
 SANITARY SEWER MAINS AND LATERALS

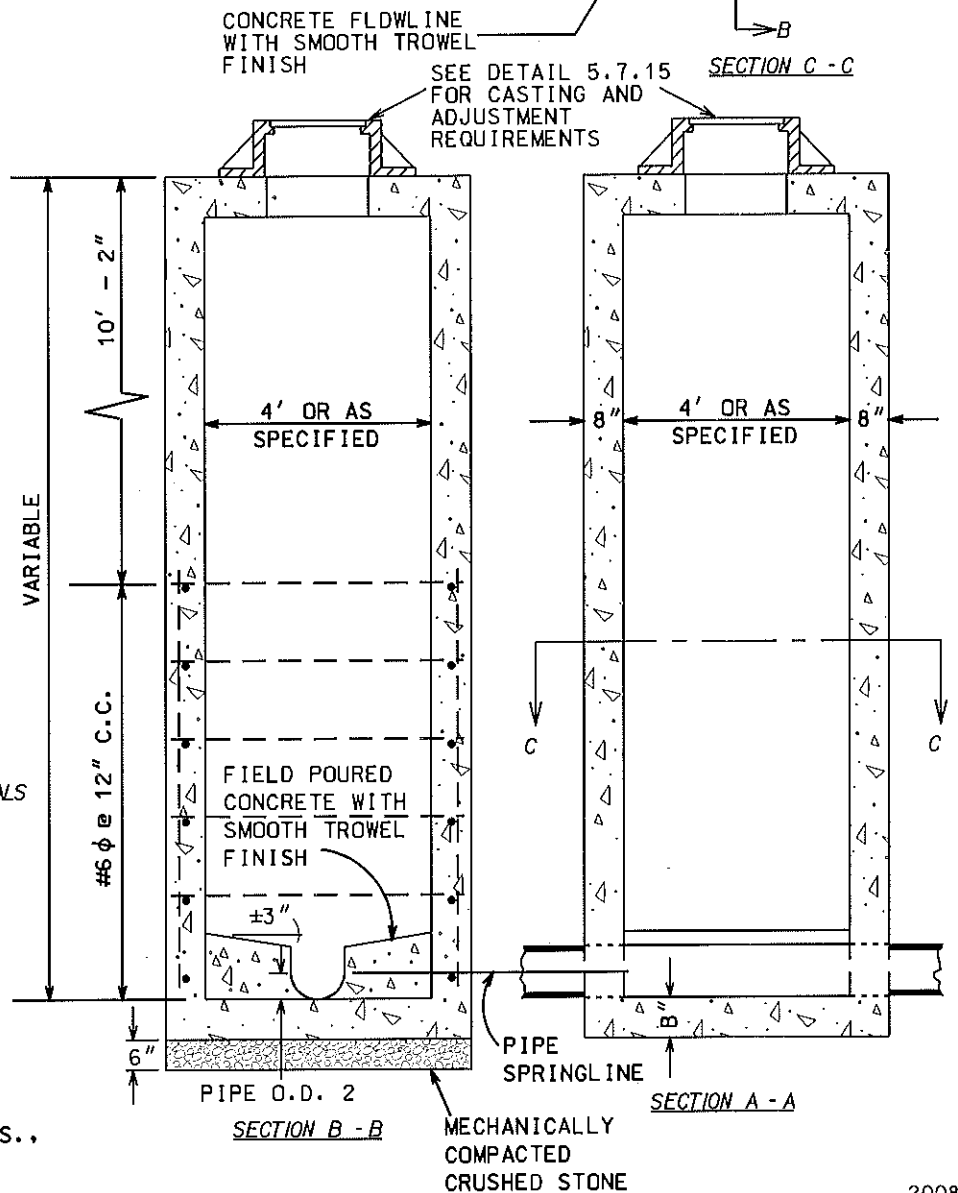

**NOTES:**

DROP INLET TO BE BUILT AT ALL S.A.S. WHEN DISTANCE "E" IS GREATER THAN 24". "E" SHOULD BE MEASURED FROM INVERT OF INCOMING PIPE TO THE SPRING-LINE OF THE OUTGOING SEWER.

ON 4'X4' & 5'X5' S.A.S., CENTER CASTING ON S.A.S.; ON 6'X6' S.A.S., CENTER OF CASTING TO BE 2' FROM OUTSIDE WALL OF S.A.S..

THICKNESS OF FLOOR (DIMENSION "B") TO BE 8" UP TO 10' DEPTHS & 12" FOR GREATER DEPTHS.

REFER TO STANDARD PLATE 5.7.16 "MADISON STANDARD FRAMES WITH NON-ROCKING COVER" FOR CASTING DESIGNATION.

ROOF THICKNESS SHALL BE 8" MINIMUM UNLESS SPECIFIED OTHERWISE.

2008

CITY OF MADISON ENGINEERING DIVISION
<b>SANITARY SEWER CAST-IN-PLACE SAS</b>
STANDARD DETAIL DRAWING 5.7.1

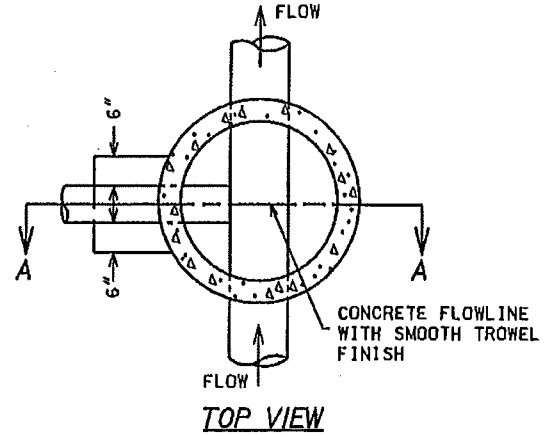
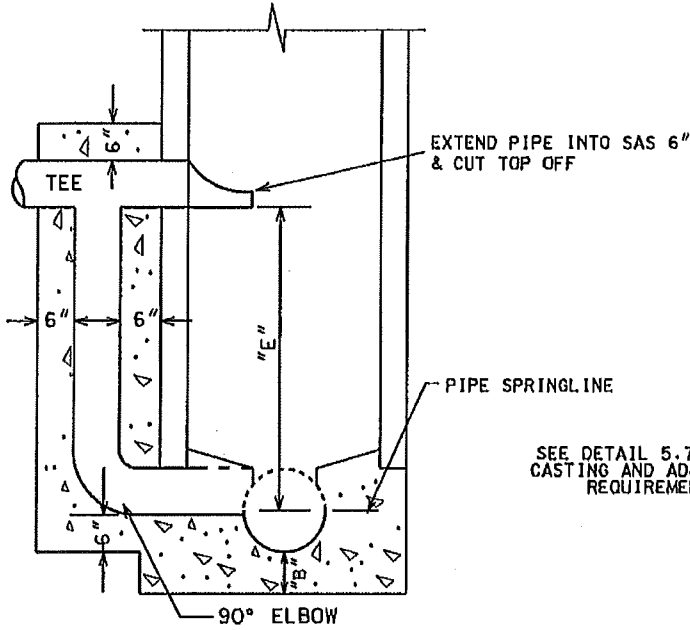

SEE DETAIL 5.7.15 FOR  
CASTING AND ADJUSTMENT  
REQUIREMENTS

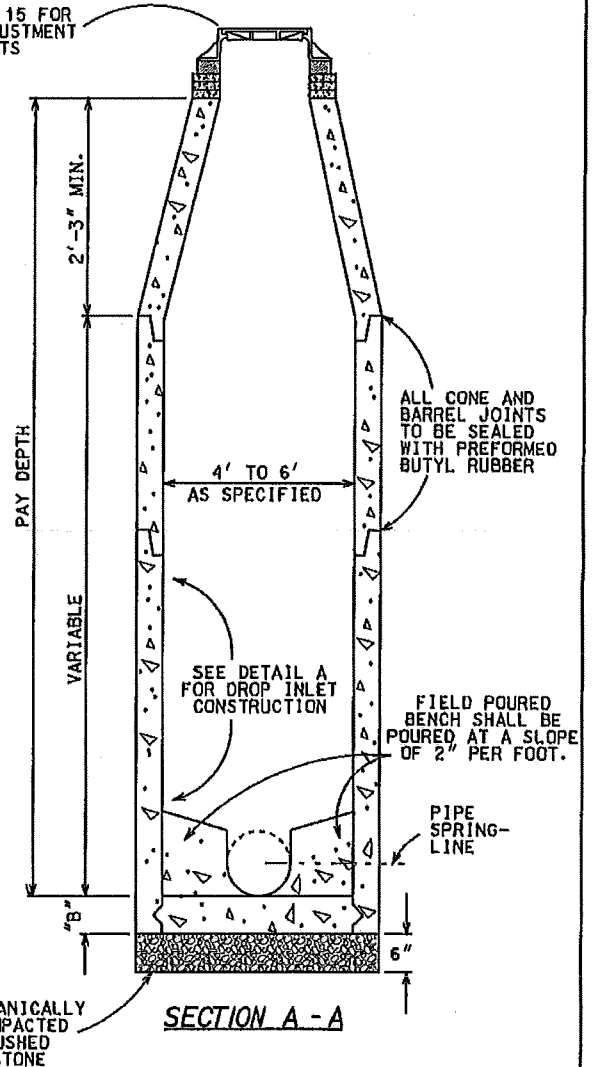

**DETAIL A**  
SHOWING DROP INLET CONSTRUCTION  
FOR SANITARY SEWER MAINS & LATERALS

**NOTES:**

- 1) PRECAST S.A.S. SECTIONS SHALL BE CONSTRUCTED IN ACCORDANCE WITH ASTM C-478.
- 2) THICKNESS OF BASE, "B":  
6" MIN. FOR 4' DIAMETER SAS  
8" MIN. FOR 5' AND 6' DIAMETER SAS
- 3) FOR CASTING DESIGNATION REFER TO STANDARD DETAIL DRAWING 5.7.16
- 4) CENTERED (CONCENTRIC) CONE SHALL BE INSTALLED UNLESS OTHERWISE DIRECTED.
- 5) DROP INLET SHALL BE BUILT FOR ALL SEWER MAINS AND LATERALS WHEN "E" IS GREATER THAN 24". "E" SHOULD BE MEASURED FROM INVERT OF INCOMING PIPE TO THE SPRINGLINE OF THE OUTGOING SEWER. INSIDE DROP PER STANDARD DETAIL DRAWING 5.7.30 MAY BE INSTALLED FOR 4" AND 6" SERVICE CONNECTIONS WHERE OUTSIDE DROP INLET CONSTRUCTION IS INFEASIBLE. ENGINEER SHALL APPROVE INSIDE DROP INLET PRIOR TO INSTALLATION.
- 6) FLEXIBLE PIPE TO SAS CONNECTOR REQUIRED PER STANDARD DETAIL DRAWING 5.7.31
- 7) ALL BENCHES TO BE FIELD POURED CONCRETE WITH SMOOTH TROWEL FINISH. PRECAST BENCHES ONLY PERMITTED WITH PRIOR APPROVAL OF ENGINEER IN WRITING.
- 8) ALL JOINTS BETWEEN RINGS SHALL BE SEALED WITH  $\frac{3}{8}$ " OF AIR-ENTRAINED TYPE M OR S MORTAR. THE OUTSIDE SURFACE OF THE ADJUSTING RINGS SHALL BE SEALED WITH A  $\frac{1}{2}$ " THICK AIR-ENTRAINED MORTAR TYPE M OR S SEAL. THE METHOD USED FOR SEALING THE OUTSIDE SURFACE SHALL BE COMPATIBLE WITH THAT USED TO SEAL JOINTS BETWEEN THE RINGS.
- 9) PRECAST SANITARY SEWER ACCESS STRUCTURES FOR STREET RECONSTRUCTION PROJECTS AND FOR STREET EXCAVATION PERMITS REQUIRE PRECAST SHOP DRAWING APPROVAL FROM CITY ENGINEERING. PRIOR TO BEING FABRICATED BY THE MANUFACTURER NO PRECAST SHOP DRAWINGS ARE REQUIRED FOR NEW CONSTRUCTION IN SUBDIVISION DEVELOPMENTS.

2010

CITY OF MADISON ENGINEERING DIVISION
<h2 style="margin: 0;">SANITARY SEWER PRECAST SAS</h2>
STANDARD DETAIL DRAWING 5.7.2

# SEWER ACCESS STRUCTURES

## ROOF REINFORCEMENT NOTES:

- 1) EPOXY COATED REBARS SHALL BE USED IN ALL CASES
- 2) #6 BARS PLACED ON 6" CENTERS FOR 3'X3', 3'X4', 4'X4', 4'X5', 5'X5' STRUCTURES
- 3) #6 BARS PLACED ON 4" CENTERS FOR 6'X5', 6'X6' AND LARGER STRUCTURES
- 4) 3" CLEAR SHALL BE MAINTAINED IN ALL CASES
- 5) ROOF THICKNESS SHALL BE 8" MINIMUM UNLESS SPECIFIED OTHERWISE.

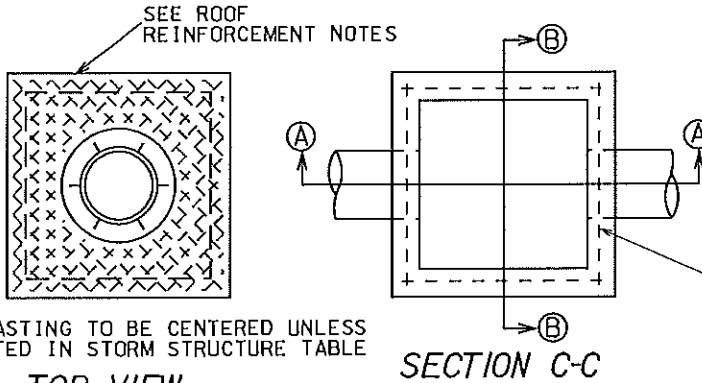

NOTE: CASTING TO BE CENTERED UNLESS NOTED IN STORM STRUCTURE TABLE

#6 BARS CENTERED IN WALL

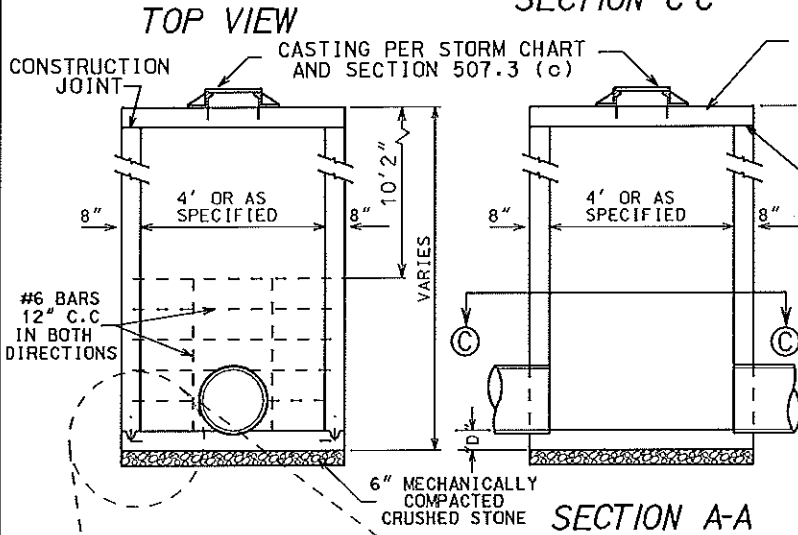

NOTE: THICKNESS OF FLOOR (DIMENSION "D") TO BE 8" UP TO 10' DEPTHS AND 10" FOR GREATER DEPTHS

## 3'X3' CATCH BASIN

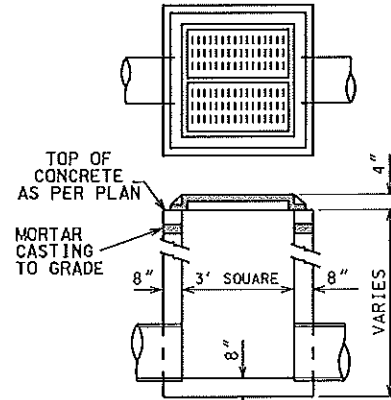

PRECAST REINFORCED CONCRETE STRUCTURES MAY BE USED IF APPROVED ACCORDING TO ARTICLES 106.3 AND 507.3 (b) OF THE STANDARD SPECIFICATIONS

NEENAH FOUNDRY CASTINGS AS LISTED OR EQUAL. ALL CASTING WITH FLANGE AT BASE.

LIGHT DUTY	R-1879-A10G	FOR OPEN GRATE
	R-1879-A10L	FOR SOLID LID
HEAVY DUTY	R-1878-A10G	FOR OPEN GRATE
	R-1878-A10L	FOR SOLID LID

2012

CITY OF MADISON  
ENGINEERING DIVISION

STORM SEWER  
FIELD POURED SAS  
AND CATCH BASINS

STANDARD DETAIL DRAWING 5.7.3

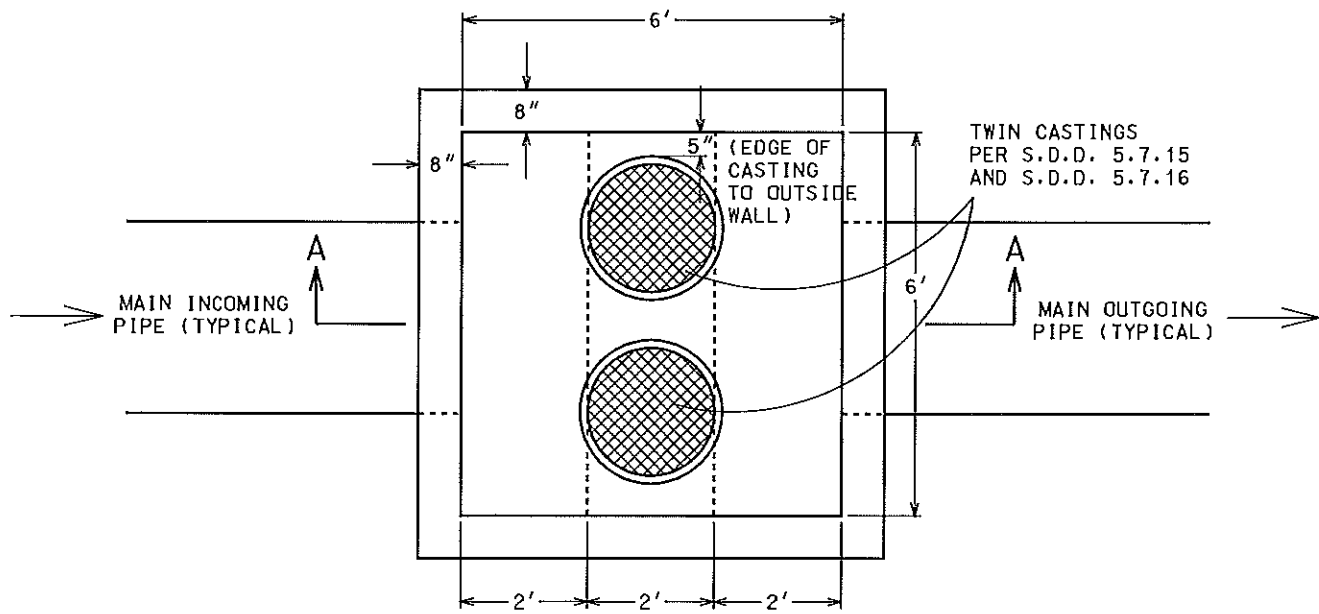

PLAN VIEW

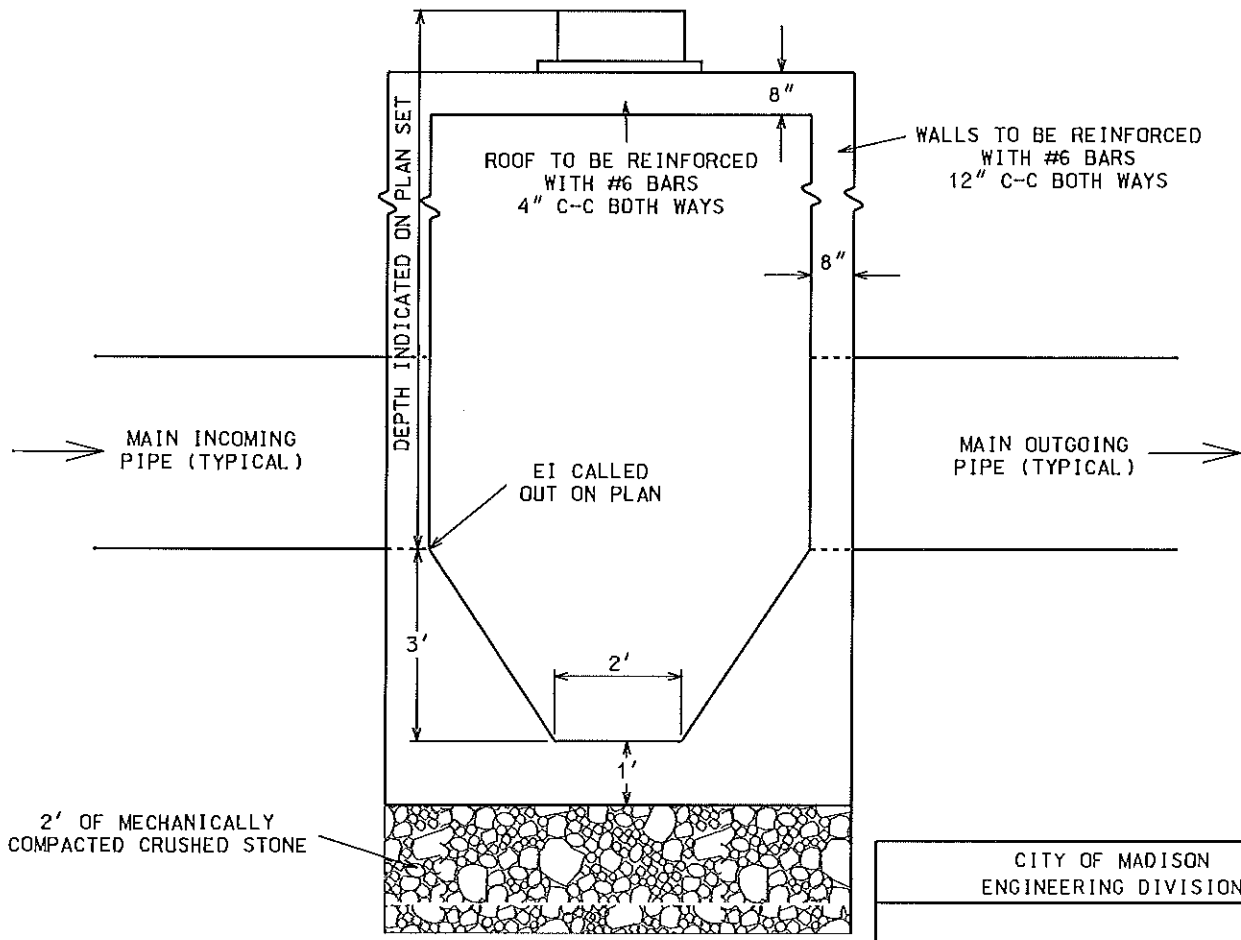

SECTION A-A

2012

CITY OF MADISON  
ENGINEERING DIVISION

---

STORM SEWER  
6' X 6' CATCH BASIN

---

STANDARD DETAIL DRAWING 5.7.4

5.7.5

SEE DETAIL 5.7.15  
FOR CASTING AND  
ADJUSTMENT REQUIREMENTS

ALTERNATE ROOF DETAIL

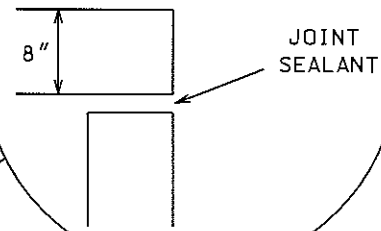

JOINT WILL BE SEALED WITH CONSEAL  
(CS - 102 OR CS - 202) DEPENDING ON  
FIELD TEMPERATURES

DIMENSION FROM BOTTOM OF GROOVE  
TO TOP OF CUT OUT SHALL BE SUCH THAT  
THE BOTTOM OF THE GROOVE IS INTACT.

CONCRETE COLLAR REQUIRED AROUND  
ALL PIPE/STRUCTURE CONNECTIONS.  
CONTRACTOR WILL USE A MECHANICAL  
VIBRATOR DURING CONSTRUCTION OF  
THE FLOOR AND COLLAR.

CIRCUMFERENTIAL  
ROUGH SCORED  
NOTCH CENTERED  
IN BASE

6" MECHANICALLY COMPACTED CRUSHED STONE

PIPE MAY BE PLACED  
AT ANY LOCATION IN  
CUT OUT PROVIDED  
INVERTS MATCH THOSE  
IN THE STORM TABLE

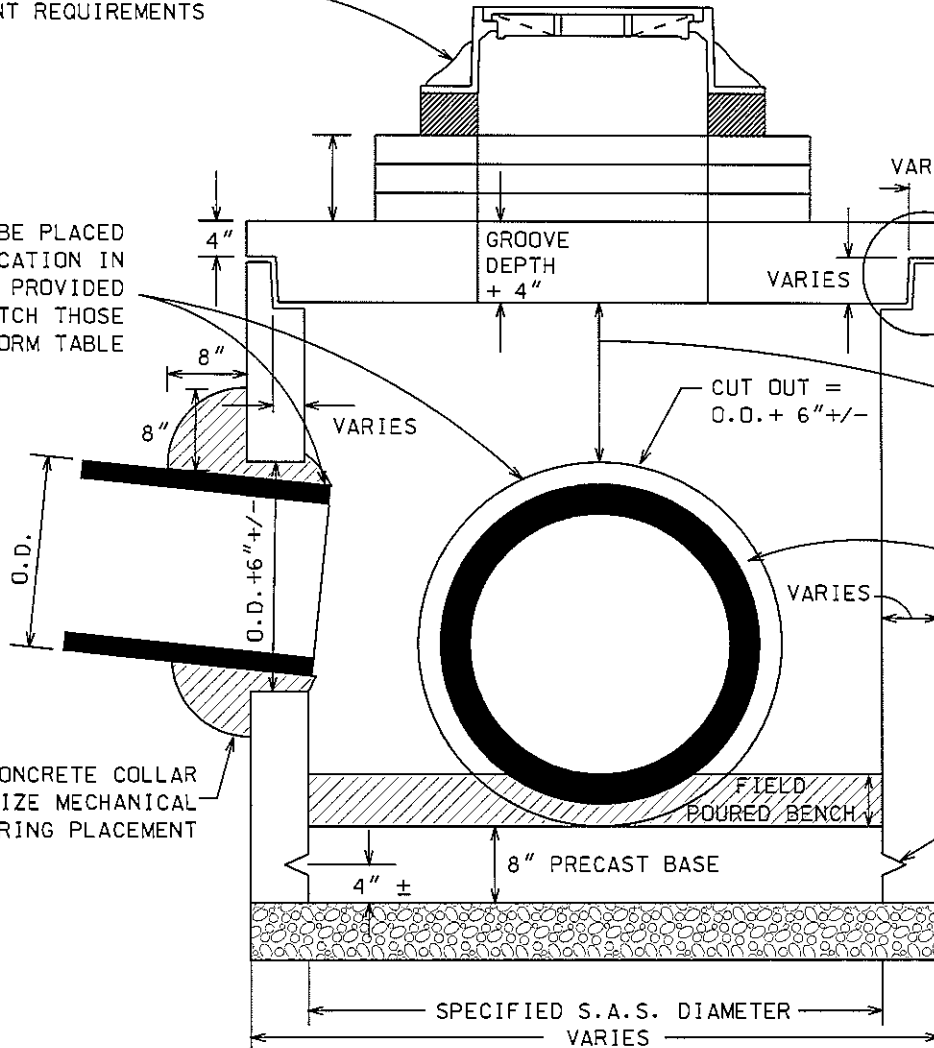

CONCRETE COLLAR  
SHALL UTILIZE MECHANICAL  
VIBRATOR DURING PLACEMENT

SPECIFIED S.A.S. DIAMETER  
VARIES

2006

CITY OF MADISON  
ENGINEERING DIVISION

STORM SEWER  
PRECAST SAS  
(THROUGH SECTION VIEW)

STANDARD DETAIL DRAWING 5.7.5



NOTE: ALL STORM SEWER ACCESS STRUCTURES (S.A.S.) SHALL BE CONSTRUCTED IN COMPLIANCE WITH ASTM C478

NOTE: FOR STRAIGHT THROUGH PIPE ALIGNMENTS IN STORM SEWER ACCESS STRUCTURES THE MINIMUM DEGREE ALLOWED BETWEEN CUTOUTS SHALL BE 60°

PIPE SHALL BE CUT TO APPROXIMATELY MATCH THE INSIDE OF THE S.A.S.. PIPES SHALL BE CUT FROM THE INTERSECTION OF THE PIPE O.D. WITH THE STRUCTURE WALL TO THE CENTER OF THE PIPE AS SHOWN.

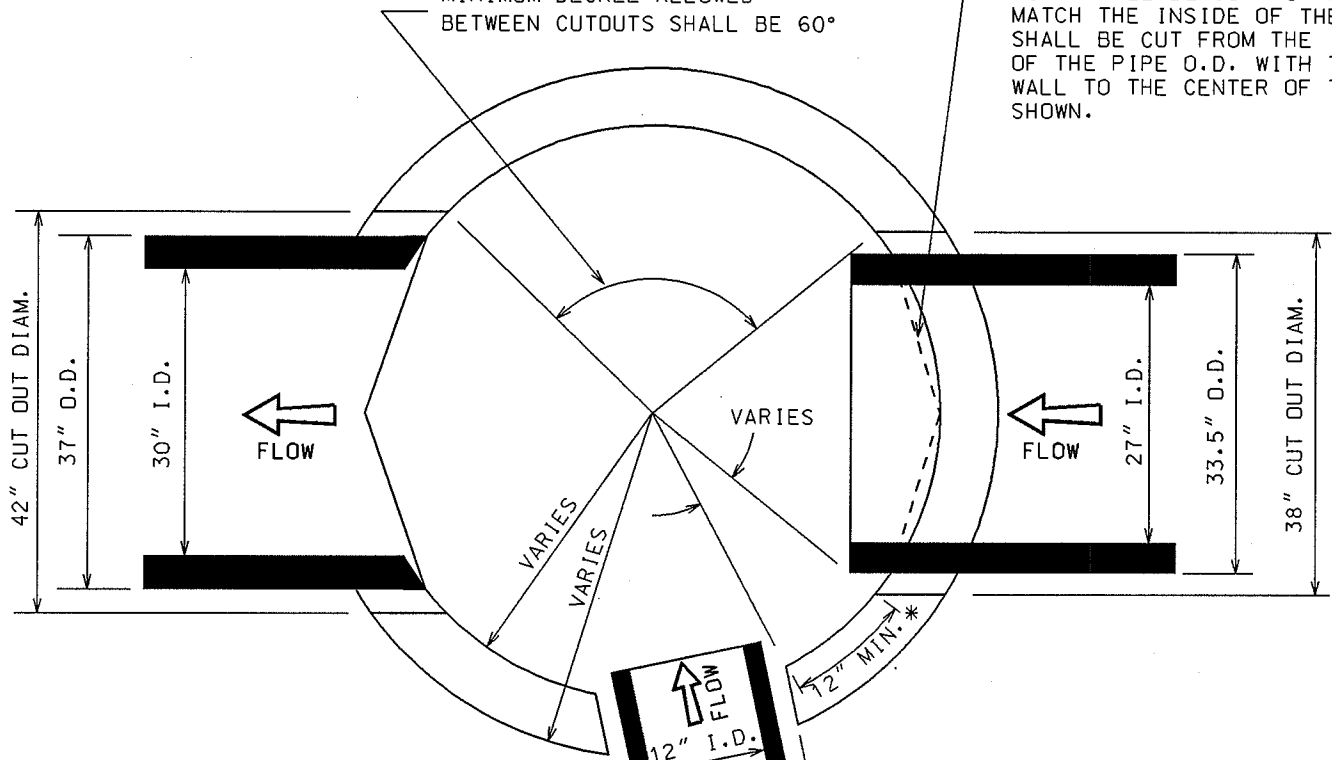

9.7.6

\* 12" OF CONCRETE MINIMUM, AS MEASURED ALONG THE INSIDE WALL RADIALLY FROM THE CLOSEST POINT BETWEEN CUTOUTS, SHALL BE PROVIDED IN THE DESIGN OF ALL PRECAST SEWER ACCESS STRUCTURES. WHEN MEASURED IN THE FIELD THIS DIMENSION SHALL BE ALLOWED TO BE 10" DUE TO MANUFACTURING TOLERANCES. STRUCTURES WITH LESS THAN 10" SHALL ONLY BE ALLOWED WITH THE CONSTRUCTION ENGINEER'S APPROVAL.

\*\* NOTE: PIPES SHOWN IN VARIOUS CONSTRUCTION STAGES FOR ILLUSTRATIVE PURPOSES.

2004
CITY OF MADISON ENGINEERING DIVISION
<b>STORM SEWER PRECAST SAS (TOP VIEW)</b>
STANDARD DETAIL DRAWING 5.7.6

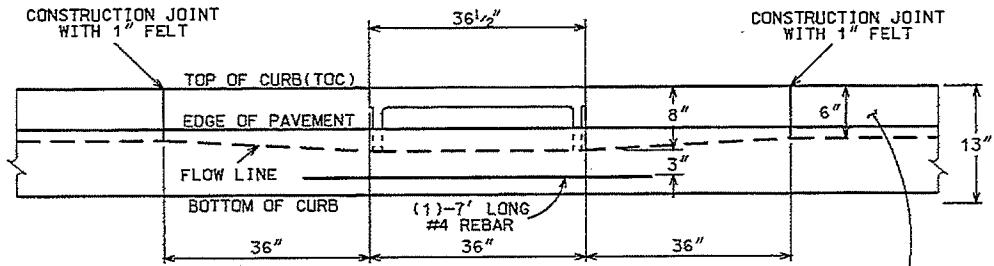

FRONT ELEVATION

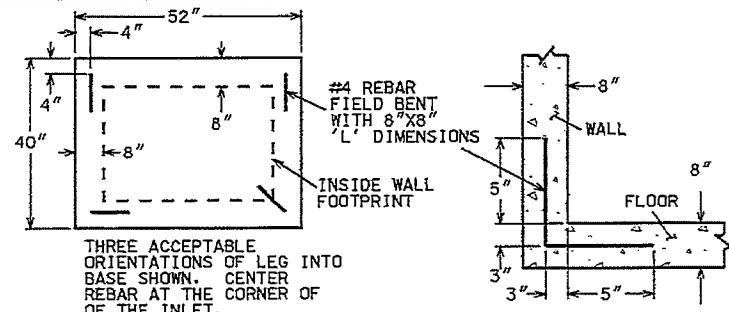

FIELD POURED FLOOR REINFORCEMENT

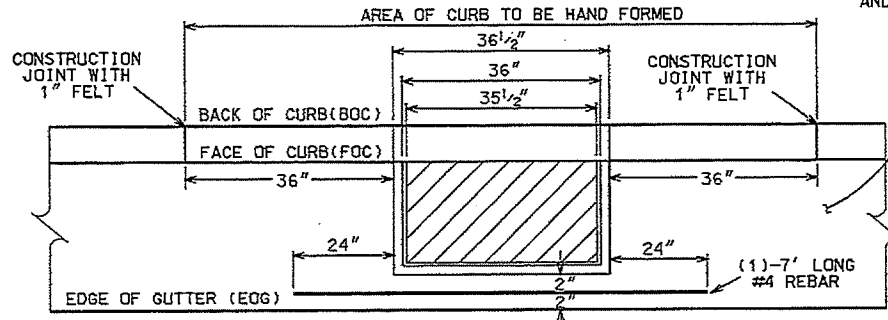

PLAN VIEW

NOTE: TYPE "A" CURB AND GUTTER SHOWN

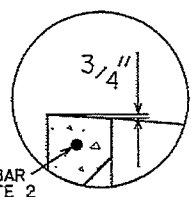

NOTE: 3/4" TILT CREATES SPECIFIED FLOW LINE DEPRESSION

INSET

- NOTES:
1. PRECAST REINFORCED CONCRETE STRUCTURES MAY BE USED IF APPROVED ACCORDING TO SECTION 106.3, 507.3 (b) OF THE STANDARD SPECIFICATIONS.
  2. INSTALLATION COST OF INLETS SHALL INCLUDE THE COST OF REINFORCING BARS AS FOLLOWS:
    - (1) - #4 BARS 7'-0" LONG IN CONCRETE GUTTER ALONG THE FRONT OF INLET.
    - (4) #4 REBARS FIELD BENT WITH 8"x8" 'L' DIMENSIONS.
  3. WHEN AN "S" INLET IS SPECIFIED, THE INSIDE DIMENSIONS OF THE STANDARD "H" INLET SHALL BE ALTERED TO 2'-4" x 1'-6".
  4. PRECAST INLETS REQUIRE 2" OF CONCRETE FROM THE EDGE OF CUTOFF/KNOCKOUT TO THE INSIDE WALLS AND TO THE TOP OF STRUCTURE.
  5. FIELD POURED STRUCTURES SHALL HAVE A BENCH POURED INSIDE TO THE SPRINGLINE OF THE PIPES CREATING A POSITIVE LOW FLOW CHANNEL AS SHOWN IN THE TYPICAL FRONT SECTION VIEW.
  6. ASSUMING 90 DEGREE PIPE CONNECTIONS, THE MAXIMUM PIPE OUT A 3' SIDE IS 24" AND THE MAXIMUM PIPE OUT A 2' SIDE IS 12".
  7. WALL THICKNESS DIMENSIONS OF 8" AND 5" CORRESPOND TO CAST-IN-PLACE AND PRECAST STRUCTURES, RESPECTIVELY.
  8. THERE SHALL BE AN 8" FLOWLINE DEPRESSION FROM TOC ALONG THE INLET TAPERED FROM THE TYPICAL 6" FLOWLINE AS SHOWN IN THE FRONT ELEVATION.
  9. SEE STANDARD DETAIL DRAWING 5.7.29 FOR INLET CASTING OFFSET CRITERIA FOR H INLETS.
  10. FLOOR REINFORCEMENT REQUIRED IN ALL FIELD POURED INLETS

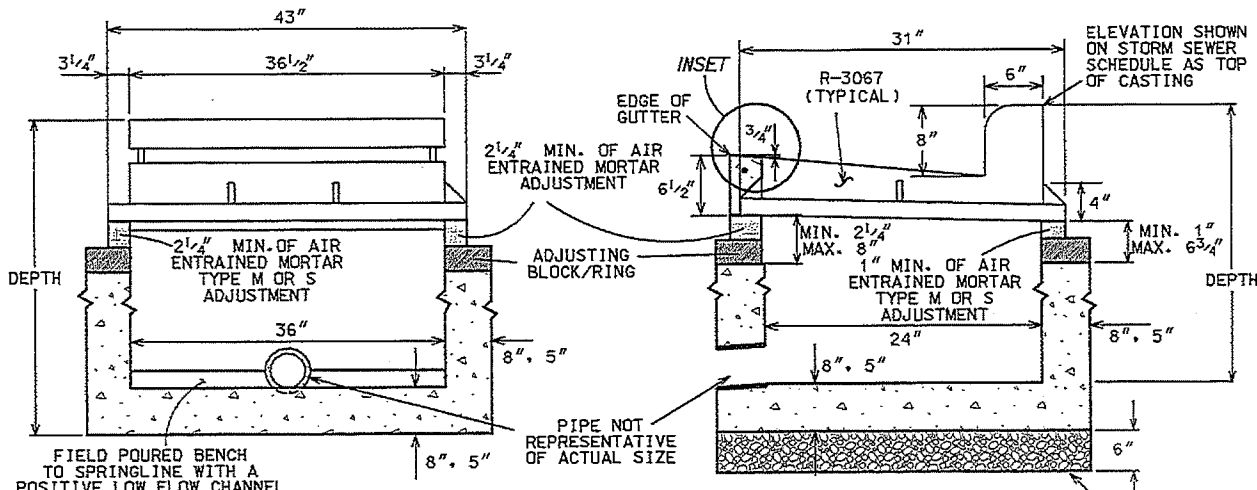

TYPICAL FRONT SECTION

TYPICAL SECTION

DRAWING NOT TO SCALE

5.7.7

2011

CITY OF MADISON  
ENGINEERING DIVISION

TYPE "H"  
INLET

STANDARD DETAIL DRAWING 5.7.7

3" MIN. - 8" MAX. OF ADJUSTING RINGS SHALL BE ALLOWED UNLESS NOTED IN PLAN SET

R-3067 (TYPICAL)

SEALING OF RINGS SHALL BE PER STANDARD DETAIL DRAWING 5.7.7

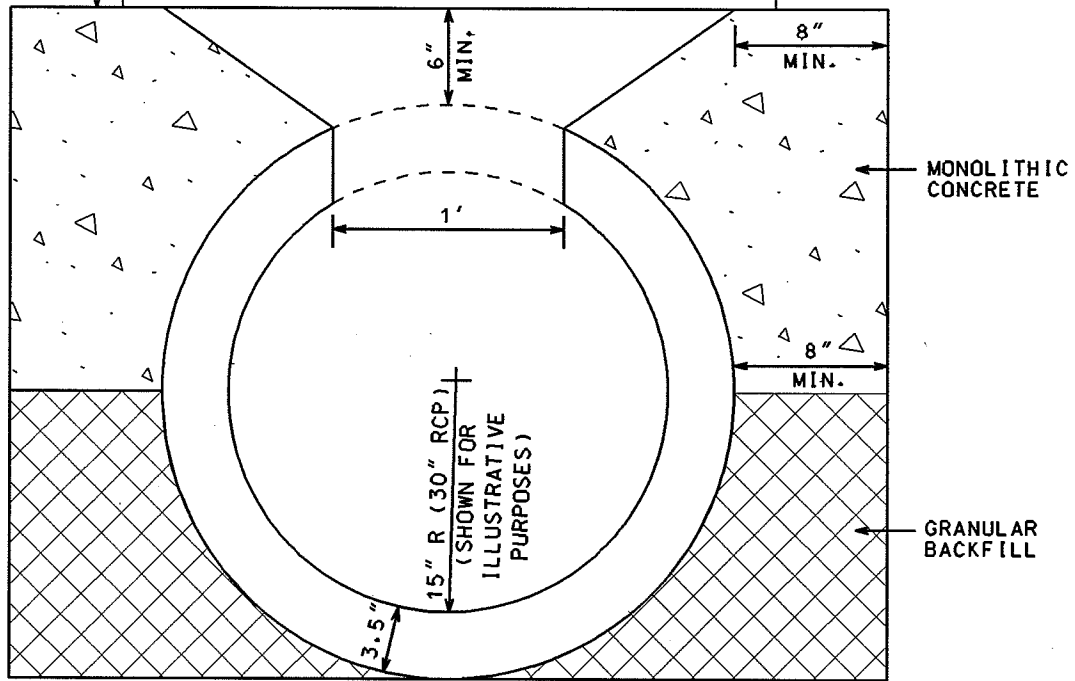

TO BE USED ON PIPES OR BOXES WHERE THE O.D. OF THE THROUGH PIPE IS LESS THAN OR EQUAL TO 4'-4".

2004
CITY OF MADISON ENGINEERING DIVISION
<b>MADISON STANDARD SADDLED INLET TYPE I</b>
STANDARD DETAIL DRAWING 5.7.8

3" MIN. - 8" MAX. OF ADJUSTING RINGS SHALL BE ALLOWED UNLESS NOTED IN PLAN SET

R-3067 (TYPICAL)

SEALING OF RINGS SHALL BE PER STANDARD DETAIL DRAWING 5.7.7

ADDITIONAL LONGITUDINAL REBAR ON 8" CENTER AS INLET DEPTH INCREASES

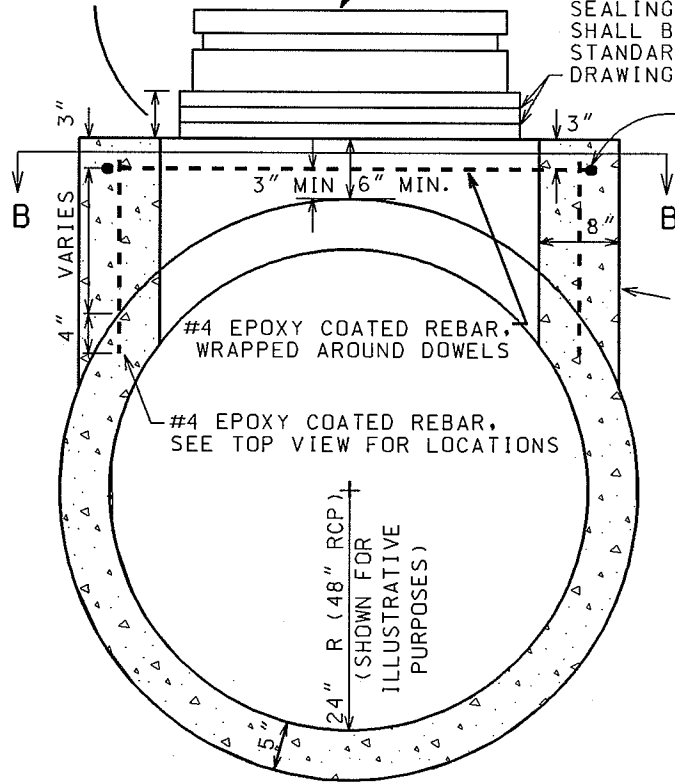

8" THICK MONOLITHIC CONCRETE WITH DOWELS AND REINFORCEMENT AS NOTED.

#4 EPOXY COATED REBAR, WRAPPED AROUND DOWELS

#4 EPOXY COATED REBAR, SEE TOP VIEW FOR LOCATIONS

24" R (48" RCP)  
(SHOWN FOR ILLUSTRATIVE PURPOSES)

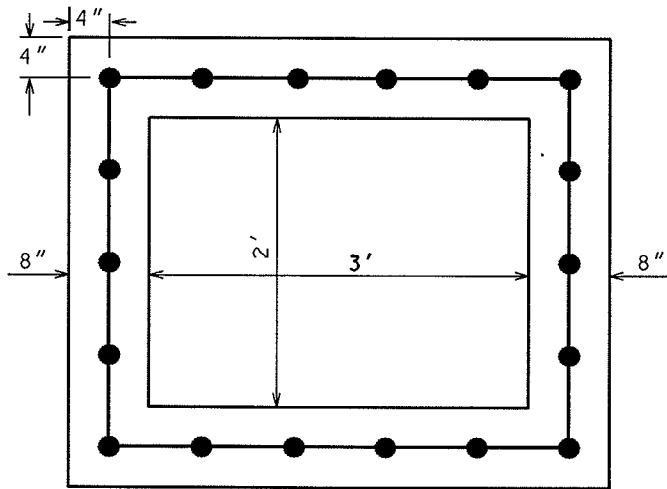

SECTION B - B

TO BE USED ON PIPES OR BOXES WHERE THE O.D. OF THE PIPE OR BOX IS GREATER THAN 4'-4".

2004

CITY OF MADISON  
ENGINEERING DIVISION

MADISON STANDARD  
SADDLED INLET  
TYPE II

STANDARD DETAIL DRAWING 5.7.9

**TYPE A**

FOR PIPES WITH DIAMETER LESS THAN OR EQUAL TO 24" INNER DIAMETER

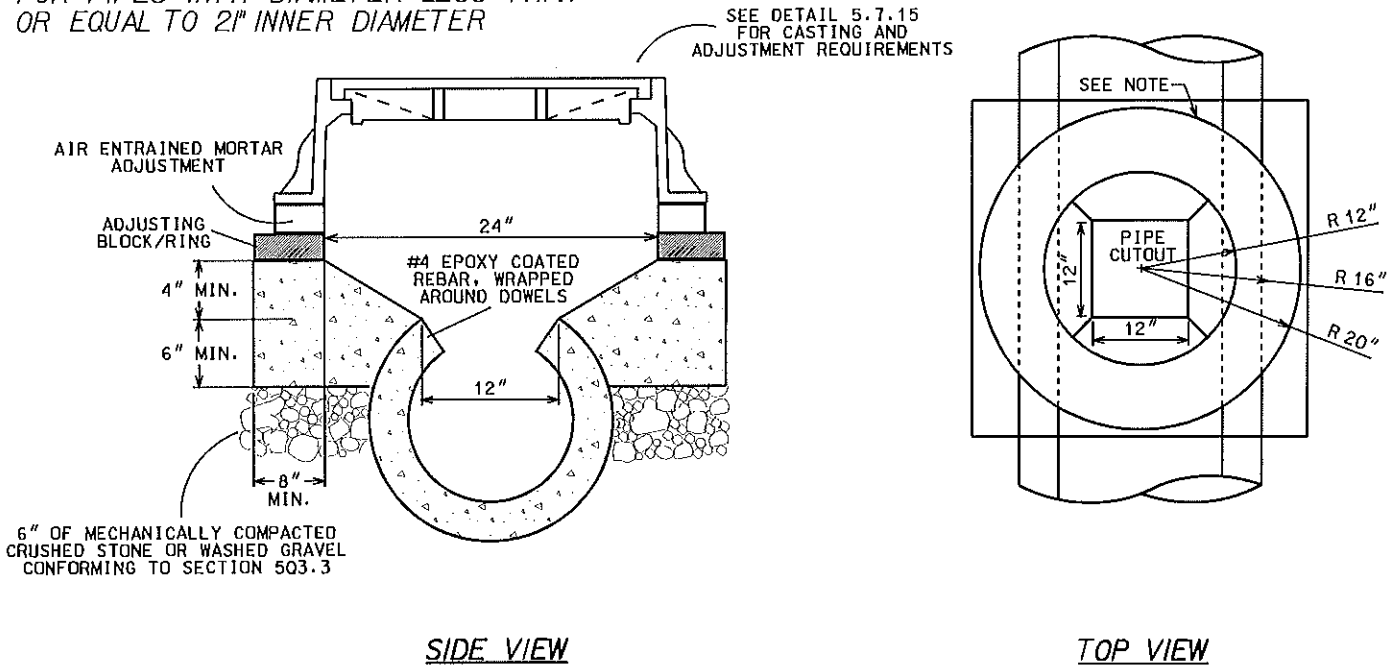

DRAWING NOT TO SCALE

**TYPE B**

FOR PIPES WITH DIAMETER GREATER THAN 24" INNER DIAMETER

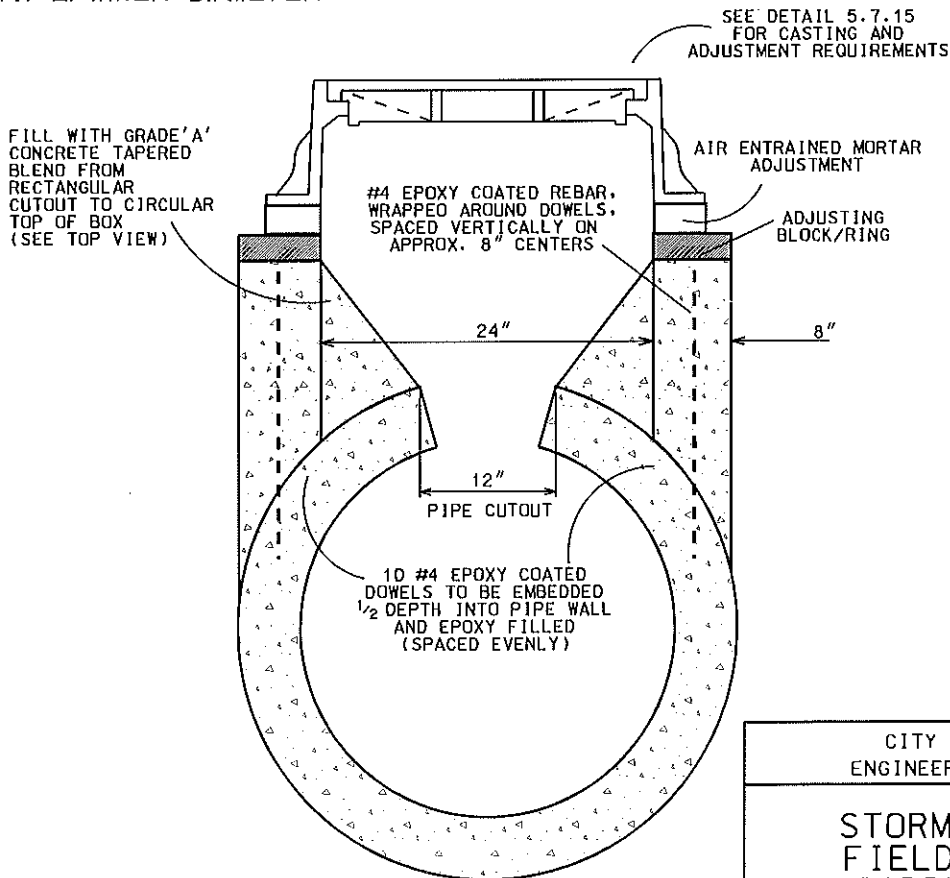

DRAWING NOT TO SCALE

2007

CITY OF MADISON  
ENGINEERING DIVISION

STORM SEWER  
FIELD POURED  
SADDLED SAS

STANDARD DETAIL DRAWING 5.7.9A

**TYPE A**

FOR PIPES WITH DIAMETER LESS THAN OR EQUAL TO 27" INNER DIAMETER

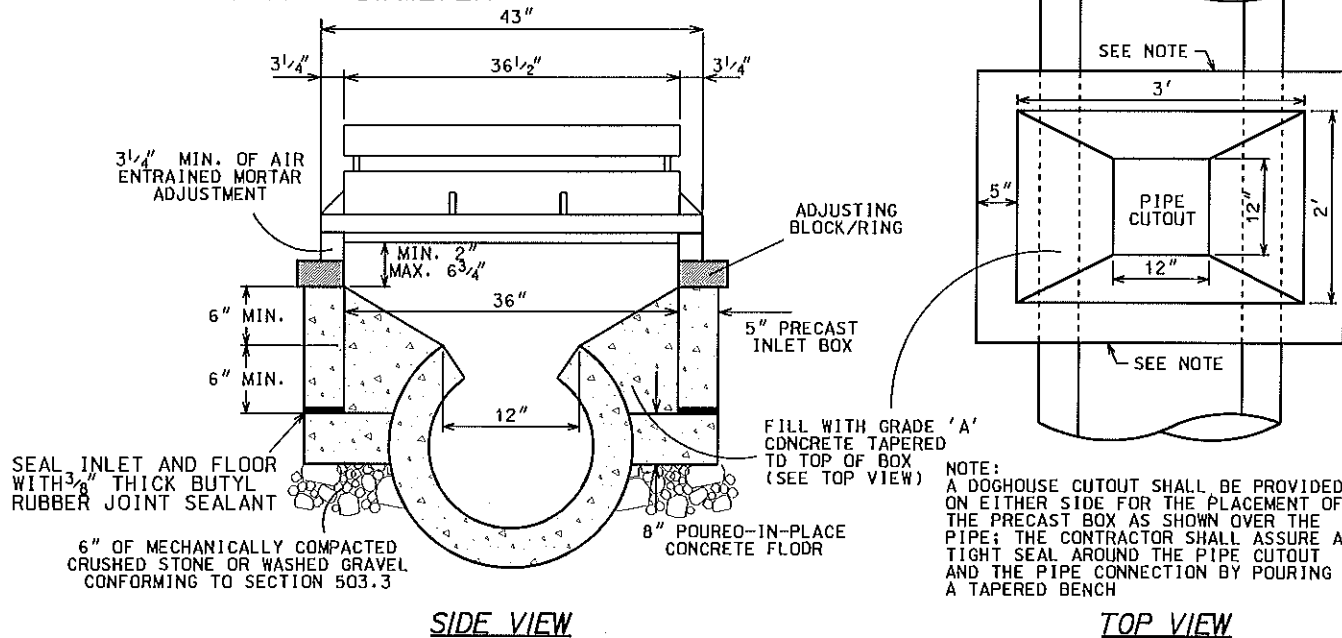

**TYPE B**

FOR PIPES WITH DIAMETER GREATER THAN 27" INNER DIAMETER

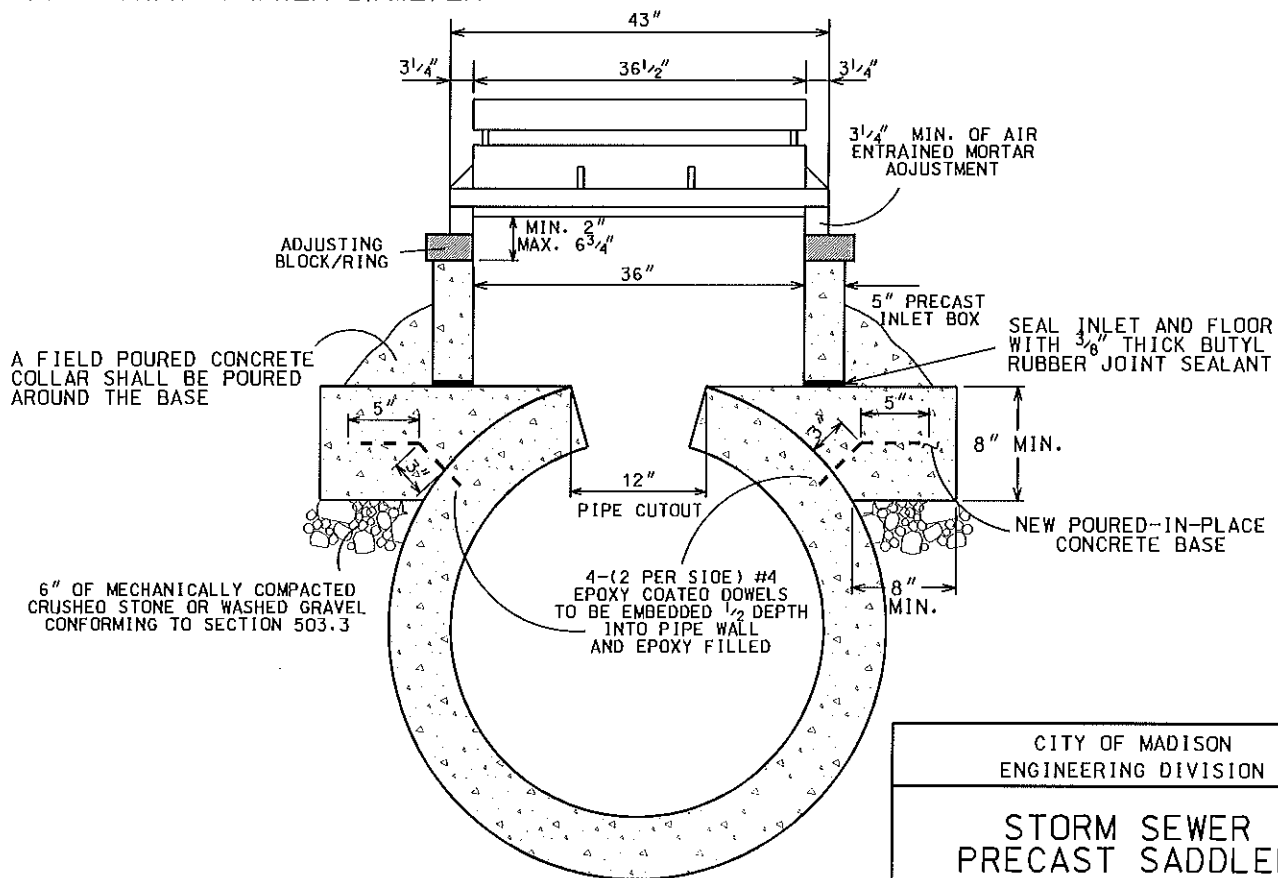

2006

CITY OF MADISON  
ENGINEERING DIVISION

STORM SEWER  
PRECAST SADDLED  
INLET

STANDARD DETAIL DRAWING 5.7.10

**TYPE A**

FOR PIPES WITH DIAMETER LESS THAN OR EQUAL TO 2" INNER DIAMETER

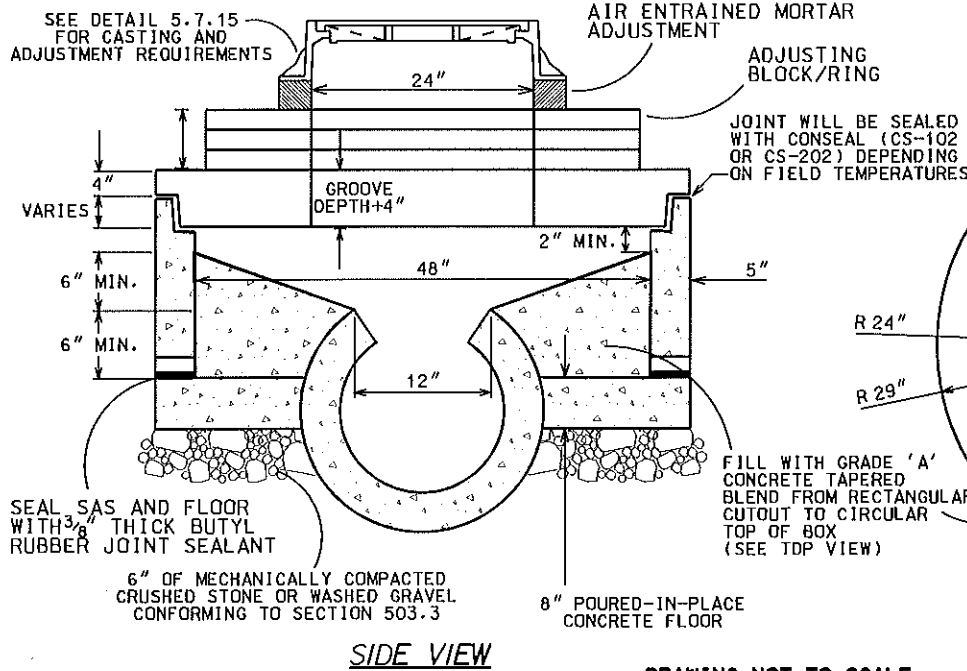

NOTE:  
A DOGHOUSE CUTOUT SHALL BE PROVIDED ON EITHER SIDE FOR THE PLACEMENT OF THE PRECAST BOX AS SHOWN OVER THE PIPE; THE CONTRACTOR SHALL ASSURE A TIGHT SEAL AROUND THE PIPE CUTOUT AND THE PIPE CONNECTION BY POURING A TAPERED BENCH

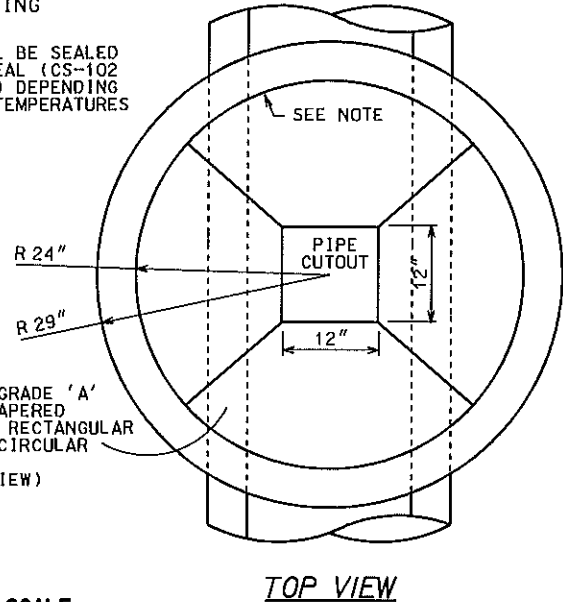

DRAWING NOT TO SCALE

**TYPE B**

FOR PIPES WITH DIAMETER GREATER THAN 2" INNER DIAMETER

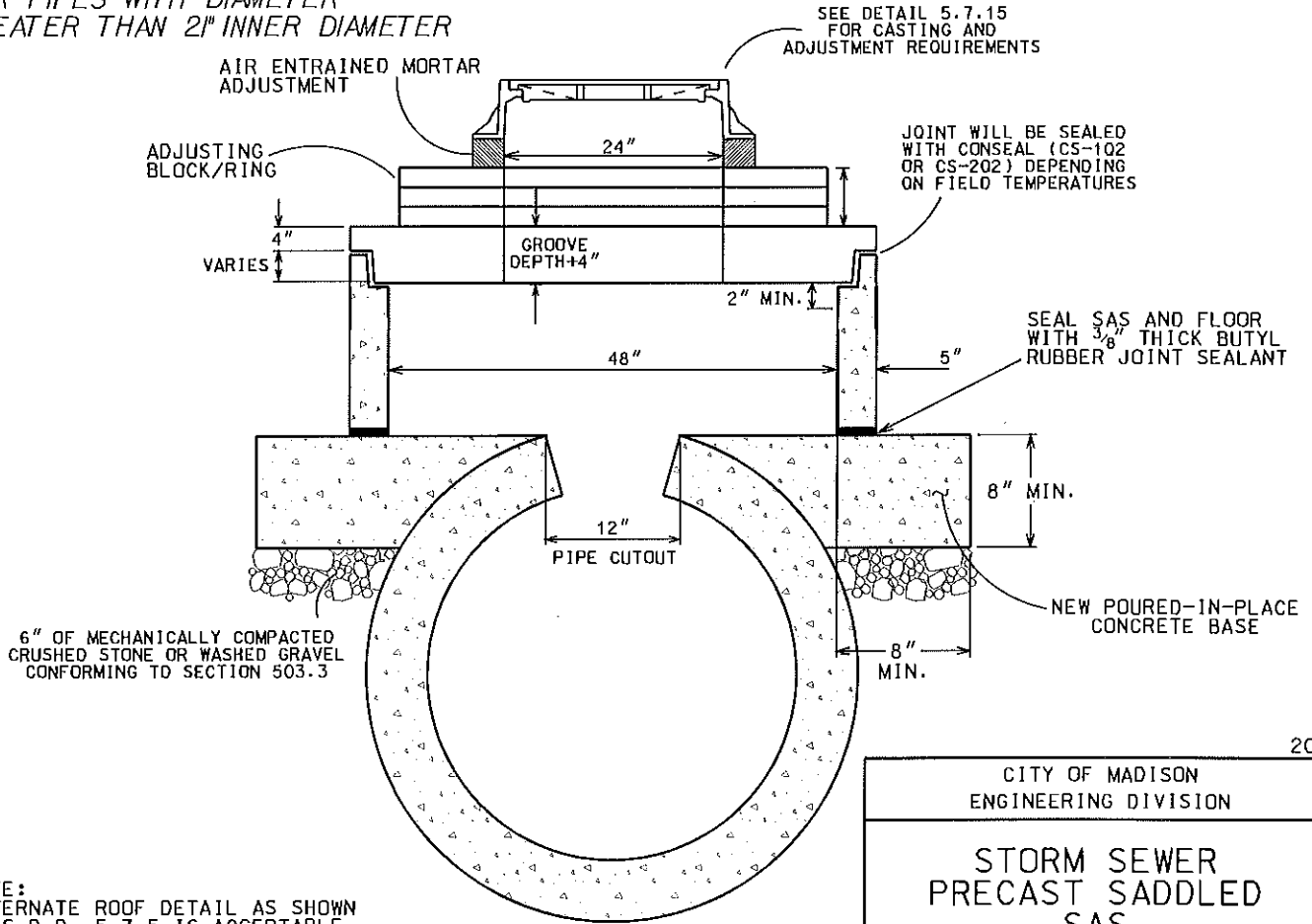

NOTE:  
ALTERNATE ROOF DETAIL AS SHOWN ON S.D.D. 5.7.5 IS ACCEPTABLE FOR BOTH TYPES A & B.

DRAWING NOT TO SCALE

2007

CITY OF MADISON  
ENGINEERING DIVISION

STORM SEWER  
PRECAST SADDLED  
SAS

STANDARD DETAIL DRAWING 5.7.10A

5.7.11

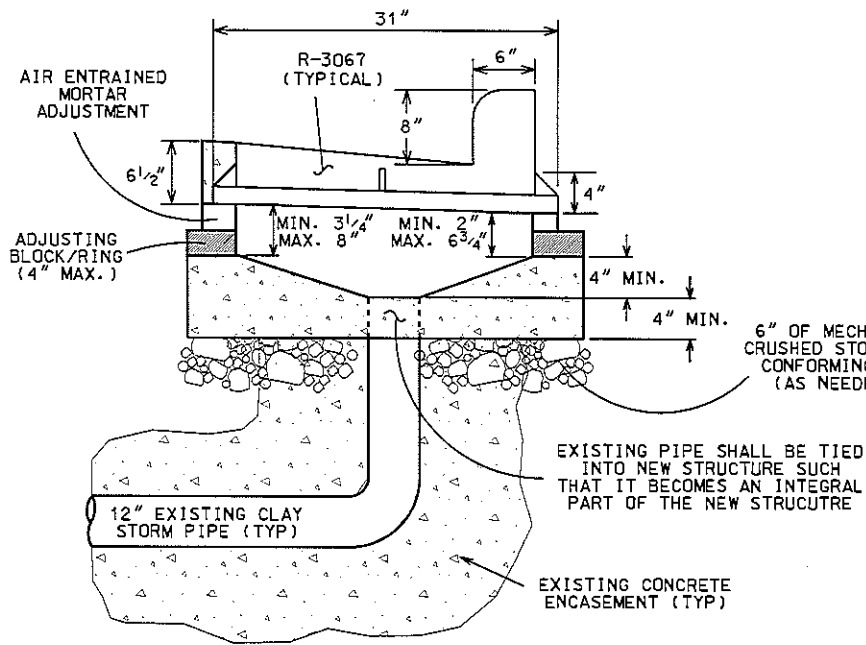

FIELD POUR OPTION

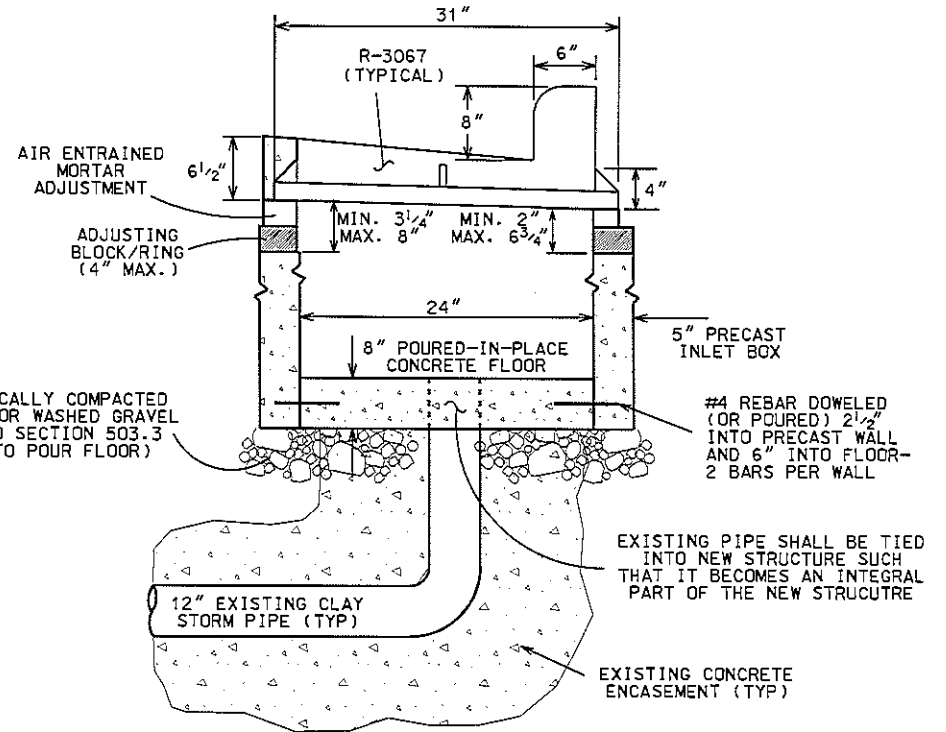

PRECAST OPTION

DESIGN OPTIONS:

(1) FIELD POUR-

PER THE DESIGN IN THE DETAIL DRAWING, THE MINIMUM DEPTH FOR THE FIELD POUR OPTION SHALL BE 19" (4" WALL + 2" MORTAR ADJUSTMENT + 13" CASTING) WITH AN ADDITIONAL MINIMUM 4" OF EXCAVATION REQUIRED FOR THE FLOOR.

(2) PRECAST

PER THE DESIGN IN THE DETAIL DRAWING, THE MINIMUM DEPTH FOR THE PRECAST OPTION SHALL BE 19" (12" INLET WALL - 8" FLOOR + 2" MORTAR ADJUSTMENT + 13" CASTING) WITH AN ADDITIONAL MINIMUM OF 8" OF EXCAVATION REQUIRED FOR THE FLOOR.

(3) FIELD STACKED

THE DESIGN CONSISTS OF AN 8" FIELD POURED CONCRETE FLOOR, STACKED ADJUSTMENT RINGS, AIR ENTRAINED MORTAR ADJUSTMENT, AND H CASTING.

THE MINIMUM DEPTH FOR THE STACKED OPTION SHALL BE 17" (2" ADJUSTMENT RING, 2" MORTAR ADJUSTMENT, 13" CASTING).

THE MAXIMUM DEPTH SHALL BE 19" (4" ADJUSTMENT RINGS, 2" MORTAR ADJUSTMENT, 13" CASTING)

GENERAL NOTES:

- (1) REMOVE EXISTING INLET AND CLAY PIPE TO A STABLE LOCATION
- (2) REMOVE MATERIAL SURROUNDING PIPE TO A DEPTH OF FOURTEEN (14) INCHES BEYOND THE STABLE LOCATION REFERRED TO ABOVE
- (3) INSTALL NEW INLET CASTING ADJUSTMENTS.
- (4) IF, TO FIND A STABLE PIPE LOCATION, THE EXISTING PIPE IS REMOVED BEYOND THE ELBOW, THE RECONSTRUCT TUB INLET SPECIFICATION IS NO LONGER APPLICABLE. THE RELEVANT ITEMS BECOME REMOVE INLET AND REPLACE WITH TYPE 'H' INLET.

DRAWINGS NOT TO SCALE

2006
CITY OF MADISON ENGINEERING DIVISION
<b>RECONSTRUCT TUB INLET</b>
STANDARD DETAIL DRAWING 5.7.11



5.7.12

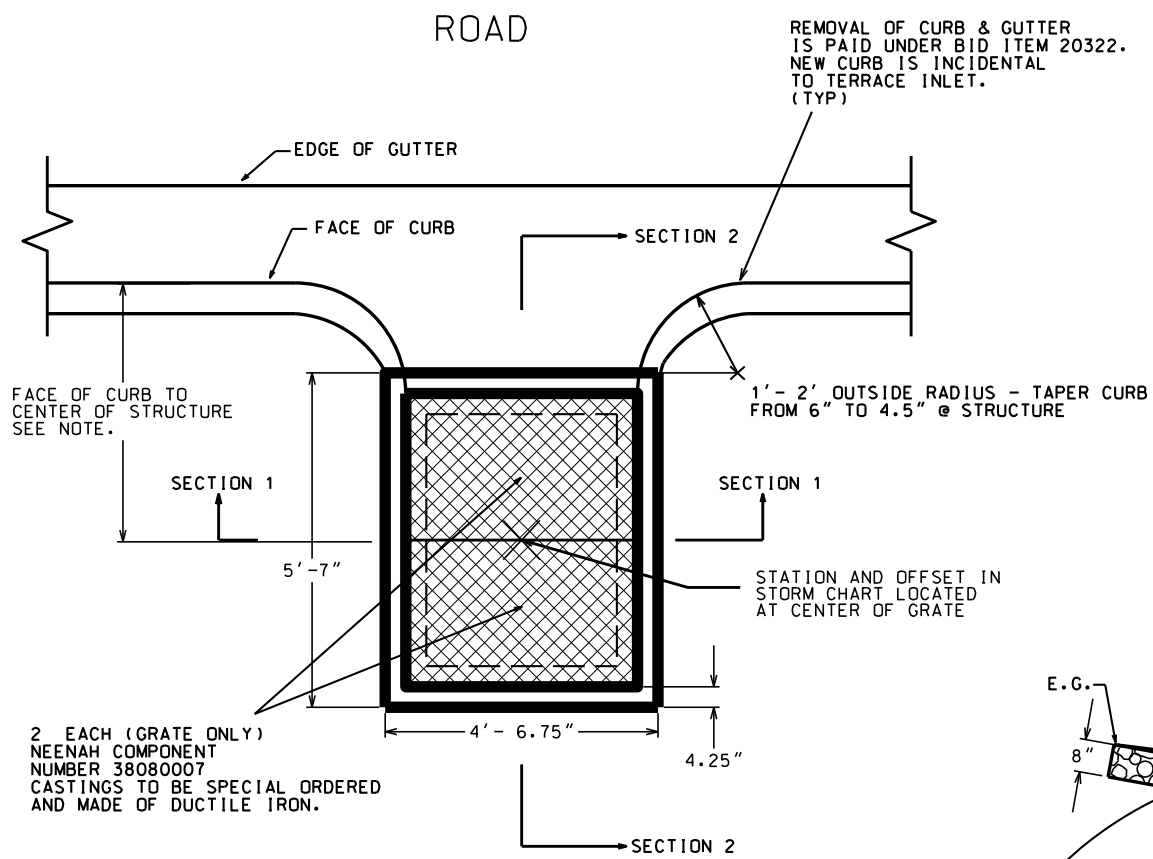

NOTE:  
DIMENSION FROM FACE OF CURB TO CENTER OF STRUCTURE

CURB TYPE	DISTANCE
TYPE A. D. G. X	4'-4"
TYPE B. E. H	4'-10"

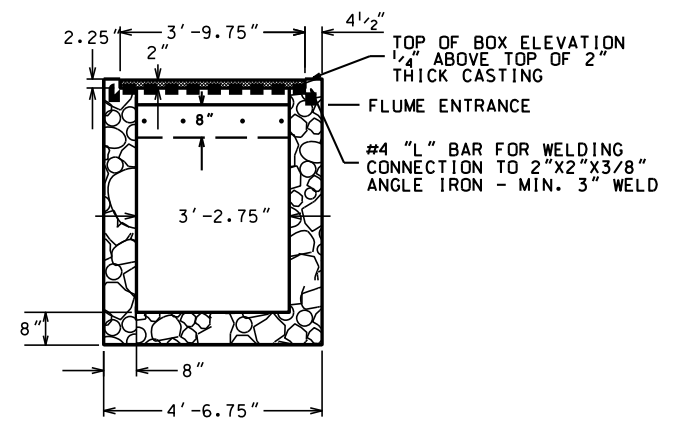

**SECTION 1**

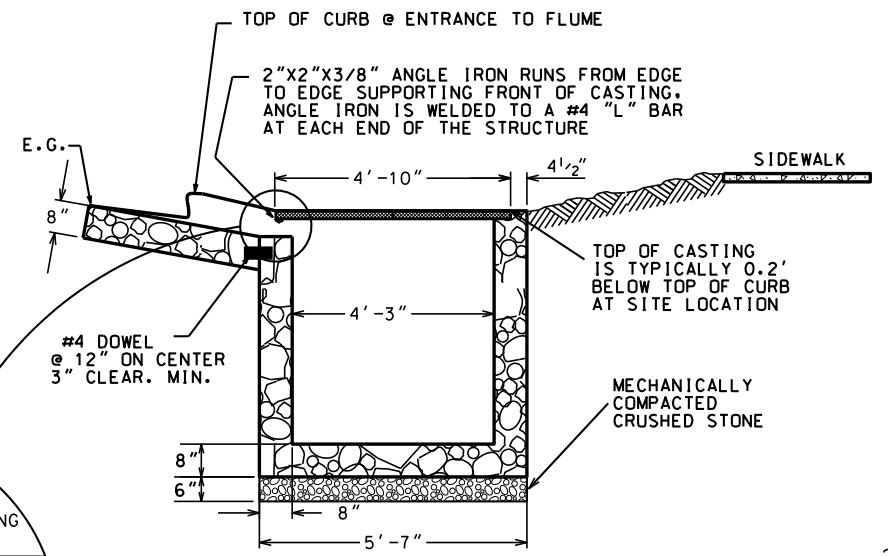

**SECTION 2**

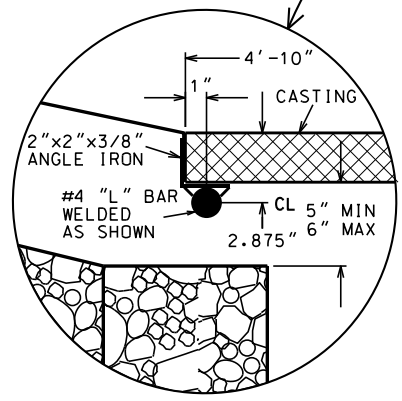

2014

CITY OF MADISON  
ENGINEERING DIVISION

**TERRACE INLET  
TYPE 1**

STANDARD DETAIL DRAWING 5.7.12

5.7.12A

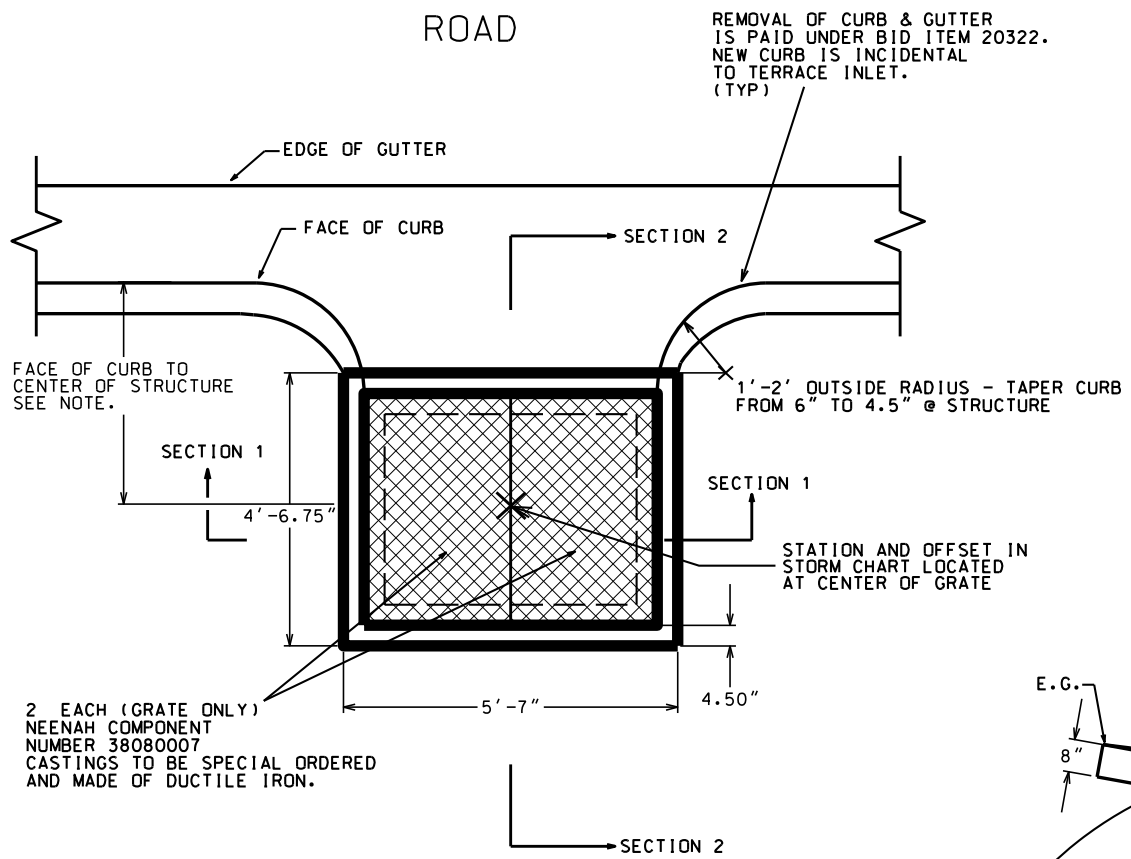

NOTE:  
DIMENSION FROM FACE OF CURB TO CENTER OF STRUCTURE

CURB TYPE	DISTANCE
TYPE A. D. G. X	3'-9"
TYPE B. E. H	4'-3"

REMOVAL OF CURB & GUTTER IS PAID UNDER BID ITEM 20322. NEW CURB IS INCIDENTAL TO TERRACE INLET. (TYP)

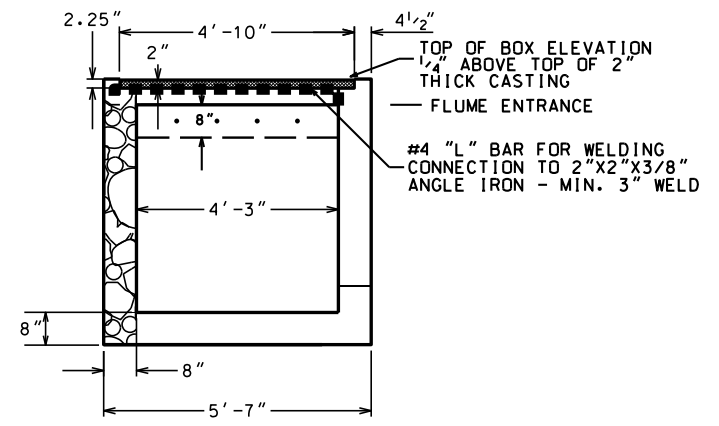

SECTION 1

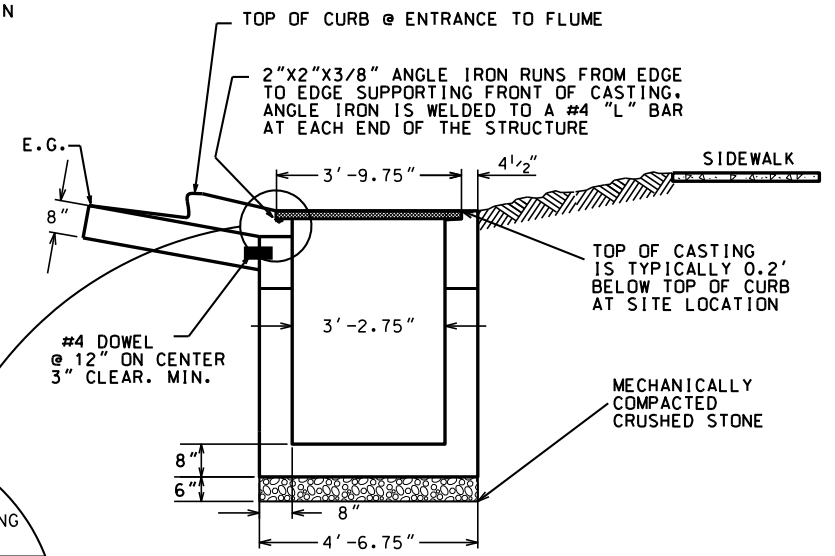

SECTION 2

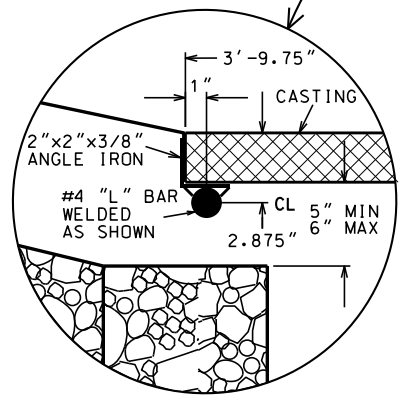

2014

CITY OF MADISON  
ENGINEERING DIVISION

TERRACE INLET  
TYPE 2

STANDARD DETAIL DRAWING 5.7.12A

5.7.12B

ROAD

REMOVAL OF CURB & GUTTER IS PAID UNDER BID ITEM 20322. NEW CURB IS INCIDENTAL TO TERRACE INLET. (TYP)

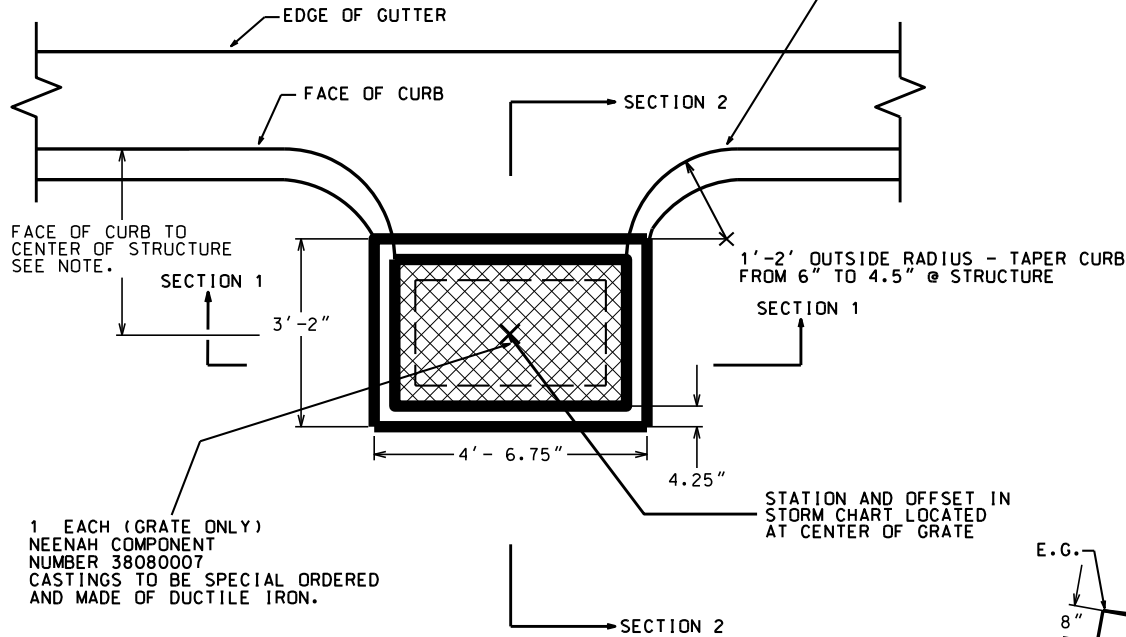

1 EACH (GRATE ONLY)  
NEENAH COMPONENT  
NUMBER 38080007  
CASTINGS TO BE SPECIAL ORDERED  
AND MADE OF DUCTILE IRON.

STRUCTURE  
**PLAN VIEW**

NOTE: DIMENSION FROM FACE OF CURB TO CENTER OF STRUCTURE	
CURB TYPE	DISTANCE
TYPE A. D. G. X	3'-0"
TYPE B. E. H	3'-6"

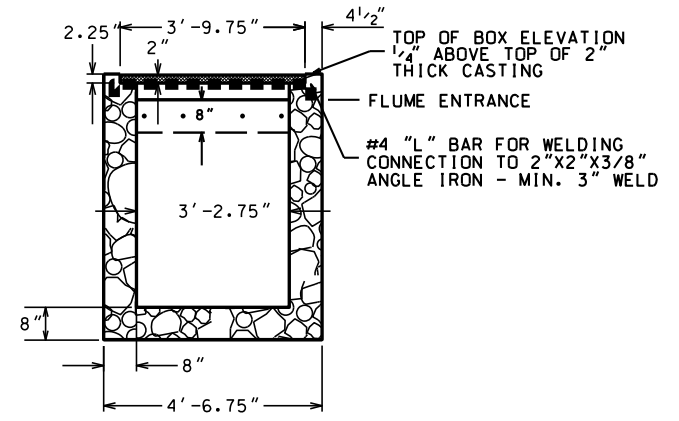

**SECTION 1**

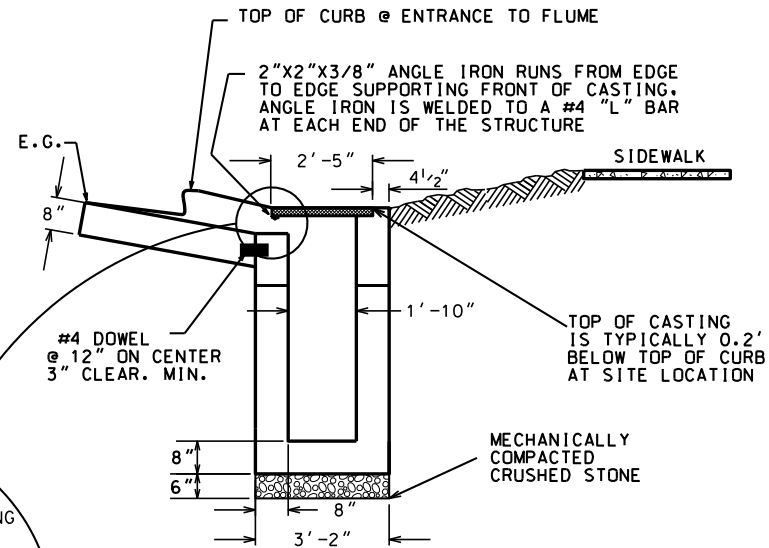

**SECTION 2**

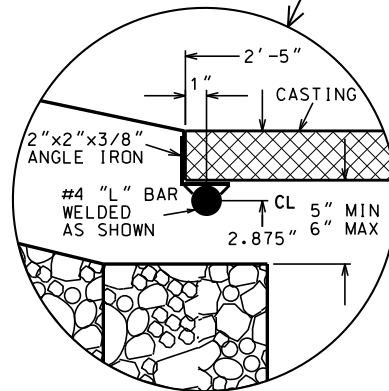

2014

CITY OF MADISON  
ENGINEERING DIVISION

TERRACE INLET  
TYPE 3

STANDARD DETAIL DRAWING 5.7.12B

5.7.12C

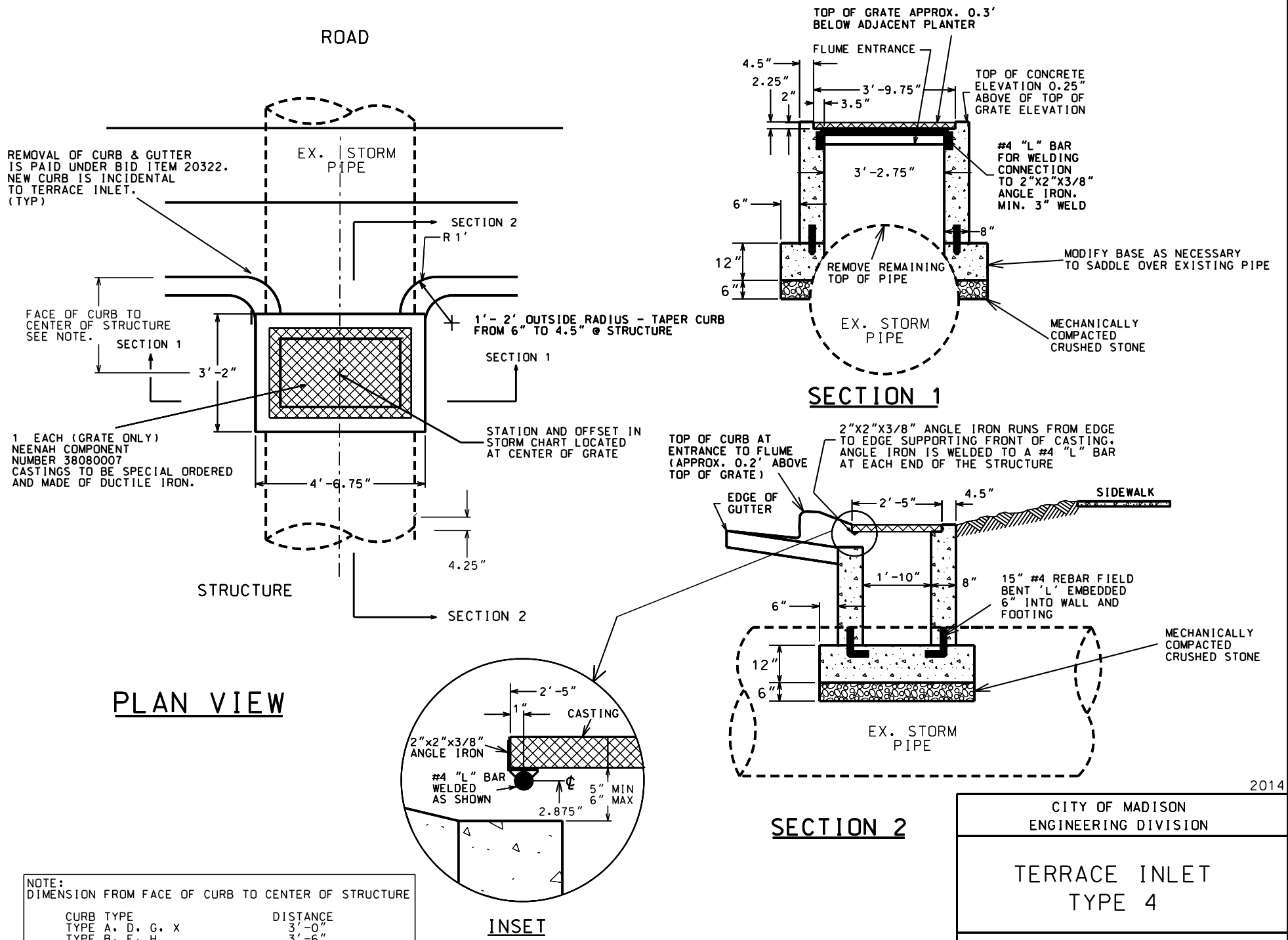

NOTE:  
DIMENSION FROM FACE OF CURB TO CENTER OF STRUCTURE

CURB TYPE	DISTANCE
TYPE A, D, G, X	3'-0"
TYPE B, E, H	3'-6"

2014

CITY OF MADISON  
ENGINEERING DIVISION

---

TERRACE INLET  
TYPE 4

---

STANDARD DETAIL DRAWING 5.7.12C

ROAD

REMOVAL OF CURB & GUTTER IS PAID UNDER BID ITEM 20322. NEW CURB IS INCIDENTAL TO TERRACE INLET. (TYP)

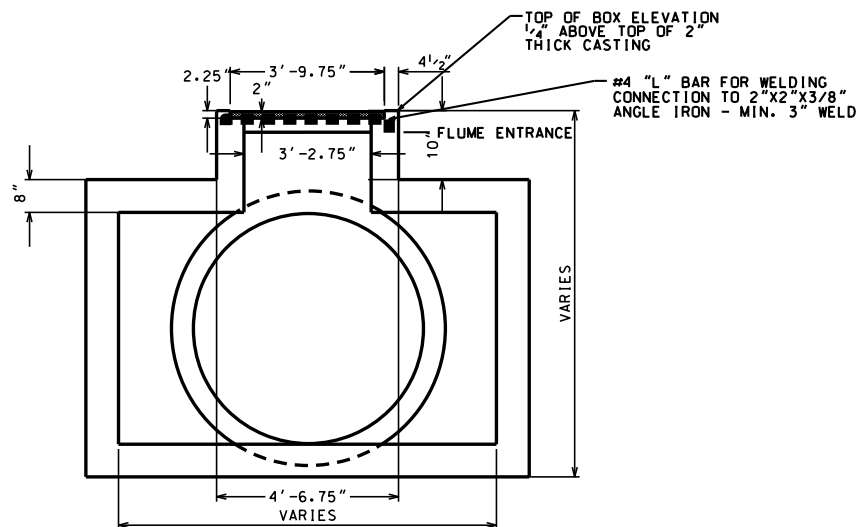
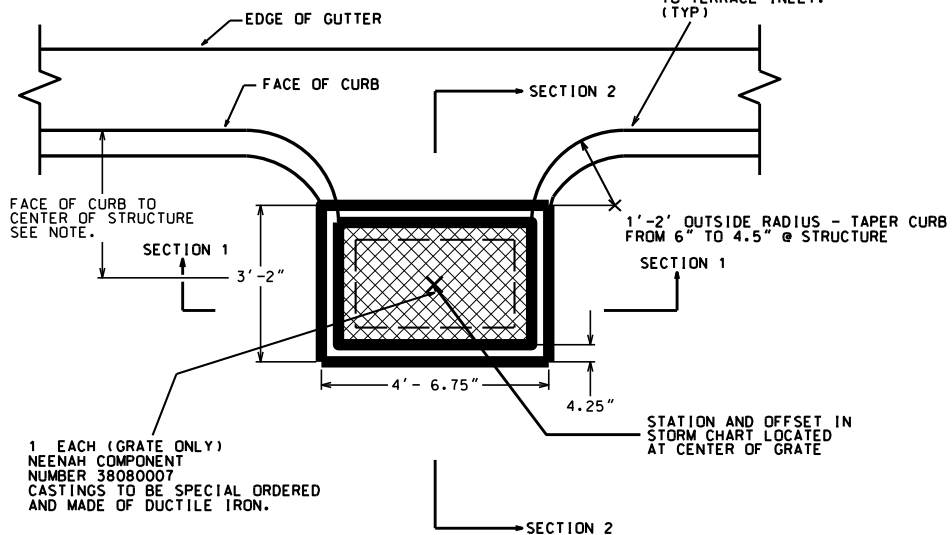

STRUCTURE

PLAN VIEW

SECTION 1

NOTE: DIMENSION FROM FACE OF CURB TO CENTER OF STRUCTURE

CURB TYPE	DISTANCE
TYPE A. D. G. X	3'-0"
TYPE B. E. H	3'-6"

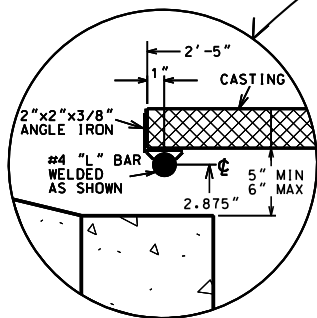
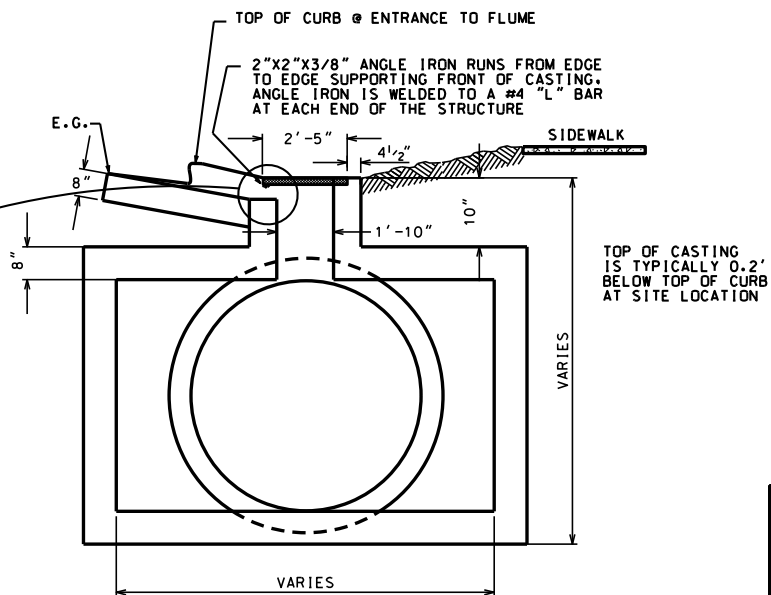

SECTION 2

2014

CITY OF MADISON  
ENGINEERING DIVISION

TERRACE INLET  
TYPE 5

STANDARD DETAIL DRAWING 5.7.12D

5.7.12D

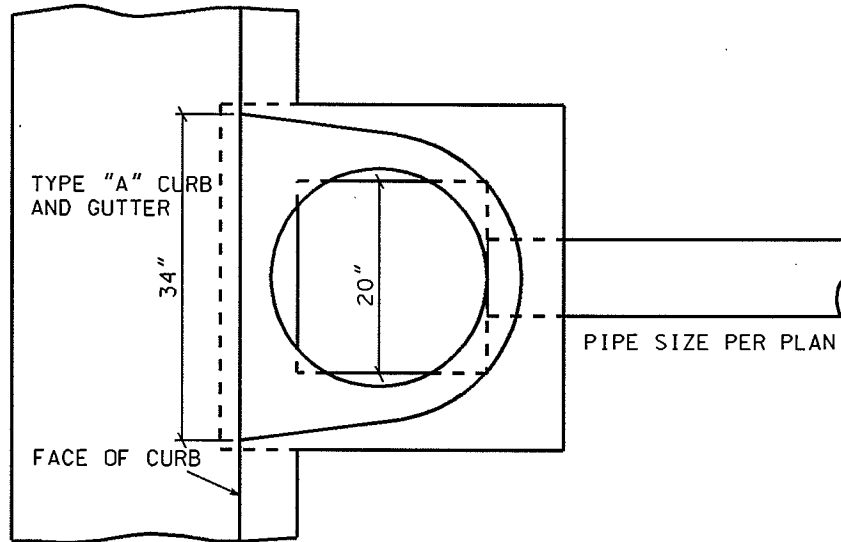

TOP VIEW

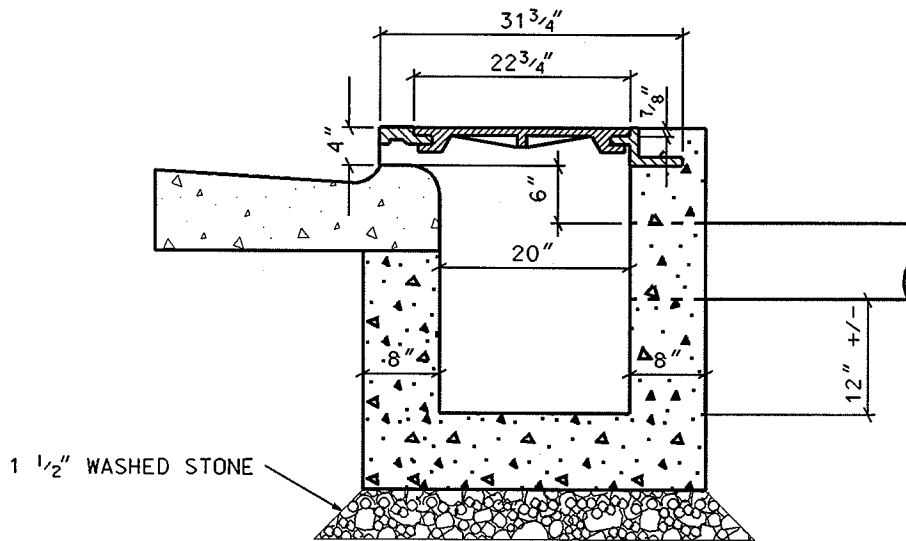

SIDE VIEW

NOTES:

- 1) TYPICAL LOCATION FOR INCOMING PIPE SHOWN. ALTERNATE INCOMING LOCATIONS FROM EITHER SIDE
- 2) CURB OUTLET STRUCTURE FRAME AND LID ARE NEENAH CASTING R-3331
- 3) MAY SUBSTITUTE PRECAST, ROUND CONCRETE STRUCTURE FOR THE SPECIFIED BOX STRUCTURE, WITH A FIELD POURED CONCRETE FLOOR.

2004

CITY OF MADISON  
ENGINEERING DIVISION

CURB OUTLET  
STRUCTURE

STANDARD DETAIL DRAWING 5.7.13

NOTE:  
ATTACHMENT TO REAR OF INLET IS  
SATISFACTORY IF PIPE SIZE RESTRICTS  
SPACE FOR UNDERDRAIN CORE.

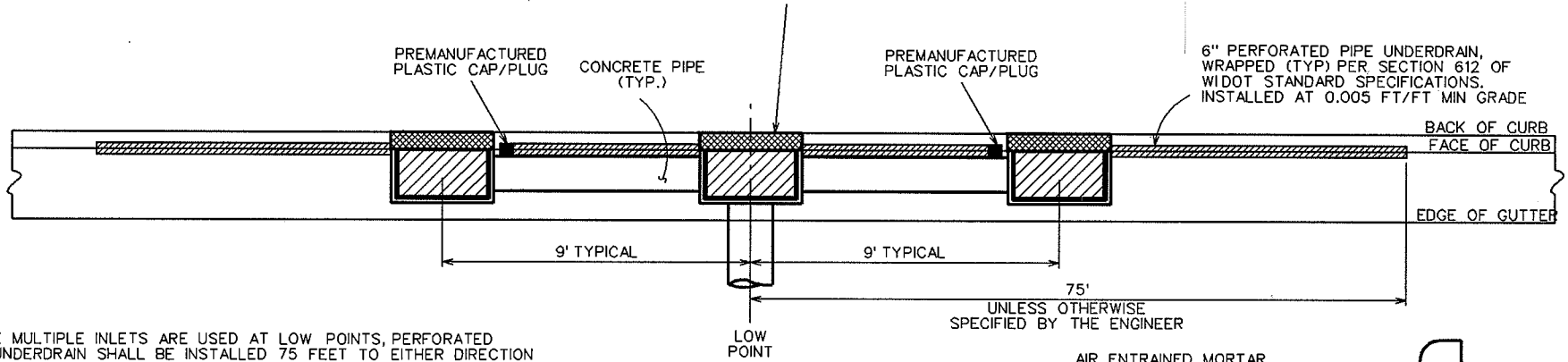

NOTE:  
WHERE MULTIPLE INLETS ARE USED AT LOW POINTS, PERFORATED  
PIPE UNDERDRAIN SHALL BE INSTALLED 75 FEET TO EITHER DIRECTION  
FROM THE LOW POINT AT A MINIMUM POSITIVE GRADE OF 0.005 FT/FT.  
THE SECTION OF UNDERDRAIN BETWEEN THE CENTER AND OUTER INLETS  
SHALL BE PLACED TIGHT TO THE OUTER INLET, CAPPED WITH A  
PREMANUFACTURED PLASTIC CAP OR PLUG, AND LAID AS SPECIFIED ABOVE  
TO THE CENTER INLET.

**TOP VIEW**  
TYPICAL TRIPLE INLET  
CONFIGURATION WITH UNDERDRAIN

UNLESS OTHERWISE  
SPECIFIED BY THE ENGINEER

AIR ENTRAINED MORTAR  
TYPE M OR S  
ADJUSTING RING

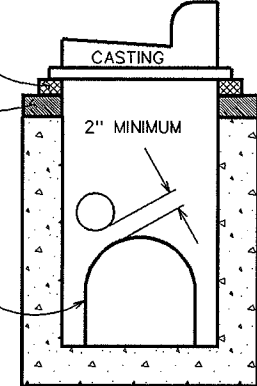

NOTE:  
WHERE 'DOG HOUSES' ARE USED CORE  
HOLES SHALL NOT BE INSTALLED IN THE  
'DOG HOUSE' AND SHALL BE INSTALLED  
2" OUTSIDE THE 'DOG HOUSE'.

**CROSS-SECTION VIEW**  
TYPICAL 'DOG HOUSE'  
INLET CONFIGURATION

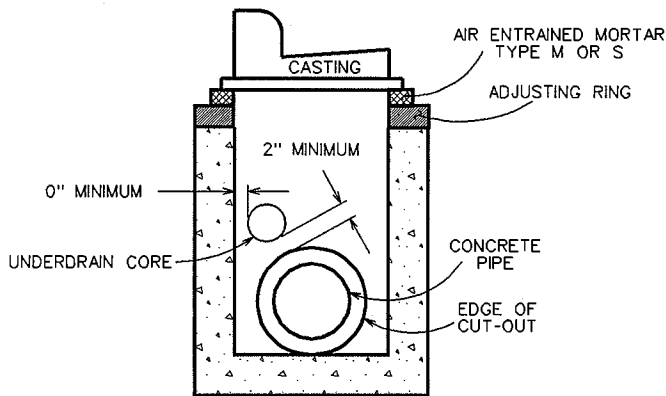

NOTE:  
(1) CORE HOLES SHALL PROVIDE FOR A  
MINIMUM OF 2" OF CONCRETE BETWEEN  
THE CUTOUT FOR A CONCRETE PIPE AND  
THE EDGE OF THE CORE HOLE.  
(2) CORE HOLES MAY HAVE 0" CLEARANCE  
FROM THE INSIDE WALLS OF A STRUCTURE.

**CROSS-SECTION VIEW**  
TYPICAL INLET IN SUMP  
CONDITION WITH  
UNDERDRAIN CORED  
INTO WALL WITH PIPE

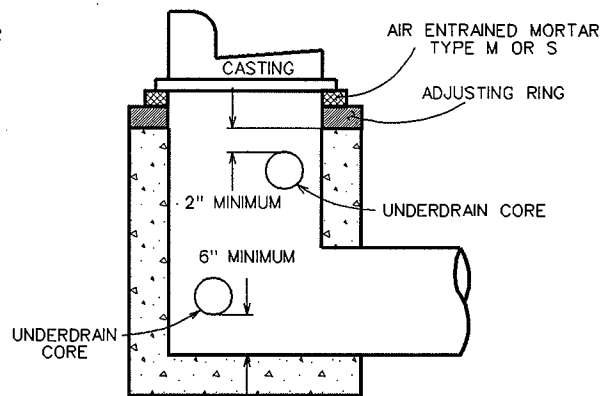

NOTE:  
(1) BOTTOM OF CORE PLACED A MINIMUM  
OF 6" ABOVE THE FLOOR OF THE INLET.  
(2) TOP OF CORE HOLES WILL BE A MINIMUM  
OF 2" BELOW THE TOP OF THE INLET  
STRUCTURES (BOTTOM OF RINGS)  
(3) DRAIN TILES SHALL NOT BE ALLOWED IN  
THE RING OF THE STRUCTURE OF INLETS  
OR SEWER ACCESS STRUCTURES

**CROSS-SECTION VIEW**  
TYPICAL INLET CONFIGURATION  
WITH UNDERDRAIN CORED  
INTO WALL WITH NO PIPE

5.7.14

DRAWING NOT TO SCALE

2004
CITY OF MADISON ENGINEERING DIVISION
<b>UNDERDRAIN</b>
STANDARD DETAIL DRAWING 5.7.14

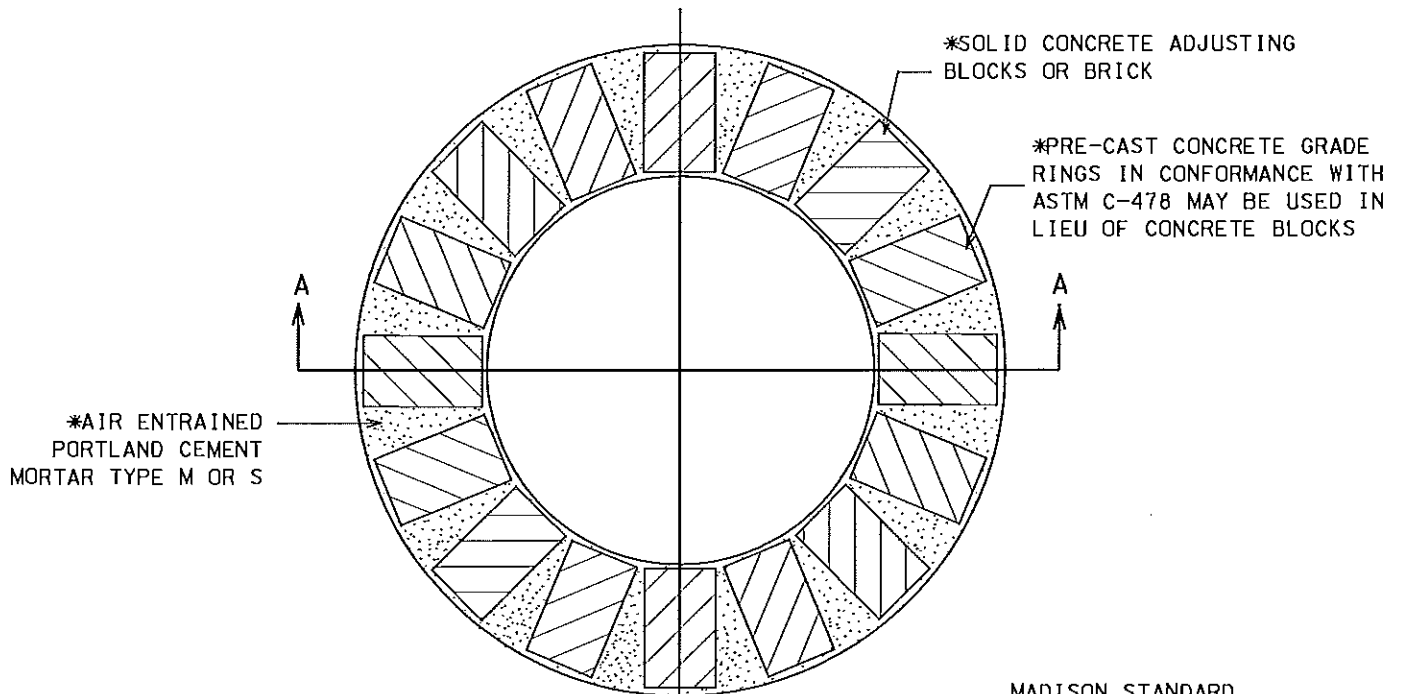

\*SOLID CONCRETE ADJUSTING  
BLOCKS OR BRICK

\*PRE-CAST CONCRETE GRADE  
RINGS IN CONFORMANCE WITH  
ASTM C-478 MAY BE USED IN  
LIEU OF CONCRETE BLOCKS

\*AIR ENTRAINED  
PORTLAND CEMENT  
MORTAR TYPE M OR S

\*THE OUTSIDE OF ADJUSTING  
RINGS SHALL BE SEALED WITH  
A 1/2" THICK, AIR ENTRAINED  
MORTAR TYPE M OR S SEAL.  
THE METHOD USED WILL BE  
COMPATIBLE WITH THE ADJUSTING  
RING JOINT SEALING METHODS.

MADISON STANDARD  
MACHINED CAST IRON  
ACCESS STRUCTURE COVER

\*2" MINIMUM BED OF  
AIR ENTRAINED MORTAR  
TYPE M OR S

\*ALL JOINTS SHALL  
BE SEALED WITH  
3/8" OF AIR ENTRAINED  
MORTAR TYPE M OR S.

MIN. 3" / MAX. 9"  
OF ADJUSTMENTS

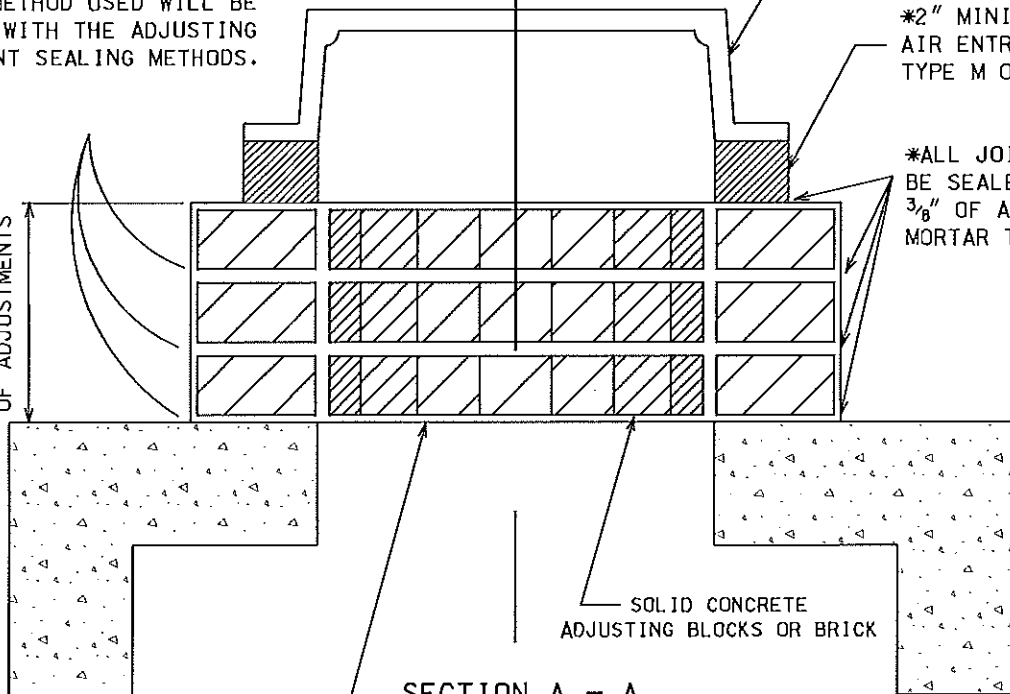

SOLID CONCRETE  
ADJUSTING BLOCKS OR BRICK

SECTION A - A

\*PRE-CAST CONCRETE GRADE  
RINGS IN CONFORMANCE WITH  
ASTM C-478 MAY BE USED IN  
LIEU OF CONCRETE BLOCKS

\*NOTE: RUBBER ADJUSTMENT RINGS (CRETEX PRO-RING OR APPROVED EQUIV.) INSTALLED IN ACCORDANCE WITH MANUFACTURER'S RECOMMENDATIONS WILL BE CONSIDERED AN ACCEPTABLE ALTERNATE TO PRECAST RINGS, IF RUBBER ADJUSTMENT RINGS ARE INSTALLED, THERE WILL BE NO NEED OR PAYMENT FOR AN INTERNAL CHIMNEY SEAL (SDD 5.7.17)

2011

CITY OF MADISON  
ENGINEERING DIVISION

SAS CHIMNEY  
AND CASTING

STANDARD DETAIL DRAWING 5.7.15



5.7.16

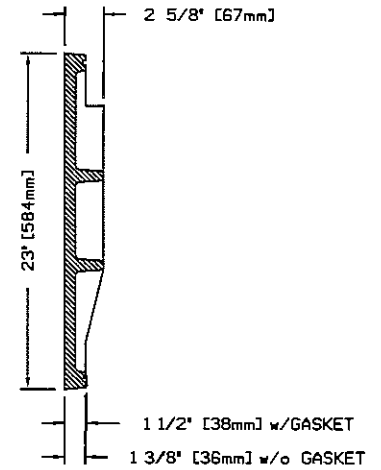
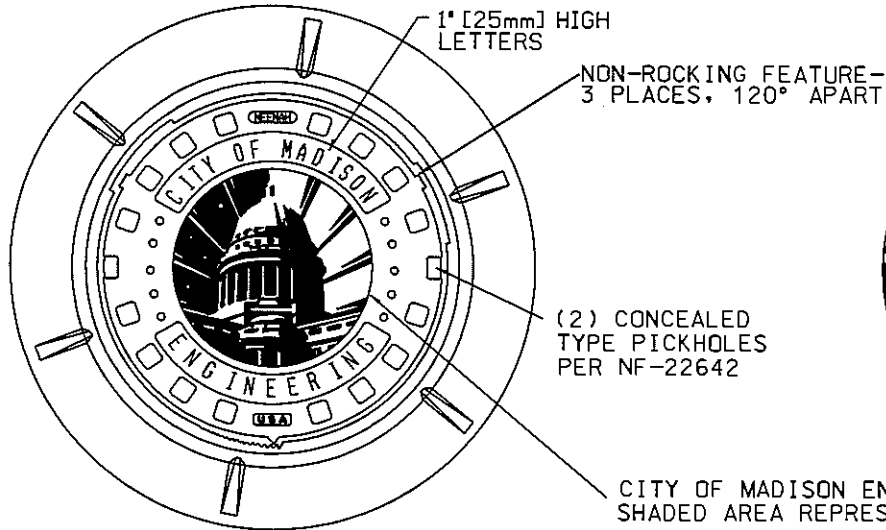

CITY OF MADISON ENGINEERING LOGO,  
SHADED AREA REPRESENTS RECESSED AREA

NOTES:

APPROXIMATE TOTAL WEIGHTS:  
R-1550 w/ LOGO LID 1550-0054, 9" FRAME AND LID = 265 LBS.  
R-1689 w/ LOGO LID 1550-0054, 4" FRAME AND LID = 279 LBS.

IF LOCKABLE LID IS NECESSARY, R-1920, 83/4" FRAME AND LID = 300 LBS  
THERE IS NO CITY OF MADISON LOGO LID AVAILABLE FOR THIS  
FRAME AND CASTING.

THE FOLLOWING NEENAH FOUNDRY CASTINGS (OR EQUAL CASTINGS)  
SHALL BE ACCEPTABLE:

1. R-1550, 9" NON-ROCKING ACCESS STRUCTURE FRAME.
2. R-1689, 4" NON-ROCKING ACCESS STRUCTURE FRAME  
(WHEN REQUESTED BY THE CITY CONSTRUCTION ENGINEER).
3. R-1920, 83/4" ACCESS STRUCTURE FRAME WITH LOCKING LID,  
TYPE 'F' LOCKS, AND CONCEALED PICK HOLES. TO BE USED IN  
GREENWAYS AND EASEMENTS.

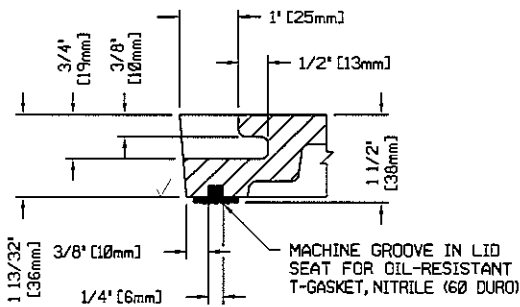
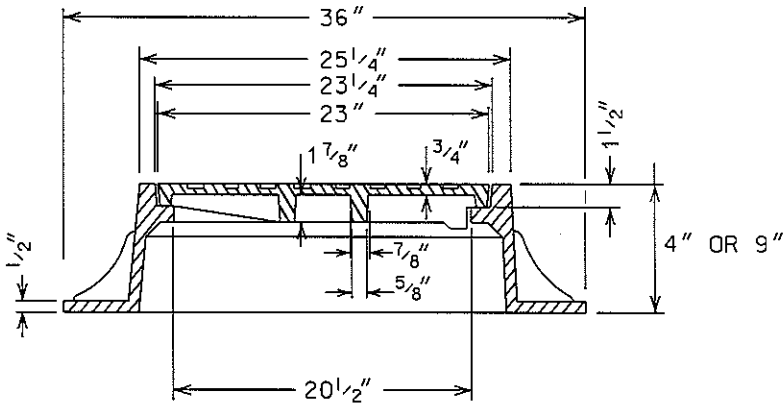

T-SEAL GASKET / CONCEALED PICK DETAIL

1. FRAME AND COVER SHALL BE MACHINED AND  
FITTED SO THAT ROCKING AND CHATTERING  
WILL BE ELIMINATED.
2. ALL LIDS SHALL BE SELF-SEALING EXCEPT  
FOR STORM SEWER.
3. ALL LIDS SHALL HAVE CITY OF MADISON LOGO  
AS SHOWN IN DETAIL (R-1550-0054 OR EQUIV.)

LID NOTES: ALL DIMENSIONS SHOWN ARE IN ENGLISH AND [METRIC]  
MATERIAL: CAST GRAY IRON ASTM A-48, CLASS 35B

2006

CITY OF MADISON  
ENGINEERING DIVISION

SAS FRAME & COVER

STANDARD DETAIL DRAWING 5.7.16

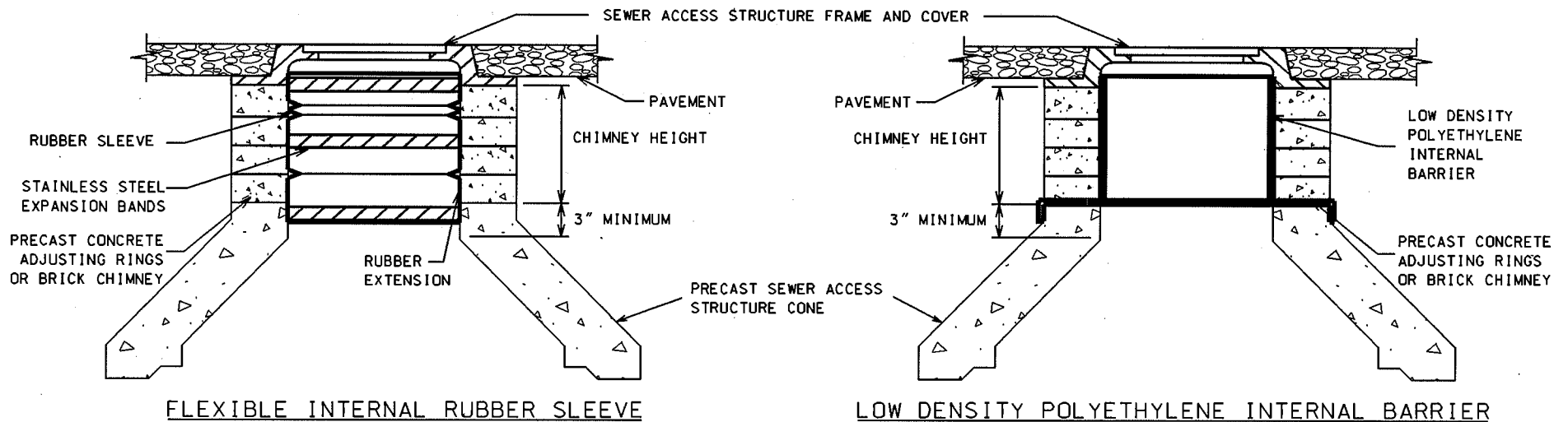

FLEXIBLE INTERNAL RUBBER SLEEVE

LOW DENSITY POLYETHYLENE INTERNAL BARRIER

AN INTERNAL CHIMNEY SEAL WHERE NEEDED, SHALL BE INSTALLED TO COVER THE ENTIRE CHIMNEY AREA IN ACCORDANCE WITH THE MANUFACTURER'S INSTRUCTIONS. FRAME SEALS SHALL CONSIST OF ONE OF THE FOLLOWING TYPES OF INTERNAL SEALS:

1) FLEXIBLE INTERNAL RUBBER SLEEVE

A FLEXIBLE INTERNAL RUBBER SLEEVE, INTERLOCKING EXTENSIONS AND STAINLESS STEEL EXPANSION BANDS AS MANUFACTURED BY CRETEX SPECIALTY PRODUCTS OR AN APPROVED EQUAL CONFORMING TO THE FOLLOWING REQUIREMENTS.

THE SEAL SHALL REMAIN FLEXIBLE THROUGHOUT A 25 YEAR DESIGN LIFE, ALLOWING REPEATED VERTICAL MOVEMENT OF THE FRAME OF NOT LESS THAN 2 INCHES AND/OR REPEATED HORIZONTAL MOVEMENTS OF NOT LESS THAN 1/2 INCH. THE SLEEVE PORTION OF THE SEAL SHALL BE EITHER DOUBLE OR TRIPLE PLEATED WITH A MINIMUM UNEXPANDED VERTICAL HEIGHT OF EITHER 8 INCHES OR 10 INCHES, RESPECTIVELY. THE SLEEVE AND EXTENSION SHALL HAVE A MINIMUM THICKNESS OF 3/16 INCHES AND SHALL BE MADE FROM A HIGH QUALITY RUBBER COMPOUND CONFORMING TO THE APPLICABLE REQUIREMENTS OF ASTM C-923, WITH A MINIMUM 1500 PSI TENSILE STRENGTH, A MAXIMUM 18% COMPRESSION SET AND A HARDNESS (DUROMETER) OF 48 +/- . THE BANDS SHALL BE FABRICATED FROM 16 GAUGE STAINLESS STEEL CONFORMING TO ASTM A-240, TYPE 304 AND SHALL HAVE A MINIMUM ADJUSTMENT RANGE OF 2 DIAMETER INCHES AND A POSITIVE LOCKING MECHANISM. ANY SCREWS, BOLTS OR NUTS USED FOR THIS MECHANISM SHALL BE STAINLESS STEEL CONFORMING TO ASTM F-593 AND 594, TYPE 304.

2) LOW DENISTY POLYETHYLENE INTERNAL BARRIER

A LOW DENSITY POLYETHYLENE INTERNAL BARRIER SHALL MAINTAIN THEIR ADHESION ALLOWING REPEATED HORIZONTAL MOVEMENT OF NOT LESS THAN 1 INCH. THE BARRIER SHALL HAVE A MINIMUM THICKNESS OF 1/4 INCH AND CONFORM TO THE REQUIREMENTS OF THE FOLLOWING STANDARDS:  
ASTM D 790/1505, D 1238, D 638, D 790, D 648 AND D 1693.

INTERNAL CHIMNEY SEALS SHALL BE USED ON ALL SANITARY SEWER ACCESS STRUCTURES AT THE FOLLOWING LOCATIONS:

- 1) WITHIN 100' OF A STREET LOW POINT
- 2) ALL GREENWAYS
- 3) WHERE SPECIFIED BY THE ENGINEER

2004

CITY OF MADISON  
ENGINEERING DIVISION

SAS INTERNAL  
CHIMNEY SEAL

STANDARD DETAIL DRAWING 5.7.17

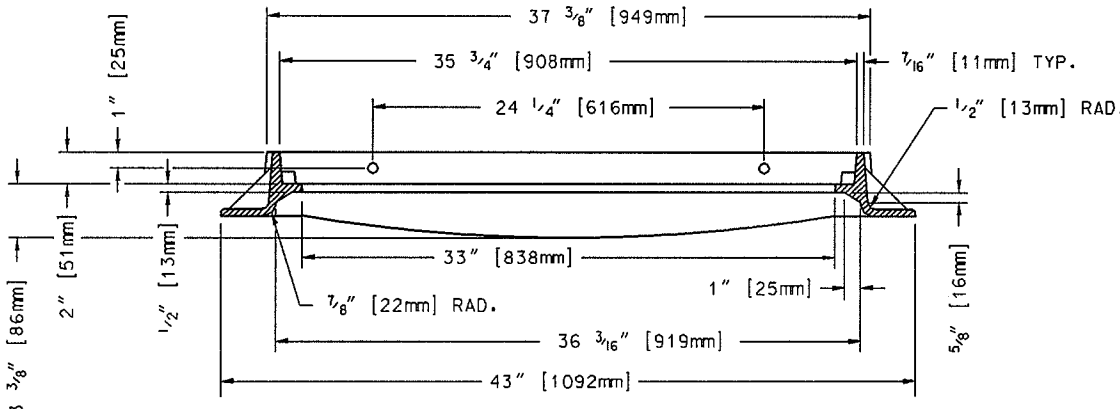
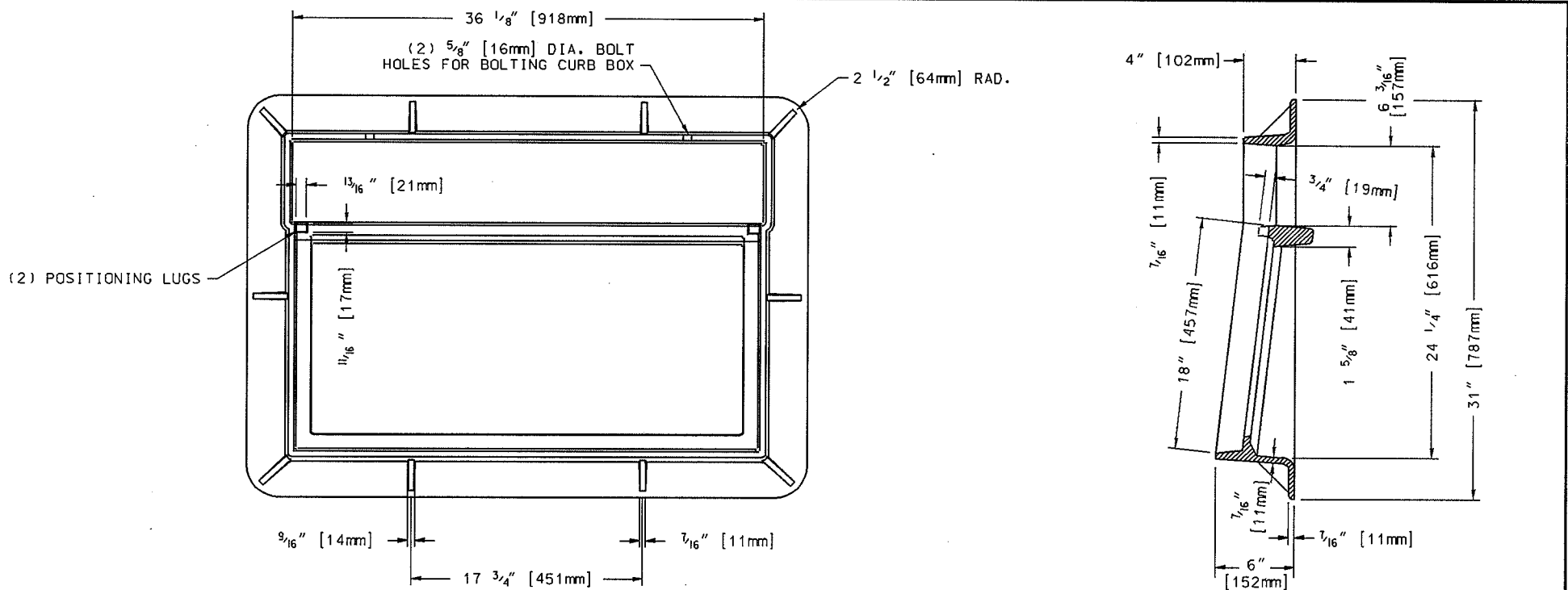

NOTES: ALL DIMENSIONS ARE SHOWN IN ENGLISH AND [METRIC].  
 ALL DRAFT ANGLES ARE 5° UNLESS OTHERWISE SHOWN.  
 MATERIAL: CAST GRAY IRON ASTM A-48, CLASS 35B  
 FINISH: NOT PAINTED  
 WEIGHT: APPROX. 207#

NEENAH FOUNDRY CASTINGS

1. R-3067 CURB INLET FRAME WITH DIAGONAL GRATE (TYPE R) SHALL BE USED FOR TYPE "H" INLETS AT ALL LOW POINTS AND WHERE LONGITUDINAL ROAD SLOPE IS LESS THAN 1%. GRATE PER STANDARD DETAIL DRAWING 5.7.20
2. R-3067-V CURB INLET FRAME WITH VANE GRATE (TYPE V) SHALL BE USED FOR "H" INLETS AT ALL LOCATIONS HAVING A LONGITUDINAL ROAD SLOPE EQUAL TO OR GREATER THAN 1%. GRATE PER STANDARD DETAIL DRAWING 5.7.21

NOTE: ALL DIMENSIONS ARE SHOWN IN ENGLISH AND [METRIC].

GENERAL NOTES:

1. DETAILS OF CONSTRUCTION, MATERIALS, AND WORKMANSHIP NOT SHOWN ON THIS DRAWING SHALL CONFORM TO THE PERTINENT REQUIREMENTS OF THE STANDARD SPECIFICATIONS AND THE APPLICABLE SPECIAL PROVISIONS.
2. DETAIL DRAWINGS FOR PROPOSED ALTERNATE DESIGNS FOR INLET COVERS SHALL BE SUBMITTED TO THE ENGINEER FOR APPROVAL PROVIDING THAT SUCH ALTERNATE DESIGNS MAKE PROVISION FOR EQUIVALENT CAPACITY AND STRENGTH.
3. ROUND FRAMES AND COVERS SHALL HAVE CONTINUOUSLY MACHINED BALL BEARING SURFACES TO PREVENT ROCKING AND RATTLING.
4. ACTUAL WEIGHT OF COVERS MAY VARY WITHIN 5 PERCENT (PLUS OR MINUS) OF THE APPROXIMATE WEIGHT.
5. INLETS SHALL BE DEPRESSED IN THE CURB FLOW LINE, SEE MADISON STANDARD DETAIL DRAWING 5.7.7

2004
CITY OF MADISON ENGINEERING DIVISION
<b>R-3067 FRAME</b>
STANDARD DETAIL DRAWING 5.7.18

5.7.20

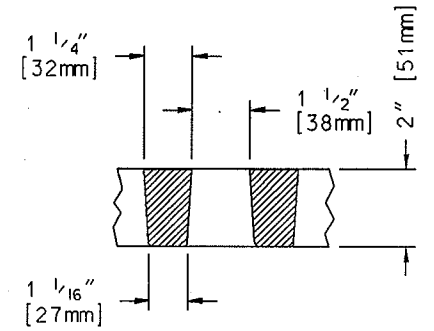
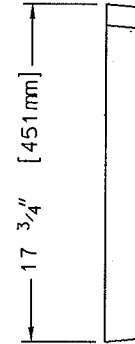
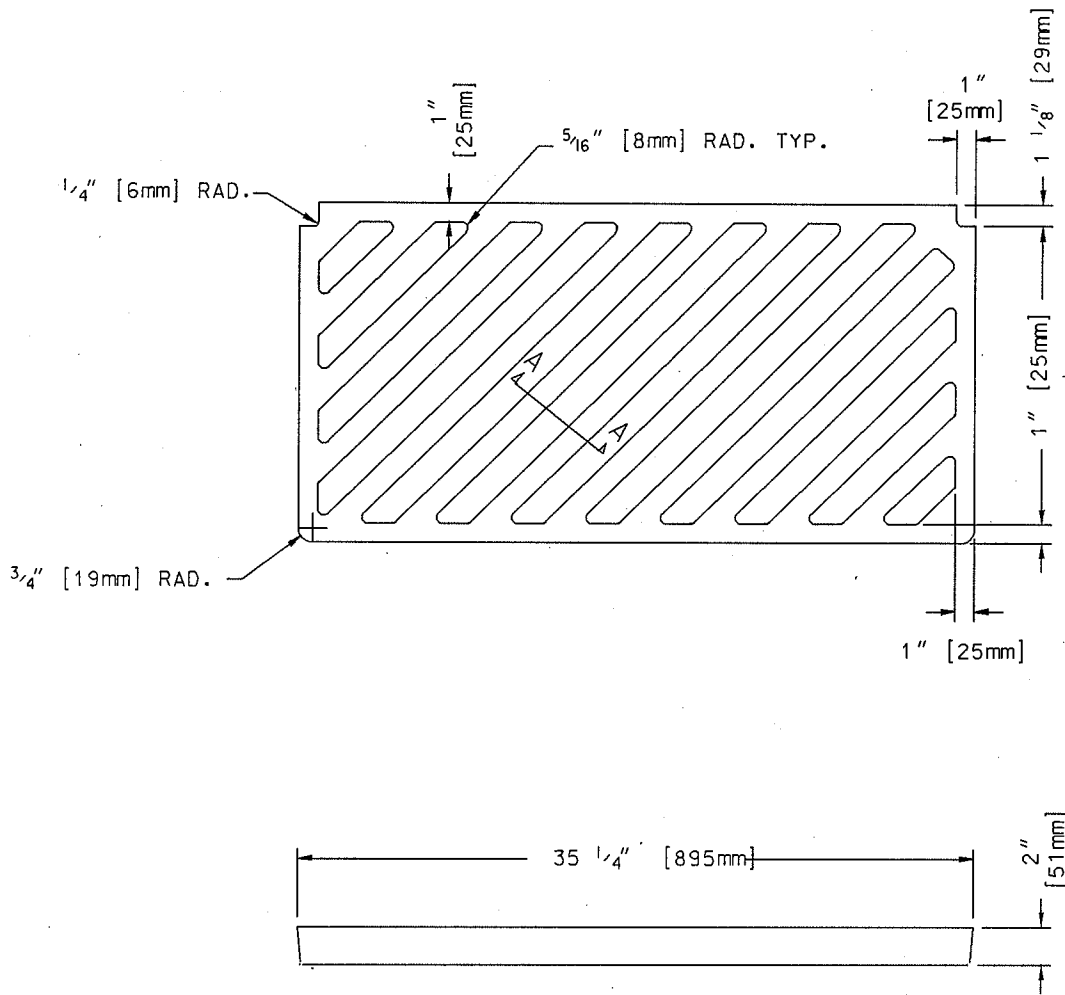

SECTION A-A

FREE OPEN AREA: 282 SQUARE INCHES  
 NOTE: ALL DIMENSIONS ARE SHOWN IN ENGLISH AND [METRIC].  
 MATERIAL: CAST GRAY IRON ASTM A-48, CLASS 35B  
 FINISH: NO PAINT  
 WEIGHT: 172#

2004

CITY OF MADISON ENGINEERING DIVISION
<b>R-3067 TYPE R GRATE</b>
STANDARD DETAIL DRAWING 5.7.20

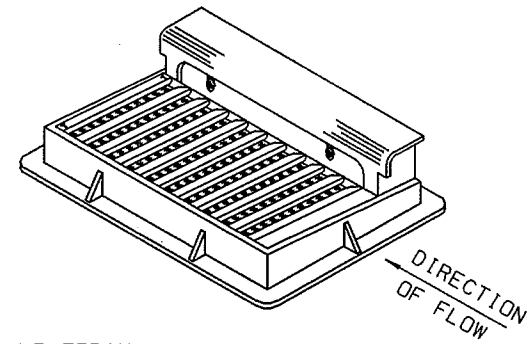
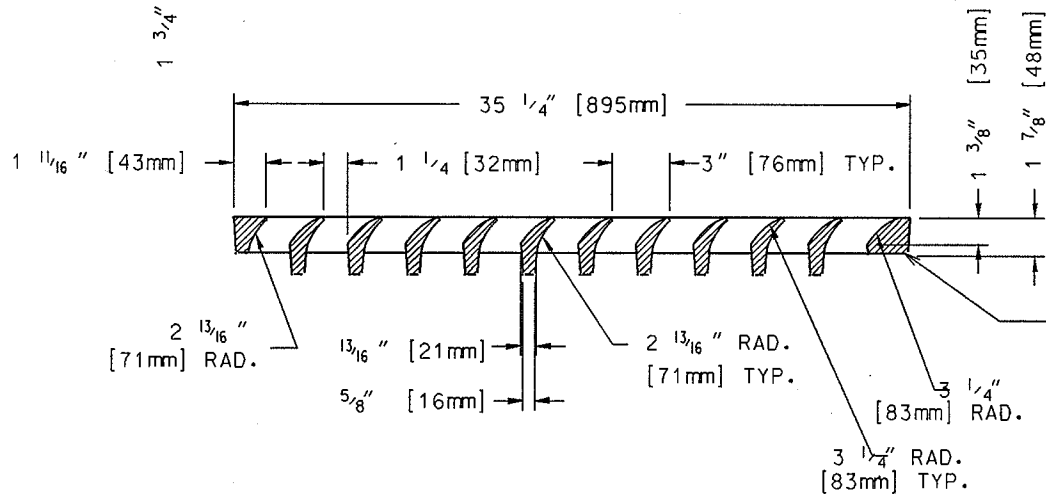
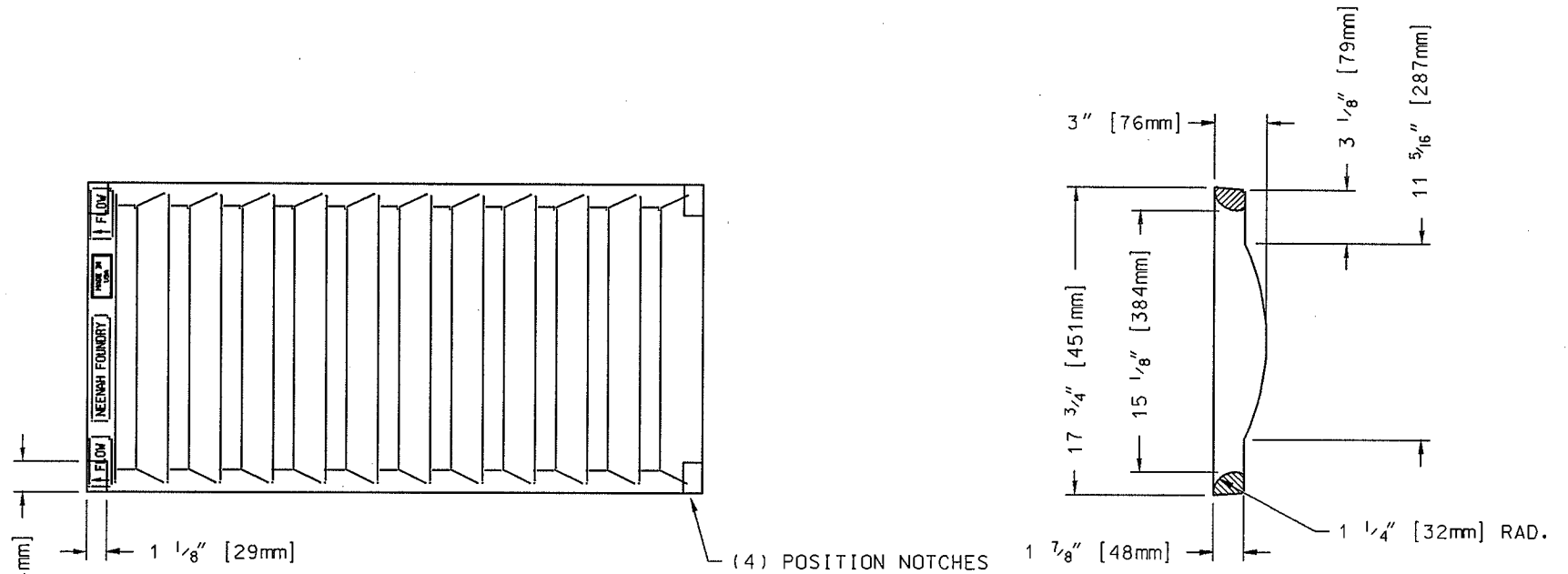

RECESSED LETTERING:  
COMPONENT NO. AND  
HEAT DATE

FREE OPEN AREA = 347 SQUARE INCHES  
MATERIAL: CAST GRAY IRON ASTM A-48, CLASS 35B  
FINISH: NO PAINT  
WEIGHT: 132#

NOTE: GRATE IS REVERSIBLE. R-3067-V  
(LEFT FLOW) IS SHOWN IN DETAILS

2004

CITY OF MADISON ENGINEERING DIVISION
<b>R-3067</b> <b>TYPE V GRATE (VANE)</b>
STANDARD DETAIL DRAWING 5.7.21

TYPE "C" CHECKERED TOP DESIGN

3/4" HIGH RAISED LETTERS  
FLUSH W/ TOP SURFACE

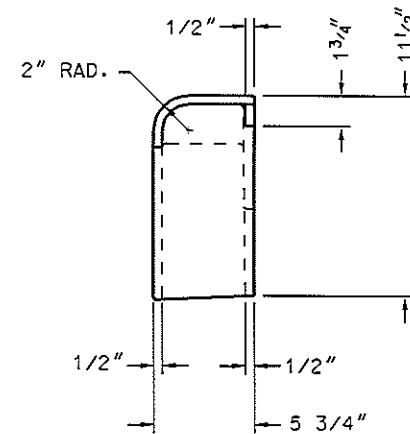
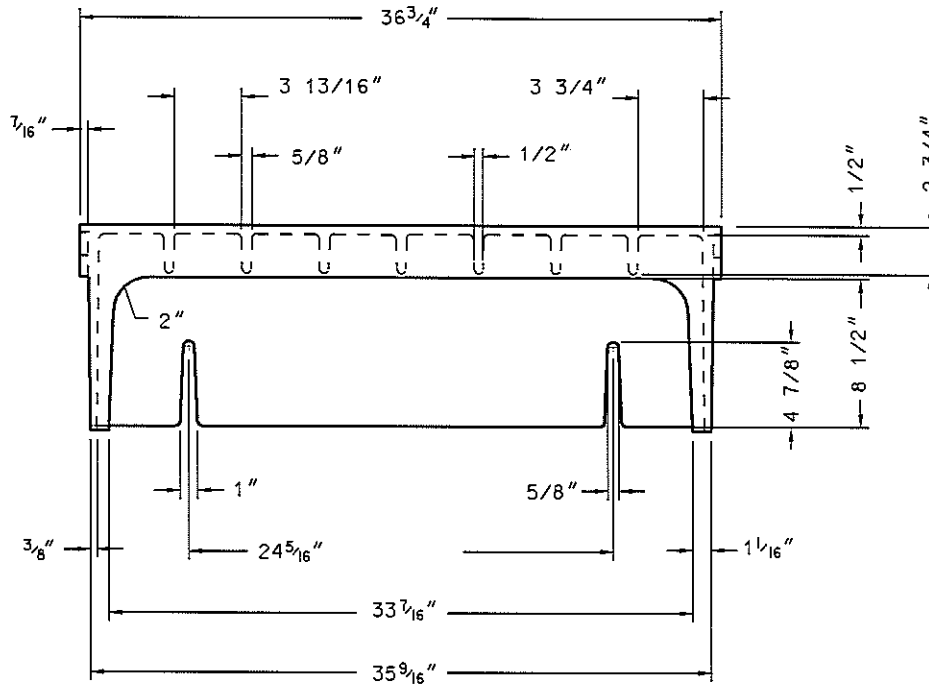
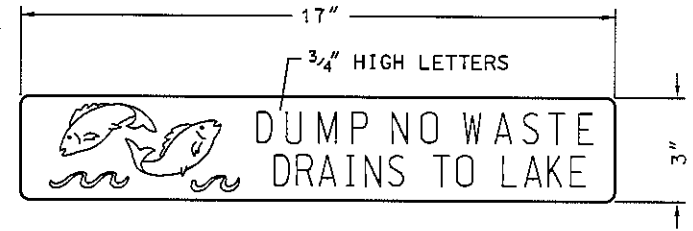

5.7.22

NEENAH FOUNDRY PRODUCT NUMBER 3067 7004  
MATERIAL: CAST GRAY IRON ASTM A-48, CLASS 35B  
FINISH: NO PAINT  
WEIGHT: 126#

2006
CITY OF MADISON ENGINEERING DIVISION
R-3067-7004
STANDARD DETAIL DRAWING 5.7.22

5.7.24

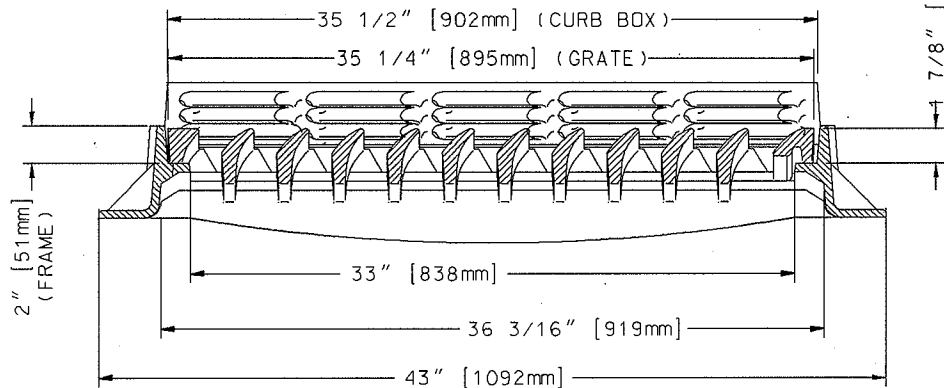
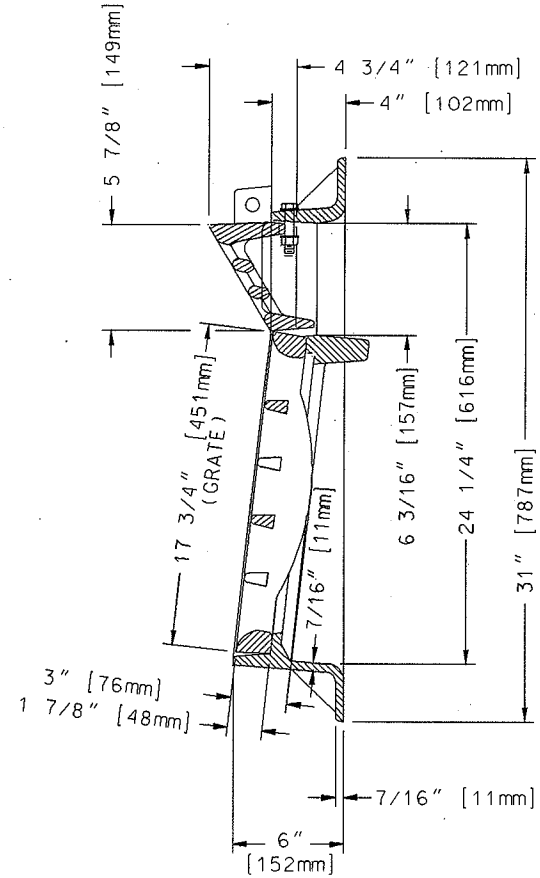
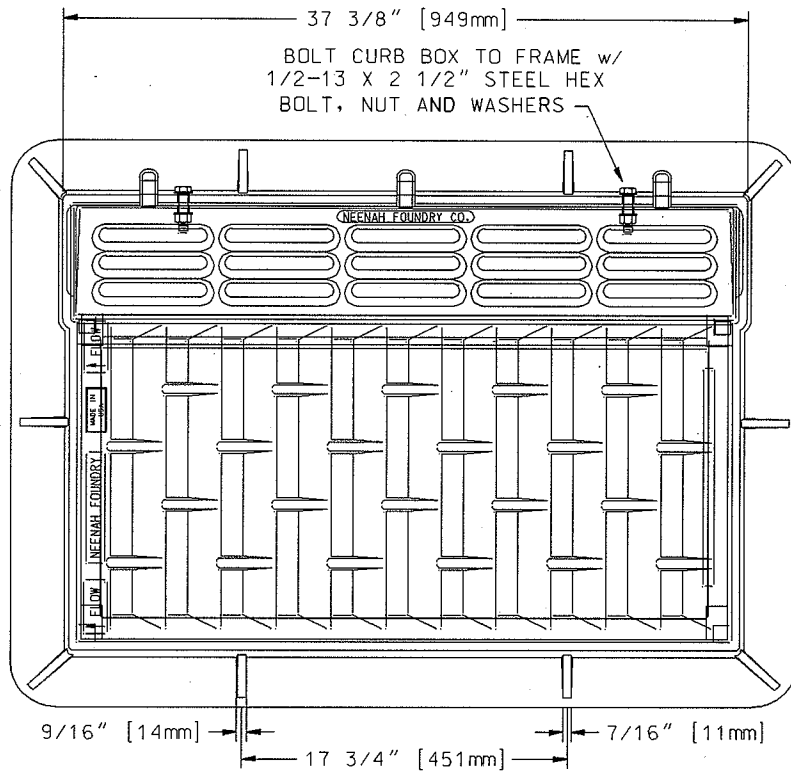

SHOWN WITH TYPE L GRATE (STAGGERED VANE).  
 SPECIFIED AS R-3067-L-CDS. OMIT "L" FOR TYPE R GRATE.

NOTE: ALL DIMENSIONS SHOWN ARE IN ENGLISH AND [METRIC].  
 COMPONENT NO'S: FRAME 3067-2000; GRATE 3067-3000; CURB BOX 3067-7001  
 MATERIAL: CAST GRAY IRON ASTM A-48, CLASS 35B  
 FINISH: NO PAINT  
 WEIGHT: FRAME 184#; GRATE 131#; CURB BOX 68#

2004

CITY OF MADISON ENGINEERING DIVISION
<b>R-3067 CDS CURB BOX</b>
STANDARD DETAIL DRAWING 5.7.24

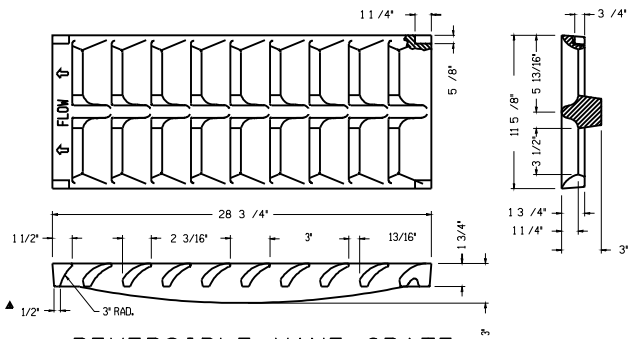

REVERSIBLE VANE GRATE  
FOR TYPE "S" INLET  
(R-3281-AL OR -AR)

APPROXIMATE WEIGHT = 96 LBS.

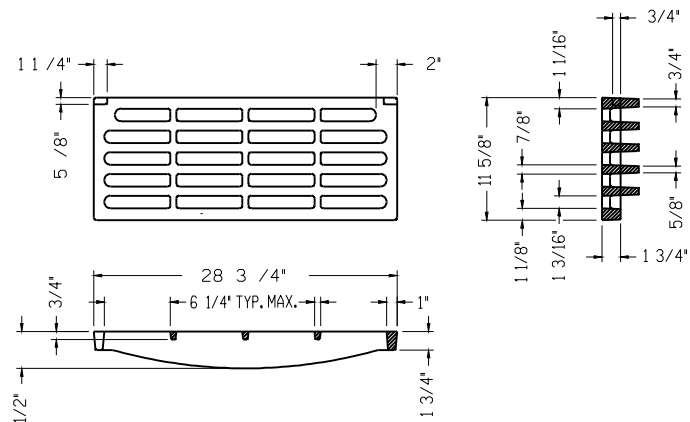

TYPE 'C' GRATE  
FOR TYPE "S" INLET  
(R-3281-A)

APPROXIMATE WEIGHT = 107 LBS.

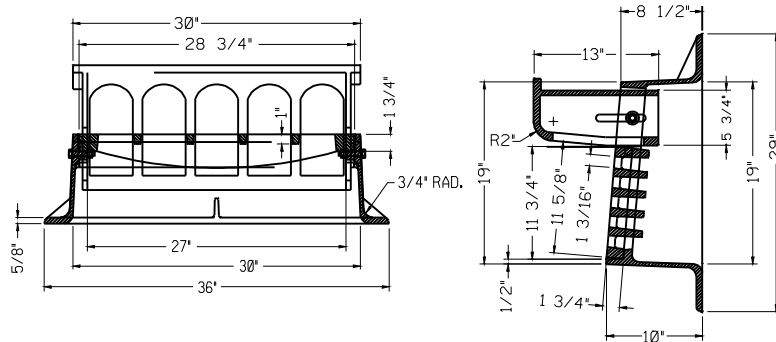

NEENAH FOUNDRY CASTINGS

1. CURB INLET FRAME R-3281-A WITH TYPE 'C' GRATE SHALL BE USED FOR TYPE "S" INLETS AT ALL LOW POINTS AND WHERE LONGITUDINAL ROAD SLOPE IS LESS THAN 1%.
2. CURB INLET FRAME R-3281-AL WITH TYPE 'L' GRATE SHALL BE USED FOR TYPE "S" INLETS AT ALL LOCATIONS HAVING A LONGITUDINAL ROAD SLOPE EQUAL TO OR GREATER THAN 1%.

GENERAL NOTES:

1. DETAILS OF CONSTRUCTION, MATERIALS, AND WORKMANSHIP NOT SHOWN ON THIS DRAWING SHALL CONFORM TO THE PERTINENT REQUIREMENTS OF THE STANDARD SPECIFICATIONS AND THE APPLICABLE SPECIAL PROVISIONS.
2. DETAIL DRAWINGS FOR PROPOSED ALTERNATE DESIGNS FOR INLET COVERS SHALL BE SUBMITTED TO THE ENGINEER FOR APPROVAL PROVIDING THAT SUCH ALTERNATE DESIGNS MAKE PROVISION FOR EQUIVALENT CAPACITY AND STRENGTH.
3. ROUND FRAMES AND COVERS SHALL HAVE CONTINUOUSLY MACHINED BALL BEARING SURFACES TO PREVENT ROCKING AND RATTLING.
4. THE ACTUAL WEIGHT OF COVERS MAY VARY WITHIN 5 PERCENT (PLUS OR MINUS) OF THE APPROXIMATE WEIGHT.
5. THE INSIDE DIMENSIONS OF THE STANDARD "H" INLET SHALL BE ALTERED TO 2' -4" X 1' -6" WHEN A TYPE "S" INLET IS SPECIFIED PER STANDARD DETAIL DRAWING 5.7.7
6. INLETS SHALL BE DEPRESSED IN THE CURB FLOW LINE, SEE MADISON STANDARD DETAIL DRAWING 5.5.7

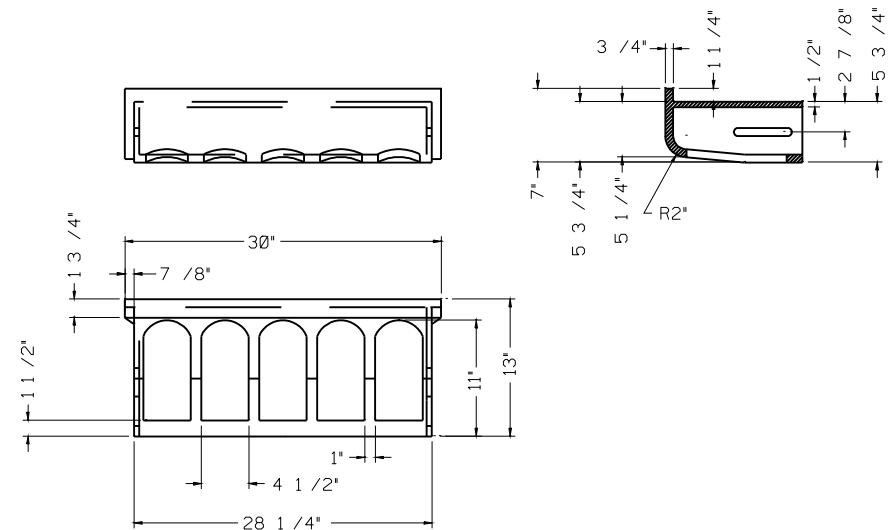

2008

CITY OF MADISON  
ENGINEERING DIVISION

R-3281

STANDARD DETAIL DRAWING 5.7.25



TYPE 'A' CURB

TYPE 'B' CURB

INLET ALONG  
STRAIGHT SECTION

INLET ALONG  
STRAIGHT SECTION

OPTION 1  
OFFSET & GRADE  
TO FACE OF CURB

OPTION 1  
OFFSET & GRADE  
TO FACE OF CURB

OPTION 2  
OFFSET & GRADE  
TO FACE OF CURB  
(ONE STAKE ON  
EACH SIDE)

OPTION 2  
OFFSET & GRADE  
TO FACE OF CURB  
(ONE STAKE ON  
EACH SIDE)

INLET ALONG  
CURVED SECTION

INLET ALONG  
CURVED SECTION

RADIUS  
POINT

RADIUS  
POINT

OFFSET & GRADE  
TO FACE OF CURB

OFFSET & GRADE  
TO FACE OF CURB

5.7.26

2004

CITY OF MADISON  
ENGINEERING DIVISION

CONSTRUCTION STORM  
STAKING LAYOUT

STANDARD DETAIL DRAWING 5.7.26

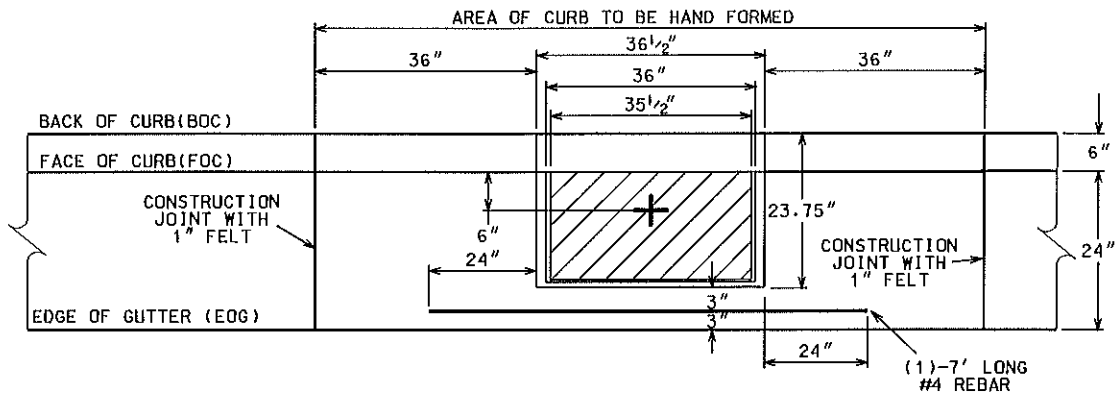

**TYPE "A" CURB AND GUTTER**  
PLAN VIEW

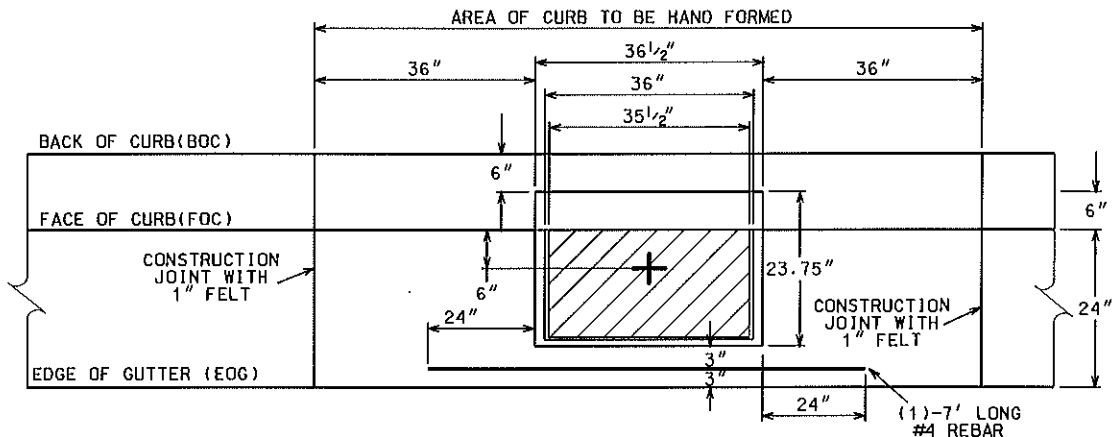

**TYPE "B" CURB AND GUTTER**  
PLAN VIEW

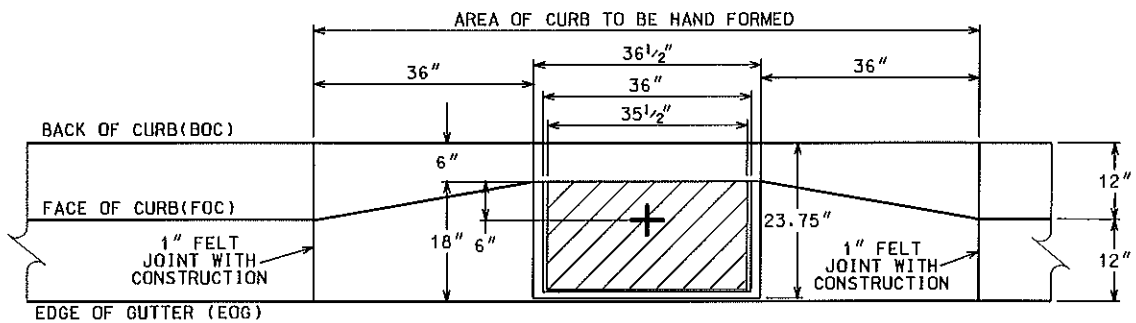

**TYPE "H" CURB AND GUTTER**  
PLAN VIEW

NOTE:  
CASTING FLANGE (NOT SHOWN) PROTRUDES  
APPROXIMATELY 3.63" INTO THE PAVEMENT.  
SEE SDD 5.7.18 FOR INLET FRAME DETAILS.

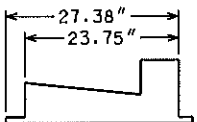

**INLET CASTING**  
SIDE VIEW

+ = CENTER OF STRUCTURE  
(STATION AND OFFSET  
AS INDICATED ON THE  
STORM SCHEDULE)

DRAWING NOT TO SCALE

2006
CITY OF MADISON ENGINEERING DIVISION
<b>H INLET LOCATIONS IN DIFFERENT CURB TYPES</b>
STANDARD DETAIL DRAWING 5.7.27

5.7.28

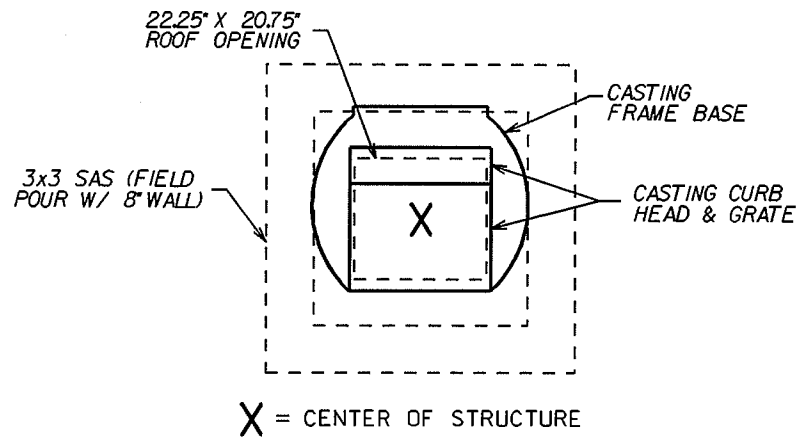

**TOP VIEW**  
**STRUCTURE WITH CASTING**

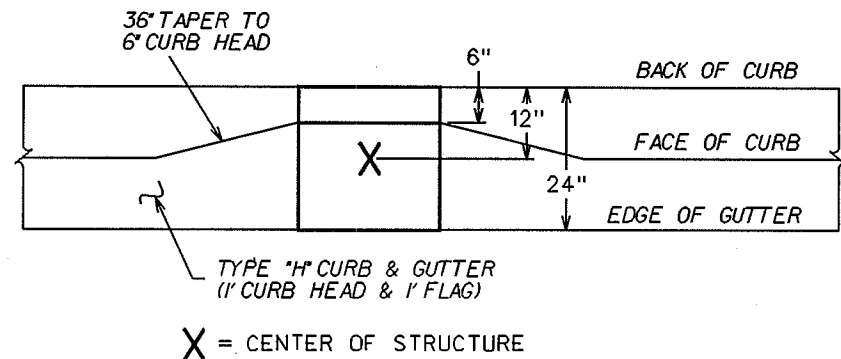

**TOP VIEW**  
**CASTING WITH CURB & GUTTER**

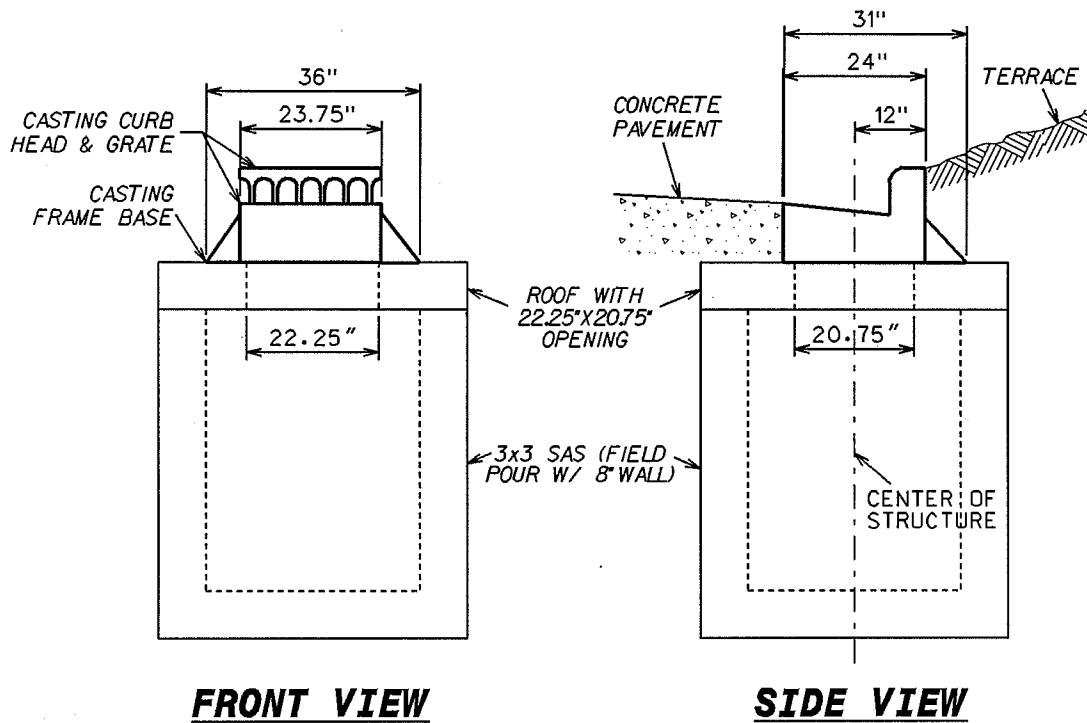

**FRONT VIEW**

**SIDE VIEW**

**NOTES:**

- (1) TYPE "H" CURB & GUTTER TYPICALLY USED IN MEDIAN DESIGN & CONSTRUCTION.
- (2) NEENAH CASTING NUMBERS: INLETS AT LOW POINTS [R-3278-A] INLETS ON GRADE [R-3278-AL]
- (3) CONSTRUCT SEWER ACCESS STRUCTURE (SAS) PER STANDARD DETAIL DRAWING 5.4.11
- (4) CONSTRUCT CURB TAPER PER STANDARD DETAIL DRAWING 5.7.27

2004

CITY OF MADISON ENGINEERING DIVISION
<b>INLETS IN TYPE "H" CURB &amp; GUTTER WITH CONCRETE PAVEMENT</b>
STANDARD DETAIL DRAWING 5.7.28

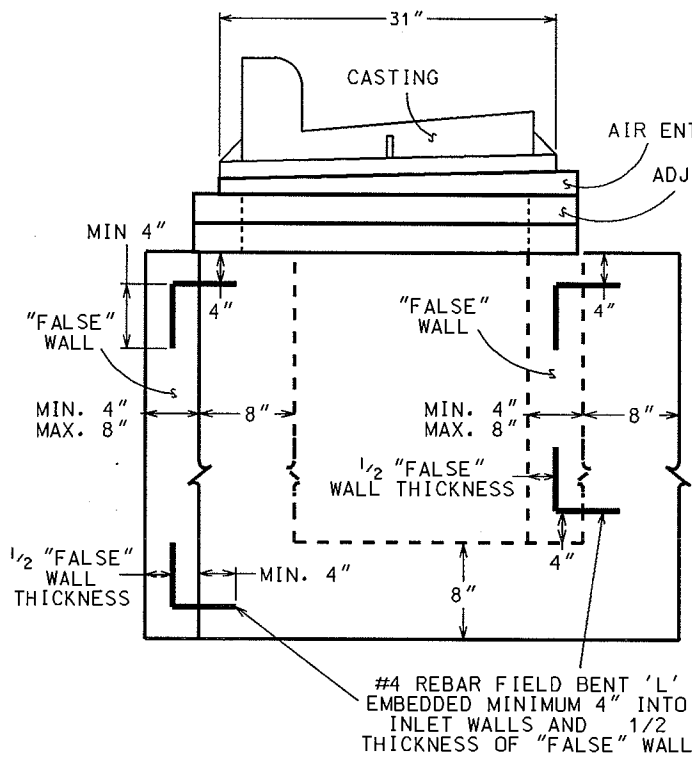

OFFSET USING FALSE WALL  
INLET SIDE VIEW

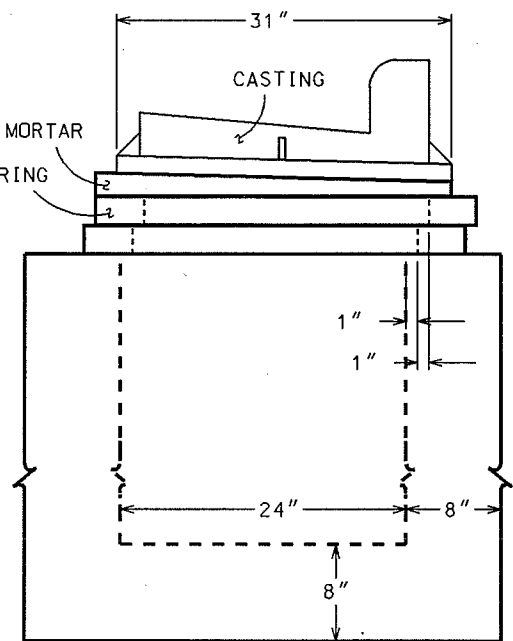

OFFSET USING ADJUSTING RINGS  
INLET SIDE VIEW

NOTE:

TO INSURE THE INLET CASTING IS ALIGNED CORRECTLY WITH THE CURB AND GUTTER, AN OFFSET OF THE INLET CASTING MAY BE REQUIRED. THE ACCEPTABLE INLET CASTING OFFSETS ARE SHOWN AND THE GUIDELINES ARE AS FOLLOWS:

- (1) IF THE ADJUSTMENT REQUIRED IS LESS THAN TWO (2) INCHES, THIS CAN BE OBTAINED BY TWO ONE (1) INCH SHIFTS OF THE ADJUSTING RINGS A MAXIMUM OF ONE (1) INCH EACH AND/OR A ONE (1) INCH SHIFT OF THE CASTING.
- (2) IF THE ADJUSTMENT REQUIRED IS GREATER THAN TWO (2) INCHES AND LESS THAN FOUR (4) INCHES, THE INLET CASTING OFFSET SHALL BE OBTAINED BY THE CONSTRUCTION OF ONE FOUR (4) INCH THICK "FALSE" WALL ADJACENT TO THE INLET WALL THAT PROVIDES FULL SUPPORT OF THE CASTING. THE PLACEMENT AND ANCHORING SHALL BE CONSTRUCTED IN THE MANNER SHOWN.
- (3) IF THE ADJUSTMENT REQUIRED IS GREATER THAN FOUR (4) INCHES AND LESS THAN EIGHT (8) INCHES, THE INLET CASTING OFFSET SHALL BE OBTAINED BY THE CONSTRUCTION OF TWO FALSE WALLS WITH EQUAL WALL THICKNESSES VARYING FROM FOUR (4) TO EIGHT (8) INCHES DEPENDING ON THE OFFSET REQUIRED. THE PLACEMENT AND ANCHORING SHALL BE CONSTRUCTED IN THE MANNER SHOWN.
- (4) IF THE ADJUSTMENT REQUIRED IS GREATER THAN EIGHT (8) INCHES, THE INLET SHALL BE REPOSITIONED OR RECONSTRUCTED TO REDUCE THE OFFSET.

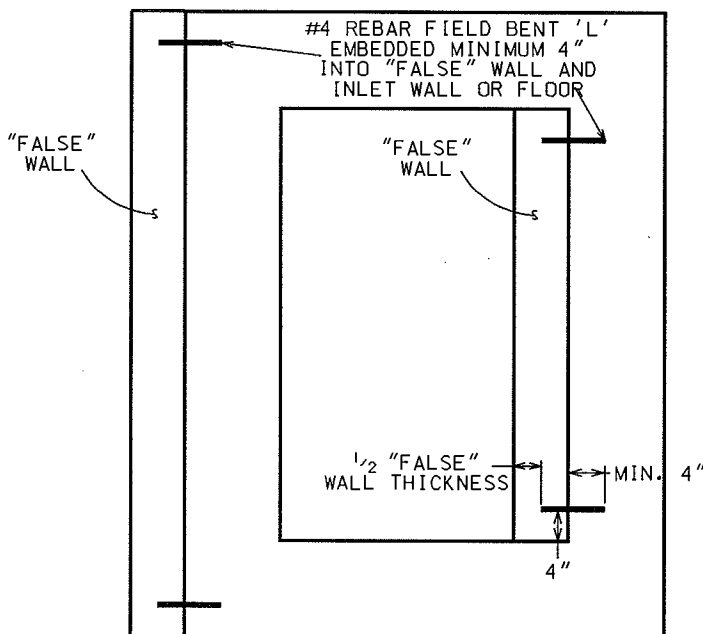

OFFSET USING FALSE WALL  
INLET TOP VIEW

THESE SPECIFICATIONS ARE APPLICABLE FOR BOTH POURED-IN-PLACE AND PRECAST INLETS. THE DETAIL SHOWS A POURED-IN-PLACE INLET. A PRECAST INLET WOULD ONLY DIFFER WITH A WALL THICKNESS OF 5".

2004

CITY OF MADISON  
ENGINEERING DIVISION

**INLET CASTING  
OFFSET CRITERIA  
FOR H INLETS**

STANDARD DETAIL DRAWING 5.7.29

5.7.30

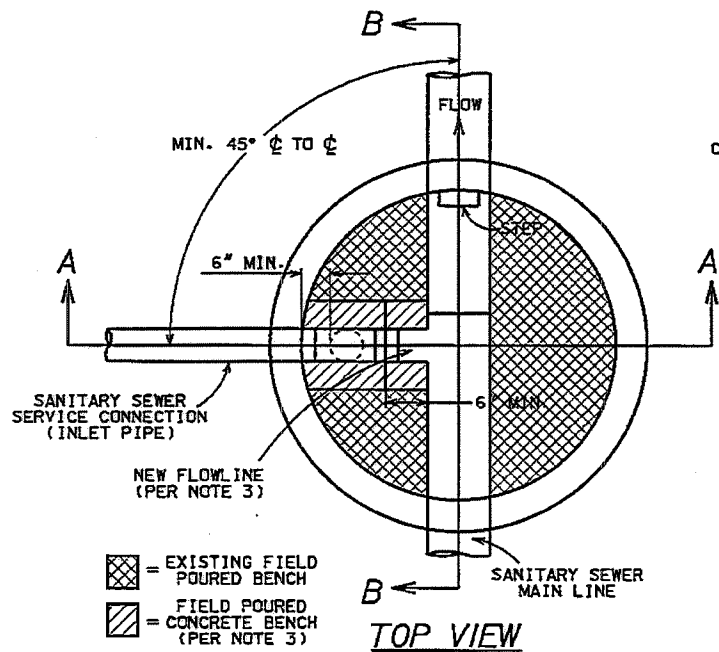

**TOP VIEW**

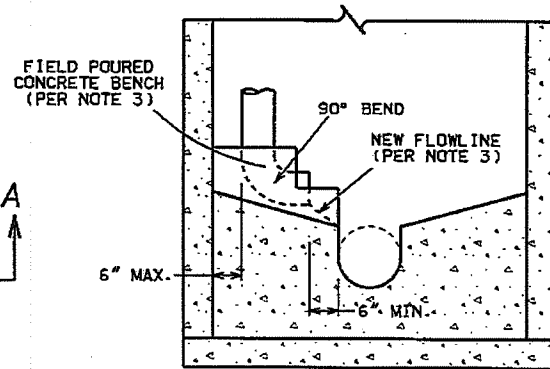

**SIDE VIEW  
FIELD Poured  
CONCRETE BENCH**

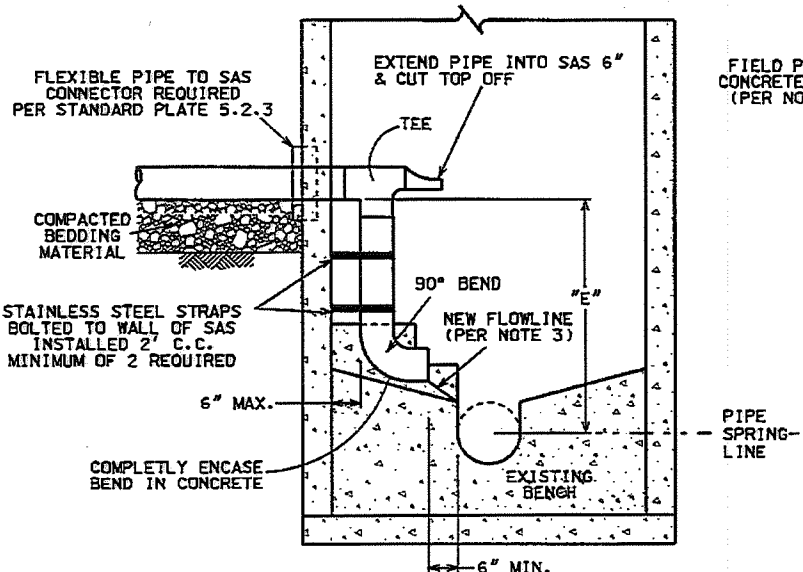

**SECTION A-A**

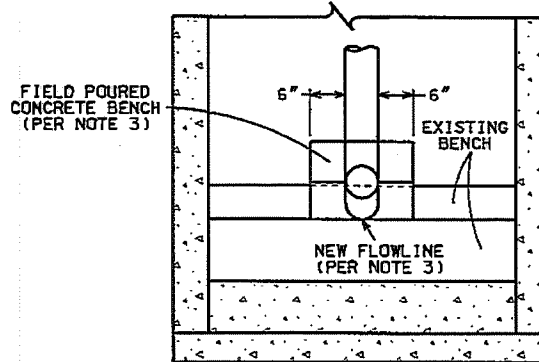

**SECTION B-B**

**NOTES:**

- 1) INSIDE DROP INLETS SHALL BE USED ONLY WHERE SITE CONDITIONS MAKE AN OUTSIDE DROP CONNECTION INFEASIBLE TO CONSTRUCT. THIS DETERMINATION SHALL BE MADE BY THE ENGINEER IN THE FIELD. THE CONTRACTOR SHALL OBTAIN APPROVAL FOR INSTALLATION OF THE INSIDE DROP INLET FROM THE ENGINEER PRIOR TO CONSTRUCTION.
- 2) DROP INLET SHALL BE BUILT WHEN "E" IS GREATER THAN 24" AND THE INLET PIPE DIAMETER IS 6" OR LESS. INLET PIPES GREATER THAN 6" SHALL HAVE AN OUTSIDE DROP CONNECTION PER STANDARD DETAIL DRAWING 5.7.2 "E" SHALL BE MEASURED FROM THE INVERT OF THE INCOMING PIPE TO THE SPRINGLINE OF THE OUTGOING SEWER.
- 3) ENCASE INLET PIPE IN CONCRETE FROM THE EXISTING BENCH TO FIRST JOINT ABOVE THE 90° BEND. FORM NEW SMOOTH FLOWLINE FROM PIPE END TO MAIN CHANNEL. ROUGH BRUSH FINISH ALL OTHER SURFACES OF THE NEW CONCRETE ENCASEMENT.

DRAWING NOT TO SCALE

2010
CITY OF MADISON ENGINEERING DIVISION
INSIDE DROP FOR SANITARY LATERAL
STANDARD DETAIL DRAWING 5.7.30

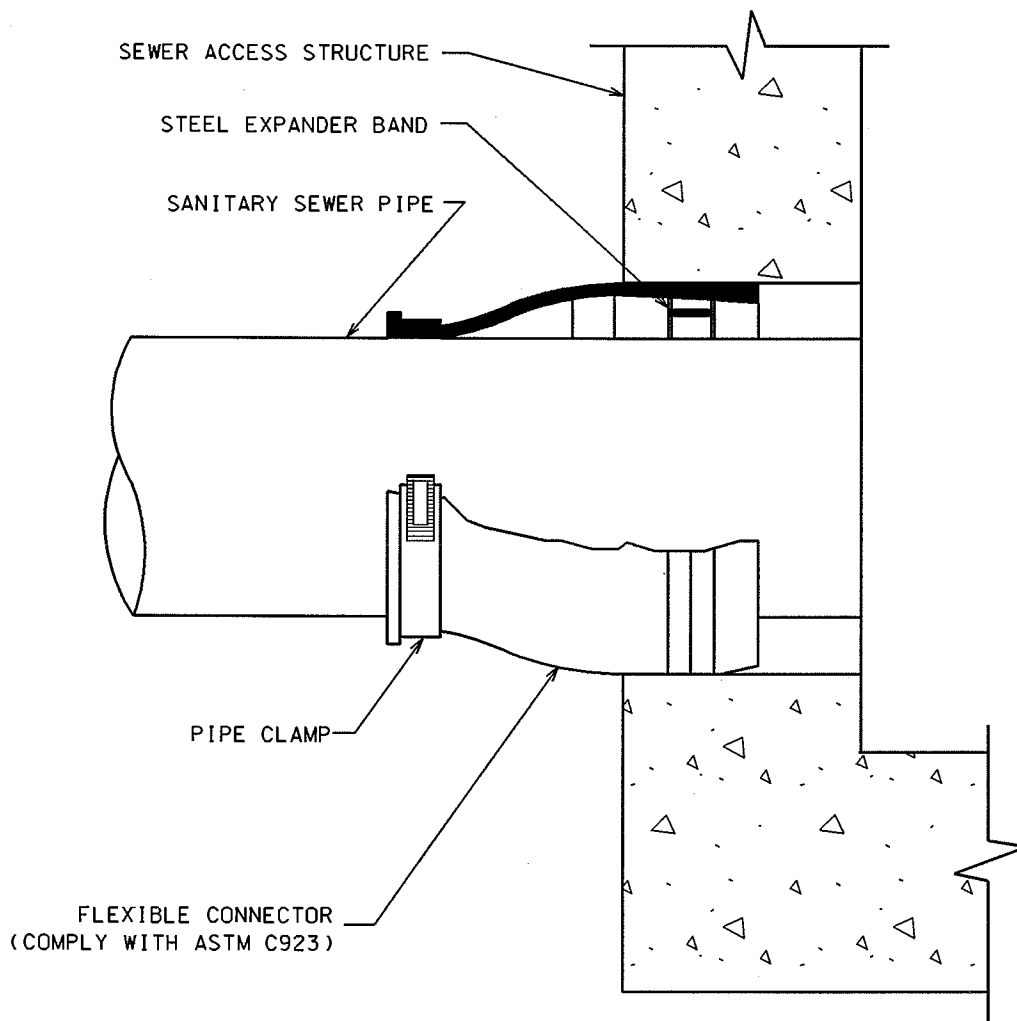

NOTES:

1. S.A.S. CONNECTIONS FOR SANITARY SEWER MAINS SHALL BE MADE USING FLEXIBLE, WATERTIGHT CONNECTIONS SUCH AS KOR-N-SEAL I OR APPROVED EQUAL, UNLESS DIRECTED OTHERWISE BY ENGINEER.
2. ALL STAINLESS STEEL ELEMENTS OF CONNECTOR SHALL BE TOTALLY NON-MAGNETIC SERIES 304 STAINLESS, EXCLUDING THE WORM SCREW FOR TIGHTENING THE STEEL BAND AROUND THE PIPE WHICH SHALL BE SERIES 305 STAINLESS. THE WORM SCREW FOR TIGHTENING THE STEEL BAND SHALL BE TORQUED BY A BREAK-AWAY TORQUE WRENCH AVAILABLE FOR THE PRECAST S.A.S SUPPLIER AND SET FOR 60 - 70 INCH/LBS.
3. THE CONNECTOR SHALL BE INSTALLED IN THE S.A.S. WALL BY ACTIVATING THE EXPANDING MECHANISM IN STRICT ACCORDANCE WITH THE RECOMMENDATIONS OF THE CONNECTOR MANUFACTURER.
4. THE CONNECTOR SHALL BE OF A SIZE SPECIFICALLY DESIGNED FOR THE PIPE MATERIAL AND SIZE BEING UTILIZED ON THE PROJECT.
5. ALL COSTS SHALL BE CONSIDERED INCIDENTAL TO THE S.A.S. AND/OR PIPE. THE ENGINEER RESERVES THE RIGHT TO REQUIRE A "CONCRETE ENCASEMENT" CONNECTION AT NO ADDITIONAL EXPENSE IN THE EVENT OF DESIGN CHANGE.
6. FLEXIBLE, WATERTIGHT CONNECTIONS SHALL ALSO BE USED AS REQUIRED FOR STORM SEWER CONNECTIONS.

2004

CITY OF MADISON ENGINEERING DIVISION
<b>FLEXIBLE PIPE TO S.A.S. CONNECTOR</b>
STANDARD DETAIL DRAWING 5.7.31

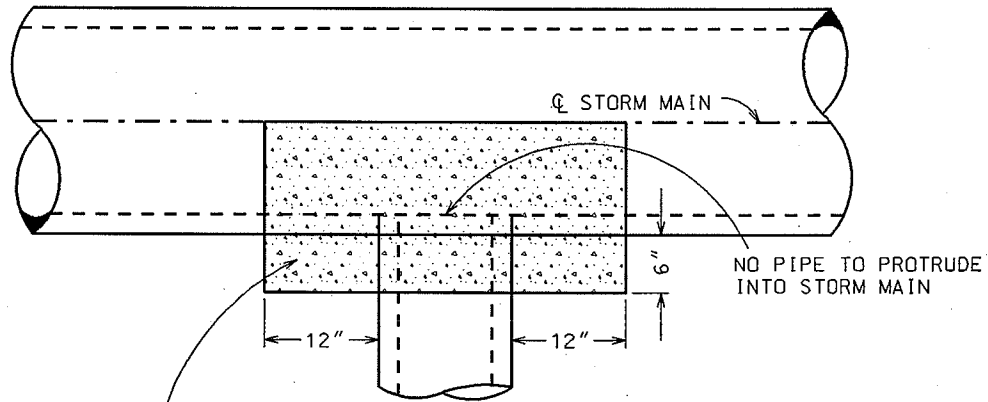

TOP VIEW

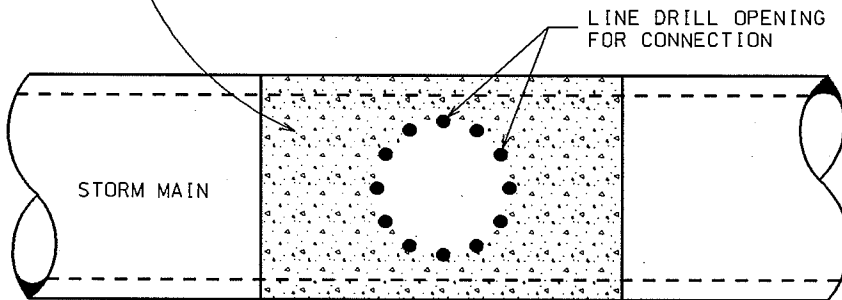

SIDE VIEW

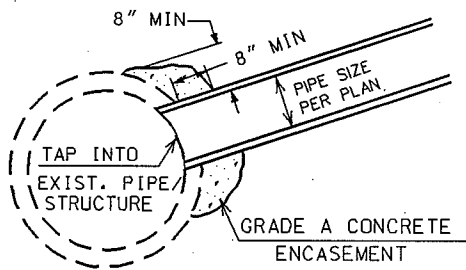

ALTERNATE CONCRETE ENCASUREMENT

DRAWING NOT TO SCALE

2004

CITY OF MADISON  
ENGINEERING DIVISION

STORM SEWER  
TAP DETAIL

STANDARD DETAIL DRAWING 5.7.32

GUTTER INLET DETAIL DRAWING

TAPER TYPICAL GUTTER SECTION OVER  
1' ON EITHER SIDE OF INLET; MAINTAIN  
1" FLOWLINE DEPRESSION AND MATCH  
INLET CROSS SECTION AT INLET INTERFACE

TYPICAL ALLEY  
GUTTER SECTION

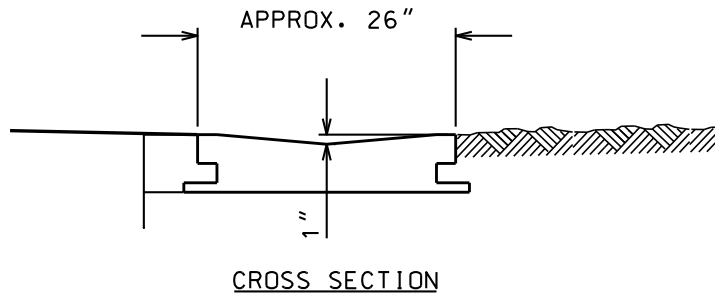
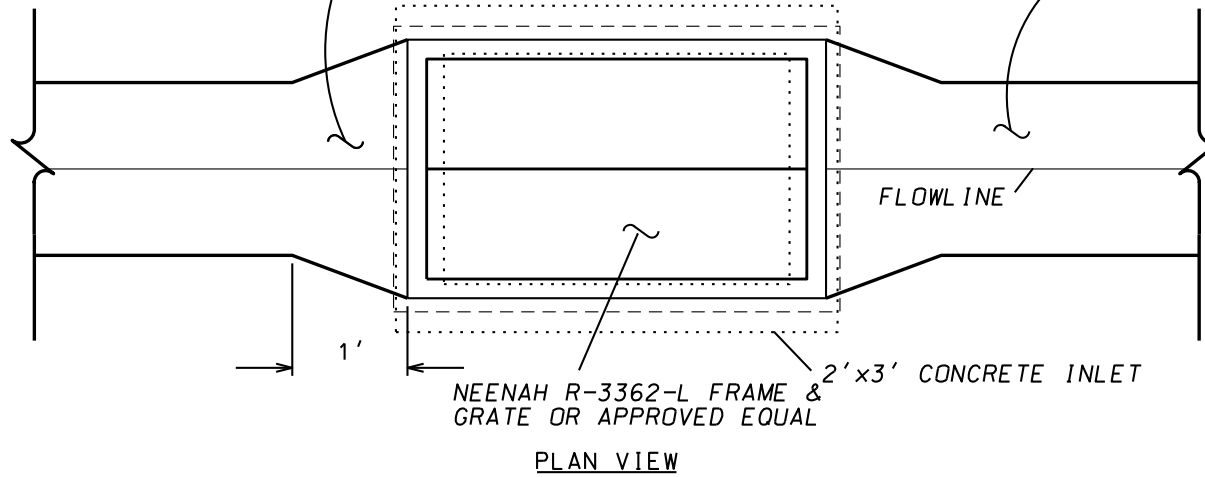

DRAWING NOT TO SCALE

2014

CITY OF MADISON  
ENGINEERING DIVISION

H INLET  
ALLEY CURB

STANDARD DETAIL DRAWING 5.7.33

5.7.33



5.7.34

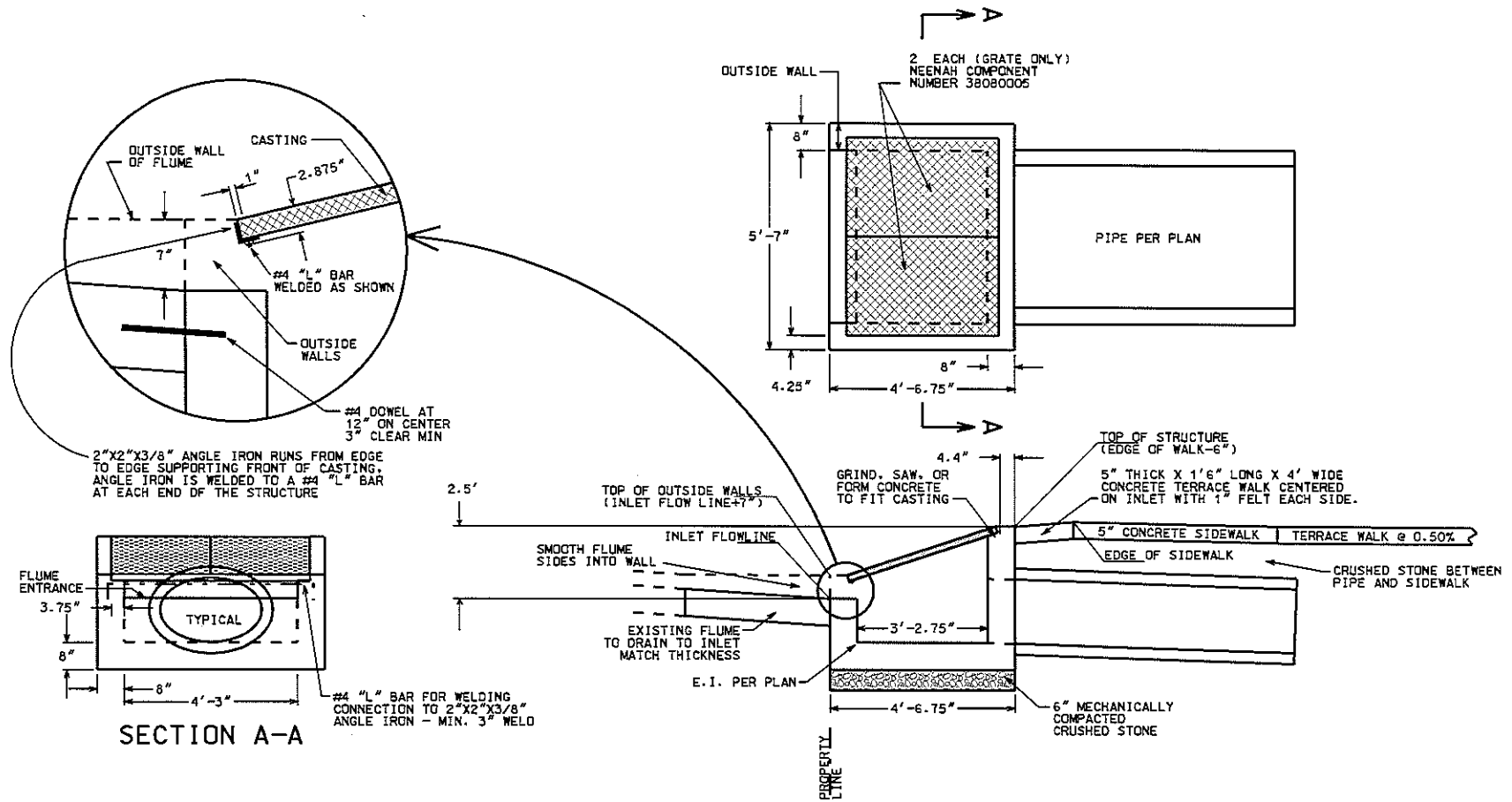

2006

CITY OF MADISON  
ENGINEERING DIVISION

# DITCH INLET STRUCTURE

STANDARD DETAIL DRAWING 5.7.34

5.7.35

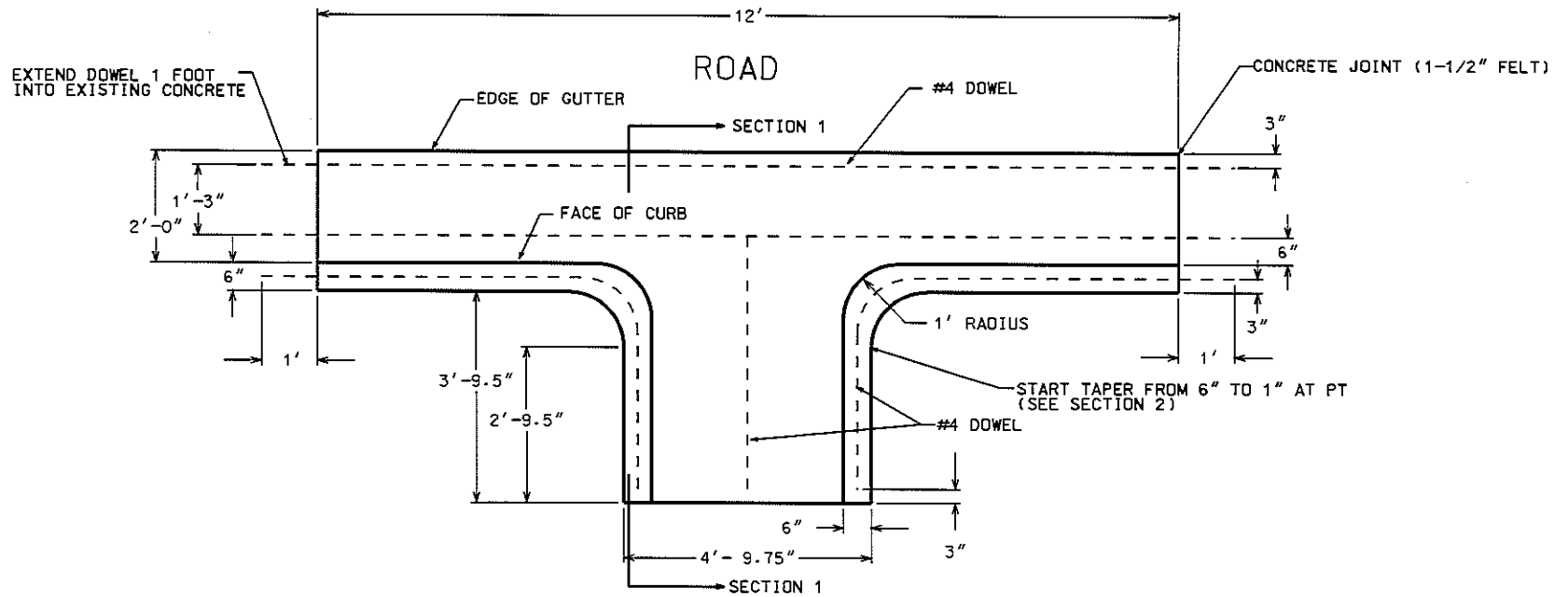

### PLAN VIEW

DOES NOT REPRESENT CONSTRUCTION JOINT (LINE REPRESENTS BACK OF CURB)

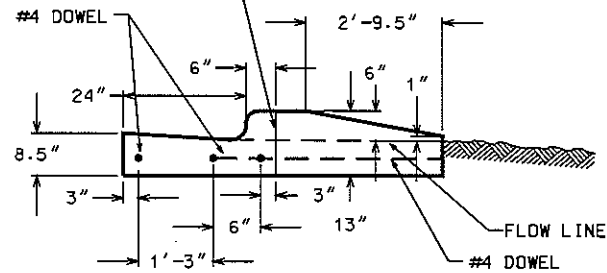

NOTE: TYPE 'A' CONCRETE CURB AND GUTTER IS SHOWN

### SECTION 1

2006

CITY OF MADISON  
ENGINEERING DIVISION

TERRACE FLUME

STANDARD DETAIL DRAWING 5.7.35



5.7.37

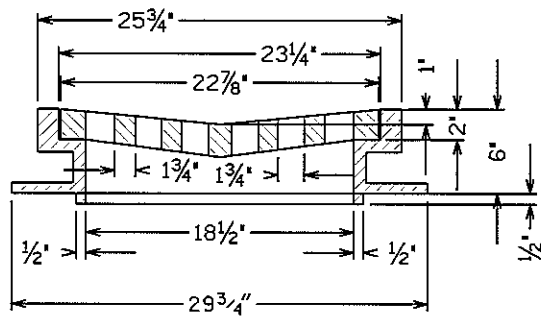
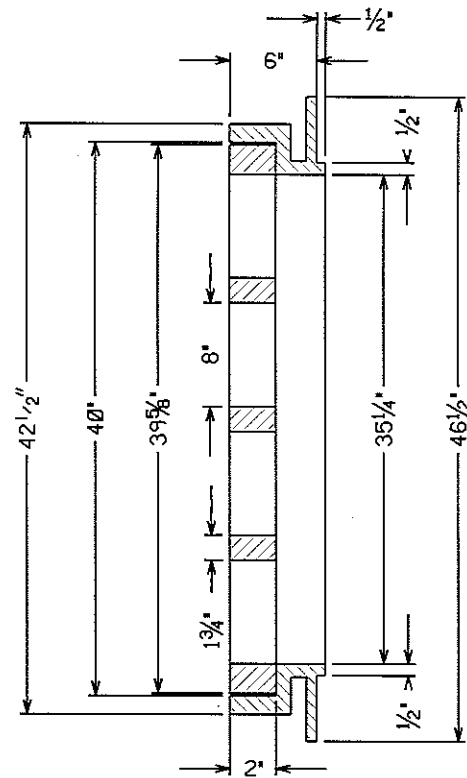
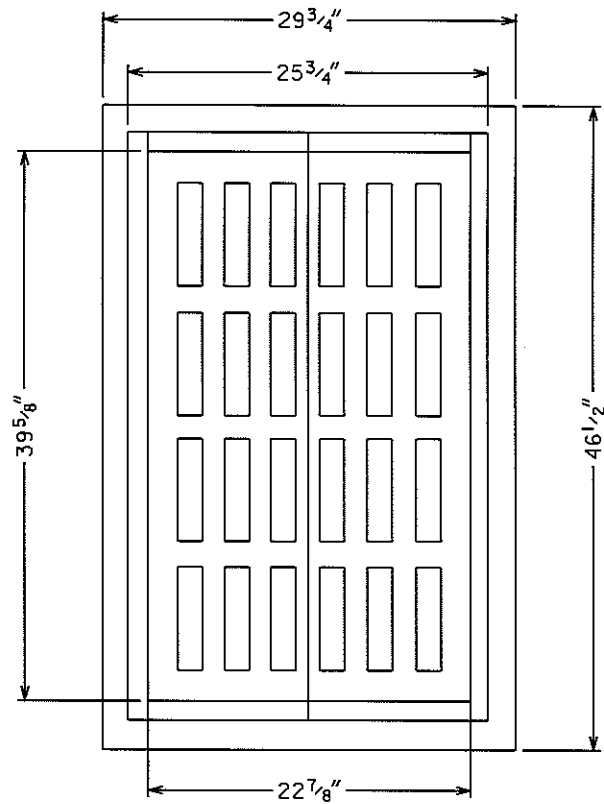

HEAVY DUTY

MATERIAL: CAST GRAY IRON ASTM A-48, CLASS 35B

NOT TO SCALE

2006

CITY OF MADISON  
ENGINEERING DIVISION

RIBBON CURB CASTING  
NEENAH R-3382

STANDARD DETAIL DRAWING 5.7.37

5.7.38

TYPE "C" CHECKERED  
TOP DESIGN

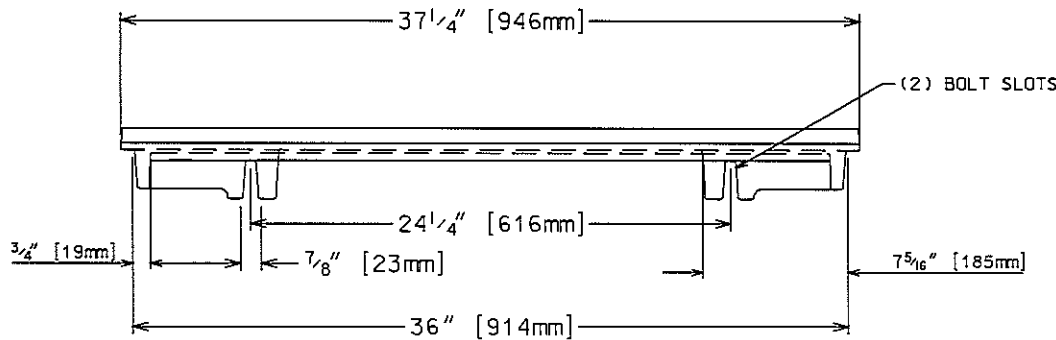
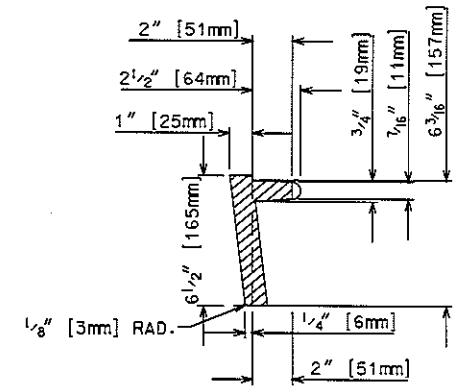
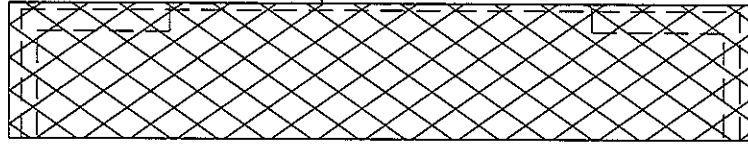

MATERIAL: DUCTILE IRON 55+ KSI YIELD  
NOTE: ALL DIMENSIONS ARE IN ENGLISH AND [METRIC]  
WEIGHT: 77#  
FINISH: NOT PAINTED

2007

CITY OF MADISON  
ENGINEERING DIVISION

R-3067-7000  
MOUNTABLE CURB PLATE

STANDARD DETAIL DRAWING 5.7.38

SEE SDD 5.7.39A FOR FURTHER INFORMATION  
NOTE: DIMENSIONS ARE IN UNITS OF INCHES

ALTERNATE ROOF DETAIL

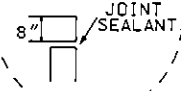

SECTION A-A

SECTION B-B

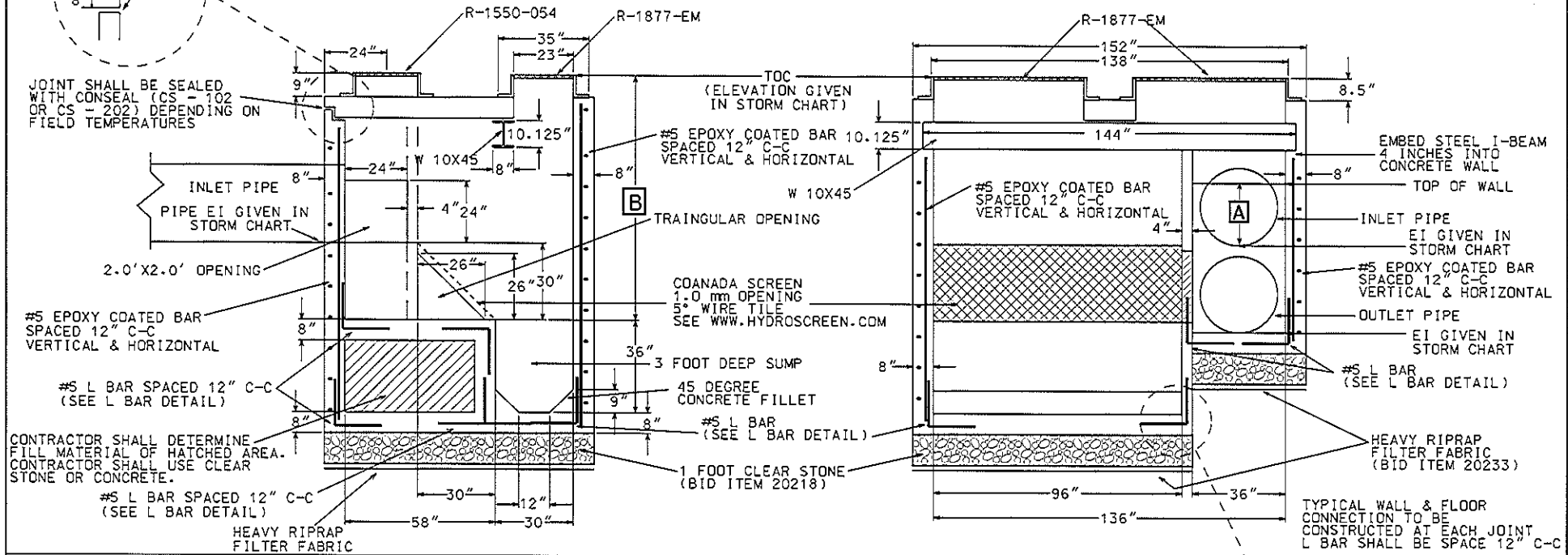

5.7.39

ROOF REINFORCEMENT

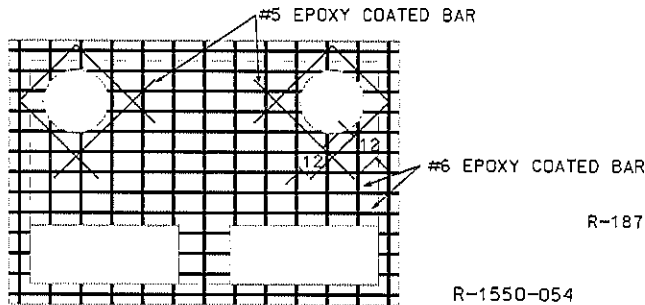

NOT ALL REBAR SHOWN FOR CLARITY

ROOF REINFORCEMENT NOTES:

1. EPOXY COATED REBARS SHALL BE USED IN ALL CASES
2. #6 REBARS PLACED ON 6" CENTERS
3. 3" CLEAR SHALL BE MAINTAINED
4. ROOF THICKNESS SHALL BE 8" MINIMUM

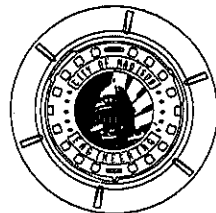

TOP VIEW

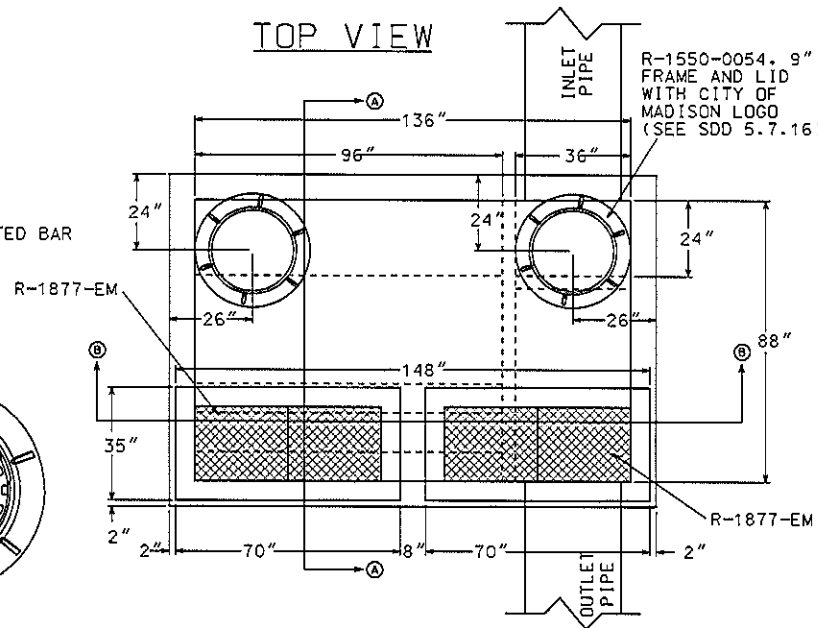

TYPICAL WALL & FLOOR CONNECTION TO BE CONSTRUCTED AT EACH JOINT. L BAR SHALL BE SPACE 12" C-C

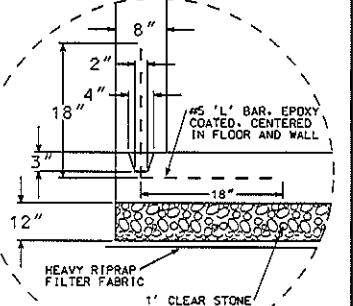

2012

CITY OF MADISON  
ENGINEERING DIVISION

SCREEN TREATMENT  
DEVICE

STANDARD DETAIL DRAWING 5.7.39



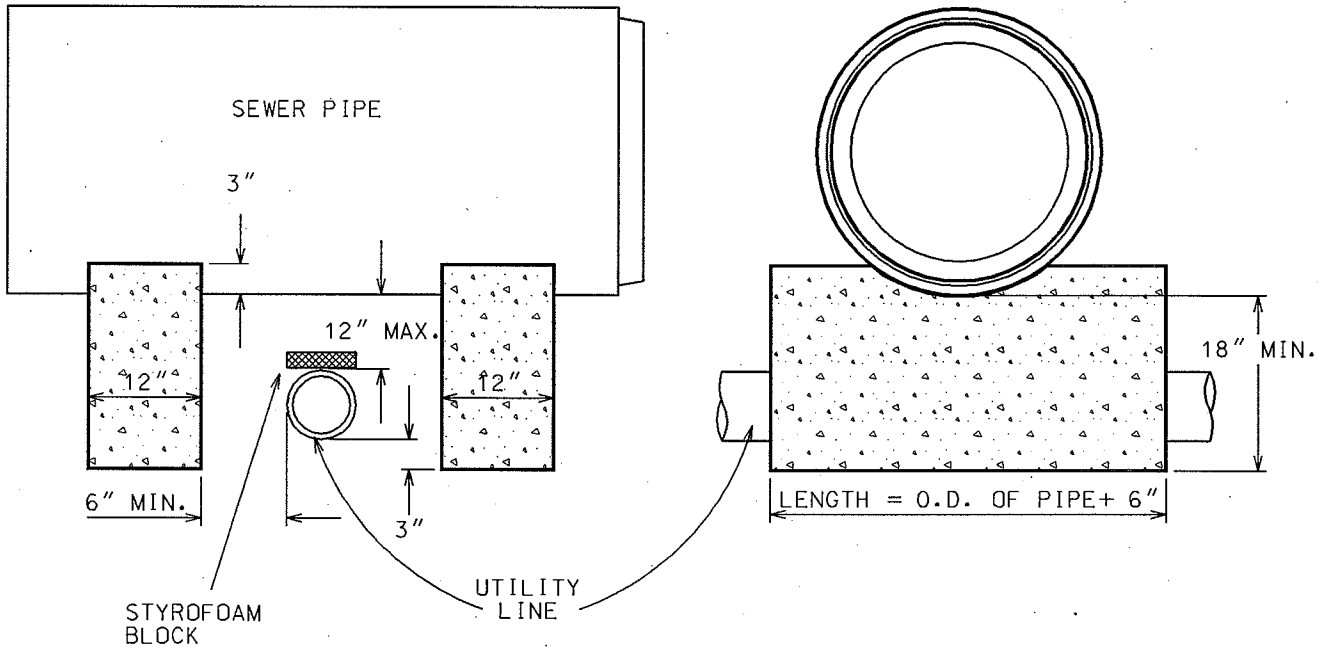
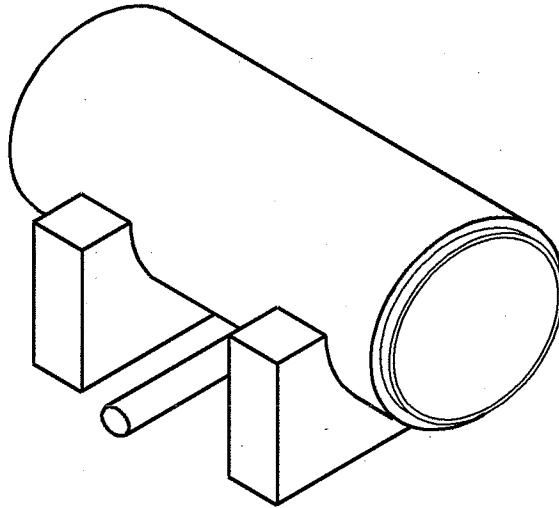

NOTE:

FIELD POURED, CONCRETE PIPE SUPPORTS SHALL BE INSTALLED FOR SEWERS OVER 10" IN DIAMETER WHEN CLEARANCE BETWEEN BOTTOM OF PIPE & TOP OF UTILITY LINE IS 12" OR LESS.

2004

CITY OF MADISON  
ENGINEERING DIVISION

CONCRETE  
SUPPORTS

STANDARD DETAIL DRAWING 5.8.1



REINFORCED CONCRETE BEAM UTILITY LINE SUPPORT TO BE USED WHEN NEW SEWER EXCAVATION IS CROSSING UNDER AN EXISTING UTILITY LINE (SEWER LINES, WATER LINES, GAS LINES, ETC.) AS DIRECTED BY THE ENGINEER.

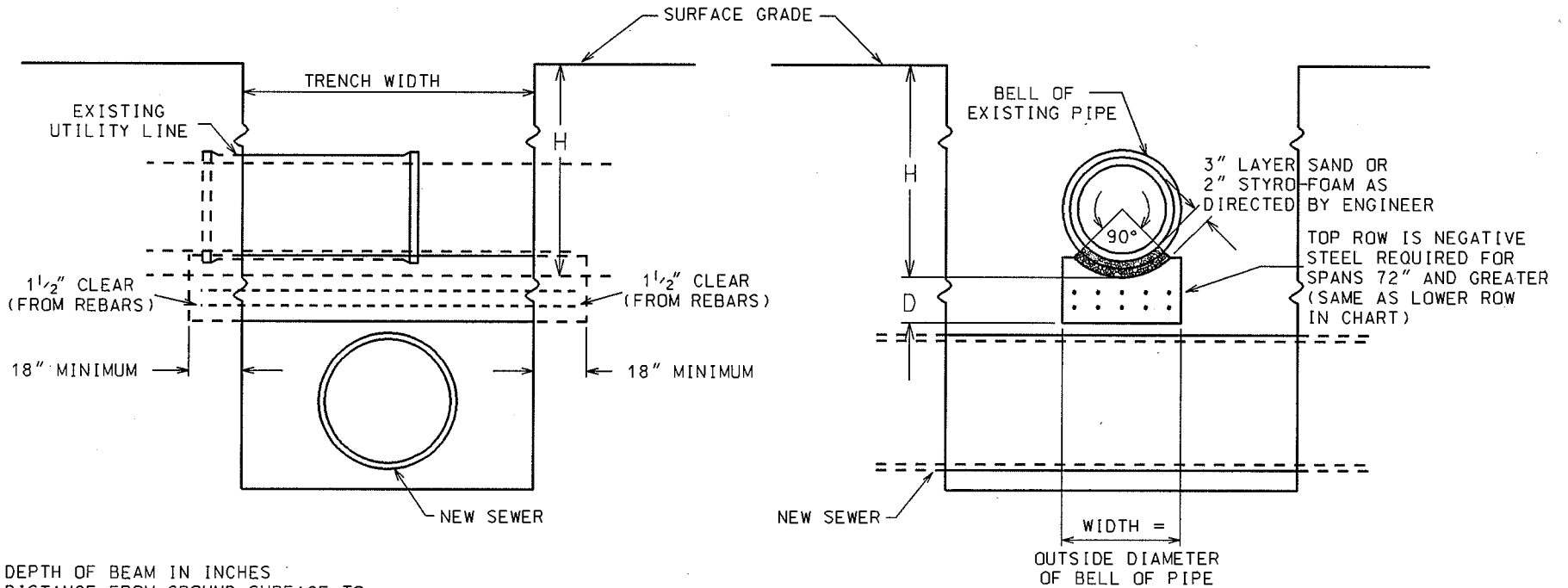

D = DEPTH OF BEAM IN INCHES  
H = DISTANCE FROM GROUND SURFACE TO  
BOTTOM OF PIPE SAND/STYRO-FOAM SUBSURFACE

TRENCH WIDTH	24" - 43"		44" - 58"		59" - 72"		73" - 87"	
H, ft	D	STEEL REQ'D	D	STEEL REQ'D	D	STEEL REQ'D	D	STEEL REQ'D
4 TO 5	6	#4 - 6" OC	7	#4 - 5" OC	8	#5 - 6" OC	9	#5 - 5" OC
5 TO 7	6	#4 - 6" OC	7	#5 - 6" OC	8	#5 - 5" OC	9	#5 - 5" OC
7 TO 9	6	#4 - 6" OC	7	#5 - 6" OC	8	#5 - 5" OC	9	#5 - 4" OC
9 TO 12	7	#4 - 6" OC	8	#5 - 6" OC	9	#5 - 4" OC	10	#5 - 4" OC
12 TO 15	7	#4 - 5" OC	9	#5 - 6" OC	10	#5 - 4" OC	12	#5 - 4" OC

2004

CITY OF MADISON  
ENGINEERING DIVISION

REINFORCED CONCRETE BEAM  
UTILITY LINE SUPPORT

STANDARD DETAIL DRAWING 5.8.2

5.8.2

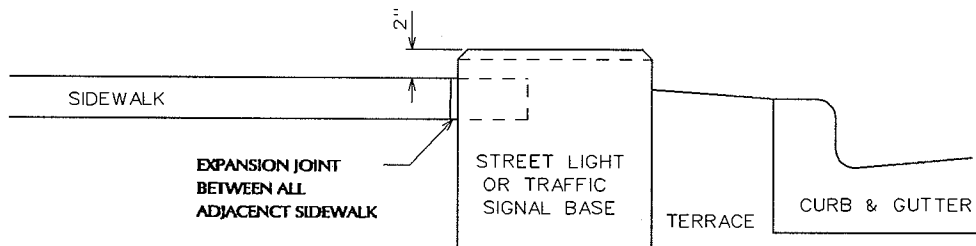
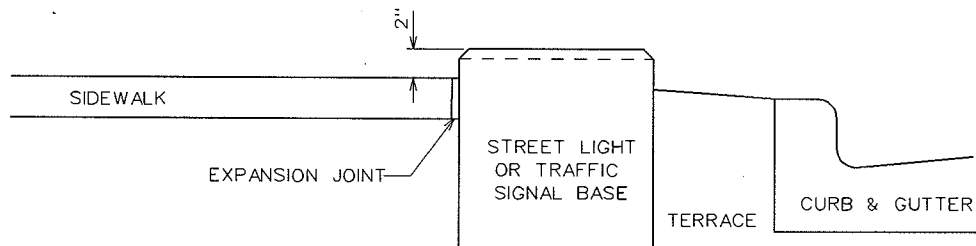
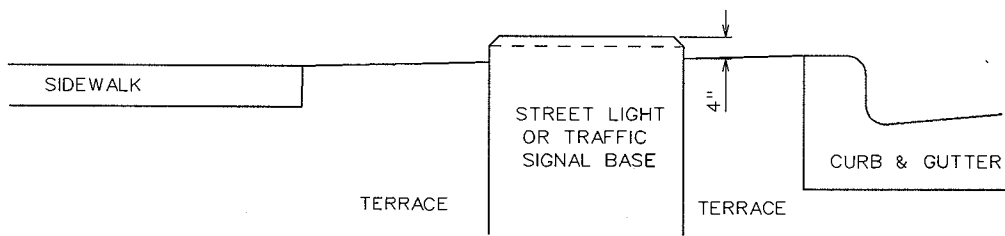
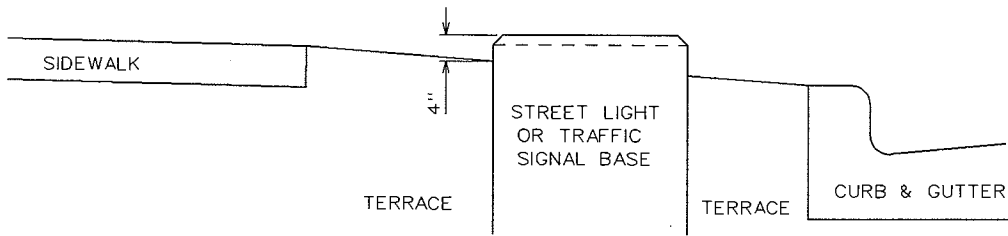

2004

CITY OF MADISON  
TRAFFIC ENGINEERING DIVISION

TYPICAL ELEVATIONS  
FOR BASES

STANDARD DETAIL DRAWING 6.01

6.02

TYPICAL IMPRINT FOR MARKING  
LOCATION OF DUCT AT  
STREET CROSSING

PVC (SCHEDULE 80)  
CONDUIT AS REQ'D

PVC (SCHEDULE 80)  
CONDUIT AS "RACEWAY"  
FOR CABLE-IN-DUCT

CABLE-IN-DUCT

12" MAXIMUM

BACK OF CURB

PVC (SCHEDULE 40)  
CONDUIT AS REQ'D

INSTALLATION DEPTH

UNDER ROADWAY 24" MINIMUM, 36" MAXIMUM

IN TERRACE OR UNDER SIDEWALK 30" MINIMUM, 36" MAXIMUM

2004

CITY OF MADISON  
TRAFFIC ENGINEERING DIVISION

TYPICAL PLAN VIEW  
OF DUCT INSTALLATION  
& DUCT IMPRINT LOCATION

STANDARD DETAIL DRAWING 6.02

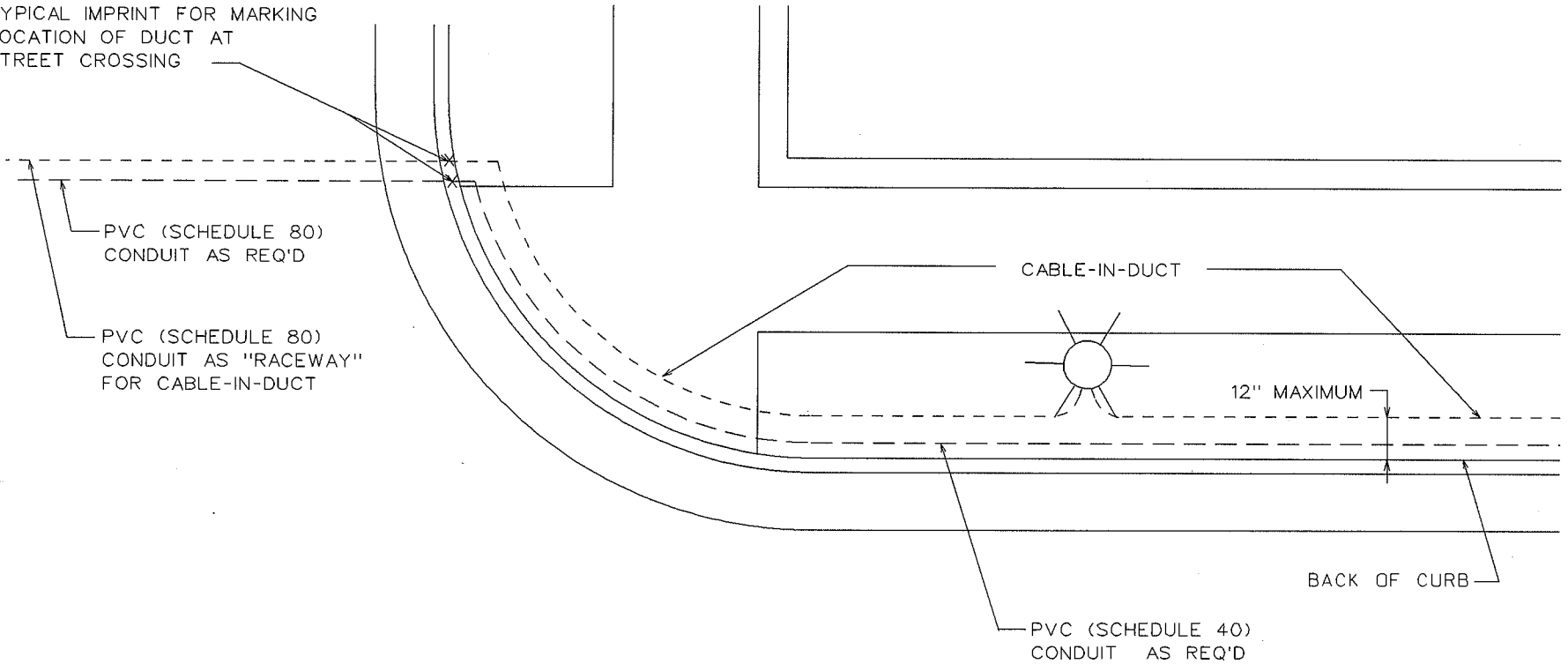

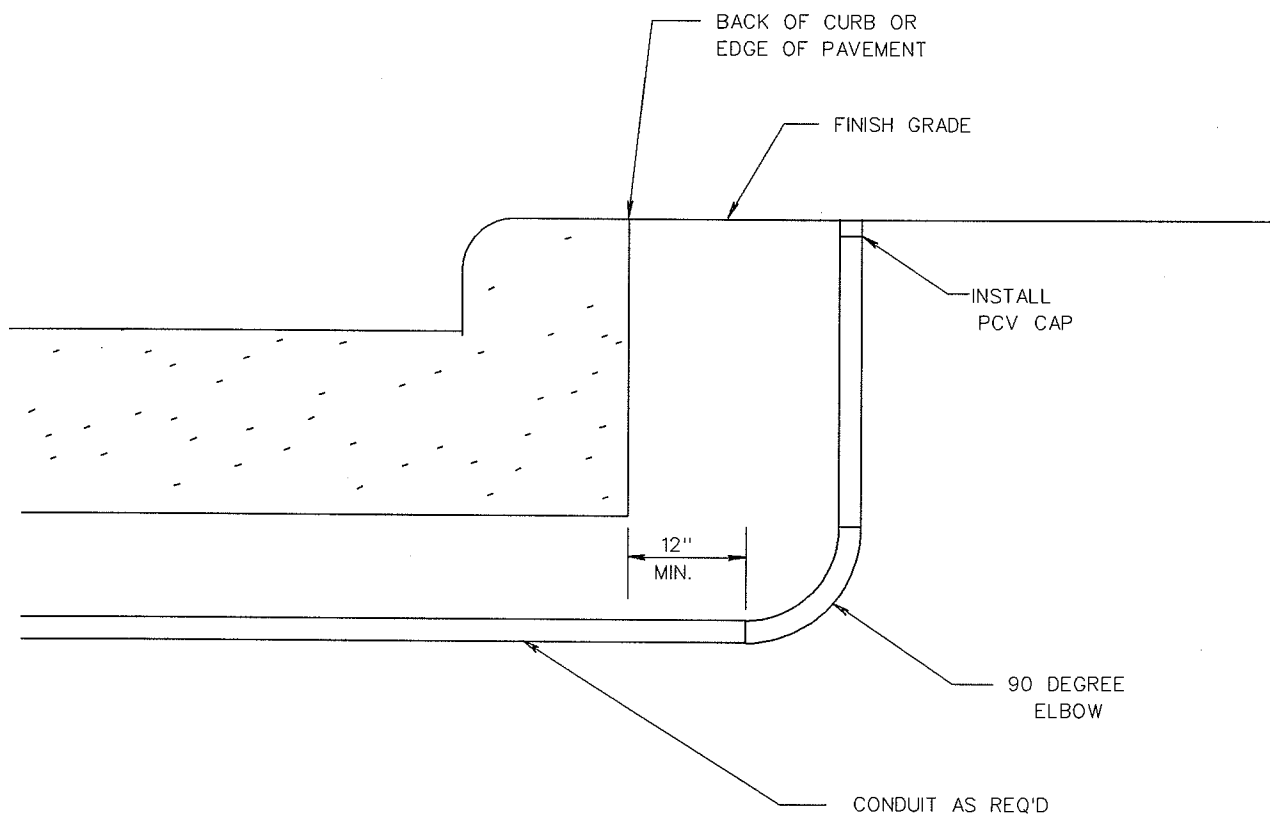

2004

CITY OF MADISON  
TRAFFIC ENGINEERING DIVISION

DUCT TERMINATION  
DETAIL

STANDARD DETAIL DRAWING 6.03

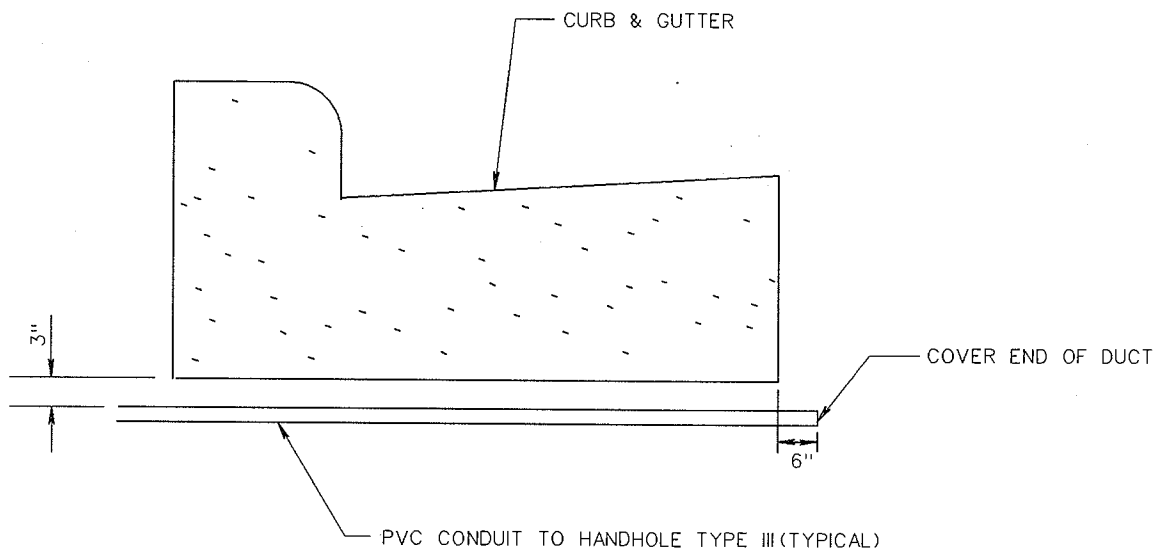

LOOP LEAD DUCT DETAIL

2004

CITY OF MADISON  
TRAFFIC ENGINEERING DIVISION

LOOP LEAD DUCT  
DETAIL

STANDARD DETAIL DRAWING 6.04

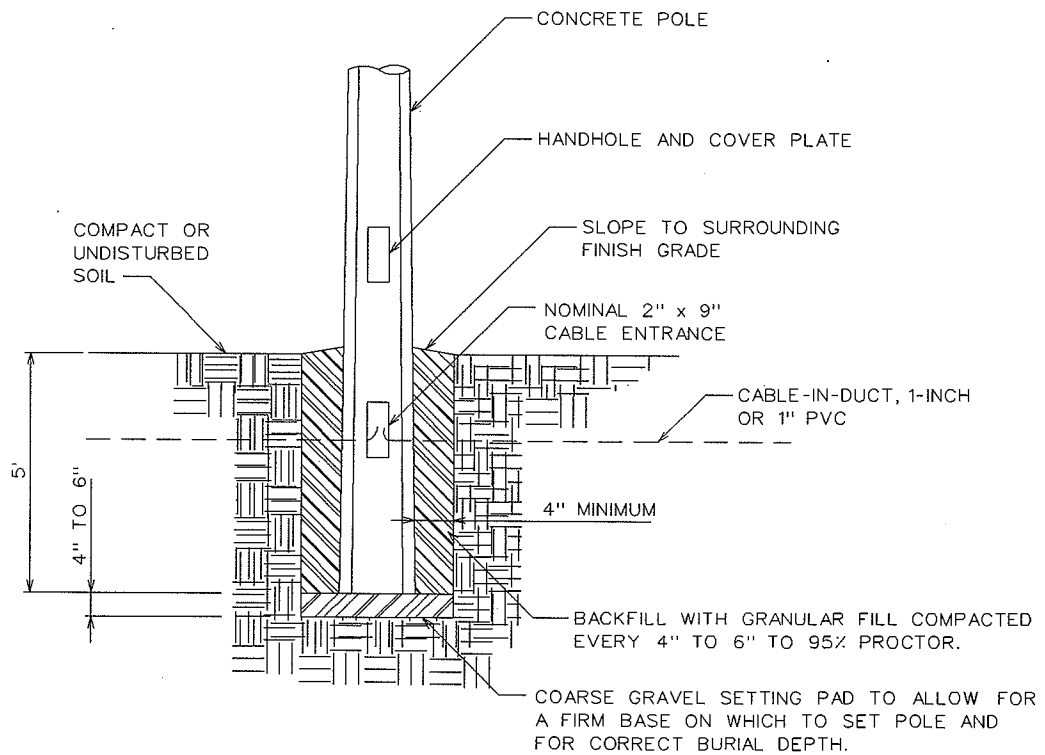

CONCRETE POLE BURIAL DETAIL

2004

CITY OF MADISON  
TRAFFIC ENGINEERING DIVISION

CONCRETE POLE BURIAL  
DETAIL

STANDARD DETAIL DRAWING 6.05

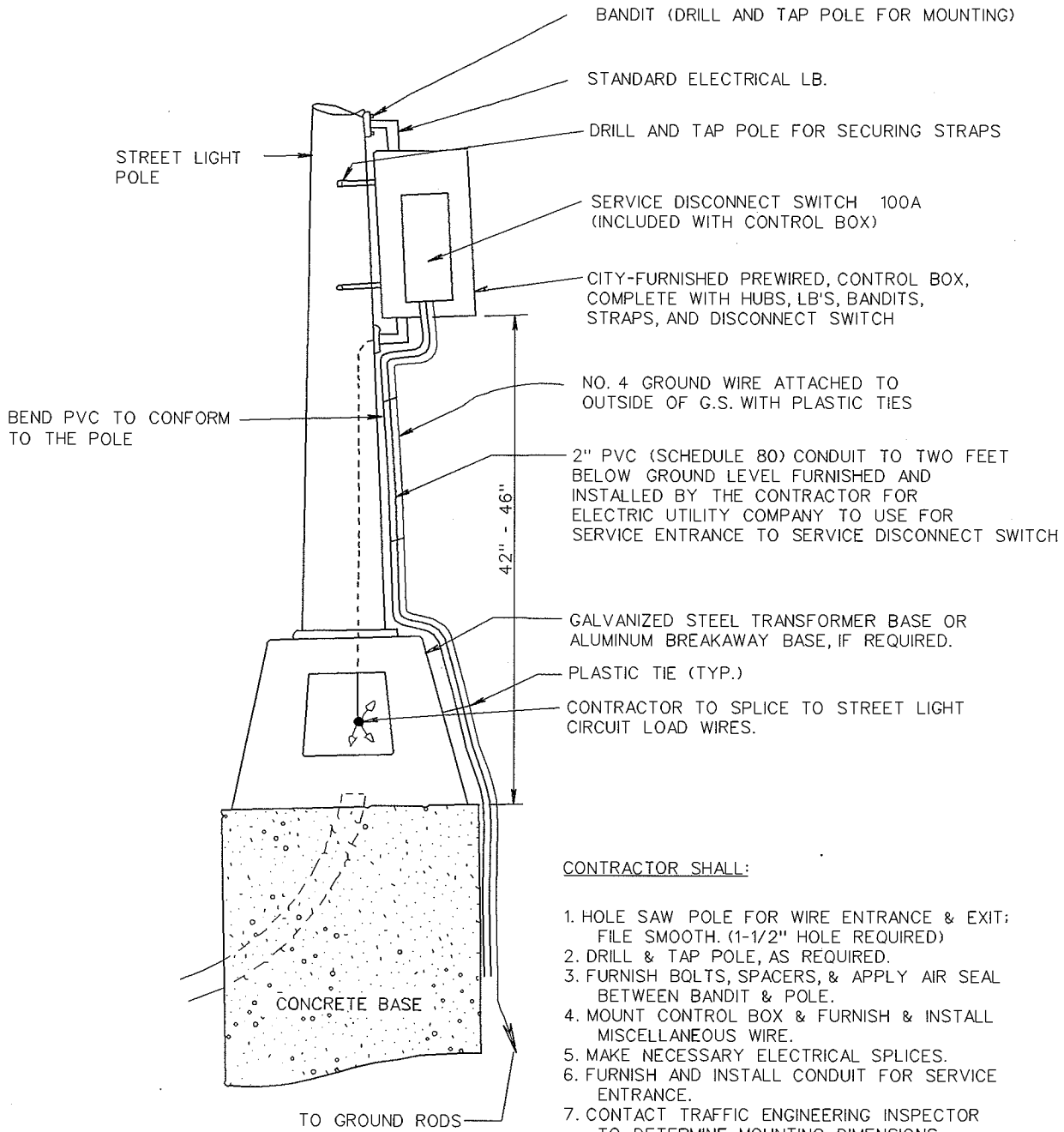

**CONTRACTOR SHALL:**

1. HOLE SAW POLE FOR WIRE ENTRANCE & EXIT; FILE SMOOTH. (1-1/2" HOLE REQUIRED)
2. DRILL & TAP POLE, AS REQUIRED.
3. FURNISH BOLTS, SPACERS, & APPLY AIR SEAL BETWEEN BANDIT & POLE.
4. MOUNT CONTROL BOX & FURNISH & INSTALL MISCELLANEOUS WIRE.
5. MAKE NECESSARY ELECTRICAL SPLICES.
6. FURNISH AND INSTALL CONDUIT FOR SERVICE ENTRANCE.
7. CONTACT TRAFFIC ENGINEERING INSPECTOR TO DETERMINE MOUNTING DIMENSIONS.
8. USE MACHINE TYPE BOLTS FOR MOUNTING.
9. MOUNT CONTROL BOX ON SIDEWALK SIDE OF POLE OR AS DIRECTED BY THE ENGINEER.
10. INSTALL GROUND RODS & GROUND WIRE

**NOTE:**

ALL WORK TO BE IN ACCORDANCE WITH SECTION 606 OF THE SPECIFICATIONS.

2004

CITY OF MADISON TRAFFIC ENGINEERING DIVISION
<b>POLE MOUNTED STREET LIGHT CONTROL PANEL</b>
STANDARD DETAIL DRAWING 6.06

CONTROL PANEL INSTALLED WITH DOOR FACING THE SIDEWALK

SERVICE DISCONNECT SWITCH, 100A

- NOTE:
1. CONTROL PANEL, DISCONNECT SWITCH, POST & METAL BASE FURNISHED BY THE CITY AS A COMPLETE UNIT.
  2. MOUNT UNIT ON BASE
  3. INSTALL GROUND RODS AND GROUND WIRES
  4. ALL WORK WITH SECTION ACCORDANCE WITH SECTION 606 OF THE SPECIFICATIONS

PLASTIC TIE (TYP.)

NO. 4 GROUND WIRE ATTACHED TO OUTSIDE OF GS WITH PLASTIC TIES

4" DIAMETER POST

2" PVC (SCHEDULE 80) CONDUIT FOR ELECTRICAL SERVICE (FURNISHED AND INSTALL BY THE CONTRACTOR)

CONNECT TO STREET LIGHT CIRCUIT LOAD WIRES IN METAL BASE

TRAFFIC SIGNAL METAL TYPE BASE

FINAL GRADE

TYPE "G" BASE CONSTRUCTED BY THE CONTRACTOR. PAID FOR AS TRAFFIC SIGNAL BASE.

24" MIN.

TO GROUND RODS

2004

CITY OF MADISON TRAFFIC ENGINEERING DIVISION
<b>PEDESTAL MOUNTED STREET LIGHT CONTROL PANEL</b>
STANDARD DETAIL DRAWING 6.07



TO UTILITY COMPANY  
POWER LINE

100 AMP DISCONNECT SWITCH  
MOUNTED ON OUTSIDE OF CABINET.

MAIN  
BREAKER

TIME  
CLOCK

MOTOR

NEUTRAL BAR (N)

SERVICE  
GROUND

ALL NIGHT  
CONTACTOR

MIDNIGHT  
CONTACTOR

FUSE

BLACK → 3#14 THHN  
N → STRANDED WIRES  
RED → TO PHOTO CONTROL

LOCATE PEC ON  
NEAREST LUMINAIRE

HAND-OFF-AUTO  
3 POSITION SWITCH

AN  
FIELD  
FEED  
PHASE A

AN  
FIELD  
FEED  
PHASE B

MN  
FIELD  
FEED  
PHASE A

MN  
FIELD  
FEED  
PHASE B

60 AMP AN CONTACTOR: 48 AMP MAX. LOAD  
30 AMP MN CONTACTOR: 24 AMP MAX. LOAD

60 AMP CONTACTOR FOR #6 WIRE  
100 AMP CONTACTOR FOR #4 WIRE

NOTE:

CONTRACTOR SHALL CONNECT CIRCUIT WIRING IN SUCH A MANNER TO BALANCE THE LOAD BETWEEN PHASE A AND B AS CLOSE AS POSSIBLE AND AS DIRECTED BY THE ENGINEER.

2004

CITY OF MADISON TRAFFIC ENGINEERING DIVISION
120V STREET LIGHT CONTROL PANEL ELECTRICAL SERVICE DETAIL
STANDARD DETAIL DRAWING 6.08

# CONDUIT PLACEMENT DETAILS FOR COMMERCIAL DRIVE APPROACHES

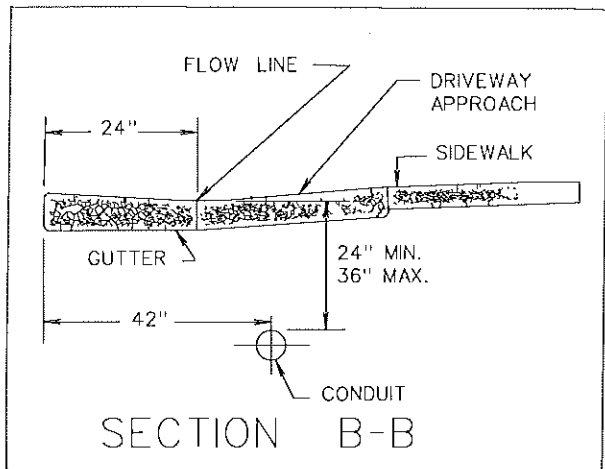
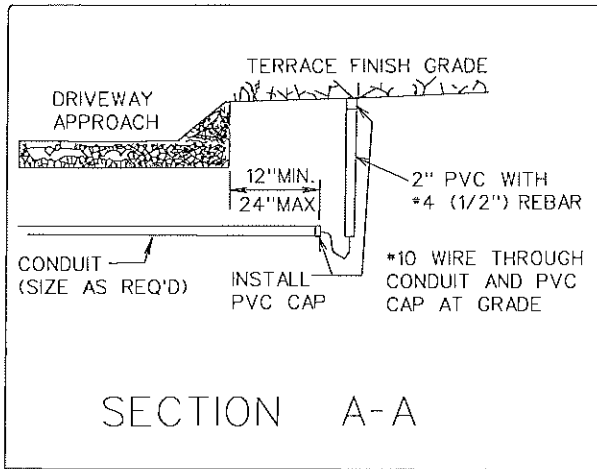
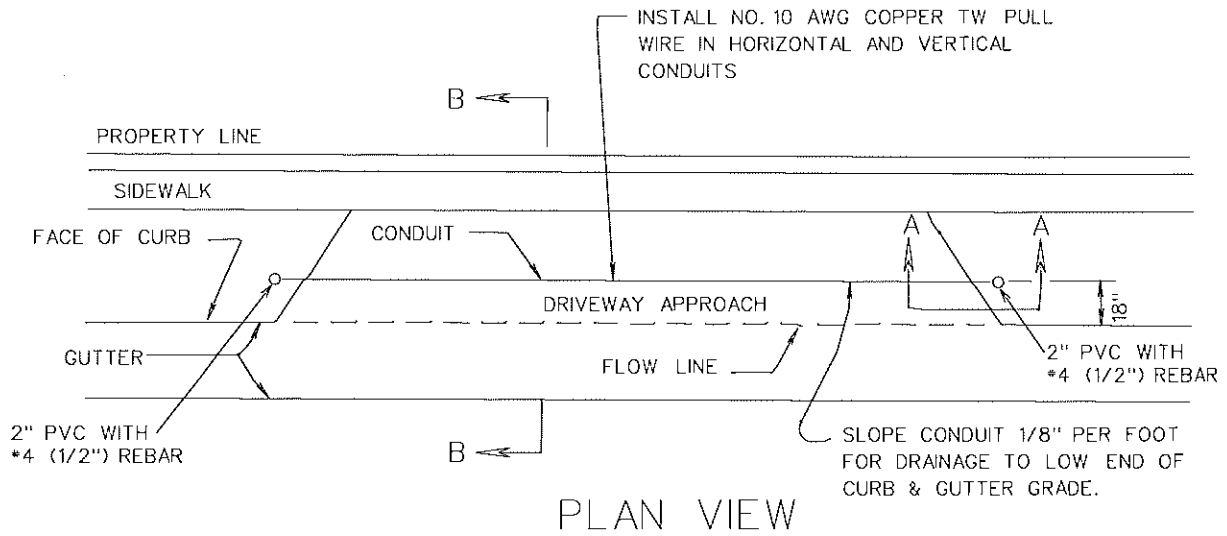

BEFORE CONSTRUCTION, THE CONTRACTOR SHALL CONTACT THE TRAFFIC ENGINEERING SHOP, ELECTRICAL SECTION, (608-266-4767) TO ARRANGE FOR INSPECTION OF THE DUCT PLACEMENT.

2013

CITY OF MADISON TRAFFIC ENGINEERING DIVISION
CONDUIT PLACEMENT DETAILS FOR COMMERCIAL DRIVE APPROACH
STANDARD DETAIL DRAWING 6.09

CONTROL CABINET BASE TYPE	DIMENSIONS				C.Y. CONCRETE (APPROX.)
	L	W	J	K	
TYPE M	40"	30"	12"	20"	.823
TYPE P	48"	30"	16"	24"	1.179
TYPE M MODIFIED	-	-	-	-	-
TYPE P MODIFIED	-	-	-	-	-
TYPE OTHER	-	-	-	-	-

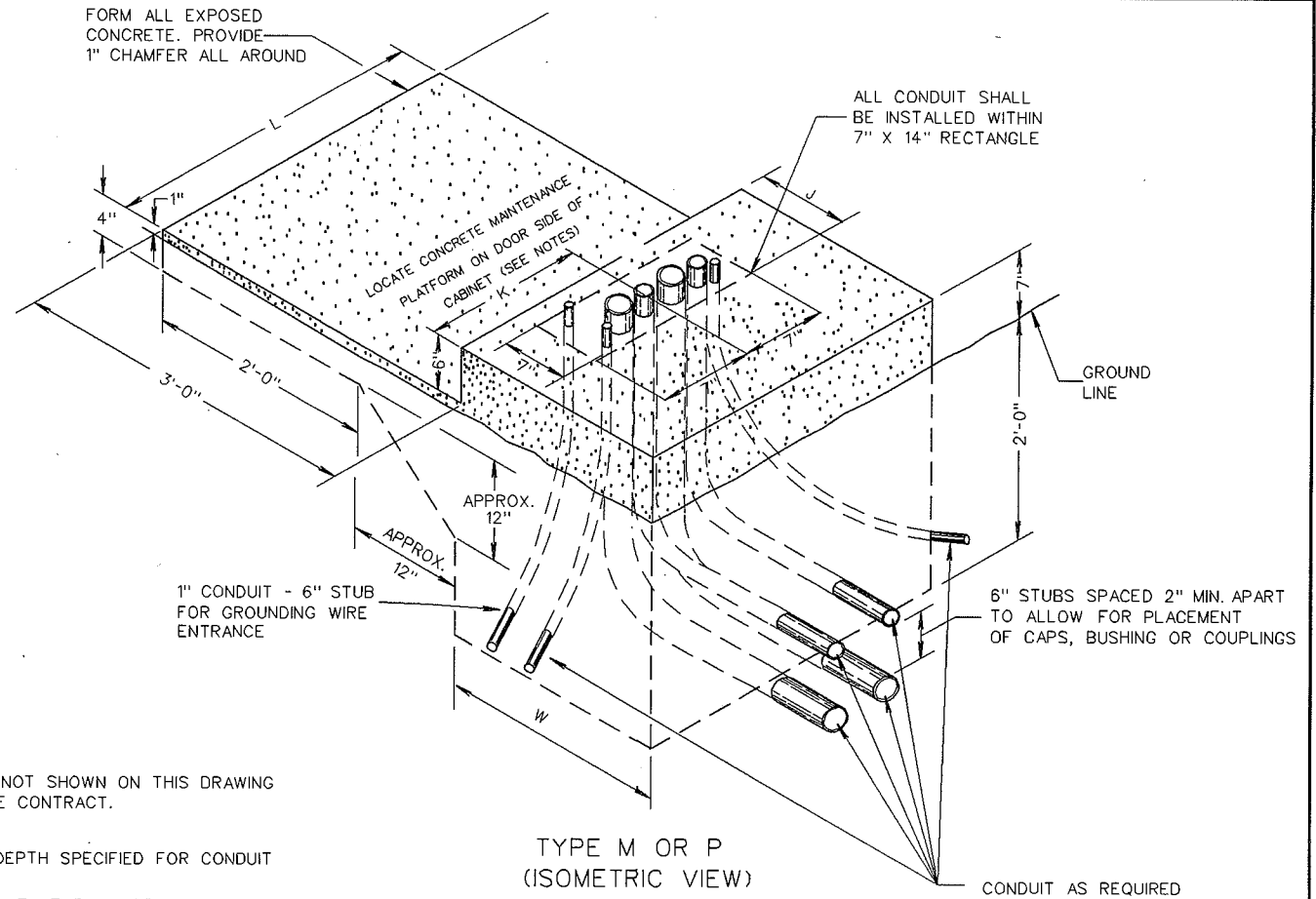

## GENERAL NOTES

DETAILS OF CONSTRUCTION, MATERIALS AND WORKMANSHIP NOT SHOWN ON THIS DRAWING SHALL CONFORM TO THE PERTINENT REQUIREMENTS OF THE CONTRACT.

ALL CONDUIT SHALL BE PVC, SCHEDULE 40

DEPTH OF CONDUIT EXITING THE BASE SHALL MATCH THE DEPTH SPECIFIED FOR CONDUIT INSTALLATION.

ANY EXCEPTION TO THE MAXIMUM DEPTH SHALL BE ONLY WITH THE WRITTEN APPROVAL OF THE ENGINEER.

CONTROL CABINET BASE TOP SURFACES SHALL BE TROWEL FINISHED AND LEVEL.

MAINTENANCE PLATFORM SHALL NOT BE INSTALLED WHEN THE SURROUNDING AREA IS PAVED.

MINIMUM BENDING RADIUS OF CONDUIT - 6 X THE DIAMETER.

ALL CONDUIT ENDS AT THE TOP OF CONCRETE BASES SHALL BE CAPPED OR PLUGGED IMMEDIATELY AFTER PLACEMENT AND BEFORE CONCRETE IS POURED. CONDUITS IN WHICH WIRE OR CABLE IS NOT BEING INSTALLED SHALL REMAIN CAPPED OR PLUGGED.

CONCRETE FORM DEPTH BELOW FINISHED GRADE SHALL BE 6" MINIMUM. CONCRETE FORMS SHALL BE REMOVED AFTER CONCRETE HAS SET.

CONDUITS SHALL EXIT THE BASE IN THE DIRECTION OF THE STRUCTURE IT IS TERMINATING INTO.

MAINTENANCE PLATFORM SIZE MAY VARY ON ACCOUNT OF CONDITIONS. VERIFY THE MAINTENANCE PLATFORM SIZE WITH ENGINEER PRIOR TO POURING BASE.

## CONCRETE CONTROL CABINET BASES

2004

CITY OF MADISON  
TRAFFIC ENGINEERING DIVISION

TYPE "M" AND "P"  
CONTROLLER BASE DETAIL

STANDARD DETAIL DRAWING 6.10

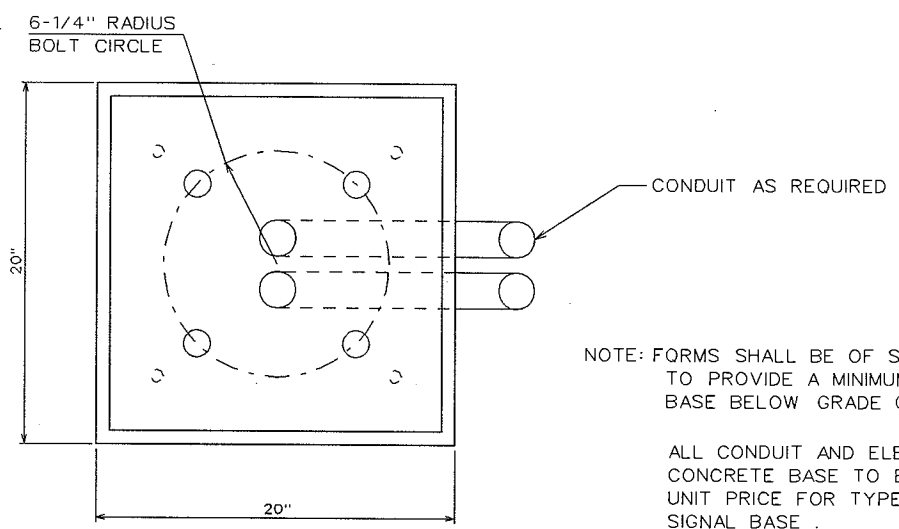

NOTE: FORMS SHALL BE OF SUFFICIENT DEPTH TO PROVIDE A MINIMUM OF 12" OF FORMED BASE BELOW GRADE ON THE LOW SIDE.

ALL CONDUIT AND ELBOWS SHOWN IN CONCRETE BASE TO BE INCLUDED IN UNIT PRICE FOR TYPE "G" TRAFFIC SIGNAL BASE .

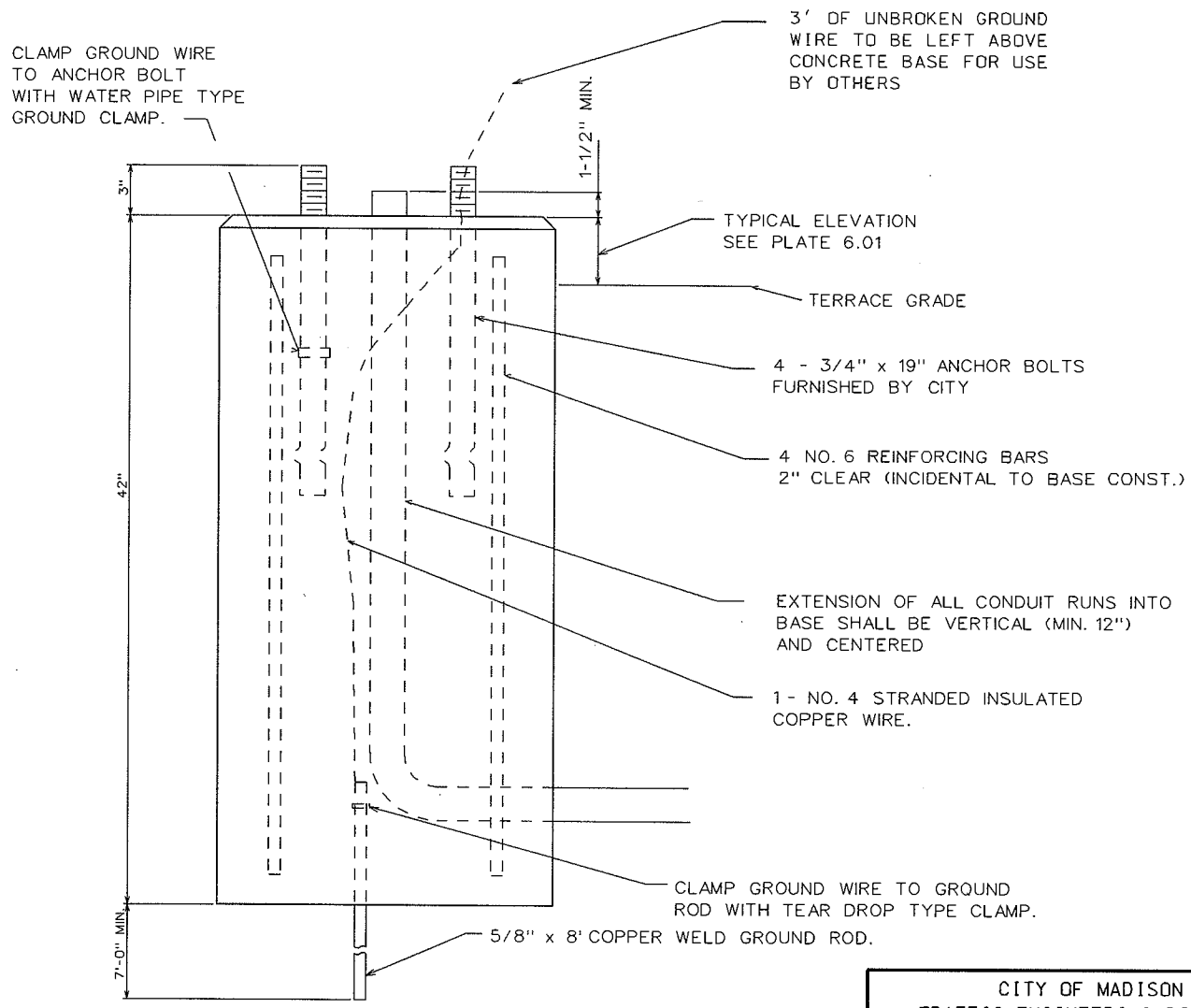

2004

CITY OF MADISON TRAFFIC ENGINEERING DIVISION
<b>TYPE "G" BASE DETAIL</b>
STANDARD DETAIL DRAWING 6.11

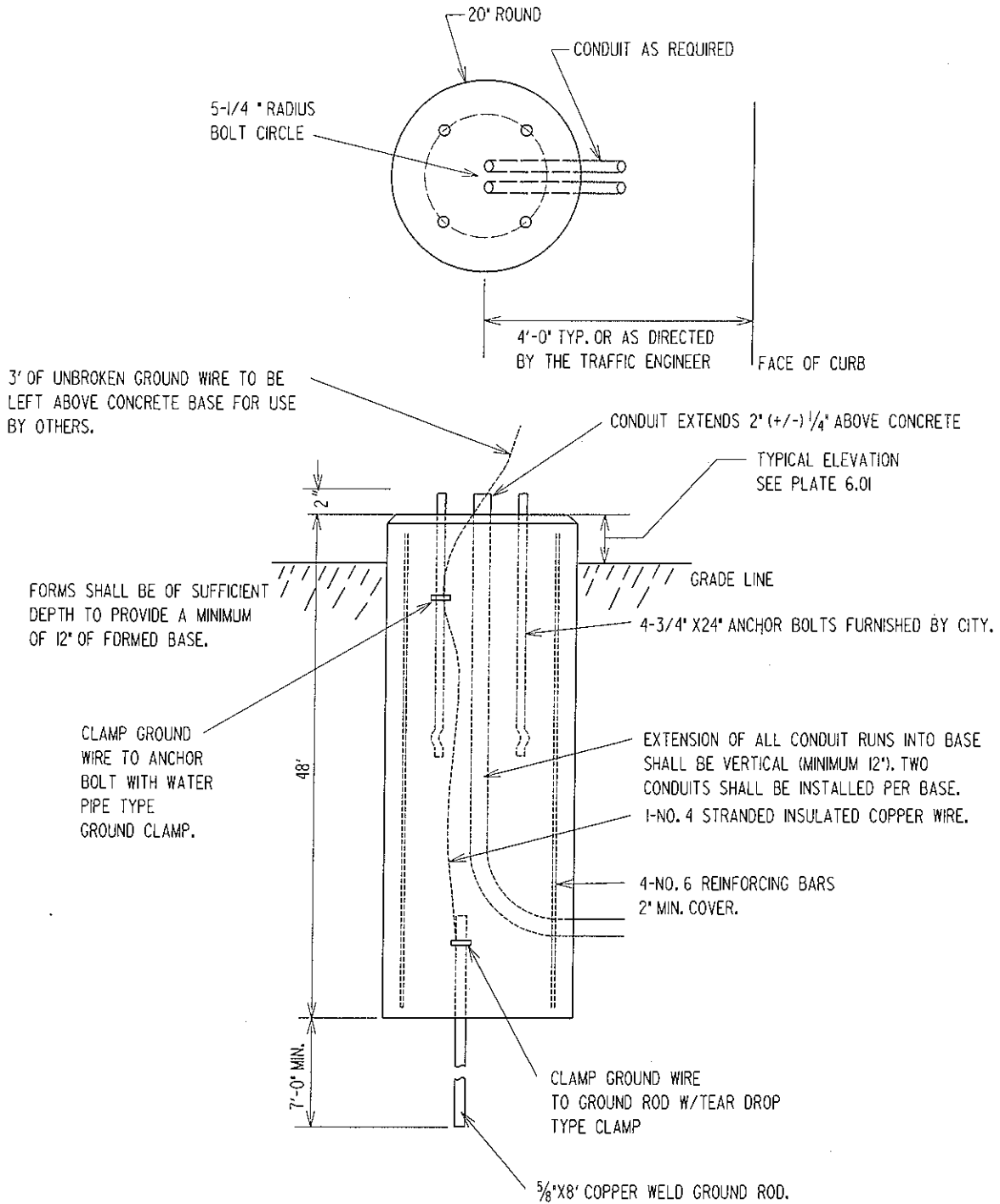

2009

CITY OF MADISON TRAFFIC ENGINEERING DIVISION
LB-1 BASE DETAIL
STANDARD DETAIL DRAWING 6.12

\* TOP 12" OF FORMED BASE TO BE ROUND,  
16" DIAMETER AS SHOWN, OR DIRECTED BY THE ENGINEER.

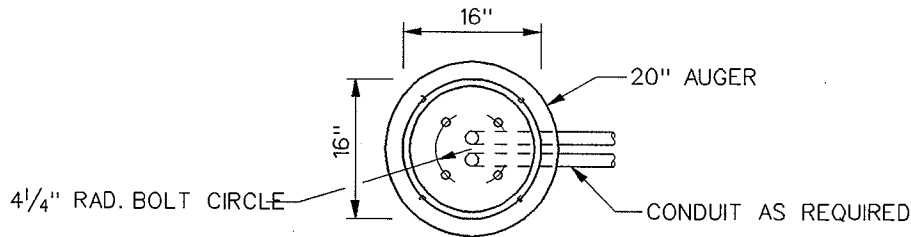

PLAN

TYPICAL ELEVATION  
SEE PLATE 6.01

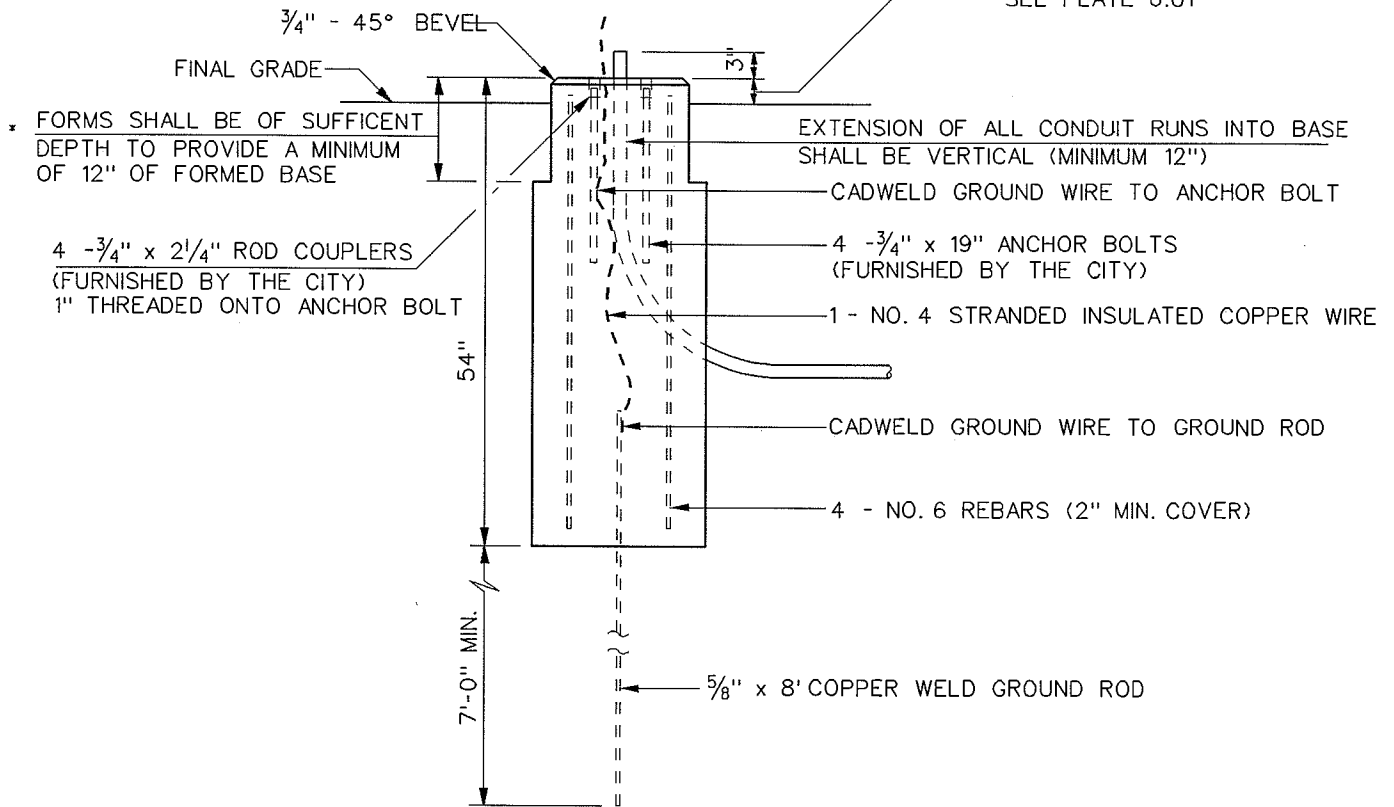

ELEVATION

NOTES:

RUST, CORROSION AND ANTI-SEIZE PROTECTION SHALL PROVIDED AT ALL THREADED ASSEMBLIES.

ROD COUPLERS SHALL BE SET FLUSH WITH TOP OF BASE.

2004

CITY OF MADISON  
TRAFFIC ENGINEERING DIVISION

LB-2  
BASE DETAIL

STANDARD DETAIL DRAWING 6.13

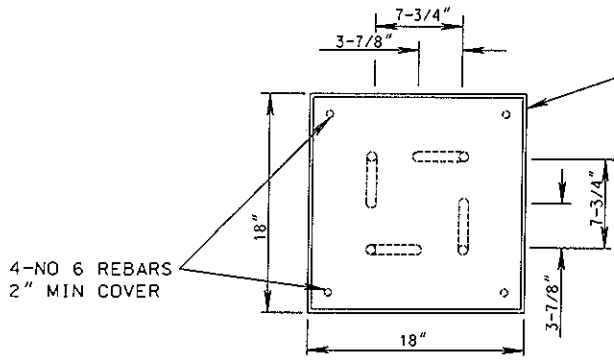

HOLE FOR BASE MAY BE DUG WITH 20" DIAMETER AUGER. THEN THE TOP SHALL BE FORMED AS A SQUARE.

4-NO 6 REBARS  
2" MIN COVER

3' OF UNBROKEN GROUND WIRE TO BE LEFT ABOVE CONCRETE BASE FOR USE BY OTHERS

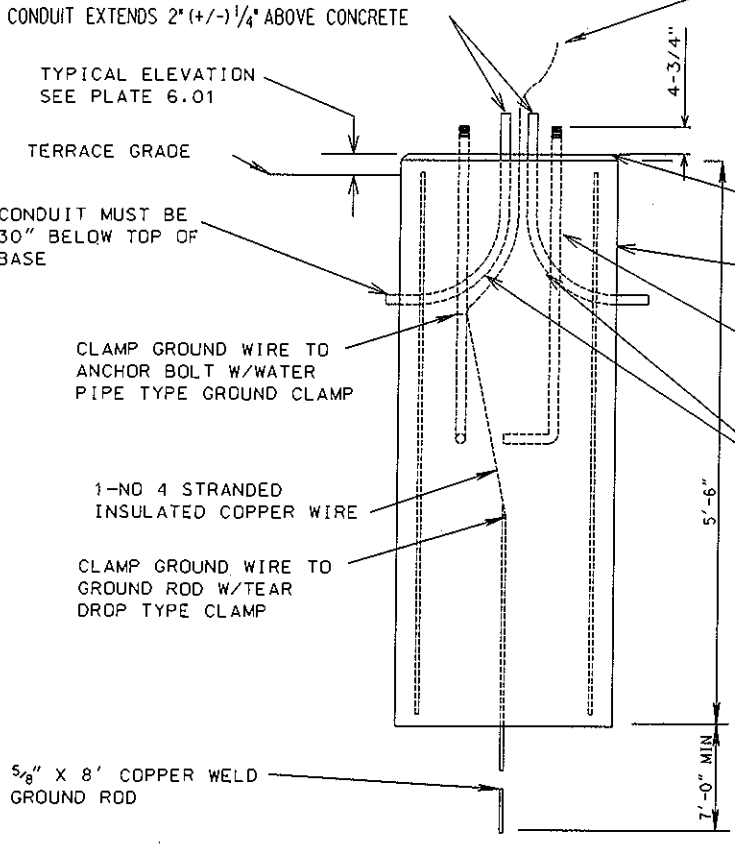

CONDUIT EXTENDS 2" (+/-) 1/4" ABOVE CONCRETE

TYPICAL ELEVATION  
SEE PLATE 6.01

TERRACE GRADE

CONDUIT MUST BE 30" BELOW TOP OF BASE

CLAMP GROUND WIRE TO ANCHOR BOLT W/WATER PIPE TYPE GROUND CLAMP

1-NO 4 STRANDED INSULATED COPPER WIRE

CLAMP GROUND WIRE TO GROUND ROD W/TEAR DROP TYPE CLAMP

5/8" X 8' COPPER WELD GROUND ROD

3/4" - 45° BEVEL

FORMS SHALL BE OF SUFFICIENT DEPTH TO PROVIDE A MINIMUM OF 12" OF FORMED BASE BELOW GRADE ON LOW SIDE

1" X 40" ANCHOR BOLTS WITH 6" OF THREAD AT TOP AND 4" L-BEND AT BOTTOM. FURNISHED BY CITY.

INSTALL PVC ELBOWS OUT OF EACH SIDE OF THE BASE AS NEEDED

ANCHOR BOLT CAGE DETAIL

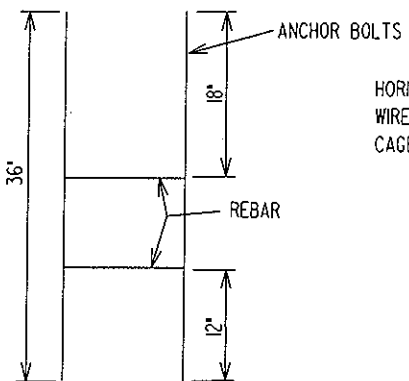

HORIZONTAL REBAR SHALL BE TACK WELDED OR WIRED TO ANCHOR BOLTS TO FORM ANCHOR BOLT CAGE BEFORE POURING CONCRETE.

2009

CITY OF MADISON TRAFFIC ENGINEERING DIVISION
LB-3 BASE DETAIL
STANDARD DETAIL DRAWING 6.14

**ANCHOR BOLT CAGE DETAIL**

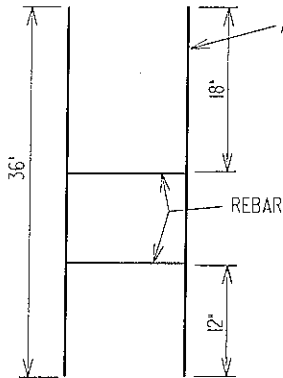

HORIZONTAL REBAR SHALL BE TACK WELDED OR WIRED TO ANCHOR BOLTS TO FORM ANCHOR BOLT CAGE BEFORE POURING CONCRETE.

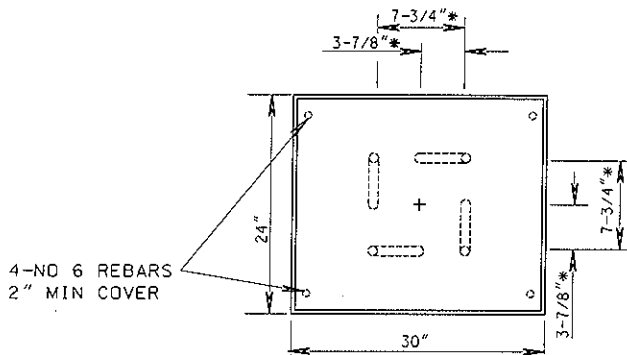

\*IF 15" BOLT CIRCLE IS REQUIRED INSTEAD OF THE 11" BOLT CIRCLE SHOWN THE FOLLOWING DIMENSIONS SHOULD BE USED:

CENTER TO BOLT 5-1/4"  
BOLT TO BOLT 10-1/2"

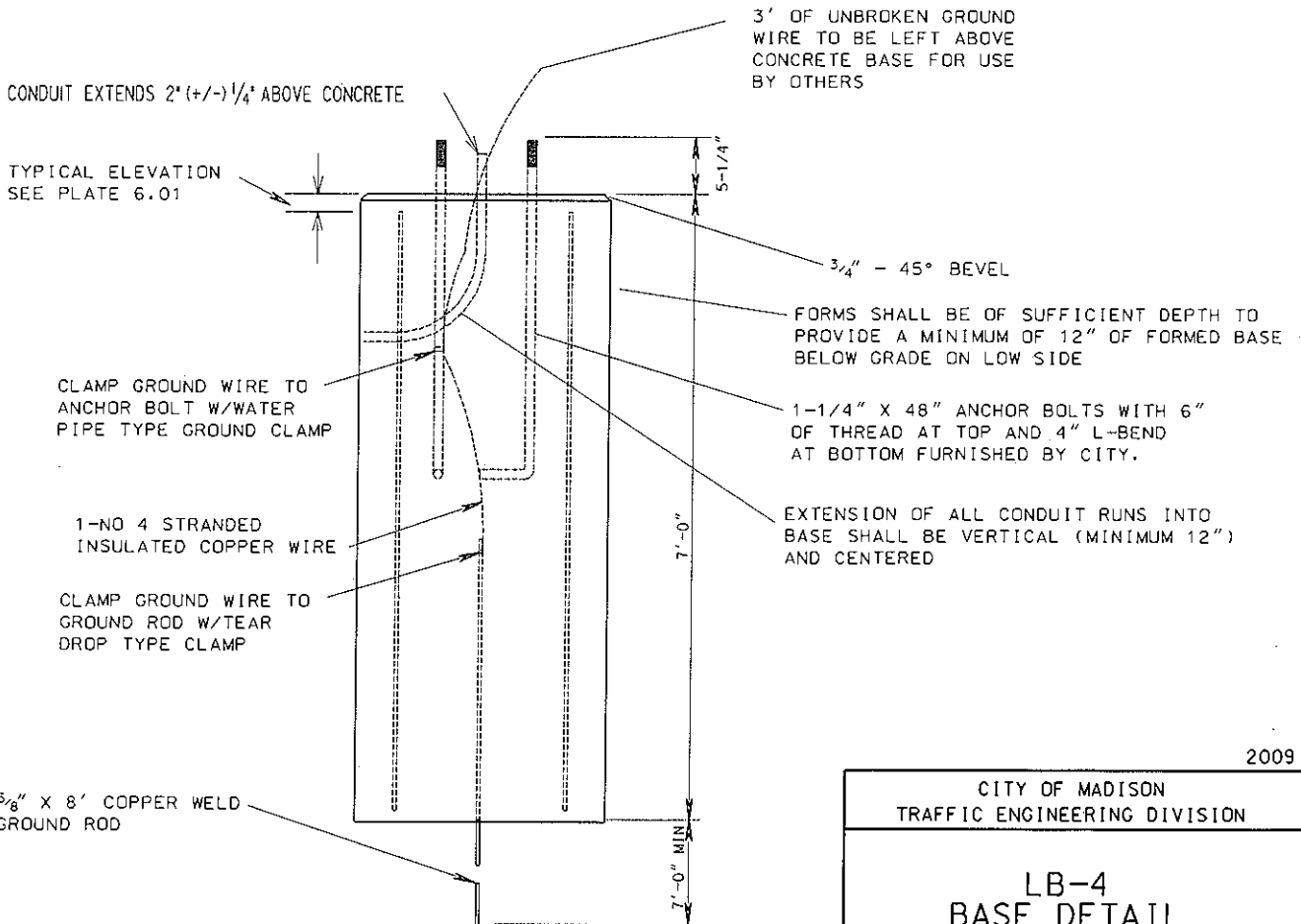

2009

CITY OF MADISON TRAFFIC ENGINEERING DIVISION
<b>LB-4 BASE DETAIL</b>
STANDARD DETAIL DRAWING 6.15



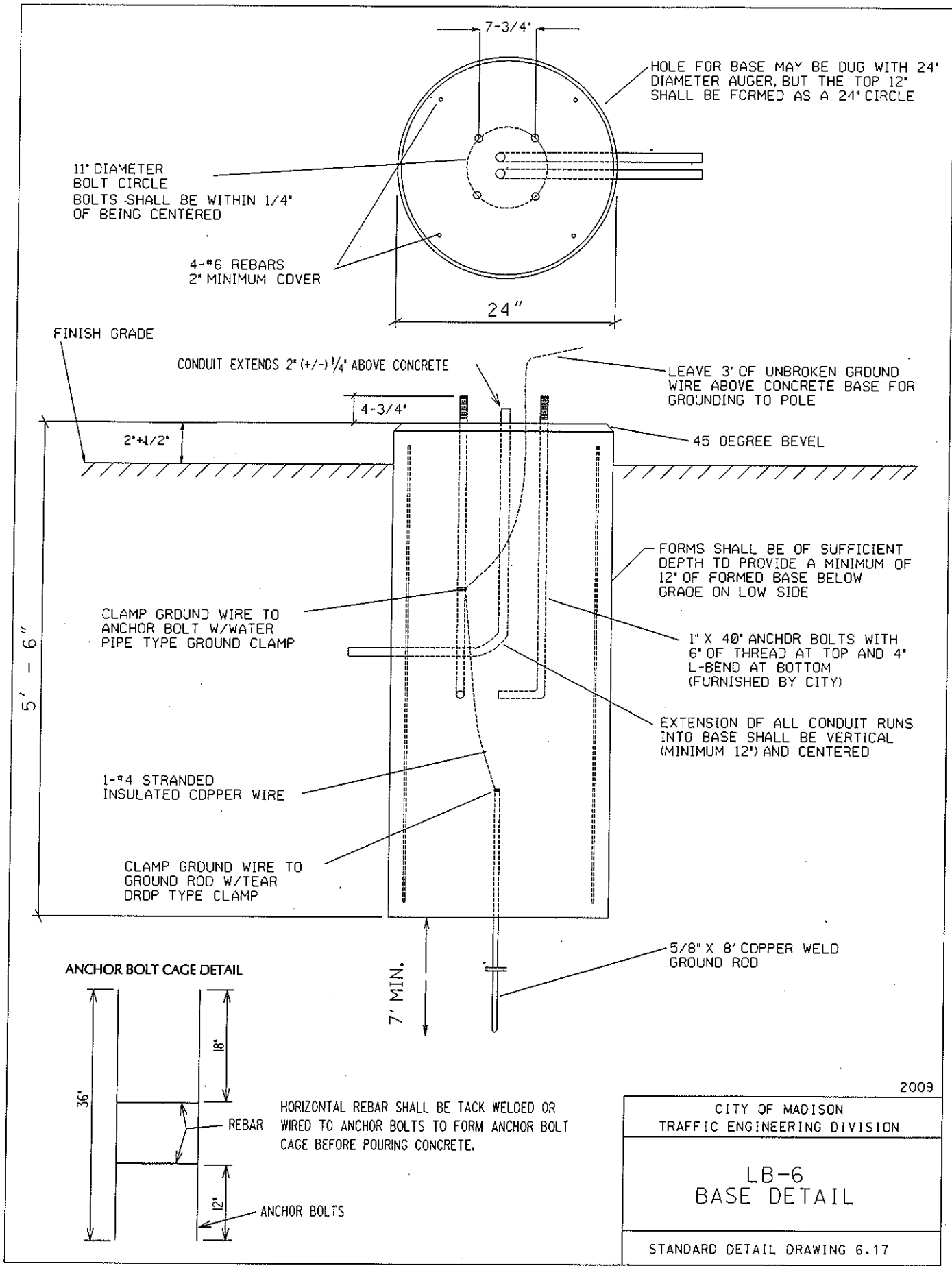

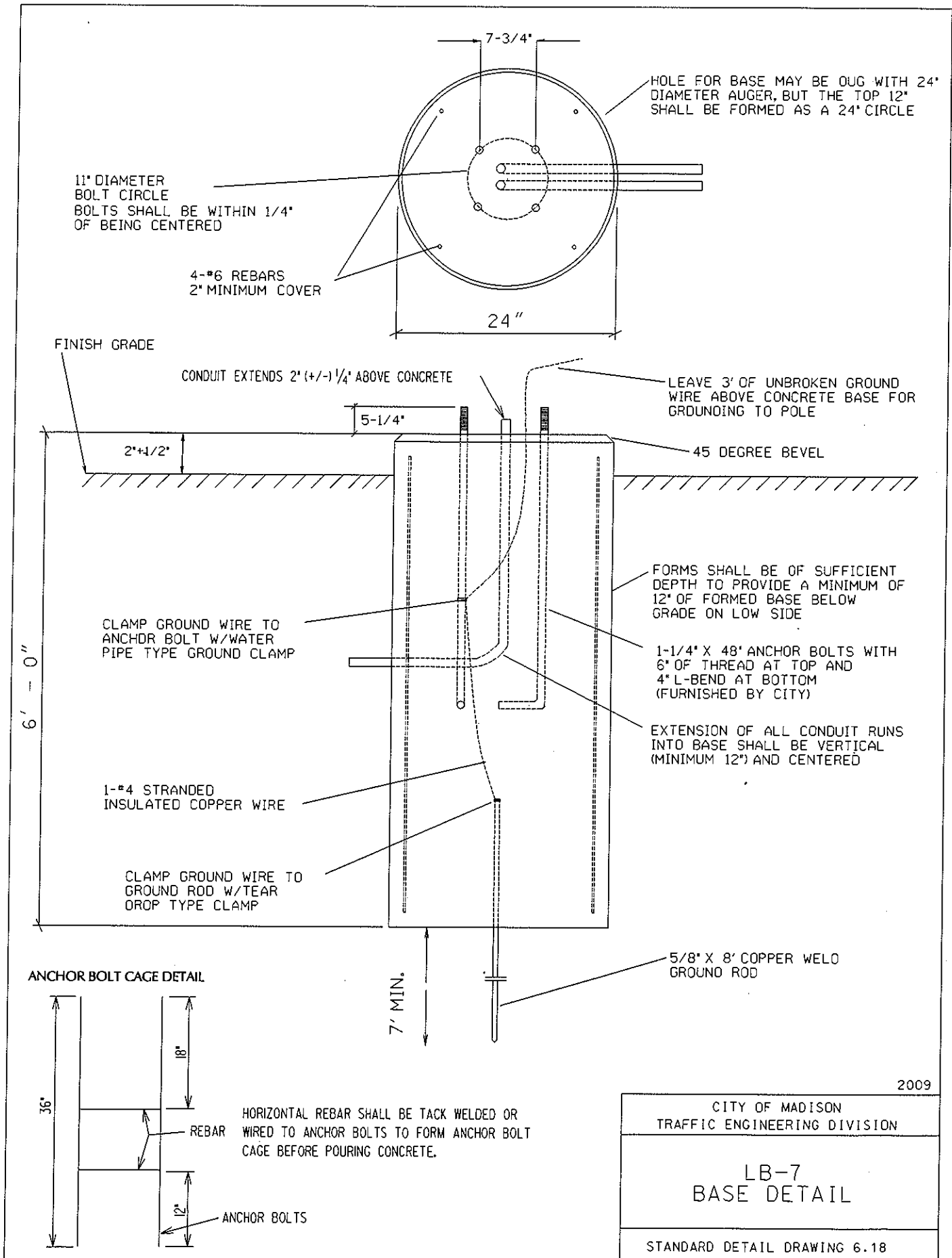



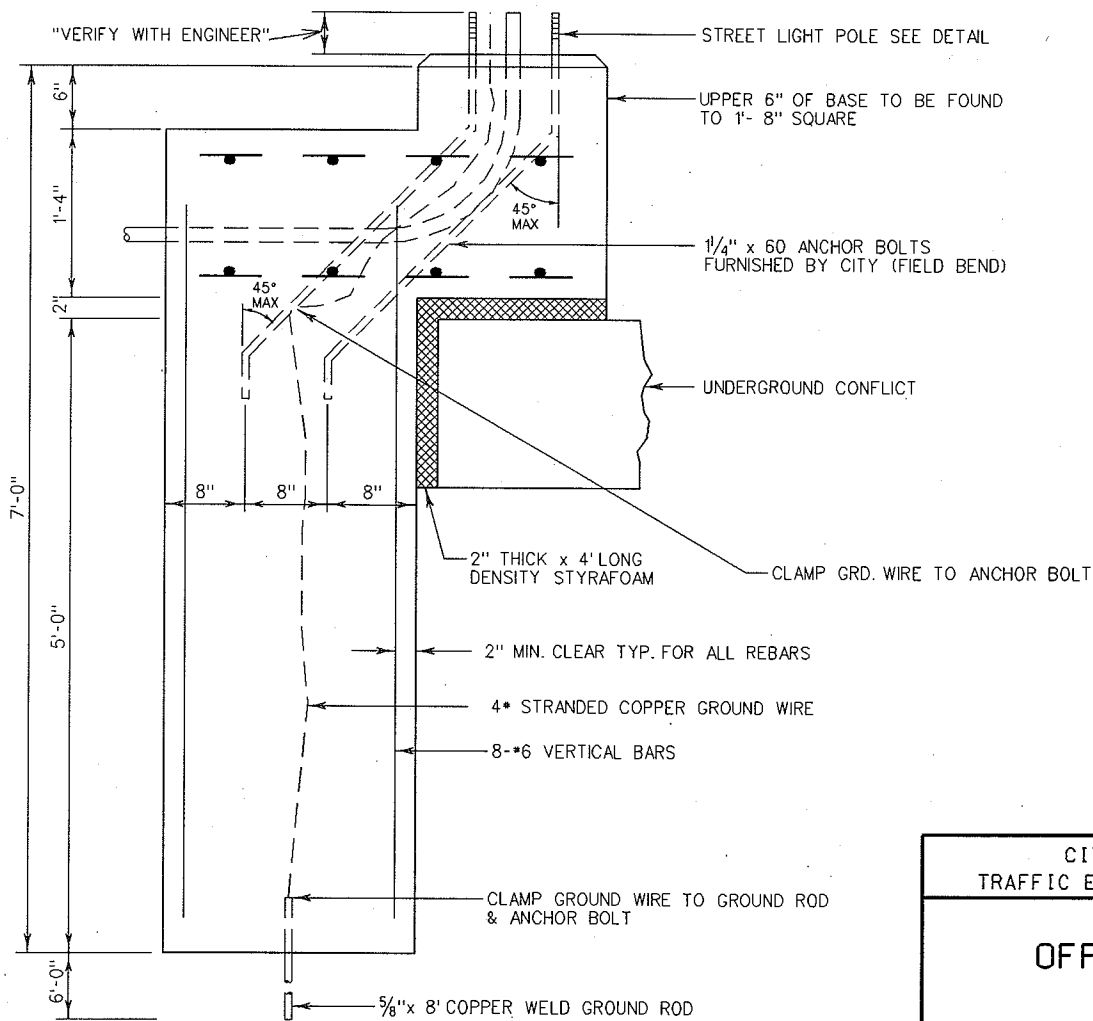
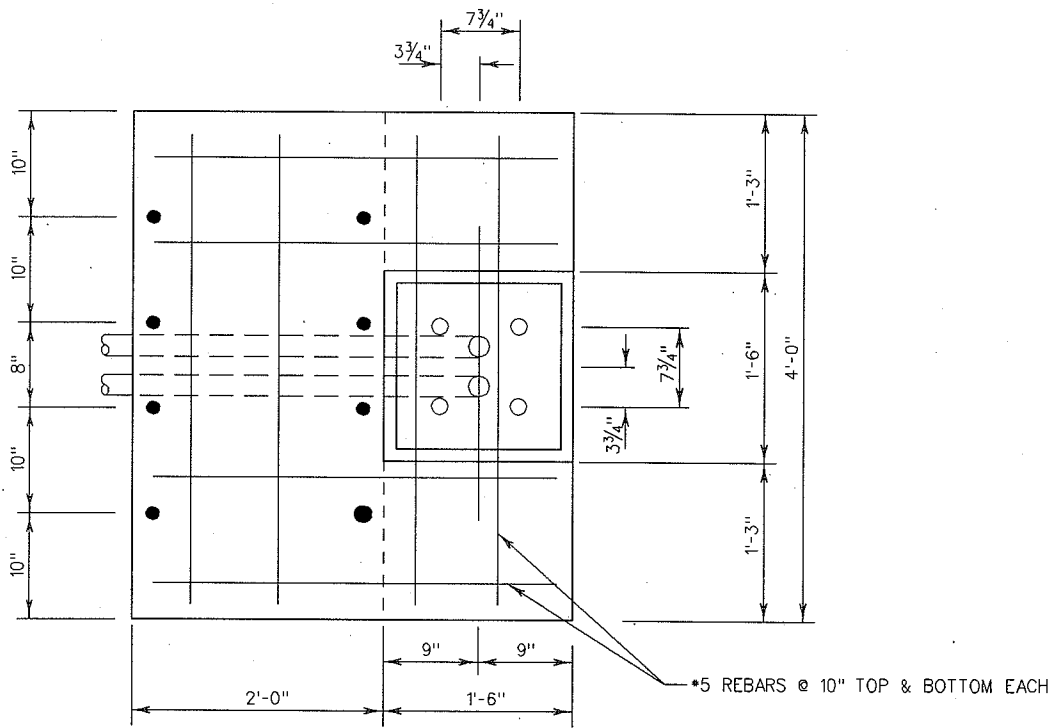

2004

CITY OF MADISON  
TRAFFIC ENGINEERING DIVISION

OFFSET BASE  
DETAIL

STANDARD DETAIL DRAWING 6.20

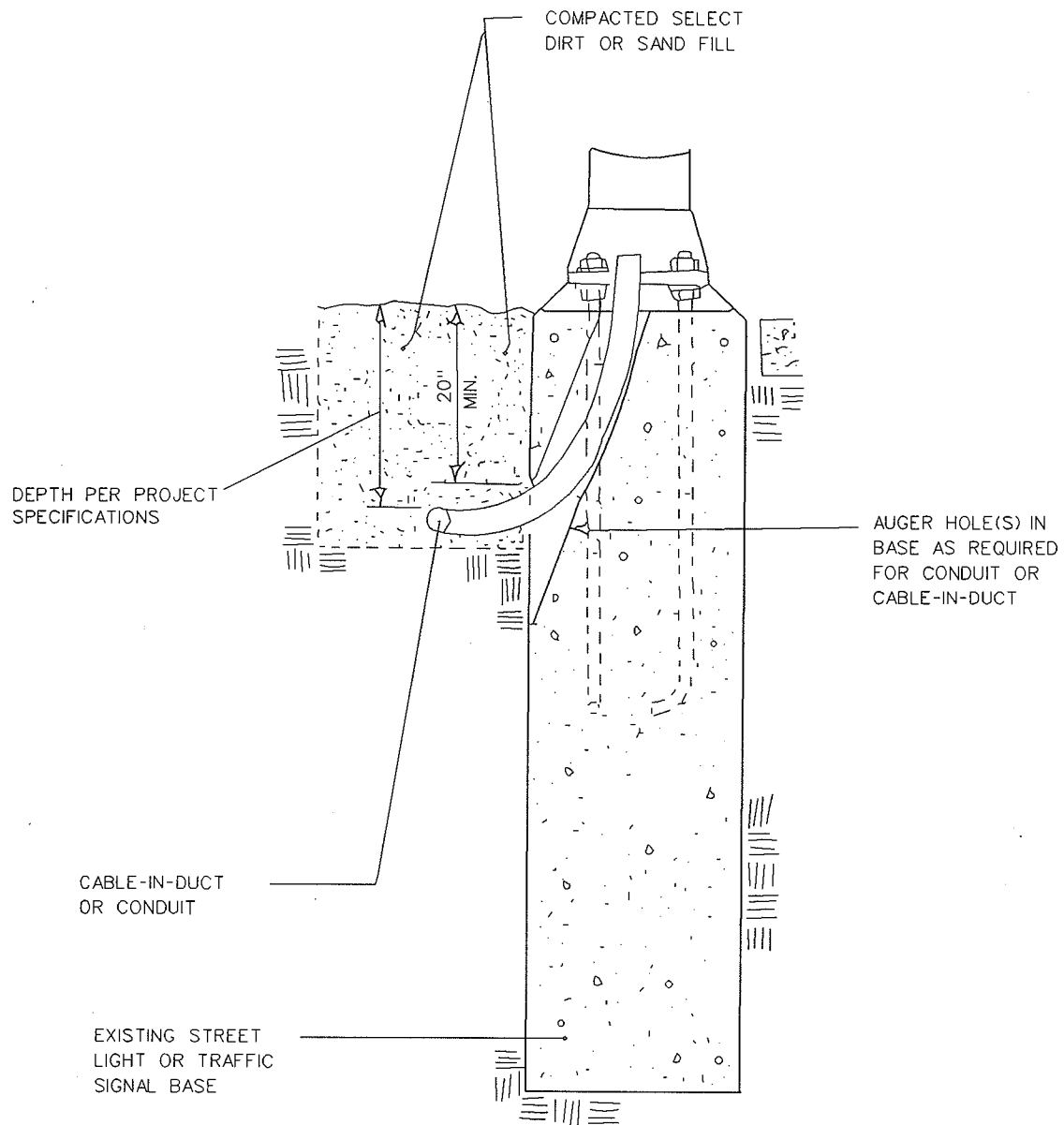

2004

CITY OF MADISON  
TRAFFIC ENGINEERING DIVISION

TYPICAL DETAIL FOR  
AUGERING A HOLE(S)  
IN EXISTING BASE FOR  
DUCT ENTRANCE

STANDARD DETAIL DRAWING 6.21

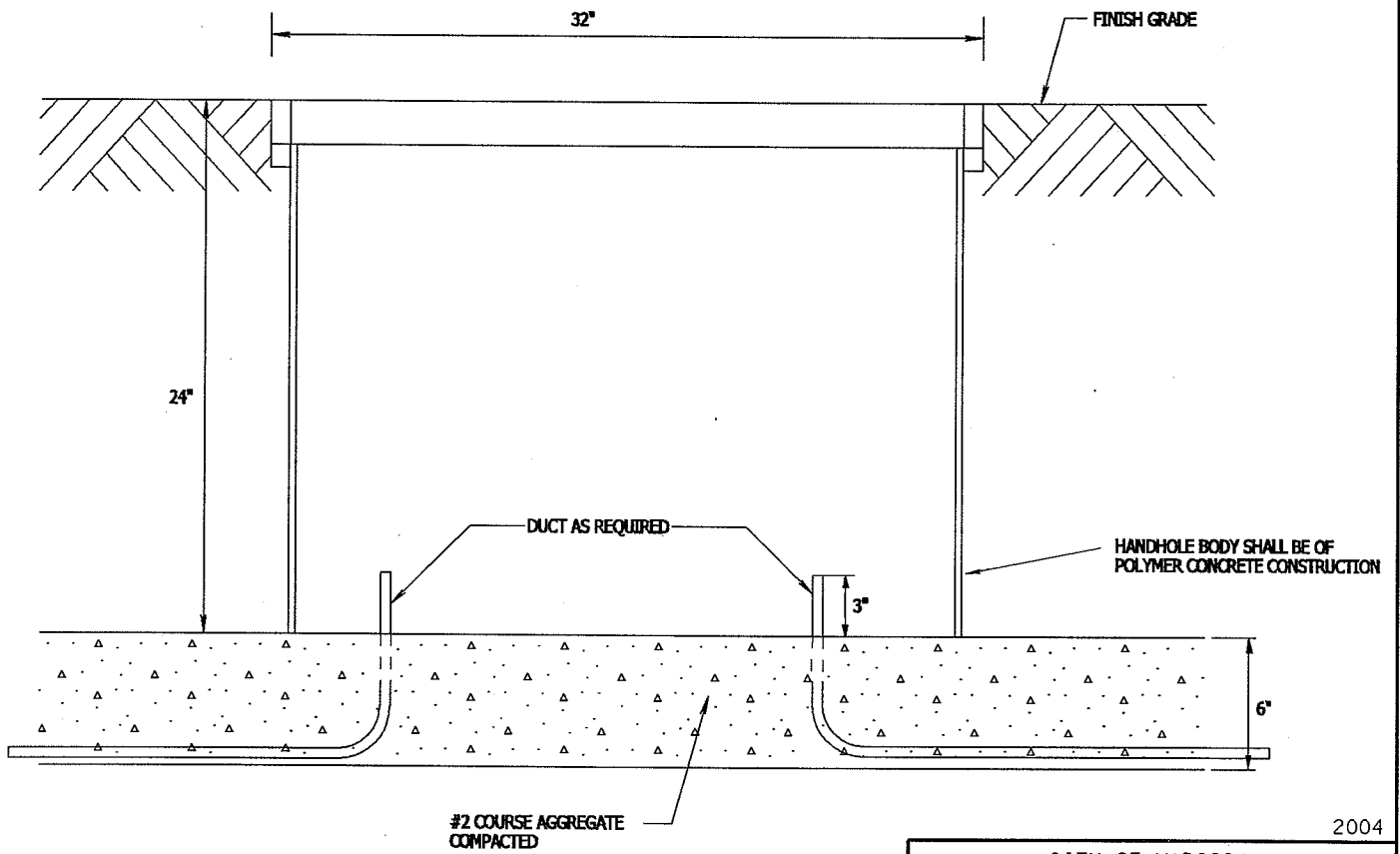
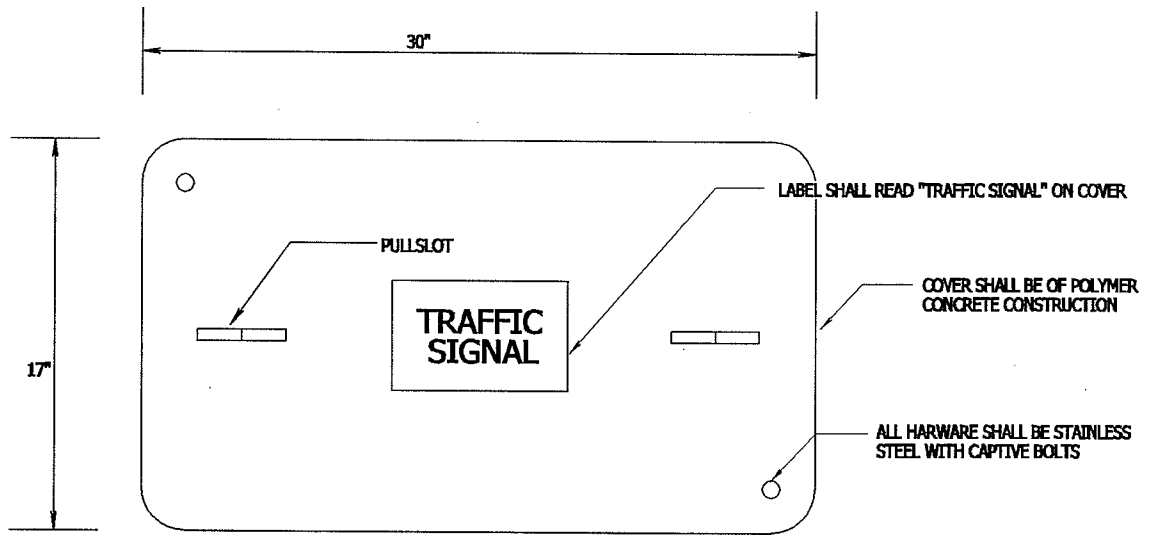

2004

CITY OF MADISON  
TRAFFIC ENGINEERING DIVISION

TYPE I HANDHOLE  
DETAIL

STANDARD DETAIL DRAWING 6.22

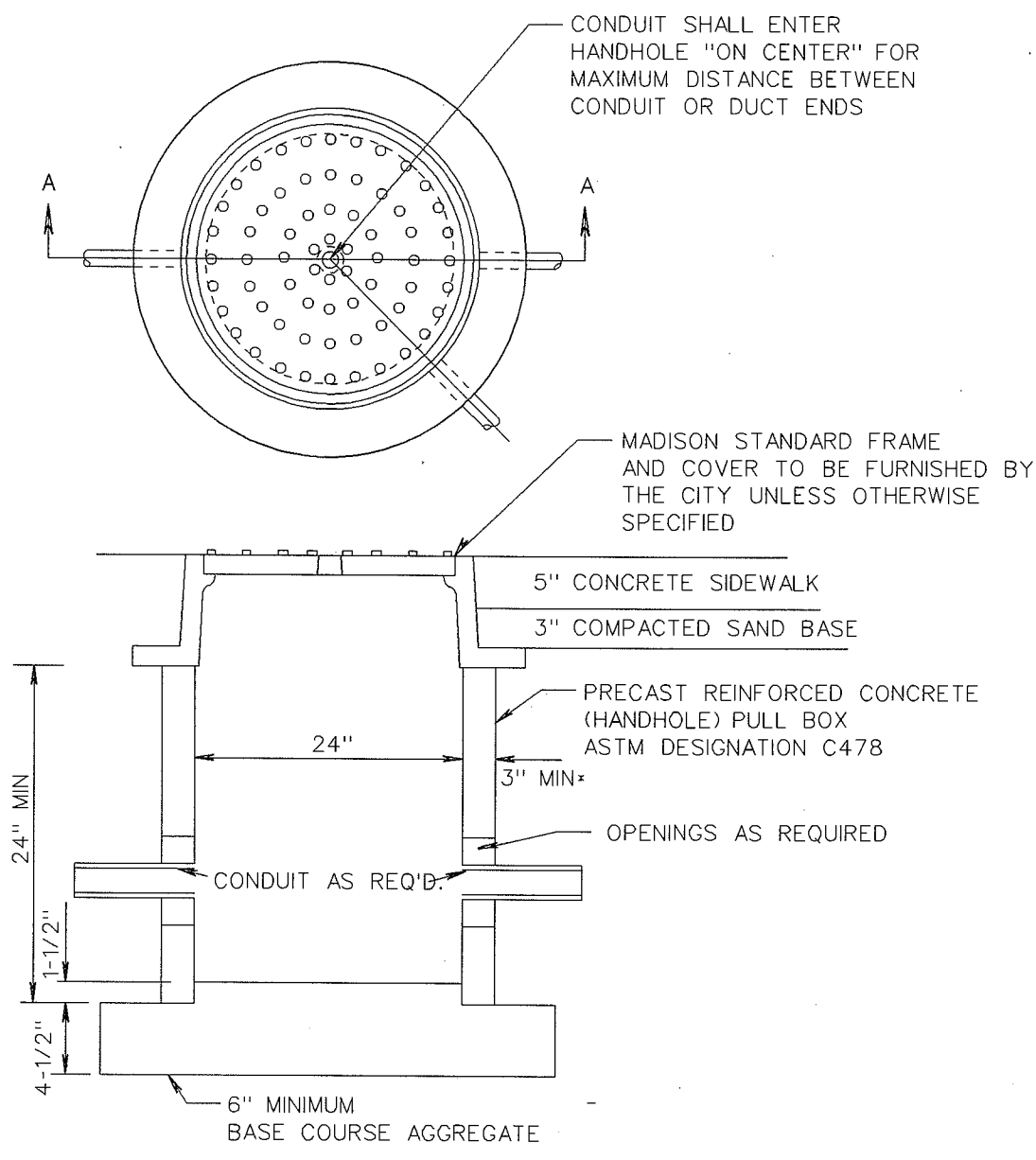

SECTION A-A

\*5" WALL THICKNESS IS REQUIRED IF HANDHOLE IS LOCATED IN ROADWAY OR DRIVEWAY APRON.

2004
CITY OF MADISON TRAFFIC ENGINEERING DIVISION
<b>TYPE II HANDHOLE DETAIL</b>
STANDARD DETAIL DRAWING 6.23

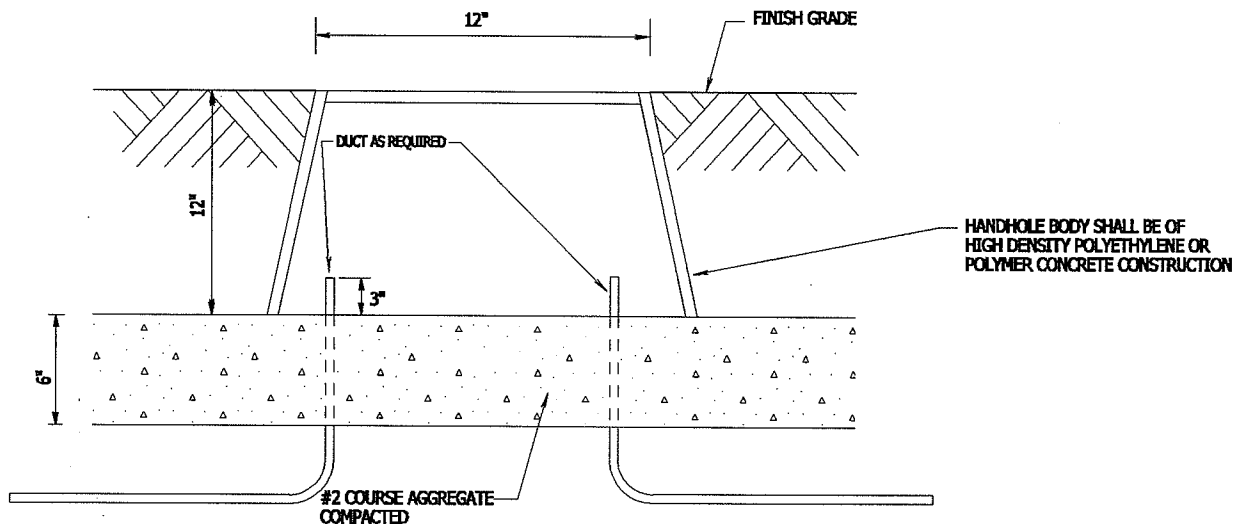
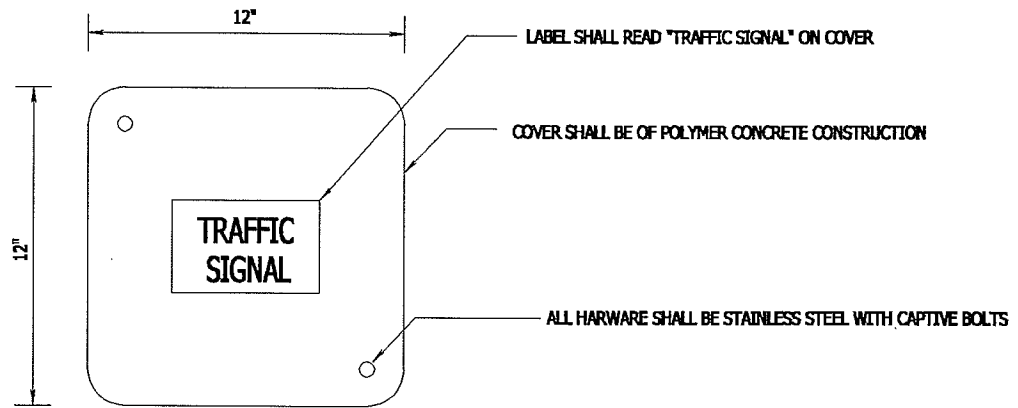

2004

CITY OF MADISON  
TRAFFIC ENGINEERING DIVISION

TYPE III HANDHOLE  
DETAIL

STANDARD DETAIL DRAWING 6.24



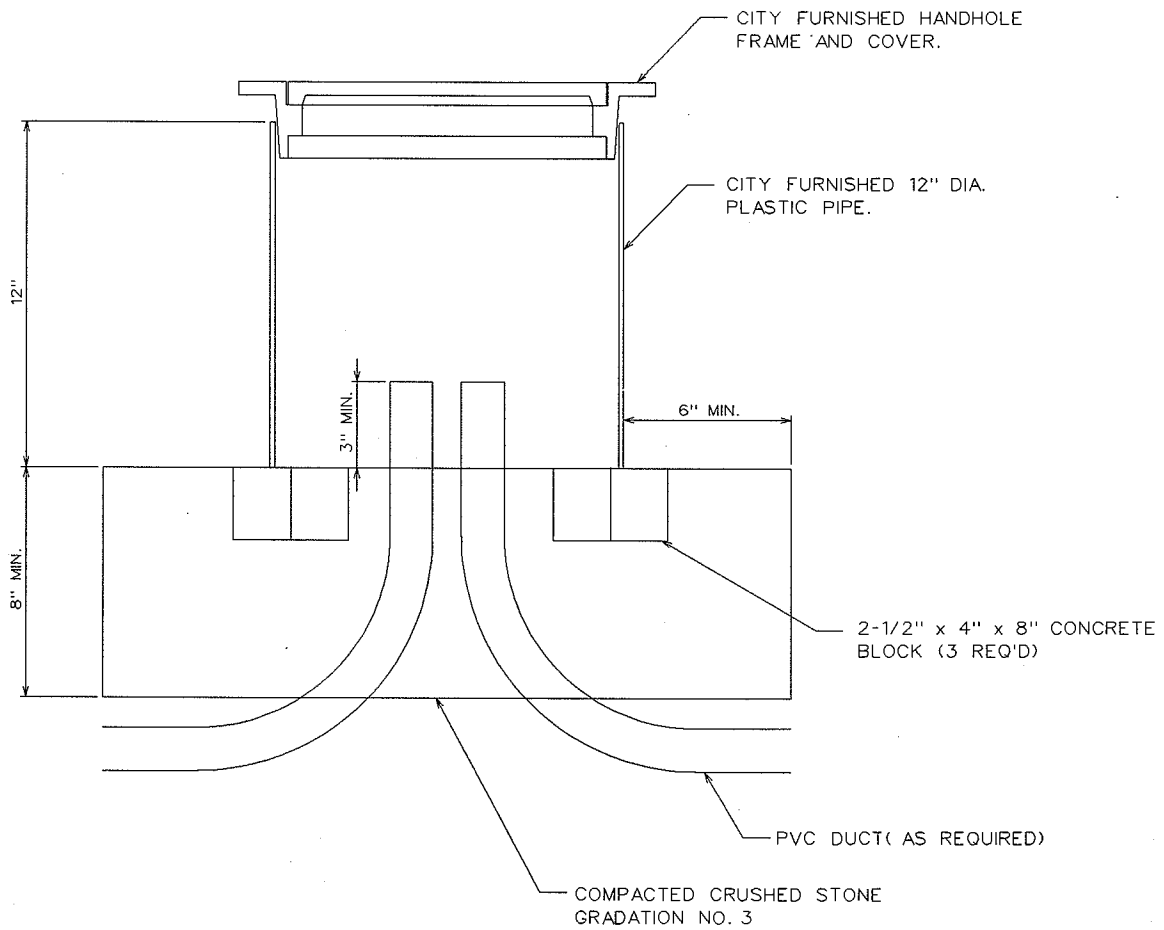

2004

CITY OF MADISON  
TRAFFIC ENGINEERING DIVISION

TYPE IV HANDHOLE  
DETAIL

STANDARD DETAIL DRAWING 6.25

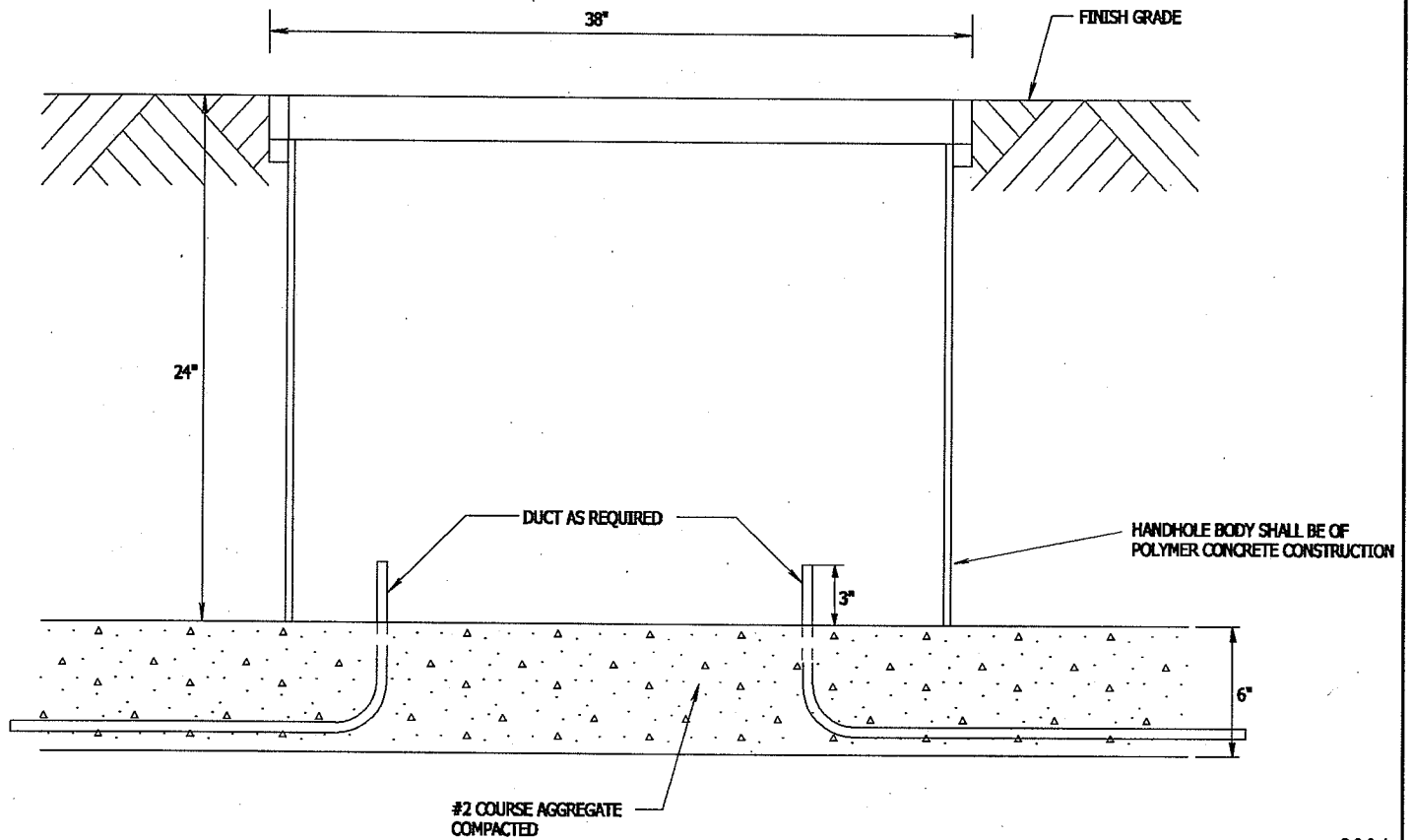
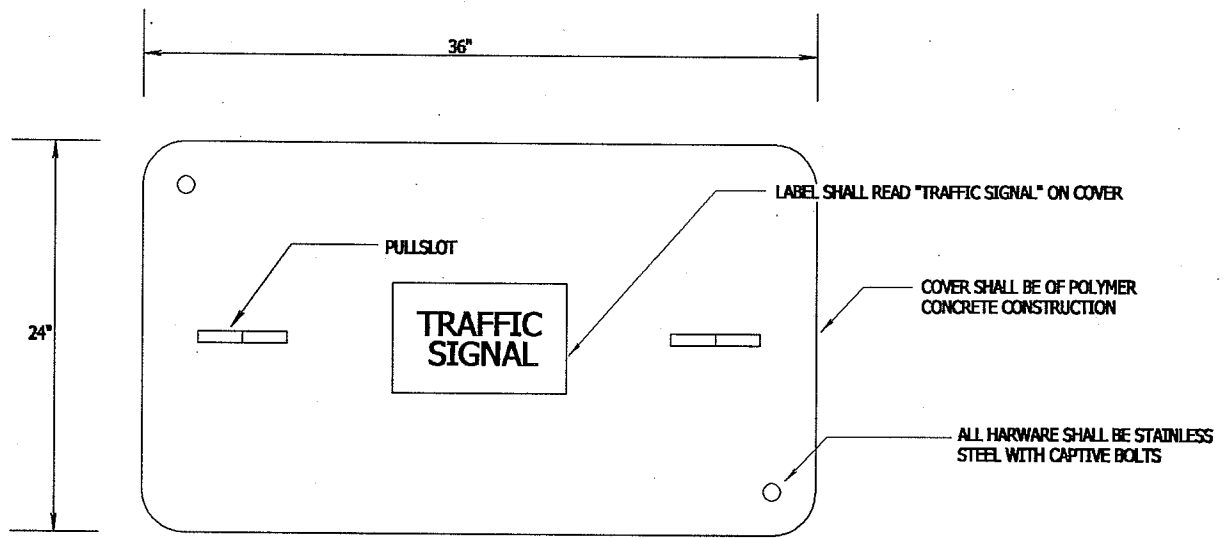

2004

CITY OF MADISON TRAFFIC ENGINEERING DIVISION
<b>TYPE V HANDHOLE DETAIL</b>
STANDARD DETAIL DRAWING 6.26

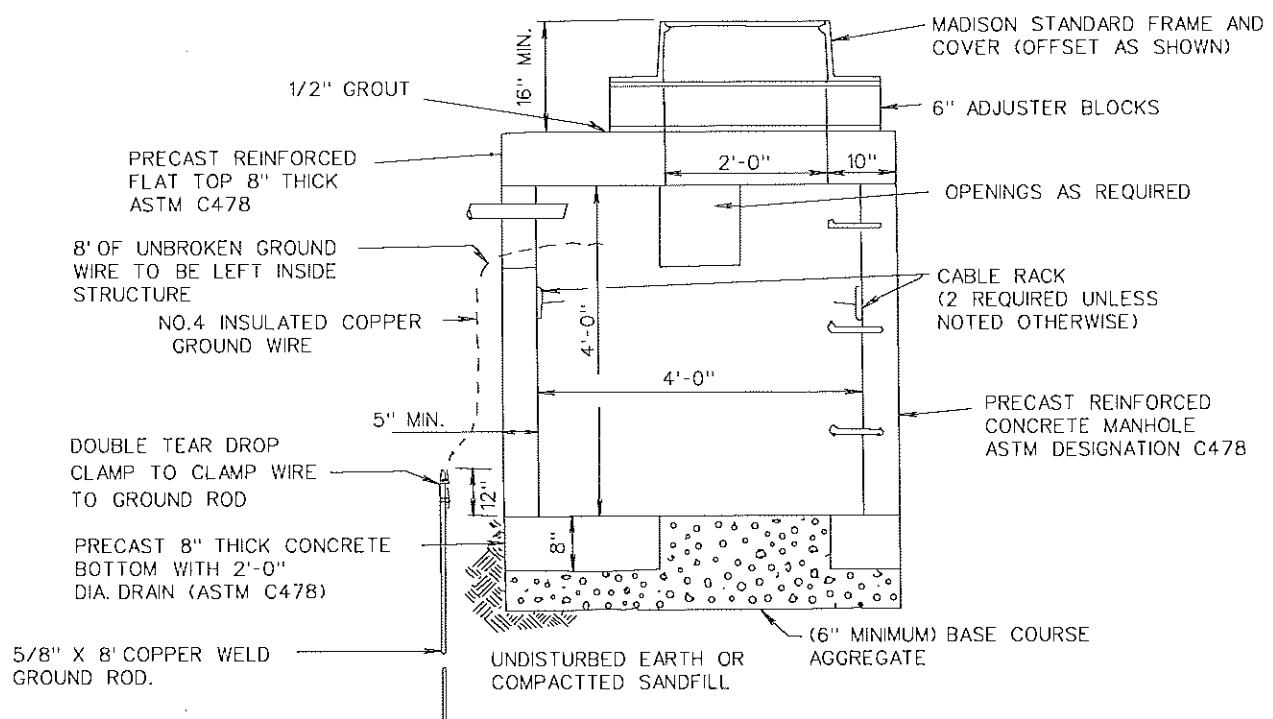
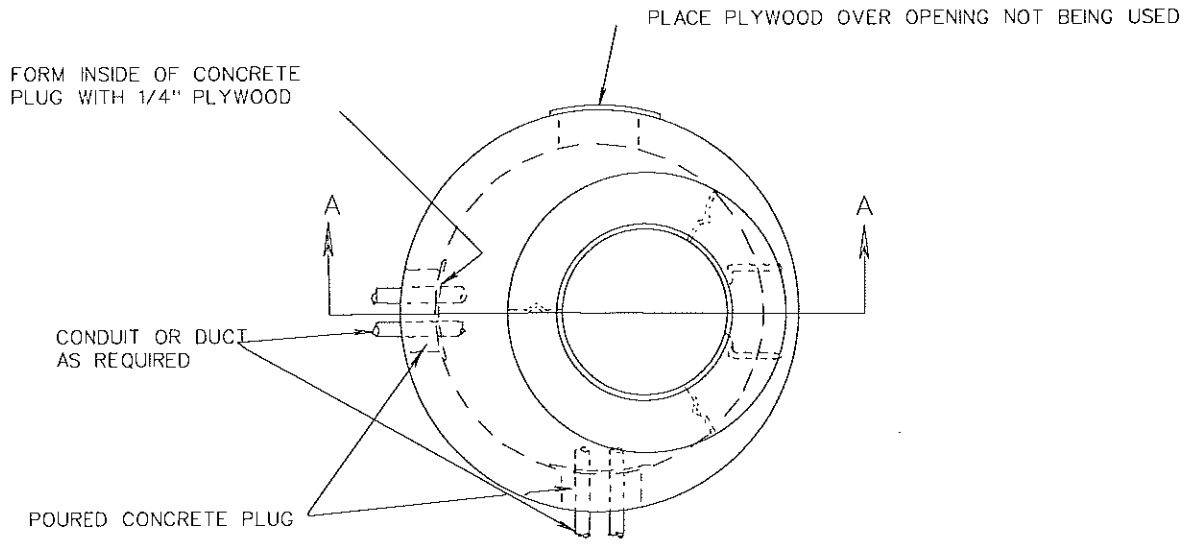

SECTION A-A

2013

CITY OF MADISON TRAFFIC ENGINEERING DIVISION
ELECTRICAL UTILITY ACCESS STRUCTURE DETAIL
STANDARD DETAIL DRAWING 6.27

# SECTION A-A

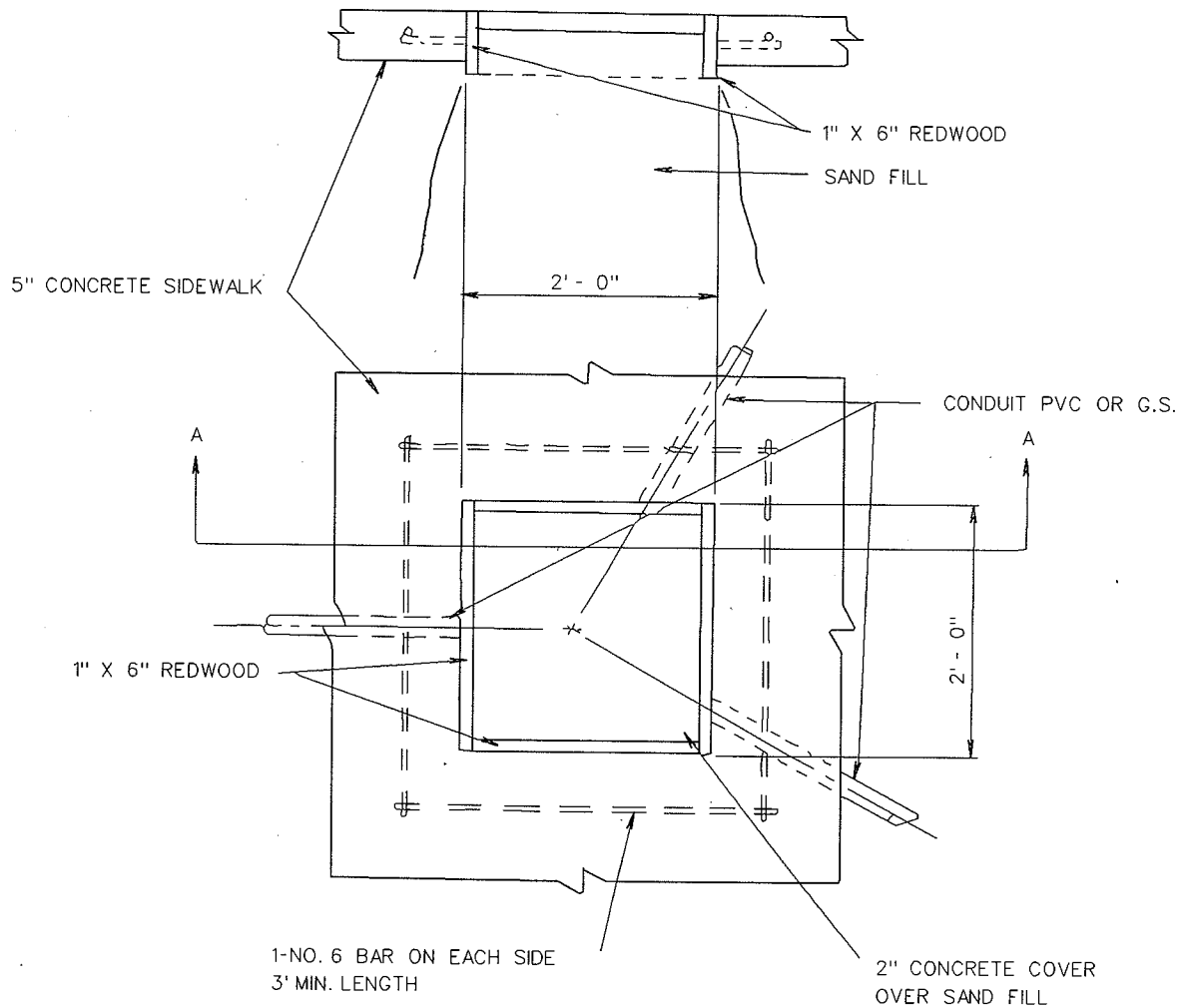

**NOTE:**

CONDUIT OR DUCT SHALL ENTER  
BOX-OUT "ON CENTER" FOR  
MAXIMUM DISTANCE BETWEEN  
CONDUIT OR DUCT ENDS.

2004

CITY OF MADISON  
TRAFFIC ENGINEERING DIVISION

**ELECTRICAL CONDUIT  
BOX-OUT DETAIL**

STANDARD DETAIL DRAWING 6.28

A TYPE III BARRICADE WITH SIGN ATTACHED IS REQUIRED FOR THESE CONDITIONS AND SHALL BE INSTALLED ON STREETS WHERE LARGE TRAFFIC VOLUMES EXIST OR A SAFETY HAZARD IS PRESENT. I.E., DROP IN GRADE IN EXCESS OF 12" FROM THE PAVEMENT SURFACE TO THE GROUND OR A PILE OF DEBRIS AT THE END OF THE STREET.

A TYPE III A BARRICADE WITH SIGN ATTACHED IS REQUIRED TO BE INSTALLED BY THE DEVELOPER RESPONSIBLE ON ALL STREETS WHICH HAVE NOT BEEN ACCEPTED BY THE CITY OF MADISON.

A PORTABLE BARRICADE OF THE REQUIRED TYPE MAY BE USED ON STREETS THAT WILL BE OPENED WITHIN 30 DAYS. A PERMANENT BARRICADE WILL BE USED ON ALL OTHER PROPOSED STREETS.

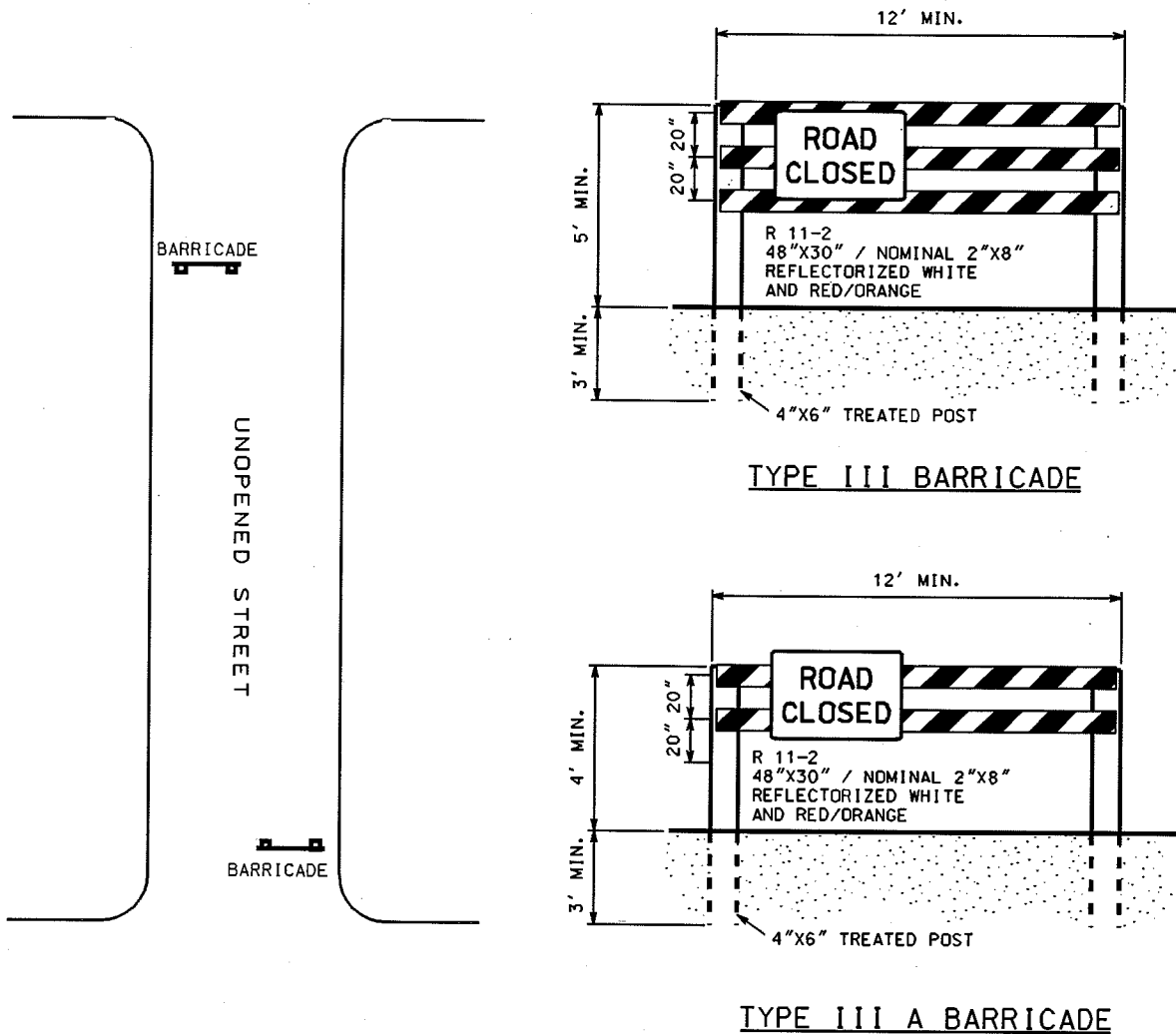

**NOTE:**  
 EACH BARRICADE SHALL HAVE ALTERNATE REFLECTORIZED WHITE AND RED/ORANGE STRIPES 4" TO 6" WIDE AND PLACED AT A 45 DEGREE ANGLE. THE ENTIRE AREA OF WHITE AND RED/ORANGE SHALL BE REFLECTORIZED WITH A SMOOTH, SEALED OUTER SURFACE (3M "SCOTCHLITE" OR BETTER) THAT WILL DISPLAY THE SAME APPROXIMATE SIZE, SHAPE AND COLOR DAY AND NIGHT. FOR FURTHER INFORMATION CALL CITY TRAFFIC ENGINEERING AT 266-4961.

2004

CITY OF MADISON TRAFFIC ENGINEERING DIVISION
<b>STREET BARRICADE DETAILS</b>
STANDARD DETAIL DRAWING 6.29

# SUPPLEMENTAL TRAFFIC CONTROLS FOR BIKEWAY CLOSURES

## ON-ROAD BIKE LANE CLOSURE



W20-B  
30"X30"  
(BLACK ON ORANGE)



R4-11  
30"X30"  
(BLACK ON ORANGE)



(PREFERRED)  
M4-9C  
30"X24"  
(BLACK ON ORANGE)



M4-9C  
30"X24"  
(BLACK ON ORANGE)

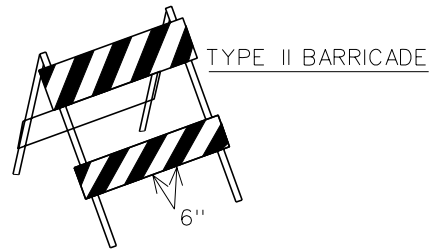

PLACEMENT - ADJACENT TO ON-ROAD BIKE LANE IN ADVANCE OF CLOSURE.

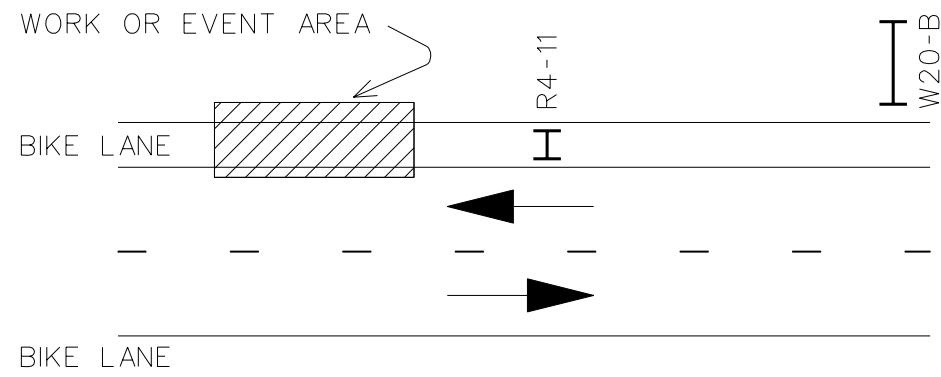

## OFF-ROAD BIKE PATH TYPICAL CLOSURE DETAIL



W20-3B  
18"X18"  
(BLACK ON ORANGE)



R11-2B  
36"X24"  
(BLACK ON WHITE)

PLACEMENT - ADJACENT TO OFF-ROAD BIKE PATH IN ADVANCE OF CLOSURE.

PLACEMENT - IN OFF-ROAD BIKE PATH AT POINT OF CLOSURE.

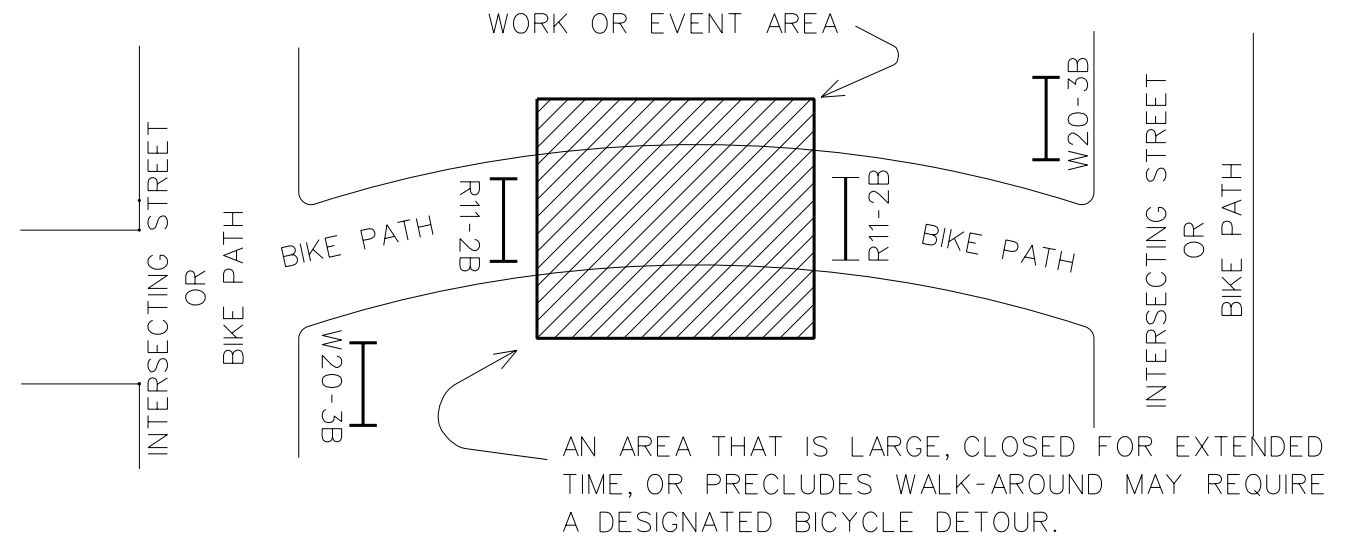

**NOTES:**

- 1) ALL SIGNS MAY BE MOUNTED ON TYPE II BARRICADES, WITH FLASHERS FOR NIGHT TIME USE, UNLESS NOTED OTHERWISE.
- 2) BRIDGING OF TRENCHES - STEEL PLATES USED FOR BRIDGING MAY BE LAID ON THE STREET OR SIDEWALK SURFACE AND PREMIXED ASPHALTIC CONCRETE PLACED AT BOTH ENDS FOR RAMPING. STEEL PLATES USED FOR PEDESTRIAN WALKWAYS OR BIKEWAYS SHALL BE SKID-RESISTANT.

REF: CITY OF MADISON TRAFFIC CONTROLS FOR STREET CONSTRUCTION AND MAINTENANCE OPERATIONS ADDENDUM NO. 1. APPROVED BY THE BOARD OF PUBLIC WORKS, FEB. 4, 1982.

DEC 2010

CITY OF MADISON ENGINEERING DIVISION
<b>SUPPLEMENTAL TRAFFIC CONTROLS FOR BIKEWAY CLOSURES</b>
STANDARD DETAIL DRAWING # 6.30

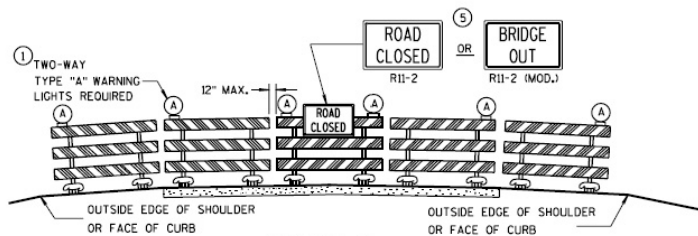

**DETAIL D**  
**ROAD CLOSURE BARRICADE DETAIL**  
APPROACH VIEW

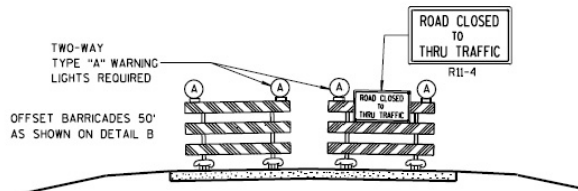

**DETAIL E**  
**LANE CLOSURE BARRICADE DETAIL**  
APPROACH VIEW

## GENERAL NOTES

THE EXACT NUMBER, LOCATION, AND SPACING OF ALL SIGNS AND BARRICADES SHALL BE ADJUSTED TO FIT FIELD CONDITIONS AS APPROVED BY THE ENGINEER.

ANY SIGNS TEMPORARY OR EXISTING, WHICH CONFLICT WITH TRAFFIC CONTROL "IN USE" SHALL BE REMOVED OR COVERED AS NEEDED AND AS APPROVED BY THE ENGINEER.

THE SPACING BETWEEN TRAFFIC CONTROL SIGNS SHOULD BE ADJUSTED TO NOT CONFLICT WITH AND SHOULD PROVIDE A DESIRABLE MINIMUM OF 200 FEET CLEARANCE TO EXISTING SIGNS THAT WILL REMAIN IN PLACE.

BARRICADES THAT MUST BE MOVED FOR A WORK OPERATION SHALL BE IMMEDIATELY RE-ESTABLISHED UPON COMPLETION OF THE OPERATION OR, FOR CONTINUING OPERATIONS, AT THE END OF EACH WORKING DAY.

SIGNS THAT WILL BE IN PLACE LESS THAN 7 CONTINUOUS DAYS AND NIGHTS MAY BE MOUNTED ON PORTABLE SUPPORTS.

ALL TYPE III BARRICADES SHALL HAVE RAILS REFLECTORIZED ON BOTH FACES. STRIPES SHALL BE PROPERLY SLOPED DOWN TOWARD THE TRAFFIC SIDE OR AS SHOWN IN THE ROAD CLOSURE BARRICADE DETAIL D FOR FULL ROAD CLOSURES.

TYPE "A" LOW-INTENSITY FLASHING WARNING LIGHTS SHALL BE VISIBLE ON BOTH SIDES OF THE BARRICADE.

THE R11-2, R11-3, M4-9, R11-4 AND R10-61 SIGNS PLACED ON BARRICADES SHALL COVER NO MORE THAN THE TOP RAIL. THE SIGNS SHALL NOT COVER ANY PORTION OF THE MIDDLE OR BOTTOM RAILS.

THE REFLECTIVE SHEETING USED ON R11-2, R11-3, R11-4, R10-61 AND R1-1 SIGNS SHALL COMPLY WITH SUBSECTION 637.2.2.2 OF THE STANDARD SPECIFICATIONS.

"WO AND "MO" SIGNS ARE THE SAME AS "W" AND "M" SIGNS EXCEPT THE BACKGROUND IS ORANGE.

ALL SIGNS SHALL BE 48" X 48" UNLESS OTHERWISE NOTED BELOW:

R11-2 SHALL BE 48" X 30".

R11-3, R11-4 AND R10-61 SHALL BE 60" X 30".

M4-9 SHALL BE 30" X 24".

M3-X AND M4-8 SHALL BE 24" X 12". (30" X 15" IF NEEDED TO MATCH EXISTING SIGNS.)

M1-4, M1-5A, AND M1-6 SHALL BE 24" X 24". (36" X 36" IF NEEDED TO MATCH EXISTING SIGNS.)

M05-1 AND M06-1 SHALL BE 21" X 21". (30" X 30" IF NEEDED TO MATCH EXISTING SIGNS.)

D1-X SHALL BE AS SHOWN ON SPECIFIC PROJECT SIGNING DETAIL SHEETS.

R1-1 SHALL BE 36" X 36".

- ① TWO WARNING LIGHTS SHALL BE PROVIDED ON THE CENTER BARRICADE AND A MINIMUM OF ONE WARNING LIGHT SHALL BE PROVIDED ON EACH OF THE OTHER BARRICADES WITHIN THE ROADWAY LIMITS. SPACING OF THE WARNING LIGHTS SHALL BE UNIFORM TO THE EDGE OF ROADWAY AS SHOWN (APPROX. 8-FOOT LIGHT SPACING).
- ② THESE SIGNS AND BARRICADES ARE NOT REQUIRED IF ROAD CLOSURE BEGINS AT INTERSECTION.
- ③ FOR ROAD CLOSURE WITHOUT LOCAL ACCESS TO PROJECT, SEE ROAD CLOSURE BARRICADE DETAIL D.
- ④ FOR ROAD CLOSURE WITH LOCAL ACCESS TO PROJECT, SEE LANE CLOSURE BARRICADE DETAIL E.
- ⑤ FOR BRIDGE OR CULVERT REPLACEMENTS, SUBSTITUTE "BRIDGE OUT" INSTEAD OF "ROAD CLOSED" ON R11-2 AND R11-3 SIGNS.
- ⑥ INSTALL DETOUR AND COMMUNITY GUIDE SIGNS AND ARROWS ONLY IF SPECIFIED IN THE CONTRACT. IF THERE ARE EXISTING ROUTE MARKER ASSEMBLIES THAT WILL REMAIN IN PLACE, ADJUST THE LOCATION OF THE DETOUR ROUTE SIGNS TO CORRESPOND WITH THE EXISTING ASSEMBLIES. MODIFY EXISTING SIGNS WHERE POSSIBLE. SEE SPECIFIC PROJECT DETOUR SIGNING DETAIL SHEETS. IF DETOUR SIGNS ARE BEING INSTALLED BY OTHERS, PLACE THE CONTRACTED TRAFFIC CONTROL SIGNS TO ALLOW FOR PLACEMENT OF ALL WARNING, DETOUR AND GUIDE SIGNS AS SHOWN.
- ⑦ "EAST" CARDINAL DIRECTION MARKERS AND RIGHT TURN ARROWS ARE SHOWN. USE OTHER CARDINAL DIRECTIONS AND ARROWS AS APPROPRIATE.

FEB 2005

CITY OF MADISON  
ENGINEERING DIVISION

**BARRICADE AND SIGNS  
FOR MAINLINE CLOSURES**

REFERENCED FROM:  
STATE OF WISCONSIN  
SDD 15 C 2-4B

STANDARD DETAIL DRAWING # 6.31

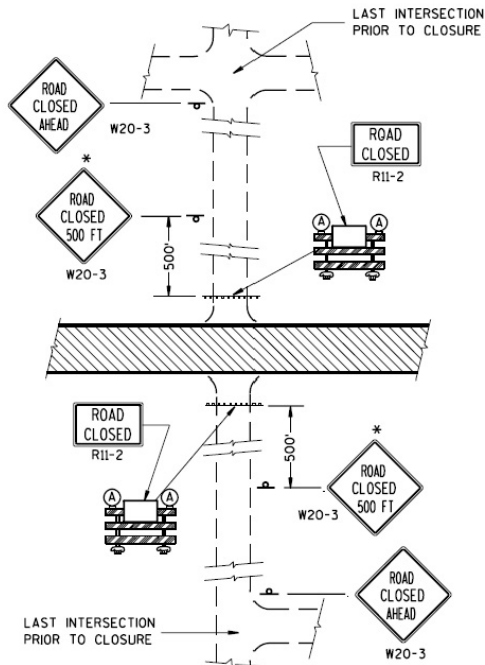

**DETAIL 1**  
(NO ACCESS TO PROJECT)

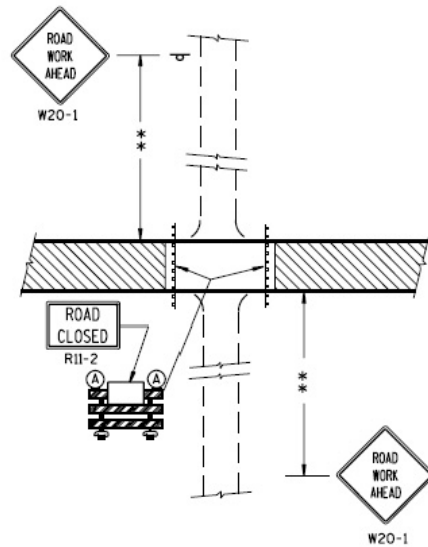

**DETAIL 2**  
(PUBLIC CROSS-TRAFFIC MAINTAINED.  
NO ACCESS TO PROJECT).

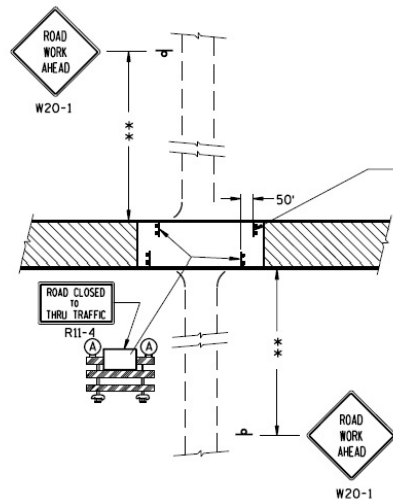

**DETAIL 3**  
(PUBLIC CROSS-TRAFFIC MAINTAINED. CONTRACTOR,  
LOCAL BUSINESS AND RESIDENT ACCESS).

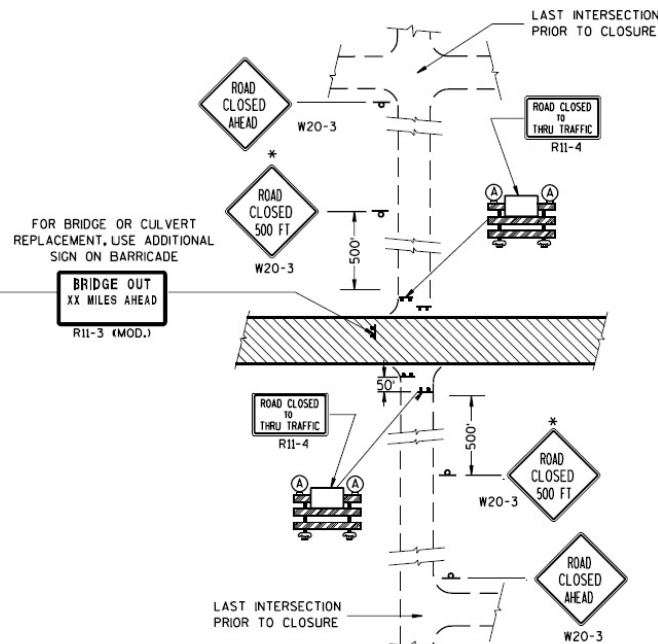

**DETAIL 4**  
(CONTRACTOR, LOCAL BUSINESS AND  
RESIDENT ACCESS TO PROJECT)

**GENERAL NOTES**

THE EXACT NUMBER, LOCATION, AND SPACING OF ALL SIGNS AND BARRICADES SHALL BE ADJUSTED TO FIT FIELD CONDITIONS AS APPROVED BY THE ENGINEER.

ANY SIGNS TEMPORARY OR EXISTING, WHICH CONFLICT WITH TRAFFIC CONTROL "IN USE" SHALL BE REMOVED OR COVERED AS NEEDED AND AS APPROVED BY THE ENGINEER.

THE SPACING BETWEEN TRAFFIC CONTROL SIGNS SHOULD BE ADJUSTED TO NOT CONFLICT WITH AND SHOULD PROVIDE A DESIRABLE MINIMUM OF 200 FEET CLEARANCE TO EXISTING SIGNS THAT WILL REMAIN IN PLACE.

IF A "STOP" SIGN MUST BE REMOVED FOR A WORK OPERATION, A TEMPORARY "STOP" SIGN SHALL BE PLACED PRIOR TO THE SIGN REMOVAL, OR A FLAGGER SHALL BE PROVIDED UNTIL THE SIGN IS RE-ESTABLISHED.

BARRICADES THAT MUST BE MOVED FOR A WORK OPERATION SHALL BE IMMEDIATELY RE-ESTABLISHED UPON COMPLETION OF THE OPERATION OR, FOR CONTINUING OPERATIONS, AT THE END OF EACH WORKING DAY.

SIGNS THAT WILL BE IN PLACE LESS THAN 7 CONTINUOUS DAYS AND NIGHTS MAY BE MOUNTED ON PORTABLE SUPPORTS.

ALL TYPE III BARRICADES SHALL HAVE RAILS REFLECTORIZED ON BOTH FACES. STRIPES SHALL BE PROPERLY SLOPED DOWN TOWARD THE TRAFFIC SIDE OR AS SHOWN IN THE ROAD CLOSURE BARRICADE DETAIL D FOR FULL ROAD CLOSURES.

TYPE "A" LOW-INTENSITY FLASHING WARNING LIGHTS SHALL BE VISIBLE ON BOTH SIDES OF THE BARRICADE.

THE R11-2, R11-3 AND R11-4 SIGNS PLACED ON BARRICADES SHALL COVER NO MORE THAN THE TOP RAIL. THE SIGNS SHALL NOT COVER ANY PORTION OF THE MIDDLE OR BOTTOM RAILS.

THE REFLECTIVE SHEETING USED ON R11-2, R11-3 AND R11-4 SIGNS SHALL COMPLY WITH SUBSECTION 637.2.2.2 OF THE STANDARD SPECIFICATIONS.

ALL SIGNS SHALL BE 48" X 48" UNLESS OTHERWISE NOTED BELOW:

R11-2 SHALL BE 48" X 30".

R11-4 AND R11-3 SHALL BE 60" X 30".

\*OMIT THE "ROAD CLOSED 500 FT." SIGN IF THE LAST INTERSECTION IS 500 FT. OR LESS FROM THE WORK ZONE.

\*\*500' MAX. OR AT LAST INTERSECTION WHICHEVER IS CLOSER.

**LEGEND**

- ⊥ POST MOUNTED WARNING SIGN
- ⊥ TYPE III BARRICADES
- Ⓐ TYPE "A" LOW INTENSITY FLASHING WARNING LIGHT (FOR NIGHT USE)
- ▨ WORK AREA

FEB 2005

CITY OF MADISON  
ENGINEERING DIVISION

**BARRICADES AND SIGNS  
FOR SIDEROAD CLOSURES**

REFERENCED FROM:  
STATE OF WISCONSIN  
SDD 15 C 3-1

STANDARD DETAIL DRAWING # 6.32



6.33

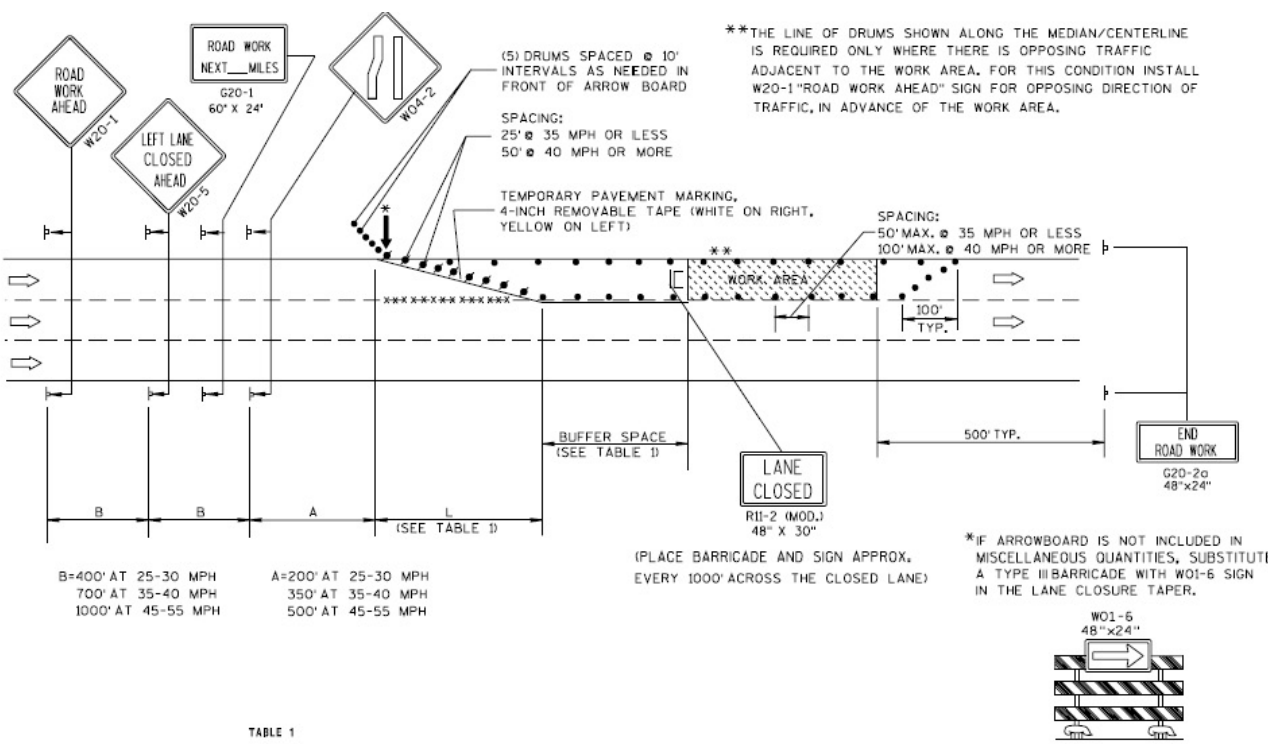

**GENERAL NOTES**

THIS LANE CLOSURE DETAIL IS TYPICAL FOR CLOSING THE LEFT LANE. FOR A RIGHT LANE CLOSURE, REVERSE THE TRAFFIC CONTROL.

THIS DETAIL MAY BE USED FOR ROADWAYS WITH EITHER TWO OR THREE LANES IN EACH DIRECTION.

THE EXACT NUMBER, LOCATION, AND SPACING OF ALL SIGNS AND DEVICES SHALL BE ADJUSTED TO FIT FIELD CONDITIONS AS APPROVED BY THE ENGINEER.

THE SPACING BETWEEN TRAFFIC CONTROL SIGNS SHOULD BE ADJUSTED TO NOT CONFLICT WITH AND SHOULD PROVIDE A DESIRABLE MINIMUM OF 200 FEET CLEARANCE TO EXISTING SIGNS THAT WILL REMAIN IN PLACE.

ALL SIGNS ARE 48"x48" UNLESS OTHERWISE NOTED. IF NECESSARY DUE TO SPACE CONSTRAINTS IN URBAN AREAS, 36" X 36" SIGNS MAY BE USED IF APPROVED BY DISTRICT TRAFFIC UNIT.

"W0" SIGNS ARE THE SAME AS "W" SIGNS EXCEPT THE BACKGROUND IS ORANGE.

SIGNS THAT WILL BE IN PLACE LESS THAN 7 CONTINUOUS DAYS AND NIGHTS, OR THAT WILL BE PLACED IN A CLOSED LANE, MAY BE MOUNTED ON PORTABLE SUPPORTS.

ANY SIGNS TEMPORARY OR EXISTING, WHICH CONFLICT WITH TRAFFIC CONTROL "IN USE" SHALL BE REMOVED OR COVERED AS NEEDED AND AS APPROVED BY THE ENGINEER.

REMOVE PAVEMENT MARKINGS AND PLACE TEMPORARY PAVEMENT MARKING, REMOVABLE TAPE IF LANE CLOSURE IS TO BE IN PLACE FOR 7 OR MORE CONTINUOUS DAYS AND NIGHTS. ON UNDIVIDED ROADWAYS, OMIT THE SIGNS SHOWN ON LEFT SIDE OF ROAD.

W20-1, G20-1 AND G20-2A SIGNS ARE NOT REQUIRED IF THE LANE CLOSURE IS WITHIN A LARGER WORK ZONE WHERE THESE SIGNS ARE ALREADY PRESENT.

OMIT G20-1 SIGNS IF LENGTH OF WORK AREA IS 2 MILES OR LESS.

CONSIDER GEOMETRICS WHEN LOCATING SIGNS AND ARROWBOARDS SO THE APPROACHING DRIVER HAS A CLEAR VIEW OF THE ARROWBOARDS AND LANE CLOSURE DRUMS.

PLACE THE ARROWBOARD AS CLOSE AS POSSIBLE TO THE BEGINNING OF THE LANE CLOSURE TAPER, PREFERABLY ON THE SHOULDER OR TERRACE.

CHANNELIZING DEVICES PLACED ADJACENT TO WORK AREA SHALL BE PULLED BACK FROM THE TRAVEL LANE WHEN WORK IS NOT IN PROGRESS.

BARRICADES IN A CLOSED LANE THAT MUST BE MOVED FOR A WORK OPERATION SHALL BE IMMEDIATELY RE-ESTABLISHED UPON COMPLETION OF THE OPERATION OR, FOR CONTINUING OPERATIONS, AT THE END OF EACH WORKING DAY.

WARNING LIGHTS ARE NOT REQUIRED IF THE LANE CLOSURE IS A DAYTIME ONLY OPERATION.

\*\*THE LINE OF DRUMS SHOWN ALONG THE MEDIAN/CENTERLINE IS REQUIRED ONLY WHERE THERE IS OPPOSING TRAFFIC ADJACENT TO THE WORK AREA. FOR THIS CONDITION INSTALL W20-1 "ROAD WORK AHEAD" SIGN FOR OPPOSING DIRECTION OF TRAFFIC, IN ADVANCE OF THE WORK AREA.

SPACING:  
25' @ 35 MPH OR LESS  
50' @ 40 MPH OR MORE

SPACING:  
50' MAX. @ 35 MPH OR LESS  
100' MAX. @ 40 MPH OR MORE

(PLACE BARRICADE AND SIGN APPROX. EVERY 1000' ACROSS THE CLOSED LANE)

\*IF ARROWBOARD IS NOT INCLUDED IN MISCELLANEOUS QUANTITIES, SUBSTITUTE A TYPE III BARRICADE WITH W01-6 SIGN IN THE LANE CLOSURE TAPER.

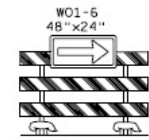

**LEGEND**

- ⊘ DRUM WITH/WITHOUT WARNING LIGHT, TYPE C (STEADY-BURN)
- ⊣ POST MOUNTED SIGN
- ↑ ARROW BOARD
- ⊣/⊣ TYPE III BARRICADE (8' EQUIVALENT) AND WARNING LIGHTS, TYPE A (FLASHING) WITH/WITHOUT SIGN
- DIRECTION OF TRAFFIC FLOW
- xxxx REMOVING PAVEMENT MARKING (SEE GENERAL NOTES)

**TABLE 1  
TAPER AND BUFFER SPACE  
FOR 12' LANE WIDTH**

S	L	BUFFER SPACE
25	125'	55'
30	180'	85'
35	245'	120'
40	320'	170'
45	540'	220'
50	600'	280'
55	660'	335'

FOR LANE WIDTH OTHER THAN 12':  
 L = WS AT 45 MPH OR GREATER  
 L =  $\frac{WS^2}{60}$  AT 40 MPH OR LESS  
 L = TAPER LENGTH IN FEET  
 S = NON-CONSTRUCTION SPEED LIMIT (MPH)  
 W = WIDTH OF LANE CLOSURE

REFERENCED FROM:  
STATE OF WISCONSIN  
SDD 15 D 20-1

FEB 2005

CITY OF MADISON  
ENGINEERING DIVISION

**TRAFFIC CONTROL,  
SINGLE LANE CLOSURE  
NON-FREEWAY/EXPRESSWAY**

STANDARD DETAIL DRAWING # 6.33

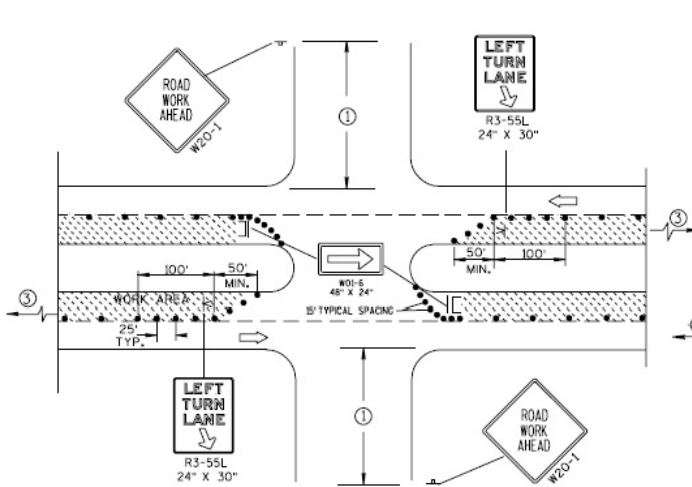

**DETAIL A**  
FOR LEFT LANE CLOSURE AT  
INTERSECTION OR MEDIAN OPENING

PROVIDE TURN LANES AT INTERSECTIONS WHENEVER STAGING OF WORK ALLOWS. TAPER AND TURN LANE LENGTHS BASED ON FIELD CONDITIONS AS APPROVED BY THE ENGINEER.

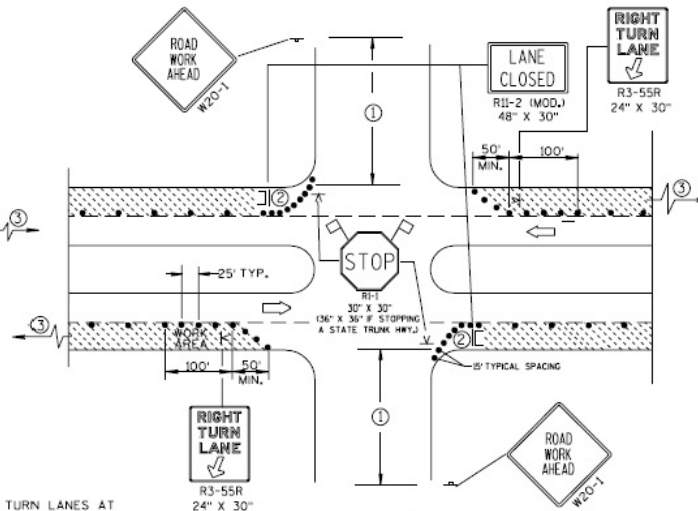

**DETAIL B**  
FOR RIGHT LANE CLOSURE  
AT INTERSECTION

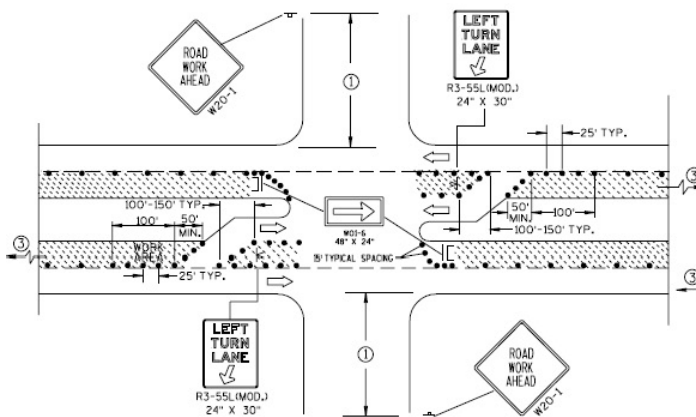

**DETAIL C**  
FOR LEFT LANE CLOSURE AT INTERSECTION OR  
MEDIAN OPENING (WITH LEFT TURN BAY OPEN)

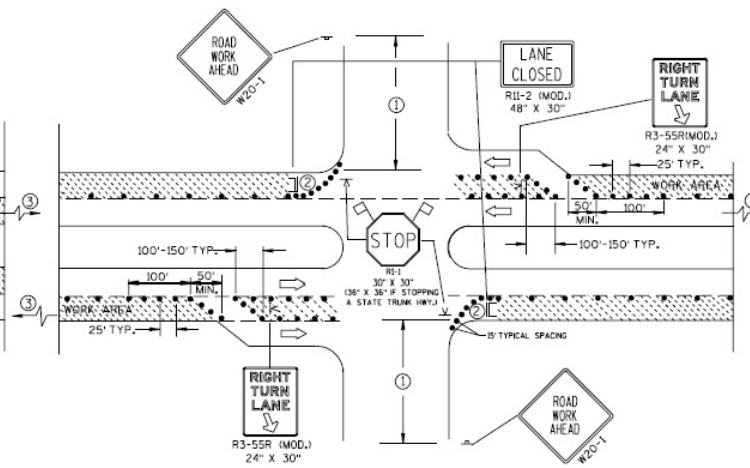

**DETAIL D**  
FOR RIGHT LANE CLOSURE AT INTERSECTION  
(WITH RIGHT TURN BAY OPEN)

**GENERAL NOTES**

THE EXACT NUMBER, LOCATION, AND SPACING OF ALL SIGNS AND DEVICES SHALL BE ADJUSTED TO FIT FIELD CONDITIONS AS APPROVED BY THE ENGINEER.  
THE SPACING BETWEEN SIGNS SHOULD BE ADJUSTED TO NOT CONFLICT WITH AND SHOULD PROVIDE A DESIRABLE MINIMUM OF 200 FEET CLEARANCE TO EXISTING SIGNS THAT WILL REMAIN IN PLACE.

ALL SIGNS ARE 48"x48" UNLESS OTHERWISE NOTED. IF NECESSARY DUE TO SPACE CONSTRAINTS IN URBAN AREAS, 36" X 36" SIGNS MAY BE USED IF APPROVED BY DISTRICT TRAFFIC UNIT.

"W" SIGNS ARE THE SAME AS "R" SIGNS EXCEPT THE BACKGROUND IS ORANGE.  
SIGN LAYOUTS SHALL BE IN ACCORDANCE WITH THE FHWA'S MANUAL OF STANDARD HIGHWAY SIGNS OR THE WISCONSIN STANDARD SIGN PLATES.

SIGNS THAT WILL BE IN PLACE LESS THAN 7 CONTINUOUS DAYS AND NIGHTS, OR THAT WILL BE PLACED IN A CLOSED LANE, MAY BE MOUNTED ON PORTABLE SUPPORTS.

ANY SIGNS TEMPORARY OR EXISTING, WHICH CONFLICT WITH TRAFFIC CONTROL "IN USE" SHALL BE REMOVED OR COVERED AS NEEDED AND AS APPROVED BY THE ENGINEER.

CHANNELIZING DEVICES PLACED ADJACENT TO WORK AREA SHALL BE PULLED BACK FROM THE TRAVEL LANE WHEN WORK IS NOT IN PROGRESS.

BARRICADES IN A CLOSED LANE THAT MUST BE MOVED FOR A WORK OPERATION SHALL BE IMMEDIATELY RE-ESTABLISHED UPON COMPLETION OF THE OPERATION OR, FOR CONTINUING OPERATIONS, AT THE END OF EACH WORKING DAY.

- ① 500' TYPICAL OR AT LAST INTERSECTION, WHICHEVER IS CLOSER.  
350' IF 35-40 MPH,  
200' IF 25-30 MPH.
- ② ALSO USE BARRICADE AND 15' TYPICAL DRUM SPACING AT COMMERCIAL DRIVEWAYS.
- ③ SEE SEPARATE LANE CLOSURE DETAIL FOR ADDITIONAL TRAFFIC CONTROL.

**LEGEND**

- DRUM
- ⊣ POST MOUNTED SIGN
- ⊣ SIGN ON PORTABLE SUPPORT (5' MIN. MOUNTING HEIGHT)
- ⊣ TYPE III BARRICADE (8" EQUIVALENT) AND WARNING LIGHT, TYPE A (FLASHING) WITH SIGN
- ➡ DIRECTION OF TRAFFIC FLOW
- ⚠ FLAGS, 16" X 16" MIN., ORANGE

FEB 2005

CITY OF MADISON  
ENGINEERING DIVISION

**TRAFFIC CONTROL,  
INTERSECTION WITHIN  
SINGLE LANE CLOSURE**

STANDARD DETAIL DRAWING # 6.34

REFERENCED FROM:  
STATE OF WISCONSIN  
SDD 15 D 21-1

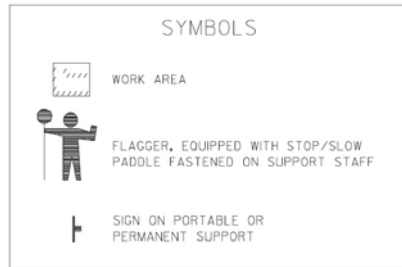

USE OF THE "BE PREPARED TO STOP" SIGN IS OPTIONAL. WHEN USED, THIS SIGN SHALL BE LOCATED BETWEEN THE W20-7a AND W20-4 SIGNS. A 500' TYPICAL SPACING SHALL BE PROVIDED BETWEEN THE SIGNS.

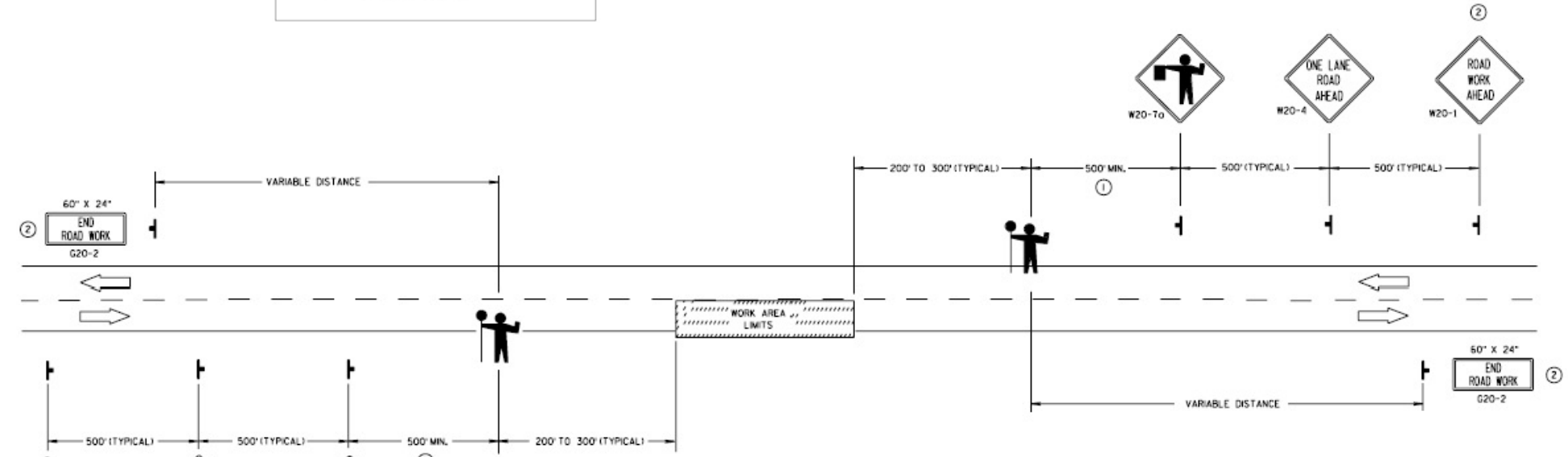

GENERAL NOTES

DETAILS OF TRAFFIC CONTROL DEVICES AND INSTALLATION NOT SHOWN ON THIS DRAWING SHALL CONFORM TO THE PERTINENT REQUIREMENTS OF THE STANDARD SPECIFICATIONS, THE SPECIAL PROVISIONS, AND THE MANUAL ON UNIFORM TRAFFIC CONTROL DEVICES.

THE EXACT NUMBER, LOCATION AND SPACING OF ALL SIGNS AND DEVICES (AND THE LOCATION OF ALL FLAGGERS) SHALL BE ADJUSTED TO FIT FIELD CONDITIONS AS DIRECTED BY THE ENGINEER.

THE FIRST ADVANCE WARNING SIGN SHOULD TYPICALLY BE LOCATED IN ADVANCE OF THE ANTICIPATED TRAFFIC BACKUP OR QUEUE.

WHEN A SIDE ROAD OR RAMP INTERSECTS THE FACILITY ON WHICH THE WORK IS BEING PERFORMED, ADDITIONAL TRAFFIC CONTROLS SHALL BE PROVIDED AS SPECIFIED IN THE PLANS AND/OR THE SPECIAL PROVISIONS OR AS DIRECTED BY THE ENGINEER.

FLAGGERS SHALL BE IN SIGHT OF EACH OTHER OR IN DIRECT COMMUNICATION AT ALL TIMES. THEY SHALL BE EQUIPPED WITH STOP/SLOW PADDLES FASTENED ON SUPPORT STAFFS. WHEN THE FLAGGING OPERATION IS NOT IN EFFECT, THE "FLAGGER AHEAD", THE "ROAD WORK AHEAD" AND THE ONE LANE ROAD AHEAD" SIGNS SHALL BE COVERED OR REMOVED AND THE HIGHWAY RESTORED TO NORMAL OPERATION.

ALL SIGNS ARE 48" X 48" UNLESS OTHERWISE NOTED.

DESIGN NOTE: (WILL NOT APPEAR ON CONTRACT PLANS)

DROP OFFS OR OPEN TRENCHES ADJACENT TO ONE LANE TRAFFIC OPERATIONS SHOULD BE MARKED WITH CONES OR DRUMS. PROVIDE APPROPRIATE DETAILS AND/OR SPECIAL PROVISIONS WHEN THIS CONDITION IS EXPECTED.

THIS DETAIL IS APPROPRIATE FOR RURAL HIGH SPEED CONDITIONS. URBAN LOWER SPEED CONDITIONS REQUIRE A CLOSER SIGN SPACING.

- ① FOR A MOVING WORK OPERATION, SIGNING FOR BOTH DIRECTIONS SHALL BE REESTABLISHED (AS SIMULTANEOUSLY AS PRACTICAL) AT APPROXIMATELY 3500 FOOT INTERVALS IN THE MOVING WORK OPERATION OR AS DIRECTED BY THE ENGINEER.
- ② SIGN NOT REQUIRED IF FLAGGING OPERATION OCCURS WITHIN A SIGNED ROAD WORK ZONE AREA.

FEB 2005

CITY OF MADISON  
ENGINEERING DIVISION



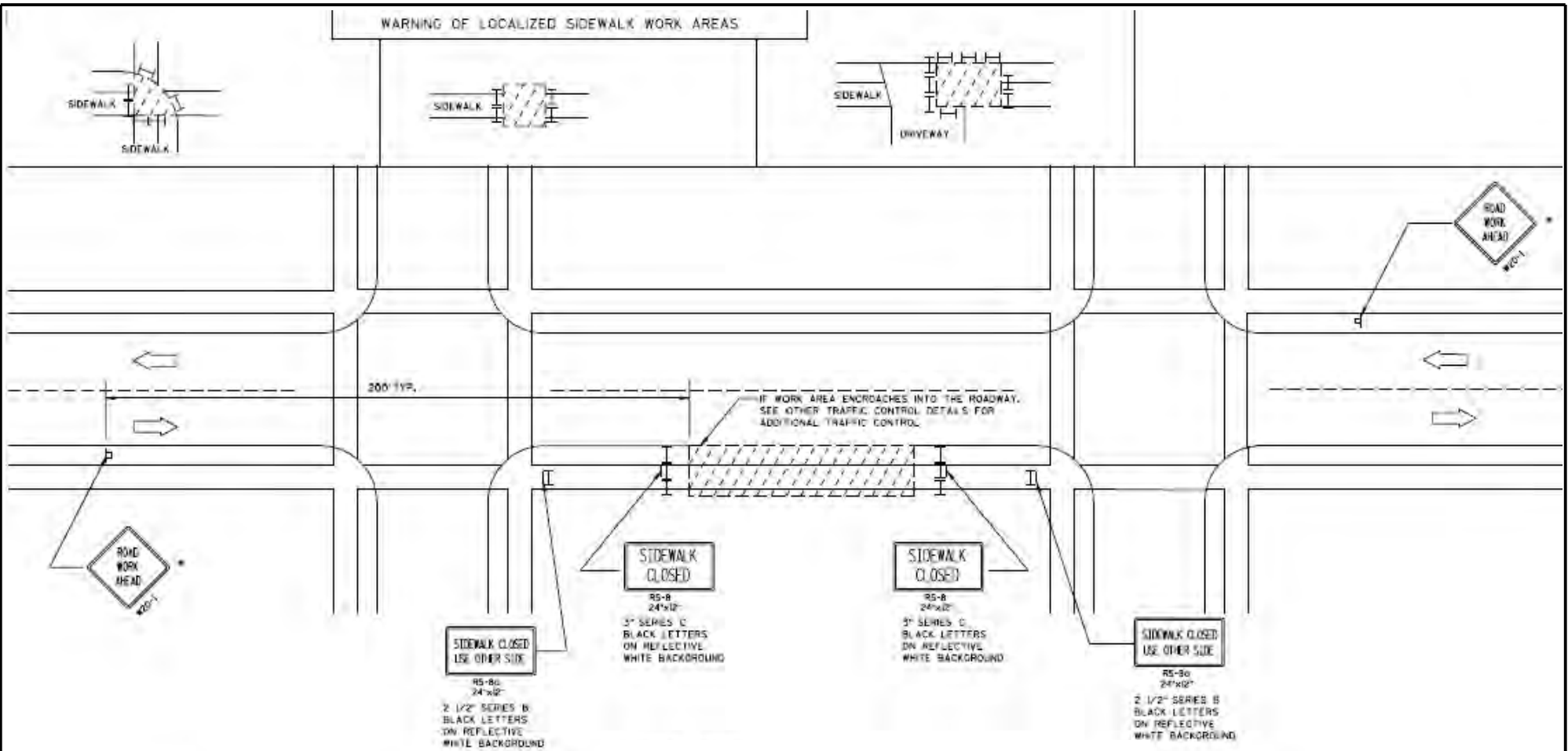

**TRAFFIC CONTROL FOR  
LANE CLOSURE (SUITABLE  
FOR MOVING OPERATIONS)**

STANDARD DETAIL DRAWING # 6.35

REFERENCED FROM:  
STATE OF WISCONSIN  
SDD 15 C 12-2

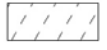

**LEGEND**

-  POST MOUNTED SIGN
-  TYPE II BARRICADE WITH/WITHOUT SIGN (ALL WITH ONE WARNING LIGHT, TYPE A, LOW-INTENSITY FLASHING)
-  WORK AREA
-  DIRECTION OF TRAFFIC FLOW

**GENERAL NOTES :**

ALL SIGNS ARE 48"x48" UNLESS OTHERWISE NOTED, IF NECESSARY DUE TO SPACE CONSTRAINTS, 36"x36" SIGNS MAY BE USED INSTEAD OF 48"x48" SIGNS, IF APPROVED BY DISTRICT TRAFFIC UNIT.

THE EXACT LOCATION AND PLACEMENT OF ALL SIGNS AND DEVICES SHALL BE ADJUSTED TO FIT FIELD CONDITIONS.

"W0" SIGNS ARE THE SAME AS "W" SIGNS EXCEPT THE BACKGROUND IS ORANGE.

\* "ROAD WORK AHEAD" SIGNS ARE NOT REQUIRED IF THE SIDEWALK CLOSURE OCCURS WITHIN A LARGER WORK ZONE WHERE ADVANCE WARNING SIGNS ARE ALREADY PRESENT, OR IF THE WORK AREA AND EQUIPMENT ARE MORE THAN 2 FEET BEHIND THE CURB.

WARNING SIGNS THAT WILL BE IN PLACE LESS THAN 7 CONTINUOUS DAYS AND NIGHTS MAY BE MOUNTED ON PORTABLE SUPPORTS.

FEB 2005

CITY OF MADISON  
ENGINEERING DIVISION

**TRAFFIC CONTROL,  
SIDEWALK CLOSURE**

REFERENCED FROM:  
STATE OF WISCONSIN  
SDD 15 D 30-1

STANDARD DETAIL DRAWING # 6.36

**PERMANENT PAVEMENT MARKINGS**

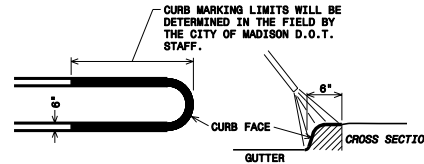
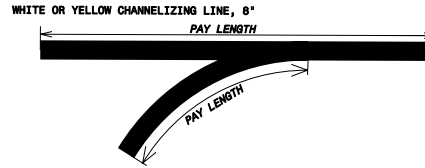
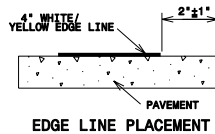
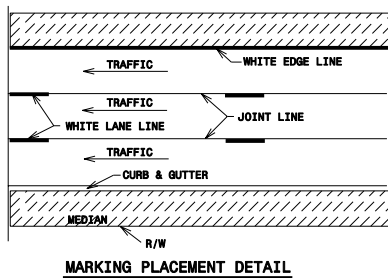
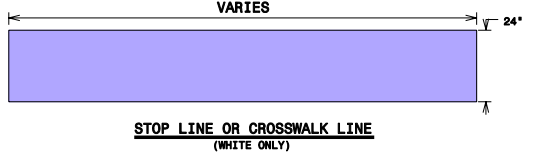
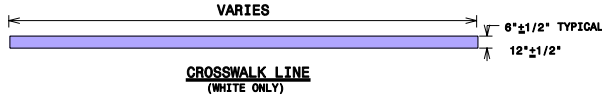
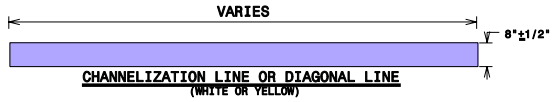
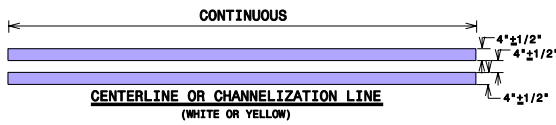
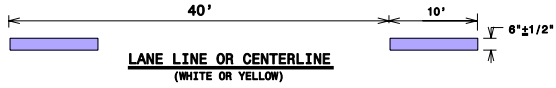
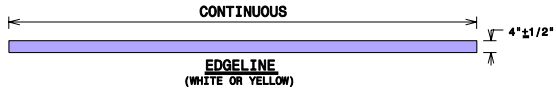
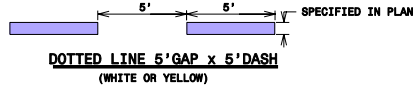
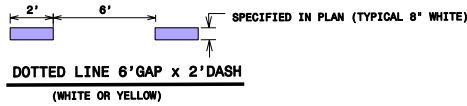

**GENERAL NOTES FOR EPOXY PAVEMENT MARKINGS**

THE CONTRACTOR SHALL APPLY ALL MARKINGS IN ACCORDANCE WITH THE STATE OF WISCONSIN MANUAL ON TRAFFIC CONTROL DEVICES.

AT STREET INTERSECTIONS, MARKINGS START OR END AT THE MARKED CROSSWALK. THE PROPERTY LINE EXTENDED, IF THERE IS NO MARKED CROSSWALK.

CROSSWALKS AND STOP BARS WILL BE PLACED NO CLOSER THAN 2' TO THE FACE OF CURB.

THE CONTRACTOR SHALL ADHERE TO THE TRAFFIC SPECIFICATION IN THE SPECIAL PROVISIONS AT ALL TIMES.

FOR MORE INFORMATION AND FULL SIZE PATTERNS FOR ARROWS & WORD LEGENDS ARE AVAILABLE AT THE CITY OF MADISON TRAFFIC ENGINEERING FIELD OPERATIONS FACILITY 1120 SAYLE ST. (608) 266-4767

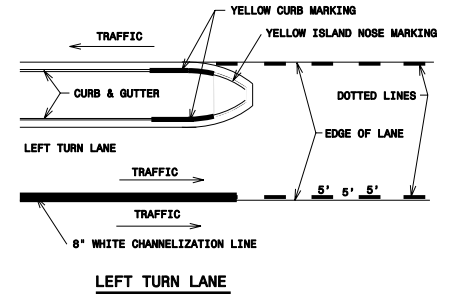
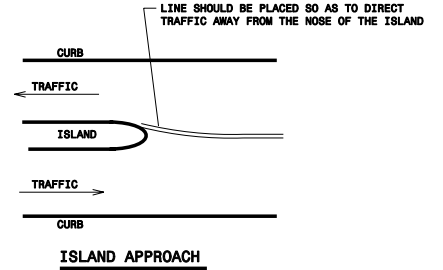

2009

CITY OF MADISON  
ENGINEERING DIVISION

**PAVEMENT MARKING  
DETAILS  
PAGE 1**

STANDARD DETAIL DRAWING # 6.37

6.37

SPECIAL CROSSWALKS

SPECIAL CROSSWALKS HAVE TWO(2) 12-INCH WIDE LINES PLACED ACROSS THE TRAFFIC FLOW AND 24-INCH WIDE CROSSBARS IN LINE WITH THE TRAFFIC FLOW.

THE SPACING OR GAP BETWEEN THE CROSSBARS IS DETERMINED IN THE FIELD AND VARIES BETWEEN 24 TO 48 INCHES SO THAT NO CROSSBAR IS PLACED IN THE MAIN WHEEL TRACK AREA.

TYPICALLY, A CROSSBAR IS CENTERED ON THE CENTERLINE. ANOTHER CROSSBAR IS CENTERED BETWEEN THE WHEEL TRACKS AND ANOTHER CROSSBAR PLACED BETWEEN THE OUTSIDE WHEEL TRACK AND THE EDGE OF GUTTER OR PAVEMENT. IN NO CASE SHALL THE CROSSBAR BE PLACED IN OR NEXT TO THE GUTTER SECTION.

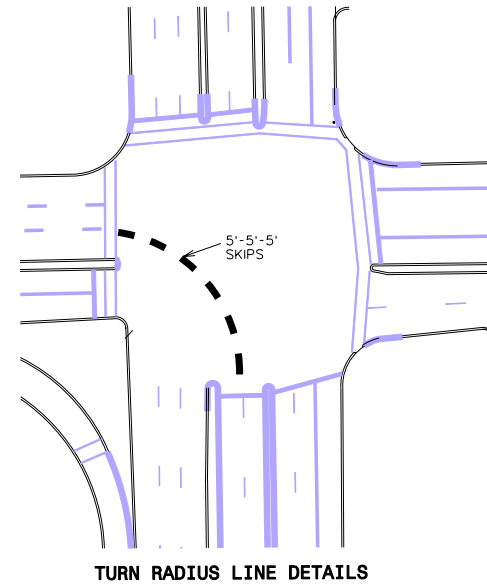
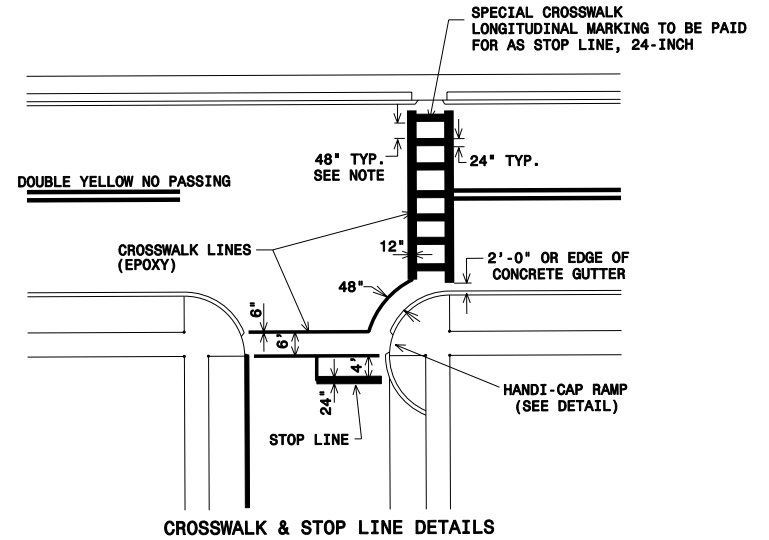

2009

CITY OF MADISON ENGINEERING DIVISION
<b>PAVEMENT MARKING DETAILS PAGE 2</b>
STANDARD DETAIL DRAWING # 6.38

6.38

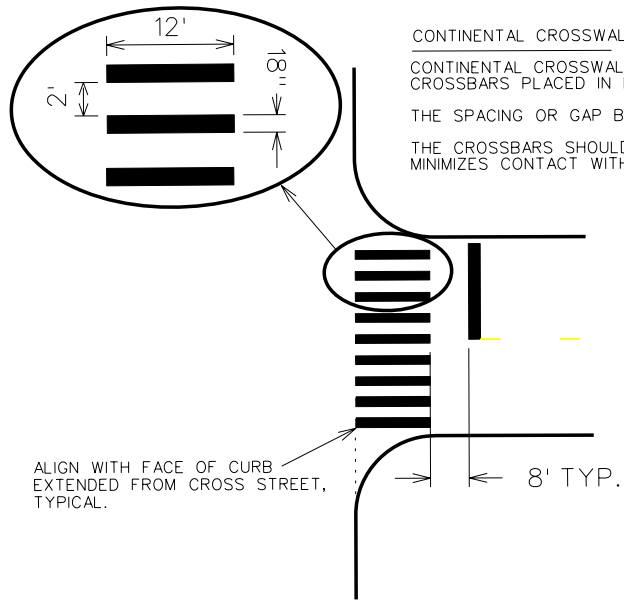

CONTINENTAL CROSSWALKS

CONTINENTAL CROSSWALKS HAVE 18 INCH WIDE 12 FOOT LONG CROSSBARS PLACED IN LINE WITH THE TRAFFIC FLOW.

THE SPACING OR GAP BETWEEN THE CROSSBARS IS 24 INCHES

THE CROSSBARS SHOULD BE PLACED IN A MANNER THAT MINIMIZES CONTACT WITH VEHICLES TIRES.

# RESTRICTED TRAFFIC LANE MARKING DETAILS

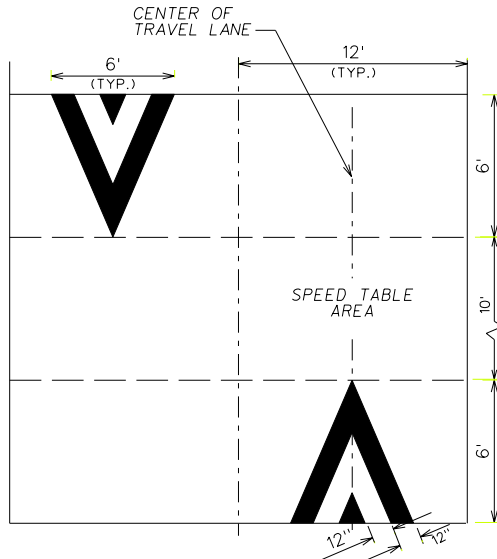

↓ DIRECTION OF TRAVEL ↑  
**MARKINGS FOR SPEED HUMPS**

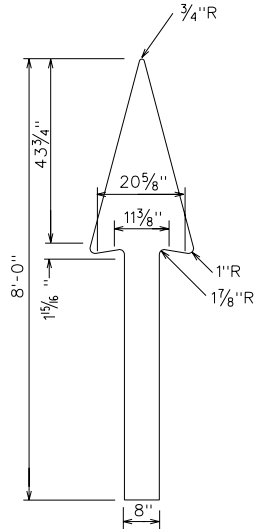

**STRAIGHT ARROW**

LEFT ARROW'S DIMENSIONS SAME AS SHOWN ON RIGHT ARROW

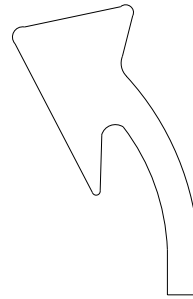

**LEFT ARROW**

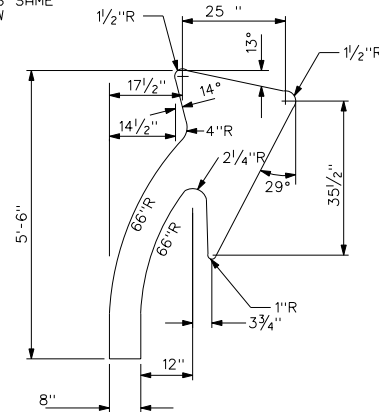

**RIGHT ARROW**

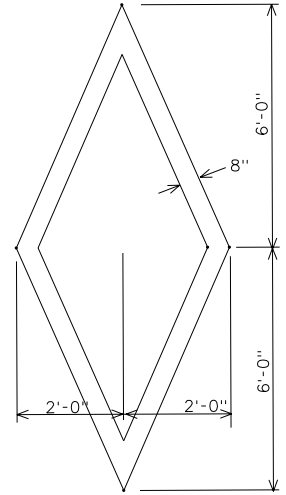

**RESTRICTED LANE SYMBOL**

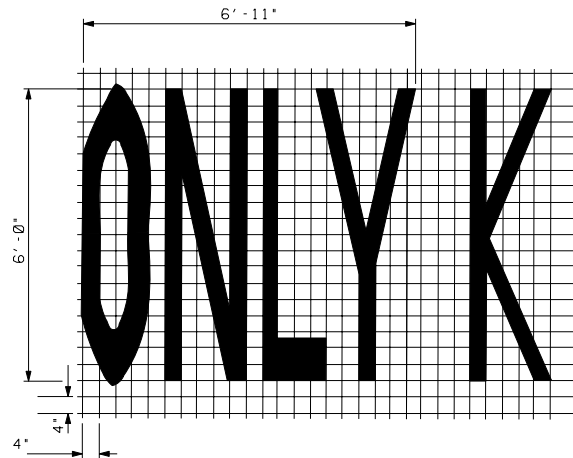

**WORD LEGEND**

FULL SIZE PATTERNS FOR ARROWS & WORD LEGENDS ARE AVAILABLE AT:  
CITY OF MADISON TRAFFIC ENGINEERING  
FIELD OPERATIONS FACILITY  
1120 SAYLE ST. (608)266-4767

FEB 2005

CITY OF MADISON  
ENGINEERING DIVISION

**PAVEMENT MARKING  
DETAILS  
PAGE 3**

STANDARD DETAIL DRAWING # 6.39

# BIKE LANE MARKING DETAILS

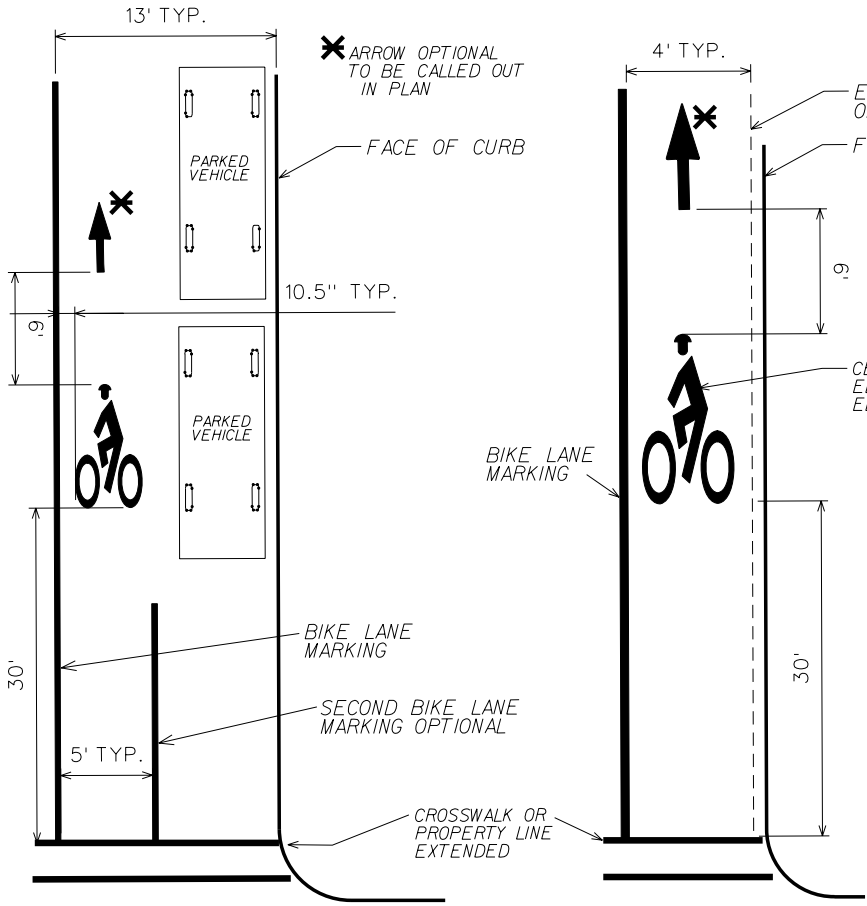

LEFT ARROW'S DIMENSIONS SAME AS SHOWN ON RIGHT ARROW

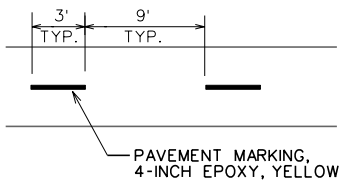
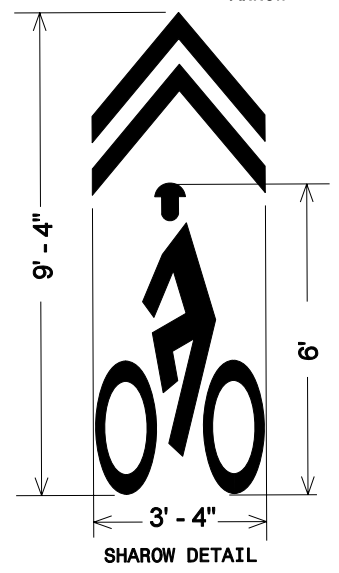
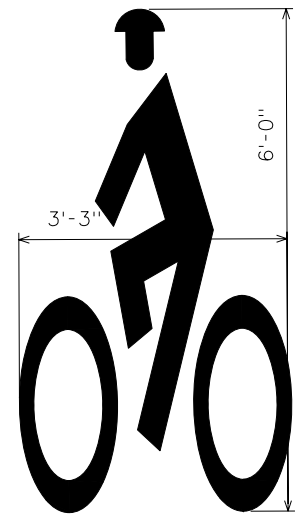
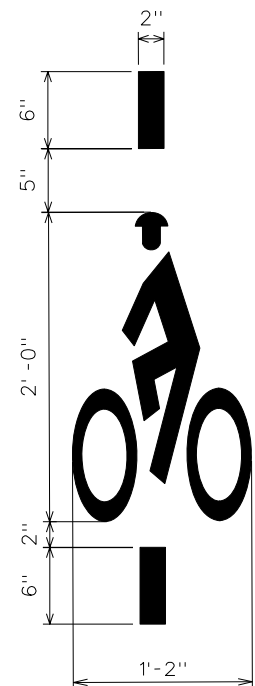
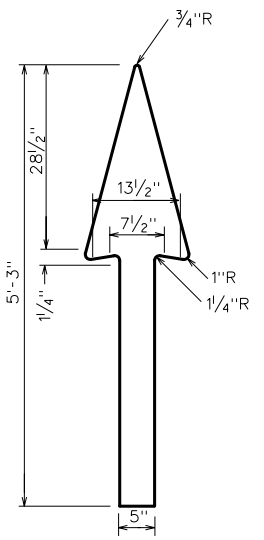
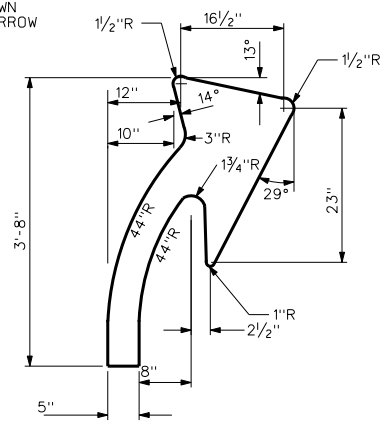

FULL SIZE PATTERNS FOR ARROWS & WORD LEGENDS ARE AVAILABLE AT: CITY OF MADISON TRAFFIC ENGINEERING FIELD OPERATIONS FACILITY 1120 SAYLE ST. (608)266-4767

2009

CITY OF MADISON ENGINEERING DIVISION
<b>PAVEMENT MARKING DETAILS PAGE 4</b>
STANDARD DETAIL DRAWING # 6.40

6.40



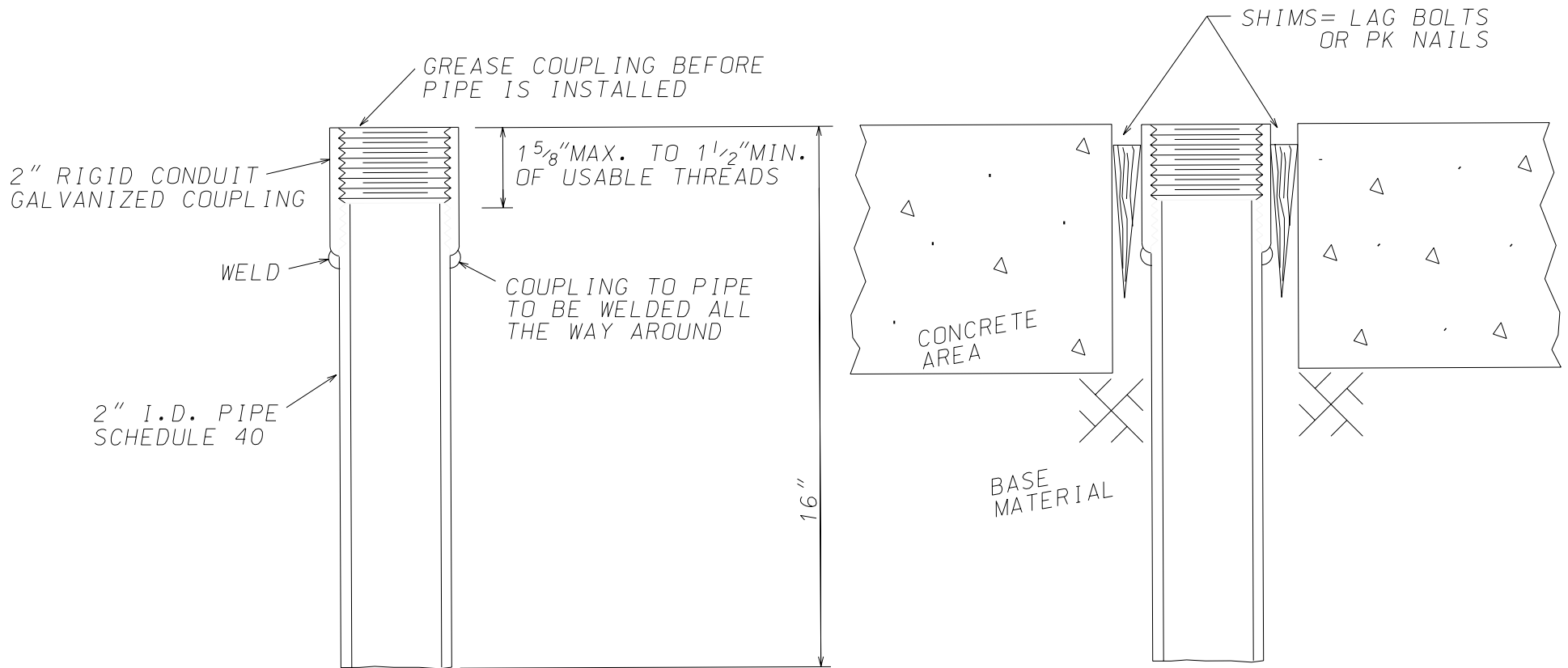

**SIGN POST FOR CONCRETE INSTALLATION:**

Drill or Coredrill 3" hole all the way through the concrete to the base material. With a temporary pipe 4 feet to 5 feet long, hand-tighten it into the insert (see Insert detail). Drive the insert into the base material at a level/plumb position, until the insert is flush with the top of the concrete. Now shim insert to a level/plumb position. Shims = different sizes of lag bolts or P.K. nails depend on level/plumb position of pipe. Also all shims must be set below the concrete/insert. Remove temporary pipe, replace with permanent pipe, tighten into insert with large pipe wrench until insert turns, then reset shims/or add shims until pipe no longer turns. Retighten pipe, recheck level/plumb/top of concrete with insert. Mix up a patch of Thorogrip® which is a waterproof anchoring cement for concrete. For the installation, Thorogrip should be mixed up in a liquid consistency, not a paste. Around the outside of the concrete hole, pour the Thorogrip until it is flush with the top of the insert. Recheck level/plumb/top of concrete with insert right away since Thorogrip is a fast-setting anchoring cement. May need to add more Thorogrip as it settles and no shims are showing when installation is complete. Installation needs to be level/plumb, solid and strong when completed.

FEB 2005

CITY OF MADISON  
ENGINEERING DIVISION

**PIPE INSERT IN  
CONCRETE FOR  
SIGNING**

STANDARD DETAIL DRAWING # 6.41

6.42

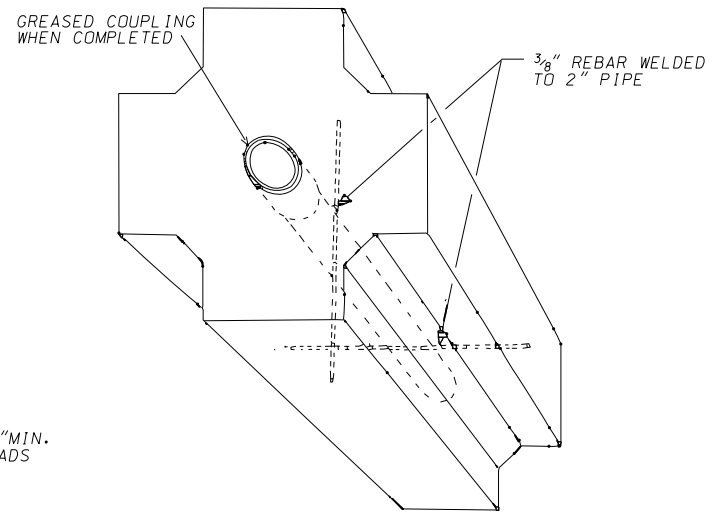
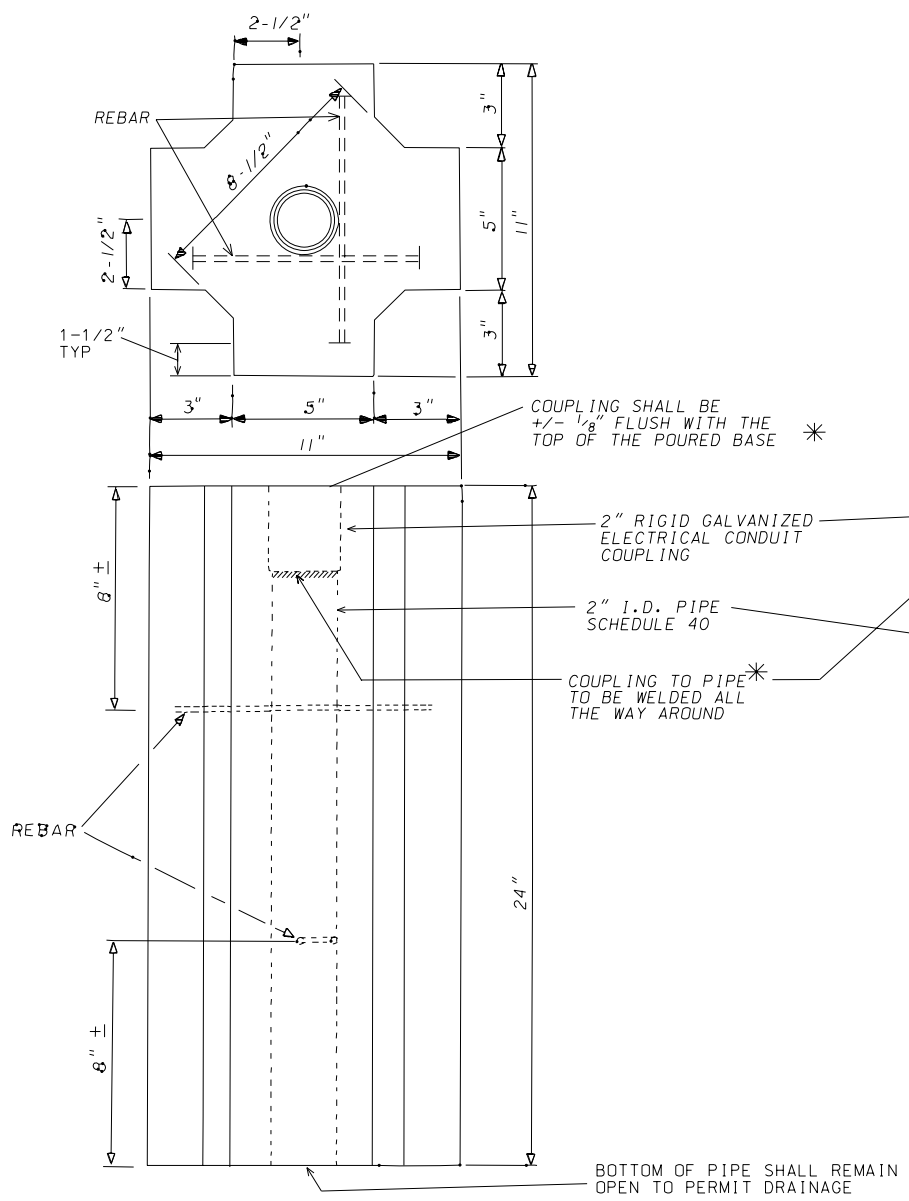

- \*NOTES:
1. CONCRETE 3200 PSI MINIMUM STRENGTH IN 28 DAYS
  2. BASE SHALL BE INSTALLED PLUMB, WITH TOP OF BASE FLUSH WITH FINISHED GRADE.

FEB 2005

CITY OF MADISON ENGINEERING DIVISION
<b>PRECAST SIGN POST BASE DETAILS</b>
STANDARD DETAIL DRAWING # 6.42

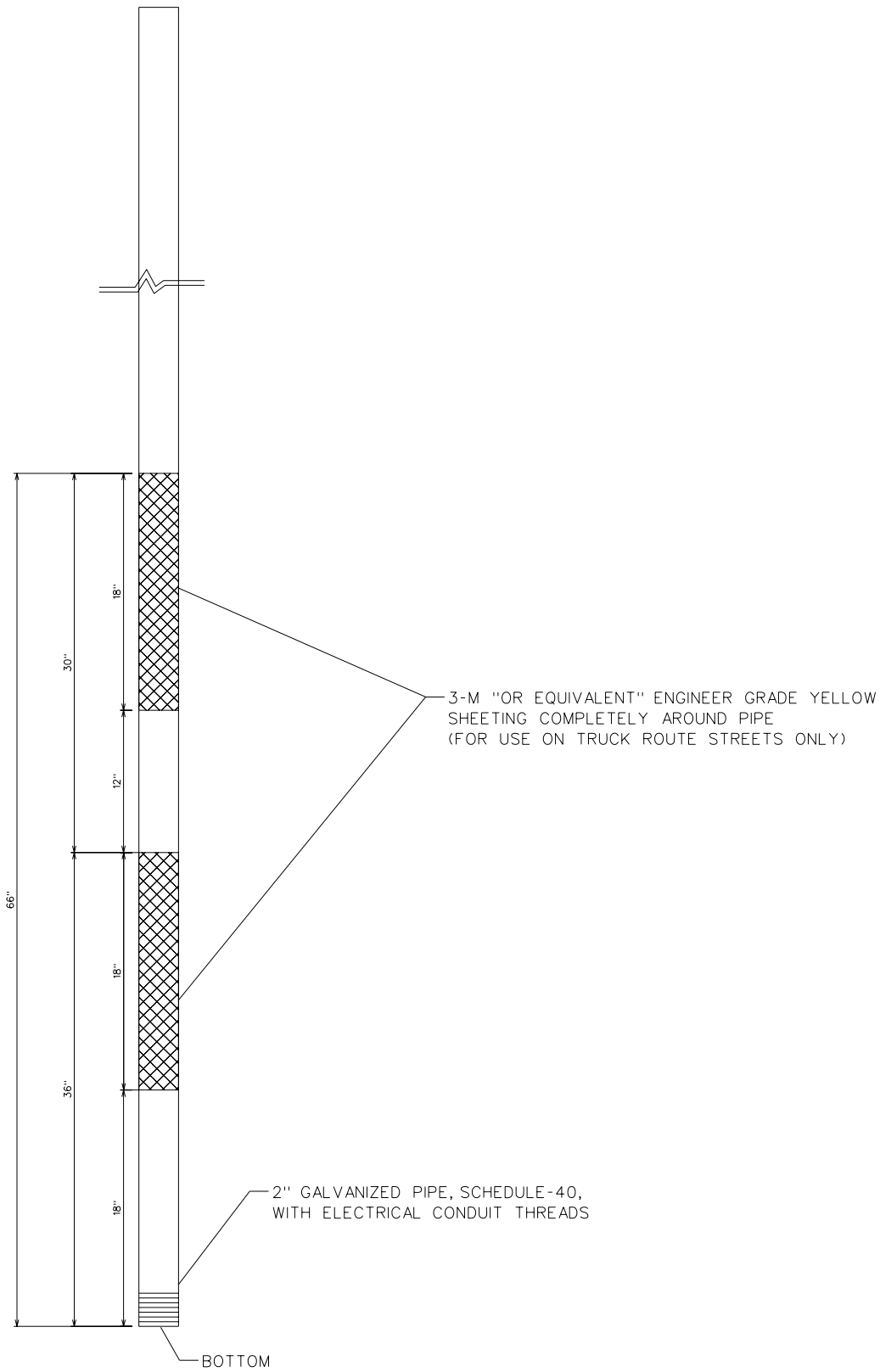

SIGN POST

FEB 2005

CITY OF MADISON  
ENGINEERING DIVISION

SIGN POST DETAIL

STANDARD DETAIL DRAWING # 6.43

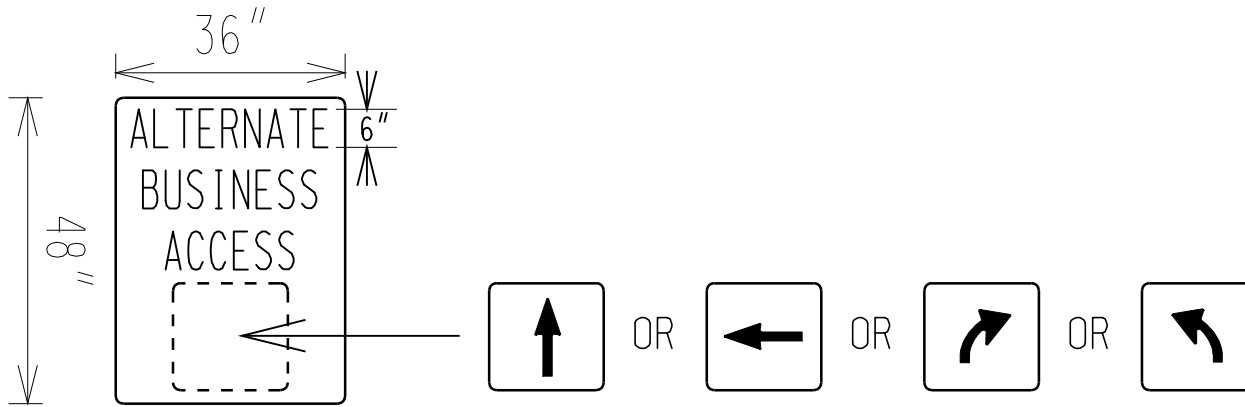

- NOTES:
1. BUSINESS ACCESS SIGNS SHALL BE PAYED BY BID ITEM 10725
  2. LEAVE SPACE BELOW SIGN ON POST FOR ATTACHMENT OF BUSINESS NAME SIGNS (PROVIDED BY OTHERS)
  3. DO NOT MOUNT ON TO ANY EXISTING SIGN POST OR WITH ANY OTHER SIGN
  4. SIGN SHALL BE BLACK LETTERS AND ARROWS ON WHITE BACKGROUND

CITY OF MADISON ENGINEERING DIVISION
ALTERNATE BUSINESS ACCESS SIGN
STANDARD DETAIL DRAWING #6.44

10" DIAMETER  
BOLT CIRCLE

3-7/8"

4-NO 6 REBARS  
2" MIN COVER

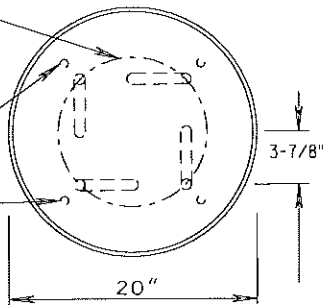

3' OF UNBROKEN GROUND  
WIRE TO BE LEFT ABOVE  
CONCRETE BASE FOR USE  
BY OTHERS

EXISTING TERRACE

CONDUIT MUST BE  
30" BELOW TOP OF  
BASE

CLAMP GROUND WIRE TO  
ANCHOR BOLT W/WATER  
PIPE TYPE GROUND CLAMP

1-NO 4 STRANDED  
INSULATED COPPER WIRE

CLAMP GROUND WIRE TO  
GROUND ROD W/TEAR  
DROP TYPE CLAMP

5/8" X 8' COPPER WELD  
GROUND ROD

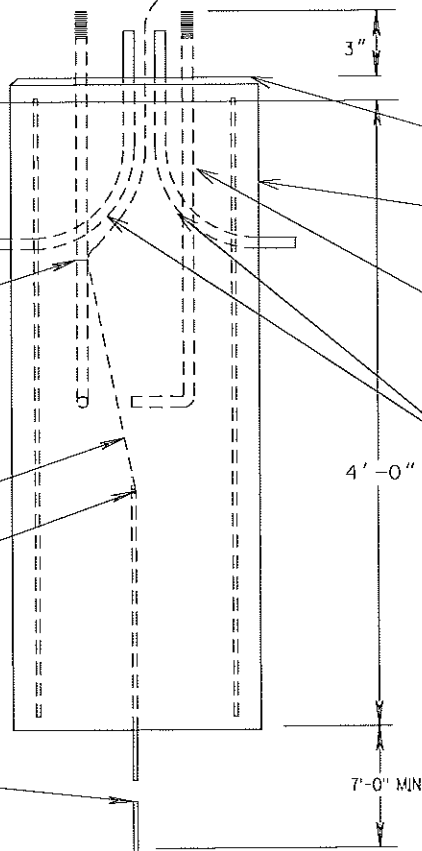

FORMS SHALL BE OF SUFFICIENT DEPTH  
TO PROVIDE A MINIMUM OF 12" OF FORMED  
BASE BELOW GRADE ON LOW SIDE.

3/4" X 24" ANCHOR BOLTS WITH 3"  
OF THREAD AT TOP AND 4" L-BEND  
AT BOTTOM.

INSTALL PVC ELBOWS OUT OF  
EACH SIDE OF THE BASE AS NEEDED

2013

CITY OF MADISON  
TRAFFIC ENGINEERING DIVISION

LB-9  
BASE DETAIL

STANDARD DETAIL DRAWING 6.45

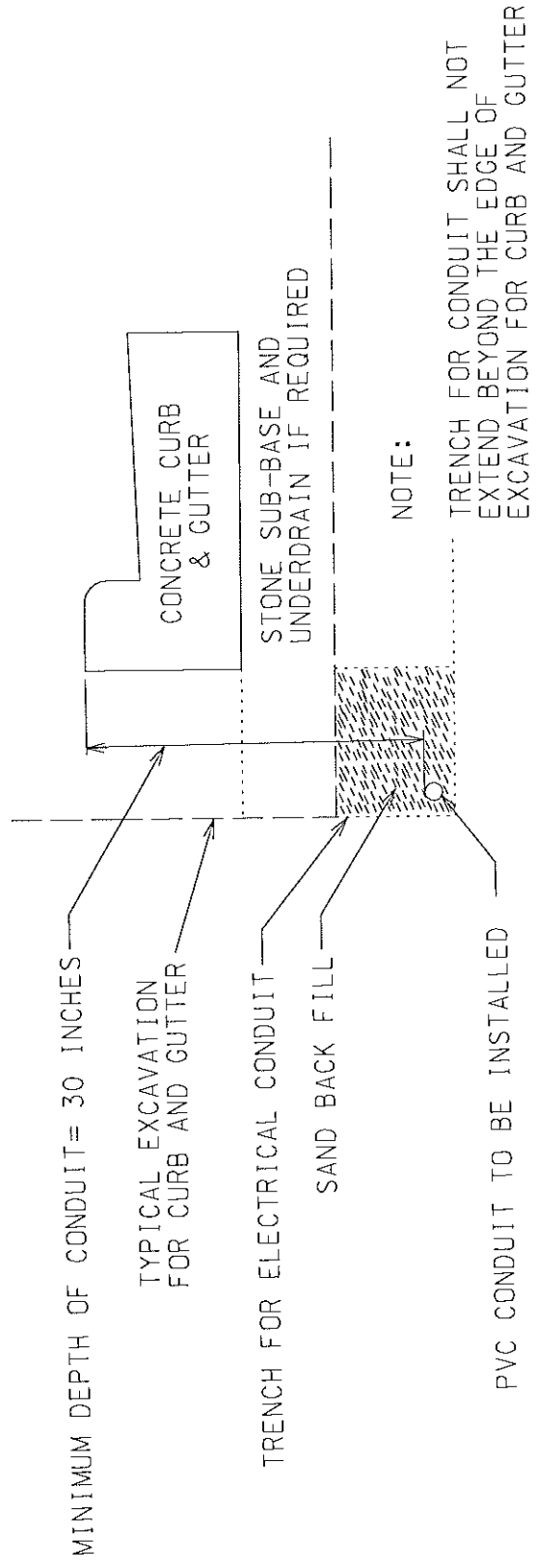

2013

CITY OF MADISON  
TRAFFIC ENGINEERING DIVISION

TYPICAL CONDUIT INSTALLATION  
PARALLEL TO CURB AND GUTTER

STANDARD DETAIL DRAWING 6.46

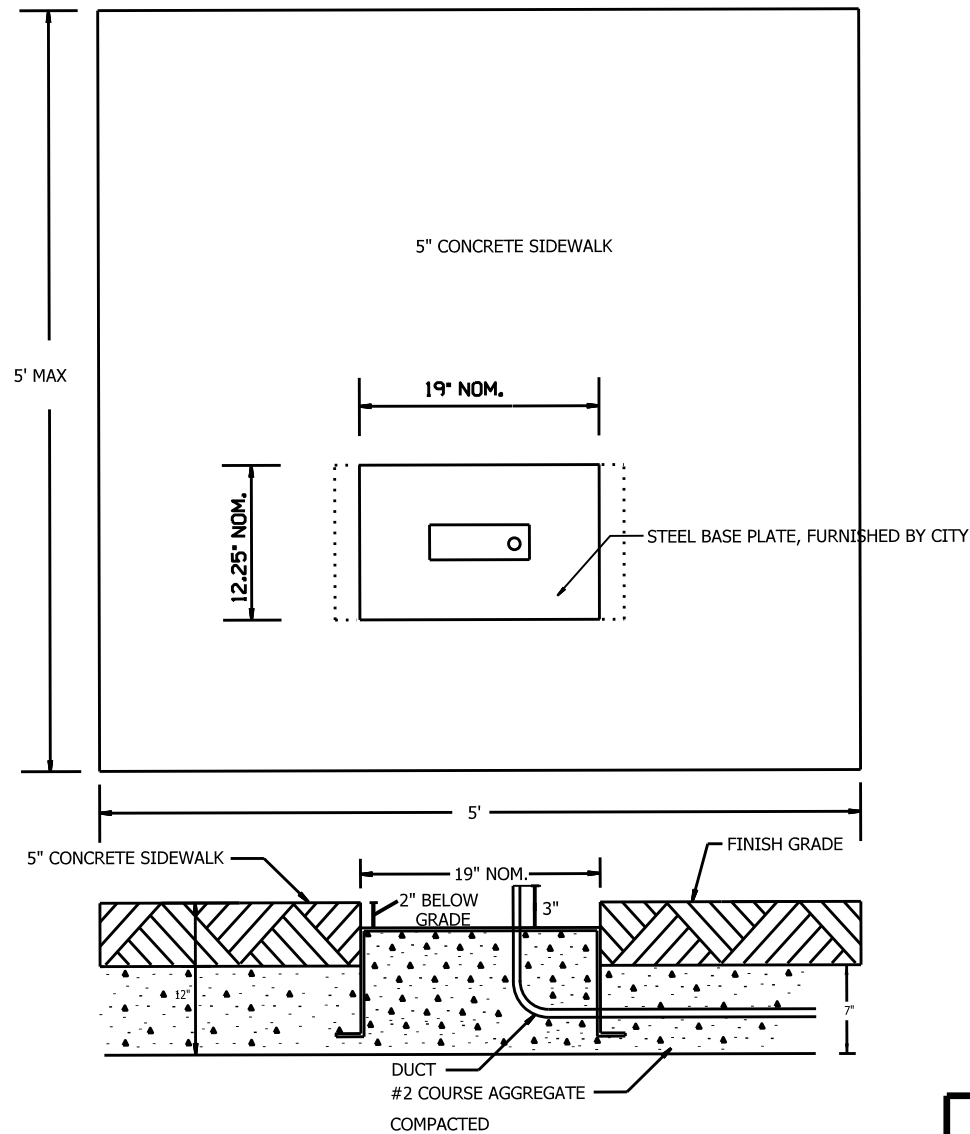

- NOTE:**
1. AGGREGATE SHALL BE FIRMLY COMPACTED AROUND BASE.
  2. TOP SURFACE OF STEEL BASE PLATE SHALL BE CLEAR OF CONCRETE.

**MULTISPACE PARKING  
METER BASE DETAIL**

2013

CITY OF MADISON  
TRAFFIC ENGINEERING DIVISION

MULTISPACE PARKING  
METER BASE DETAIL

STANDARD DETAIL DRAWING 6.47

7.01

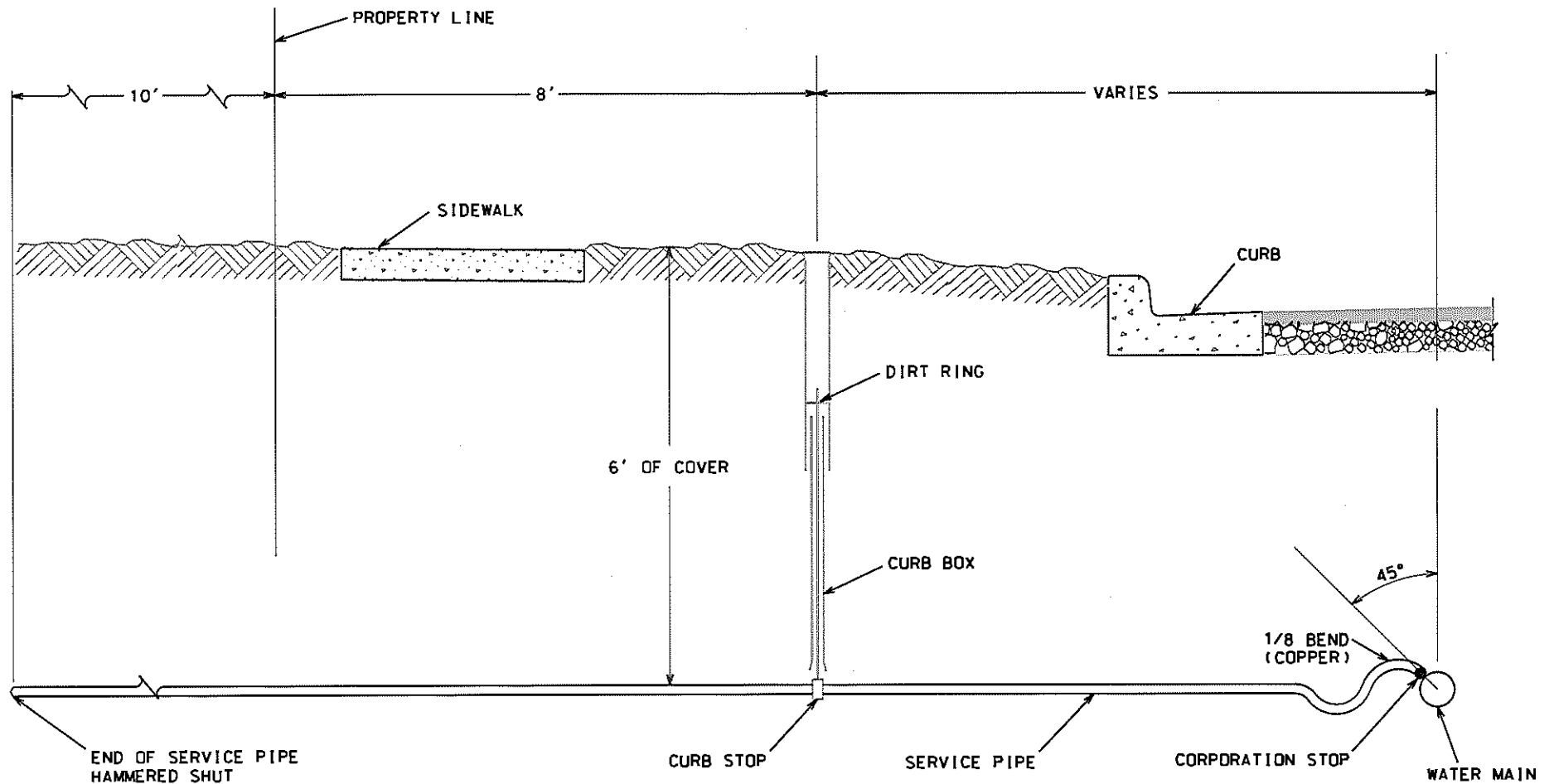

**NOTE:**

ON CUL-DE-SACS WITH NO SIDEWALKS,  
WATER SERVICE PIPE TO END AT  
PROPERTY LINE.

REVISED 1/2009

2004

CITY OF MADISON  
WATER UTILITY

SERVICE INSTALLATION  
PRIVATE CONTRACT

STANDARD DETAIL DRAWING 7.01



RESTRAINED JOINT  
(USING THREADED ROD)

FITTING TO FITTING RODS:

$\frac{3}{4}$ " 304 STAINLESS STEEL RODS  
AND NUTS. MAXIMUM LENGTH = 10'.

MECHANICAL JOINT  
RESTRAINT

FITTING OR  
STRAIGHT PIPE.

$\frac{3}{4}$ " 304 STAINLESS STEEL  
RODS AND NUTS, TYPICAL

CITY OF MADISON WATER UTILITY
STANDARD THREADED RODS
STANDARD DETAIL DRAWING 7.02

REVISED 1/2008

7.02

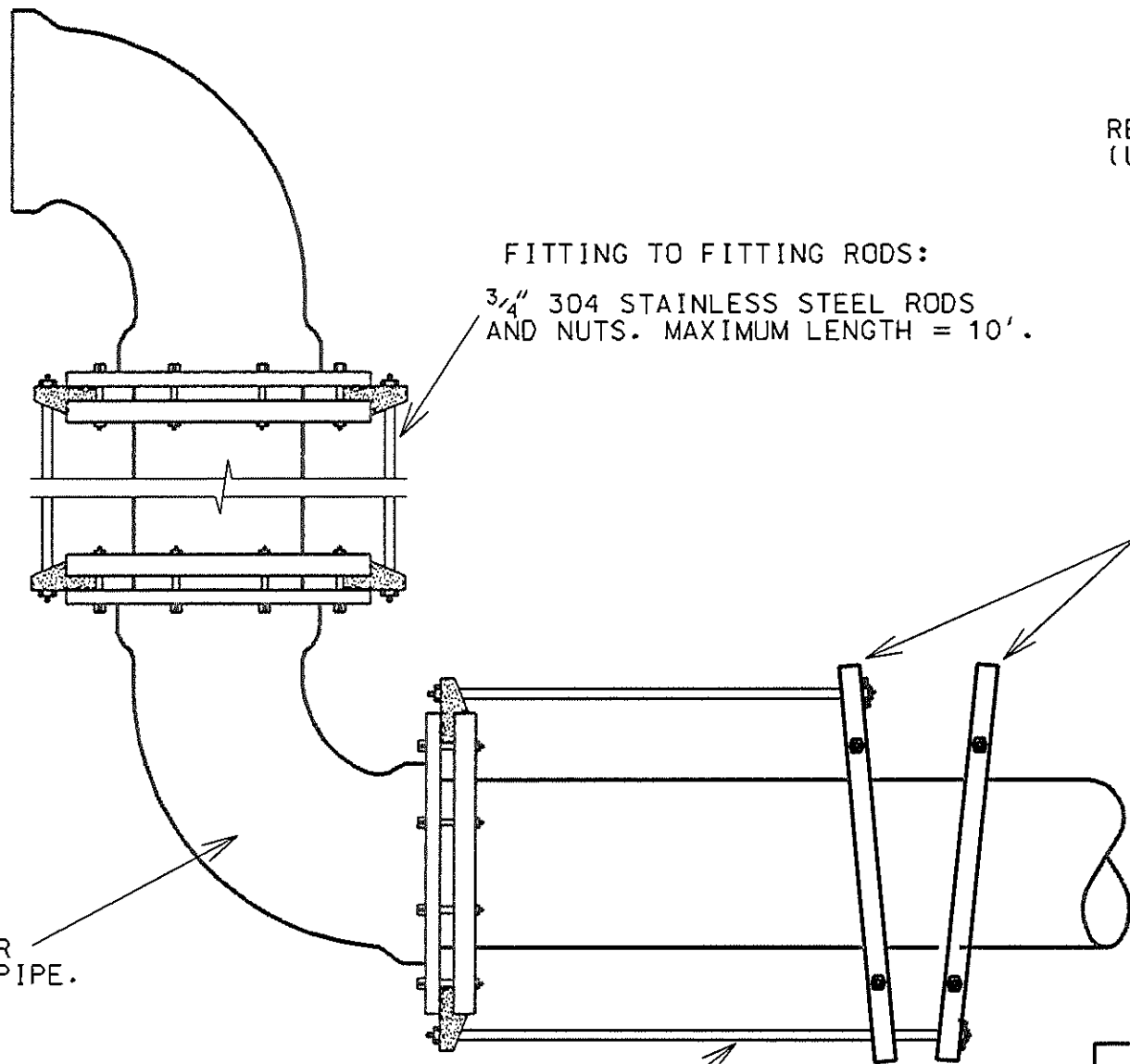

REQUIRED BEARING AREA  
PER STANDARD SPECIFICATION  
SECTION 703

TEE



HYDRANT

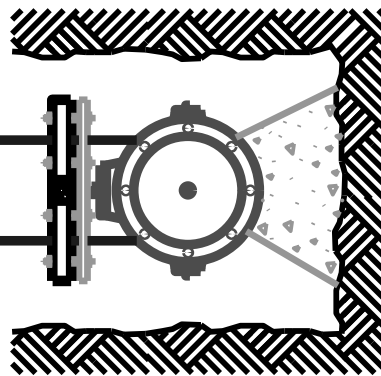

PLUGGED CROSS

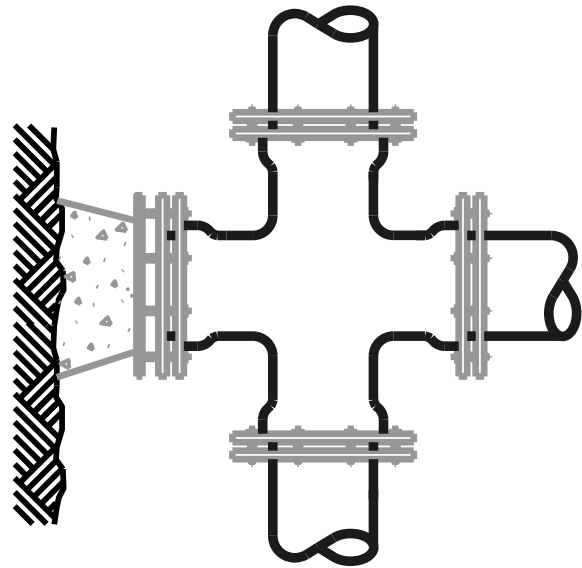

PLUGGED TEE

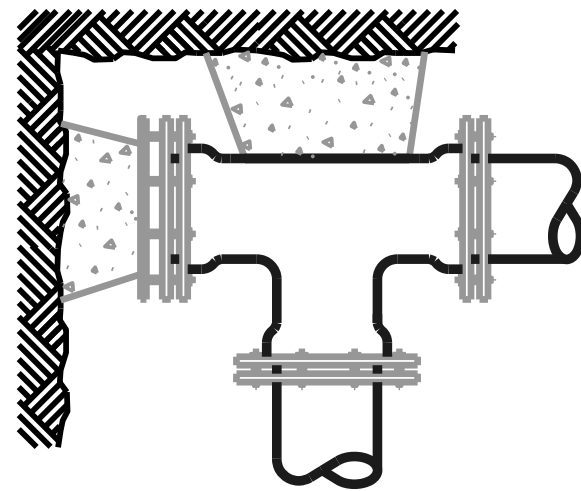

BENDS

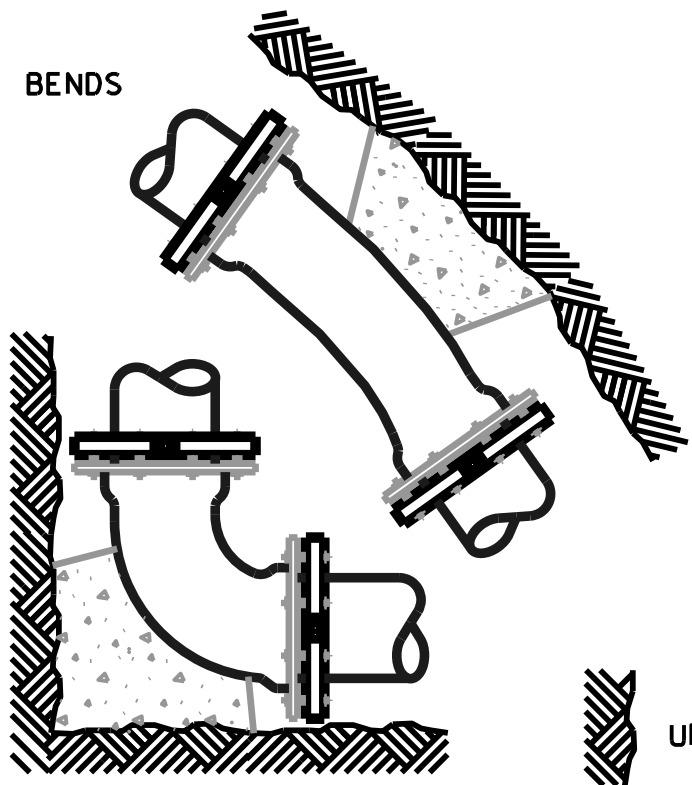

UNDISTURBED SOIL

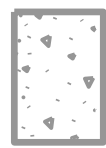

POURED CONCRETE

CITY OF MADISON  
WATER UTILITY

STANDARD CONCRETE  
BLOCK THRUST  
RESTRAINT

STANDARD DETAIL DRAWING 7.03 (A)

VOLUME RO'MNT FOR VERTICAL DOWN BENDS (C.Y.)				
FITTING SIZE (IN)	90° BEND	45° BEND	22.5° BEND	11 <sup>1</sup> / <sub>4</sub> ° BEND
4	0.7	0.5	0.3	0.1
6	1.6	1.1	0.6	0.3
8	2.8	2.0	1.1	0.6
10	4.4	3.1	1.7	0.9
12	6.4	4.5	2.4	1.2
16	11.3	8.0	4.3	2.2
20	17.7: 3 BARS	12.5: 3 BARS	6.8	3.4
24	25.4: 6 BARS	18.0: 4 BARS	9.7	5.0

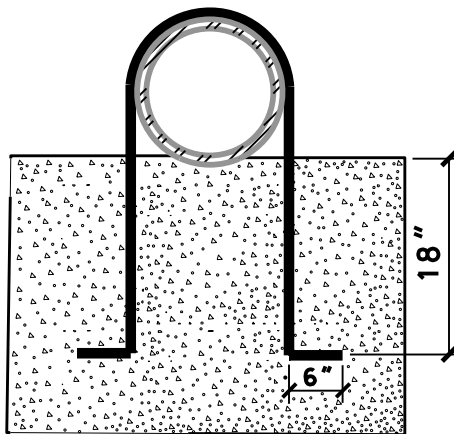

**CROSS SECTION**  
N T S

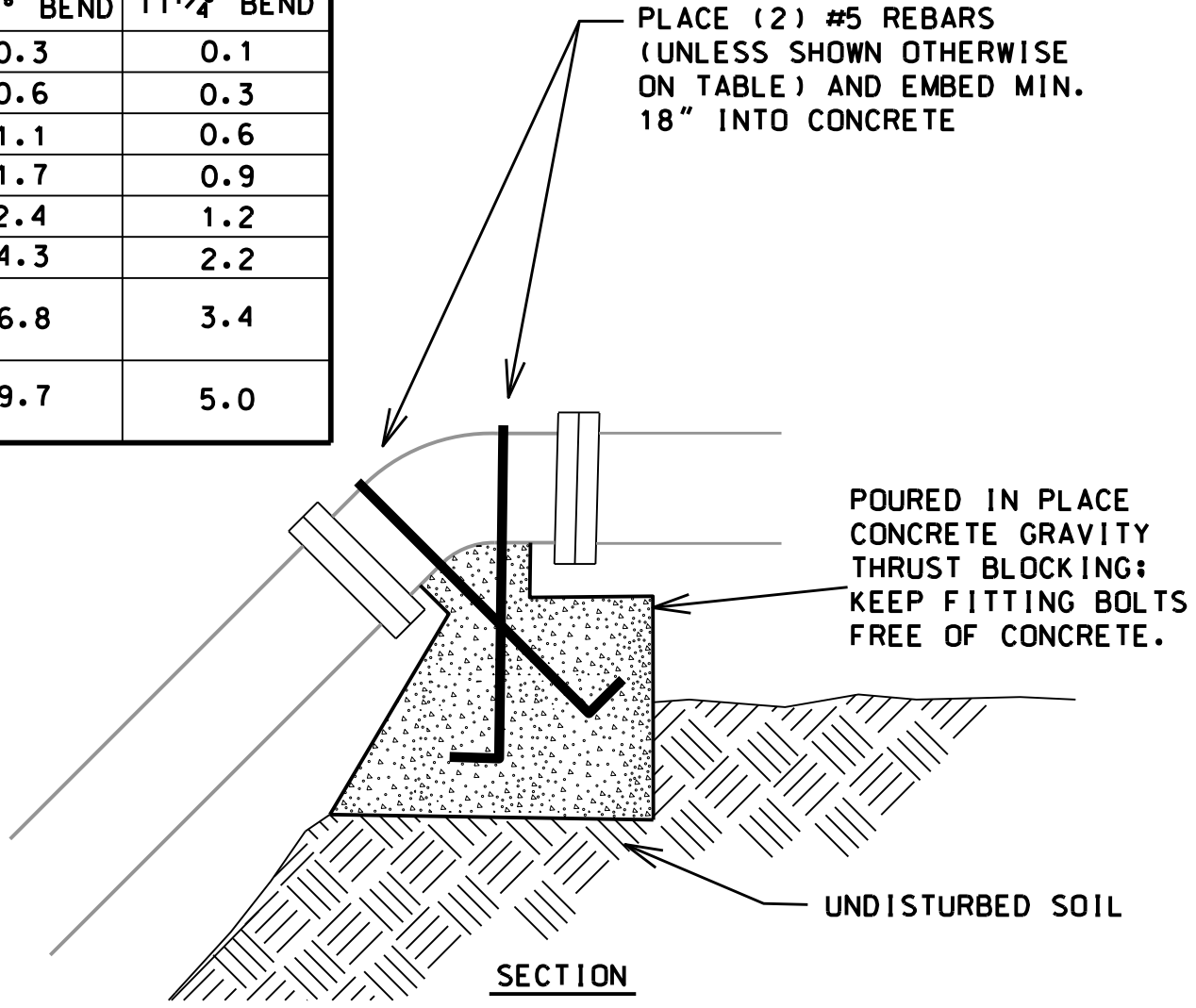

**SECTION**  
N T S

- NOTES:
- 1) REBAR SHALL BE #5 EXPOXY COATED GRADE 60
  - 2) CONCRETE SHALL BE MIN. 3,000 PSI COMPRESSIVE STRENGTH
  - 3) ABOVE VALUES ARE BASED ON 150 PSI TEST PRESSURE  
FOR OTHER TEST PRESSURES PROPORTION AS FOLLOWS:  
BLOCK VOLUME=TEST PRESSURE/150 X TABLE VALUE

CITY OF MADISON  
WATER UTILITY

**GRAVITY BLOCK THRUST  
RESTRAINT FOR  
VERTICAL DOWN BENDS**

STANDARD DETAIL DRAWING 7.03(B)

CONCRETE BLOCKING  
SIZED PER TABLE;  
ORIENTATION  
MAY BE HORIZONTAL  
OR VERTICAL

GRADE

6'  
TYP

(2) EVENLY SPACED (EXCEPT  
WHERE NOTED) 3/4" 304  
STAINLESS STEEL THREADED  
RODS WITH STAINLESS STEEL  
NUTS AND WASHERS

DUC LUGS OR  
PIPE CLAMPS

ALL JOINTS RESTRAINED  
BETWEEN VERTICAL  
FITTINGS

PIPE CLAMPS OR 1/2" X 3" X 3" PLATES  
W/ STAINLESS STEEL NUTS AND  
WASHERS ON BOTH SIDES.

VOLUME OF POURED CONCRETE BLOCKING (C.Y.) *				
FITTING SIZE (IN)	90° BEND	45° BEND	22.5° BEND	11.25° BEND
4	0.1	0.1	0.1	0.1
6	0.3	0.2	0.1	0.1
8	0.7	0.4	0.2	0.1
10	1.3	0.8	0.3	0.1
12	2.1	1.3	0.6	0.2
16	4.6	2.9	1.3	0.5
20	8.2 4 RODS	5.4 3 RODS	2.3	0.9
24	13.0 5 RODS	8.4 4 RODS	3.8	1.5

NOTE:

THIS METHOD MAY ONLY BE  
USED WHERE SPECIFIED OR  
WITH ENGINEER'S APPROVAL

N T S

\* CONCRETE SHALL  
BE MIN. 3000 PSI  
COMPRESSIVE STRENGTH

CITY OF MADISON  
WATER UTILITY

**ROD & CONCRETE BLOCK  
THRUST RESTRAINT  
FOR VERTICAL BENDS**

STANDARD DETAIL DRAWING 7.03(C)

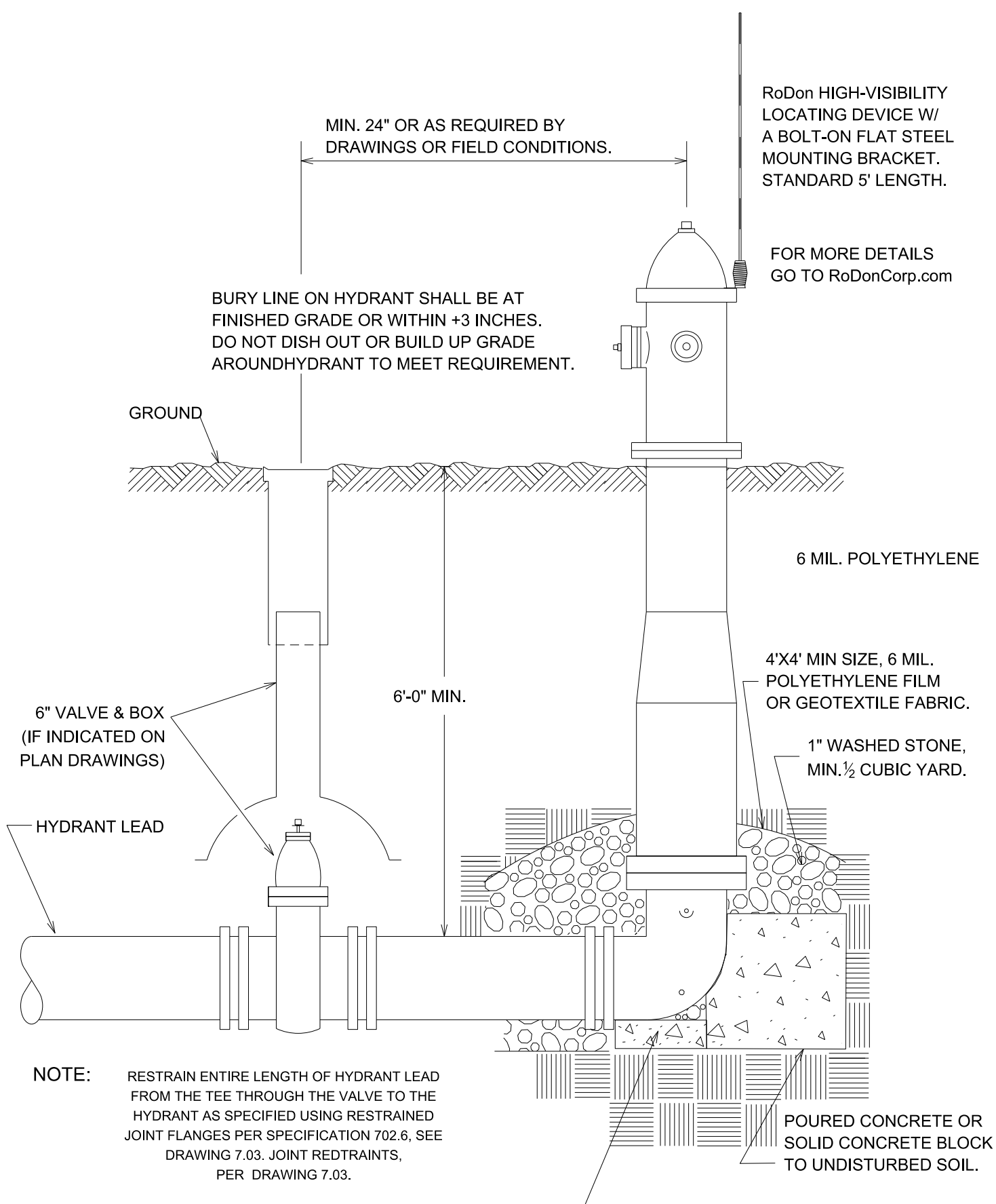

MIN. 24" OR AS REQUIRED BY DRAWINGS OR FIELD CONDITIONS.

RoDon HIGH-VISIBILITY LOCATING DEVICE W/ A BOLT-ON FLAT STEEL MOUNTING BRACKET. STANDARD 5' LENGTH.

FOR MORE DETAILS GO TO [RoDonCorp.com](http://RoDonCorp.com)

BURY LINE ON HYDRANT SHALL BE AT FINISHED GRADE OR WITHIN +3 INCHES. DO NOT DISH OUT OR BUILD UP GRADE AROUND HYDRANT TO MEET REQUIREMENT.

GROUND

6 MIL. POLYETHYLENE

4'X4' MIN SIZE, 6 MIL. POLYETHYLENE FILM OR GEOTEXTILE FABRIC.

1" WASHED STONE, MIN. 1/2 CUBIC YARD.

6" VALVE & BOX (IF INDICATED ON PLAN DRAWINGS)

6'-0" MIN.

HYDRANT LEAD

POURED CONCRETE OR SOLID CONCRETE BLOCK TO UNDISTURBED SOIL.

**NOTE:** RESTRAIN ENTIRE LENGTH OF HYDRANT LEAD FROM THE TEE THROUGH THE VALVE TO THE HYDRANT AS SPECIFIED USING RESTRAINED JOINT FLANGES PER SPECIFICATION 702.6, SEE DRAWING 7.03. JOINT REDTRAITS, PER DRAWING 7.03.

SOLID CONCRETE MASONRY UNIT

CITY OF MADISON WATER UTILITY

**TYPICAL HYDRANT INSTALLATION**

STANDARD DETAIL DRAWING 7.04

REVISED 12/2013

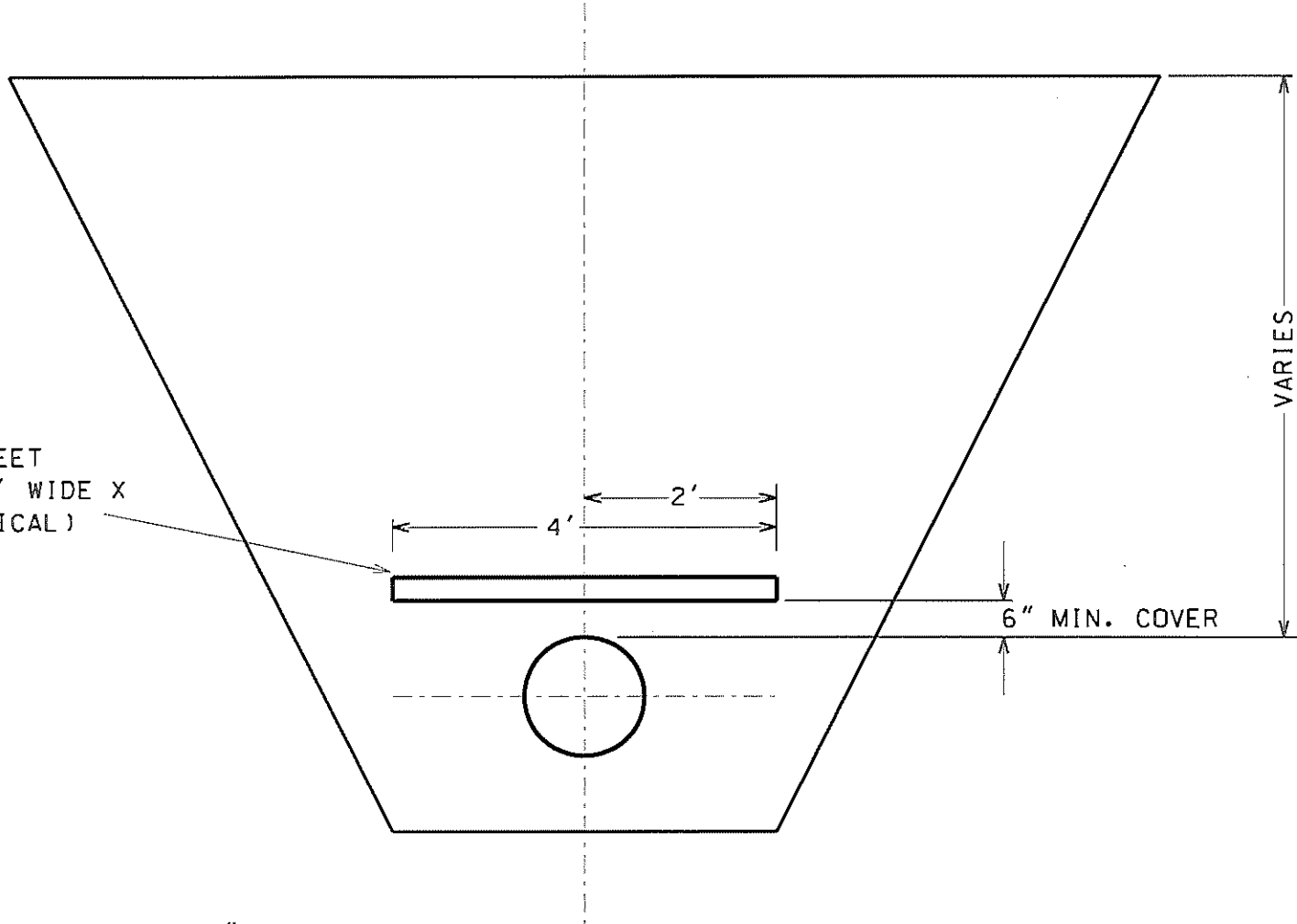

STYROFOAM SHEET  
2" THICK X 4' WIDE X  
8' LONG (TYPICAL)

NOTES:

- 1) ALL STYROFOAM TO BE 2" HIGH DENSITY POLYSTYRENE BOARD

CITY OF MADISON WATER UTILITY
TYPICAL STYROFOAM INSTALLATION
STANDARD DETAIL DRAWING 7.05



### METER PIT FITTING SPECS

FITTING	I. D.	SIZE	RADIUS	RUN
90 BEND	"N"	2"	6"	4.5"
90 BEND	"N"	3"	4"	3.5"
90 BEND	"N"	4"	4.5"	6.5"
90 BEND	"N"	6"	5"	8"
90 BEND	"N"	8"	7"	9"
90 BEND	"N"	10"	9"	11"
90 BEND	"N"	12"	10"	12"
90 BEND	"N"	14"	11.5"	14"
90 BEND	"N"	16"	12.5"	15"
90 BEND	"N"	18"	14"	16.5"
90 BEND	"N"	20"	15.5"	18"
90 BEND	"N"	24"	18.5"	22"
90 BEND	"N"	30"	21.5"	25"
90 BEND	"N"	36"	24.5"	28"
	I. D.	SIZE	BRANCH	RUN
TEE	"M"	1.5"	4.5"	4.5"
TEE	"M"	1.5"	5.5"	5.5"
TEE	"M"	2"	6.5"	6.5"
TEE	"M"	3"	8"	8"
TEE	"M"	4"	9"	9"
TEE	"M"	6"	11"	11"
TEE	"M"	8"	14"	14"
TEE	"M"	10"	15.5"	15.5"
TEE	"M"	12"	16.5"	16.5"
TEE	"M"	14"	18"	18"
TEE	"M"	16"	19.5"	19.5"
TEE	"M"	18"	21"	21"
TEE	"M"	20"	22.5"	22.5"
TEE	"M"	24"	25"	25"
TEE	"M"	30"	28"	28"
TEE	"M"	36"	28"	28"
	I. D.	SIZE	TYPE	RUN
VALVE	"P"	2"	RS GATE	7"
VALVE	"P"	3"	RS GATE	6"
VALVE	"P"	4"	RS GATE	9"
VALVE	"P"	6"	RS GATE	10.5"
VALVE	"P"	8"	RS GATE	11.5"
VALVE	"P"	10"	RS GATE	13"
VALVE	"P"	12"	RS GATE	14"
VALVE	"P"	14"	RS GATE	15"
VALVE	"P"	16"	RS GATE	20.25"
VALVE	"P"	18"	RS GATE	22"
VALVE	"P"	20"	RS GATE	22.75"
VALVE	"P"	24"	RS GATE	25.50"
VALVE	"P"	30"	RS GATE	28.75"
VALVE	"P"	36"	RS GATE	32"
	I. D.	SIZE		RUN
STRAINER	"S"	3"		7"
STRAINER	"S"	4"		9"
STRAINER	"S"	6"		9"
STRAINER	"S"	8"		14"
STRAINER	"S"	10"		16"
STRAINER	"S"	12"		18"

### METER PIT SIZES

Meter Size	3"	4"	6"	8"	10"
"A"	10'-0"	11'-0"	13'-0"	14'-8"	14'-8"
"B"	12'-0"	13'-0"	15'-0"	16'-8"	16'-8"
"C"	7'-0"	7'-0"	9'-0"	9'-0"	9'-0"

### COMPOUND METER SPECS

Meter Size	Meter Weight	Meter Lay Length	Strainer Lay Length	Flow Rate
3"	71.5 lbs	17"	7"	1/2" 450 GPM
4"	85 lbs	20"	9"	3/4" 1000 GPM
6"	152 lbs	24"	9"	3/4" 2000 GPM

### TURBINE METER SPECS

Meter Size	Meter Lay Length	Turbine Meter-GPM	Max. Cont. Duty	Strainer Lay Length
2"	10"	4 - 310	200 GPM	7"
3"	12"	5 - 550	450 GPM	7"
4"	14"	10 - 1250	1000 GPM	9"
6"	18"	20 - 2500	2000 GPM	9"
8"	20"	30 - 4500	3000 GPM	14"
10"	26"	50 - 7000	5500 GPM	16"

### MAG METER SPECS

Meter Size	Meter Lay Length	Mag Meter-GPM
2"	8.9"	1 - 373
2 1/2"	11"	2 - 631
3"	11"	3 - 956
4"	11"	5 - 1493
6"	15.8"	11 - 3361
8"	15.8"	20 - 5975
10"	19.7"	30 - 9336
12"	19.7"	45 - 13444
14"	23.6"	60 - 18299
16"	23.6"	80 - 23901
18"	23.6"	100 - 30250
20"	23.6"	125 - 37346
22"	23.6"	150 - 45188
24"	23.6"	180 - 53778
28"	23.6"	240 - 73100
30"	31.5"	280 - 84000
32"	31.5"	320 - 95600
36"	31.5"	400 - 121000

For more info see:  
[www.bodgermeter.com](http://www.bodgermeter.com)

REV 1/23/08



## WATER METER PIT SPECIFICATIONS:

1. DIMENSIONS: See Attached Drawings.
2. COMPOUND METER SPECIFICATIONS: See Attached Drawings.
3. TURBINE METER SPECIFICATIONS: See Attached Drawings.
4. Specifications for new pits: Meter pits shall conform to the attached diagrams and tables.
5. (a) 'Material'. The meter pit shall be constructed of reinforced poured concrete thoroughly puddled in place. The concrete shall conform to Section 611 of Wisconsin standard specifications, as shown on the plans and as specified.  
(b) 'Waterproof Juncture'. The junctions of the floors, walls and roof shall be made waterproof by the use of water stops or keyed joints. Conduit or similar connections within the pit shall be waterproof. Meter pit shall be 100% water proof. Rubberized membrane shall be required on the entire exterior of the structure. Refer to Section 516 of the Wisconsin standard specs.  
(c) 'Reinforcement'. The deck or pit roof shall be reinforced with steelbars to insure strength and durability.  
(d) 'Manhole and Catch Basin'. To be located as shown on attached drawing.  
(e) 'Manhole Covers'. An approved watertight cast iron manhole frame and bolt down cover with a gasket.  
(f) If a sump pump is required, the contractor will install electric and provide sump pump and drainage.  
(g) Armored and explosion proof light switches and lights shall be installed.

## METER INSTALLATION

1. A Strainer is REQUIRED to insure optimum flow conditioning and protection for the Badger Series meter-measuring element, supplied by the Madison Water Utility.
2. Badger meters, with a strainer, REQUIRE a minimum of five (5) pipe diameters of straight pipe up stream of meter.

3. ONLY full-open gate valves should be used immediately upstream of the meter, and valves SHALL be located at least five (5) pipe diameters or more upstream of meter. Full open gate valves or butterfly valves (16" or larger) may be used downstream.
4. DO NOT install pressure-reducing valves downstream of the meter.
5. A check valve must be installed downstream of the meter to prevent surging.
6. Weighted check valves SHALL be located at least three (3) pipe diameters downstream of the meter.
7. Pressure reducing devices and externally weighted check valves SHALL be located at least five (5) pipe diameters downstream of meter.
8. All nuts and bolts shall be 304 stainless steel.

## METER PIT MAINTENANCE:

1. The water CUSTOMER shall be responsible for the maintenance and upkeep of the meter pit.
2. All pits shall be maintained in a clean, dry and safe condition.
3. If the pit has water problems the owner shall cause a sump pump to be installed, if power is not available a sump pit shall be constructed with a standpipe.
4. All pipes and plumbing shall be maintained in a safe functional condition.
5. Steps must be maintained so as to provide safe access.
6. Owner shall be responsible for entire cost to pump out flooded pit.

## NOTES:

1. A bypass is required, may be one size smaller than meter.
2. Standard companion valves and flanges shall be used.
3. No insulation or covering on meters and valves.
4. No PVC piping allowed.
5. Waterproofing shall be required on exterior of structure, including all penetrations into the vault.
6. All piping shall be supported from the floor or walls as necessary with rust proof metal. No brick, wood or concrete blocking will be allowed.
7. Water meter pit is the responsibility of the customer.
8. Meter and strainer shall be installed per manufacturer's instructions. Refer to meter detailsheets for additional information. Meter and strainer to be provided by the Madison Water Utility and installed by the contractor.
9. Size of valves shall not be smaller than the size of the meter.
10. When a check valve is installed proper expansion protection shall be installed.
11. Backfill structure evenly on all sides with suitable material approved by the Engineer.

For more info see:  
[WWW.badgermeter.com](http://WWW.badgermeter.com)

REV 1/23/08

NOTES

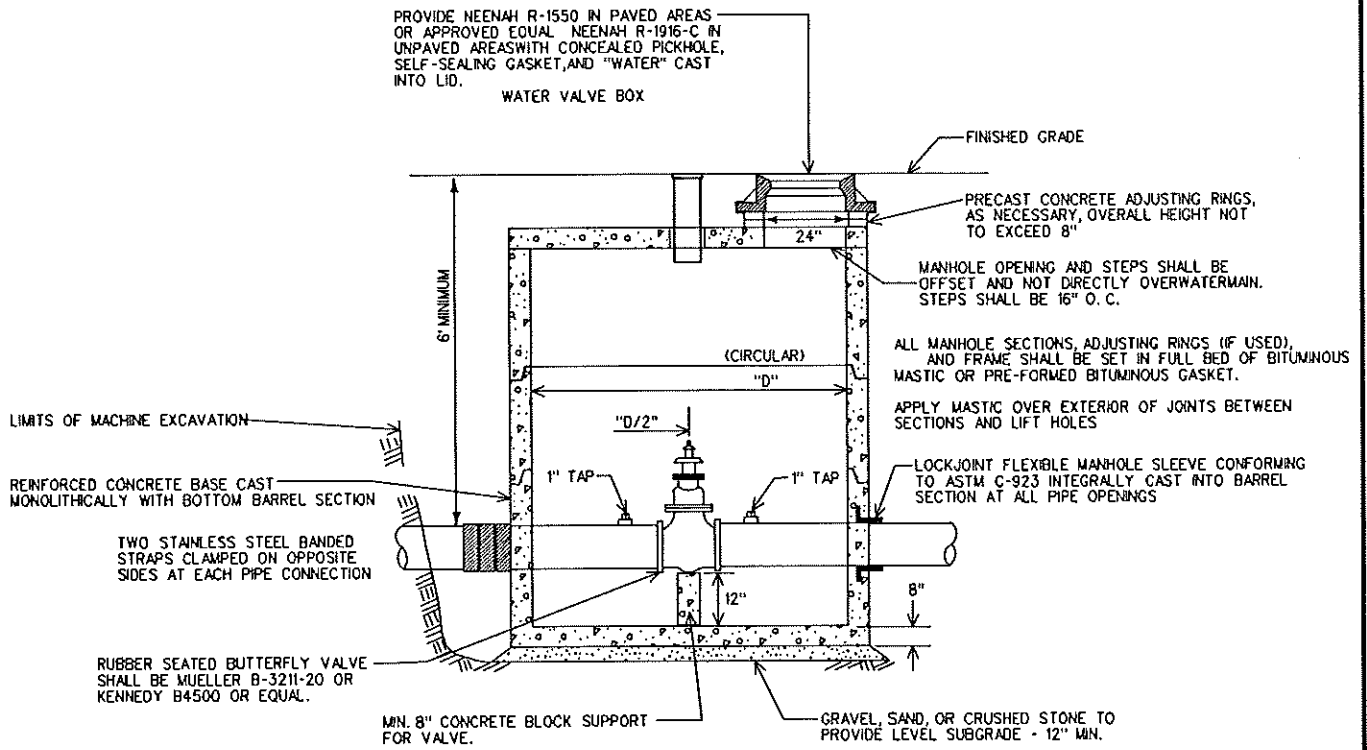

WATER VALVE MANHOLE

NTS

NOTES:

1. DIMENSION "D" SHALL BE 48" WHEN WATERMAIN IS LESS THAN 10" IN DIAMETER, 60" WHEN DIAMETER OF MAIN IS 10" OR 12", 72" WHEN DIAMETER OF MAIN IS 14" OR 16", AND 84" WHEN DIAMETER OF MAIN IS 18" OR LARGER.
2. THE CONTRACT UNIT PRICE FOR "WATER VALVE MANHOLE" SHALL INCLUDE THE COST OF FURNISHING AND PLACING 6" LEVELING BASE AS SPECIFIED, AND THE COST OF FURNISHING AND PLACING THE SPECIFIED FRAME AND COVER.
3. VALVE BOX SHALL BE ALIGNED OVER OPERATING NUT SO THAT VALVE CAN BE KEYS WITHOUT TWIST OR TORQUE.
4. MANHOLE SHALL BE WATER TIGHT.

CITY OF MADISON  
WATER UTILITY

WATER MAIN VALVE  
ACCESS STRUCTURE

STANDARD DETAIL DRAWING 7.07

PIPE SIZE	NO. OF FLEX RESTRAINTS
6"	2
8"	2
12"	3
16"	4

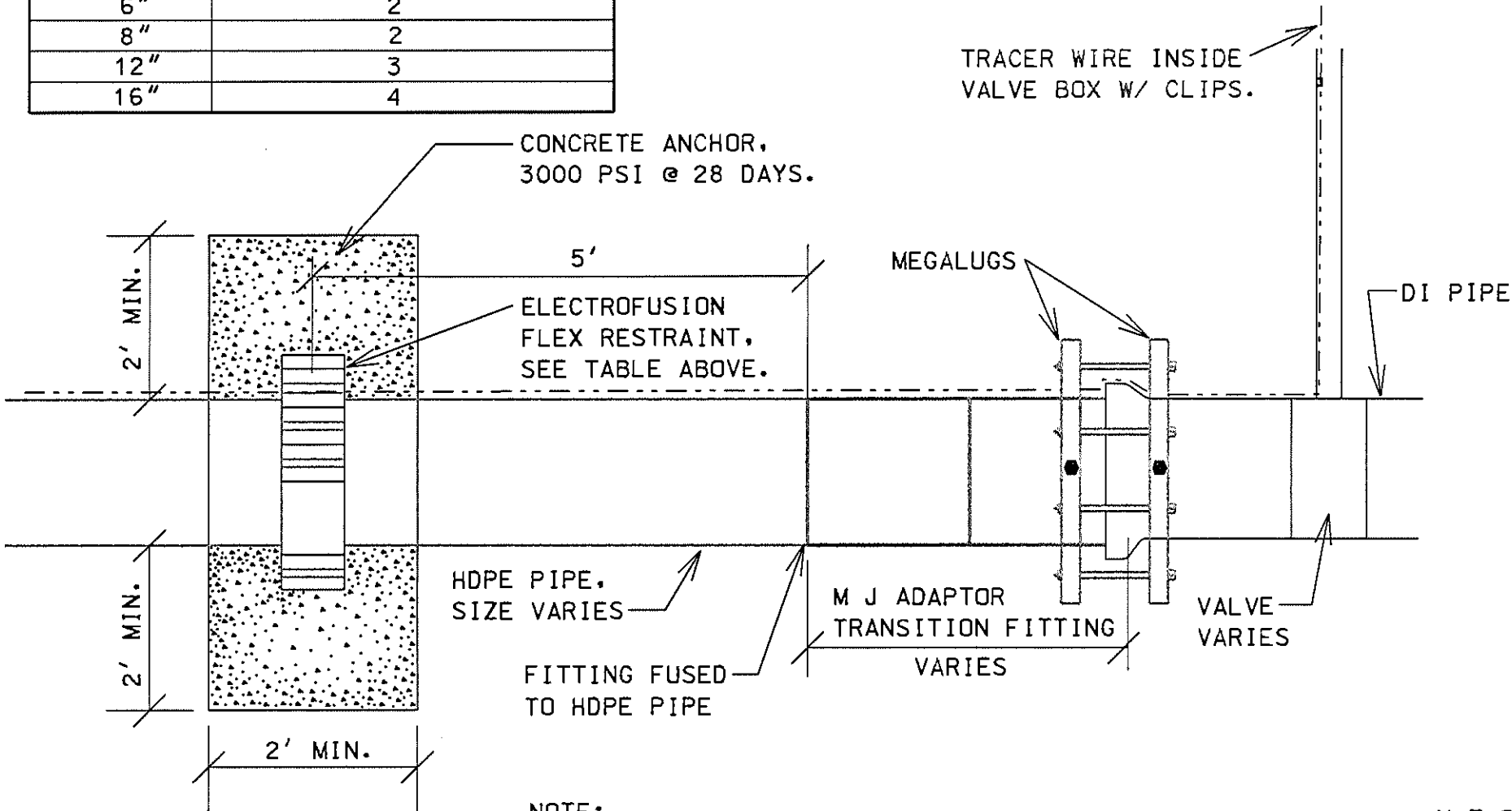

7.08

NOTE:  
 CONCRETE ANCHOR TO COMPLY W/  
 ARTICLE 301 IN THE STANDARD SPECS.

SEE PIPE MANUFACTURERS STANDARDS  
 FOR ADDITIONAL INFORMATION, FIELD  
 ENGINEER MUST APPROVE VARIANCES.

N T S

CITY OF MADISON WATER UTILITY
<b>STANDARD HDPE PIPE RESTRAINTS</b>
STANDARD DETAIL DRAWING 7.08

7.09

DUCTILE IRON WATER MAIN,  
12" PIPE MAX. USING TIMBER  
SPACERS. SEE NOTE BELOW.

STEEL CASING,  
SIZE VARIES.

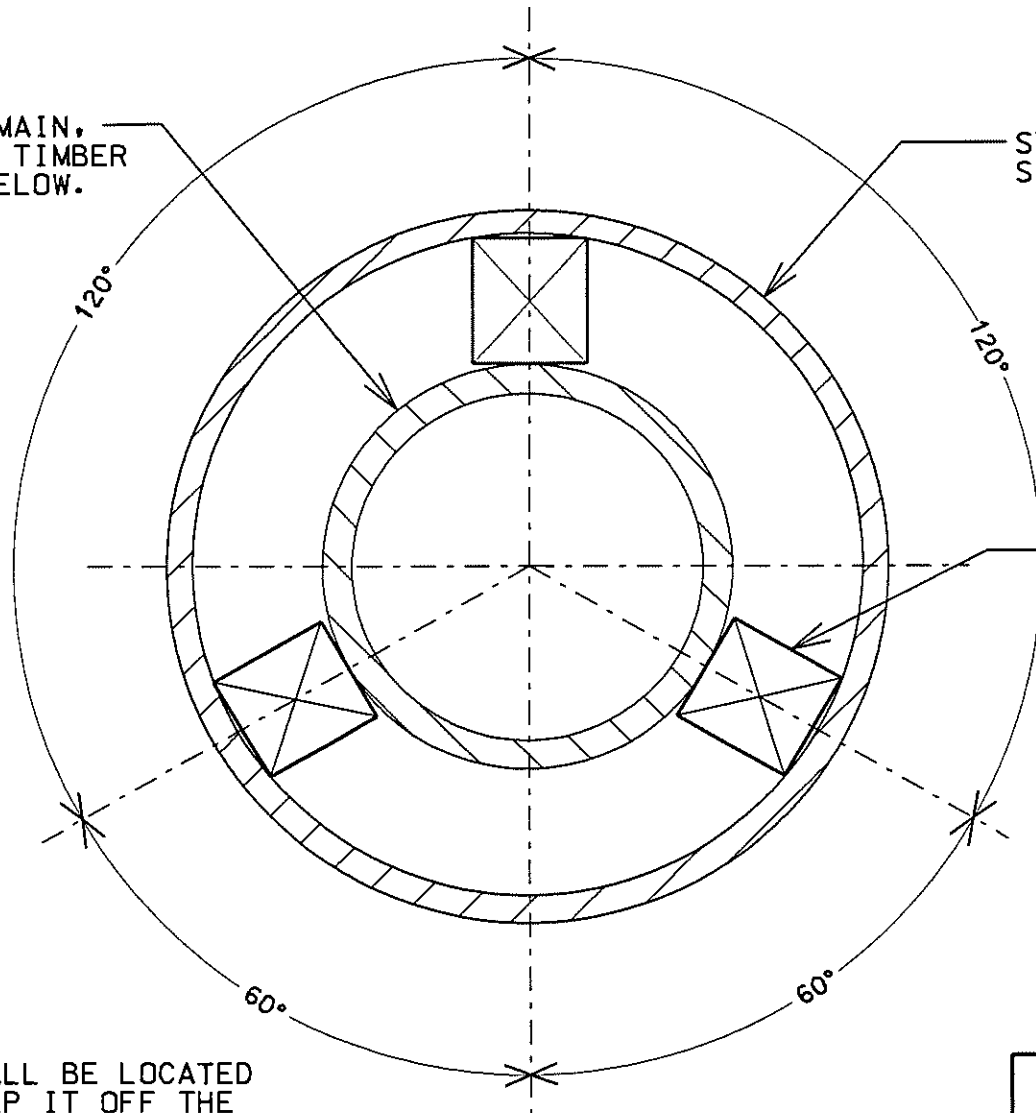

4"X4" SPACERS,  
MIN. 4' LONG  
STRAPPED TO PIPE.  
MIN. 3 STRAPS PER  
LOCATION

**NOTES:**

- TIMBER SPACERS SHALL BE LOCATED NEAR THE BELL TO KEEP IT OFF THE CASING.
- TIMBER SPACERS SHOULD ONLY BE USED FOR CASINGS UP TO 60' LONG. FOR LONGER LENGTHS AND BIGGER PIPE, APPROVED MANUFACTURED CASING SPACERS WILL BE REQUIRED.

N T S

1/2012 TLR

CITY OF MADISON WATER UTILITY
<b>CASING SPACERS</b>
STANDARD DETAIL DRAWING 7.09

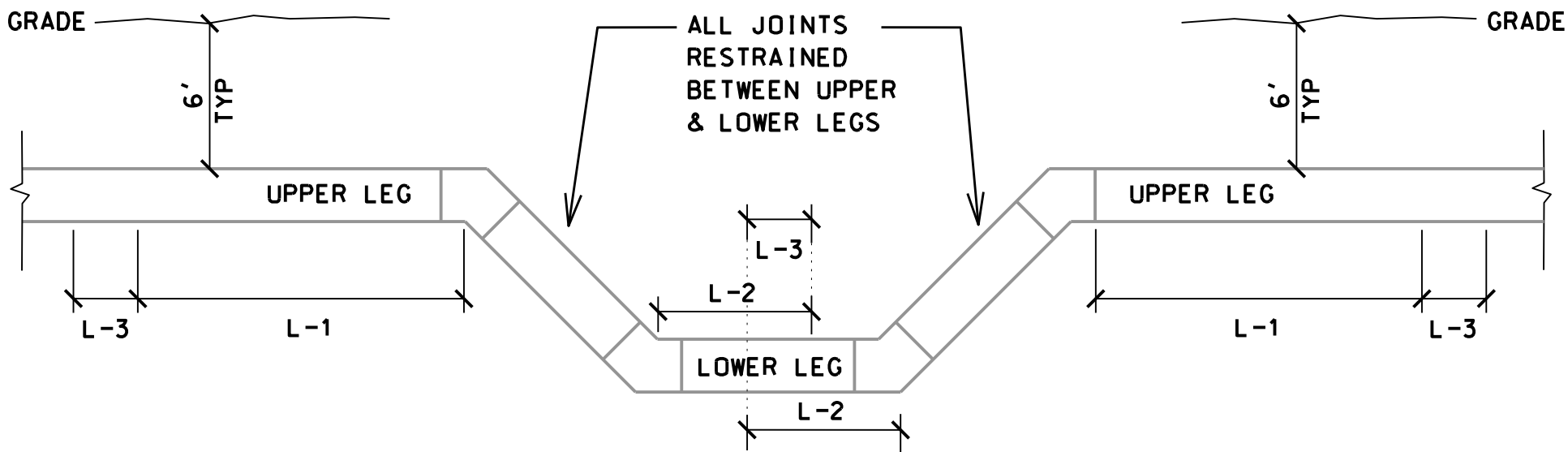

FITTING SIZE (IN)	90° BEND		45° BEND		22.5° BEND		11.25° BEND	
	L-1 (FT)	L-2 (FT)	L-1 (FT)	L-2 (FT)	L-1 (FT)	L-2 (FT)	L-1 (FT)	L-2 (FT)
4	30	30	13	3	6	2	3	1
6	43	43	18	4	9	2	5	1
8	56	56	24	5	12	3	6	2
10	68	68	28	6	14	3	7	2
12	80	80	34	7	16	4	8	2
16	104	104	43	10	21	5	11	3
20	128	128	53	12	26	6	13	3
24	150	150	63	13	30	7	15	4

L-1: RESTRAINED JOINT LENGTH UPPER LEG OF VERTICAL BEND

L-2: RESTRAINED JOINT LENGTH LOWER LEG OF VERTICAL BEND

L-3: L-2 OVERLAP: WHERE L-3 EXISTS L-3 IS ADDED TO L-1

NOTES:

SOURCE: EBAA Iron Restraint Length Calculator, Version 6.3  
 Material=Poly Wrapped Ductile Iron Pipe  
 Soil Type=GM (Silty Gravels, Gravel-Sand-Silt Mixtures)  
 Test Pressure = 150 PSI

Safety Factor = 1.5  
 Trench Type = 4  
 High Side Depth = 6'  
 Low Side Depth = 8'

CITY OF MADISON WATER UTILITY
<b>JOINT RESTRAINT LENGTHS FOR VERTICAL BENDS</b>
STANDARD DETAIL DRAWING 7.10

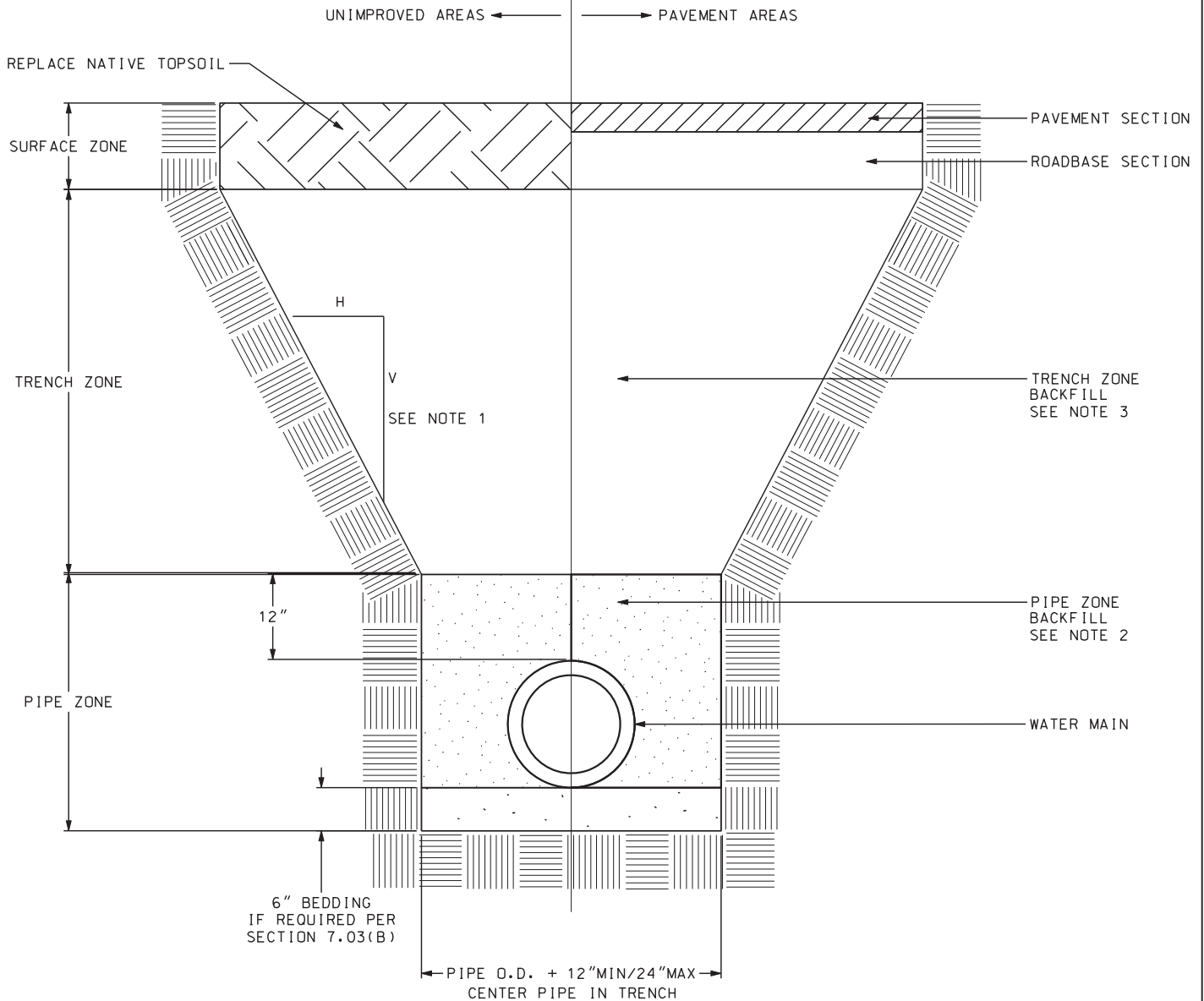

**NOTES:**

- 1) ALL EXCAVATION SHALL BE IN ACCORDANCE WITH THE WISCONSIN ADMINISTRATIVE CODE FOR "TRENCH EXCAVATION, AND TUNNEL CONSTRUCTION" AND ANY ADDITIONAL REQUIREMENTS INCLUDED IN THE CONTRACT DOCUMENTS.
- 2) BACKFILL OPERATIONS SHALL COMPLY WITH SECTION 703.8 AND SUBSECTION 202.2(B). THE PIPE ZONE SHALL CONSIST OF SELECT FILL SAND, LIMESTONE SCREENINGS, WASHED OR CLEAR STONE, GRAVEL OR CRUSHED STONE.
- 3) BACKFILL OPERATIONS FOR THE TRENCH ZONE SHALL COMPLY WITH SECTION 703.11.
- 4) COMPACTION REQUIREMENTS:  
 PIPE ZONE: COMPACT BEDDING MATERIAL USING A HAND OPERATED MECHANICAL COMPACTOR.  
 FROM 2' OVER PIPE TO 3' BELOW SUBGRADE: MINIMUM OF 90% OF MAX DENSITY.  
 WITHIN 3' OF BOTTOM OF SUBGRADE: MINIMUM OF 95% OF MAX DENSITY

CITY OF MADISON WATER UTILITY
<b>TYPICAL WATER PIPE TRENCH</b>
STANDARD DETAIL DRAWING 7.11

## OFFSETTING EXISTING WATER MAIN UNDER UTILITY CONFLICTS

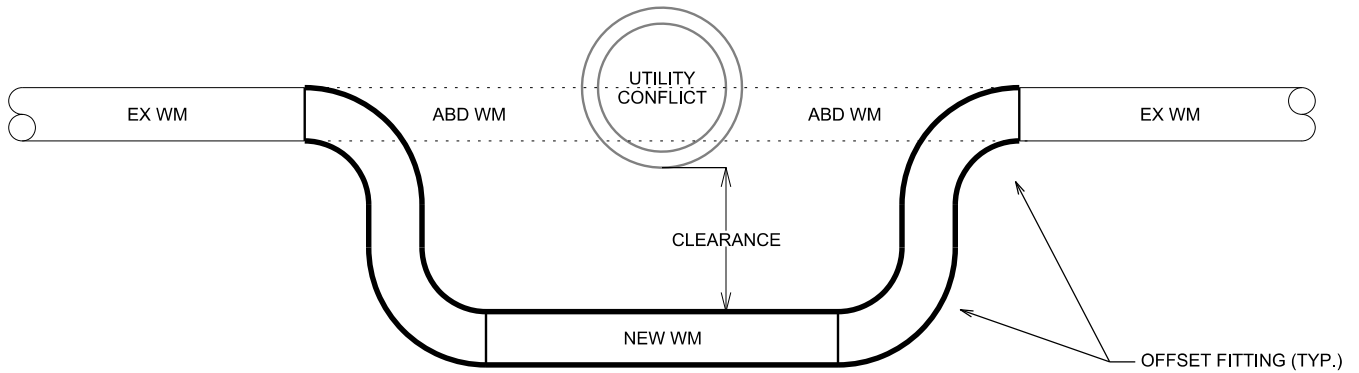

**NOTES:**

- 1) CLEARANCE SHALL BE PER STANDARD SPECIFICATIONS
- 2) IF REQUIRED CLEARANCE CANNOT BE OBTAINED, USE 45° FITTINGS IN LIEU OF OFFSET FITTINGS
- 3) 11.25°, 22.5°, OR 90° FITTINGS NOT ALLOWED WITHOUT APPROVAL
- 4) INSULATE AS REQUIRED PER STANDARD SPECIFICATIONS
- 5) FITTINGS CONNECTED TO EX WM WITH CUT-IN CONNECTIONS PER STANDARD SPECIFICATIONS
- 6) NEW PIPE SHALL HAVE NO JOINTS BETWEEN FITTINGS

## OFFSETTING EXISTING WATER MAIN OVER UTILITY CONFLICTS

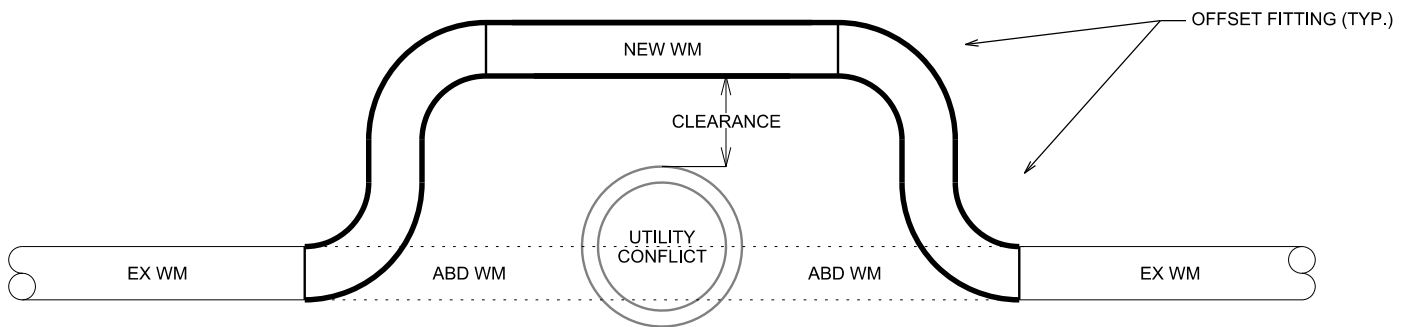

**NOTES:**

- 1) CLEARANCE SHALL BE PER STANDARD SPECIFICATIONS
- 2) IF REQUIRED CLEARANCE CANNOT BE OBTAINED, USE 45° FITTINGS IN LIEU OF OFFSET FITTINGS
- 3) 11.25°, 22.5°, OR 90° FITTINGS NOT ALLOWED WITHOUT APPROVAL
- 4) INSULATE AS REQUIRED PER STANDARD SPECIFICATIONS
- 5) FITTINGS CONNECTED TO EX WM WITH CUT-IN CONNECTIONS PER STANDARD SPECIFICATIONS
- 6) NEW PIPE SHALL HAVE NO JOINTS BETWEEN FITTINGS

CITY OF MADISON WATER UTILITY
<b>OFFSETTING EXISTING WATER MAIN</b>
STANDARD DETAIL DRAWING 7.12