

SIDE VIEW

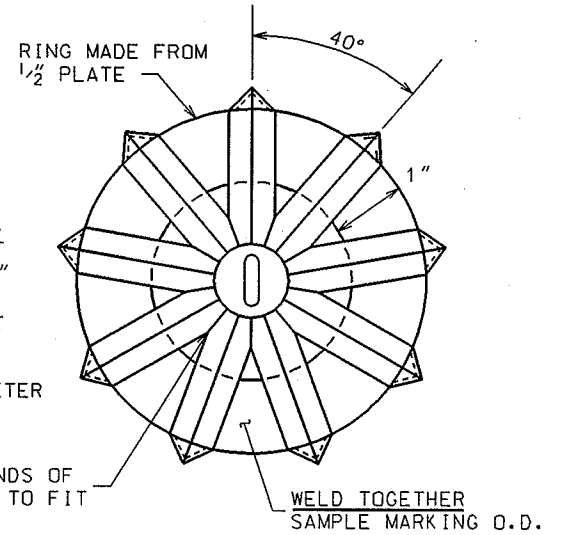

END VIEW

NOMINAL PIPE SIZE ID, in	DIMENSIONS		MANDRELL O.D., in	RING O.D., in
	A, in	B, in		
6	4.0	4	5.61	4.90
8	5.3	6	7.36	6.65
10	6.7	6	9.21	8.50
12	8.0	8	11.06	10.35
15	10.0	9	13.82	13.11

MANDREL FOR USE IN ALL P.V.C. SEWER PIPE

NOTE:

AFTER CONSTRUCTION IS COMPLETE, TRUE THE O.D. DIMENSION FOR THE FULL LENGTH OF "B" TO +/-0.010" BY TOOL AND LATHE OR GRINDING.

2004

CITY OF MADISON  
ENGINEERING DIVISION

MANDREL DETAIL

STANDARD DETAIL DRAWING 5.1.1