



Madison, Wisconsin

CITY OF MADISON

CITY ENGINEERING DIVISION

DEPARTMENT OF PUBLIC WORKS

PLAN OF PROPOSED IMPROVEMENT

501 CHARMANY DRIVE (ENDEAVOR LANE)

CITY PROJECT NO. 11847
CONTRACT NO. 8166

REVISION 4/5/19 AJZ
- Add Sanitary Sewer Exhibits
REVISION 10/28/19 AJZ
- Add Private Lighting Plans

PUBLIC IMPROVEMENT PROJECT APPROVED
May 15, 2018

BY THE COMMON COUNCIL OF MADISON, WISCONSIN

PUBLIC IMPROVEMENT DESIGN APPROVED BY:

[Signature] 2/28/19
City Engineer Date

INDEX OF SHEETS

SHEET NO.	TITLE
SHEET NO. 1	STANDARD NOTES & COMMENTS
SHEET NO. D1	TYPICAL SECTIONS
SHEET NO. D2	STORM STRUCTURE DETAIL
SHEET NO. D3	PLANTER LAYOUT AND DETAILS
SHEET NO. PLNT1-PLNT3	ENDEAVOR LANE PLAN & PROFILE
SHEET NO. PI-P2	WHITNEY WAY PLAN
SHEET NO. PL1	CHARMANY DRIVE PLAN
SHEET NO. PL2	SEWER PLAN & PROFILE
SHEET NO. U1-U3	STORM SEWER SCHEDULE
SHEET NO. U4	SANITARY SEWER EXHIBITS
SHEET NO. EX1-EX4	WATER PLAN & PROFILE
SHEET NO. W1-W2	WATER ESTIMATE OF MATERIALS
SHEET NO. W3	ELECTRICAL PLANS (STREET LIGHTS)
SHEET NO. E1-E3	ELECTRICAL PLANS (PRIVATE LIGHTING WITHIN RW)
SHEET NO. E0-01, E0-01	LANDSCAPING PLANS
SHEET NO. L1-L2	PAVEMENT MARKING PLANS
SHEET NO. PMI-PM2	

PROJECT LOCATION

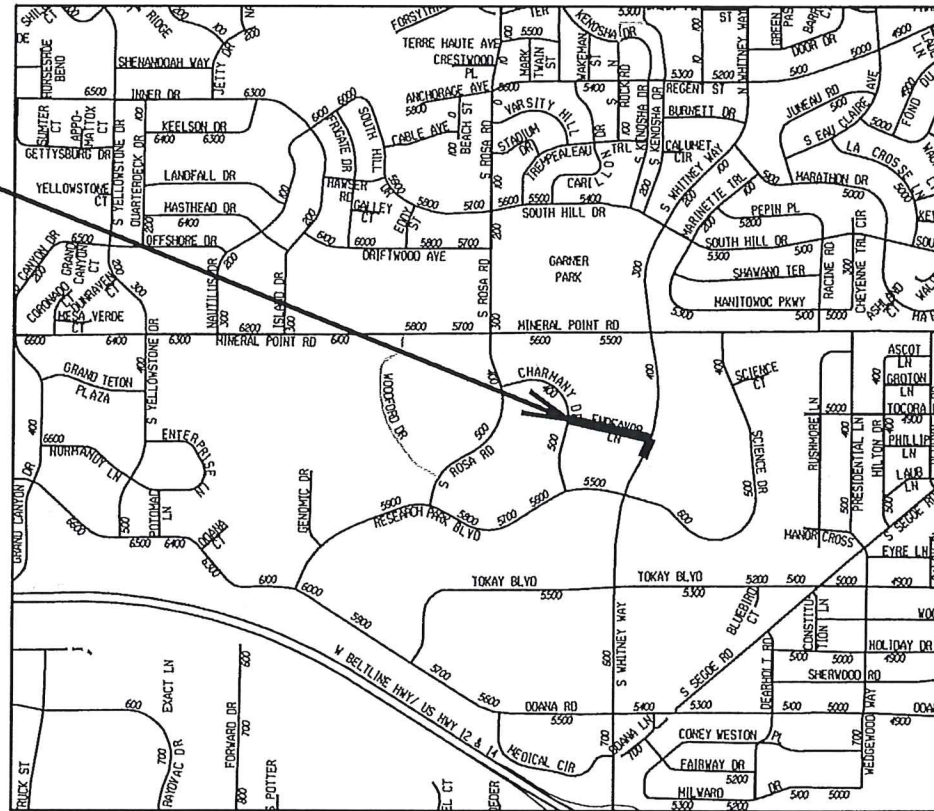
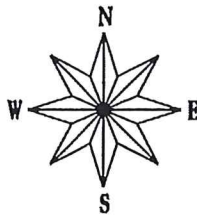

PAVEMENT MARKING DESIGNED BY:



STREET DESIGNED BY:



LIGHTING DESIGNED BY:

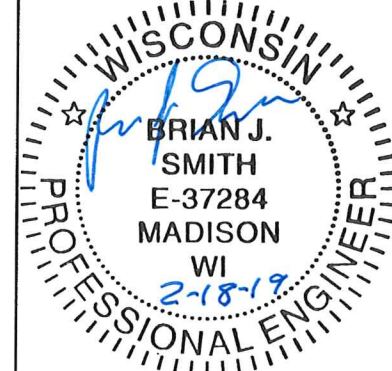

SANITARY SEWER DESIGNED BY:

ADJUST STRUCTURE ONLY
2/18/19 Mark Al

WATER MAIN DESIGNED BY:

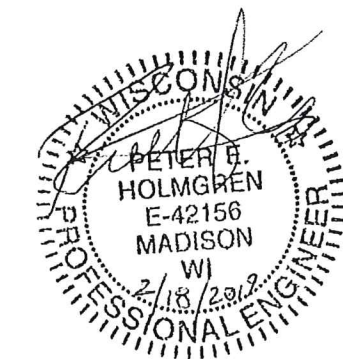

STORM SEWER DESIGNED BY:

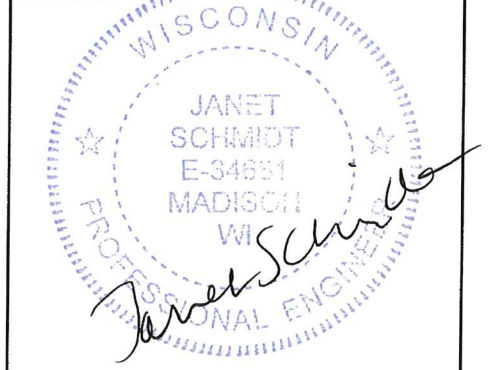

CONVENTIONAL SIGNS

FIELD VERIFY ALL UTILITY LOCATIONS

GAS	— G —
STORM SEWER	— ST —
SANITARY SEWER	— SAN —
WATER	— W —
OVERHEAD ELECTRIC	— OH —
POWER POLE	□

NOTES:

ALL GUTTERS SHALL DRAIN WITH A MINIMUM GRADE OF 0.50% TOWARD STORM SEWER INLETS.

SIDEWALK RAMPS AND CURB THRU SIDEWALK RAMPS SHALL HAVE A MAXIMUM SLOPE OF 1" PER 12". SIDEWALK AND CURB RAMPS SHALL BE CONSTRUCTED WITH A SIDE SLOPE OF 2.00%. SIDEWALK SHALL HAVE A MINIMUM LONGITUDINAL SLOPE OF 0.50% AND A MAXIMUM LONGITUDINAL SLOPE OF 5.00%

PLOT SCALE: PLOT NAME: REV. DATE: ORIGINATOR: CITY OF MADISON, STREETS DIVISION

EXISTING STREET TREES SHALL BE PROTECTED. CONTRACTOR SHALL INSTALL TREE PROTECTION FENCING IN THE AREA BETWEEN THE CURB AND SIDEWALK AND EXTEND IT AT LEAST 5 FEET FROM BOTH SIDES OF THE TREE ALONG THE LENGTH OF THE TERRACE. NO EXCAVATION IS PERMITTED WITHIN 5 FEET OF THE OUTSIDE EDGE OF A TREE TRUNK. IF EXCAVATION WITHIN 5 FEET OF ANY TREE IS NECESSARY, CONTRACTOR SHALL CONTACT CITY FORESTRY (266-4816) 48 HOURS PRIOR TO EXCAVATION TO ASSESS THE IMPACT TO THE TREE AND ROOT SYSTEM. TREE PRUNING SHALL BE COORDINATED WITH CITY FORESTRY PRIOR TO THE START OF CONSTRUCTION. TREE PROTECTION SPECIFICATIONS CAN BE FOUND IN SECTION 107.13 OF CITY OF MADISON STANDARD SPECIFICATIONS FOR PUBLIC WORKS CONSTRUCTION
-[HTTP://WWW.CITYOFMADISON.COM/BUSINESSPW/DOCUMENTS/STDSPESCS2013/PART1.PDF](http://www.cityofmadison.com/business/pwd/documents/stdspecs2013/part1.pdf)

CONTRACTOR SHALL CONTACT CITY FORESTRY BRAD HOFMANN BHOFMANN@CITYOFMADISON.COM OR 266-4816 AT LEAST ONE WEEK PRIOR TO PLANTING TO SCHEDULE INSPECTING THE NURSERY STOCK AND REVIEW PLANTING SPECIFICATIONS WITH THE LANDSCAPER.

ANY TREE REMOVALS THAT ARE REQUIRED FOR CONSTRUCTION WILL REQUIRE AT LEAST A 72 HOUR WAIT PERIOD BEFORE A TREE REMOVAL PERMIT CAN BE ISSUED BY FORESTRY, TO NOTIFY THE ALDER OF THE CHANGE IN THE TREE PLAN.

CONTRACTOR/DEVELOPER SHALL SUBMIT A TRAFFIC CONTROL PLAN TO CITY TRAFFIC ENGINEERING AT LEAST 10 WORKING DAYS PRIOR TO THE START OF WORK. WORK WITHIN THE RIGHT-OF-WAY SHALL NOT BEGIN UNTIL THE TRAFFIC CONTROL PLAN IS APPROVED.

ANY PAVEMENT MARKINGS THAT ARE REMOVED OR DAMAGED SHALL BE REPLACED BY THE DEVELOPER/CONTRACTOR AS DIRECTED BY CITY TRAFFIC ENGINEERING.

ALL PAVEMENT WITHIN THE ENDEAVOR LANE RIGHT-OF-WAY SHALL CONSIST OF:
1 3/4" BITUMINOUS UPPER LAYER, 4 LT 58-28 S
1 3/4" BITUMINOUS LOWER LAYER, 4 LT 58-28 S

ALL EXISTING PAVEMENT (TRAVEL LANES) DISTURBED WITHIN THE WHITNEY WAY RIGHT-OF-WAY SHALL CONSIST OF:
2" BITUMINOUS UPPER LAYER, 4 MT 58-28 S
3 1/2" BITUMINOUS LOWER LAYER, 3 MT 58-28 S

THE PROPOSED LEFT TURN LANE ALONG THE WHITNEY WAY RIGHT-OF-WAY SHALL CONSIST OF:
2" BITUMINOUS UPPER LAYER, 4 MT 58-28 S
3 1/2" BITUMINOUS LOWER LAYER, 3 MT 58-28 S

ALL GUTTERS SHALL DRAIN WITH A MINIMUM GRADES OF 0.5% TOWARD STORM SEWER INLETS.

THE CROSS SLOPE OF SIDEWALKS AND BARRIER FREE SIDEWALK CURB RAMPS SHALL BE 1.5%. THE LONGITUDINAL GRADE OF BARRIER FREE SIDEWALK CURB RAMPS SHALL NOT EXCEED 8.33%. ALL SIDEWALK RAMPS SHALL BE CONSTRUCTED ACCORDING TO S.D.D. 3.03. AT ALL OTHER LOCATIONS THE LONGITUDINAL GRADE OF SIDEWALKS SHALL NOT EXCEED 5.0 % OR THE ADJACENT STREET GRADE WHICHEVER IS GREATER NOR BE LESS THAN 0.4% AND SHALL DRAIN TOWARD STORM SEWER INLETS. SIDE SLOPES WITHIN TEN FEET OF A PUBLIC SIDEWALK SHALL NOT EXCEED 4.00:1. ALL SIDEWALK AND SIDEWALK RAMP ELEVATIONS AND GRADES SHALL BE FIELD VERIFIED AND SET TO COMPLY WITH THE CITY OF MADISON STANDARD SPECIFICATIONS AND THE A.D.A. GUIDELINES.

POWER POLES AND OTHER OBSTRUCTIONS SHALL BE MOVED TO PROVIDE 2 FEET MINIMUM OF CLEAR DISTANCE FROM ANY FACE OF CURB OR EDGE OF SIDEWALK.

THERE MAY BE EXISTING UTILITIES OR OTHER FEATURES WHICH ARE EITHER NOT SHOWN OR SHOWN INCORRECTLY ON THIS PLAN. IT IS THE RESPONSIBILITY OF THE DEVELOPER TO LOCATE AND IDENTIFY ALL UTILITIES AND TOPOGRAPHY WHICH MAY AFFECT THE CONSTRUCTION OF THESE IMPROVEMENTS.

ALL PERMANENT SIGNING AND POSTING WILL BE DETERMINED AND PROVIDED BY THE TRAFFIC ENGINEERING DIVISION, FOLLOWING CONSTRUCTION OF THESE IMPROVEMENTS.

THE DEVELOPER SHALL PROVIDE, INSTALL AND MAINTAIN ALL STREET END BARRICADES, SIGNING AND TRAFFIC CONTROL, AS REQUIRED BY THE CITY TRAFFIC ENGINEER.

PAVEMENT SAWCUTS SHALL BE AS DIRECTED BY THE CITY CONSTRUCTION ENGINEER. SAWCUTS SHOWN ON THE PLAN ARE APPROXIMATE.

DAMAGE TO ANY EXISTING CURB, PAVEMENT, SIDEWALK, ETC. THAT IS TO REMAIN SHALL BE REPAIRED BY THE DEVELOPER/CONTRACTOR AS DIRECTED BY THE ENGINEER.

DEVELOPER/CONTRACTOR SHALL COORDINATE WITH ALL UTILITY COMPANIES TO ADJUST STRUCTURES, MANHOLES, HANDHOLES, ETC. AS NEEDED TO MATCH THE GRADE OF THE NEW PAVEMENT.

ANY WORK SHOWN ON THIS PLAN THAT IS OUTSIDE OF THE RIGHT-OF-WAY OR BEYOND THE LIMITS OF THIS PROJECT SHALL BE CONSIDERED APPROXIMATE AND NOT FOR CONSTRUCTION.

7" STAMPED & COLORED CONCRETE SPECIAL PROVISION

DESCRIPTION

THIS WORK SHALL BE IN ACCORDANCE WITH THE REQUIREMENTS OF PART 3 OF THE STANDARD SPECIFICATIONS, EXCEPT AS HEREIN AFTER AMENDED.

A SEPARATE DESIGN MIX SHALL BE PROVIDED FOR ALL AREAS TO RECEIVE INTEGRALLY COLORED CONCRETE. INTEGRALLY COLORED CONCRETE MIX(ES) SHALL NOT CONTAIN FLY ASH. CONSIDER ADMIXTURE RECOMMENDATIONS FOR CONCRETE MIX DESIGN, HOWEVER, MIX DESIGN MUST ALSO CONFORM TO THE STANDARD SPECIFICATIONS. SUBMIT THE CONCRETE MIX DESIGN TO THE CITY OF MADISON FOR REVIEW.

CONTRACTOR SHALL PROVIDE A 12*XI2*SAMPLE OF THE COLORED CONCRETE, WHICH WILL BE REVIEWED AND APPROVED BY THE CITY PRIOR TO FINAL INSTALLATION. PROVIDE A MINIMUM OF 3 DAYS NOTICE TO THE ENGINEER IN ORDER TO SCHEDULE REVIEW OF THE SAMPLE.

EXCESS CONCRETE MATERIAL FROM MOCKUPS CAN BE USED ELSEWHERE PER THE ENGINEERS APPROVAL IF THE MIX DESIGN MEETS THE STANDARD REQUIREMENTS OF THE SECONDARY USE.

MATERIALS

INTEGRAL-MIX COLORED ADMIXTURE SHALL CONFORM TO THE REQUIREMENTS OF ACI 303.1, ASTM C979, ASTM C494 AND ASSHTO M194. ADMIXTURE SHALL BE A SINGLE-COMPONENT, COLORED, WATER-REDUCING, SET-CONTROLLING ADMIXTURE CONTAINING NO CALCIUM CHLORIDE WITH COLORING AGENTS THAT ARE LIME-PROOF AND ULTRA-VIOLET RESISTANT. THE ADMIXTURE SHALL BE FACTORY FORMULATED AND PACKAGED IN CUBIC YARD DOSAGE INCREMENTS, NOT MULTIPLE ADDITIVES AND PIGMENTS ADDED SEPARATELY INTO THE MIX.

THE COLOR SHALL EITHER BE BASF NATURAL BARK (MC5002) OR AN APPROVED EQUAL.

ALL SURFACES SHALL BE CURED UNIFORMLY. THE CONCRETE SHALL NEVER BE COVERED WITH PLASTIC SHEETING.

CURING COMPOUND SHALL COMPLY WITH ASTM C309 AND BE OF SAME MANUFACTURER AS COLORED ADMIXTURE, FOR USE WITH INTEGRALLY COLORED CONCRETE. ALL PLACING, FINISHING, CURING, JOINT SEALING, AND PATCHING SHALL BE IN ACCORDANCE WITH THE ADMIXTURE MANUFACTURER'S RECOMMENDATIONS.

IMPRINTING PATTERN: USE A 6*X 6*COBBLESTONE PATTERN.

CONSTRUCTION

ADD COLOR PIGMENT TO CONCRETE MIXTURE ACCORDING TO MANUFACTURER'S WRITTEN INSTRUCTIONS AND TO RESULT IN HARDENED CONCRETE COLOR CONSISTENT WITH APPROVED SAMPLES.

PROTECT ALL ADJOINING AREAS OF CONCRETE PRIOR TO POURING COLORED CONCRETE. PERFORM ANY FINISHING WORK AS NECESSARY TO PREPARE THE COLORED CONCRETE FOR STAMPING AS RECOMMENDED BY THE PATTERN MANUFACTURER.

SET STAMP PATTERN IN ACCORDANCE TO THE MANUFACTURER'S SPECIFIED METHODS. CHECK ALL DEPTHS OF IMPRINTS BY TOOL-TO-TOOL SURFACE LEVELING. PERFORM TOOLING AND FINISHING AS STAMPING TOOLS ARE REMOVED AFTER IMPRINTING. ELIMINATE ALL SQUEEZE JOINTS BETWEEN STAMPING TOOLS, IF ANY, WITH HAND TOOLS PRIOR TO CONCRETE SETTING.

JOINT THE CONCRETE IN ACCORDANCE WITH THE STANDARD SPECIFICATIONS AMENDED AS FOLLOWS: SAW JOINTS SUCH THAT THE SAW JOINT FOLLOWS THE CONCRETE RECESS.

APPLY CURING COMPOUND PER MANUFACTURER'S RECOMMENDED COVERAGE RATE AND TO MEET CURING REQUIREMENTS OF THE CITY OF MADISON STANDARD SPECIFICATIONS.

7* STAMPED & COLORED CONCRETE SHALL MATCH THE VISUAL APPEARANCE OF THE APPROVED REFERENCE SAMPLES.

PLOT SCALE: _____

PLOT NAME: _____

REV. DATE: _____

ORIGINATOR: CITY OF MADISON, STREETS DIVISION

REVISION 6/20/19 AJZ
- Whitney Way typical

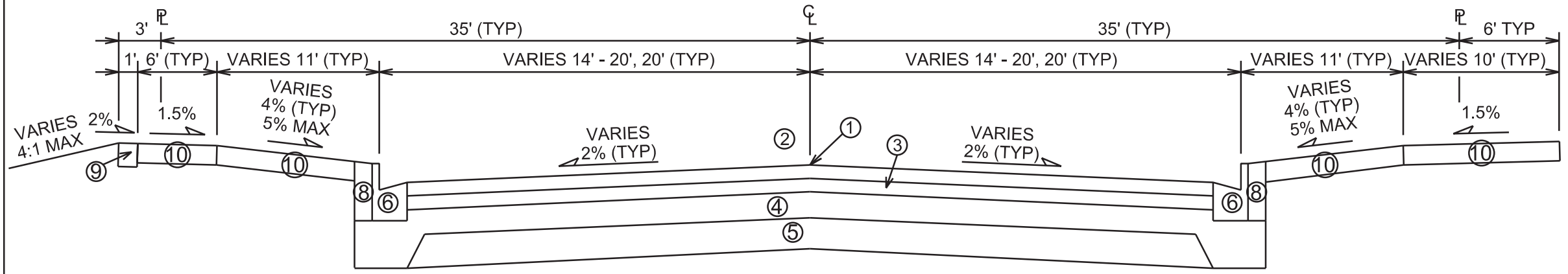

TYPICAL FINISHED SECTION
ENDEAVOR LANE
STA 10+49 TO STA 14+68
STA 15+01 TO STA 15+48

- ① POINT REFERRED TO ON PROFILE
- ② 1 3/4" HMA UPPER LAYER, 4 LT 58-28 S
- ③ 1 3/4" HMA LOWER LAYER, 4 LT 58-28 S
- ④ 6" GRADATION 2 CRUSHED STONE
- ⑤ 6" GRADATION 1 CRUSHED STONE
- ⑥ TYPE 'A' CONCRETE CURB & GUTTER
- ⑦ TYPE 'G' CONCRETE CURB & GUTTER
- ⑧ FILL, INCIDENTAL
- ⑨ 6" TOPSOIL, TERRACE SEED & EROSION MAT
- ⑩ 5" CONCRETE SIDEWALK
- ⑪ 7" CONCRETE SIDEWALK
- ⑫ 2" HMA UPPER LAYER, 4 MT 58-28 S
- ⑬ 3 1/2" HMA LOWER LAYER, 3 MT 58-28 S

GENERAL NOTES:
1. SEE PLAN & PROFILES FOR TOP OF CURB ELEVATIONS.
2. TYPICAL SECTIONS NOT TO SCALE.
*5" CONCRETE SIDEWALK STA 14+68 TO STA 15+01 RT & STA 15+48 TO STA 16+02. 6" TOPSOIL, SEED & EMAT STA 16+02 TO STA 18+80

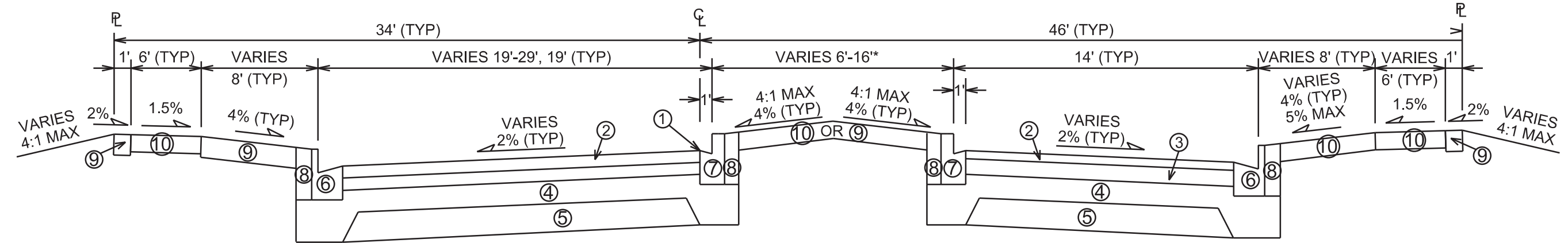

TYPICAL FINISHED SECTION
ENDEAVOR LANE
STA 14+68 TO STA 15+01
STA 15+48 TO STA 18+80

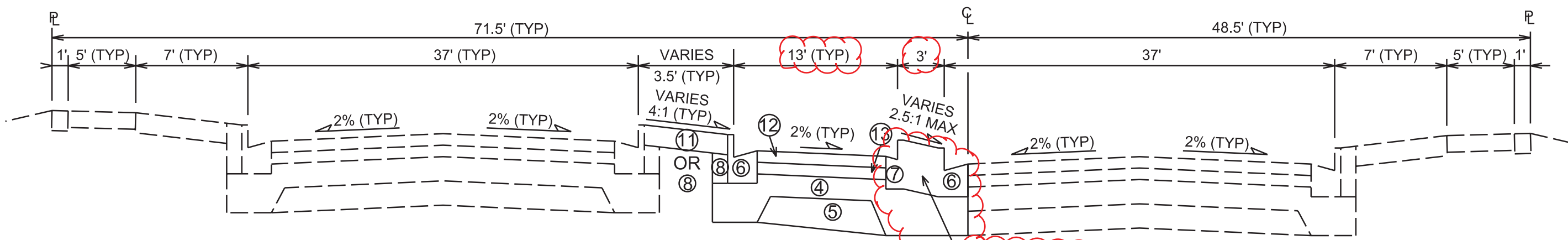

TYPICAL FINISHED SECTION
WHITNEY WAY LEFT TURN LANE
STA 2+81 TO STA 6+50

POUR CURB & GUTTER AND
TERRACE BETWEEN
AS MONOLITHIC

PLOT SCALE: _____
PLOT NAME: _____
REV. DATE: _____
ORIGINATOR: CITY OF MADISON, STREETS DIVISION

SECTION A-A

SECTION B-B

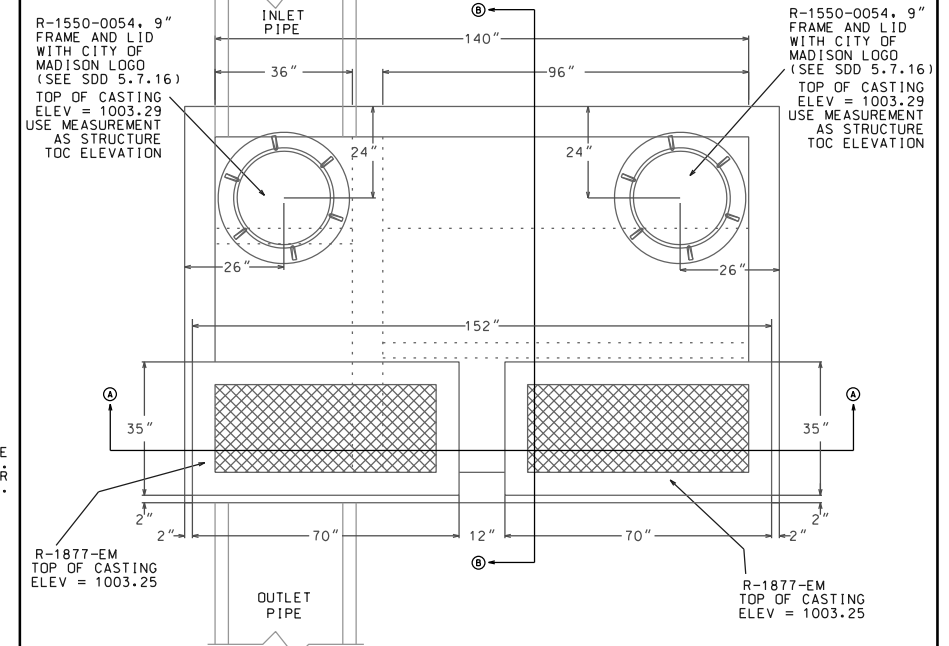
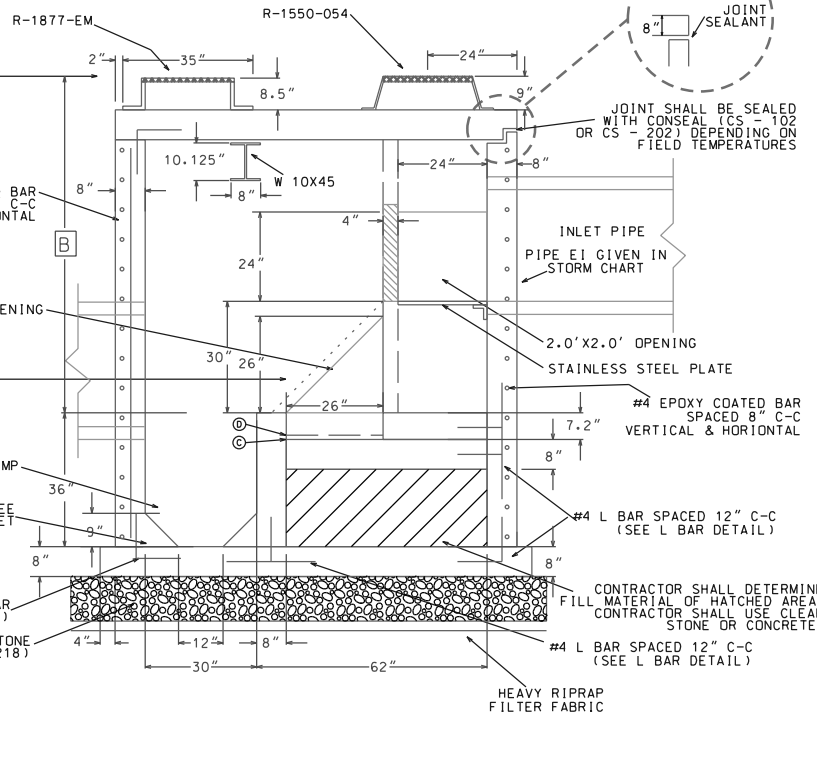
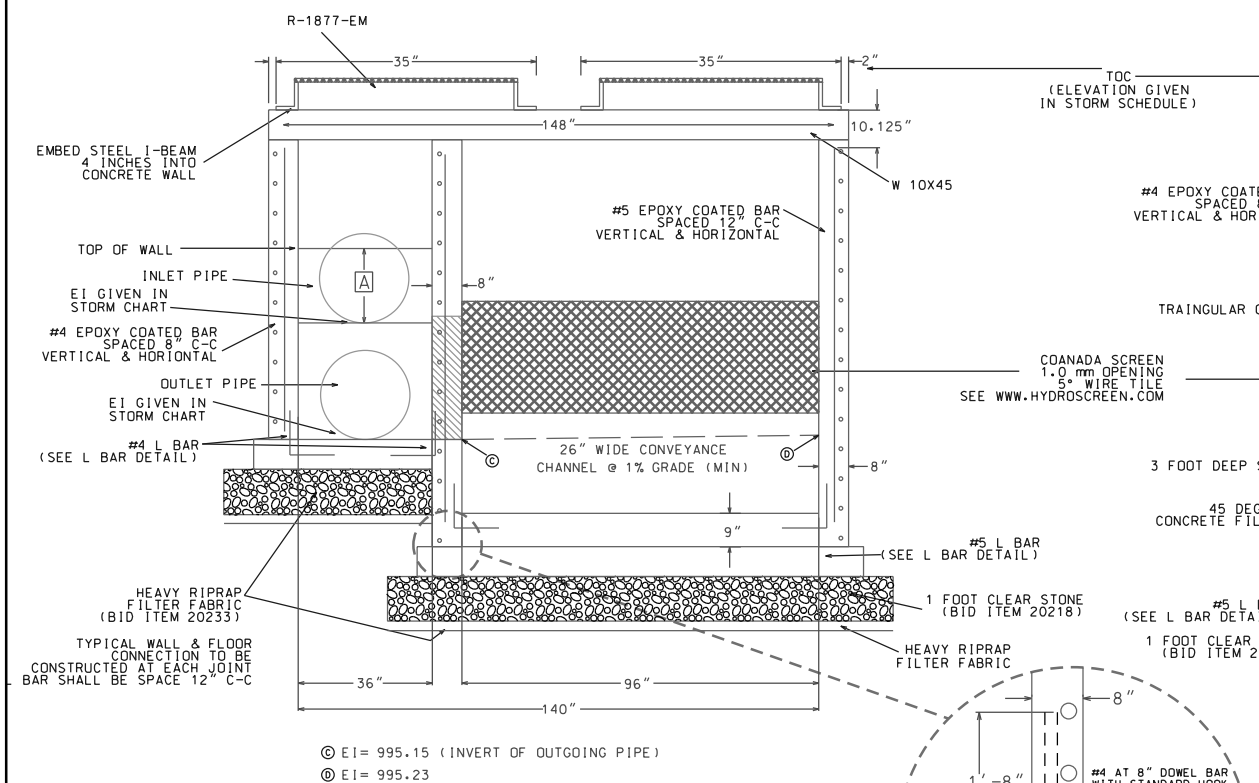

PIPE SIZE	DIMENSION A	DIMENSION B
30"	20"	87" (MIN) 90.48' AS DESIGNED

NE ISOMETRIC VIEW
(SIDEWALLS & ROOF NOT SHOWN)

NW ISOMETRIC VIEW
(SIDEWALLS & ROOF NOT SHOWN)

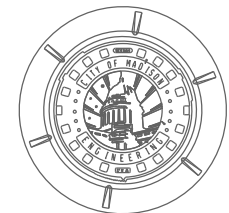
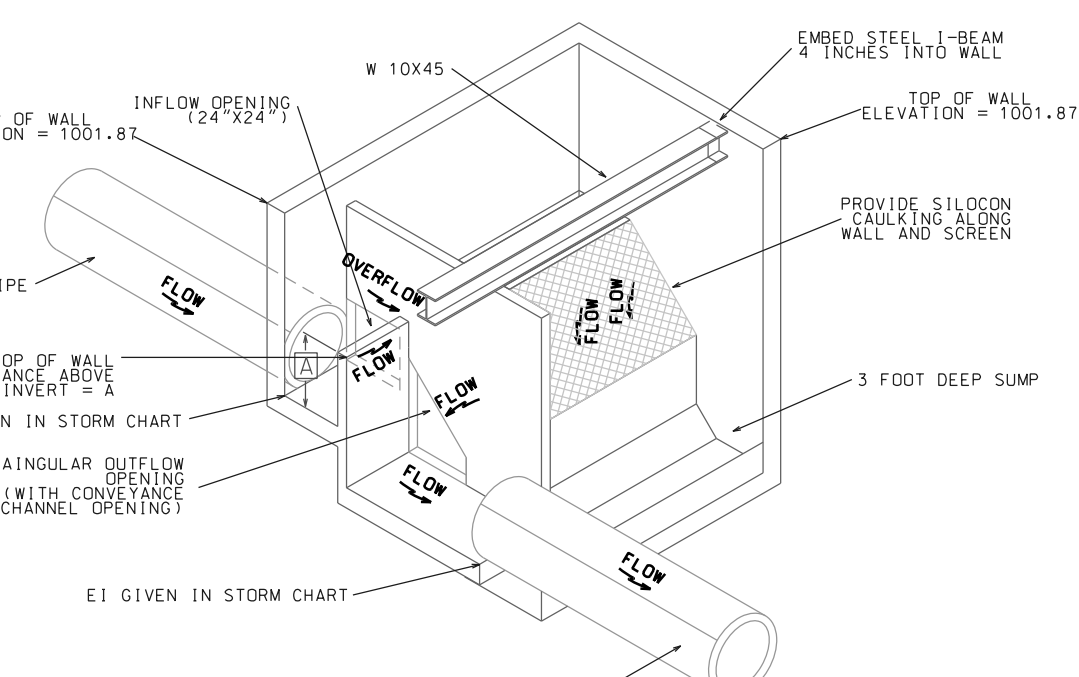
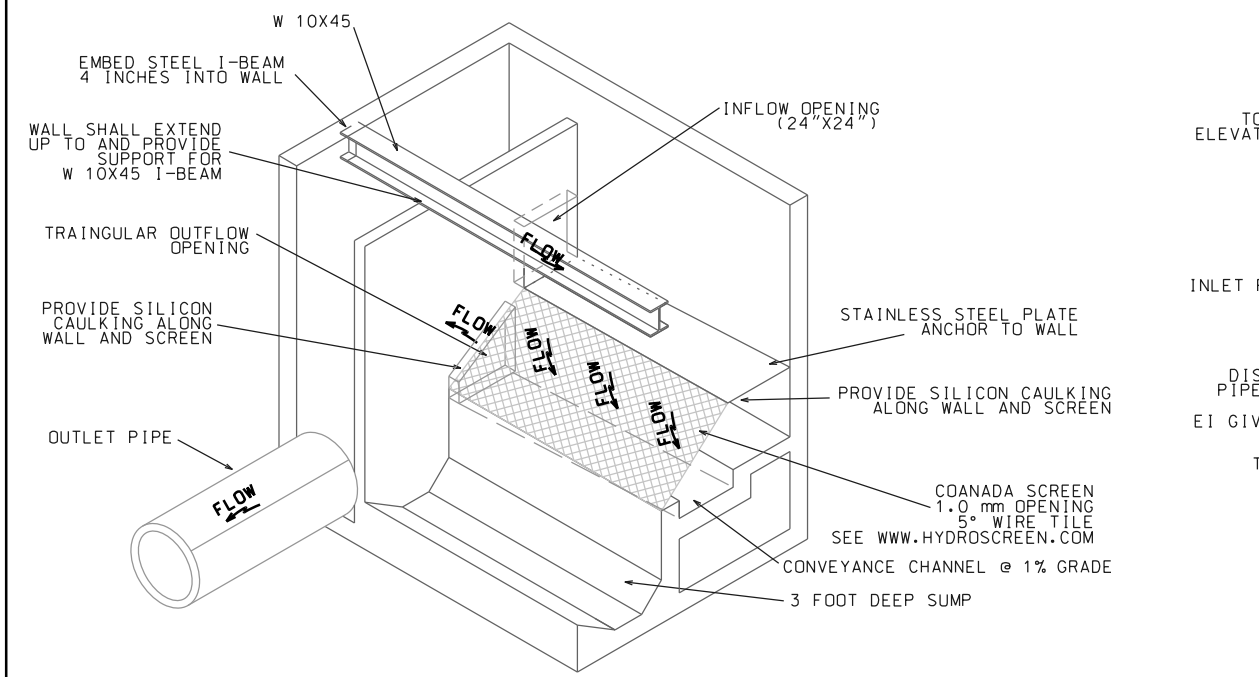

ROOF REINFORCEMENT

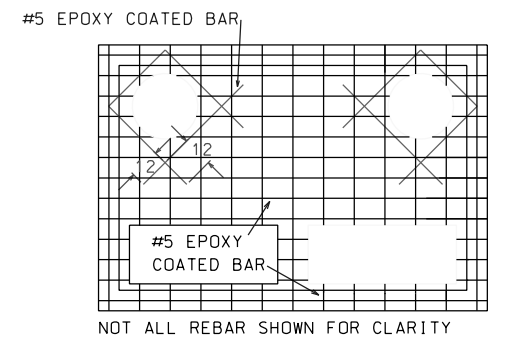

- REBAR REINFORCEMENT NOTES:
1. EPOXY COATED REBARS SHALL BE USED IN ALL CASES
 2. #5 REBARS PLACED 9" ON CENTER EACH WAY WITH 2" CLEAR FROM BOTTOM OF SLAB
 3. ROOF THICKNESS SHALL BE 8" MINIMUM
 4. ALL WALLS ARE 8" THICK
 5. WALL REINFORCEMENT #4 AT 8" ON CENTER EACH WAY
 6. FLOOR REINFORCEMENT #4 AT 12" ON CENTER EACH WAY

PLOT SCALE:

PLOT NAME:

REV. DATE:

ORIGINATOR: CITY OF MADISON, STREETS DIVISION

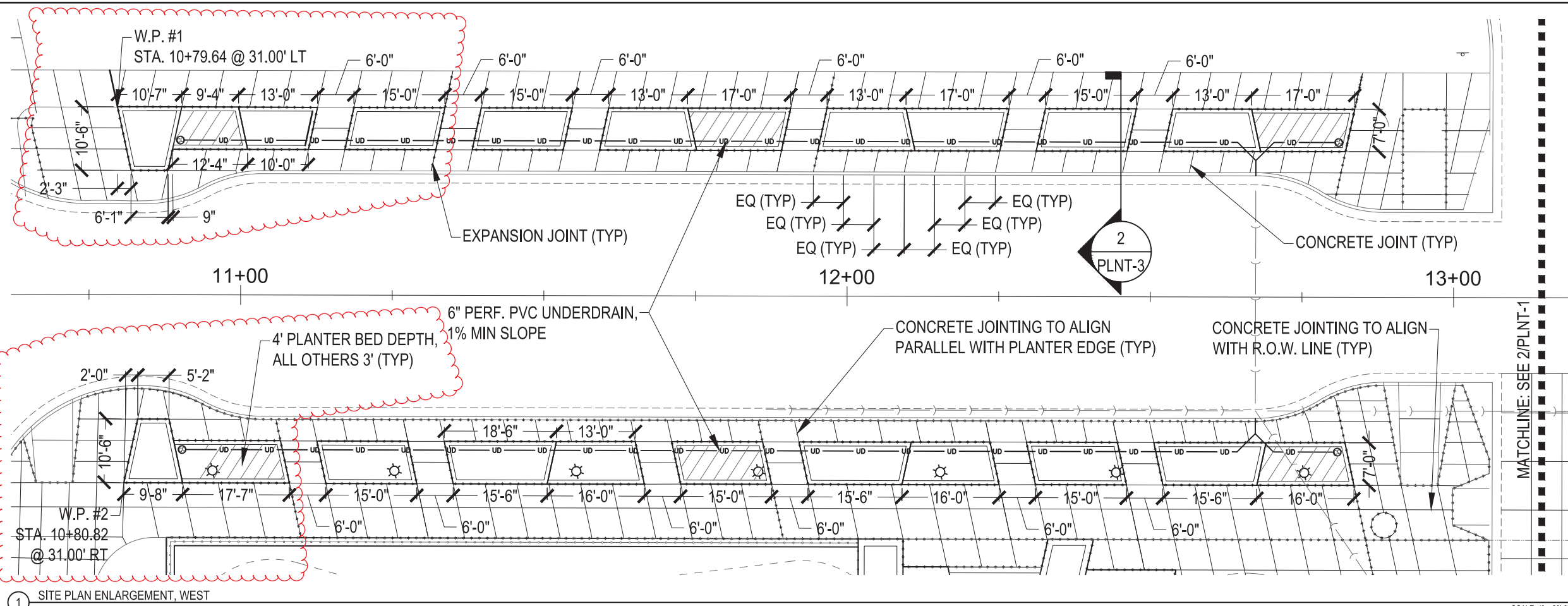
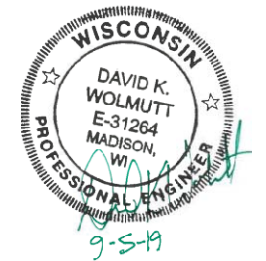

1 SITE PLAN ENLARGEMENT, WEST

SCALE: 1" = 20'-0"

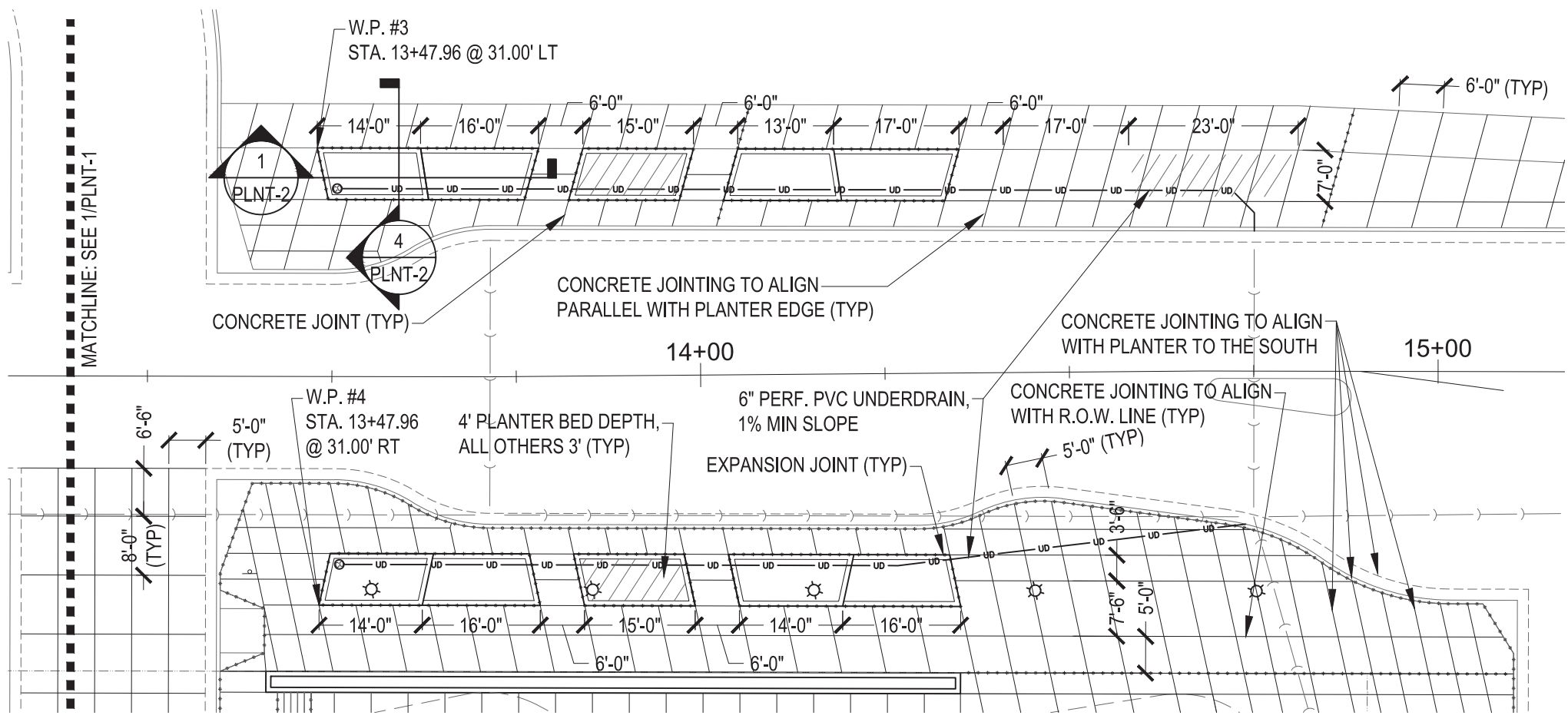

2 SITE PLAN ENLARGEMENT, EAST

NOTES:

1. CONCRETE JOINTING IN PLAZA AND PLANTER AREAS TO BE CONSTRUCTED WITH EQUIDISTANT SPACING.
- REVISION - 5/14/19 SMITHGROUP
- Revised Planter Locations
- Added Concrete Jointing Layout
- REVISION - 9/9/19 SMITHGROUP
- Revised Planter Locations

FILE: \\ymd-file\Projects\10235.000\CAD\C\sheet\ENDEAVOR DR PLANTERS\PLNT-1.2.dwg USER:choraley DATE:Aug. 28 2019 TIME: 11:07 am

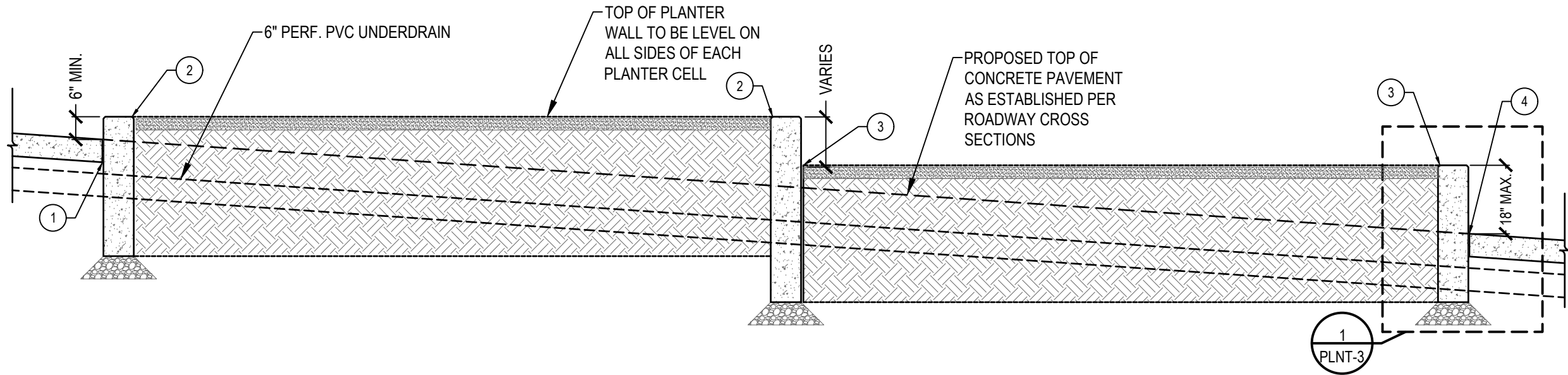

1 TYPICAL PLANTER SECTION

SCALE: 3/4" = 1'-0"

ISSUED FOR	REV	DATE

SEALS AND SIGNATURES

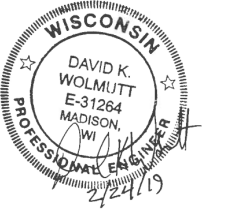

KEY PLAN

DRAWING TITLE
**PLANTER LAYOUT
AND DETAILS**

SCALE
10235.000

PROJECT NUMBER

PLNT-2

DRAWING NUMBER

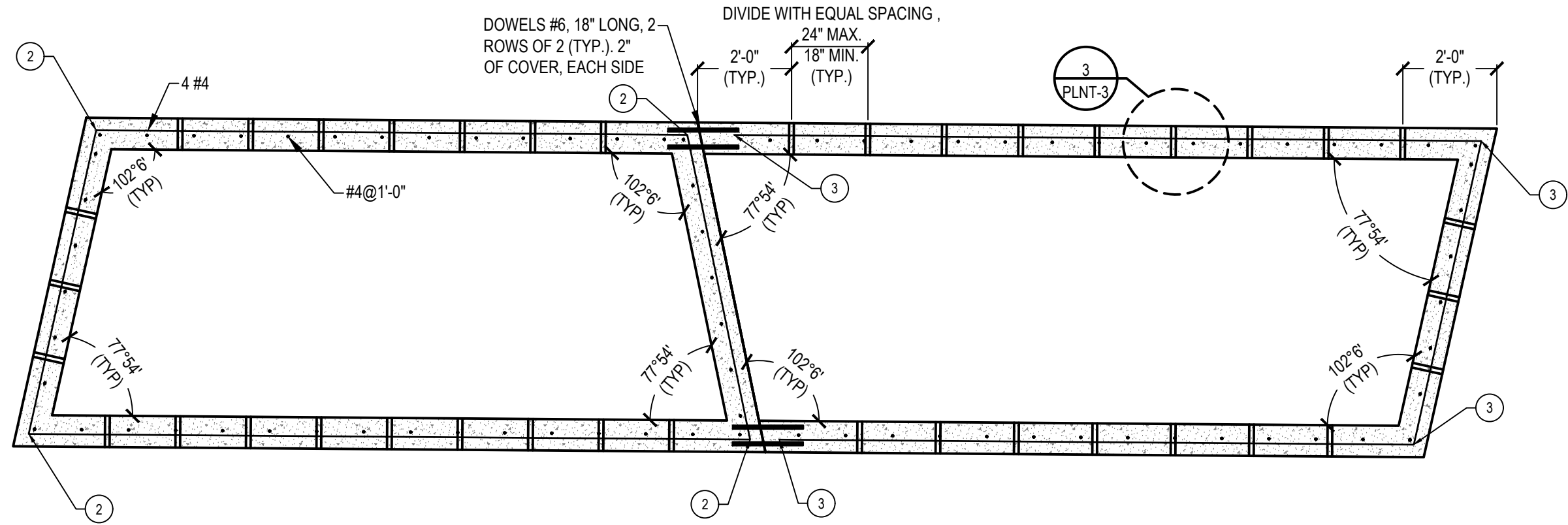

2 TYPICAL PLANTER LAYOUT & REINFORCEMENT PLAN

SCALE: 3/4" = 1'-0"

SMITHGROUP

44 EAST MIFFLIN STREET
SUITE 500
MADISON, WI 53703
608.251.1177
www.smithgroup.com

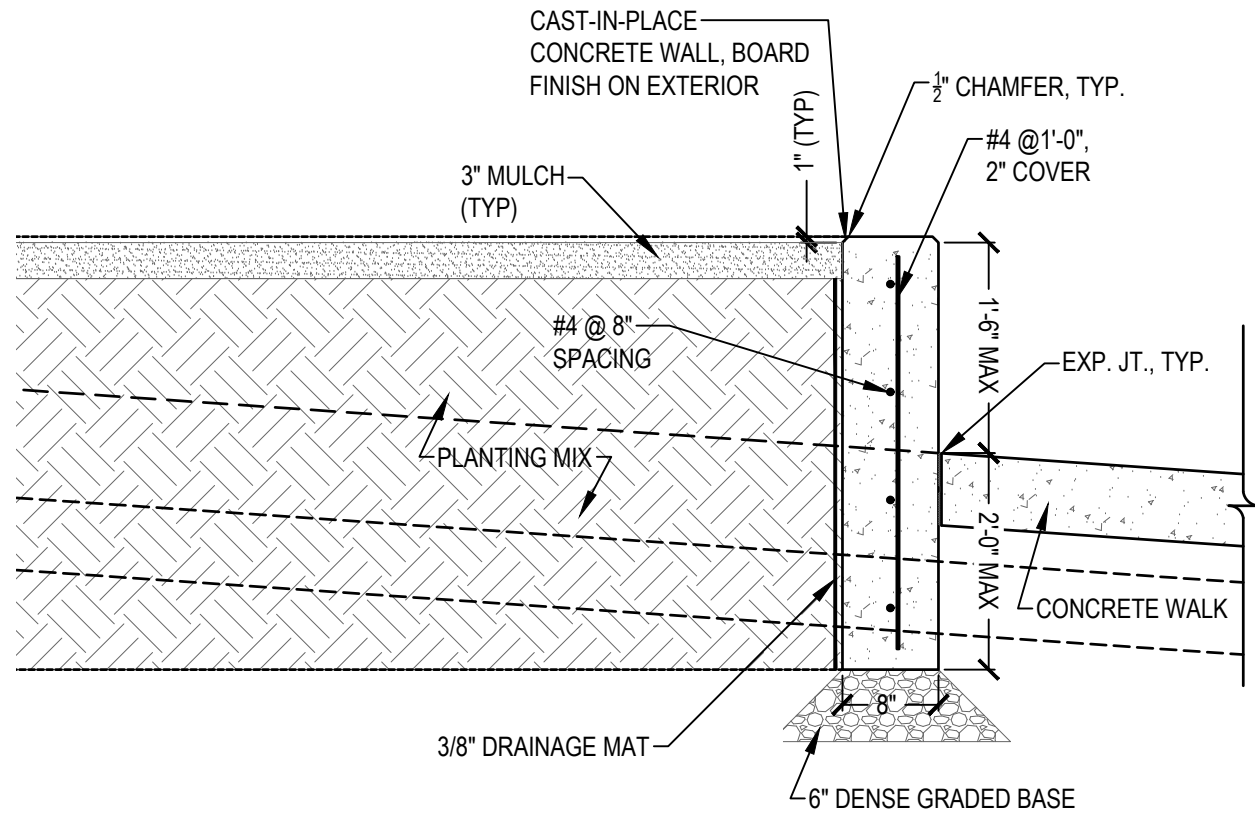

3 RECESSED CHAMFER DETAIL

SCALE: 1'-1/2"

1 TYPICAL PLANTER ENLARGEMENT

SCALE: 1-1/2"=1'-0"

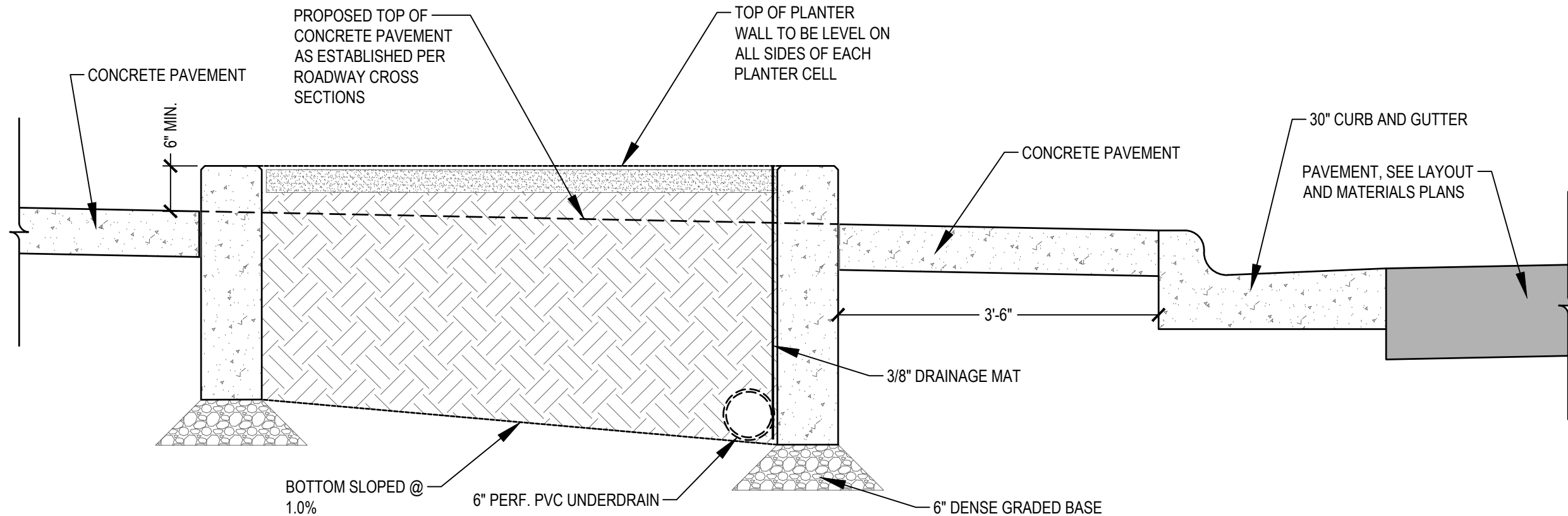

2 TYPICAL PLANTER CROSS SECTION

SCALE: 1-1/2"=1'-0"

ISSUED FOR REV DATE

SEALS AND SIGNATURES



KEY PLAN

DRAWING TITLE
**PLANTER LAYOUT
AND DETAILS**

SCALE 10235.000

PROJECT NUMBER

PLNT-3

DRAWING NUMBER

REVISION 4/19/19 AJZ

- Revised Planter Locations

REVISION 6/20/19 AJZ

- Add note about stamped concrete median

REVISION 10/18/19 AJZ

- Revised Planter Locations

UNIVERSITY RESEARCH PARK/ INNOVATION ONE; PROJECT NO. 11847		SHEET NO. P-1
PLAN AND PROFILE		
ENDEAVOR LANE	CITY OF MADISON	

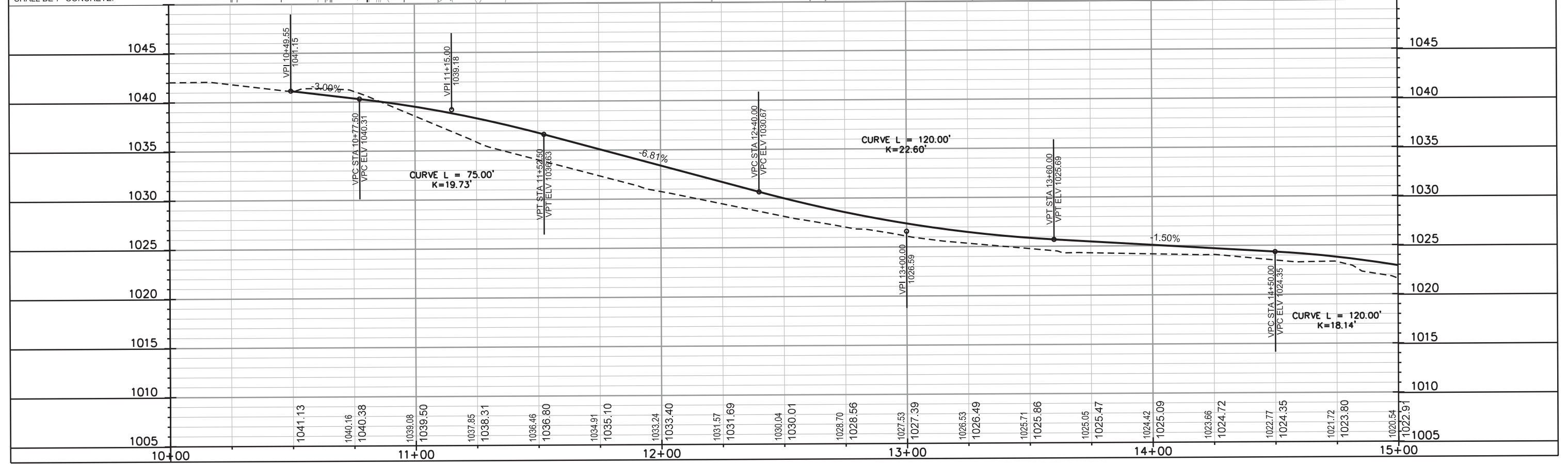
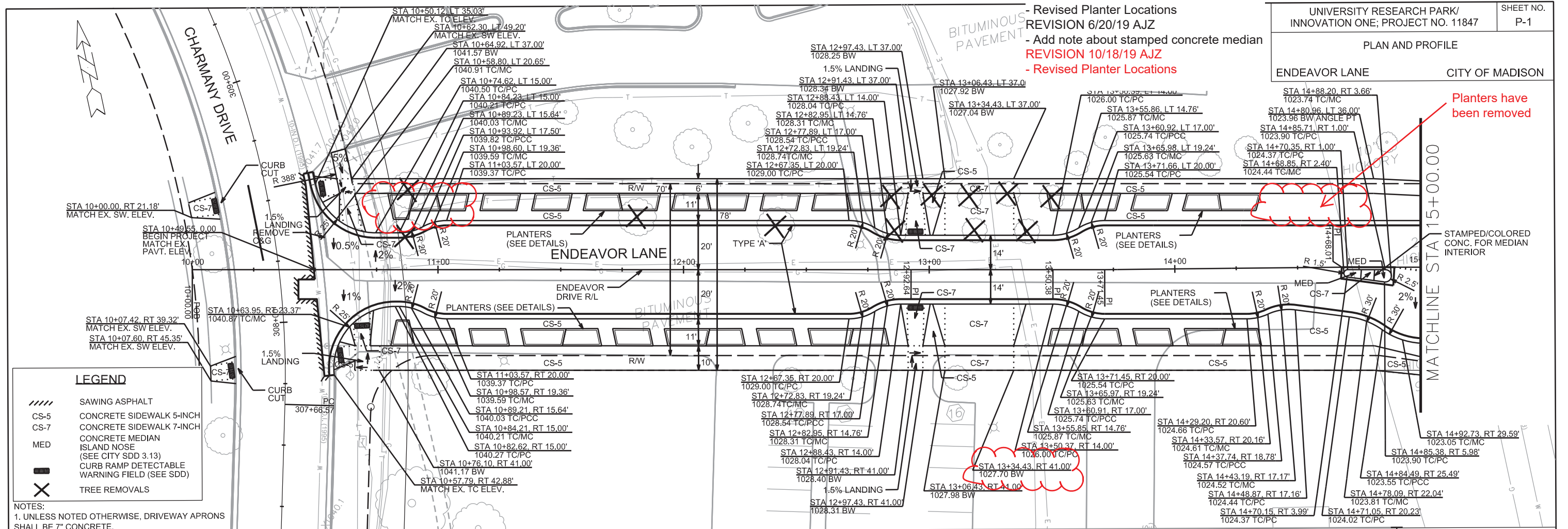

REVISION 6/20/19 AJZ
- Revise Endeavor Lane Median

PLAN AND PROFILE

ENDEAVOR LANE CITY OF MADISON

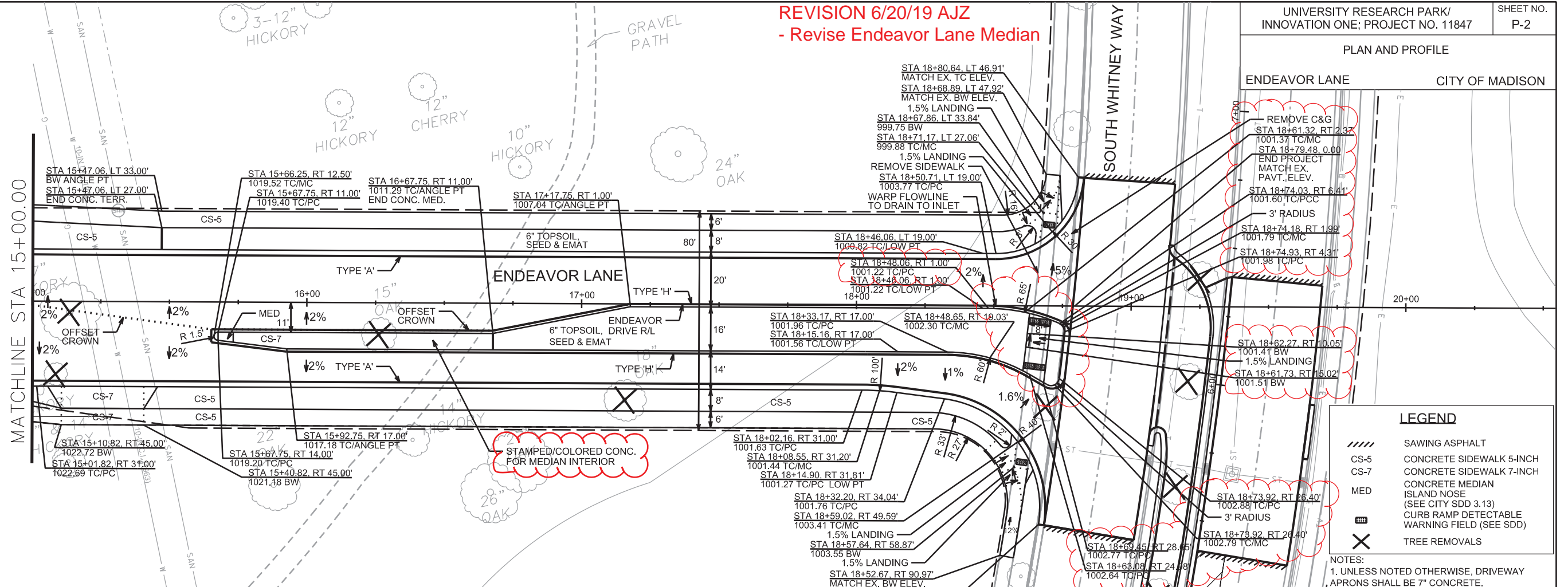

LEGEND

	SAWING ASPHALT
CS-5	CONCRETE SIDEWALK 5-INCH
CS-7	CONCRETE SIDEWALK 7-INCH
MED	CONCRETE MEDIAN ISLAND NOSE (SEE CITY SDD 3.13)
	CURB RAMP DETECTABLE WARNING FIELD (SEE SDD)
	TREE REMOVALS

NOTES:
 1. UNLESS NOTED OTHERWISE, DRIVEWAY APRONS SHALL BE 7" CONCRETE.

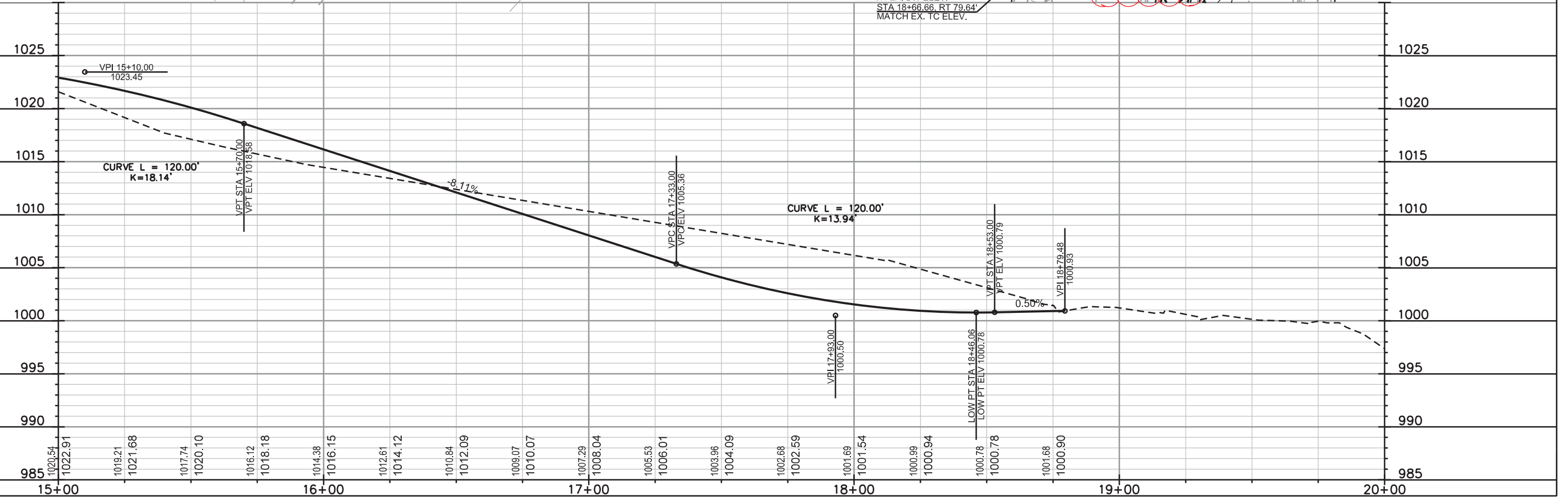

PLOT SCALE: _____
 REV. DATE: _____
 ORIGINATOR: CITY OF MADISON, STREETS DIVISION

REVISION 6/20/19 AJZ
- Turn Lane
REVISION 10/18/19 AJZ
- Clearing & Grubbing for
Vision Corner

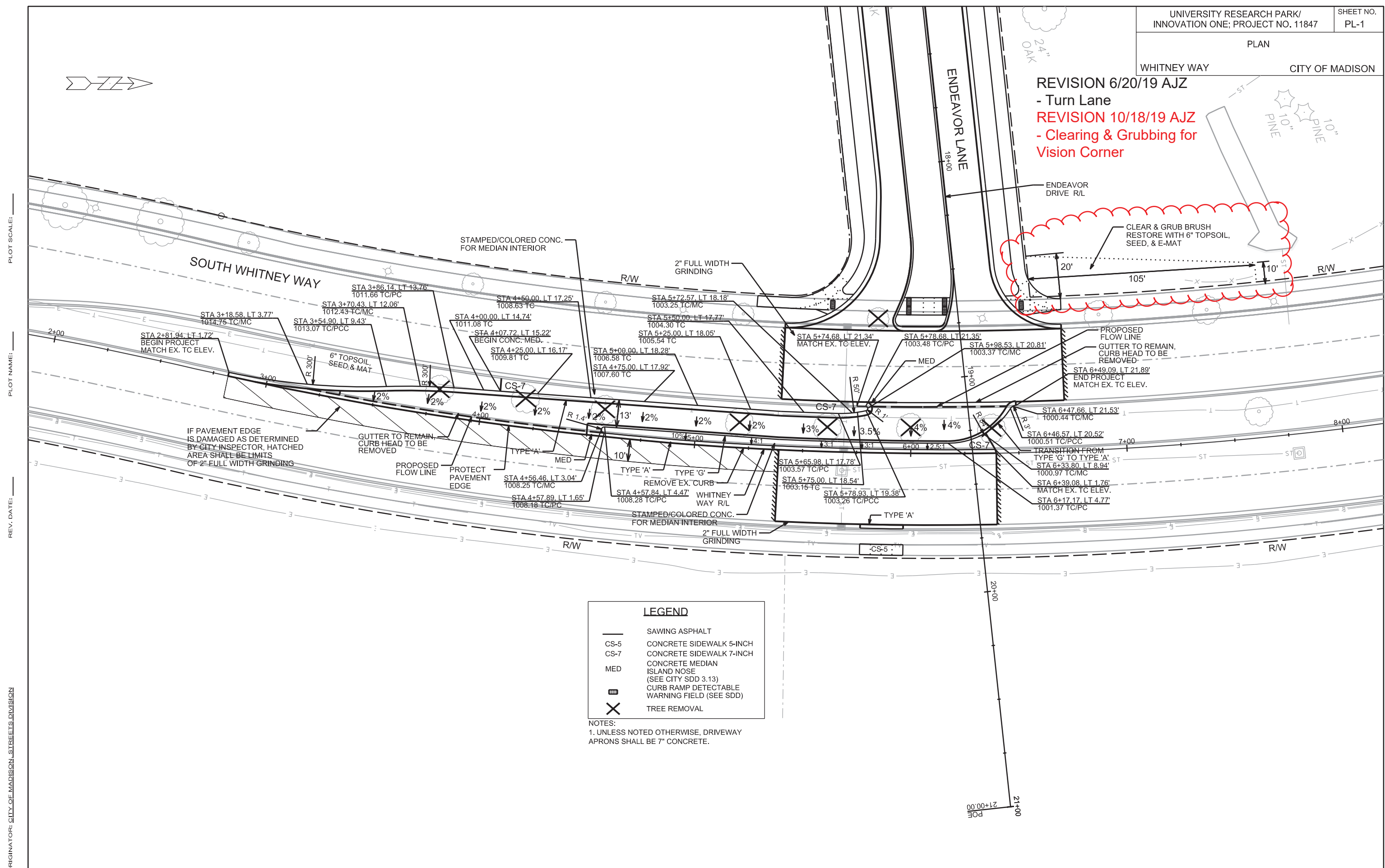

LEGEND

- SAWING ASPHALT
- CS-5 CONCRETE SIDEWALK 5-INCH
- CS-7 CONCRETE SIDEWALK 7-INCH
- MED CONCRETE MEDIAN ISLAND NOSE (SEE CITY SDD 3.13)
- ▨ CURB RAMP DETECTABLE WARNING FIELD (SEE SDD)
- ✕ TREE REMOVAL

NOTES:
1. UNLESS NOTED OTHERWISE, DRIVEWAY APRONS SHALL BE 7" CONCRETE.

PLOT SCALE: _____
PLOT NAME: _____
REV. DATE: _____

ORIGINATOR: CITY OF MADISON, STREETS DIVISION

REVISION 4/5/19 AJZ
- Added Plan Note

UNIVERSITY RESEARCH PARK/ INNOVATION ONE; PROJECT NO. 11847	SHEET NO. PL-2
PLAN	
CHARMANY DRIVE	CITY OF MADISON

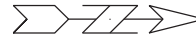

LEGEND

—	SAWING ASPHALT
CS-5	CONCRETE SIDEWALK 5-INCH
CS-7	CONCRETE SIDEWALK 7-INCH
MED	CONCRETE MEDIAN ISLAND NOSE (SEE CITY SDD 3.13)
■	CURB RAMP DETECTABLE WARNING FIELD (SEE SDD)
X	TREE REMOVAL

NOTES:
1. UNLESS NOTED OTHERWISE, DRIVEWAY APRONS SHALL BE 7" CONCRETE.
2. SEE CITY OF MADISON STREET TERRACE PERMITS ENGT-2018-04411 AND ENGT-2019-01049 FOR THE APPROVED LOCATION OF TEMPORARY ACCESS DRIVES TO FACILITATE THE PRIVATE SITE CONSTRUCTION AND RESTORATION REQUIREMENTS WHEN THE TEMPORARY ACCESS DRIVES ARE REMOVED.

PLOT SCALE:

PLOT NAME:

REV. DATE:

ORIGINATOR: CITY OF MADISON, STREETS DIVISION

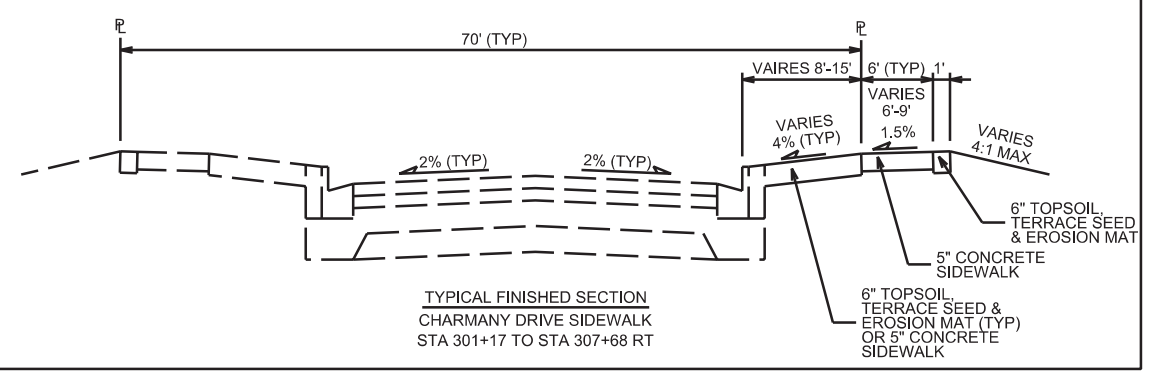
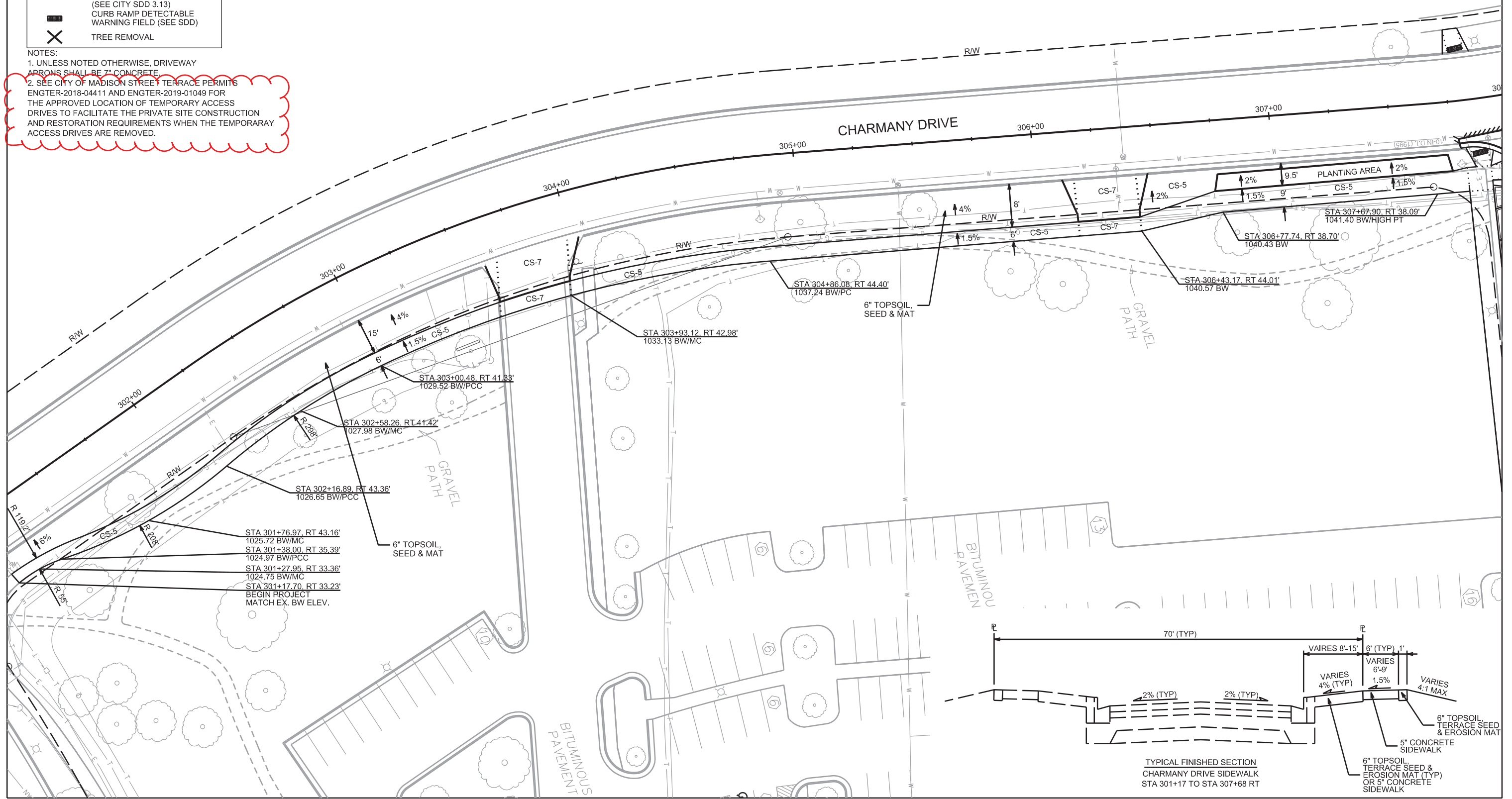

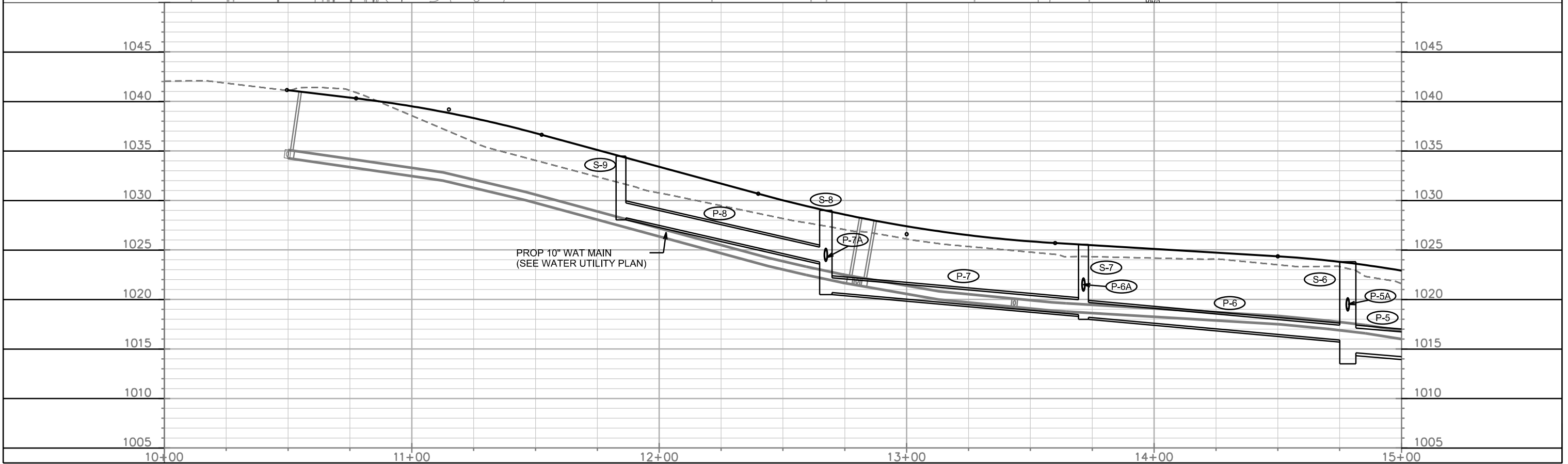
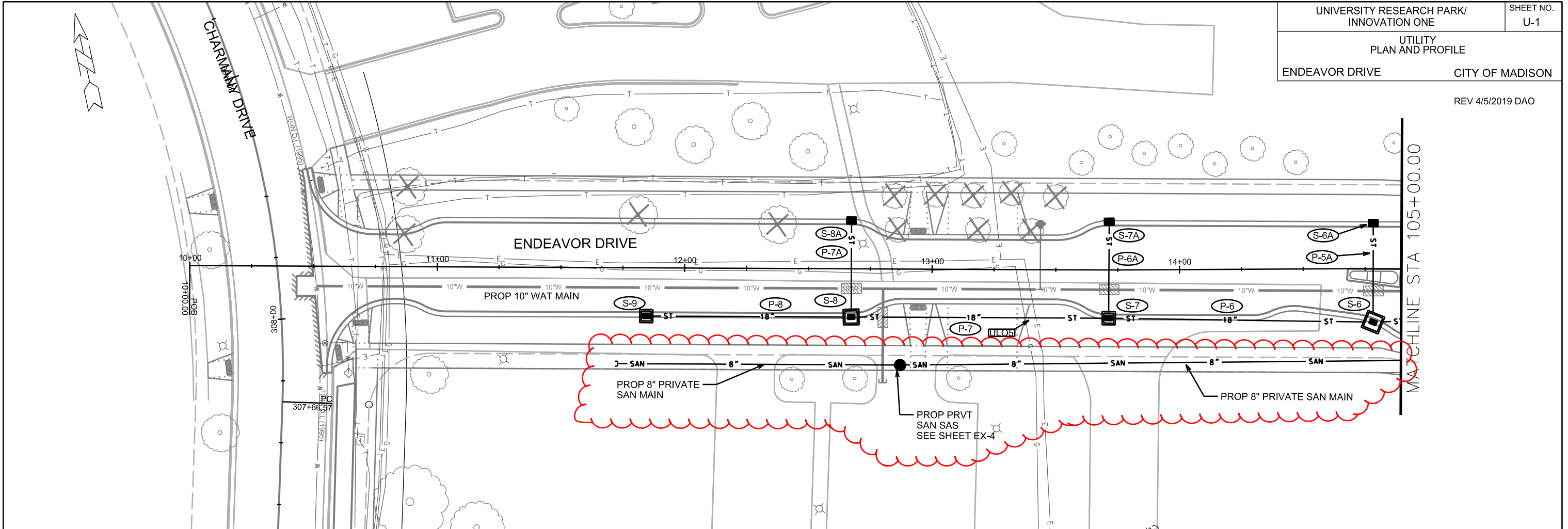

PLOT SCALE: _____
 PLOT NAME: _____
 REV. DATE: _____
 ORIGINATOR: CITY OF MADISON, STREETS DIVISION

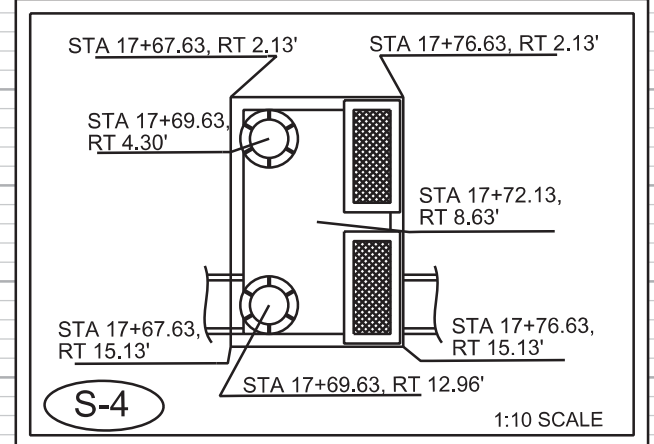
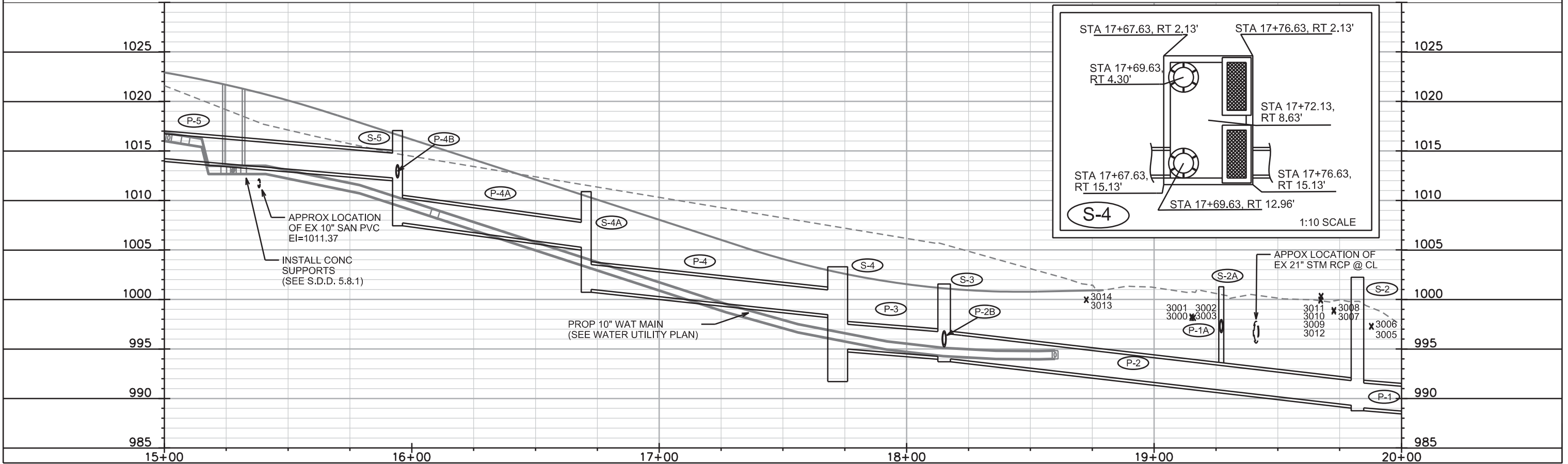
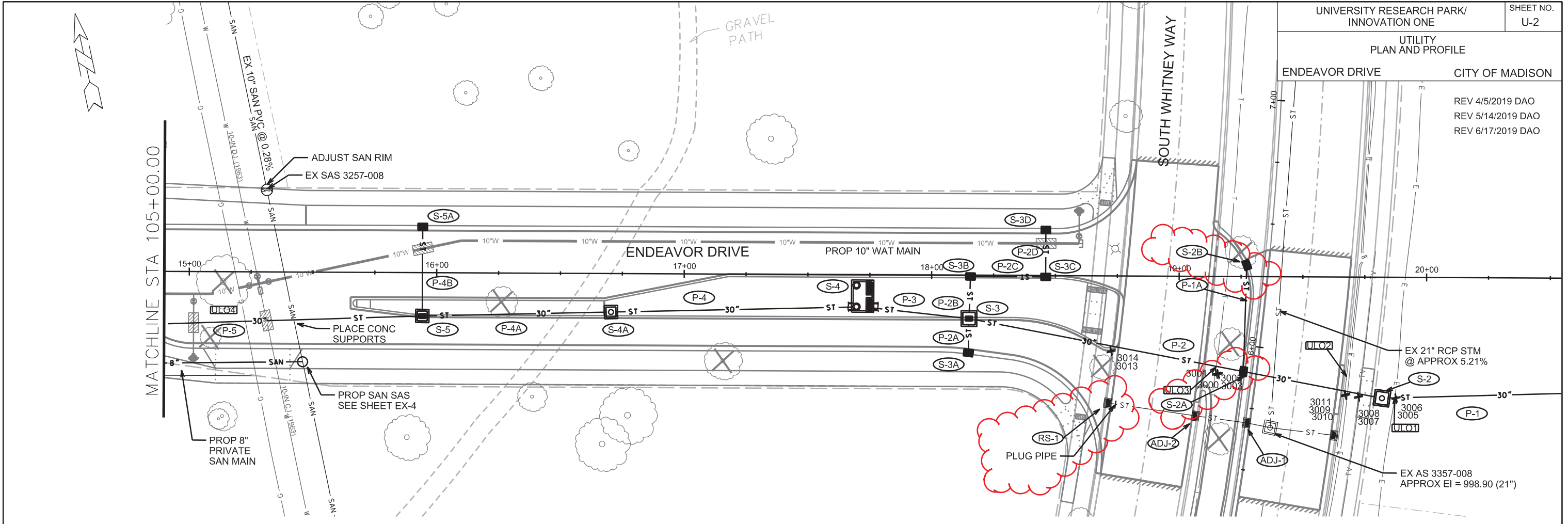

PLOT SCALE: _____

PLOT NAME: _____

REV. DATE: _____

ORIGINATOR: CITY OF MADISON, STREETS DIVISION

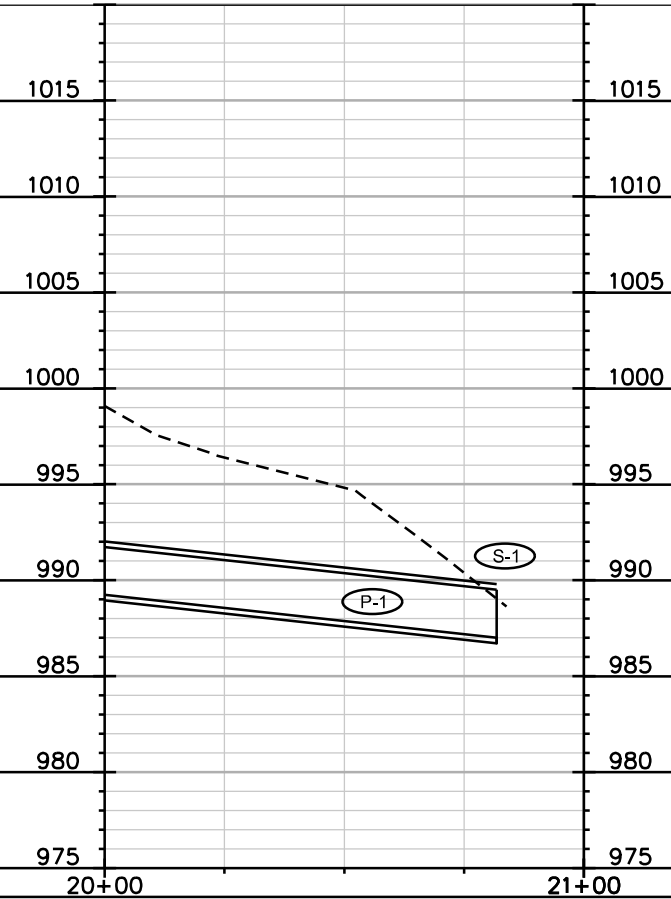
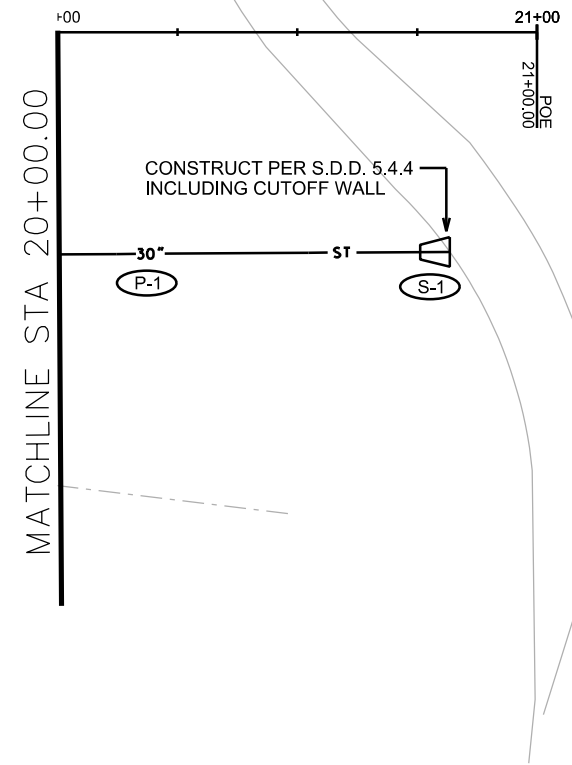

PLOT SCALE: _____

PLOT NAME: _____

REV. DATE: _____

ORIGINATOR: CITY OF MADISON, STREETS DIVISION

STORM SEWER SCHEDULE

* REV 5/14/2019 DAO
 ** REV 6/17/2019 DAO

UNIVERSITY RESEARCH PARK/ INNOVATION ONE	SHEET NO. U-4
STORM SEWER SCHEDULE	
PROJ #11847	CITY OF MADISON

PROPOSED STORM STRUCTURES

STRUC. NO.	STATION	LOCATION (OFFSET)	TYPE	TOP OF CASTING	E.I.	DEPTH	NOTES
ENDEAVOR LN							
S-1	20+81.80	RT-45.79	30" AE W/ GATE	-	987.00	-	
* S-2	19+82.17	RT-48.88	5X5 SAS	1001.38	989.16	12.22	W/1550-0054
** S-2A	19+26.65	RT-38.45	SADDLED H TYPE 2	1001.28	993.60	7.68	W/3067-7004-V; (5)
** S-2B	19+27.76	RT-4.86	H INLET	1000.91	997.41	3.50	W/3067-7004-V; (5)
** S-3	18+15.16	RT-17.00	5X5 SAS	1001.56	994.15	7.41	LP; W/3067-7004-VB; (5)
S-3A	18+14.96	RT-31.32	H INLET	1001.27	996.27	5.00	LP; W/3067-7004-VB
** S-3B	18+15.69	RT-1.00	H INLET	1001.55	996.63	4.92	W/3067-7004-V; (5)
** S-3C	18+46.06	RT-1.00	H INLET	1001.22	997.15	4.07	LP; W/3067-7004-VB; (5)
S-3D	18+46.06	LT-18.50	H INLET	1000.82	997.42	3.40	LP; W/3067-7004-VB
S-4	17+72.13	RT-8.63	SC TR DEVICE	1003.29	995.15	8.14	FP; (1)
S-4A	16+70.47	RT-15.56	4X4 SAS	1010.88	1001.12	9.76	FP; W/1550-0054
** S-5	15+94.25	RT-17.00	4X4 SAS	1017.05	1007.87	9.18	FP; W/3067-7004-V; (5)
S-5A	15+94.25	LT-18.50	H INLET	1016.65	1013.15	3.50	W/3067-7004-V
S-6	14+78.27	RT-21.58	6X6 SAS	1023.81	1013.50	10.31	W/3067-7004-V; (2)
S-6A	14+78.18	LT-18.50	H INLET	1023.75	1020.25	3.50	W/3067-7004-V
S-7	13+71.45	RT-19.50	4X4 SAS	1025.54	1018.29	7.25	W/3067-7004-V
S-7A	13+71.66	LT-19.50	H INLET	1025.54	1022.04	3.50	W/3067-7004-V
S-8	12+67.35	RT-19.50	5X5 SAS	1029.00	1020.80	8.20	W/3067-7004-V; (3)
S-8A	12+67.35	LT-19.50	H INLET	1029.00	1025.50	3.50	W/3067-7004-V
S-9	11+84.54	RT-19.50	4X4 SAS	1034.47	1028.47	6.00	W/3067-7004-V

PROPOSED STORM PIPES

PIPE NO.	FROM (DNSTM)	TO (UPSTM)	DISCH. E.I.	INLET E.I.	PLAN (PAY) LGTH (FT)	PIPE LGTH (FT)	SLOPE (%)	PIPE SIZE	TYPE	NOTES
ENDEAVOR LN										
* P-1	S-1	S-2	987.00	989.16	100	97	2.23%	30"	RCP	
P-1A	S-2A	S-2B	996.81	997.41	43	40	1.49%	12"	RCP	NCM
* P-2	S-2	S-3	989.16	994.15	170	165	3.02%	30"	RCP	
P-2A	S-3	S-3A	995.65	996.27	14	10	6.02%	12"	RCP	
P-2B	S-3	S-3B	995.40	996.63	17	14	9.11%	15"	RCP	
P-2C	S-3B	S-3C	996.88	997.15	29	27	0.99%	12"	RCP	
P-2D	S-3C	S-3D	997.25	997.42	18	17	1.00%	12"	RCP	
P-3	S-3	S-4	994.15	995.15	43	37	2.72%	30"	RCP	
P-4	S-4	S-4A	998.25	1001.12	102	96	2.99%	30"	RCP	
P-4A	S-4A	S-5	1005.13	1007.87	76	72	3.81%	30"	RCP	NCM
P-4B	S-5	S-5A	1012.44	1013.15	36	33	2.15%	12"	RCP	NCM
P-5	S-5	S-6	1012.19	1014.75	116	111	2.31%	30"	RCP	NCM
P-5A	S-6	S-6A	1019.00	1020.25	40	36	3.49%	12"	RCP	NCM
P-6	S-6	S-7	1015.75	1018.29	107	102	2.50%	18"	RCP	
P-6A	S-7	S-7A	1021.00	1022.04	39	36	2.89%	12"	RCP	NCM
P-7	S-7	S-8	1018.39	1020.80	104	100	2.42%	18"	RCP	
P-7A	S-8	S-8A	1024.00	1025.50	39	36	4.23%	12"	RCP	NCM
P-8	S-8	S-9	1023.50	1028.47	83	78	6.35%	18"	RCP	

STORM SEWER ULOs

ULO NO.	STATION	LOCATION (OFFSET)	TYPE	NOTES
SEE 3005, 3006				
* ULO1	19+87.66	RT-46.40	ELEC	SEE 3007,3008, 3009, 3010, 3011
* ULO2	19+68.29	RT-46.30	ELEC/TEL	SEE 3000, 3001, 3002, 3003
* ULO3	19+15.14	RT-36.25	TEL	
ULO4	15+22.76	RT-20.01	GAS	
ULO5	13+39.45	RT-19.50	GAS/ELEC	
* 3000	19+15.19	RT-39.54	FIBER	TOP @ 998.27
* 3001	19+15.29	RT-39.11	FIBER	TOP @ 998.13
* 3002	19+16.05	RT-39.25	FIBER	TOP @ 998.17
* 3003	19+15.97	RT-39.68	FIBER	TOP @ 998.14
* 3005	19+87.82	RT-48.98	POWER	TOP @ 997.32
* 3006	1987+91.00	RT-48.61	POWER	TOP @ 997.24
* 3007	19+72.66	RT-48.59	FIBER	TOP @ 998.79
* 3008	19+72.76	RT-48.11	FIBER	TOP @ 998.92
* 3009	19+67.57	RT-47.38	POWER	TOP @ 1000.27
* 3010	19+67.54	RT-47.85	POWER	TOP @ 1000.35
* 3011	19+67.40	RT-47.33	POWER	TOP @ 999.88
* 3012	19+67.39	RT-47.92	POWER	TOP @ 999.98
* 3013	18+72.59	RT-30.70	POWER	TOP @ 999.97
* 3014	18+72.72	RT-30.16	POWER	TOP @ 999.96

ADJUST/REMOVE STORM STRUCTURES

STRUC. NO.	TYPE	STATION	LOCATION (OFFSET)	TOP OF CASTING	PROP TOC	ADJ (FT)	NOTES
S WHITNEY WAY							
ADJ-1	IN 3357-011	5+68.98	LT-1.26	1002.45	1002.44	-0.01	
ADJ-2	IN 3357-010	5+68.88	LT-21.55	1003.69	1003.03	-0.66	
** ADJ-3	IN 3357-009	5+69.00	LT-58.02	1003.27	1003.30	0.03	(4) TO BE REMOVED (RS-1)
** RS-1	IN 3357-009	5+69.00	LT-58.02				PLUG PIPE

NOTE: PLAN LENGTH (PAY LENGTH) IS FROM CENTER OF STRUCTURE TO CENTER OF STRUCTURE. PIPE LENGTH IS ACTUAL LENGTH OF PIPE FROM STRUCTURE WALL TO STRUCTURE WALL. SLOPE CALCULATED USING PIPE LENGTH.

STANDARD NOTES:

- ABBREVIATIONS: AE = APRON ENDWALL; RCP = REINFORCED CONCRETE PIPE; HERCP = HORIZONTAL ELLIPTICAL REINFORCED CONCRETE PIPE; DNA = DOES NOT APPLY; SAS = SEWER ACCESS STRUCTURE; LP = LOW POINT INLET STRUCTURE; FP = FIELD POURED STRUCTURE; TR = TOP OF CONCRETE ROOF; NCM = NO CROWN MATCH FOR PIPES; UD = UNDERDRAIN
- APPROXIMATE DISCHARGE E.I. GIVEN, ADJUST E.I. AND PIPE SLOPE IN THE FIELD.
- TOP OF CASTING GRADE GIVEN IS THE TOP OF CURB FOR INLET STRUCTURES AND THE FLOWLINE OF THE CLOSED CASTING FOR SAS's.
- TOP OF CONCRETE ROOF (TR) IS 1.25' BELOW TOP OF CASTING UNLESS OTHERWISE NOTED.
- ALL REINFORCED CONCRETE PIPES TO BE CLASS III UNLESS OTHERWISE NOTED.
- SURVEYOR TO CONFIRM THAT ALL INLET STATION / OFFSETS LINE UP WITH PROPOSED CURB AND GUTTER.
- ALL STRUCTURES CALLED OUT AS FIELD POURED SHALL BE FIELD POURED. ALL OTHER STRUCTURES (NOT INDICATED AS FIELD POURED) SHALL BE SUBMITTED TO CITY ENGINEERING FOR APPROVAL IF PRECAST STRUCTURES ARE PREFERRED. CONTACT DANIEL OLIVARES OF CITY ENGINEERING AT (608) 261-9285 FOR PRECAST APPROVALS, FAX SHOP DRAWINGS TO (608)264-9275, OR EMAIL SHOP DRAWINGS TO DAOLIVARES@CITYOFMADISON.COM.

SPECIFIC NOTES

- (1) STA & LOC OF CENTER OF STRUCTURE GIVEN; SEE DETAIL SHEET D-1 SCREEN TREATMENT DEVICE
- (2) PROP PRVT CONNECTION 30" RCP @ EI=1030.50 (S)
- (3) PROP PRVT CONNECTION 18" RCP @ EI=1020.90 (S)
- (4) REPLACE EXISTING CASTING WITH R-3067-7009 FOR MOUNTABLE CURB
- ** (5) STA OFFSET PROVIDED IS AT FACE OF CURB

REVISION - 4/5/19 SMITHGROUP
- New Sheet

SMITHGROUP

44 EAST MIFFLIN STREET
SUITE 500
MADISON, WI 53703
608.251.1177
www.smithgroup.com

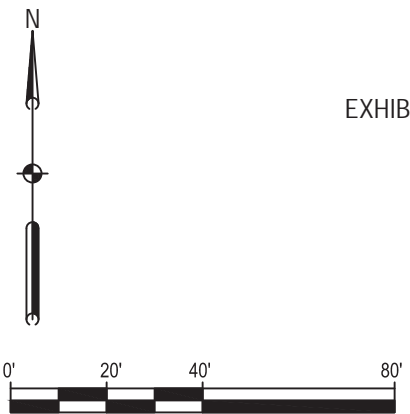
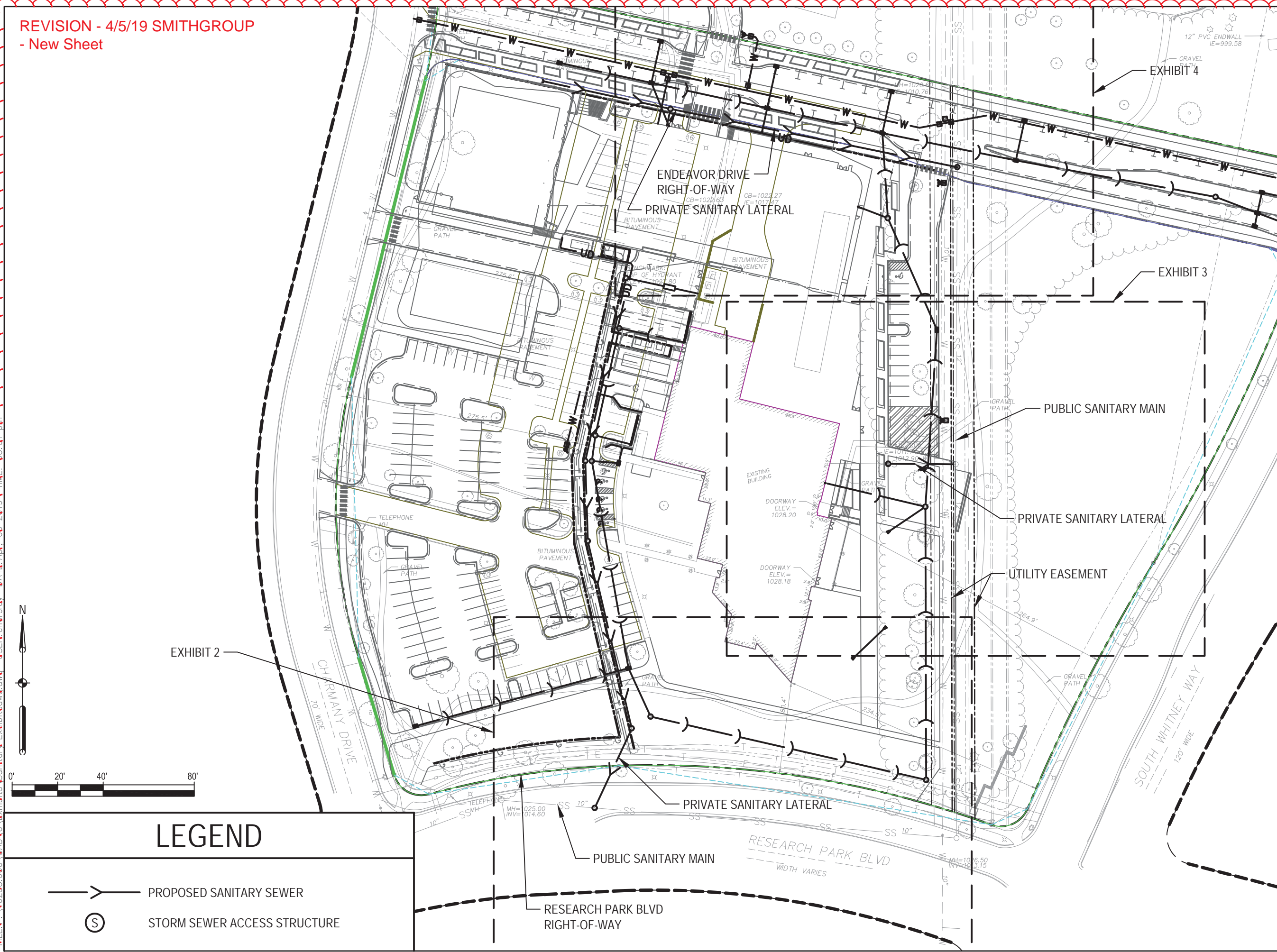
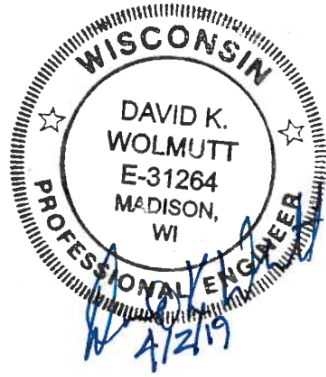

LEGEND	
	PROPOSED SANITARY SEWER
	STORM SEWER ACCESS STRUCTURE

SANITARY EXHIBIT - 1
DRAWING TITLE ENDEAVOR DRIVE -
CITY OF MADISON
ISSUED WITH
DRAWING REFERENCE
1" = 80'-0"
DRAWING SCALE
4/2/2019
DATE
UNIVERSITY RESEARCH PARK/ INNOVATION ONE
PROJECT NAME
10235.000
PROJECT NUMBER
EX-1
DRAWING NUMBER

SMITHGROUP

44 EAST MIFFLIN STREET
 SUITE 500
 MADISON, WI 53703
 608.251.1177
 www.smithgroup.com

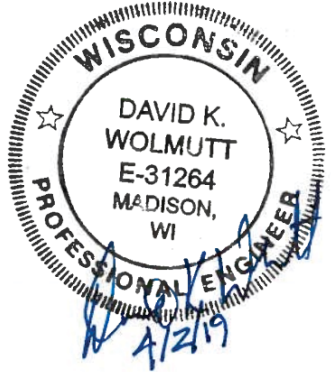

REVISION - 4/5/19
 SMITHGROUP
 - New Sheet

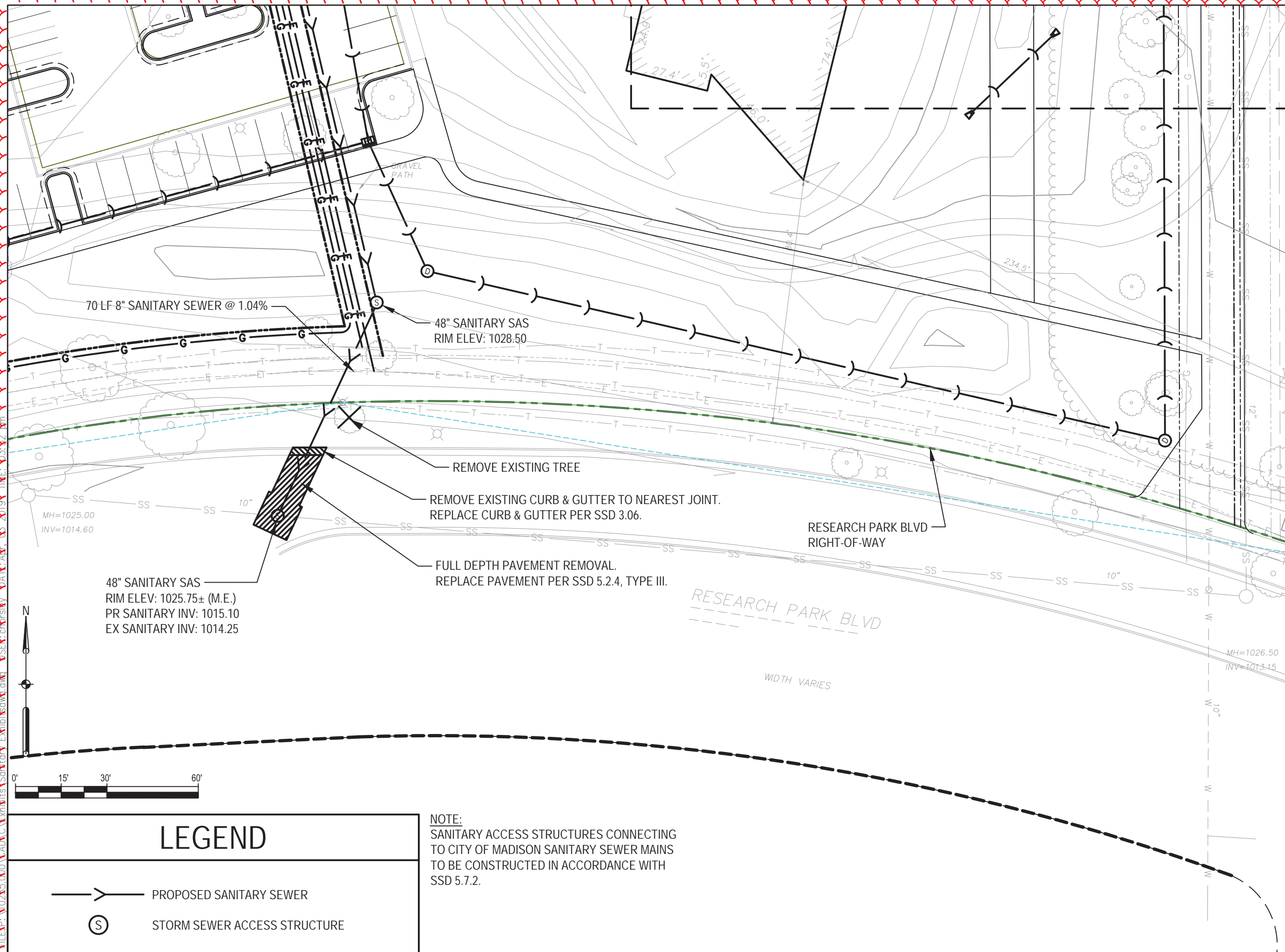

SANITARY EXHIBIT - 2

DRAWING TITLE
 ENDEAVOR DRIVE -
 CITY OF MADISON
 ISSUED WITH

DRAWING REFERENCE

1" = 30'-0"

DRAWING SCALE

4/2/2019

DATE
 UNIVERSITY RESEARCH PARK/
 INNOVATION ONE
 PROJECT NAME

10235.000

PROJECT NUMBER

EX-2

DRAWING NUMBER

LEGEND

- PROPOSED SANITARY SEWER
- STORM SEWER ACCESS STRUCTURE

NOTE:
 SANITARY ACCESS STRUCTURES CONNECTING
 TO CITY OF MADISON SANITARY SEWER MAINS
 TO BE CONSTRUCTED IN ACCORDANCE WITH
 SSD 5.7.2.

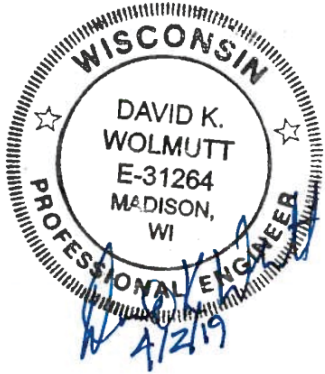

REVISION - 4/5/19
SMITHGROUP
- New Sheet

SANITARY EXHIBIT - 3

DRAWING TITLE
ENDEAVOR DRIVE -

CITY OF MADISON

ISSUED WITH

DRAWING REFERENCE

1" = 30'-0"

DRAWING SCALE

4/2/2019

DATE
UNIVERSITY RESEARCH PARK/
INNOVATION ONE

PROJECT NAME

10235.000

PROJECT NUMBER

EX-3

DRAWING NUMBER

NOTE:
SANITARY ACCESS STRUCTURES CONNECTING
TO CITY OF MADISON SANITARY SEWER MAINS
TO BE CONSTRUCTED IN ACCORDANCE WITH
SSD 5.7.2.

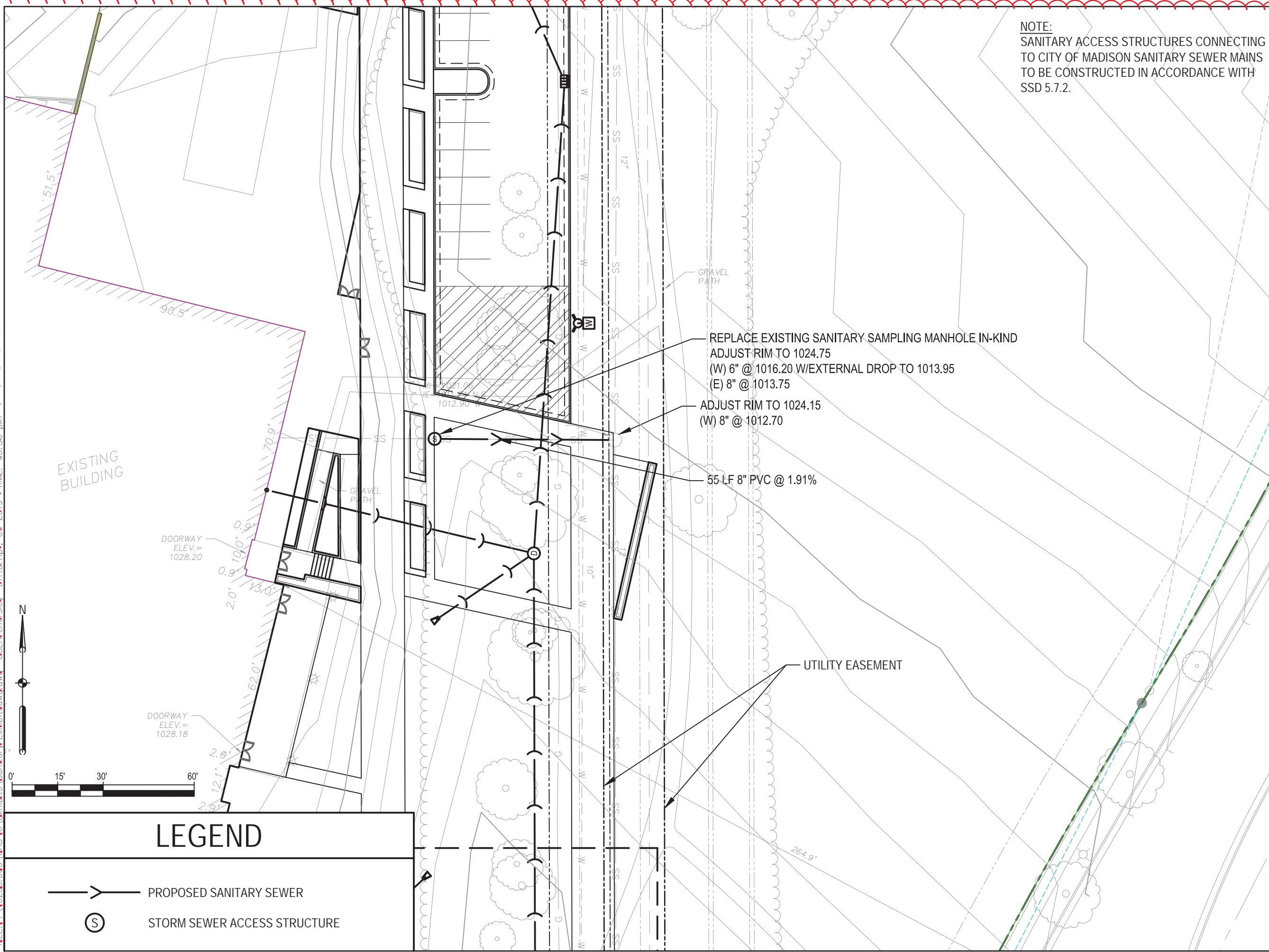



REPLACE EXISTING SANITARY SAMPLING MANHOLE IN-KIND
ADJUST RIM TO 1024.75
(W) 6" @ 1016.20 W/EXTERNAL DROP TO 1013.95
(E) 8" @ 1013.75

ADJUST RIM TO 1024.15
(W) 8" @ 1012.70

55 LF 8" PVC @ 1.91%

UTILITY EASEMENT

LEGEND

-  PROPOSED SANITARY SEWER
-  STORM SEWER ACCESS STRUCTURE

FILE: 02350000 ADV EXHIBIT SANITARY EXHIBIT.dwg DATE: 04/05/2019 TIME: 03:35 pm USER: chrisley

FILE: P:\119231\000\CAD\Exhibits\Sanitary Exhibit\swa.dwg USER: eholsiev DATE: Apr 03 2019 TIME: 05:33 pm

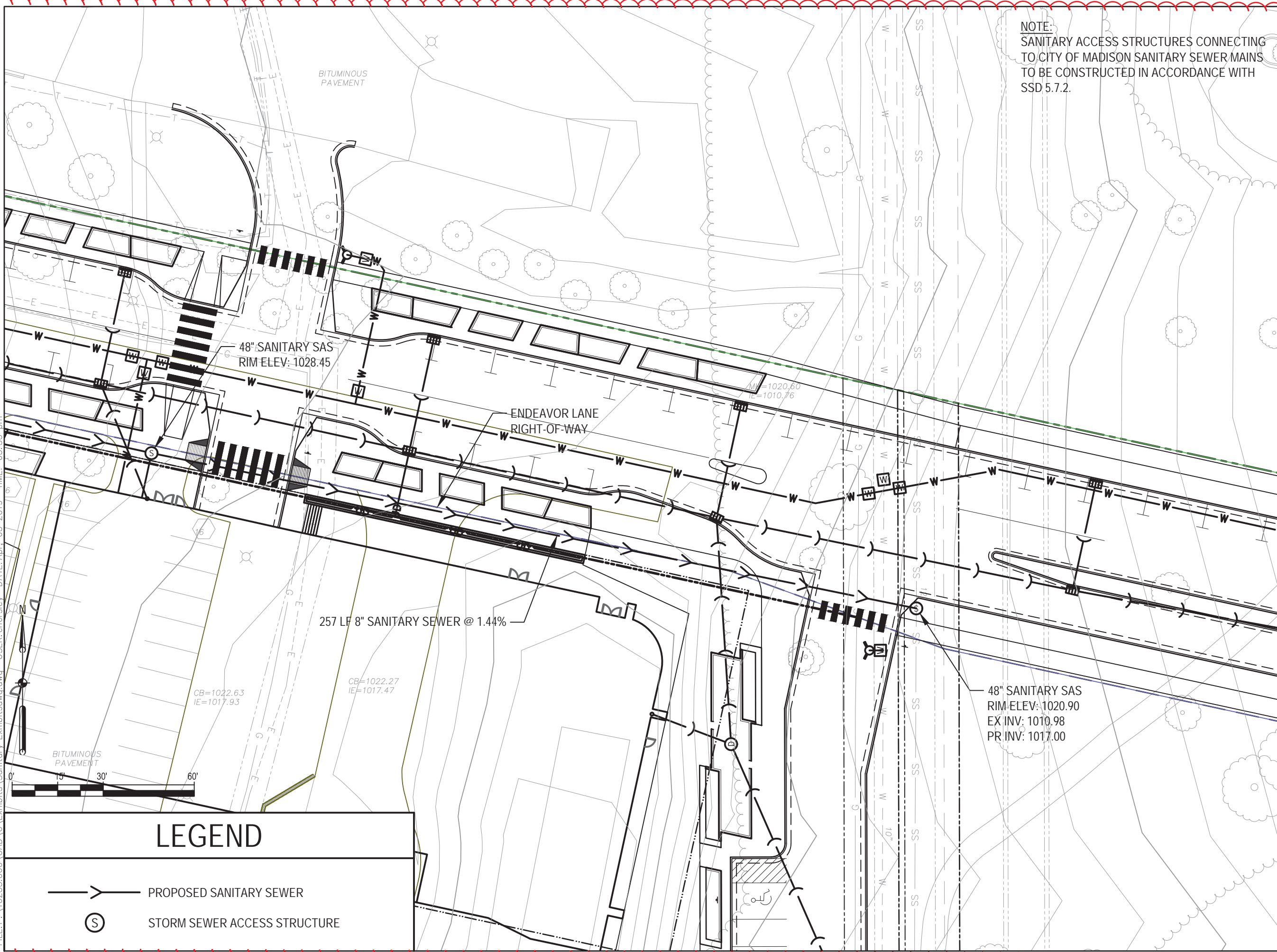

NOTE:
SANITARY ACCESS STRUCTURES CONNECTING
TO CITY OF MADISON SANITARY SEWER MAINS
TO BE CONSTRUCTED IN ACCORDANCE WITH
SSD 5.7.2.

SMITHGROUP

44 EAST MIFFLIN STREET
SUITE 500
MADISON, WI 53703
608.251.1177
www.smithgroup.com

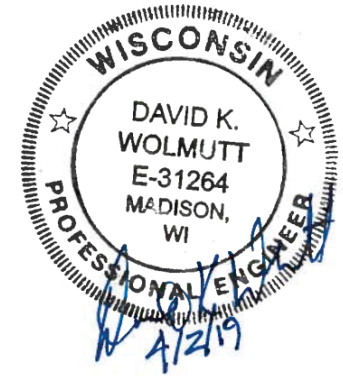

REVISION - 4/5/19
SMITHGROUP
- New Sheet

SANITARY EXHIBIT - 4
DRAWING TITLE
ENDEAVOR DRIVE -
CITY OF MADISON
ISSUED WITH



DRAWING REFERENCE
1" = 30'-0"
DRAWING SCALE

4/2/2019
DATE
UNIVERSITY RESEARCH PARK/
INNOVATION ONE
PROJECT NAME

10235.000
PROJECT NUMBER

EX-4
DRAWING NUMBER

LEGEND

-  PROPOSED SANITARY SEWER
-  STORM SEWER ACCESS STRUCTURE

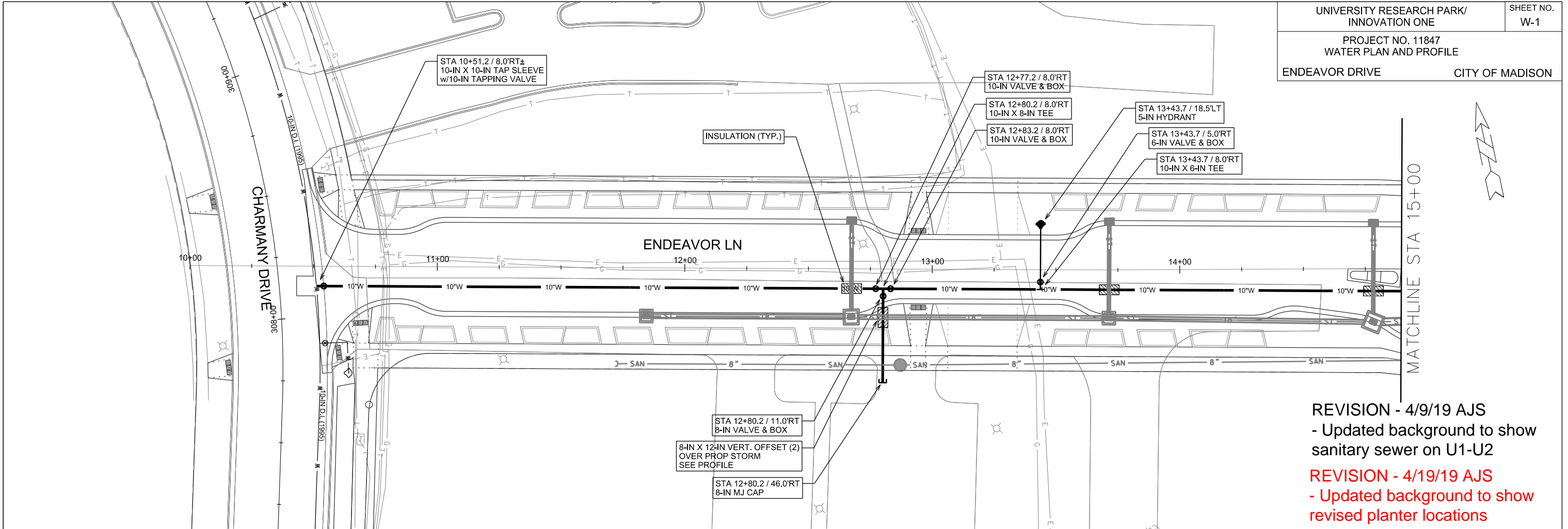

REVISION - 4/9/19 AJS
- Updated background to show sanitary sewer on U1-U2

REVISION - 4/19/19 AJS
- Updated background to show revised planter locations



PLOT SCALE:

PLOT NAME:

REV. DATE:

ORIGINATOR: CITY OF MADISON, STREETS DIVISION

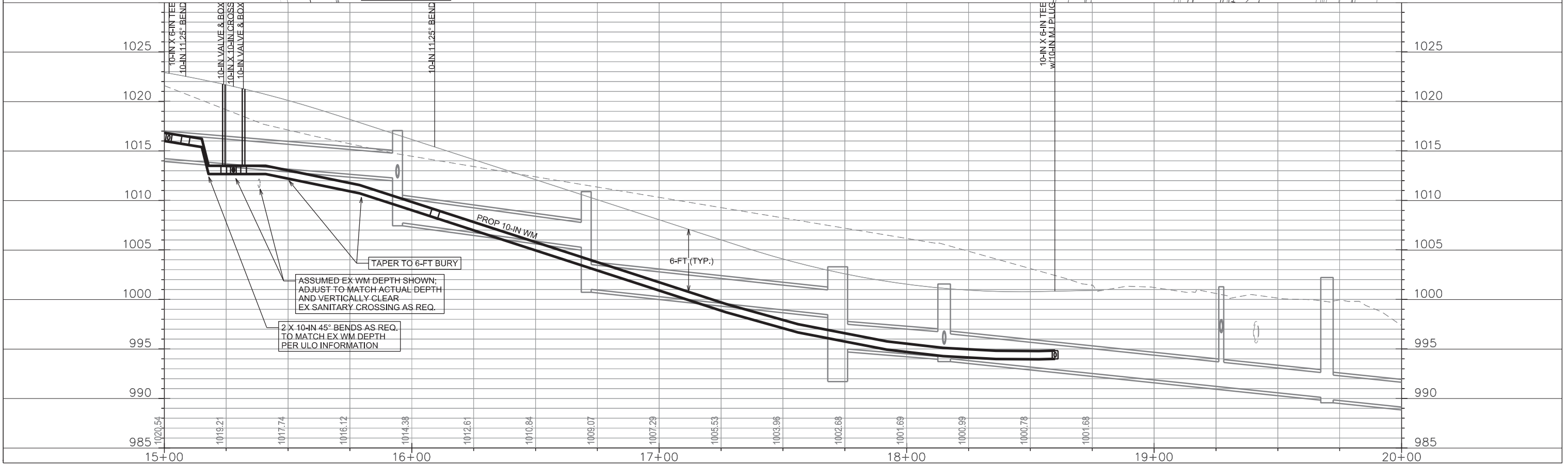
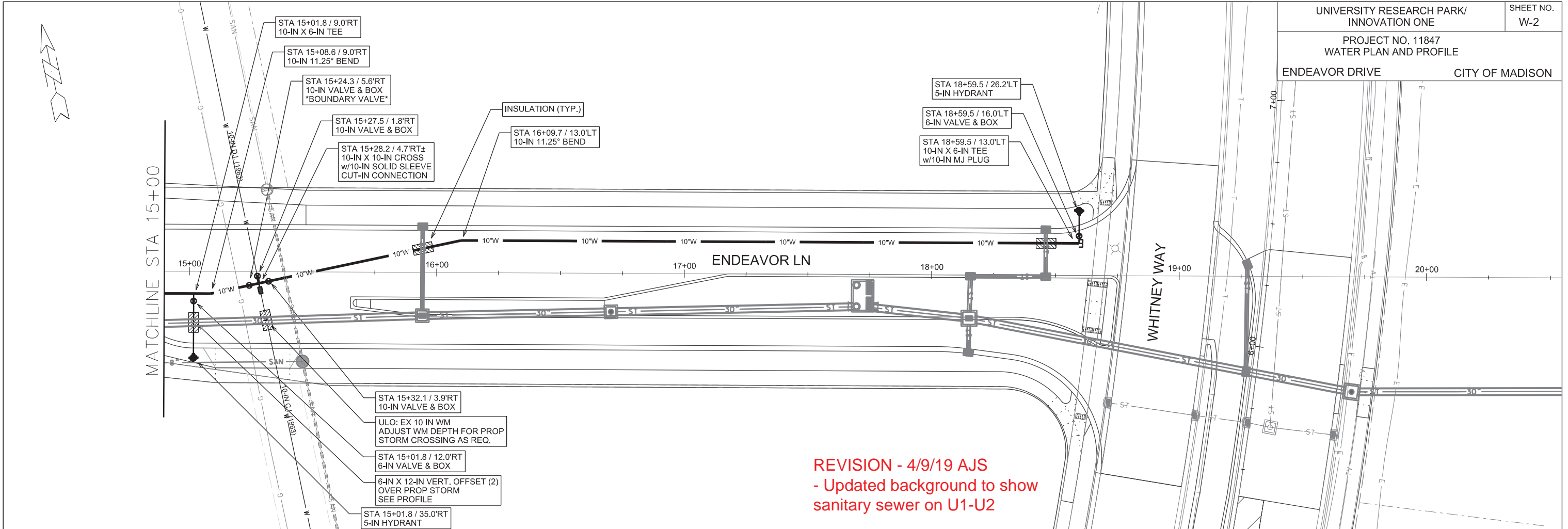

PLOT SCALE:

PLOT NAME:

REV. DATE:

ORIGINATOR: CITY OF MADISON, STREETS DIVISION

CONSTRUCTION NOTES:

- CONSTRUCT NEW WATER MAIN 6.0' BELOW FINISHED GRADE, UNLESS OTHERWISE NOTED. INSULATE MAIN WITH POLYSTYRENE BOARD AT STORM SEWER UTILITY CROSSINGS OR OTHER AREAS IDENTIFIED BY ENGINEER AS HAVING INADEQUATE COVER.
 - VERIFY SIZE OF EXISTING WATER SERVICES AND RECONNECT SERVICES AS INDICATED.
 - MINIMIZE DISRUPTION OF SERVICE TO EXISTING CUSTOMERS. NOTIFY PER CONTRACT REQUIREMENTS OF ANY PLANNED WATER OUTAGE.
 - THE EXISTING UTILITIES SHOWN ON THIS PLAN REPRESENT THE BEST INFORMATION AVAILABLE TO THE WATER UTILITY AT THE TIME OF PLAN PREPARATION. CONTRACTOR IS RESPONSIBLE FOR HAVING EACH UTILITY LOCATED PRIOR TO COMMENCING WORK.
- WN1 REPLACE THE EXISTING LEAD SERVICE WITH A NEW COPPER SERVICE.
- WN2 EXTEND AND RECONNECT THE EXISTING COPPER SERVICE FROM THE OLDER WATER MAIN TO THE NEWER WATER MAIN.
- WN3 EXISTING SERVICE TO BE ABANDONED WHEN THE WATER MAIN IS CUT OFF; ABANDON CURB BOX AS REQUIRED.
- WN4 DISCONNECT FROM THE OLDER WATER MAIN AND RECONNECT THE EXISTING COPPER WATER SERVICE LATERAL TO THE NEWER WATER MAIN.
- WN5 RELOCATE THE EXISTING FIRE HYDRANT.
- WN6 ABANDON WATER VALVE ACCESS STRUCTURE.
- WN7 FURNISH AND INSTALL THE NEW TOP SECTION FOR THE WATER ACCESS STRUCTURE.
- WN8 ABANDON THE VALVE BOX.
- WN9 FURNISH THE DITCH, COMPACTION, AND ALL MATERIALS AND LABOR FOR THE INSTALLATION OF NEW SERVICE LATERAL.
- WN10 REMOVE AND SALVAGE EXISTING HYDRANT
- WN11 REPLACE THE EXISTING COPPER SERVICE WITH A COPPER SERVICE

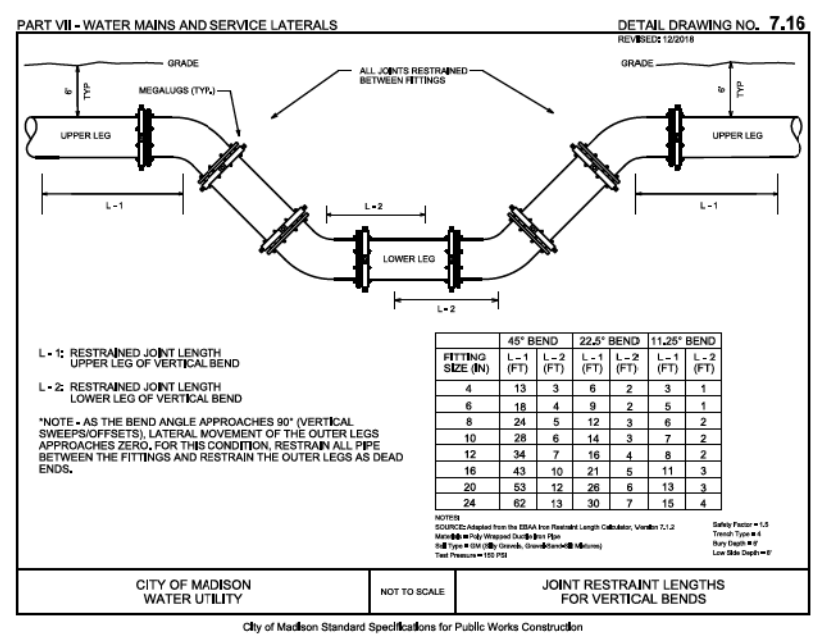

ESTIMATE OF PROJECT WATER MATERIALS - FROM CONTRACTOR:

* ESTIMATE OF MATERIALS IS FOR INFORMATION ONLY. ENGINEER DOES NOT GUARANTEE ACCURACY OF MATERIAL TAKE-OFF. ALWAYS REFER TO PLANS.

WATER ASSETS	TOTAL
6-IN PIPE (LF)	70
8-IN PIPE (LF)	40
10-IN PIPE (LF)	820
POLY WRAP	1050
6-IN VALVE & BOX	3
8-IN VALVE & BOX	1
10-IN VALVE & BOX	5
10-IN - 11.25° BEND	2
10-IN - 45° BEND (AS REQ.)	2
10-IN X 6-IN TEE	3
10-IN X 8-IN TEE	1
10-IN X 10-IN CROSS	1
10-IN SOLID SLEEVE	1
5-IN HYDRANT	3
10-IN MJ PLUG	1
8-IN MJ CAP	1
2-IN STYROFOAM (LF)	64
6-IN X 12-IN OFFSET	2
8-IN X 12-IN OFFSET	2
10-IN X 7-IN OFFSET (AS REQ.)	2

TO OBTAIN LOCATION OF PARTICIPANTS' UNDERGROUND FACILITIES BEFORE YOU DIG IN WISCONSIN

CALL DIGGERS HOTLINE
TOLL FREE
811 OR 1-800-242-8511
FAX-A-LOCATE 1-800-338-3860
TDD (FOR HEARING IMPAIRED) 1-800-542-2289

WIS. STATUTE 182.0175 (1974)
REQUIRES MIN. OF 3 WORK DAYS
NOTICE BEFORE YOU EXCAVATE.

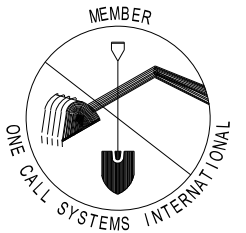

= APPLY STYROFOAM INSULATION OVER THE WATER MAIN AND SERVICES AT STORM SEWER CROSSINGS, PER STANDARD SPECIFICATIONS

ESTIMATE OF PROJECT WATER MATERIALS - FROM CITY:

* ESTIMATE OF MATERIALS IS FOR INFORMATION ONLY. ENGINEER DOES NOT GUARANTEE ACCURACY OF MATERIAL TAKE-OFF. ALWAYS REFER TO PLANS.

WATER ASSETS	TOTAL
10-IN TAPPING VALVE & BOX	1
10-IN X 10-IN TAPPING SLEEVE	1

UTILITY LINE OPENINGS (ULO):

STATION / OFFSET	
15+33 / 8.0'RT	WATER

DISCLAIMER NOTE:
UTILITY LOCATIONS SHOWN ARE APPROXIMATE ONLY. IT SHALL BE THE CONTRACTOR'S RESPONSIBILITY TO DETERMINE THE EXACT HORIZONTAL AND VERTICAL LOCATION OF ALL EXISTING UNDERGROUND AND OVERHEAD UTILITIES PRIOR TO COMMENCING WORK.

PART VII - WATER MAINS AND SERVICE LATERALS DETAIL DRAWING NO. 7.04
REVISED: 12/2018

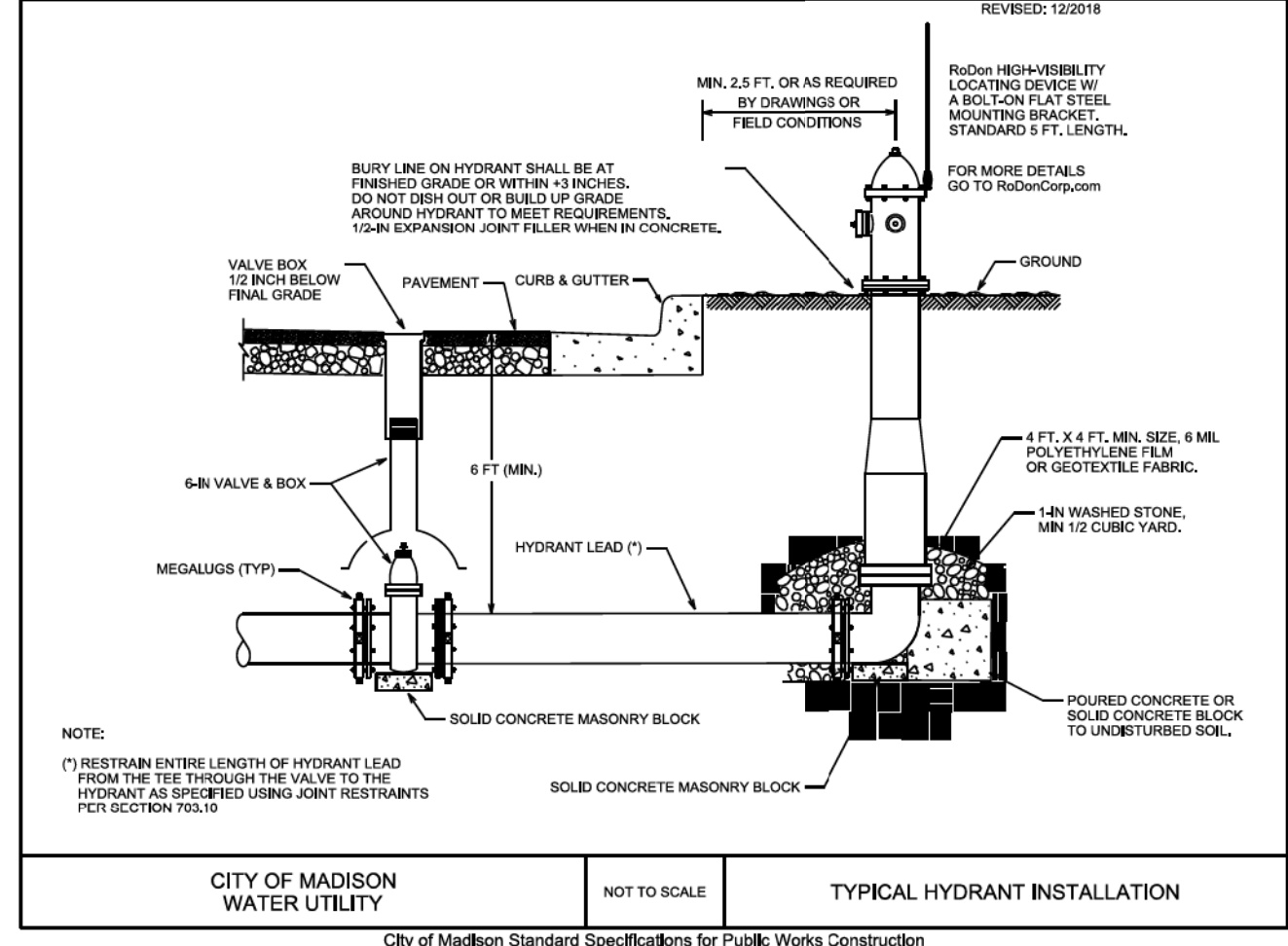

PLOT SCALE:

PLOT NAME:

REV. DATE:

ORIGINATOR: CITY OF MADISON, STREETS DIVISION

SCALE: 1" = 30'

GENERAL ELECTRICAL NOTES:

1. ALL LOCATIONS ARE APPROXIMATE. THE TRAFFIC ENGINEER SHALL APPROVE FINAL LOCATIONS INCLUDING SETBACK IN THE FIELD. AFTER CONTRACTOR SURVEYS STAKING, THE CONTRACTOR SHALL NOTIFY GRETCHEN AVILES PINEIRO (266-4899) CITY TRAFFIC ENGINEERING, AT LEAST 24-HOURS IN ADVANCE OF NEEDING BASE LOCATIONS MARKED.
2. THE CONTRACTOR SHALL DO ALL WORK IN ACCORDANCE WITH CITY OF MADISON STANDARD SPECIFICATIONS FOR PUBLIC WORKS CONSTRUCTION 2019 EDITION AND ALL ADDENDUMS THERETO. ALL CONDUIT SHALL BE PVC SCHEDULE 80 UNDER PAVEMENT OR SCHEDULE 40 OTHERWISE. PULL WIRE REQUIRED AS PER STANDARD SPECIFICATIONS.
3. THE CONTRACTOR SHALL CALL TROY VANT (266-4767) AT THE TRAFFIC ENGINEERING SHOP AT LEAST 24-HOURS IN ADVANCE OF POURING BASES, BURYING CONDUIT AND CONSTRUCTING ELECTRICAL HANDHOLES TO ARRANGE FOR INSPECTION.
4. ALL EXISTING CONDUITS AND STREET LIGHTS ARE TO REMAIN UNLESS AND UNTIL AUTHORIZED TO REMOVE BY TRAFFIC ENGINEERING. EXISTING CONDUITS CROSSING ENDEAVOR LN, AND EXISTING STREET LIGHT SL 6158 CAN NOT BE REMOVED UNTIL AFTER THE CONTRACTOR INSTALLS THE TWO WOOD TEMPORARY WOOD POLES SHOWN ON THE PLAN AND CITY TE CREWS HAVE INSTALL TEMPORARY OVERHEAD SIGNAL AND LIGHTING CABLES REQUIRED TO MAINTAIN THE EXISTING STREET LIGHT CIRCUIT ON WHITNEY WAY.
5. THE FOLLOWING CITY FURNISHED MATERIALS ARE TO BE PICKED UP AT THE TRAFFIC TRAFFIC OPERTION SHOP, 1120 SAYLE STREET. NOTIFY ED SMITH AT 266-9034 TWENTY FOUR (24) HOURS PRIOR TO PICKING UP THE MATERIAL:

1" X 40" ANCHOR BOLTS: 20

LEGEND

- PLACE STREET LIGHTING PVC CONDUIT, 2" UNLESS NOTED AS OTHER
- PLACE SIGNAL/COMMUNICATION PVC COUNDUIT, 2-3" UNLESS NOTED AS OTHER
- EXISTING STREET LIGHTING CONDUIT
- ☐ CONSTRUCT TYPE-1 ELECTRICAL HANDHOLE
- ⊗ CONSTRUCT LB-3 CONCRETE BASE MODIFIED TO HAVE 11.5 INCH BOLT CIRCLE
- ⊗ EXISTING STREET LIGHT POLE/BASE
- ⊕ TEMPORARY 30 FOOT WOOD POLE TO BE INSTALLED AND REMOVED BY CONTRACTOR

CONSTRUCT TYPE-1
ELECTRICAL HANDHOLE
(TYPICAL)

CONSTRUCT LB-3
CONCRETE BASE
11.5" B.C.
(TYPICAL)

INSTALL 2" PVC
(TYPICAL)

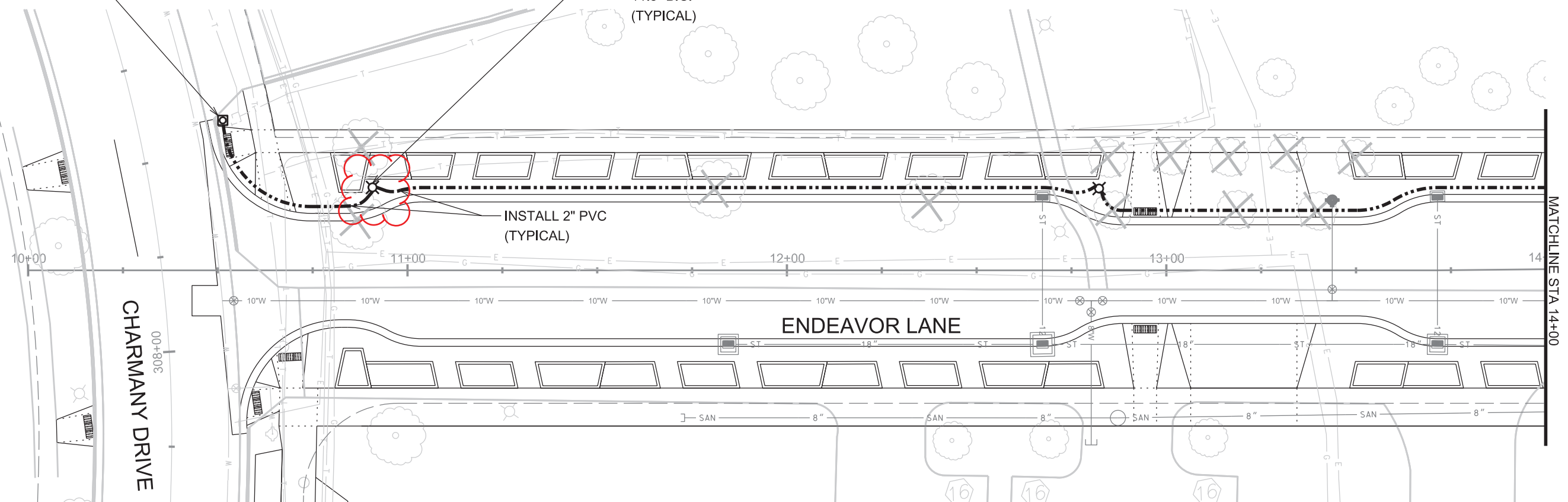

PLOT SCALE:

PLOT NAME:

REV. DATE:

ORIGINATOR: CITY OF MADISON, TRAFFIC ENG. DIV.

SCALE: 1" = 30'

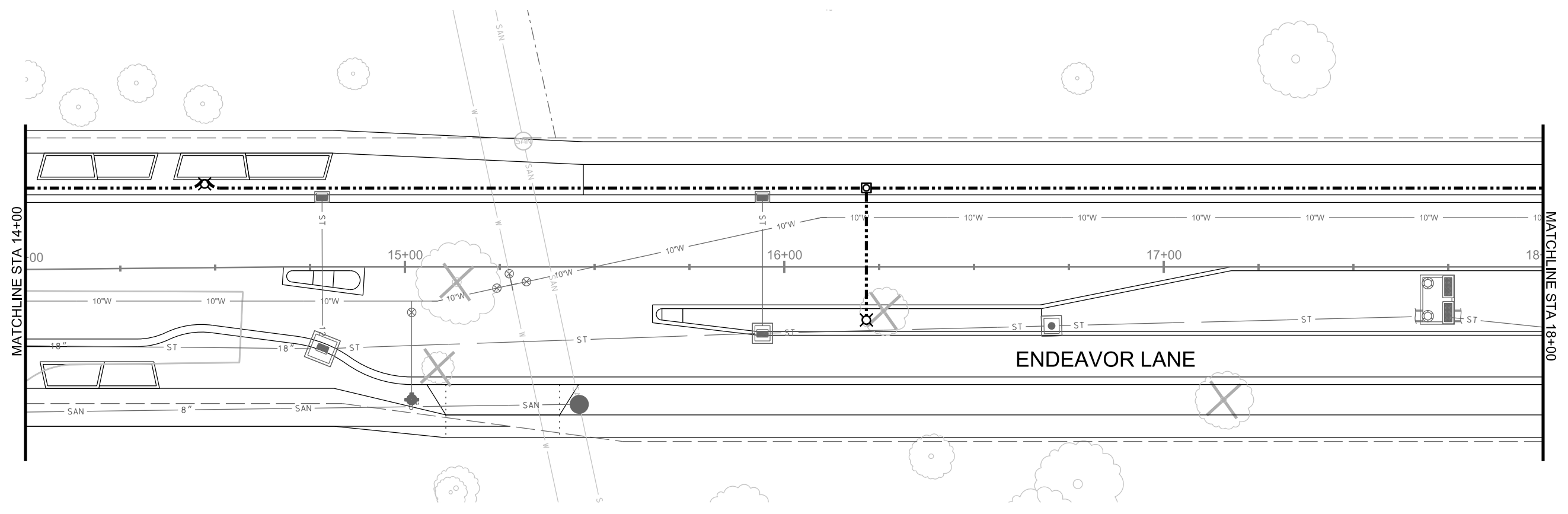

LEGEND

- PLACE STREET LIGHTING PVC CONDUIT, 2" UNLESS NOTED AS OTHER
- PLACE SIGNAL/COMMUNICATION PVC CONDUIT, 2-3" UNLESS NOTED AS OTHER
- EXISTING STREET LIGHTING CONDUIT
- ☐ CONSTRUCT TYPE-1 ELECTRICAL HANDHOLE
- ⊗ CONSTRUCT LB-3 CONCRETE BASE MODIFIED TO HAVE 11.5 INCH BOLT CIRCLE
- ⊗ EXISTING STREET LIGHT POLE/BASE
- ✦ TEMPORARY 30 FOOT WOOD POLE TO BE INSTALLED AND REMOVED BY CONTRACTOR

PLOT SCALE:
 PLOT NAME:
 REV. DATE:
 ORIGINATOR: CITY OF MADISON, TRAFFIC ENG. DIV.

ELECTRICAL PLAN

ENDEAVOR LANE CITY OF MADISON
REV 5/3/2019 GMA

SCALE: 1" = 30'

PLOT SCALE:

PLOT NAME:

REV. DATE:

ORIGINATOR: CITY OF MADISON, TRAFFIC ENG. DIV.

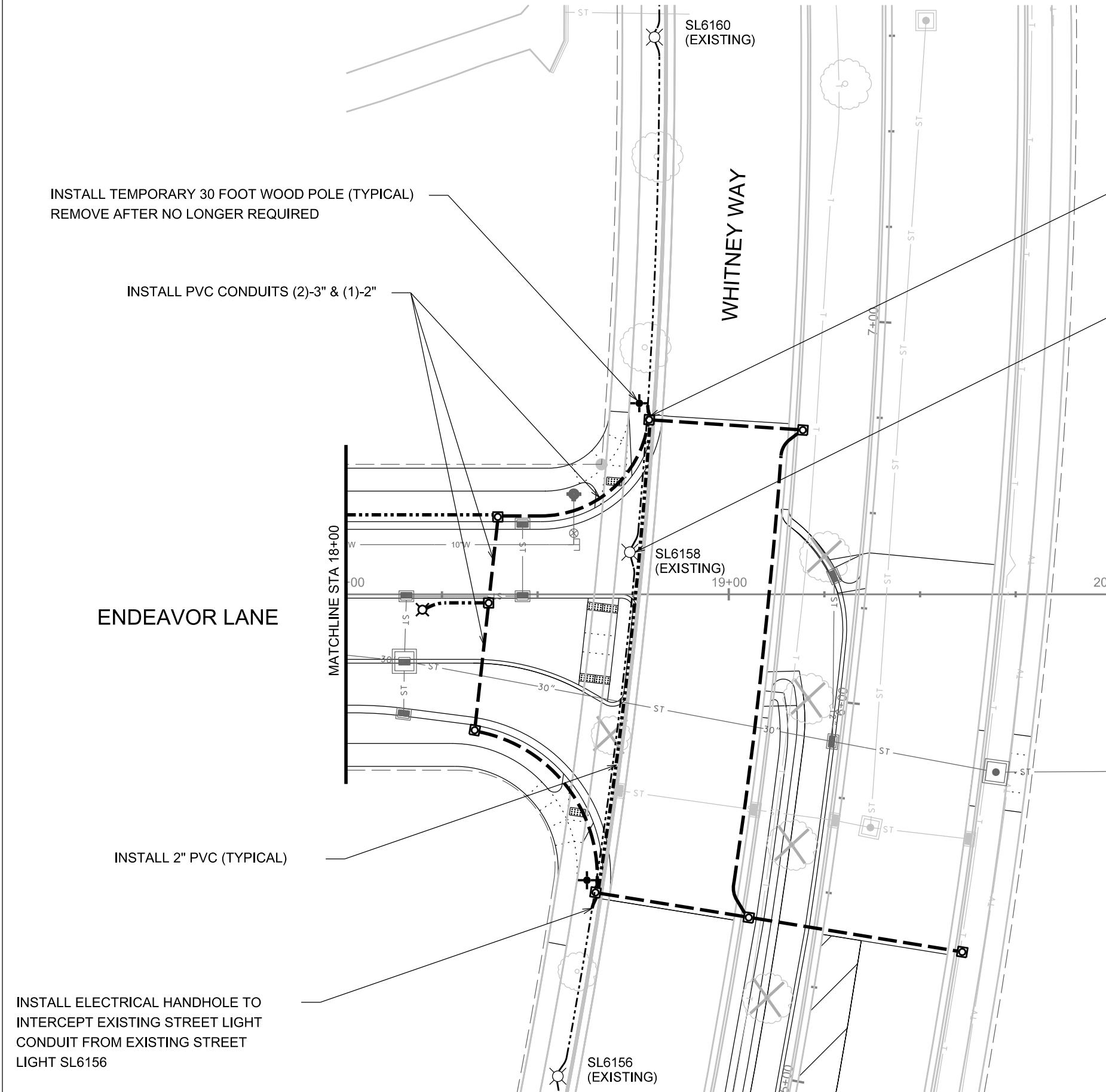

INSTALL TEMPORARY 30 FOOT WOOD POLE (TYPICAL)
REMOVE AFTER NO LONGER REQUIRED

INSTALL PVC CONDUITS (2)-3" & (1)-2"

ENDEAVOR LANE

INSTALL 2" PVC (TYPICAL)

INSTALL ELECTRICAL HANDHOLE TO
INTERCEPT EXISTING STREET LIGHT
CONDUIT FROM EXISTING STREET
LIGHT SL6156

WHITNEY WAY

SL6160
(EXISTING)

SL6158
(EXISTING)

SL6156
(EXISTING)

INSTALL ELECTRICAL HANDHOLE TO
INTERCEPT EXISTING STREET LIGHT CONDUIT
FROM EXISTING STREET LIGHT SL6160

REMOVE CONCRETE BASE
REMOVE & DELIVER STREET LIGHT POLE/ARM/FIXTURE
TO TRAFFIC ENGINEERING SHOP. NOTIFY ED SMITH AT
266-9034 TWENTY FOUR (24) HOURS PRIOR TO DELIVERY

LEGEND

- PLACE STREET LIGHTING PVC CONDUIT, 2" UNLESS NOTED AS OTHER
- PLACE SIGNAL/COMMUNICATION PVC CONDUIT, 2-3" UNLESS NOTED AS OTHER
- EXISTING STREET LIGHTING CONDUIT
- ☐ CONSTRUCT TYPE-1 ELECTRICAL HANDHOLE
- ⊗ CONSTRUCT LB-3 CONCRETE BASE MODIFIED TO HAVE 11.5 INCH BOLT CIRCLE
- ⊗ EXISTING STREET LIGHT POLE/BASE
- ⊕ TEMPORARY 30 FOOT WOOD POLE TO BE INSTALLED AND REMOVED BY CONTRACTOR

UNIVERSITY RESEARCH PARK - INNOVATION ONE MADISON, WI

PROJECT NAME
INNOVATION ONE
PROJECT ADDRESS
510 (HARMANY, MADISON, WI 53719)



ARCHITECT
VALERIO DEWALT TRAIN ASSOCIATES, INC.
500 N. DEARBORN, 9TH FLOOR
CHICAGO, ILLINOIS 60654
312.260.7300
www.bulldordie.com
PROJECT TEAM ARCHITECT STAMP

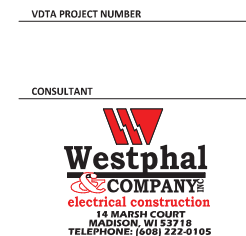

CONSULTANT PROJECT NUMBER
1840005

ISSUE		
NO.	REVISION DESCRIPTION	DATE
2	95% CONSTRUCTION DOCUMENTS	07/20/18
4	100% CONSTRUCTION DOCUMENTS	08/29/18
6	ISSUED FOR CONSTRUCTION	10/11/18
19	ISSUED FOR CONSTRUCTION	04/26/19

© 2017 VALERIO DEWALT TRAIN ASSOCIATES, INC.

SHEET TITLE
SYMBOLS AND ABBREVIATIONS



SHEET NUMBER
E0-01

ABBREVIATIONS

10/100BaseTX	ETHERNET FAST ETHERNET	JB	JUNCTION BOX
100BaseSX	GIANT ETHERNET (SHORT WAVELENGTH)	KO	KNOCKOUT
100BaseLX	GIANT ETHERNET (LONG WAVELENGTH)	KV	KILOVOLT
A	AMPERES	KVA	KILOVOLT-AMPERES
AC	ACROSS	KW	KILOWATTS
ACS	ACCESS CONTROL SYSTEM	KWH	KILOWATT HOURS
ACT	AC THERMAL CONTROLLER	LAN	LOCAL AREA NETWORK
ADO	ACCESS CONTROL DEVICE	LGT	LIGHT
AF	AMPERE FRAME	LTPC	LOCAL TEMPERATURE CONTROL PANEL
AFF	ABOVE FINISHED FLOOR	LTS	LIGHTING
AG	AMP INTERRUPTING CAPACITY	LTV	LOW VOLTAGE
ALT	ALTERNATE	LTV	LOW VOLTAGE
ARCH	ARCHITECTURAL	MATV	MASTER ANTENNA TELEVISION
ASC	ABOVE SUSPENDED CEILING	MC	MECHANICAL CONTRACTOR
AT	AUTOMATIC TRANSFER SWITCH	MCB	MAIN CIRCUIT BREAKER
AUTO	AUTOMATIC	MCC	MOTOR CONTROL CENTER
AWG	AMERICAN WIRE GAUGE	MCP	MOTOR CIRCUIT PROTECTOR
BAS	BUILDING AUTOMATION SYSTEM	MD	MAIN DISTRIBUTION FACILITY
BATS	BYPASS AUTOMATIC TRANSFER SWITCH	MDP	MAIN DISTRIBUTION PANEL
BC	BARE COPPER	MER	MAIN EQUIPMENT ROOM
BCK	BUILDING CONTROL SYSTEM	MLO	MANUALLY LOCKED
BEF	BUILDING ENTRANCE FACILITY	MH	MAINTENANCE HOLE
BFC	BELOW FINISH CEILING	MM	MULTI-MODE
BFL	BELOW FLOOR LEVEL	MP	MUSIC PAGE
BLDG	BUILDING	MPTB	MUSIC & PAGE TERMINAL BOX
BMS	BUILDING MANAGEMENT SYSTEM	MTD	MOUNTED
BPP	BOILER PLANT INSTRUMENTATION PANEL	MTG	MOUNTING
BRKR	BREAKER	MTG HGT	MOUNTING HEIGHT
C	CONDUIT	MTR	MOTOR METER
CCTV	CLOSED CIRCUIT TELEVISION	NA	NOT APPLICABLE
CCT	CIRCUIT	NC	NEW CONNECTION NORMALLY CLOSED
CB	CIRCUIT BREAKER	NEC	NATIONAL ELECTRICAL CODE
CB/CCT BRK	CIRCUIT BREAKER	NFD	NON-FUSED DISCONNECT
CLO	CEILING	NFIS	NON-FUSED SAFETY SWITCH
CO	CONDUIT ONLY	NI	NOT IN CONTRACT
CONN	CONNECTION	NO	NORMALLY OPEN
CONTR	CONTRACTOR	NTS	NOT TO SCALE
CORR	CORRIDOR	OFCI	OWNER FURNISHED CONTRACTOR INSTALLED
CP	CONSOLIDATION POINT	OFI	OWNER FURNISHED OWNER INSTALLED
CT	CURRENT TRANSFORMER/CABLE TRAY	P	POLE
DB	DIRECT BURIAL	PA	PUBLIC ADDRESS
DC	DIRECT CURRENT	PB	PULL BOLL PLUSH/SHUTTER
DED	DEDICATED	PBX	PRIVATE BRANCH EXCHANGE
DET	DETAIL	PC	PLUMBING CONTRACTOR/PERSONAL COMPUTER
DIA	DIAMETER	PDU	POWER DISTRIBUTION UNIT
DISC	DISCONNECT	PF	POWER FACTOR
DONK	DONKEY	PH	PHASE
DP	DISTRIBUTION PANEL	PLBG	PLUMBING
DS	DISCONNECT SWITCH	PML	PANEL
DUR	DURABLE	POD	PANEL OPERATED DAMPER
EC	EMPTY CONDUIT/ELECTRICAL CONTRACTOR	PT	POTENTIAL TRANSFORMER
ECL	EMERGENCY CRITICAL LIGHTING	PTV	POWER TYPE ROOF VENTILATOR
ECC	EMERGENCY CRITICAL CABLE	PNR	POWER
EDB	ELECTRIC DUCT BANK	RECD	RECESSED
EF	ENTRANCE FACILITY	RECFP	RECEPTACLE
EG	EQUIPMENT GROUND	REL	RELOCATE
EGS	ENGINE GENERATOR SET	REQD	REQUIRED
EQIF	EQUIPMENT INTERMEDIATE DISTRIBUTION FACILITY	RGP	REMOTE GROUND INDICATOR PANEL
EJ	EXPANSION JOINT	RMC	RIGID METAL CONDUIT
ELEC	ELECTRICAL/ELECTRICAL	RJ	RACK UNIT
ELL	EMERGENCY LIFE SAFETY LIGHTING	RVIT	REDUCED VOLTAGE AUTO TRANSFER
ELP	EMERGENCY LIFE SAFETY POWER	SHT	SHIELD
EMER	EMERGENCY	SH	SIGNAL
EMI	ELECTROMAGNETIC INTERFERENCE	SM	SMALL
EMT	ELECTRICAL METALLIC TUBING	SO	STANDARD INFORMATION OUTLET
EQUIP	EQUIPMENT	SIN	SINGLE SINE
ER	EQUIPMENT ROOM	SPEC	SPECIFICATION
ESM	ELECTRICAL STRIP MOLD	SS	SAFETY SWITCH
ETR	EXISTING TO REMAIN	STA	STARTER
EWC	ELECTRIC WATER COOLER	STA	STARTER
EXT	EXTERNAL	SW	SWITCH
FAC	FLOOR ABOVE	SWB	SWITCHBOARD
FIF	FLUSH WITH FINISHED FLOOR	SWG	SWITCHGEAR
FFW	FLUSH WITH FINISHED WALL	TB	TERMINAL BOX
FA	FIRE ALARM	TEL	TELEPHONE
FACP	FIRE ALARM CONTROL PANEL	TFA	TO FLOOR ABOVE
FCU	FAN COIL UNIT	TFB	TO FLOOR BELOW
FER	FEEDER	TO	TELECOMMUNICATIONS OUTLET
FOS	FUSED DISCONNECT SWITCH	TR	TELECOM ROOM
FI	FI LUMINAIR	TS	TAMPER SWITCH/TIME SWITCH
FIT	FIXTURE	TV	TELEVISION
FL	AT FLOOR LINE	TVSS	TRANSIENT VOLTAGE SURGE SUPPRESSION
FLA	FULL LOAD AMPERES	TVTC	TELEVISION TERMINAL CABINET
FLEX	FLEXIBLE	TYP	TYPICAL
FLR	FLOOR	UC	UNDER COUNTER
FLUOR	FLUORESCENT	UG	UNDERGROUND
FS	FLOW SWITCH	UH	UNIT HEATER
FSS	FUSED SAFETY SWITCH	UN	UNLESS NOTED OTHERWISE
FSCP	FLAME SAFEGUARD CONTROL PANEL	UPS	UNINTERRUPTIBLE POWER SUPPLY
FWR	FULL VOLTAGE NON-REVERSING	V	VOLTAGE
GBC	GIANT INTERFACE CONVERTER	VFD	VARIABLE FREQUENCY DRIVE
GC	GENERAL CONTRACTOR	VOP	VOICE OVER INTERNET PROTOCOL
GFCI	GROUND FAULT CIRCUIT INTERRUPTER	VP	VAPOR PROOF
GND	GROUND	W	WIRE
GEN	GENERATOR	W	WITH
GRC	GALVANNEED RIBD CONDUIT	WP	WEATHERPROOF
GTB	GROUND TERMINAL BOX	WS	WALL SURFACE
HH	HANDHOLE	WT	WATER TIGHT
HDA	HAND OFF AUTOMATIC	WBT	WATER TIGHT
HP	HORSE POWER	X	EXPLOSION PROOF
HT	HIGH-TEMPERATURE TRACE	XFMR	TRANSFORMER
HV	HIGH VOLTAGE	XP	EXPLOSION PROOF
IDF	INTERMEDIATE DISTRIBUTION FACILITY		
IMC	INTERMEDIATE METAL CONDUIT		
INCAND	INCANDESCENT		

SHEET SYMBOLS

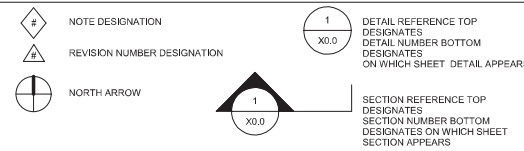

POWER RECEPTACLES

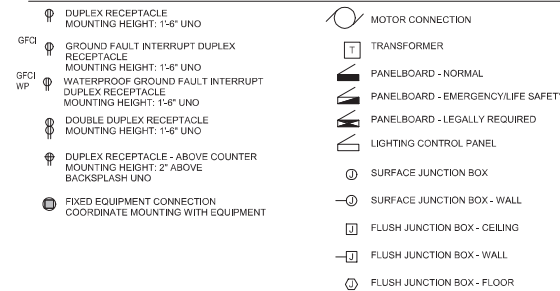

FIRE ALARM

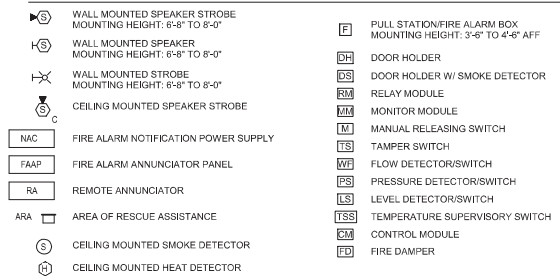

SITE SYMBOLS

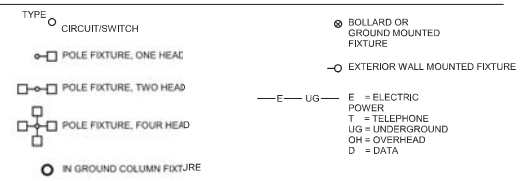

LIGHTING

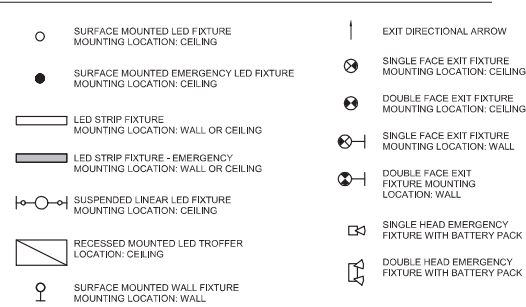

SWITCHES

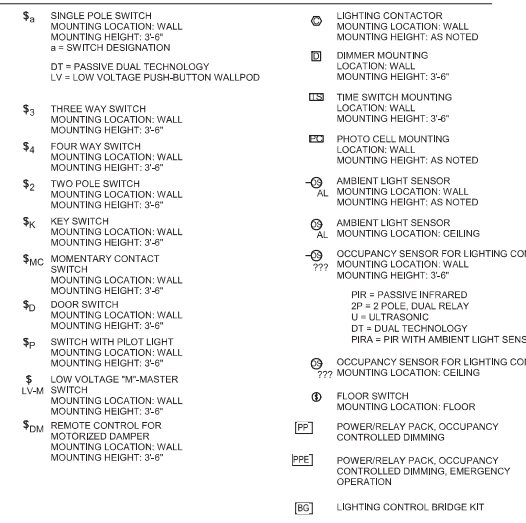

DATA DEVICES



A B C D E F G H I J K L M

8 7 6 5 4 3 2 1

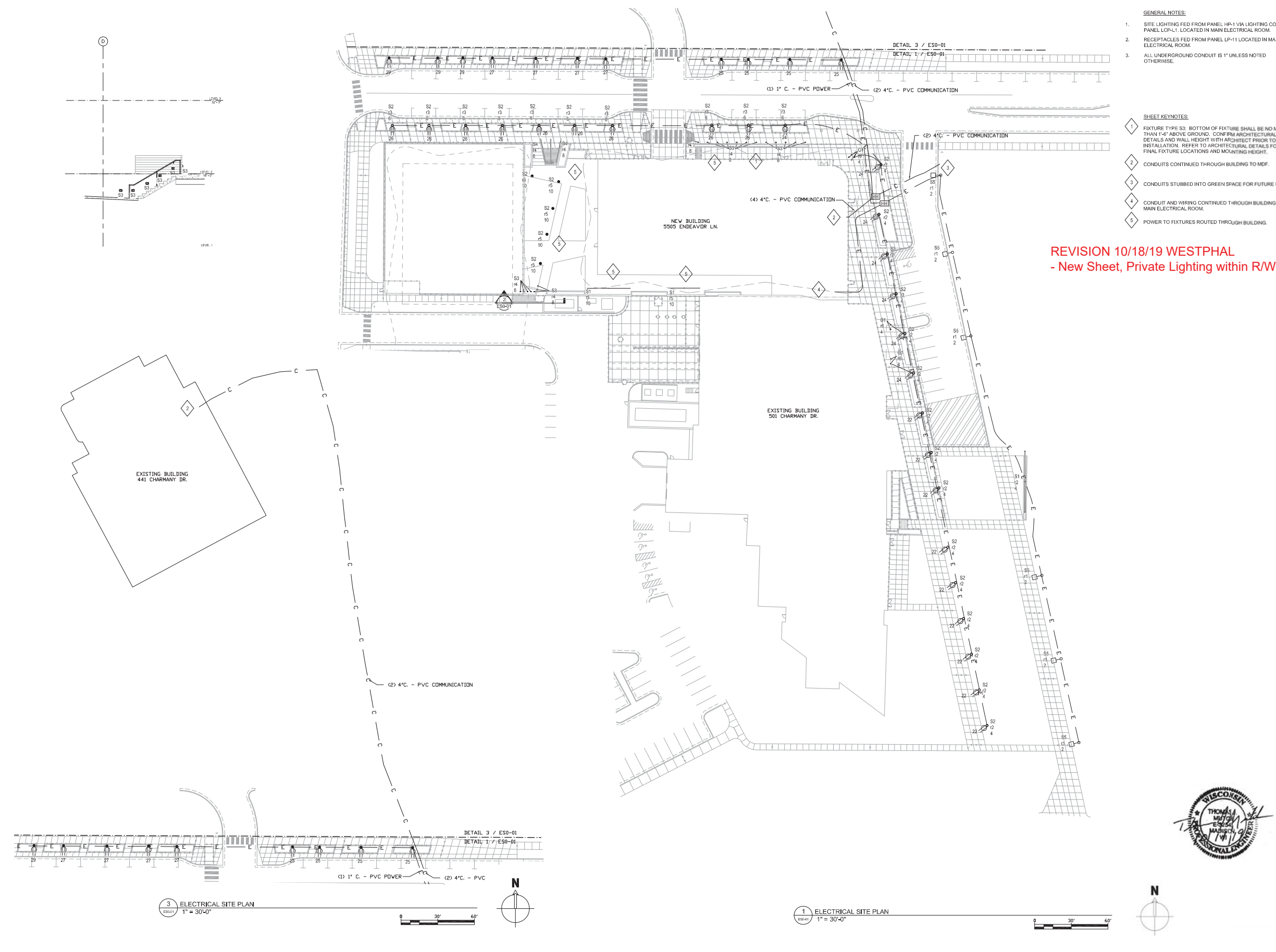

- GENERAL NOTES:**
- SITE LIGHTING FED FROM PANEL HR-1 VIA LIGHTING CONTROL PANEL LOP-L. LOCATED IN MAIN ELECTRICAL ROOM.
 - RECEPTACLES FED FROM PANEL LP-11 LOCATED IN MAIN ELECTRICAL ROOM.
 - ALL UNDERGROUND CONDUIT IS 1" UNLESS NOTED OTHERWISE.
- SHEET KEYNOTES:**
- FIXTURE TYPE S2: BOTTOM OF FIXTURE SHALL BE NO MORE THAN 1'-6" ABOVE GROUND. CONFIRM ARCHITECTURAL WALL DETAILS AND WALL HEIGHT WITH ARCHITECT PRIOR TO INSTALLATION. REFER TO ARCHITECTURAL DETAILS FOR FINAL FIXTURE LOCATIONS AND MOUNTING HEIGHT.
 - CONDUITS CONTINUED THROUGH BUILDING TO MDF.
 - CONDUITS STUBBED INTO GREEN SPACE FOR FUTURE USE.
 - CONDUIT AND WIRING CONTINUED THROUGH BUILDING TO MAIN ELECTRICAL ROOM.
 - POWER TO FIXTURES ROUTED THROUGH BUILDING.

REVISION 10/18/19 WESTPHAL
- New Sheet, Private Lighting within R/W

PROJECT NAME
UNIVERSITY
RESEARCH PARK /
INNOVATION ONE

PROJECT ADDRESS
5505 ENDEAVOR LANE
MADISON, WI 53719

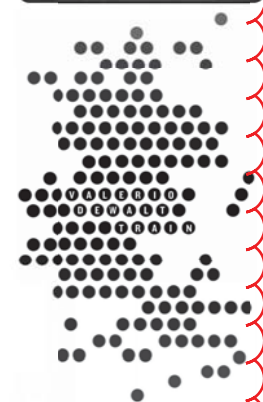

ARCHITECT
VALERIO DEWALT TRAIN ASSOCIATES, INC.
500 N. DEARBORN, 9TH FLOOR
CHICAGO, ILLINOIS 60654
312.260.7300
www.buildordie.com

PROJECT TEAM **ARCHITECT STAFF**

DAVID JENNERJAHN
BOB WEBBER
MATTHEW GAMACHE
VERONICA WIDHOLM
JOHN LUKE PRIFOGLIE

VDTA PROJECT NUMBER
17055.00

CONSULTANT

CONSULTANT PROJECT NUMBER

KEY PLAN

NO.	REVISION DESCRIPTION	DATE
1	DESIGN DEVELOPMENT	11/22/2017
2	SITE PLAN APPROVAL	11/27/2017
3	DESIGN DEVELOPMENT #2	07/18/2018
4	SITE PLAN APPROVAL-REVISED	03/02/2018
5	75% CONSTRUCTION DOCUMENTS	07/30/2018
6	100% CONSTRUCTION DOCUMENTS	08/29/2018
7	ISSUED FOR CONSTRUCTION	10/11/2018
8	MEPP BULLETIN #2	03/13/2019
9	ISSUED FOR CONSTRUCTION	04/26/2019
10	BCS BULLETIN #5	09/30/2019
11	CITY REVIEW SET	10/11/2019



© 2019 VALERIO DEWALT TRAIN ASSOCIATES, INC.

SHEET TITLE

ELECTRICAL SITE PLAN



SHEET NUMBER
ESO-01

TYPE	DESCRIPTION	MANUFACTURER	CATALOG NUMBER	MOUNTING	VOLTAGE	BALLAST/DRIVER TYPE	NO. OF LAMPS	WATTS	LAMP TYPE	LOCATION	REMARKS
S2	12" TALL EXTERIOR LED COLUMN LUMINAIRE. CUSTOM ETCHING DESIGN TO BE DETERMINED BY THE ARCHITECT.	LIGMAN LTD. TECHNILUM	LVA-200 VANCOUVER/CUSTOM ETCHING DESIGN-39-39K-FINISH TBD	MOUNTED WITHIN PLANTERS	277V	0-10V DIMMING DRIVER		39W	3900K LED	EXTERIOR PLAZA	

A B C D E F G H I J K L M

LANDSCAPING PLAN

ENDEAVOR LANE CITY OF MADISON

NOTES:

- CITY FORESTRY WILL ISSUE A REMOVAL PERMIT FOR 8 TREES TOTAL: 7 MEDIAN TREES DUE TO THE INSTALLATION OF A TURN LANE ON S. WHITNEY WAY AND ONE TREE ON S. WHITNEY WAY WITHIN THE TERRACE AREA OF ENDEAVOR LANE CONNECTION. PLEASE CONTACT BRAD HOFMANN BHOFMANN@CITYOFMADISON.COM OR 266-4816 TO OBTAIN THE STREET TREE REMOVAL PERMIT.

REVISION 10/18/19 AJZ
- Revised Tree Locations

TREE KEY:

- ⊖ CE = HACKBERRY
- ⊖ GT = SKYLINE HONEY LOCUST
- ⊖ GD = STREETKEEPER HONEY LOCUST
- ⊖ GB = PRINCETON SENTRY GINKGO
- X = TREE REMOVAL (WITHIN EX. R/W)

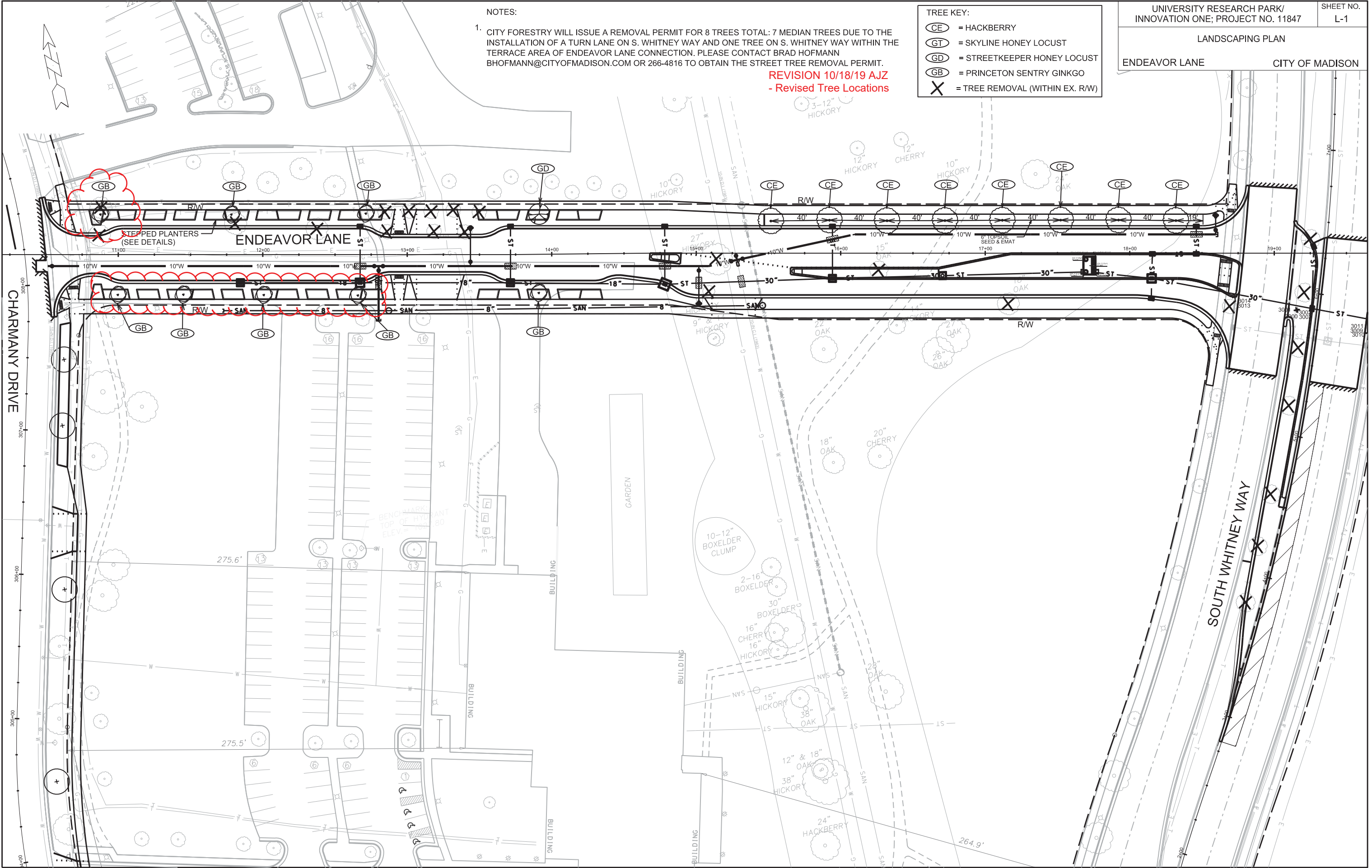

PLOT SCALE: _____

PLOT NAME: _____

REV. DATE: _____

ORIGINATOR: CITY OF MADISON, STREETS DIVISION

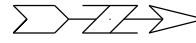

TREE KEY:

- (CE) = HACKBERRY
- (GT) = SKYLINE HONEY LOCUST
- (GD) = WHITE OAK
- (GB) = SENTINEL CRABAPPLE
- (X) = TREE REMOVAL (WITHIN EX. R/W)

PLOT SCALE: _____
 PLOT NAME: _____
 REV. DATE: _____
 ORIGINATOR: CITY OF MADISON, STREETS DIVISION

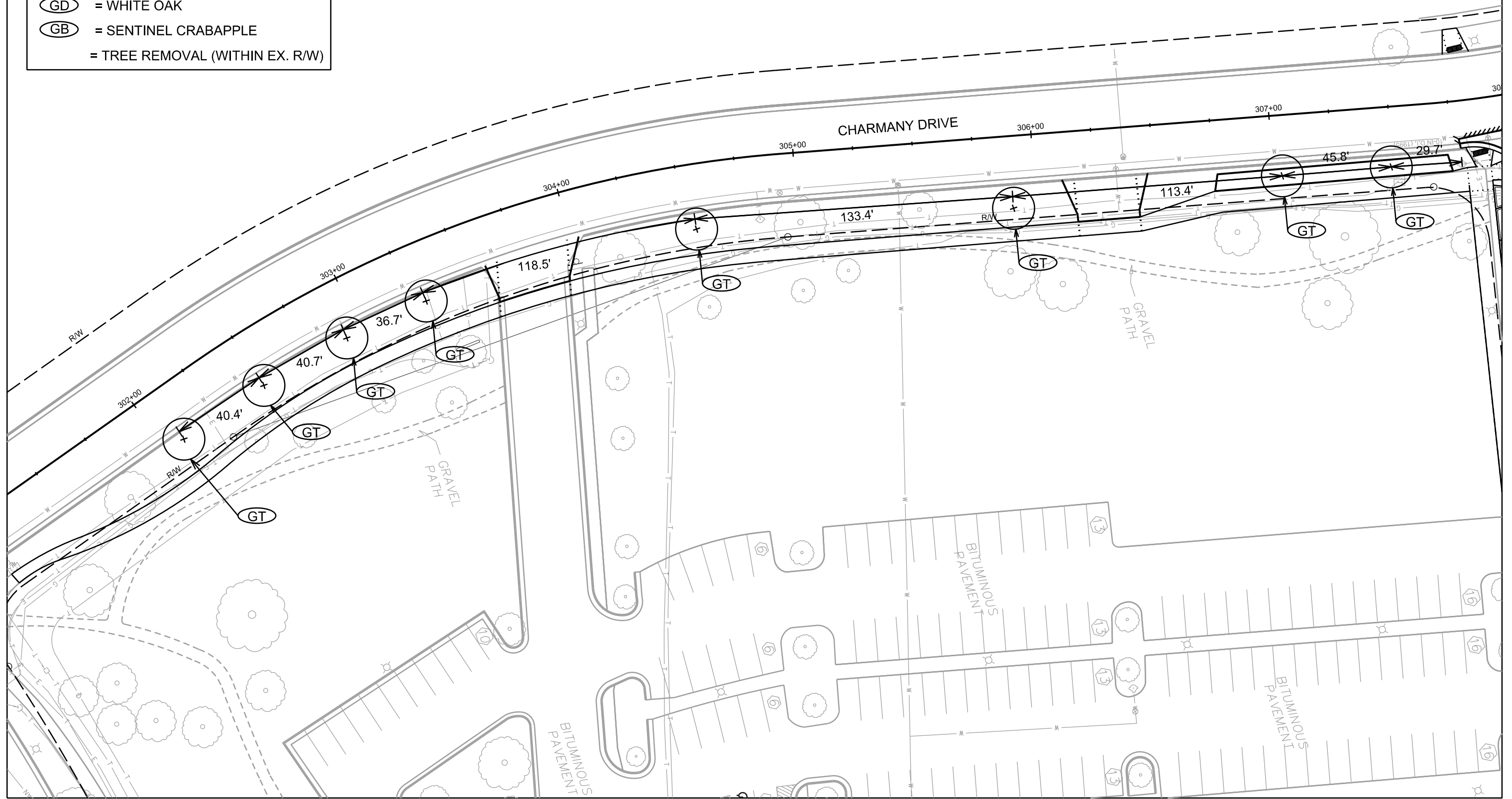



Callout	Description
1	Pavement Marking Epoxy, Stop Line, 24-Inch White
2	Pavement Marking Epoxy, Crosswalk, 6-Inch White
3	Pavement Marking Epoxy, Double Line, 4-Inch Solid Yellow
4	Pavement Marking Epoxy, Continental Crosswalk, 18-Inch White

PLOT SCALE: _____

PLOT NAME: _____

REV. DATE: _____

ORIGINATOR: CITY OF MADISON, TRAFFIC ENG. DIV.

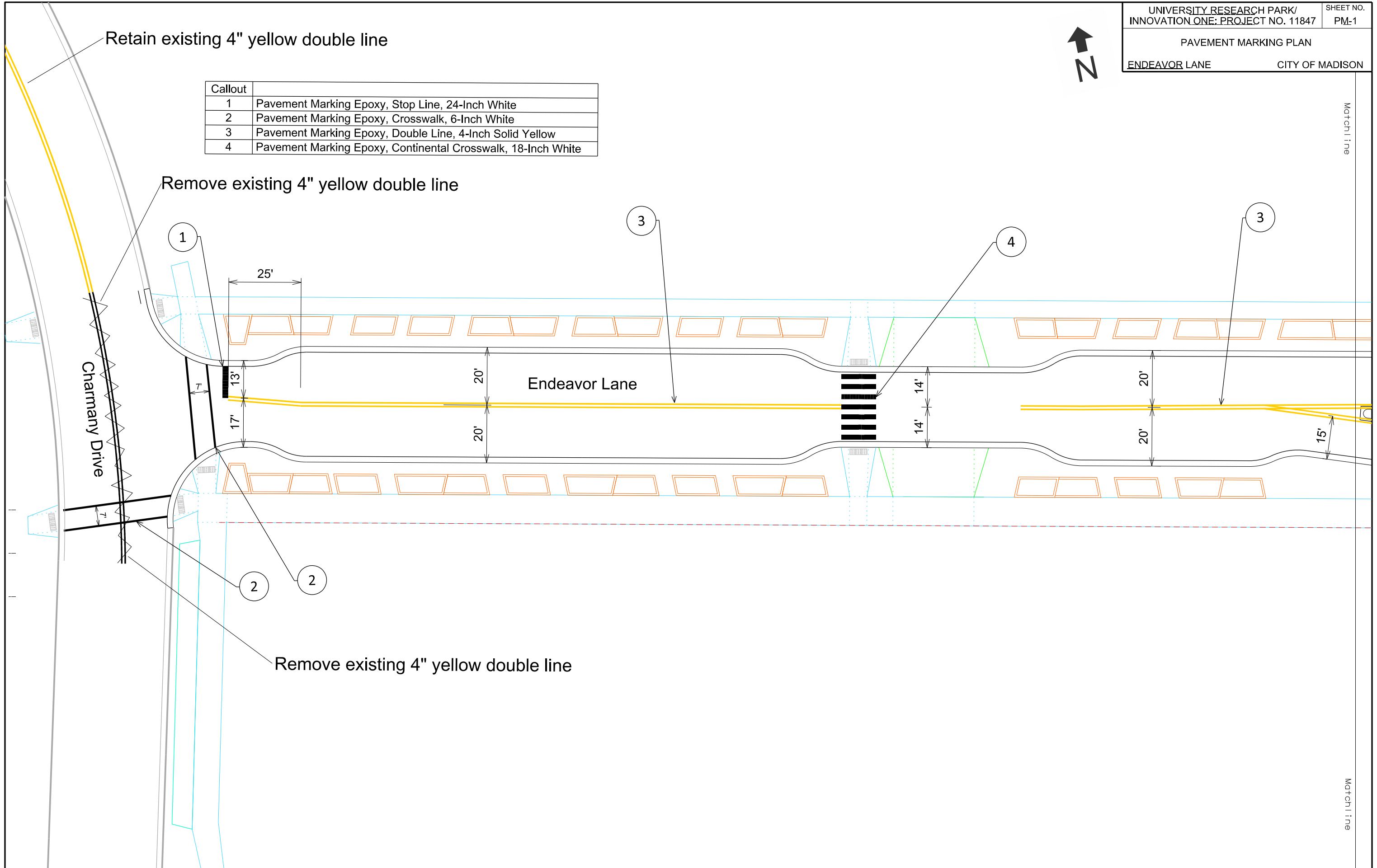



Callout	Description
1	Pavement Marking Epoxy, Stop Line, 24-Inch White
2	Pavement Marking Epoxy, Crosswalk, 6-Inch White
3	Pavement Marking Epoxy, Double Line, 4-Inch Solid Yellow
4	Pavement Marking Epoxy, Line, 8-Inch White

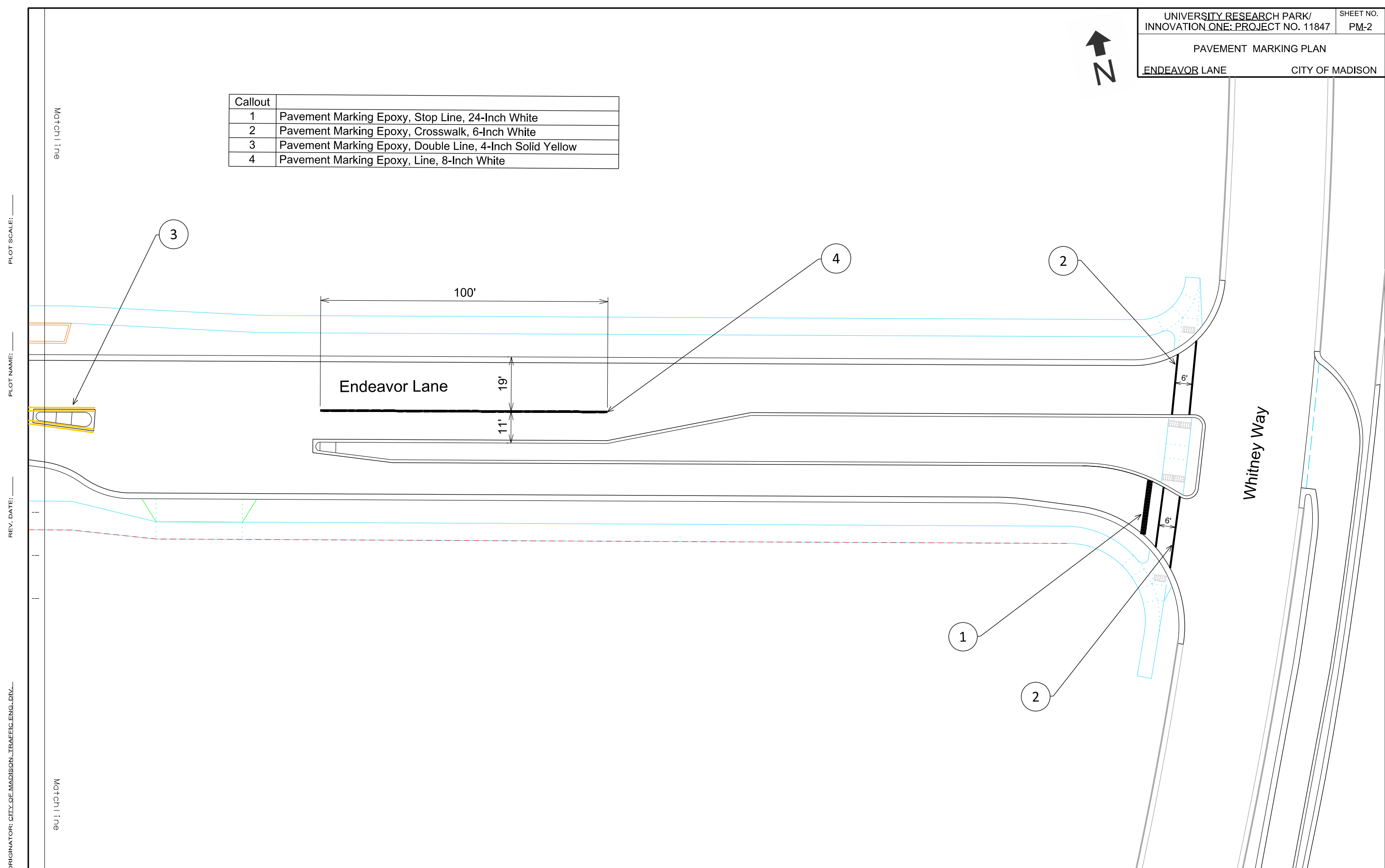

PLOT SCALE: _____

PLOT NAME: _____

REV. DATE: _____

ORIGINATOR: CITY OF MADISON, TRAFFIC ENG. DIV.