

PARKING LOT PLAN SITE INFORMATION

SITE ADDRESS: 444 GRAND CANYON DRIVE
 SITE ACREAGE (TOTAL): 3.2

NUMBER OF BUILDING STORIES (ABOVE GRADE): 1
 BUILDING HEIGHT: 19'-8"
 DILHR TYPE OF CONSTRUCTION: 6 (1988 CODE)
 TOTAL SQUARE FOOTAGE OF BUILDING: 14,551 SF

USE OF PROPERTY: BOWLING ALLEY - ASSEMBLY
 GROSS SQUARE FEET OF OFFICE: 569 SF
 GROSS SQUARE FEET OF RETAIL AREA: 548 SF
 NUMBER OF EMPLOYEES IN WAREHOUSE: NA
 NUMBER OF EMPLOYEES IN PRODUCTION AREA: NA
 CAPACITY OF RESTAURANT/PLACE OF ASSEMBLY: 1,319

NUMBER OF BICYCLE STALLS SHOWN: 20

NUMBER OF PARKING STALLS:

	SHOWN
SMALL CAR	0
LARGE CAR	197
ACCESSIBLE	7
TOTAL	203

NUMBERS OF TREES SHOWN: 22

GENERAL NOTES

1. XTG PARKING LOTS TREE AND SHRUBS SHOW ON THE SITE PLAN.
 FOR NEW PLANTINGS SEE THE LANDSCAPE PLAN.

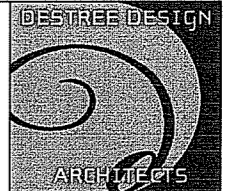
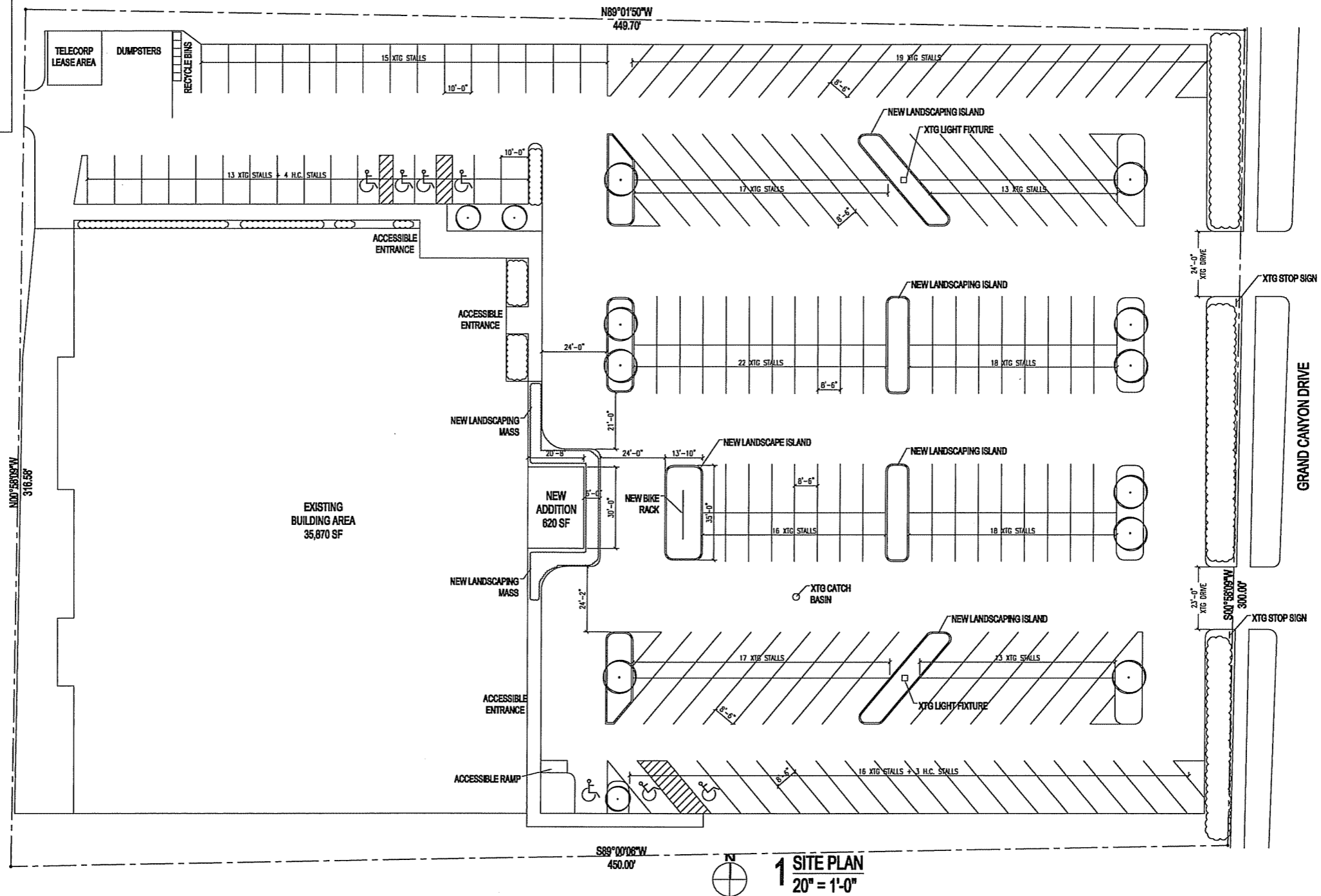

222 West Washington Ave.
 Suite 310
 Madison, WI 53703
 ph: 608.268.1499
 fax: 608.268.1498
 www.destreearchitects.com

DESTREE DESIGN ARCHITECTS HOLDS ALL RIGHTS INCLUDING THE COPYRIGHT OF THIS DOCUMENT, AS WELL AS THE CONCEPTS AND DESIGN, INCLUDING BUT NOT LIMITED TO THE CONCEPTS AND DESIGN, AND SHALL NOT BE REPRODUCED, DISTRIBUTED, OR USED IN WHOLE OR PART WITHOUT THE EXPRESS WRITTEN CONSENT OF DESTREE DESIGN ARCHITECTS.

**PARK TOWNE LANES
 BUILDING ADDITION**
 444 GRAND CANYON DR
 MADISON, WI 53719

ISSUANCES:

PROJECT:
 NUMBER: 061108.00
 DATE: 01.25.07
 REV:

SHEET:
CO.0

1 SITE PLAN
 20" = 1'-0"

EXISTING PLANT MATERIAL

QUANTITY	SPECIES	CATEGORY
9	ASH	CANOPY TREE
2	CRABAPPLE	SMALL TREE
60	CHOKEBERRY	DECIDUOUS SHRUB
7	YEW	EVERGREEN SHRUB
27	YEW	EVERGREEN SHRUB
5	SPREADING JUNIPER	EVERGREEN SHRUB

PROPOSED PLANT MATERIAL

QUANTITY	SPECIES	SCIENTIFIC NAME	SIZE
13	ASH	FRAXINUS AMERICANA	2.5"
3	MAPLE	ACER FREEMANTLI	2.5"
9	CRABAPPLE	MALUS NEGUNDA	2"
27	YEW	TAXUS MEDIA	18"
2	SPRUCE	PICEA GLAUCA	5"

LANDSCAPE WORKSHEET

Parking Lots, Storage Areas and Loading Areas
(Section 28.04 Madison General Ordinance)

Project Location/Address: 444 GRAND CANYON DR
 Name of Project: PARK TOWNE LANES-BUILDING ADDITION
 Owner/Contact: _____
 Address: _____

FOR PARKING LOTS WITH GREATER THAN 20 STALLS, LANDSCAPE PLANS MUST BE STAMPED BY A REGISTERED LANDSCAPE ARCHITECT

I. Number of Trees Required

The number of trees required for a parking lot is based on the number of parking stalls. Using the Schedule for Required Trees on the reverse side of this worksheet, determine the number of trees required. (Example: One tree is required for 10 parking stalls.)

Landscape requirements for storage areas are determined by dividing the total square footage of the storage area by (500) square feet. This converts area to stalls. (Example: 10,000 square feet is equivalent to (20) stalls or (2) trees and (100) points.

Number of Parking Stalls: 203

Total Square Footage of the Storage Area
Divided by Three Hundred (300) Square Feet: 0

Number of Canopy Shade Trees Required (2" - 2 1/2" Caliper)
(See Schedule on reverse side): 14

II. Number of Landscape Points Required

The number of points required is also based on the number of parking stalls. Using the Point Schedule for Landscape Elements on the reverse side of this worksheet, determine the number of points required. (Example: 49.5 points are required for 10 stalls). A point fraction of (.5) or less may be disregarded, while a fraction in excess of (.5) must be counted as one point. Thus, 49.5 points would be rounded down to 49.0 points required.

The number of points required for loading areas is (75) points for each loading berth. (See Schedule on reverse side.)

Number of Points Required (See Schedule on reverse side): 844

Total: 844

Tabulation of Points and Credits

Indicate below the quantity and points for all pertinent landscape elements. Also, credit information for boundary screening and any existing elements to be retained.

ELEMENT	POWER VALUE	QUANTITY	Credits	
			POINTS ACCRUED	POINTS
Canopy Trees 2" - 2 1/2"	15	14	210	150
Deciduous Shrub	2	27	54	54
Evergreen Shrub	3	27	81	54
Decorative Wall or Fence (per 10 L.F.)	5			
Earth Berm (per 10 L.F.)	5			
Avg. Height 30"	2			
Avg. Height 15"	15	2	30	
Evergreen Trees 3" height minimum	15	9	135	30
Canopy Tree or Small Tree 1 1/2" - 2" Caliper (i.e., Crab, Hawthorn)	15	9	135	30
Sub Totals			414	276
				TOTAL 844

Total No. of Points Provided (Equal to or greater than points required)

*Trees required in Part I above, are not to be included in the point count.



Approved by: _____ Date: _____

PARK TOWNE LANES
BUILDING ADDITION
444 GRAND CANYON DR
MADISON, WI 53719

LANDSCAPE PLAN
WATTS LANDSCAPE SERVICE

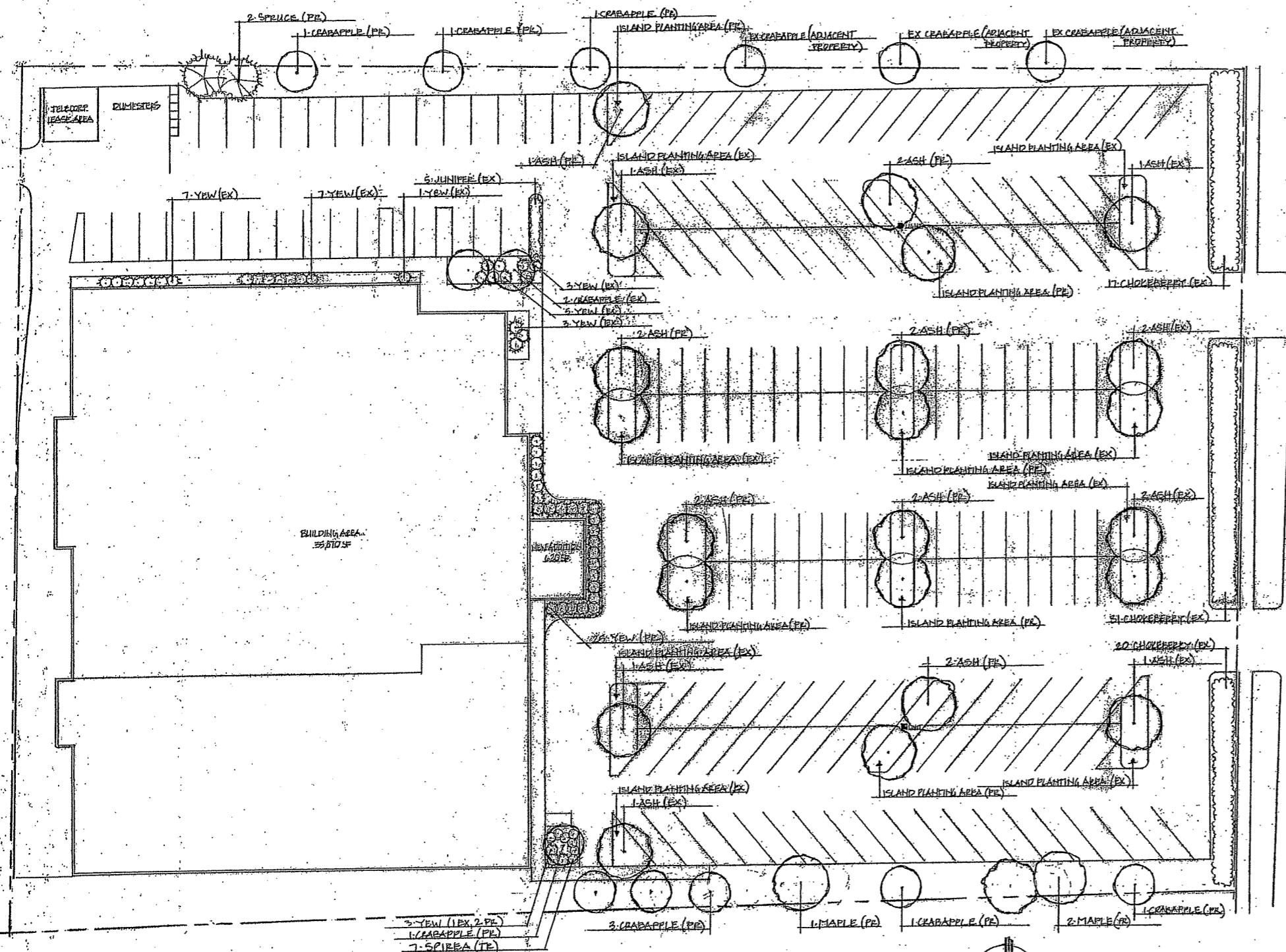

LEGEND
 EX EXISTING
 PR PROPOSED
 TR TRANSPLANTED

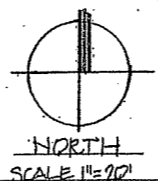

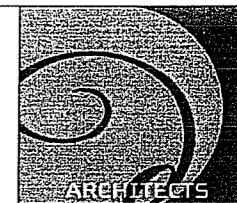

222 West Washington Ave.
Suite 310
Madison, WI 53703
ph: 608.268.1499
fax: 608.268.1498
www.destreearchitects.com

DESTREE DESIGN ARCHITECTS HOLDS ALL RIGHTS INCLUDING THE COPYRIGHT OF THIS DOCUMENT, AS WELL AS THE CONCEPTS AND DESIGNS INCORPORATED HEREIN AS AN INSTRUMENT OF SERVICE. AS PROPERTY OF DESTREE DESIGN ARCHITECTS IT IS NOT TO BE COPIED, DISTRIBUTED, OR USED IN WHOLE OR IN PART WITHOUT THE EXPRESS WRITTEN CONSENT OF DESTREE DESIGN ARCHITECTS.

**PARK TOWNE LANES
BUILDING ADDITION**
444 GRAND CANYON DR
MADISON, WI 53719

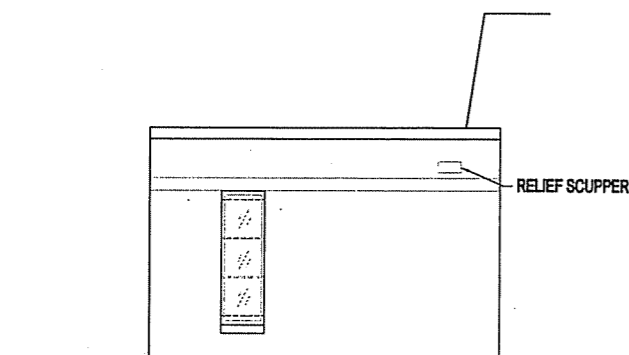

3 PARTIAL NORTH ELEVATION
1/8" = 1'-0"

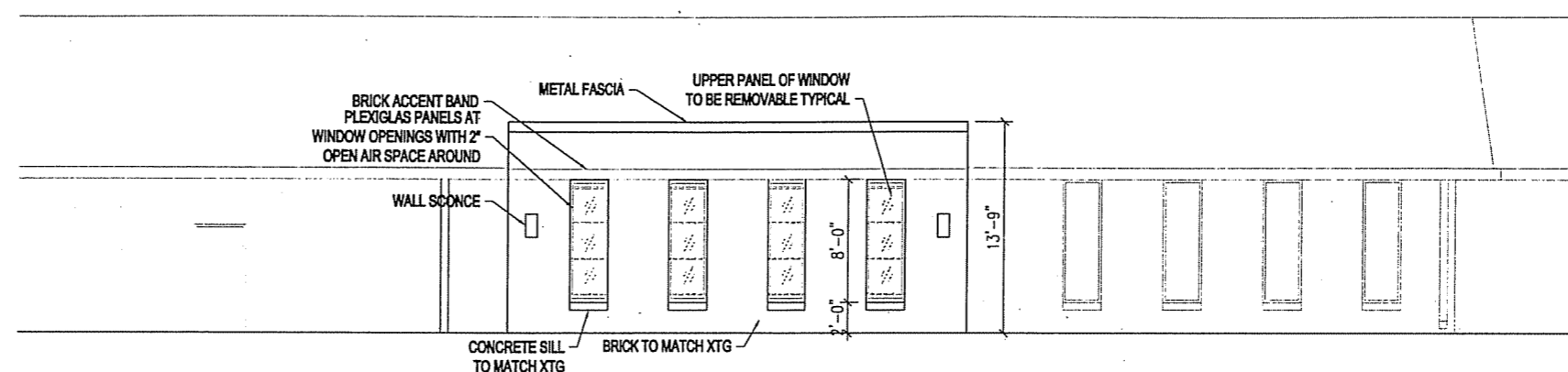

2 PARTIAL EAST ELEVATION
1/8" = 1'-0"

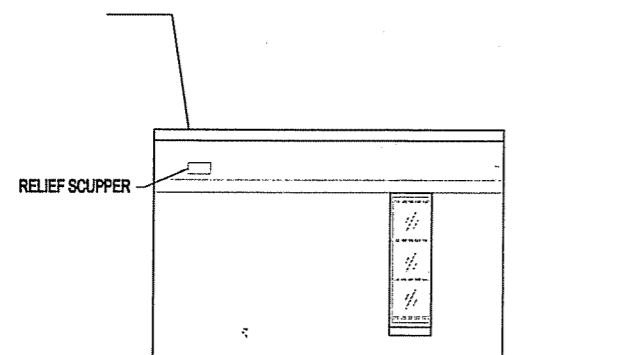

3 PARTIAL SOUTH ELEVATION
1/8" = 1'-0"

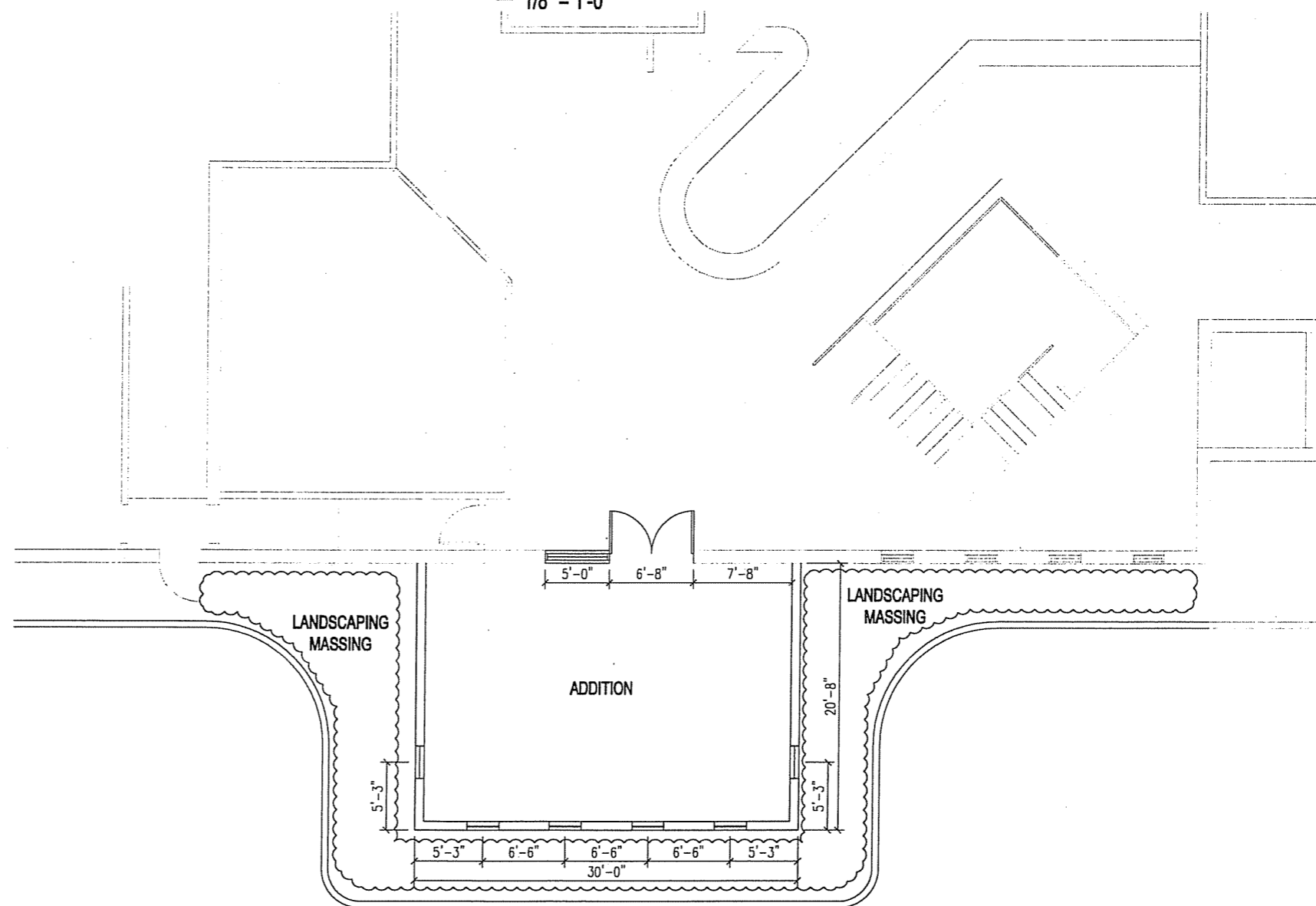

1 PARTIAL FLOOR PLAN
1/8" = 1'-0"

ISSUANCES:

PROJECT:

NUMBER: 061108.00

DATE: 01.25.07

REV:

SHEET:

A1.1