

---

## ##. General Regulations

## Introduction

*This section includes parking and landscaping standards, and several new sections: height and area exceptions, standards for telecommunications facilities, and environmental and performance standards that apply to all uses and sites. Parking standards are still being revised.*

## Parking and Loading Standards

### (1) Statement of Purpose

This section establishes minimum and maximum parking space ratios, and standards for the layout and design of parking spaces, lots and structures. It also includes shared parking incentives, and reduction of off-street parking in favor of transit or other travel modes. The standards in this section are intended to:

- A. Minimize the adverse effects of off-street parking and loading on adjacent properties.
- B. Minimize spillover on-street parking in neighborhoods.
- C. Encourage reduction of surface parking as a means of encouraging of transit, bicycle and pedestrian circulation.
- D. Encourage shared parking arrangements that will support mixed use development and compact development pattern.
- E. Provide adequate parking and storage space for bicycles.
- F. Encourage parking locations that do not disrupt Madison's traditional streetscape.

### (2) Number of Parking Spaces Required

Table \_\_\_ establishes the minimum number of parking spaces required, the maximum number of parking spaces permitted, and the minimum number of bicycle spaces required, for the uses indicated.

- A. No minimum parking. In the Central area, as defined, and the following districts, there is no specified minimum requirement for off-street parking of automobiles. Maximum parking requirements apply. Off-street parking for bicycles is required.
  - 1. Neighborhood Mixed Use (NMX) District
  - 2. Traditional Shopping Street (TSS) District
  - 3. Traditional Workplace (TW) District
- B. Parking waiver. For nonresidential uses, the first five (5) spaces required under "Minimum Parking" or the first ten percent (10%) of parking required, whichever is greater, may be waived.
- C. Where number of employees is used to determine parking, it shall be based on the number of employees on the maximum working shift at the time the occupancy permit is requested. Parking requirements based on number of employees will not change unless

new construction or expansion is proposed.

- D. Floor area calculation. Floor area used to calculate parking and loading requirements is defined as the sum of the gross horizontal areas of the floors or parts of a building devoted to the use, measured from the exterior faces of the exterior walls or from the center line of walls separating two buildings. It does not include porches, garages, or space in a basement or cellar when used for storage or incidental uses.
- E. Bicycle space minimum. A minimum number of two (2) bicycle spaces (the equivalent of one two-sided bike rack) is required for nonresidential uses.
- F. Computation. Fractional space requirements of up to one-half (½) space shall be rounded down to the next whole number and greater than one-half (½) rounded up to the next whole number.
- G. Parking requirements for persons with disabilities. The provisions contained in Sec. 101.12, 346.503, and Sec. 346.56 Wis. Stat. and any related Wisconsin Administrative Code sections are hereby adopted by reference and made applicable to all parking facilities whenever constructed.
- H. Unspecified uses. Where buildings are constructed without uses specified, the use with the highest parking requirement among all uses specified for the zoning district where the site is located shall be used to calculate off-street parking requirements.
- I. Unlisted uses. The zoning administrator shall establish the minimum and maximum parking and minimum loading required for any use not listed in Table \_\_. The zoning administrator may consider, but shall not be limited to, the following in establishing parking requirements for an unlisted use:
  1. Documentation. Documentation regarding the actual parking and loading demand for the proposed use.
  2. Evidence. Evidence in available planning and technical studies relating to the proposed use.
  3. Other jurisdictions. Required parking and loading for the proposed use as determined by other comparable jurisdictions.
  4. Estimation of similar uses. Examination of the parking and loading requirements for uses most similar to the proposed use.

**Table \_\_: Off-Street Parking Requirements**

Use	Minimum	Maximum	Bicycle
<b>Residential - Family Living</b>			
Single-family detached dwellings	1 per dwelling	-	-
Two-family dwelling – two-flat	1 per dwelling	2 per dwelling	-
Two-family dwelling - twin	1 per dwelling	2 per dwelling	-
Three-family dwelling	2 per 3 dwellings	2 per dwelling	-
Single-family attached dwelling	1 per dwelling	2 per dwelling	1 per dwelling

Use	Minimum	Maximum	Bicycle
Multi-family dwelling	.5 space per efficiency; .75 per 1-bedroom; 1 per other dwelling types	2.5 per dwelling	<u>1 per unit up to 2-bedrooms, ½ space per add'l bedroom; 1 guest space per 10 units</u>
Accessory dwelling	1 per dwelling	2 per dwelling	1 per dwelling
Manufactured home, mobile home	1 per dwelling	(see lot coverage)	1 per dwelling
Caretaker's dwelling	1 per dwelling or lodging room	2 per dwelling	1 per dwelling
<b>Residential - Group Living</b>			
Adult family home	1 per dwelling plus 1 per 3 rooms	150%	1 per dwelling
Community living arrangement	1 per dwelling plus 1 per 3 rooms	150%	1 per dwelling plus 1 per 3 rooms
Cohousing community	1 per dwelling; may be reduced by 20% with provision of community car or other shared vehicle for resident use	150%	1 per dwelling
Co-operative housing	1 per 4 bedrooms	1 per bedroom	1 per bedroom plus 1 guest space per 4 bedrooms units
Lodging house, rooming house	1 per 4 lodging rooms	1 per bedroom	1 per bedroom plus 1 guest space per 4 units
Dormitory, fraternity or sorority	1 per 4 lodging rooms	1 per bedroom	1 per bedroom plus 1 guest space per 4 units
Retirement home, assisted living, congregate care	1 space per 10 dwelling units or lodging rooms; 1 per 5 beds, plus 1 per 300 sq. ft. dining, kitchen and office area	1 per dwelling unit	1 per 4 units + 1 per 5 employees
Religious community	1 space per 6 bedrooms plus 1 per 300 sq. ft. dining, kitchen and office area	1 per bedroom	1 per bedroom
<b>Civic and Institutional Uses</b>			
Cemetery, mausoleum	as determined by zoning administrator	as determined by zoning administrator	as determined by zoning administrator
Day care, adult, child, nursery school	1 per 15 clients	200 % of minimum	1 per 5 employees
Library, museum	1 per 800 square feet floor area	1 per 400 square feet floor area	1 per 2,000 square feet floor area
Mission house in conjunction with religious institution	1 per 800 square feet floor area	1 per 400 square feet floor area	1 per 400 square feet floor area
Parks and playgrounds	none, except where required for specific facilities, as determined by zoning administrator		
Place of worship	1 per 10 seats or 15 lineal feet of seating area in the main worship space. If no fixed seats, 1 per 70 sq. ft. of floor area in main worship space	150% of minimum	1 per 50 seats or 75 lineal feet of seating area or 1 per 350 feet of floor area in main worship space

Use	Minimum	Maximum	Bicycle
Public safety facilities (fire, police stations, etc.)	as determined by zoning administrator	as determined by zoning administrator	as determined by zoning administrator
Schools, public and private	1 space per classroom + 1 space per 5 students of legal driving age based on the maximum number of students attending classes at any one time	1 space per classroom + 1 space per 3 students of legal driving age based on the maximum number of students attending classes at any one time	<u>1 space per 5 students</u>
Schools, arts, technical or trade	1 per classroom + 1 per 5 students of legal driving age based on the maximum number of students attending classes at any one time	1 per classroom + 1 per 3 students of legal driving age based on the maximum number of students attending classes at any one time	<u>1 space per 5 students</u>
Universities, colleges	1 per classroom and 1 per 5 students based on the maximum number of students attending classes at any one time; or as established in campus master plan	1 per classroom and + 1 per 3 students based on the maximum number of students attending classes at any one time; or as established in campus master plan	1 per classroom and <u>1 per 5 students</u> , or as established in campus master plan
<b>Mixed Commercial-Residential Uses</b>			
Live/work unit	1 per dwelling	2 total	1 per dwelling
Mixed commercial/residential use	calculated based on separate components (see shared parking standards)	calculated based on separate components (see shared parking standards)	calculated based on separate components (see shared parking standards)
<b>Commercial Uses</b>			
Offices	1 per 400 sq. ft. floor area	1 per 200 sq. ft. floor area	1 per 2,000 sq. ft. floor area
<u>Office, call center</u>	<u>1 per 2 employees</u>	<u>1 per employee</u>	<u>1 per 10 employees</u>
Artist, photographer studio, etc.	1 per 400 sq. ft. floor area	1 per 200 sq. ft. floor area	1 per 2,000 sq. ft. floor area
Insurance office, real estate office, sales office	1 per 400 sq. ft. floor area	1 per 200 sq. ft. floor area	1 per 2,000 sq. ft. floor area
<b>Medical Facilities</b>			
Clinic, medical, dental or optical	1 per 300 sq. ft. floor area	1 per 150 sq. ft. floor area	1 per 2,000 sq. ft. floor area
Hospital	1 per 4 beds or based on a parking study or campus master plan	as determined by zoning administrator	1 per 2,000 sq. ft. floor area
Medical laboratory	1 per 500 sq. ft. floor area	1 per 250 sq. ft. floor area	1 per 2,000 sq. ft. floor area
Physical, occupational or massage therapy	1 per 300 sq. ft. floor area	1 per 150 sq. ft. floor area	1 per 2,000 sq. ft. floor area
Veterinary clinic, animal hospital	1 per 300 sq. ft. floor area	1 per 150 sq. ft. floor area	1 per 2,000 sq. ft. floor area
<b>Retail Sales and Services</b>			
General retail	1 per 400 sq. ft. floor area	1 per 200 sq. ft. floor area	1 per 2,000 sq. ft. floor area

Use	Minimum	Maximum	Bicycle
Animal boarding facility, kennel	1 per 400 sq. ft. floor area	1 per 200 sq. ft. floor area	1 per 2,000 sq. ft. floor area
Bank, financial institution	1 per 300 sq. ft. floor area	1 per 150 sq. ft. floor area	1 per 2,000 sq. ft. floor area
<u>Building materials and home improvement retail center</u>	1 per 1,000 sq. ft. floor area + 1 per 1,000 sq. ft. of outdoor sales, display	1 per 500 sq. ft. floor area + 1 per 500 sq. ft. of outdoor sales, display	1 per 4,000 sq. ft. interior floor area
Business sales and services	1 per 400 sq. ft. floor area	1 per 200 sq. ft. floor area	1 per 2,000 sq. ft. floor area
Copy shop	1 per 400 sq. ft. floor area	1 per 200 sq. ft. floor area	1 per 2,000 sq. ft. floor area
Drive-through sales and services, primary and accessory	as determined by zoning administrator	as determined by zoning administrator	n/a
Dry cleaning, commercial laundry	1 per 500 sq. ft. floor area	1 per 250 sq. ft. floor area	1 per 4,000 sq. ft. floor area
Farmers' market	<u>none</u>	<u>as determined by zoning administrator</u>	as determined by zoning administrator
Food and related goods sales	1 per 400 sq. ft. floor area	1 per 200 sq. ft. floor area	1 per 2,000 sq. ft. floor area
Furniture and household goods sales	1 per 1,000 sq. ft. floor area	1 per 500 sq. ft. floor area	1 per 5,000 sq. ft. floor area
Garden center, outdoor Greenhouse, nursery	1 per 1,000 sq. ft. floor area + 1 per 1,000 sq. ft. of outdoor sales, display	1 per 500 sq. ft. floor area + 1 per 500 sq. ft. of outdoor sales, display	1 per 5,000 sq. ft. outdoor sales, display
Laundromat, self-service	1 per 400 sq. ft. floor area	1 per 200 sq. ft. floor area	1 per 2,000 sq. ft. floor area
Liquor store	1 per 400 sq. ft. floor area	1 per 200 sq. ft. floor area	1 per 2,000 sq. ft. floor area
Mortuary, funeral home	<u>1 per 200 square feet of assembly area</u>	<u>1 per 100 square feet of assembly area</u>	1 per 2,000 sq. ft. <u>assembly area</u>
Outdoor uses, commercial	1 per 1,000 sq. ft. of outdoor sales, display	1 per 500 sq. ft. of outdoor sales, display	1 per 5,000 sq. ft. outdoor sales, display
Package delivery service	1 per 400 sq. ft. floor area	1 per 200 sq. ft. floor area	1 per 2,000 sq. ft. floor area
Payday loan business	1 per 400 sq. ft. floor area	1 per 200 sq. ft. floor area	1 per 2,000 sq. ft. floor area
Pet daycare	1 per 400 sq. ft. floor area	1 per 200 sq. ft. floor area	1 per 5,000 sq. ft. floor area
Photocopying	1 per 400 sq. ft. floor area	1 per 200 sq. ft. floor area	1 per 2,000 sq. ft. floor area
Post office	1 per 300 sq. ft. floor area	1 per 150 sq. ft. floor area	1 per 2,000 sq. ft. floor area
Secondhand goods sales	1 per 400 sq. ft. floor area	1 per 200 sq. ft. floor area	1 per 2,000 sq. ft. floor area
Service business; service business with showroom or workshop	1 per 400 sq. ft. floor area	1 per 200 sq. ft. floor area	1 per 2,000 sq. ft. floor area
Small appliance repair; small engine repair	1 per 400 sq. ft. floor area	1 per 200 sq. ft. floor area	1 per 2,000 sq. ft. floor area

Use	Minimum	Maximum	Bicycle
<b>Food and Beverages</b>			
Catering	<u>1 per 2 employees</u>	<u>1 per employee</u>	<u>1 per 5 employees</u>
Coffee shop, tea house	<u>15%</u> of capacity of persons	<u>30%</u> of capacity of persons	5% of capacity of persons
Restaurant, carry-out, deli (no liquor sales), restaurant-tavern, tavern, brewpub	<u>20%</u> of capacity of persons	<u>40%</u> of capacity of persons	5% of capacity of persons
<b>Commercial Recreation, Entertainment and Lodging</b>			
Bed and breakfast establishment	1 per bedroom in addition to requirement for dwelling	<u>150% of minimum</u>	1 per 2 bedrooms
Health/sports club	10% of the capacity of persons	20% of the capacity of persons	5% of the capacity of persons
Hostel	1 per two bedrooms	1 per bedroom	1 per bedroom
Hotel, inn, motel	1 per bedroom	2 per bedroom	1 per 10 bedrooms
Indoor recreation	10% of the capacity of persons	20% of the capacity of persons	5% of the capacity of persons
Lodge, private club, reception hall	20% of the capacity of persons	40% of the capacity of persons	5% of the capacity of persons
Outdoor recreation (i.e., mini-golf, driving range, etc.)	<u>as determined by zoning administrator</u>	<u>as determined by zoning administrator</u>	<u>as determined by zoning administrator</u>
Theater, assembly hall, concert hall	20% of the capacity of persons in the auditorium	40% of the capacity of persons in the auditorium	5% of the capacity of persons in the auditorium
<b>Adult Entertainment</b>			
Adult use, adult entertainment tavern	30% of capacity in persons	60% of capacity	5% of capacity
<b>Automobile Services</b>			
Auto service station, body shop, repair station	1 per <u>2,000 sq. ft. of floor area</u> excluding service bays + 2 spaces per service bay	1 per <u>1,000 sq. ft. of floor area</u> excluding service bays + 2 spaces per service bay	<u>1 per 5 employees</u>
<u>Auto convenience market</u>	<u>1 per 1,000 sq. ft. of floor area</u>	<u>1 per 500 sq. ft. of floor area</u>	<u>1 per 1,000 sq. ft. floor area</u>
Auto sales and rental Note: rental vehicles on site may be stacked	1 per <u>1,000 sq. ft. floor area</u> + 2 spaces per service bay, if any	<u>1 per 500 sq. ft. floor area</u> + 4 spaces per service bay	<u>1 per 5 employees</u>
Automobile storage and towing (excluding wrecked or junked vehicles)	<u>1 per 500 sq. ft. floor area</u> + <u>1 per towing vehicle</u>	1 per 250 sq. ft. floor area + 1 per towing vehicle	<u>1 per 5 employees</u>
Car wash	<u>as determined by zoning administrator</u>	as determined by zoning administrator	<u>1 per 5 employees</u>
<b>Public Utility and Public Service Uses</b>			
Electric power production (principal use)	as determined by zoning administrator	as determined by zoning administrator	1 per 10 employees

Use	Minimum	Maximum	Bicycle
Electric substations, gas regulator stations, telecommunications facilities, sewerage system lift stations, water pumping stations and other public utility uses	as determined by conditional use approval	as determined by conditional use approval	-
<b>Transportation Uses</b>			
Bus or railroad passenger depot, railroad or intermodal freight yard, motor freight terminal, railroad yard or shop, taxi dispatching, maintenance and storage	1 per 2 employees	1 per employee	1 per 10 employees
<b>Limited Production, Processing and Storage</b>			
Artisan workshop	1 per 2 employees	1 per employee	1 per 5 employees
Bakery, wholesale	1 per 2 employees	1 per employee	1 per <u>5 employees</u>
Bottling plant	1 per 2 employees	1 per employee	1 per 10 employees
Contractor's yard	1 per 500 sq. ft. office or sales area + 1 per 3,000 sq. ft. storage area	1 per 250 sq. ft. office or sales area + 1 per 1,500 sq. ft. storage area	1 per 5,000 sq. ft. floor area
Laboratories - research, development and testing	1 per 500 sq. ft floor area	1 per 250 sq. ft	1 per 2,500 sq. ft. floor area
Limited production and processing	<u>1 per 1,000 sq. ft. floor area</u>	<u>1 per 500 sq. ft. floor area</u>	<u>1 per 5 employees</u>
Mail order house	1 per 2 employees	1 per employee	1 per 10 employees
Printing and publishing	1 per 2 employees	1 per employee	1 per 10 employees
Recycling collection center, drop-off station	1 per 2 employees	1 per employee	1 per 10 employees
Storage - personal indoor facility	<u>1 per 2 employees</u>	<u>1 per employee</u>	<u>1 per 10 employees</u>
<b>Industrial Uses</b>			
Light manufacturing	1 per 1,000 sq. ft. floor area up to 20,000 sq. ft. + 1 space per 2,000 sq. ft. in excess of 20,000 sq. ft. +1 per 5,000 sq. ft. outdoor storage	1 per 500 sq. ft. floor area + 1 per 1,000 sq. ft. in excess of 20,000 sq. ft. + 1 per 2,000 sq. ft. outdoor storage	1 per 10 employees
General manufacturing	1 per 1,000 sq. ft. floor area up to 20,000 sq. ft. + 1 space per 2,000 sq. ft. in excess of 20,000 sq. ft. +1 per 5,000 sq. ft. outdoor storage	1 per 500 sq. ft. floor area up to 20,000 sq. ft. + 1 space per 1,000 sq. ft. in excess of 20,000 sq. ft. +1 per 5,000 sq. ft. outdoor storage	1 per 10 employees
Asphalt, concrete batching or ready-mix plant	as determined by <u>zoning administrator</u>	as determined by <u>zoning administrator</u>	1 per 10 employees
Brewery	1 per 2 employees	1 per employee	1 per 10 employees
Concrete, asphalt and rock crushing facility	1 per 2 employees	1 per employee	1 per 10 employees
Extraction of gravel, sand, other raw materials	1 per 2 employees	1 per employee	1 per 10 employees
<u>Lumberyard</u>	<u>1 per 1,000 sq. ft. q. ft. floor area + 1 per 1,000 sq. ft. of outdoor sales, display</u>	<u>1 per 500 sq. ft. floor area + 1 per 500 sq. ft. of outdoor sales, display</u>	<u>1 per 10 employees</u>

Use	Minimum	Maximum	Bicycle
Motor vehicle salvage	1 per 2 employees	1 per employee	1 per 10 employees
Hazardous waste collection, storage or transfer	1 per 2 employees	1 per employee	1 per 10 employees
Recycling center	1 per 2 employees	1 per employee	1 per 10 employees
<b>Agricultural Uses</b>			
Cultivation	<u>1 per 5 employees</u>	<u>1 per employee</u>	<u>1 per 5 employees</u>
Animal husbandry	<u>1 per 5 employees</u>	<u>1 per employee</u>	<u>1 per 5 employees</u>
Intensive agriculture	as determined by <u>zoning administrator</u>	as determined by <u>zoning administrator</u>	<u>1 per 5 employees</u>
On-site agricultural retail, farm stand	as determined by <u>zoning administrator</u>	as determined by <u>zoning administrator</u>	as determined by <u>zoning administrator</u>

### (3) Adjustments to Minimum Number of Required Spaces

Where minimum parking is required, the following adjustments may be made, in addition to the parking waiver specified under Section (2)(B).

- A. Transit corridor reduction. Within six hundred (600) feet of a high-frequency transit corridor, as defined, the Plan Commission may authorize a reduction in minimum parking requirements of up to twenty-five percent (25%), depending on frequency of transit service and adequacy of pedestrian and bicycle linkages to transit stops or stations.
- B. Shared parking reduction. The zoning administrator may authorize a reduction in the minimum parking number of parking spaces required upon a determination that the hours of peak use among multiple uses will result in lower parking demand, using the method outlined in Subsection \_\_\_.
- C. Parking reduction request. A reduction in the minimum number of parking spaces required may be granted through the following procedures:
  1. A reduction of up to twenty (20) spaces may be approved by the zoning administrator.
  2. A reduction of more than twenty (20) spaces but less than twenty-five percent (25%) of the required parking may be approved by the Director.
  3. A reduction of more than twenty (20) spaces and twenty-five percent (25%) or more of the required parking must be reviewed by the Plan Commission as a conditional use.

A parking reduction request must be initiated by the owner, who must submit information to support the argument for reducing the required number of spaces.
- D. Bicycle parking reduction. The amount of bicycle parking required may be reduced under the following circumstances:

1. If more than fifty (50) bicycle parking spaces are required, the required spaces above fifty (50) may be reduced by one-half (1/2).
  2. If site constraints make it infeasible to provide sufficient bicycle parking on site, the required amount may be reduced or waived by the zoning administrator.
  3. If permission has been granted to locate required bicycle parking in the public right-of-way, those spaces may contribute to the minimum requirement.
  4. Public bicycle parking spaces within three hundred (300) feet may be counted toward compliance with required bicycle parking.
- E. Shared car reduction. A reduction in residential parking may be approved by the zoning administrator is a shared or community car is available on or within reasonable proximity of the site, for use by residents.
- F. Off-site parking. Parking for nonresidential uses may be reduced by one space for each space in a public parking lot or public parking structure located within one thousand three hundred twenty (1,320) feet of the use, as measured by using the shortest pedestrian route from the nearest corner of the parking lot or structure to the main public entrance of the use served.
- G. Deferral of required parking spaces. Any applicant may seek permission to defer installation of all or a portion of the required parking until such parking is needed; however, the site plan shall depict the minimum number of required parking spaces.
1. Single-family or two-family dwelling may defer construction of required parking and driveway until desired. Parking and driveway locations meeting all requirements must be shown on an approved site plan.
- H. Substitution by moped parking. Moped parking is not required. However, three (3) moped spaces may be substituted for one (1) required automobile parking space. Where provided, moped parking shall meet the standards in Sub. \_\_\_.
- I. Substitution by bicycle parking. Four (4) bicycle parking spaces above the minimum number required may be substituted for one (1) required automobile parking space.

#### **(4) Exceptions to Exceed Maximum Number of Spaces**

Parking exceeding the maximum may be allowed as a conditional use, provided that the additional parking is underground or enclosed and that the following factors are considered, in addition to the criteria of Section \_\_\_.

- A. Documentation regarding the actual parking demand for the proposed use.
- B. The impact of the proposed use on the parking and roadway facilities in the surrounding area.
- C. Whether the proposed use is located near a parking area that is available to the customers, occupants, employees and guests of the

proposed use.

- D. The availability of alternative forms of transportation and actions being taken by the applicant to enhance or promote those alternatives.
- E. Structured parking, rain gardens or other bioretention facilities, additional landscaping, pervious pavement, or other mitigation measures may be required as conditions for an exception.

## (5) Shared Parking Requirements

The zoning administrator may authorize a reduction in the total number of required parking spaces for two or more uses jointly providing off-street parking when their respective hours of peak operation do not overlap. Shared parking shall be subject to the location requirements of section \_\_\_ and the following conditions:

- A. Computation. The number of shared spaces for two or more distinguishable land uses shall be determined by the following procedure:
  1. Multiply the minimum parking required for each individual use, as set forth in Table \_\_\_, Specific Off-Street Parking Provisions, by the appropriate percentage indicated in Table \_\_\_ Shared Parking Calculations, for each of the six (6) designated time periods.
  2. Add the resulting sums for each of the six (6) columns.
  3. The minimum parking requirement shall be the highest sum among the six (6) columns resulting from the above calculations.
  4. Select the time period with the highest total parking requirement and use that total as the shared parking requirement.
- B. Other uses. If one or more of the land uses proposing to make use of shared parking facilities do not conform to the general land use classifications in Table \_\_\_, Shared Parking Calculations, as determined by the zoning administrator, the applicant shall submit sufficient data to indicate the principal operating hours of the uses. Based upon this information, the zoning administrator shall determine the appropriate shared parking requirement, if any, for such uses.
- C. Alternative procedure. An application may be submitted requesting that the zoning administrator authorize a greater reduction in the total number of required parking spaces for two (2) or more uses where an applicant believes that Table \_\_\_, Shared Parking Calculations, does not adequately account for circumstances unique to the particular property or properties in question.

The application shall include, at a minimum, a parking study with a detailed description of the proposed uses, their hours of operation, their anticipated peak parking demand, and anticipated hours that such peak parking demand would occur. Based upon this information, the zoning administrator may authorize a greater parking reduction than is authorized by Table \_\_\_, Shared Parking Calculations. The zoning administrator may impose reasonable

conditions to mitigate potential negative effects.

**Table\_\_ : Shared Parking Calculations**

General Land Use Classification	Weekdays			Weekends		
	2:00 a.m. -- 7:00 a.m.	7:00 a.m. -- 6:00 p.m.	6:00 p.m.-- 2:00 a.m.	2:00 a.m.-- 7:00 a.m.	7:00 a.m. -- 6:00 p.m.	6:00 p.m.-- 2:00 a.m.
Office/Warehouse/Industrial	5%	100%	5%	0%	10%	0%
Retail sales and services	0%	90%	80%	0%	100%	60%
Restaurant (not 24 hour)	10%	70%	100%	20%	70%	100%
Residential	100%	60%	100%	100%	75%	90%
Theater	0%	40%	90%	0%	80%	100%
Hotel: guest rooms (calculate conference and restaurant facilities separately)	100%	55%	100%	100%	55%	100%
Conference / Convention Facilities	0%	100%	100%	0%	100%	100%
Place of Worship	0%	25%	50%	0%	100%	50%
School, Grades K-12	0%	100%	25%	0%	30%	10%
Community Center, Library, Museum	0%	100%	80%	0%	100%	80%

- D. The shared parking spaces shall be maintained as long as the uses they serve are in operation.
- E. The required number of bicycle parking spaces will be provided.
- F. The property owner or owners shall sign and record, with the Dane county register of deeds, a written agreement in a form satisfactory to the city attorney, which states that there will be no substantial change in the use or occupancy of the property or properties that will increase the demand for parking in the shared parking facility. This agreement shall also include a statement that the property owner or owners and their tenants shall be provided access to, and use of, the shared parking facility. A copy of the agreement shall be filed with the Director.

## (6) Parking Design and Location

Parking for automobiles and other motor vehicles shall be designed according to the requirements of Section 10.08, Madison General Ordinances and the following standards.

- A. Surfacing. All parking lots and driveways shall have paved or approved surfaces, as required in Section 10.8, MGO. The use of permeable paving, as defined, is encouraged for all parking spaces provided above the minimum number required by this chapter.
  - 1. Residential drives serving single- to two-family dwellings may contain a grass center provided that the areas on which the vehicle's wheels touch are a minimum of twelve (12) to eighteen (18) inches in width.
- B. Snow removal. In winter months, required parking areas, including bicycle parking areas, shall be cleared of snow within a reasonable

time. Areas used for snow storage shall be approved by the zoning administrator.

C. Residential Parking Locations (see illustrations A, B,C).

1. Parking is not permitted within front yard setbacks, or any street side yard setback, including the side yard setback extension into the rear yard, except on a driveway meeting the standards of Section \_\_ below.
2. Parking shall not be located on street terraces, driveways, or any other areas located within a public right-of-way not explicitly designated by the Director of Public Works.
3. Parking spaces may be located within:
  - a. an interior side yard setback;
  - b. a rear yard setback, with a minimum separation of three (3) feet from a street right-of-way (on a corner or reversed corner lot);
  - d. within the building envelope.
4. Parking on a through lot. Through lots are defined as having two (2) front yards and no rear yard. Parking on a through lot may be located within the building envelope, or an interior side yard setback, but not in either front yard setback.
5. A maximum of forty percent (40%) of the front and rear yard setbacks may be paved and used for driveway and parking purposes. Lot coverage requirements also apply to residential lots.

D. Landscaping and Screening. All off-street parking areas shall be landscaped according to the standards of Section \_\_, with the exception of parking for single-family detached, two-family and three-family dwellings.

**(7) Residential Driveway Design and Location**

Driveways shall be designed according to the requirements of Section 10.08, Madison General Ordinances and the following standards.

- A. Driveways shall be a minimum of eight (8) feet in width, except where otherwise specified in Section 10.08.
- B. Driveways may be located in the following locations:
  1. Within a front yard setback or street side yard setback, including the extension of the side yard setback into the rear yard setback (see illustrations D and E). The driveway must lead only from a street to the nearest garage or to a paved or graveled parking area located in compliance with subsection .C above. Maximum driveway width is the width of the garage entrance or parking area, up to a maximum of twenty-two (22) feet.
  2. Within an interior side yard setback, leading to a garage or parking area located in compliance with subsection .C above (see illustration D). Maximum driveway width is ten (10) feet, which shall not be exceeded within the front yard

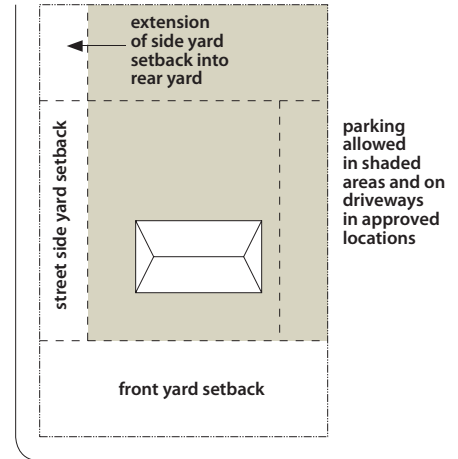

A. Parking locations on residential corner or reversed corner lot

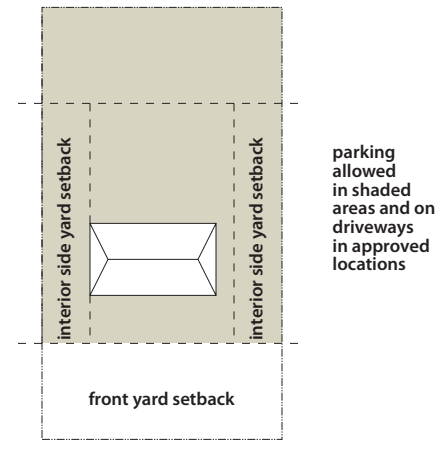

B. Parking locations on interior lot

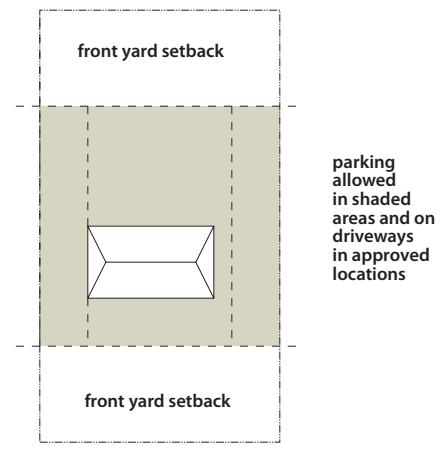

C. Parking locations on through lot

setback. No setback between the driveway and the side lot line is required.

D. Two driveways may be constructed within a front yard setback or, on a corner lot, within the street side yard setback, including the extension of the side yard setback into the rear yard setback, if the following standards are met (see illustration F):

1. Each driveway is a maximum of eleven (11) feet wide, or ten (10) feet within an interior side yard setback.
2. Both driveways meet at a point outside the required front, street side or side yard extension setbacks.
3. Both driveways lead to the same garage or to a paved or graveled parking area located in compliance with Subsection C above.

D. Two driveways may be constructed to serve twin dwellings (two-family dwellings separated by a common wall). Each dwelling may have one driveway that meets the requirement of Par. C. above, with a maximum width equal to the width of the garage entrance or parking area, not to exceed twenty-two (22) feet.

E. A maximum of two (2) curb cuts are permitted for any residential lot.

E. Driveways may be shared between two single- or two-family lots, provided that appropriate easements or other agreements are established. Shared driveways shall meet the minimum and maximum width requirements of this section.

F. Driveways shall be oriented in a perpendicular fashion to the street from which they take access, and shall cross required setbacks in a perpendicular fashion, to the extent feasible.

G. Driveways serving commercial or industrial uses shall not cross residentially-zoned properties, except where allowed by conditional use.

**(8) Restrictions on Residential Parking**

A. A maximum of one (1) commercial vehicle per dwelling unit may be parked outdoors on residential property if the vehicle is:

1. Used by a resident of the dwelling unit;
2. Has a manufacturer's gross vehicle weight rating of ten thousand (10,000) pounds or less and is less than twenty-one (21) feet in length.

B. Vehicles and/or equipment not normally associated with a residential use are specifically prohibited from being parked or stored outdoors on residential property. Such vehicles include, but are not limited to:

1. Construction equipment, such as bulldozers, backhoes, skid steers, and fork lifts
2. Dump and stake body style trucks
3. Cube type vans and trucks
4. Landscaping business equipment such as tractors, tree

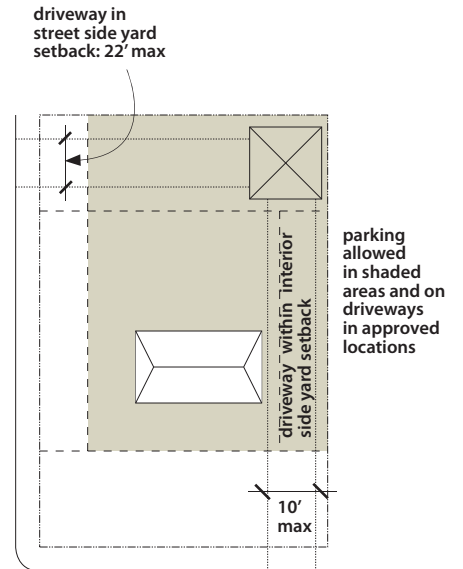

D. Interior and street side yard driveway examples; detached garage

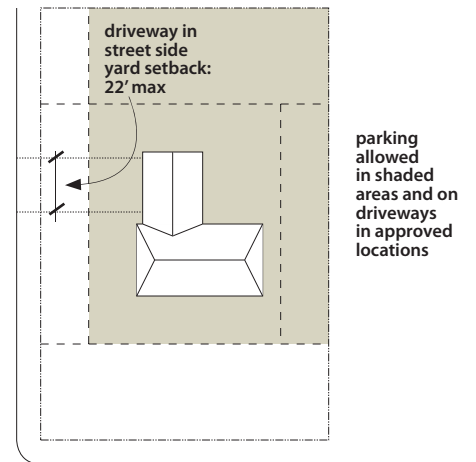

E. Street side yard driveway example; attached garage

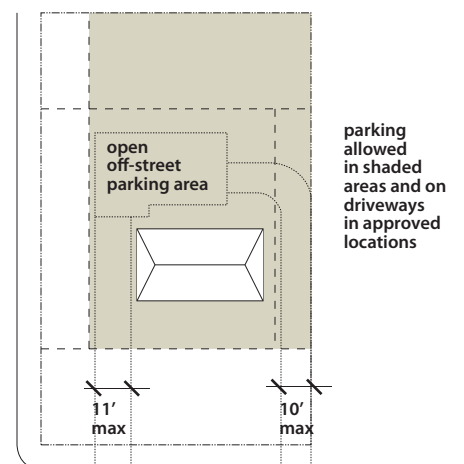

F. Two driveways on a residential lot

- spades, graders and scrapers
  - 5. Semi-trailers and tractors
  - 6. Concession, vending and catering trailers
  - 7. Commercial/Industrial equipment trailers and lifts
  - 8. Tow trucks, wreckers or car carriers
- C. A recreational vehicle (RV) associated with residential uses may be parked as a passenger vehicle but shall not be utilized for living space or storage of goods, materials or equipment other than is considered part of the RV or essential to its function.
- D. All vehicles parked on a residential lot shall display current license plates and be in safe, functional and operable condition.

### **(9) Bicycle Parking Design and Location**

- A. Parking designation. Bicycle parking requirements are as shown in Table \_\_, and shall be designated as long-term or short-term parking.
- 1. For all residential uses, including those in combination with other uses, at least ninety percent (90%) of resident bicycle parking shall be designed as long-term parking. Any guest parking shall be designed as short-term parking.
  - 2. For all other uses, at least fifty (50) percent of all bicycle parking shall be designed as short-term parking.
- B. Required short-term bicycle parking spaces shall be located in a convenient and visible area within fifty (50) feet of a principal entrance and shall permit the locking of the bicycle frame and one (1) wheel to the rack and shall support a bicycle in a stable position.
- C. Required long-term bicycle parking spaces shall be located in enclosed and secured or supervised areas providing protection from theft, vandalism and weather and shall be accessible to intended users. Required long-term bicycle parking for residential uses shall not be located within dwelling units or within deck or patio areas accessory to dwelling units. With permission of the zoning administrator, long-term bicycle parking spaces for non-residential uses may be located off-site within three hundred (300) feet of the site.
- D. Bicycle parking spaces shall be two and one-half (2½) by six (6) feet in size. Each required bicycle parking space must be accessible without moving another bicycle and its placement shall not result in a bicycle obstructing a required walkway. Bicycle racks shall be installed to the manufacturer's specifications, including the minimum recommended distance from other structures.

### **(10) Moped Parking Design and Location**

Where moped or scooter off-street parking is provided, it shall meet the following standards:

- A. Spaces shall be three (3) feet by six (6) feet in size with a vertical clearance of six (6) feet and with a drive aisle of five (5) to six (6) feet.

- B. The spaces may be located close to bicycle parking areas but kept separate and out of the way of conflict with other motor vehicle traffic. Moped parking shall not be located within front yard setback areas.
- C. Spaces shall be located and access should be provided such that the use or crossing of pedestrian facilities, including wheelchair ramps, by mopeds is discouraged and such that mopeds do not come into conflict with pedestrians or the users of wheelchairs.
- D. Access to moped areas should be provided using a separate driveway via a curb cut and ramp or mountable curb with a reduced slope after taking into account traffic movements on the street from which safe access must be provided.
- E. Moped driveways may cross a sidewalk as may any driveway but must not use the sidewalk to provide access to moped stalls. Moped parking areas behind a sidewalk should be separated by a curb when possible.

**(11) Off-Street Loading Requirements**

Any use which has a gross floor area of ten thousand (10,000) square feet or more, and which requires deliveries or makes shipments, shall provide off-street loading facilities in accordance with the regulations of this Section.

- A. Location. All loading berths shall be located twenty-five (25) feet or more from the intersection of two street right-of-way lines. Loading berths shall not be located within any required front yard or street side yard setback area. All loading areas shall be located on private property and shall not be located within, or interfere with, any public right-of-way.
- B. Required number of spaces are based on the size of the establishment as follows:

Size of establishment	Number of loading spaces
Office buildings and lodging:	
10,000 to 50,000 sq. ft. GFA	1 loading space
50,001 to 200,000 sq. ft. GFA	2 loading spaces
over 200,000 sq. ft. GFA	2 + 1 additional space per each 75,000 sq. ft. GFA above 200,000
Retail, service, commercial, wholesale and industrial uses	
10,000 to 20,000 sq. ft. GFA	1 loading space
20,001 to 100,000 sq. ft. GFA	2 loading spaces
over 100,000 sq. ft. GFA	2 + 1 additional space per each 75,000 sq. ft. GFA above 100,000

- C. Size of spaces. A required off-street loading space shall be at least ten (10) feet wide by at least thirty-five (35) feet in length for structures less than twenty thousand (20,000) square feet in gross floor area, and at least ten (10) feet wide by fifty (50) feet in length for larger structures. The above areas shall be exclusive of aisle and maneuvering space, and shall have a vertical clearance of at least fourteen (14) feet.

- D. Shared loading. Two or more uses on adjacent zoning lots may share a loading area.
- E. Uses for which off-street facilities are otherwise required but which are located in structures of less than twenty thousand (20,000) square feet of floor area may use drive aisles or other suitable areas on the same lot for loading purposes.
- E. Surfacing. All open off-street loading areas shall be paved with a bituminous pavement or Portland cement concrete pavement in accordance with City of Madison standards and specifications.

## Landscaping and Screening Requirements

### (1) Statement of Purpose

The landscaping and screening requirements specified in this section are intended to:

- A. Foster aesthetically pleasing development which will protect and enhance the appearance, character, health, safety and welfare of the community.
- B. Increase the compatibility of adjacent uses, by minimizing adverse impacts of noise, dust and other debris, motor vehicle headlight glare or other artificial light intrusions and other objectionable views, activities or impacts to adjacent or surrounding uses.

### (2) Applicability

The following standards apply to all exterior construction and development activity, including the expansion of existing buildings, structures and parking lots, except the construction of detached single-family and two-family dwellings and their accessory structures.

### (3) Landscape Plan Required

Landscape plans shall be submitted as a component of a site plan, where required, or as a component of applications for other actions, including zoning permits, where applicable. Landscape plans for zoning lots greater than ten thousand (10,000) square feet in size must be prepared by a registered landscape architect. Elements of the landscape plan are listed in Appendix \_\_, Submittal Checklists.

### (4) Vision Clearance at Corners

In order to provide a clear view of intersecting streets to motorists, a triangular area of clear vision formed by the two intersecting streets and driveways and a line connecting said centerlines, shall be kept clear of visual obstruction, as specified below.

- A. Where two streets intersect, the line shall extend a minimum of twenty-five (25) feet from the intersection of the two street property lines.
- B. At the intersection of a private drive or alley with a street, the line shall extend a minimum of ten (10) feet from the intersection of the street and alley or drive property lines.

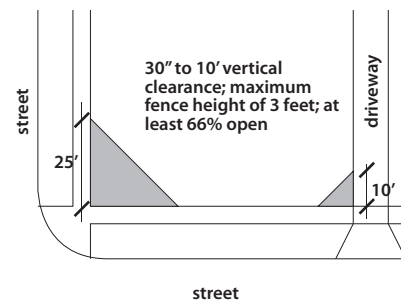

Vision clearance triangles for street and driveway

- C. At the intersection of any railroad crossing with a street or highway, a vision clearance triangle with a minimum dimension of three hundred thirty (330) feet shall be maintained.
- D. Within any vision clearance triangle, screening, planting, walls, fences or other obstructions are not permitted between a height of thirty (30) inches and ten (10) feet above the curb level, with the exception of fences a maximum of three (3) feet in height and at least two-thirds (2/3) open to vision.
- E. Dimensions of the vision clearance triangle may be reduced based on the recommendation of the Traffic Engineering Division.

**(5) Landscape Calculations**

Required landscaped areas shall be calculated based upon the total developed area of the property. Developed area, for the purpose of this requirement, is defined as all parts of the site that are not left in a natural state within a single contiguous boundary, including building footprints, parking and loading areas, driveways, internal sidewalks, patios, and outdoor activity areas. Developed area does not include other land within required setbacks and natural areas on the same property that are left undisturbed.

- A. One (1) landscape unit shall be provided for each three hundred (300) square feet of developed area, with the exception of the IL and the IG districts as specified in B. below.
- B. Within the Industrial - Limited and Industrial - General districts, one (1) landscape unit shall be provided for every one thousand two hundred (1,200) square feet of developed area.
- C. One landscape unit consists of five (5) landscape points. Landscape points are calculated as shown in the following table.

Plant type	Points	Minimum Size at Installation
Overstory deciduous tree	35	2 inch caliper
Ornamental tree	15	1 1/2 inch caliper
Evergreen tree	15	4 feet tall
Shrub, deciduous	2	5 gallon container size
Shrub, evergreen	3	5 gallon container size

- D. Calculations yielding a fraction up to one-half (1/2 or 0.5) shall be rounded down to the nearest whole number; fractions of more than one half (1/2) shall be rounded up.
- E. Landscaping shall be distributed as throughout the property along parking lot frontages, within parking lot interiors, and as foundation plantings as specified in subsections (6) through (8) below, or as general site landscaping.
- F. Planting beds or planted areas must have at least seventy-five percent (75%) vegetative cover. Non-planted areas shall not be paved, but shall be covered with a weed barrier and mulched.
- G. Additional landscaping requirements may be specified by the Plan Commission for conditional uses.

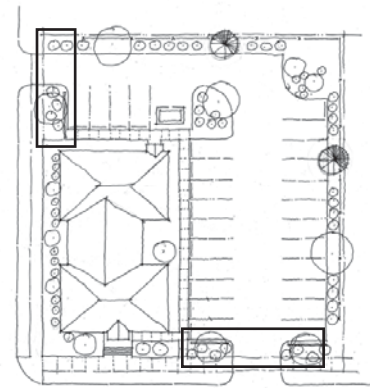

Parking Lot Frontage Landscaping

**(6) Parking Lot Frontage Landscaping**

Where off-street parking abuts a street or pedestrian walkway or trail, a landscaped area between the lot line and the paved surface of the parking lot is required. Landscape material shall include a mix of trees, shrubs and groundcover, meeting the following requirements:

- A. One (1) overstory deciduous tree and five (5) shrubs shall be planted for each thirty (30) lineal feet of parking lot frontage. Two (2) ornamental trees or two (2) evergreen trees may be used in place of one (1) overstory deciduous tree.
- B. In cases where parking lot landscaping cannot be provided due to site constraints, the zoning administrator may waive the requirement or substitute alternative screening methods for the required landscaping.

**(7) Parking Lot Interior Landscaping**

The purpose of interior parking lot landscaping is to improve the appearance of parking lots, provide shade, and improve stormwater infiltration. All parking lots with twenty (20) or more parking spaces shall be landscaped in accordance with the following interior parking lot standards.

- A. A minimum of five percent (5%) of the asphalt or concrete area of the parking lot shall be devoted to interior planting islands. The planting islands shall contain a minimum of one hundred sixty (160) square feet and be a minimum of seven (7) feet in width.
- B. The primary plant materials shall be shade trees with at least one (1) deciduous canopy tree for every one hundred sixty (160) square feet of landscaped area. Two (2) ornamental or evergreen trees may be substituted for one (1) canopy tree. Islands shall include shrubs, sod, or other vegetative ground cover between required trees.
- C. Islands may be curbed or may be designed as uncurbed bio-retention areas as part of an approved low impact stormwater management design approved by the Director of Public Works. The ability to maintain these areas over time must be demonstrated. [will need to cross-reference to Article 37, Erosion and Stormwater Runoff Control].

**(8) Foundation Plantings**

Foundation plantings consist primarily of shrubs, and shall be installed along building facades, except where building facades directly abut the sidewalk (a zero setback).

**(9) Screening along District Boundaries**

Screening shall be provided along side and rear property boundaries between commercial, mixed use or industrial districts and residential districts. Screening shall consist of a solid wall, solid fence, or hedge with year-round foliage, between six (6) and eight (8) feet in height, except that within the front yard setback area, screening or fencing shall not exceed four (4) feet in height.

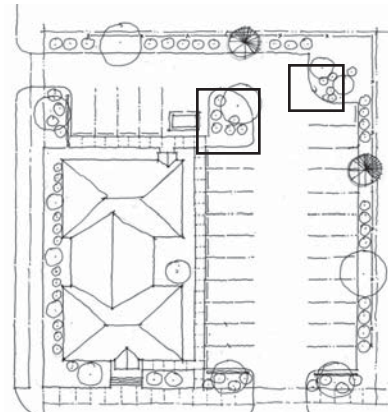

Parking Lot Interior Landscaping

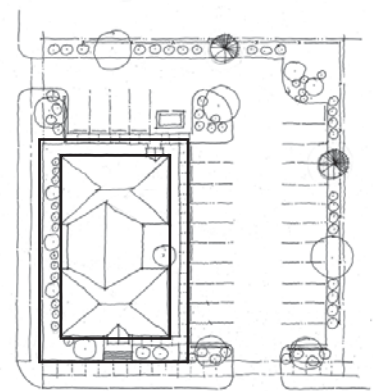

Foundation Plantings

## (10) Screening of Other Site Elements

The following site elements shall be screened as follows:

- A. Refuse disposal areas. All developments, except single family and two family developments, shall provide a refuse disposal area. Such area shall be screened on four (4) sides (including a gate for access) by a solid, commercial-grade wood fence, wall, or equivalent material with a minimum height of six (6) feet and not greater than seven (7) feet.
- B. Outdoor storage areas. Outdoor storage areas shall be screened from abutting residential uses with a by a building wall or solid, commercial-grade wood fence, wall, year-round hedge, or equivalent material, with a minimum height of six (6) feet and not greater than seven (7) feet. Screening along district boundaries, where present, may provide all or part of the required screening
- C. Loading areas. Loading areas shall be screened from abutting residential uses and from street view to the extent feasible by a building wall or solid, commercial-grade wood fence, or equivalent material, with a minimum height of six (6) feet and not greater than seven (7) feet. Screening along district boundaries, where present, may provide all or part of the required screening.
- D. Mechanical equipment. All rooftop and ground level mechanical equipment and utilities shall be fully screened from view from any street or residential district, as viewed from six (6) feet above ground level. Screening may consist of a building wall or fence and/or landscaping as approved by the zoning administrator.

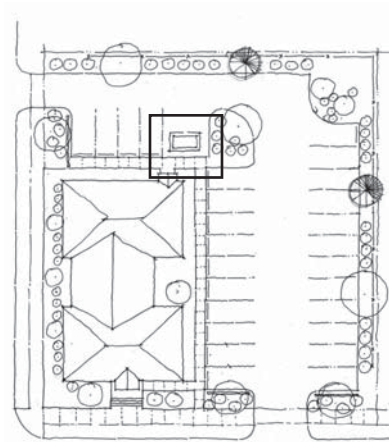

Screening of Other Site Elements

## (11) Design Standards for Landscape Material

- A. Plant selection. Plant materials provided in conformance with the provisions of this section shall be of nursery quality and capable of withstanding the extremes of individual site microclimates. Preferred and prohibited plant materials are listed in Appendix \_\_ *[TBA]*
- B. Overall composition and location of landscaped areas shall complement the scale of the development and its surroundings. In general, larger, well-placed contiguous planting areas shall be preferred to smaller, disconnected areas.

## (12) Maintenance

The owner of the premises is responsible for the watering, maintenance, repair and replacement of all landscaping, fences, and other landscape architectural features on the site. All planting beds shall be kept weed free. Plant material that has died shall be replaced within twelve (12) months.

## (13) Fences, Walls and Hedges

Fences, walls and hedges ~~used for screening~~ may be erected, placed, or maintained in any yard along or adjacent to a lot line in accordance with the requirements identified in this section. The owner shall be responsible for properly locating all property lines before construction of any fence.

- A. Height in residential districts.

1. The maximum height of a fence or hedge within required side and rear setbacks in a residential zoning district shall not exceed six (6) feet. A fence of up to eight (8) feet in height may be constructed on a district boundary line between a residential district and a mixed-use, commercial or employment district.
  2. Fences around pools shall not exceed eight (8) feet.
  3. The maximum height of a solid fence or hedge within a required front or corner side yard setback shall not exceed four (4) feet, except that a fence or hedge of up to six (6) feet may be located within a corner side yard setback behind the rear plane of the principal building. Solid fences exceeding four (4) feet in height shall be set back a minimum of four (4) feet from the sidewalk.
    - a. Such front yard or corner side yard fences may be increased to a maximum height of five (5) feet if open, decorative, ornamental fencing materials that are less than fifty (50) percent opaque are used or to a maximum height of six (6) feet if open, decorative, ornamental fencing materials that are less than twenty (20) percent opaque are used.
- B. Height in mixed use or nonresidential zoning districts. The maximum height of a fence or wall shall not exceed eight (8) feet except in required front or corner side yard setbacks where the maximum height of a solid fence or wall shall not exceed three (3) feet.
- C. Height measurement. In the case of grade separation, such as the division of properties by a retaining wall, fence height shall be determined based on measurement from the average point between highest and lowest grade. If the fence is set back from the retaining wall by a distance of at least four (4) feet, the fence height shall be measured from the base of the fence.
- D. Fences or walls shall comply with the vision clearance triangle requirements of Subsection \_\_.
- E. Fences and walls located in the front or street side yard setback areas must be made of materials such as wood, ornamental metal, brick, vinyl-coated chain link or stone. Uncoated chain link fences may be used in interior side or rear yards.
- F. Temporary fencing, including the use of wood or plastic snow fences for the purposes of limiting snow drifting between November 1 and April 1, protection of excavation and construction sites, and the protection of plants during grading and construction is permitted for a time period consistent with an approved building permit or up to one hundred eighty (180) consecutive days per calendar year.

*Fence Definition: An enclosure or barrier, such as wooden posts, wire, iron, or other manufactured material or combination of materials erected to enclose, screen or separate areas.*

## Exceptions to Height and Bulk Limits

### (1) Height Limit Exceptions

The following structures are permitted to exceed the maximum height regulations within any district where permitted: church spires, belfries, cupolas and domes, water towers, flagpoles, chimneys, communication towers

and elevator penthouses. Communications towers within residential districts shall not exceed a maximum height of seventy-five (75) feet above grade. All structures shall comply with the provisions of subsection (2) below.

## (2) Capitol View Preservation

No portion of any building or structure located within one mile of the center of the State Capitol Building shall exceed the elevation of the base of the columns of said Capitol Building or one hundred eighty-seven and two-tenths (187.2) feet, City datum. Provided, however, this prohibition shall not apply to any church spires, flagpoles, communication towers (except communication towers in residential districts, which shall comply with the requirements of Section (1) above), elevator penthouses, screened air conditioning equipment on existing buildings and chimneys exceeding such elevation, when approved as conditional uses. For the purpose of this subsection, City datum zero (0.00) feet shall be established as eight hundred forty-five and six-tenths (845.6) feet above sea level as established by the United States Coast and Geodetic Survey.

*Capitol view height limits will likely be integrated into the Downtown districts as well as appearing here.*

## (3) Public Utility Exemptions

- A. The following public utility uses, which are essential in most districts, shall be permitted in any zoning district: poles, towers, wires, cables, conduits, vaults, pipelines, laterals or any other similar distributing equipment for a public utility. However, where such public utility uses are proposed to be located across unplatted lands, such uses may be allowed subject to the issuance of conditional use permits in accordance with the provisions of Section [28.12(11)].
- B. Transit shelters may be permitted in any zoning district only after the location is approved by the Zoning Administrator.
- C. The regulations in this ordinance governing lot size, bulk requirements, and access to improved public streets shall not apply to any lot designed or intended for a public utility and public service use when approved by the Plan Commission.

*Telephone booths were also a ZA approval along with "bus shelters" - probably no longer needed.*

## Environmental Protection Standards

- A. All uses shall be conducted so as to prevent or substantially minimize any nuisance, hazard, or commonly recongized offensive conditions, including creation or emission of dust, gas, smoke, noise, fumes, odors, vibrations, particulate matter, chemical compounds, electrical disturbance, humidity, heat, cold, glare, or night illumination.
- B. No use shall result in the harmful discharge of any waste materials across the boundaries of the subject property or into the ground, into any sanitary or storm sewer system, into ay water body or water system, or into the atmosphere.
- C. The Zoning Administrator may require evidence of adequate controls on any potential nuisances or hazards prior to issuing a zoning or occupancy certificate.

## Telecommunication Facilities and Antennas

### (1) Intent

The purpose and intent of this section is to strike a balance between the federal interest concerning the construction, modification and siting of telecommunication towers and antennas for use in providing personal wireless services, and the interest of the City in regulating local zoning. These regulations are designed to protect and promote the public health, safety and welfare of the community and the aesthetic quality of the City. The goals of this section are to:

- A. Protect residential areas and land uses from the potential adverse impacts of towers and antennas;
- B. Minimize the total number of towers throughout the community;
- C. Encourage the joint use of new and existing tower sites as a primary siting option rather than construction of additional single-use towers;
- D. Minimize the visual impact of towers and antennas; and avoid potential damage to adjacent properties from tower failure through engineering and careful siting of tower structures.

It is also the intent of this section to provide a public forum to insure a balance between public concerns and private interests in establishing commercial telecommunication and related facilities.

### (2) Related Definitions

Specific terms used in this section are defined as follows.

- A. Antenna. Any exterior transmitting or receiving device mounted on a tower, building, or structure and used in communications that radiate or capture electromagnetic waves, digital signals, analog signals, radio frequencies (excluding radar signals), wireless telecommunications signals or other communication signals.
- B. Co-location. The provision of multiple antennas of more than one commercial wireless communication service provider or government entity on a single tower or structure.
- C. Commercial Use. A use that involves the exchange of cash, goods or services, barter, forgiveness of indebtedness, or any other remuneration in exchange for goods, services, lodging, meals, entertainment in any form, or the right to occupy space over any period of time. *[SUGGEST DELETING THIS DEFINITION]*
- D. Equipment building, shelter or cabinet. A cabinet or building used to house equipment used by telecommunication providers.
- E. Lattice Tower. A self-supporting structure, erected on the ground, which consists of metal crossed strips or bars to support antennas and related equipment.
- F. Monopole. A monopolar structure, erected on the ground to support

wireless communication antennas and connecting appurtenances.

- G. Personal Wireless Services. Commercial mobile services, unlicensed wireless services and common carrier wireless exchange services as now defined in 47 U.S.C. 332 § (7)(C), as the same may be amended from time to time.
- H. Telecommunication Facilities. Any plant or equipment used to carry wireless commercial telecommunications services by radio signal or other electromagnetic waves, including towers, antennas, equipment buildings, parking area and other accessory development.
- I. Telecommunications Tower. A mast, pole, monopole, guyed tower, lattice tower, free-standing tower, or other structure designed and primarily used to support antennas. A ground or building mounted mast greater than fifteen (15) feet tall and six (6) inches in diameter supporting one or more antennas, dishes, or arrays shall be considered a telecommunications tower.

**(3) Registration of Telecommunications Carriers and Providers**

- A. Registration and Application Requirements. All personal wireless service carriers and providers that offer or provide any telecommunications services for a fee directly to the public, either within the City or outside the corporate limits from telecommunications facilities within the City, and all Telecommunications tower owners, shall register and provide to the City, pursuant to this ordinance, on forms to be provided by the Neighborhood Preservation and Inspection Division Director and shall provide with each conditional use application the following information:
  - 1. The identity and legal status of the registrant, including any affiliates.
  - 2. The name, address and telephone number of the officer, agent or employee responsible for the accuracy of the registration statement.
  - 3. A narrative and map description of registrant's existing telecommunications facilities within the City, adjacent cities, villages and townships.
  - 4. Such other information as the Neighborhood Preservation and Inspection Division Director may reasonably require.
- B. Purpose of Registration. The purpose of registration under this ordinance is to:
  - 1. Provide the City with accurate and current information concerning personal wireless services carriers and providers and telecommunications tower owners, who offer or provide services within the City, or that own or operate telecommunication facilities within the City.
  - 2. Assist the City in enforcement of this Section.

3. Assist the City in monitoring compliance with local, state and federal laws.
- C. Enforcement. Any personal wireless services carrier or provider who offers or provides services within the City, or any telecommunications tower owner who owns or operates telecommunications facilities within the City, must register and provide the information required in subdivision (A) above within thirty (30) days of such a request by the City.
- D. Conditional Use Application Requirements. In addition to the requirements contained in subdivision (3)A. above, the conditional use application shall address the following:

1. The requirements contained in subdivisions (5), (6), (7), (8) and (9) below, including a narrative and map description of the applicant's system-wide plan describing existing and applied for facilities to serve the community.
2. A visual analysis, which may include photo montage, field mockup, or other techniques shall be prepared by or on behalf of the applicant which identifies the potential visual impacts and the design capacity of the proposed facility to the satisfaction of the Plan Commission.

Consideration shall be given to views from public areas as well as from private residences. The analysis shall assess the impacts of the proposed facility and other existing telecommunication facilities in the area, and shall identify and include all feasible mitigation measures consistent with the technological requirements of the proposed personal wireless services. All costs for the visual analysis, and applicable administrative costs, shall be borne by the applicant.

As part of the Plan Commissions continuing jurisdiction over conditional uses, each registrant shall inform the City, within sixty days, of any change in the information set forth in subdivision (3)A.

- E. Minor Alterations. Antennas affixed to an existing telecommunications tower or structure, together with the related support facilities and equipment buildings, or the replacement of a previously approved telecommunications tower and related antennas, support facilities and equipment buildings, may be authorized by issuance of a permit as a minor alteration to an existing conditional use or an existing permitted use when approved by the Director of Planning and Community and Economic Development, which are compatible with the concept approved by the City Plan Commission and/or the *[conditional use]* standards in sec. [28.12(11)(g)], of this ordinance. If the minor alteration is not approved, the applicant shall apply to the Plan Commission for approval in accordance with the conditional use standards of this ordinance.
- F. Inventory and Tracking System. The zoning administrator shall compile a list of existing telecommunications facilities within the

City's jurisdiction based upon information provided by personal wireless services providers and telecommunications tower owners. The Zoning Administrator shall maintain and update said list on a regular basis. The list shall also include the location of public facilities that may be available for co-location.

- G. A professional engineering consultant shall review each conditional use application for compliance with the requirements set out in subsections (7) and (8) below.

#### **(4) Abandonment**

If a telecommunication facility shall cease to be used for a period exceeding one year and a day, the owner or operator of said facility shall remove the facility upon the written request of the City Neighborhood Preservation and Inspection Division Director at no cost to the City within ninety (90) days of said request. Prior to the issuance of any building or zoning permits, a performance bond shall be provided to guarantee that a facility that has ceased being used for telecommunication purposes is removed. The bond amount shall be the lesser of twenty thousand dollars (\$20,000) or an amount based on a written estimate of a person qualified to remove such structures.

#### **(5) Structural Requirements**

Every telecommunication facility shall be designed and constructed so as to comply with the requirements of Secs. Comm 62.35 to 62.41, Wisconsin Administrative Code, as amended from time to time. If, upon inspection, the Neighborhood Preservation and Inspection Division Director concludes that a tower fails to comply with such codes, in effect at the time of construction, and constitutes a danger to persons or property, then upon notice being provided to the owner of the tower, the owner shall have thirty (30) days or such time as determined by the Neighborhood Preservation and Inspection Division Director to bring such tower into compliance with said codes.

Failure to bring such tower into compliance within said thirty (30) days or such time as determined by the Neighborhood Preservation and Inspection Division Director shall constitute grounds for the removal of the tower or antenna at owner's expense.

#### **(6) Basic Tower and Building Design**

All new telecommunication facilities, except exempt facilities as defined in subsection (9), below, shall be designed to blend into the surrounding environment to the greatest extent feasible. To this end all the following measures shall be implemented.

- A. Telecommunications towers shall be constructed out of metal or other nonflammable material, unless specifically permitted by the City to be otherwise.
- B. Telecommunication support facilities (i.e., equipment rooms, utilities, and equipment enclosures) shall be constructed out of nonreflective materials (visible exterior surfaces only) to all extent possible and, where possible, shall be sited below the ridge line or

designed to minimize their impact.

- C. Telecommunication equipment buildings, shelters and cabinets shall be treated to look like a building or facility typically found in the area.
- D. The City shall have the authority to require reasonable special design (materials, architectural features and color) of the telecommunication facilities where findings of particular sensitivity are made (e.g. proximity to historic or aesthetically significant structures, views and/or community features).
- E. Telecommunication facilities shall insure that sufficient anti-climbing measures have been incorporated into the facility, as needed, to reduce potential for trespass and injury.
- F. Equipment buildings shall be located, designed and screened to reduce visual impacts to the extent feasible considering the technological requirements of the proposed personal wireless services and the need to be compatible with neighboring residences and the character of the community.
- G. Antennas shall be designed to blend with its supporting structure. The color selected shall be one that in the opinion of the Plan Commission will minimize the visibility of the antennas to the greatest extent feasible

## **(7) Location**

All new telecommunication facilities shall be located so as to minimize their visibility and the number of tower sites. To this end, a good faith effort in achieving colocation shall be required of the requestor and host entity, subject to existing co-location contracts; and all of the following measures shall be implemented for telecommunication facilities in addition to meeting the conditional use standards in sec. [28.12(11)] of these ordinances:

- A. No telecommunications tower shall be installed closer than one-quarter (¼) mile from another telecommunications tower, measured from the base of the existing tower to the base of the proposed tower, unless credible evidence to a reasonable degree of certainty acceptable to the Plan Commission is submitted showing a clear need for said new tower and the infeasibility of co-locating it on an existing site. Such evidence may include but is not limited to the following:
  - 1. A demonstration that no tower in the area that the applicant's equipment must be located is of sufficient height to meet applicant's requirements and the deficiency in height cannot be remedied at a reasonable cost;
  - 2. A demonstration that the existing tower is not of sufficient strength to support applicant's equipment and the deficiency in structural strength cannot be remedied at a reasonable cost;
  - 3. A demonstration that the applicant's equipment would cause electromagnetic interference with equipment on the

existing telecommunications tower(s) within the area in which the applicant's equipment must be located, or the equipment on the existing telecommunications tower(s) would cause interference with the applicant's equipment and the interference, from whatever source, cannot be eliminated at a reasonable cost;

4. A demonstration that the fees, costs or contractual provisions required by the owner in order to co-locate on an existing communication tower are unreasonable relative to industry norms;
5. A demonstration that there are other factors that render existing communication towers unsuitable or unavailable and establishes that the public interest is best served by the placement or construction of a new telecommunications tower.

For the purposes of this requirement, exempt telecommunications facilities unavailable for co-location shall not be included in the one-quarter (¼) mile computation.

- B. No telecommunication tower shall be located on a lot in a residence district, unless said lot is greater than two (2) acres in area and the principal use is other than residential.
- C. Telecommunications towers, guy wires, appurtenant equipment and buildings shall comply with the yard and set back requirements of the zoning district in which they are located and, in addition thereto, all telecommunications towers shall be set back at least one hundred (100) feet from any property devoted to residential use or two hundred (200) feet from any residential building, whichever is less.

## **(8) Co-located and Multiple-User Facilities**

- A. Analysis. Unless an applicant is submitting an application to locate or co-locate upon an existing tower or structure, an analysis shall be prepared by or on behalf of the applicant, subject to the approval of the Plan Commission, which identifies all reasonable, technically feasible, alternative locations and/or facilities which would be useable for the proposed personal wireless services.

The intention of the alternatives analysis is to present alternative strategies which would minimize the number, size and adverse environmental impacts, including aesthetics, of facilities necessary to provide the needed services to the City and surrounding rural and urban areas. The analysis shall address the potential for co-location at an existing or a new site and the potential to locate facilities as close as possible to the intended service area. It shall also explain the rationale for selection of the proposed site in view of the relative merits of any of the feasible alternatives.

Approval of the project is subject to the Plan Commission making a finding that the proposed site results in fewer or less severe environmental impacts, including aesthetics, than any feasible alternative site. The City may require independent verification of this analysis by a qualified engineer at the applicant's expense.

Facilities which are not proposed to be co-located with another telecommunication facility shall provide a written explanation why the subject facility is not a candidate for co-location.

- B. Design for Co-Location. All new telecommunications towers shall be structurally and electrically designed to accommodate at least three (3) separate antenna arrays, unless credible evidence is presented that said construction is economically and technologically unfeasible or the Plan Commission determines that for reasons of aesthetics or to comply with the standards of sec. [28.12(11)], a telecommunications tower of such height to accommodate three (3) antenna arrays is unwarranted.

Multi-user telecommunications towers shall be designed to allow for future rearrangement of antennas and to accept antennas mounted at varying heights. Parking areas, access roads, and utility easements shall be shared by site users, at fair market rates as determined by customary industry standards, when in the determination of the Plan Commission this will minimize overall visual impact to the community.

## (9) Exempt Facilities

- A. Amateur radio towers installed, erected, maintained and/or operated in any residential zoning district, by a federally-licensed amateur radio operator, complying with the provisions contained in Chapter 17, MGO, so long as all the following conditions are met:
1. The antenna use involved is accessory to the primary use of the property which is not a telecommunication facility;
  2. In a residential zone, no more than one support structure for licensed amateur radio operator is allowed on the parcel;
  3. Sufficient anti-climbing measures have been incorporated into the facility, as needed, to reduce potential for trespass and injury.
- b. Publicly owned and operated telecommunications facilities required in the public interest to provide for and maintain a radio frequency telecommunication system, including digital, analog, wireless or electromagnetic waves, for police, fire and other municipal services.

## (10) Penalties

Any person who violates any provision of this ordinance or fails to comply with any of its requirements shall upon conviction thereof forfeit not less than ten dollars (\$10) nor more than two hundred dollars (\$200) for each violation, and in addition shall pay all costs and expenses involved in the case. Each day such violation continues shall be considered a separate offense.

*[NOTE - DIFFERS FROM GENERAL PENALTY LANGUAGE IN 28.12(13), WITH RANGE OF \$1 TO \$1,000. IS SEPARATE PROVISION NECESSARY?]*